



# LETTING THINGS SPEAK

A case study in the reconfiguring of a South  
African institutional object collection

Joanne Bloch

Thesis presented for the Degree of Doctor of Philosophy

Department of Fine Art

University of Cape Town

February 2016

The copyright of this thesis vests in the author. No quotation from it or information derived from it is to be published without full acknowledgement of the source. The thesis is to be used for private study or non-commercial research purposes only.

Published by the University of Cape Town (UCT) in terms of the non-exclusive license granted to UCT by the author.

***For Georgia***

# CONTENTS

<b>Acknowledgements</b> .....	<b>5</b>
<b>Abstract</b> .....	<b>7</b>
<b>Introduction</b> .....	<b>11</b>
A quirky collection .....	11
Boxes of things.....	13
Buried things: a second layer .....	17
Escalating curiosity.....	17
‘Thing power’ in the archive .....	19
My self in crisis.....	21
Research question.....	23
Rationale .....	23
Myself as artist – collector .....	25
Methodology .....	26
Chapter outline .....	36
<b>Chapter One: The object collection in context: a brief history of the early years of the Manuscripts and Archives Department</b> .....	<b>39</b>
‘Many innovations’ .....	39
Into the archive: ambivalent beginnings.....	40
R.F.M. Immelman, scholar – librarian .....	41
A note on value .....	46
The (partially) tainted archive.....	48
The archive in the library .....	51
The museum in the library .....	54
Returning to the boxes.....	56
<b>Chapter Two: Things and their actancy: applying a range of theoretical understandings of things to the Manuscripts and Archives object collection</b> .....	<b>57</b>
The potency of things .....	57

‘Things’ versus ‘objects’ .....	59
The strangeness of things .....	59
Material markers .....	61
The taint of the past.....	61
The things’ affordances.....	62
The things’ medium and its effects .....	63
Listening to things’ stories .....	65
<i>Slantways</i> as an agglomeration of assemblages .....	68
Contextualising <i>Slantways</i> .....	69
<b>Chapter Three: An overview of artists working with the archive .....</b>	<b>70</b>
The archival turn .....	70
The critical archive .....	72
The curation of institutional collections .....	79
The future-entailing archive.....	82
Points of intersection .....	82
<b>Chapter Four: <i>Slantways</i>, September 2014 .....</b>	<b>84</b>
A set of creative strategies.....	85
Understanding ‘ <i>Slantways</i> ’ as a set of assemblages .....	87
Referencing trouble: choosing to exhibit in the Centre for African Studies (CAS) Gallery .....	88
The artworks .....	91
<b>Finding Aid: The archive partially seen.....</b>	<b>91</b>
<b>Hoard .....</b>	<b>96</b>
<b>Entanglement .....</b>	<b>121</b>
Three performative pictures .....	131
<b>Homage to Mr Immelman .....</b>	<b>132</b>
<b>Troublesome Ancestors I and II.....</b>	<b>134</b>
<b>The Rhodes ‘undeath’ masks .....</b>	<b>140</b>
<b>Musa Askari .....</b>	<b>153</b>
<b>Sense of Place I and II.....</b>	<b>160</b>

Translation I: The Queen’s Speech .....	171
Translation II: From ‘The New Game of HUMAN LIFE’ .....	177
Translation III: Voyage .....	183
Satellite Exhibit .....	188
<b>Conclusions .....</b>	<b>192</b>
i. The disabled body as actant .....	193
ii. Working with a marginalised object collection to expose the limits of taxonomy .....	194
iii. Understanding university collections differently.....	195
iv. Using art to trouble the university archive .....	196
v. Actancy and things in the archive: the thing called Rhodes .....	204
vi. An archive that speaks to the present.....	208
<b>Works Cited .....</b>	<b>211</b>
<b>APPENDIX 1: A brief art autobiography.....</b>	<b>232</b>
<b>APPENDIX 2: Hoard – list of artefacts .....</b>	<b>237</b>
CABINET 1 .....	237
CABINET 2 .....	238
CABINET 3 .....	239
CABINET 4 .....	240



# ACKNOWLEDGEMENTS

I am deeply indebted to my supervisors, Pippa Skotnes and Carolyn Hamilton, not only for their rigorous critical and considered creative input, but also for their generous help with funding, and for their unwavering moral support.

I would also like to thank Penny Siopis for her willingness to listen and to share her knowledge, imagination and experience, to the great benefit of this project.

Heartfelt thanks to Carole Bloch and George Ellis for their fantastic generosity and quiet kindness.

Thanks are due to Lesley Hart, Renate Meyer, Clive Kirkwood, Isaac Ntabankulu and Tanya Barben for their help in the archive. I am also grateful to Vida Allen, Mary Simons, Paul Walters, Brenda Schmahmann, Nomusa Makhubu and Brian Watermeyer for their assistance in my research.

Thank you too to my many colleagues from the APC, whose dedicated intellectual engagement made for an inspiring learning experience. Their comments and discussion over the past five years not only helped me with this project, but also greatly enhanced my broader understanding.

Many thanks to my readers, including Vaun Cornell, Sean Archer, Mica LaVita, Miles Collins, Michael Nixon, Alex Dodd, Brenton Maart, Sue Isserow, Benji Timm, Judy Tobler and Chas Unwin.

Thanks to Georgia Humphrey for her speedy typing, Kelly Woollatt for her meticulous work on my bibliography and referencing, and Mandy Darling for her great design and layout.

Thanks to Special Collections, UCT, Andrew Juries. Mike Hall and Je'nine May for the photographs reproduced in this thesis.

I am indebted to numerous creative collaborators, helpers and friends, including Lucia Banda, Chris Emery, Andrew Juries, Ivan Kiley, Richard Kilpert, Manesi Kekana, Mark Lewis, Vekhe Kruger, Hedley Twidle, James Webb and Dana Weiner. In particular, my most heartfelt thanks go to Erica de Greef, who has helped me enormously in ways far too many to mention.

Finally, my sincere thanks to the National Research Foundation and the University of Cape Town for their financial support, without which I could not have pursued this project.



# ABSTRACT

In this thesis I examine the University of Cape Town (UCT) Manuscripts and Archives Department object collection, providing insights into the origins of the collection and its status within the archive. Central to the project was my application of a set of creative and affective strategies as a response to the collection, that culminated in a body of artwork entitled *Slantways*, shown at the Centre for African Studies (CAS) Gallery at UCT in 2014.

The collection of about 200 slightly shabby, mismatched artefacts was assembled by R.F.M. Immelman, University Librarian from 1940 until 1970, who welcomed donations of any material he felt would be of value to future scholars. Since subsequent custodians have accorded these things, with their taint of South Africa's colonial past, rather less status, for many years they held an anomalous position within the archive, devalued and marginalised, yet still well-cared for.

The thesis explores the ways in which an interlinked series of oblique or slantways conceptual and methodological strategies can unsettle conventional understandings of these archival things, the history with which they are associated, and the archive that houses them. I show how such an unsettling facilitates a complex and subtle range of understandings of the artefacts themselves, and reveals the constructed and contingent nature of the archive, as well as its biases, lacunae and limitations in ways that conventional approaches focusing on its evidentiary function allow to remain hidden.

This set of slantways strategies includes the use of a cross-medial creative approach, and my focus on an atypical, marginalised and taxonomy-free collection. Also important is the incorporation of my visual impairment as a vital influence on my artwork, leading to an emphasis both on unusual forms of seeing and on the senses of smell, touch and hearing. Furthermore, my choice to follow a resolutely thing-centred approach led me to engage very closely with the artefacts' materiality, and subsequently with their actancy as archival things, which in turn influenced my conceptual and creative choices.

Specifically, via these interlinked strategies, my artwork (and the approach that was integral to it) underscored the sometimes paradoxical attributions of value, the limitations imposed by conventional taxonomies, the hidden affective and sensorial dimensions, the fluidity of meanings over time and the biases

and omissions prevailing in the archive. Further, it challenged my viewers to engage with our collective past more imaginatively and more ethically. Via a small intervention in the archive itself, I highlighted its constructed nature and questioned its claims to be an all-encompassing and neutral mainstay of the control and production of knowledge within the university.

The centrepiece of my exhibition, *Hoard*, presents a faux gold imposter version of the object collection, complete with additions from the renowned Mapungubwe collection and from my own personal archive. In 2014, I offered to sell this work to the UCT Works of Art Committee, in the hope that it would be displayed near to the archive that the body of work it belongs to seeks to trouble and explore. Whether this sale is concluded or not, my disruption of the university archive via this body of work and my effort to instantiate this disruption on a more permanent basis in the university are now on record.

Given the current strident calls for transformation at UCT, I contend that similar creative interventions could potentially play a valuable part in opening up the university archive to the wide-ranging scrutiny required as part of the university's successful transition to a more equitable de-colonial institution.



**Note on presentation**

*In keeping with the conceptual choices I adopted for the presentation of my exhibition 'Slantways', design choices that include the use of a large font and generous spacing have been adopted both in this written component of my PhD project and in the exhibition catalogue. This choice references my experience of visual impairment and the challenges it presents in terms of accessibility, and is intended to bring these issues to the reader's attention.*

**Note on terminology**

*In accordance with the approach provided by thing theorist Bill Brown (2004), for the purposes of this work I have chosen as far as possible to avoid the term 'object' in favour of the term 'thing'. For variety and ease of reading, I also sometimes use the term 'artefact'. However, I do use the term 'object' where this is part of the terminology of the UCT Manuscripts and Archives Department, e.g. the 'Museum Objects finding aid' and the 'object collection'.*

# INTRODUCTION

## A quirky collection

I first encountered the University of Cape Town's Manuscripts and Archives Department object collection in early 2011. I had just embarked on a PhD inclusive of a practical component, attached to the Archive and Curatorship (ARC) project<sup>1</sup> under the auspices of the Centre for Curating the Archive (CCA) at Michaelis, in conjunction with the multidisciplinary Archive and Public Culture Research Initiative (APC),<sup>2</sup> based in the Anthropology Department at UCT.

At this time, I had only a modest beginner's knowledge of university collections and their characteristics. I had, however, gathered that, like most universities, UCT is home to numerous specialised collections, which are seen as belonging and relating to a particular area of study, to which they add value by means of the empirical evidence they provide for teaching purposes and research.<sup>3</sup> I also knew that one of the distinguishing features of such collections is their strict assignment to the discrete disciplinary silos to which their material is understood to relate.

It was immediately clear that the Manuscripts and Archives object collection deviated absolutely from the format I had begun to expect. Made up of an eclectic and intriguingly incoherent assortment of largely colonial- (but in a few cases apartheid-) era things, with no discernible overarching taxonomical system at work, and no relationship to any particular discipline, this rather neglected collection was clearly an animal of an altogether different stripe.

Information on the collection was scant, though Lesley Hart, the then manager of the department,<sup>4</sup> informed me that the things had been set aside as the basis for a museum that never came to fruition in the late 1970s and early 1980s (Lesley Hart, personal communication, 10 April 2011). Most, but not all of the artefacts were listed on a spreadsheet finding aid entitled

---

1 A UCT strategic focus, designed to highlight existing and promote new archival curatorial initiatives utilizing visual methodologies within the university (ARC, n.d.).

2 See UCT, 2015a. Archive & Public Culture.

3 South African examples are the Wits Museum of Ethnology, the Mapungubwe Collection at the University of Pretoria, and the Bolus Herbarium and the Kirby Collection at UCT.

4 Hart managed the Manuscripts and Archives Department from 1995 until her retirement in 2013.

'Museum Objects', which Hart had transcribed from a set of handwritten notes dating back to sometime in the 1960s. This term, 'museum objects', seems to refer, not to the unrealised intention to establish a museum, but rather to the way staff members named the things in the archive in the early days of the department (Gerald Quinn, interview, 12 December 2011).<sup>5</sup> Some of the things in the finding aid had donation numbers, but others did not.

Hart also explained that most of the artefacts were associated with R.F.M. Immelman, the UCT Chief Librarian, who retired in 1970 after working at the university for 30 years. During his three decades at UCT, his avowed major concern was to build the library into an outstanding institution; and to this end, he took it upon himself to adopt a vigorous, ongoing practice of soliciting donations from likely sources (Phillips, 1993:121). Via this strategy, he acquired, along with many books, numerous artefacts.

The division between private and institutional collecting is not always clear. These two areas of activity are, in fact, often intertwined both in direct and in more subtle ways (Macdonald, 2006:98). In many instances, private collections ultimately developed into institutional collections, for example, Sigmund Freud's collection of antiquities, which is now at the heart of the Freud Museum in London. A good local example is the Killie Campbell collection associated with the University of KwaZulu-Natal.

Immelman's case is slightly different. Although he was collecting specifically for the UCT library, interviews support the view that his sensibility was not unlike that of an individual collector, whose practice of acquiring objects can be seen as the expression of a

... grand attempt to overcome the wholly irrational character of the object's mere presence at hand through its integration into a new, expressly devised historical system: the collection ... [with] ... every single thing in this system ... [becoming] ... an encyclopaedia of all knowledge of the epoch, the landscape, the industry and the owner from which it comes (Benjamin, 2002:204).

In other words, Immelman seems to have been engaging with his personal desire to collect at the interface between private and public collection, with the idea from the outset that his collection would add value to the institution.

---

5 Quinn served as a librarian at UCT from 1960–1973.

Though he directed his passion for collecting most particularly at the acquisition of books, his enthusiasm extended to anything that he felt would add value to the UCT library, including the things discussed here. He was convinced that at some unspecified future time, they would be of educational value to students and researchers at UCT (Jeanne Cope, interview, 23 April 2011 and Gerald Quinn, interview, 12 December 2011).

It could be argued that, in relation to these artefacts, the lack of any overarching taxonomical validation seems to refute the argument that Immelman was building a collection, as opposed to randomly accumulating interesting artefacts as they happened to come his way. However, the very fact that he was collecting for an institutional library, which presumably he understood as having the capacity to outlast his own human lifespan, supports the notion that his acceptance of artefacts into the archive was an attempt to salvage historical material from the inevitability of decay, and preserve it for the interest of future generations — the ‘practical memory’ alluded to by Walter Benjamin and Theodor Adorno in their theorizing of collecting (Crimp, 1989, cited in Bounia, 2004:14).<sup>6</sup>

## **Boxes of things**

The object collection consists of roughly 200 artefacts. At the time I first encountered it, most of these things were packed haphazardly into five cardboard boxes, though a small selection that was considered particularly valuable was kept in a safe. It is no exaggeration to say that these often shabby and battered artefacts, if they were even remembered, were considered in the department as no more than rather uninteresting remnants of a long past era. Arguably, they were even disavowed: Immelman’s daughter, Jeanne Cope, states firmly that subsequent departmental heads did not value the artefacts that her father had collected in the same way that he had, and did not afford them the same care (Jeanne Cope, interview, 23 April 2011). In a different

---

6 In this effort, Immelman shared the instincts if not the focus and resources of the Durban-based Campbell family, who during roughly the same period were motivated by a ‘strong sense of duty’ and a concern that urban Africans were losing their cultural traditions, to collect images, oral testimonies and artefacts relating to indigenous South African material culture (Dominy in Knell, 1999:139). This collection was donated to the University of Natal in the 1950s.



Chip of wood associated with David Livingstone, pink silk tie, Rhodes 'deathmask', fragment of wood from the 'Fram', walking stick presented to Dr C.H. van Zyl by the Khedive of Egypt, travelling microscope, miniature Bible, set of postcards commemorating Rhodes' birth, silver inkstand, Victorian spelling game, three wax seals and Victorian game 'Frogs and Toads'.

vein, but with similar effects in terms of her attitude towards the relevance of the object collection, Leonie Twentyman-Jones, who headed the Manuscripts and Archives Department from 1975–1995, referred explicitly to a change in emphasis during that time in accordance with the politics of the day. At this time, most of the material that was collected related to the mass democratic movement and anti-apartheid struggle in the Cape, rather than to Immelman's broad conception of history.<sup>7</sup> In this context, the value of the colonial-era artefacts could only diminish. Finally, by the time then manager Lesley Hart first showed me the artefacts, she adopted a neutral tone towards most of them, but told me that she did not consider them as suitable material for a PhD project.

Apart from an assortment of items directly associated with UCT itself or its predecessor, the South African College,<sup>8</sup> such as badges, medals and a university crest, the artefacts fit as awkwardly with each other as they fit into the archive. Some of them could be considered as colonial-era curiosities. A prime example is a little block of wood, carved from the tree in Kuruman under which the early explorer David Livingstone proposed in 1844 to Mary Moffatt, daughter of the Scottish Congregationalist missionary Robert Moffatt. Another, also a rough oblong of wood, that has the words '*Polarskibet Fram*' burnt into it, is described in the finding aid as having come from the ship used by Norwegian explorer Fridtjof Nansen in his 1893–1896 expedition to the geographical North Pole. Others speak more directly of colonial rule in South Africa, for example, the plaster of Paris mask described as the deathmask of Cecil John Rhodes, and a gold-topped walking stick presented in 1902 by the Khedive of Egypt to Dr C.H. Van Zyl, father of Dr G.B. Van Zyl, Governor General of the Union of South Africa from 1945 to 1950. Certain other objects were clearly commercially produced as collectible curiosities, for example, two miniature Bibles, and a set of miniature postcards produced in the then Rhodesia to commemorate the centenary of Rhodes' birth in 1853. Some were obviously considered valuable or interesting by association with noteworthy or celebrated historical figures, such as a moonstone bracelet and amethyst brooch thought once to have been

---

7 She also noted that her policy was only to collect artefacts that were in some way related to the history of the university itself, though some artefacts did enter the archive attached to a manuscript or other textual collections (Twentyman-Jones, e-mail correspondence, 7 June 2011).

8 Founded in 1829 as a boys' school. The university itself was established as a separate institution between 1880 and 1890 (University of Cape Town, 2015b).

owned by South African author, Olive Schreiner,<sup>9</sup> and a travelling microscope described in the finding aid as having been used on the voyage of H.M.S. Beagle (1831–1836).<sup>10</sup> Some could straddle several of these categories. Yet others for example, articles of clothing and accessories, several Victorian board games, wax seals and various silver artefacts, relate to the material culture of the colonial epoch, and can be imagined as fitting comfortably into the vitrines of an old-fashioned cultural history museum display.

The existence within the archive of this first category of artefacts, the ‘museum objects’ interested me greatly; and I asked myself many questions relating to the nature and value of such an object collection within a university archive — particularly when further research revealed that, though the individual circumstances relating to their establishment might be different, similar collections are not uncommon in other local and international university libraries.<sup>11</sup>

The collection also aroused my curiosity in relation to the processes of custodianship and the epistemological divisions at play in the placement of this collection, once envisaged as the basis of a museum, within an archive that is itself located within a library. Libraries, museums and archives house different artefacts; have different functions and operate in different ways.<sup>12</sup> However, since libraries, along with museums, can be considered as ‘... seek[ing] to represent experience within a mode of control and confinement’ (Stewart, 1998:161), and archives, too, are understood to be technologies of control (Stoler, 2009:31-35), the existence of these forgotten old things in the limbo of the dark, air-conditioned recesses of the archive seemed to speak interestingly of possible epistemological uncertainties on the part of the library staff with regard to that very process of organisation and control (Stoler, 2009:3).

---

9 This provenance is uncertain — according to the finding aid, ‘Miss Eberhard thinks that these belonged to Olive Schreiner. Were they perhaps given by U Scott?’

10 Though here too, my own research casts doubt on this provenance — see Chapter Four.

11 The object collection housed in the Cory Library at Rhodes University is a good local example. Like the ‘museum objects’ collection, the artefacts making up this collection are not attached to any fonds, but are simply stored in the library basement. They include, amongst many other things, a stereoscope viewer, a wheelchair, a pair of spectacles, an embroidered cloth bearing Rhodes’s signature, several reef samples, a mantelpiece cloth and the teapot used during the sinking of no.1 shaft at Vogelsruisbult Mine. (Liz De Wet, interview, 18 May 2012).

12 However, these divisions and distinctions do seem to have blurred in the case of the Manuscripts and Archives Department. See Chapter One for a discussion of this issue.

## **Buried things: a second layer**

For me these issues merited investigation; but the chance emergence of a few artefacts completely separate from the 'museum collection', signalling the existence of a second, even more deeply hidden layer of things within the archive, served to increase the complexity of the study. These 'buried' artefacts are quite literally an unknown quantity. Because they entered the archive tied to donations or bequests of personal and organisational papers, records and other ephemera, they will, in keeping with accepted archival practice, remain tied to these collections. This means that their very existence is only revealed on close inspection of the finding aid relating to their particular collection. Neither the total number of artefacts within the archive nor even what form most of them take is currently known to the librarians working with the collections.

There are, however, always a few exceptions — items that at different times are recalled by particular librarians as elements of collections they have recently worked with, or things known to the manager of Manuscripts and Archives through her research into the collections. These artefacts are extremely diverse. They include a worn cardboard model of the human brain that was used by amateur phrenologist J.G. Davidson in the 1950s, a medicine chest complete with ancient medicines used by dentist Dr Walter Floyd on a hunting trip to the then Northern Rhodesia in 1913, Tibetan Buddhist prayers painted onto fabric, a book made from bark, voting and ceremonial equipment associated with the secret society 'The Sons of England', anthropologist Monica Wilson's dental X-rays from 1937, swords dating back to the Peninsular Wars (1807–1814) and four hairbrushes and a hand mirror once owned by struggle veteran and trade unionist, Ray Alexander.

## **Escalating curiosity**

My realisation of the presence of these 'buried' things, which may represent only a fraction of those housed in the archive, provoked additional curiosity, and inspired a series of new, interlinked questions. Their existence as individual artefacts — as opposed to those assembled and cared for as a collection amongst other collections (albeit one that has never seen its potential for



Some of the things attached to particular archival collections within the Manuscripts and Archives Department – medicine chest, phrenology kit, cloth addressed by Olive Schreiner, Ray Alexander’s hairbrushes, Monica Wilson’s dental X- rays, book made from bark and swords dating back to the Peninsular Wars.

permanent display realised) — threw the presence of artefacts within the archive into even starker relief. It seemed so curious that these things, with their potentially rich (though when I first encountered them largely incoherent or mute) layers of historical associations, could be fated to lie forgotten in the stockrooms, kept so utterly removed from the humans who might use them, touch them, or simply look at them.

In keeping with my own history as an artist-collector obsessively interested in things and their currency, I found myself increasingly fascinated by the artefacts' materiality as things marooned in an archive, their past entanglements with particular people, their accession into the archive and the paradox of their continued presence there, despite their current apparent neglect and dormancy. They aroused in me the desire to acknowledge them and interact with them, to use my project as a space in which to allow what Jane Bennett names as their 'thing power' to come to the fore — '... the curious ability of inanimate things to animate, to act, to produce effects dramatic and subtle' (Bennett, 2010:6), and mobilise my artworks in the service of its expression.

### **'Thing power' in the archive**

For Bennett, this 'thing power' provides a way of understanding things as '... quasi agents or forces with trajectories, propensities, or tendencies of their own' (Bennett, 2010:iii). Following Latour, Bennett names this quality as actancy — as she puts it, 'the it as actant' (Bennett, 2010:3).

My own understanding of this concept as it applies specifically to these archival artefacts has many inter-related elements, all of which had some conceptual bearing on the artwork I produced for the practical component of the project. In the chapters that follow,<sup>13</sup> I both explore these aspects of the things' agentic capacities more fully, as well as describe ways in which they played out in the creative processes I undertook. Here, I will simply give brief outlines of the aspects of 'thing power' that concern me most, and that provide the conceptual underpinnings for the creative process as well as the written component in this project.

---

13 In particular, in Chapters Two and Four.

To begin with, I am interested in the question of how to understand the inscription or embedding in these archival things of particular, unique experiences — the experiences that in total can loosely be understood as making up their life stories. In Chapter Two, I discuss the work of a selection of the theorists who have concerned themselves with this issue over the past 10 or 15 years, most of them under the rubric of ‘thing theory’, and relate their conceptual insights to my own work for my PhD project. In this regard, I found the insights of Bill Brown and especially Jane Bennett very helpful.

This first question leads inevitably to an associated second one of how to access these ‘thing life stories’. For the purposes of this project, again influenced by the writing of theorists concerning themselves with the life of things, in particular Lorraine Daston, I employed what I understood as a listening or interviewing technique as a means to ascertain how the things spoke to me.<sup>14</sup> Sometimes this process involved a close engagement with previously dominant or well-known narratives or archival meta-data associated with a particular thing.<sup>15</sup> It also, however, sometimes implied deciding to ignore such information in favour of other potentially contradictory, possibly hidden information revealed by my engagement with the things.

A third, and for me, integral feature of ‘thing power’ or the things’ actancy relates to two inter-connected aspects of their materiality. Here I am referring firstly to their sometimes obvious, sometimes more subtle, discernible material attributes, all of which had particular effects on me as an artist-researcher. These include their dishevelled and slightly decrepit quality, in some cases their decidedly unsavoury, tainted nature, in the case of the ‘deathmask’ its rather sinister quality, and so on.

The other aspect to the things’ materiality and the agency it implies is the medium or media from which they took shape or were made. In the case of the object collection, there are multiple materialities at play, ranging from wood to marble, from silk to plaster of Paris, from brass to plastic and from glass to calico. In Chapter Two, as well as considering other salient aspects of the things’ materiality in more detail, I will explore how these differing materialities

---

14 See Methodology section below, as well as Chapter Two.

15 For example, the idea, recorded in the finding aid that the ‘deathmask’ is a deathmask, and Mary Brown’s memoir of Olive Schreiner, in which she discusses her association of the cloth addressed by Olive Schreiner with the smell of wood smoke and longing for the Karoo.

directly affected me as an artist producing artwork in response to the artefacts. In Chapter Four I discuss some of the choices I made in my creative responses to and representations of these original materialities, using another set of materials — materials which in all cases were different from those of the original artefacts.

A further focus on ‘thing power’ in this work concerns the artefacts’ potential to reveal more than their own stories. In several of the artworks described in Chapter Four, I sought to expose different ways in which their continuing lives as things displaced from their previous milieus and re-contextualised as a collection within the archive, unsettled conventional notions about that archive, its policies and modus operandi. One such challenge to a taken-for-granted order concerns the manner in which a collection with no taxonomy, such as the object collection, contrasts with the rigid taxonomies usually imposed in the archive, so that it reveals the artificiality of these methods of ordering and control. Another is the manner in which these things’ inclusion in the archive points to those innumerable other artefacts that, due to the oppressive racial politics of the day, reproduced to some degree in the hierarchy pertaining within the archive, were not accorded the same privilege. In this way, by carefully examining what is present in the archive, it becomes possible to ascertain its limitations and lacunae.

## **My self in crisis**

By July 2011, six months into this project, I was beginning to grapple with these and related aspects of the collection that I felt I needed to explore as a precursor to producing the practical component of the project. Suddenly, though I was forced to deal with an entirely unforeseen eventuality, the onset of severe and irreversible visual impairment.

This, to an artist obsessed from her earliest days with all things visual, was a shattering blow, and cast doubt on my ability to proceed with my PhD. However, after some intense reflection, I decided to continue the project by whatever means possible.

One of the many effects of this unfolding experience was that, without warning, my ability to engage with and respond creatively to the material I was working with was seriously compromised — quite simply, I could no longer see

it well. Another was that my certitude in terms of *how* to make art, in other words, my capacity as an artist, was now in question. For both of these reasons, I felt it necessary to attempt a process of re-orientation to the archive, to the project and to the process of art-making, so as to mitigate these difficulties in some way or ways.

Sara Ahmed, in laying the ground for her proposal of a queer phenomenology, asserts that

... orientations involve different ways of registering the proximity of objects and others. Orientations shape not only how we inhabit space, but how we apprehend this world of shared inhabitation, as well as “who” or “what” we direct our energy and attention toward (Ahmed, 2006:3). Re-orientation, then, is a process that entails “... the disorientation of encountering the world differently ...” (Ahmed, 2006:20).

Associated with this process of disorientation as an imagined first step towards re-orientation is a range of losses, the most obvious being the loss of familiarity — the loss of ‘... what is, as it were, given, and which in being given “gives” the body the capacity to be orientated in this way or in that’ (Ahmed, 2006:8). In terms of the prevailing discourses of disability, the subject of loss is extremely complex. Brian Watermeyer points out the flaws inherent in the predominant psychological stepped ‘grief model’ approach to disability.<sup>16</sup> However, he also takes issue with the social approach developed within a disability studies framework, which in reaction to the dominant ‘... pre-existing, highly elaborated stereotype of tragedy’ (Watermeyer, 2013:205) proposed by the grief model, absolutely denies that loss is an issue to people experiencing disability.<sup>17</sup>

By eschewing both of these dialectically linked extremes, Watermeyer argues for a nuanced middle ground:

Rather than denying loss, empowerment involves its deliberate and thoughtful

---

16 This model is not only inaccurate — many studies have shown that people deal with the onset of disability in unique ways that do not follow the stages set out for bereavement, but also only acknowledges the loss of impairment, without recognising the losses due to the discrimination that very often accompanies it. See chapter 9 (Watermeyer, 2013:204-212).

17 For Watermeyer, the central issue here is that ‘The discourse of loss functions culturally as a means of mastery over disability’s frightening unknowns (Watermeyer, 2009). At the heart of the observer’s control is the illusion that what has been lost can be clearly seen from the outside ... Loss is in all, and ... the disabled body is a lightning rod for split-off, painful parts of the self’ (Watermeyer, 2013:205).

claiming (Watermeyer, 2009) ... The enforced attachment or dissociation of loss from disability is rejected. Instead, loss is decolonised and welcomed back, claimed as precious and described in one's own words. Through this sort of reclamation, disabled subjectivity assumes its rightful place in the continuous stream of the human condition ... (Watermeyer, 2013:211).

In following this approach, it is important for me to acknowledge that the loss of familiar ground in terms of engagement and access has amounted to a painful falling away of much that is irreplaceable. However, without wishing to deny or hide the multiple challenges that disability presents, after some reflection, I realised that the lack of certainty/security resulting from this loss of the familiar ways of seeing and knowing did present a certain opportunity when it came to my PhD project: the onset of impairment (sometimes even literally) pushes one to the margins, and existing in this different place implies the adoption of a different perspective or set of perspectives, a different line or lines of sight. This re-alignment to an oblique angle of approach gelled with many other aspects of the project that were intrinsically indirect or oblique (See Methodology section below). I will consider the slantways creative approach it inspired in more detail in the Methodology section below, as well as in the descriptions of the artworks I produced in Chapter Four. In addition, it is a vital component of the research question that lies at the heart of this project.

## **Research question**

In what ways might my use of a set of oblique strategies to respond to an archival object collection enable a disruption of conventional views of the artefacts making up the collection, the history that the collection relates to and the archive in which it is housed, in the interests of promoting a more complex understanding of the artefacts, and of revealing aspects of the archive that this conventional approach allows to remain concealed?

## **Rationale**

My choice was to work with a marginalised and atypical object collection, at odds with the collecting and taxonomical conventions governing both the

archive as well as the various discipline-based collections at UCT. In this regard, I was motivated by the idea that an encounter unmediated by taxonomy would help to reveal less obvious or even entirely different aspects of the archival things' stories. However, I was also motivated by a desire to test out the broader proposition that, precisely *because* of the object collection's incongruity, enabling its activation has the capacity to reveal much that is taken for granted, and thus largely invisible, about the archive upon which knowledge production at the university is based, most obviously, but not confined to, the potentially limited understandings imposed by rigid taxonomies.

In terms of my adoption of a creative approach to work with the archive, which is usually associated with text-based methods of research, I was motivated by the idea that using art in this context can also reveal the archive in different ways, potentially allowing for a different, more complex set of understandings to emerge. In this regard, it is noteworthy that this thesis was written in 2015, a year in which strident calls for the decolonization of education have been heard throughout South African tertiary institutions, not least at UCT. These calls incorporate a critique of the '... Eurocentric canon that attributes truth only to the Western way of knowledge production ... [and] ... disregards other epistemic traditions' (Mbembe, 2015:9). Mbembe goes on to emphasise that

Western epistemic traditions are traditions that claim detachment of the known from the knower. They rest on a division between mind and world, or between reason and nature as an ontological *a priori*. They are traditions in which the knowing subject is enclosed in itself and peeks out at a world of objects and produces supposedly objective knowledge of those objects. The knowing subject is thus able, we are told, to know the world without being part of that world and he or she is by all accounts able to produce knowledge that is supposed to be universal and independent of context (Mbembe, 2015:9).

In the light of this critical assessment, my exploration of how creative methods can unsettle the archive and reveal archival artefacts in more multifaceted ways merits consideration: arguably the use of similar counter-hegemonic forms of research may enable an expanded sense of knowledge production, incorporating ways of understanding not usually engaged with in conventional, evidentiary archival research. For me, the fact that very similar collections

exist in the archives of various other South African universities, including the University of the Witwatersrand, Rhodes University, the Nelson Mandela Metropolitan University and the University of KwaZulu-Natal, give this question a broader significance, as these archives too, might be revealed in new ways in response to creative interventions.

## **Myself as artist – collector**

Since it goes without saying that art very seldom emerges in a vacuum, the approaches used for my creative processes were informed by my engagement with the work of contemporary artists who use individual artefacts, and/or personal, museum and archival collections in their practice (see Chapter Three). In addition I gained many insights from my interactions with my fellow students at the CCA, as well as my immersion in the research environment of the APC, which across many disciplines interrogates the multiple manifestations of the archive.

The strategies I made use of also shared some common characteristics with my art production prior to this project, though these were subtle rather than immediately obvious associations. Prior to 2011, my art production was largely based on the processes of collecting and the displaying of the things I collected. More specifically, my work had its genesis in ongoing collections of small, throwaway artefacts gleaned from lucky packets, Christmas crackers, egg machines and flea markets over many years. In the subsequent work, the joint processes of classification and reconfiguration, with their implied promise of transformation, had played a central role.<sup>18</sup>

While these strategies for making and display did not feature particularly in most of the processes I ultimately chose to employ in making the artwork for the creative component of this project in 2014, they provided important groundwork. In reconfiguring my collected pompoms, plastic babies, religious medallions, whistles, charms, fragments of costume jewellery and countless other tatty bits and pieces, I had experienced an intimate connection with them via their materiality and their narratives, both known and imagined. This stood me in good stead for the processes I employed in becoming acquainted with

---

18 See Appendix 1 for a discussion of my artwork prior to my PhD.

the artefacts from the object collection, as well as in the production of many of the artworks.

Another consequence of this creative background was a certain sympathy with Immelman. Though, had we met, it seems likely that we would have had little in common in terms of disposition as well as cultural and political leanings, in one way at least I felt a degree of kinship with him — like me, he was a collector and an individual who treasured material things.

## Methodology

### *i. Linked processes*

As a means to develop a set of creative responses sufficiently comprehensive to acknowledge the object collection both qua collection and to engage more closely with it as a set of assembled but idiosyncratic and varied artefacts, I adopted a dual approach to my production. Each of these dual processes was also then divided into two interlinked steps.<sup>19</sup>

To allow altered and diverse meanings to accrue around the collection as a whole, and to speak of value in ways that opened up the possibility of broader reflection on archival practices and assumptions, as a first step I researched the collection, the department and Immelman's role in both, by studying the finding aids, conducting interviews with Lesley Hart and previous library staff members and becoming as familiar as possible with as many of the things in the archive as I could. Subsequently, as a second step, I undertook the creation of my own 'imposter collection' — the work *Hoard*, that later formed the centrepiece of my exhibition, *Slantways*, held at the CAS Gallery in September 2014 (see Chapter Four).

In terms of which artefacts I chose ultimately to work with individually, I was guided both by my own instinctive responses to the things' biographies, as well as by practical constraints.<sup>20</sup> The first step in facilitating the emergence

---

19 This holds true for everything I produced apart from one artwork, *Finding Aid: the archive partially seen*, which considers my visual impairment and its effects for the project. On one level, this artwork has a framing role for the exhibition as a whole.

20 For example, Lesley Hart's understandable concern for items considered to be more valuable in monetary terms meant that these items were kept in a safe and were less easily available to me.

of the artefacts' stories as individual things entailed a close exploration of a selection of them, using the cultural biographical approach specifically as it used by Carolyn Hamilton to consider things in an archival context (See below). For this process, I began with what I understand as an interviewing process. This is discussed below in greater detail in relation to my oblique or slantways approach to the project. The second step in this part of the work consisted of the production of the nine artworks relating to particular individual artefacts, as well as *Finding Aid: the archive partially seen*, a work that dealt with my visual impairment and the many assistive devices that enabled my process.

In producing both *Hoard* as well as the artworks referred to above, using Bennett's conception of assemblages and their actancy, I came to understand my own role as that of a participant or agent in such an assemblage, constituted by the things from the object collection, the assistive devices and artefacts that gave me the ability to continue working despite my impairment, the many human actants involved, the production process itself and finally the artworks, all working together to produce my exhibition in 2014. I discuss this approach in Chapter Four.

## **ii. Working slantways**

*Slantways: in a slanting or oblique direction* ("Slantways, adj.", 2015).

*Slantways: Adv. 1. At a slant; moving or directed in a slantwise position or direction* ("Slantways, adv.", 2011).

The title of my exhibition, *Slantways*, expresses the primary critical concept informing this study, which I understand as operating in multiple interlinked ways in terms of my intentions, my research as well as my creative process and exhibition.

With hindsight, the invitation to an oblique approach might be said to have come with the territory. The joint affiliation to the Centre for Curating the Archive and the broadly interdisciplinary Archive and Public Culture Research Initiative from the outset represented an academic positioning outside of the clear-cut vertical silos of disciplinarity. Instead, this programme made it possible for me to enable an interaction between two somewhat different

epistemological contexts: the domain of my own art practice, and the very differently defined, contained and constrained space of the university archive, one of the mainstays of academic research.<sup>21</sup>

From this very particular and fairly unusual starting point, I took my first positively oblique step when I made the decision to work with an a-typical collection within a university context, where, as discussed above, most university collections are understood to relate to discrete disciplinary silos.

Secondly, my approach in this study is slantways in that I am consciously engaging with the archive via its object collection.<sup>22</sup> Value in an archive is almost always conceived of as residing primarily within its text-based records, manuscripts and photographic resources.<sup>23</sup> Accordingly, in most instances, such material is privileged over the artefacts that might also be held there, which are often regarded by their custodians as somewhat anomalous ‘dust collectors’, as one university librarian (who shall remain anonymous) described them. In instances where archivists do choose to draw attention to the artefacts in their collections, usually via some form of display, curiosity value is usually highlighted, as in the *Weird and Wonderfuls* exhibition held by the Cullen Library at Wits in 2011.<sup>24</sup> The tone adopted in the publicity blurb for this exhibition is revealing in this regard: the exhibition is described as ‘... giving a fascinating insight into the truly weird, wonderful, unusual and extraordinary archival treasures in the care and custody of Wits’ Historical Papers Research Archive.’ In other words, it is the curiosity value of these artefacts that is

---

21 This is precisely the aim of the CCA, as it is expressed on the website: ‘Projects, publications and courses aim, through practice, to open up novel combinations of the historically separated domains of the creative arts and the truth-claiming discourses of history and the social and natural sciences’ (Centre for Curating the Archive, 2015b).

22 In library cataloguing terms, things are known as ‘realia’. Although Gerald Quinn used this term in relation to the object collection in his recollections of the early days of the Manuscripts and Archives Department, currently the term does not seem to be commonly used at UCT. The term ‘ephemera’ is also sometimes used, though at UCT this term is reserved for paper-based materials such as programmes, invitations, stickers etc.

23 See Yeo, 2008, for a discussion of the use of prototyping within records management and archiving practices.

24 This exhibition featured ‘... a Discharge Book for Native Labour (1920–1932); passes from the turn of the century to the 1980s; postcards depicting the lives of early Chinese migrant labourers in the mining compounds on the Rand; a silk gown robe worn by the infant Robert Gray, the first Bishop of the Cape Town Anglican Church; a walking stick carved from a wooden broom stick inside Pretoria Gaol bearing the signatures of Rusty Bernstein, Rev. Douglas Thomson, Joe Slovo, Leon Levy and Ron Press; two sets of travelling communion vessels of the Rev. Noel Roberts; letter written on toilet paper to Helen Suzman, written and smuggled by an inmate from the Zonderwater Prison in 1979; a Black People’s Convention tribute poster to the late Bantu Stephen Biko and much, much more’ (Zuma, 2011).

foregrounded, rather than any real potential they may have to produce new or different understandings of history. This is a persistent response, but also a paradoxical one: as noted above, such collections exist in many university libraries both nationally and around the world.

The UCT libraries website outlines the hierarchy of archival priorities when it describes Special Collections as ‘hous[ing] unique collections of rare books, original materials relating to African history, the papers of prominent public figures, historical maps and architectural drawings, extensive government publications from Africa and abroad, institutional archives, and Africana collections that attract scholars from around the world’ (University of Cape Town, 2015c). In this description, the approximately 200 things also held within the Manuscripts and Archives Department, now a subsection of Special Collections, do not feature as material enticing enough to scholars to warrant a mention.

Furthermore, whereas the paper-based archival material in the department is organised into fonds according to archival convention,<sup>25</sup> this only holds true for a very few of the things held in the archives. Most of the artefacts were long ago removed from any particular fonds (if they were ever actually attached to one — many were not), and were simply stored in cardboard boxes in the stockrooms. This approach persisted and still persists long after the time when they were presumably set aside, namely the years when the notion of starting a UCT museum was mooted (see Chapter Two).<sup>26</sup> It serves to underscore the artefacts’ status as slightly odd ‘extras’ that somehow defy the rules of containment and classification that pertain within the archive.<sup>27</sup>

---

25 According to Duchein, the archival principle of ‘respect des fonds’ entails ‘... group[ing] ... the archives (documents of every kind) created by or coming from an administration, establishment, person, or corporate body. This grouping is called the fonds of the archives of that administration, establishment or person’ (Duchein, 1983:64-65). The principle applies to other archival material too.

26 Interestingly, the backstory of many of the things held in the Cory Library archive at Rhodes follows the reverse trajectory of what was intended to happen to the ‘museum objects’ at UCT. These things were originally displayed in a museum in the Nun’s Chapel, curated by Ken Robinson, the retired art director of the Rhodes Theatre. On his death in 1996, these artefacts were passed on to the Cory Library (Liz de Wet, interview, 18 May 2012).

27 Bierbaum points explicitly to these attitudes towards things, as well as to the perceived awkwardness of their classification in a discussion of a 1990 survey of the extent and management of object collections in academic libraries in the USA. She comments: ‘In the case of three-dimensional objects ... acquisition depends less on planning and policy than chance and circumstance. One reason is that three-dimensional objects present particularly vexing acquisition management problems ... the medium as a whole lacks even the sketchy evaluation acquisition apparatuses provided for AV’ (Bierbaum 1990:10). Bierbaum goes on to note that, ‘another collection decision is that of housing ... Academic libraries less often physically

However, the hierarchy within the archive has effects that extend beyond the privileging of paper-based materials over things within archival finding aids and website descriptions, and beyond the relegation of the things to atypical methods of cataloguing. The dominance of paper-based material has led to the development of a set of unwritten (and sometimes written) rules in terms of what visitors do within archives, where overwhelmingly, a prescribed set of practices, chiefly those of reading and writing, hold sway. Here, my own creative responses to the object collection, exhibited on *Slantways*, represent a further departure from the given regimen of archival practices. This is made more noteworthy when it is considered that, in late 2011, the manager of Manuscripts and Archives gave me special permission to begin the process of making new versions of around 80 of the things making up the object collection for the artwork *Hoard* within the archive itself. I took up this opportunity on several occasions, using modelling clay on a large sheet of cardboard laid on one of the tables in the reading room, until I became so familiar with the artefacts that I felt able to work in my studio from photographs and memory instead. I also produced a giant map of all the objects I was working with, and made a series of smaller drawings within the archive as preliminary research for the artworks I ultimately produced.

An analogous translation or crossing of media takes place in the 'slightly off centre' methodological approach described in Michael Nixon's essay 'Depths of Field: photographs and early South African music studies', in which he presents a close reading of Percival Kirby's photographs<sup>28</sup> in relation to his ethnomusicological instrument collection (Nixon, 2014 in Hamilton and Skotnes, 2014:188-227). Nixon explains that this methodology, made useful by 'the absence of sound recordings and paucity of field notes' (Nixon, 2014:196).

... draws together the dispersed Kirby photograph collection to foreground its archival aspects as the product of the work of a single collector, who clearly saw great importance in documenting his work through visual means, and deployed iconography in his educational practice. This method enables a reading that proceeds at a slightly oblique angle to what might be expected of work with an

---

integrate 3-D materials ... objects may be dispersed, though the bibliographic records for accessing formation may be centralised' (Bierbaum 1990:10).

28 Kirby's effects, including his photographs, are held at various institutions including the University of the Witwatersrand Library and Museum Africa (Michael Nixon, email correspondence, 5 October 2015).

ethnomusicological archive (Nixon, 2014, in Hamilton and Skotnes, 2014: 192-193).

As in my own work, the oblique angle referred to above, in which artefacts that, as a result of their very materiality provide an unexpected entry point into the research process, is utilised in accessing a particular archive, and in the process allows for a surprisingly rich range of research outcomes and responses.

Not entirely separate from this point is the third way in which this study comes at a slant, namely my conscious attempt to bring into focus an archival collection that, partially because, as described above, it consists of things and is therefore considered to be of low value, and partly as a result of its colonial origins, has for many years been marginalized — in fact, has been literally out of the direct line of vision. To some degree, this starting point accords with the inclination of many artists working with archival material ‘to make historical information, often lost or displaced, physically present’ (Foster, 2004:4). However, in the case of my own body of work, I would see this reclamation or re-institution as a starting point or first move for further, open-ended creative exploration.<sup>29</sup>

In the fourth instance, absolutely central to this project was my ambition to allow the things that I had chosen to work with themselves to guide me into particular, sometimes unexpected directions.

Here, in the interest of ‘undercutting the rationale of the chronology of taxonomy ... [so that] ... objects themselves come to the fore ... [as] ... the nexus of meaning rather than its illustration’ (Macdonald, 2004:93), I took Igor Kopytoff’s conception of the close biographical writing of things as a starting point.

According to this understanding,

In doing the biography of a thing, one would ask questions similar to those one asks about people. What, sociologically, are the biographical possibilities inherent in its “status” and in the period and culture, and how are these possibilities realised? Where does the thing come from and who made it? What has been its career so far, and what do people consider to be an ideal career

---

29 The only exception to this proviso in the case of my work for *Slantways* was the work *Musa Askari* which had precisely the intention elaborated on by Foster.

for such things? What are the recognized “ages” or periods in the thing’s life, and what are the cultural markers for them? How does the thing’s use change with its age, and what happens to it when it reaches the end of its usefulness? (Kopytoff, 1986:66).

However, while Kopytoff focuses on the lives of things as they move through the world, Hamilton’s conception of biography is specifically focused not on things but on *archival* things, that is, on the changed nature of a thing once it is deemed to be part of an archive. As such, her approach had a stronger influence on the methodological route I chose to take. Since Hamilton is a theorist of the archive, she focuses on the archival artefact in the interests of theorising the archive itself. Contending that once an artefact has been archived, this change in its status to an item deemed worthy of institutional preservation reflects back on and changes understandings of its earlier existence, Hamilton relates the term ‘biography’ specifically to ‘... the period from when material is first engaged with a view to it entering some form of recognized preservatory housing’ (Hamilton, 2011:12). Further, in terms of her conception, this aspect, biography, is distinguished from what she terms ‘backstory’ — the combination of factors that are considered to have shaped the archival material prior to its inclusion into the archive in the earlier period of its existence referred to above. Hamilton cautions that ‘there is often a grey area between backstory and biography, centred on the acts of recording or collection, when active preservation is not necessarily on the horizon. However, many collections are made with an eye to a possible archival future’ (Hamilton, 2011:12).

In addition to the insights afforded by this conception, I incorporated the approaches to things adopted by thing theorists, in particular those of Brown and Bennett, so as to allow myself as far as possible to be led by the things’ own actancy. As I understood it, in keeping with my personal work experience as an interviewer on various oral life story projects,<sup>30</sup> a certain act of receptivity was required — I was, in a sense, an interlocutor of the things, trying to ‘listen’ carefully to what they were able to ‘tell’ me, before making artworks as a response to what they had revealed.

---

30 This work included the books *Balancing Act* and *I am an African*, published by New Africa Books in 2005 and 2007 respectively.

In the first instance, this process of receptivity engaged with aspects of the things' materiality — with less definable qualities, such as their age, shabbiness, taint and so on, but also with their vitality and sensuous qualities as matter, qualities that relate directly to the media they were made of. These qualities are intertwined with their affordances as things — the fact that, for instance, the cloth in the archive implied the idea of wrapping or covering, provided a ground that could be and was marked by human hands, could absorb a scent and had done so; or the fact that the gavel could be held and used to strike a surface, or that the set of pieces making up the puzzle 'The New Game of HUMAN LIFE' can be held, read, looked at and connected to each other so that they fit smoothly together to create a flat, circular plane.

With this approach, I became a co-producer with the things, in a sense collaborating with them much as an interviewer collaborates with her subjects in an oral history life stories project, rather than an artist manipulating them as inert objects, material for my greater and pre-imagined creative schema into which I would make them fit.

Though in each case the rationale and context might be slightly different, taking things as a starting point has various precedents. An important example is provided by alternative focuses in museum display over the past roughly 20 years, where, in a move away from the inflexible and unvarying imposition of a pre-imagined taxonomy as a first step towards creating a display, the quality of curiosity has been foregrounded. As Stephen Bann explains, this focus allows for the emergence of new understandings, so that displayed things become '... a nexus of interrelated meanings — which may be quite discordant — rather than a staging post on a well-trodden route through history' (Bann 2003:210 quoted in Macdonald 2006:93). A further important effect of this shift is that '... objects become more open to both apprehensions through, and analysis in terms of, the sensory or existential' (Macdonald 2006:93-94).

As discussed in more depth in Chapter Three, various artists have pursued a range of similar approaches in the context of the university and its collections. Most notable for the genealogy of this project is Pippa Skotnes, Fritha Langerman and Gwen van Embden's *Curiosity CLXXV* (2004), in which both the chip of wood associated with David Livingstone's marriage proposal and the cloth addressed by Olive Schreiner discussed here, as well as other items from the Manuscripts and Archives object collection were featured.

Arguably, an open-ended, intentionally disorderly thing-centred approach runs counter to most archival research. As institutional spaces, archives are marked by a sense of control: 'They are accessible, often by appointment, in non-public spaces. The archivist has identified an area of the collection a researcher might be interested in, but s/he must go through it physically, item by item, to find out more information' (Besser, 2004).

Furthermore, researchers generally enter an archive with some specific research intention, and use the information gathered there as evidence to support a particular argument. In the case of my own research process, I had only my desire to 'listen to' the artefacts as a starting point for a series of initially entirely unforeseen and unpredictable creative responses to them.

Finally, but very importantly, on another level, this time relating to the issue of sight loss discussed above, the adoption of a conceptually oblique methodology refers to my ongoing perceptual re-orientation to the archive and to the practice of art-making, as the result of this sudden occurrence. After a few months of serious reflection, I became aware that my new orientation presented itself as a compelling metaphor for adopting an alternative, obliquely positioned approach to challenge the inherited biases and blinkered modes of comprehension at play within the archive.

With a similar end in mind, in this case in relation to the anthropological establishment's encounters with the Other, Francis Nyamnjoh uses the allegory of the three blind men and the elephant<sup>31</sup> to point to the persistence and pervasiveness of preconceptions and prejudice:

The story is a metaphor for another kind of blindness — that which comes from preconceptions, prejudices and assumptions about what constitutes reality ... We must grant that intimate encounters with the elephant, however deep and convincing, are always approached from particular angles and perspectives, and that such encounters are further compounded by the dimensions of being an elephant that are beyond appearances ... the blind men are so focused on their areas that they are, consciously or not, oblivious to the existence of other areas ... (Nyamnjoh, 2012:64).

---

31 The three blind men each access a different part of the elephant's body by feeling it. Because they cannot see the elephant as a whole, each judges it to be something completely different.

It is the obliviousness referred to in the quotation above — perhaps most notably the obliviousness of preconceived ideas — that my slantways approach seeks to challenge and disturb in this project. Further, it is the ‘dimensions of being an elephant that are beyond appearances’ that its use seeks to explore and express in new ways — some of them ironically actually using the very sensory lack that impedes the blind men in the story, impaired vision, as a means to do so.

Returning to the context provided by my personal re-orientation in dealing with visual impairment, assuming an oblique approach specifically for the production of my artwork and for its exhibition on *Slantways* entailed the use of two strategies. Firstly, in defiance of the hegemony of the optical (Schmidt, 2002:7) so evident in every aspect of contemporary life, including scholarship and art-making, it led to a focus on producing several artworks engaging the less culturally dominant, less celebrated senses of hearing, touch and smell in my creative responses to the object collection.

The second aspect of the slantways approach to orientation in my creative work responding to the object collection is somewhat more complex. In recognition of the liminal status of partial sight, its refusal of the usual uncomplicated proposed binary of seeing normally/light versus blindness/darkness, employing an oblique angle for the exhibition meant not entirely de-privileging the visual, but proposing and embracing the ‘in-between’ ocular state of compromised vision. In other words, my effort was to incorporate and emphasise a variety of seeing states or elements referring to different forms of seeing as an aspect both of the artworks, and of their presentation. On one level, this approach simply represents an attempt to compel my viewers to stand in the shoes of others. However, on another, it can be understood as an effort to disrupt the dominant conventions still prevailing in the legacies of Enlightenment knowledge, in which the presumption of binary oppositions so often features.

Both of these strategies will be discussed in more detail as they played out in particular artworks in the final chapter.

## **Chapter outline**

### ***Chapter One***

In this chapter, I provide a first layer of context for the object collection that I worked with via an investigation of the history of the UCT Manuscripts and Archives Department, in which it is housed. In particular, I discuss the beginnings and subsequent development of the Department during the era of its founder, R.F.M. Immelman. I describe and explore Immelman's collecting rationale and strategies, and consider these in the light of his subject position as an arguably somewhat ideologically blinkered scholar librarian during the increasingly repressive years of apartheid. I also consider the blurring of the epistemological divisions between library, archive and museum that have prevailed to some extent at UCT since Immelman's time as Chief Librarian.

### ***Chapter Two***

This chapter represents a further contextualisation of the things making up the Manuscripts and Archive object collection, this time from the angle of their life as artefacts housed within an archive, and telling particular stories of the lives they have led both within this archive and out of it. I explore this terrain by considering the culturally-based theories of things put forward by a range of scholars, including Brown, Daston, Frow and particularly Bennett, whose conception of the actancy of things via their material qualities, as well as via ontologically mixed assemblages I deploy in this project. I discuss my own understanding of the qualities of the things I worked with, including their medium and other less tangible aspects of their materiality, such as their age and the taint of the colonial past they bear, which affected my personal responses to them and my choices in terms of my conceptual approach to the artworks I made. I explain the interviewing methodology I employed in getting to know these artefacts as intimately as possible, and discuss my application of Hamilton's understanding of biography in the process of biographical writing I undertook as a precursor to each of the artworks I made that responded to individual things from the collection.

### **Chapter Three**

This chapter situates the artwork I produced in response to the object collection via an overview of the curation and art-making processes various other contemporary artists have used in response to archives and archival collections both locally and globally. In particular, I discuss these artworks in light of Danburg and Spieker's conception of 'the critical archive'. I also focus on art that in some way or ways intersects with my own conceptual and methodological concerns for this project — for example, art that works specifically with things' materiality, with collections of things either assembled by the artists themselves or found within an institutional context, artwork based on eccentric, or marginalised archival source material, art that aims to challenge or upset the epistemological framing of a particular archive, art that restores subjectivities previously excluded from the archive and art that attempts to use a particular archive to explore how the past continues to be felt in the contemporary moment.

### **Chapter Four**

This chapter provides a comprehensive discussion of my exhibition *Slantways* and the body of artwork I showed on it. I begin by elaborating on the creative strategies I made use of for the exhibition. I then examine my rationale for choosing the CAS gallery in which to exhibit a body of artwork that intentionally sets out to trouble the university archive. After explaining my conception of the exhibition as a whole as the expression of an assemblage, I discuss each of the artworks I exhibited, beginning with *Finding Aid: the archive partially seen*, which, on one level, provides a conceptual framing for the entire body of work. This is followed by a discussion of *Hoard*, the centrepiece of the show and the only artwork referencing the entire collection. I consider its genesis, its first iteration on *Imperfect Librarian* in 2012 and its second on *Imaginary Fact* at the 55<sup>th</sup> Venice Biennale in 2013, where particular conditions influenced the shape it took, especially in terms of its engagement with an international audience and the display and labelling strategies used. I consider its third iteration on *Slantways* the following year, and how its display was again modified to suit this very different context, and then discuss this artwork as an assemblage, to give a sense of my understanding of the usefulness of this concept in the production

of this particular body of work.

I then discuss each of the other artworks I produced in response to individual things from the object collection, namely, the Rhodes 'deathmask', Ray Alexander's hairbrush, the 1947 recording of Queen Elizabeth's speech in acceptance of her honorary doctorate from UCT, the puzzle piece from 'The New Game of HUMAN LIFE', the miniature travelling microscope, the cloth addressed by Olive Schreiner and the chip of wood associated with David Livingstone's proposal to Mary Moffatt. Before a detailed description and discussion of each artwork, I include, following Hamilton, close biographical writing on each of these artefacts.

### ***Conclusions***

Finally, I discuss the conclusions I drew from the project, all of which relate to the deployment of my various slantways methodologies. I start with a focus on the incorporation of my disability to influence my process, and then discuss my work with a marginalised and a-typical collection. I also discuss the proposal that there is a need to understand university collections differently and to rethink the boundaries between museum, library and archive and engage with the interstitial spaces that exist between them via creative interdisciplinary projects such as this one. I then consider the effects of another vital aspect of my slantways approach, namely, my use of art to trouble the university archive. This is followed by a consideration of the actancy of archival things. Lastly, I reflect on the interplay between the archive and the present moment, in the light of the concerted campaign in 2015 calling for the transformation of the university into a more equitable post-colonial institution.

# CHAPTER ONE

## The object collection in context: a brief history of the early years of the Manuscripts and Archives Department

### **‘Many innovations’**

In a decidedly cheerful 1959 article that appeared under the heading ‘Alterations and moves at Jagger’, a young librarian, Gerald Quinn, described some of the ‘many innovations’ that had taken place and were being implemented in the main library at UCT, the latest resulting in ‘the most frightful din’ overhead even as he wrote. The first significant development took place

... when, a new MSS and Archives Division having been brought into being and a home having to be found for it ... it was decided to do some alterations in the librarian’s group of offices. Mr Immelman moved into what was then his secretary’s office, and the office thus vacated was divided into two unequal halves, the outer and larger becoming the secretary’s office, the smaller and inner becoming the home for the newly born division ... This was in February 1958 ... (Quinn, 1959:16-17).

The inner sanctum created by these re-arrangements was one of the earliest incarnations of the Manuscripts and Archives Department, although not the very first — after it had come into being the previous year, its material had temporarily been stored both in a stack room at the top of the library as well as in a strong room in the basement; but before then the elements making up the first collections of the new department were literally stored all over the library, wherever a space could be found.

In subsequent years, the Manuscripts and Archives Department has been housed in various places on UCT Upper Campus. It moved into the Immelman wing of the library in the early 1980s, and then to the Oppenheimer Institute in 1989, where it remained until 2012. It was then relocated to its current home

in the J. W. Jagger Library, as part of Special Collections, though in keeping with its past profile as an entity always in some way divided, some of its material still remains in storage in the basement of the Oppenheimer Institute and elsewhere off campus.

## **Into the archive: ambivalent beginnings**

The Department was based in the Oppenheimer Building when I first visited it 52 years after the publication of Quinn's article, in March 2011. Despite my recent attachment to the ARC programme and the APC, I was all too aware that I knew very little about archives. I felt very uncomfortable. I was blundering into my PhD, blundering into the archive, and blundering into the Manuscripts and Archives Department on a desperate quest to discover what it was all about.

My initial impressions were not happy. I was certainly fascinated by the strange collection of things I had come to investigate. At the same time, though, on my first few visits, I was also slightly repulsed by them — they seemed too old, too bedraggled, too tainted by the colonial past to which they bore witness, or would have if more people knew of their existence.

I also experienced a strong feeling of antipathy towards the archival setting itself. I disliked its smell and the hum of the air conditioning, hated the colour and texture of its carpets, and felt a strong aversion to the gloomy, chill, slightly sinister stack room behind the reading room, with its claustrophobic rows of grey metal mobile shelving, between which I felt one, might easily be pressed like a flower in a book. Because I experienced the archive as overwhelming and oppressive, for my first few visits, I found it impossible to stay there for long — after half an hour of slowly unpacking one of the old cardboard boxes and staring fixedly at one peculiar, usually context-less artefact after another, I would start longing for the world outside, make excuses to myself and hastily depart.

Fortunately for the sake of this project, I persevered, and my sense of the object collection began to gel. Over the next two months, chiefly through handling and examining the 'museum objects' both singly and in groups, but also through researching their provenance where this information was available, asking questions about them, thinking about them and photographing them, I came to know them well. My interest in the stories of their lives as material things began to overwhelm my squeamishness at their

colonial taint. Finally, my resistance dissolved entirely about two months into the project, when I became fully aware of the second layer of things in the archive — the unknown number of artefacts attached to particular fonds and ‘buried’ in its depths, to surface only when a researcher chose to examine the contents of that particular fonds. Fascinated by the things in the archive, and intrigued by the idea of making art that facilitated the emergence of and responded to their stories, I forgot all about the colour of the carpets, and began focusing single-mindedly on the process I had embarked upon.

With the aim of providing a spatial and historical context for the object collection, in this chapter I focus closely on the Manuscripts and Archives Department from the time of its first production as an archive in the 1950s to the end of Immelman’s term of office in 1970. A vital aspect of this focus is the elucidation of the ‘way in which the archive ... acts upon the world around it, having effects, and is, in turn, acted upon by the world in which it is engaged, in an ongoing process in which the subject both retains core aspects of its initial subjectivity and changes over time’ (Hamilton, 2011:332).

### **R.F.M. Immelman, scholar – librarian**

I really do want to thank you most sincerely for this very valuable collection of documents, letters, photographs etc ... as an old student who remembers “Sir Jock” with admiration for what he did for the University of Cape Town I am delighted that we now have more material in the university Archives dealing with his work. I can assure you that it will be properly arranged, filed and preserved for the future. At different times some of the material will be used for displays in locked glass cases, to show later generations of students something of the development of the university and the men who helped to build it. (Letter from René Immelman to Lady Elizabeth Beattie, dated 9th December 1954).

The establishment of the UCT Manuscripts and Archives Department in 1957 was just one facet of the major expansion and development of the university library conceived of and overseen by Immelman during his 30 years of service as Chief Librarian at UCT.<sup>32</sup>

---

32 For an overview of the development of the UCT Libraries from the earliest days of the university’s existence to the present, see the UCT Libraries website (UCT, 2015b).

After attaining his MA in German in 1930, Immelman worked in the Library of Parliament for a year, during which time he became familiar with the State Archives and the Mendelssohn Africana Collection, then held in the basement of Parliament. Acting on a suggestion that he consider a life-long career in librarianship, a profession that was then in its infancy in South Africa, he joined the UCT library as a sub-librarian in 1935. Since no local institution provided the requisite training, Immelman went to study Librarianship at Columbia University in New York from 1937–1938, after which, with the help of a Travelling Visitor’s grant from the Carnegie Corporation, he visited various American, Canadian and European libraries. In 1939, the UCT School of Librarianship was established, and in 1940, when his predecessor the Rev. George Parker retired, Immelman took over its Directorship as well as the post of University Librarian (Taylor, 1970:1-3).

Various accounts present René Immelman as an energetic, meticulous, extremely reserved but unfailingly courteous man.<sup>33</sup> He exemplified the now outdated notion of the scholar-librarian — someone who not only curated books but who also undertook scholarly research and writing (Raabe, 1983:252). He was also renowned for his enduring commitment to the promotion of libraries and librarianship in South Africa. During the 1930s he played an active part in the campaign to establish free libraries both within schools and for the general public. This work continued after his appointment as UCT Librarian. At the same time, he developed the curriculum offered by the new School of Librarianship. In the interests of providing practical support for this curriculum as well as of fulfilling his ambition to boost the research capacity and general profile of the university via the library, he set about the process of reorganising and developing what had until then been a fairly modest resource, with ten staff members and 110 000 books. He saw increasing the book stocks of the library as an essential aspect of this process, and from 1956 to 1965, the number of publications in the library increased by 47 percent (Watts, 1980:45).

Immelman’s 30 year-long effort to build a world-class library at UCT presented the perfect opportunity for the coming together of three evidently lifelong passions — a deep appreciation of books, an ardent interest in history,

---

33 For example see Varley’s obituary in *Jagger Journal* 3 ( 1982)

particularly the history of the Western Cape (Taylor, 1970:1-3),<sup>34</sup> and a talent for the process whereby, as he understood it, both could be preserved in the interests of future scholarship within the university — namely, the ongoing practice of collection.<sup>35</sup>

As a practice, collecting tends to resist easy interpretations and definitions. However, one definition that does seem useful describes it as ‘a process consisting of the confrontation between objects and subjective agency informed by an attitude’ (Bal, 1994:100). In Immelman’s case, this attitude revolved around the notion of preservation. According to Gerald Quinn, both Immelman and his colleague and friend Douglas Varley, who headed the South African Library, had an unwavering conviction of the importance of the conservation of material of historical significance, whether it was within the UCT library or not:

He was keen on preserving things for posterity that might — not necessarily would — be of use in the future ... his attitude was, “If you don’t want to give it to UCT, why don’t you give it to the South African Library?” ... he was very keen on preserving books. For example if he found a collection of books brought to the Cape by a missionary, he would persuade them to give them to an organisation ...<sup>36</sup> But he wasn’t only a book librarian, he had a much broader vision. Mr Varley had the same approach — a burning belief in the preservation of materials — paintings, magazines, newspaper clippings — so that future generations would be able to see what people in the past were like (Gerald Quinn, interview, 12 December 2011).

In the 1982 article Varley wrote as an obituary for Immelman, it is clear that,

---

34 He belonged to the S.A. National Society, the Genealogical Society of South Africa, the Cape Town Historical Society (where he held honorary life membership) and the Simon’s town Historical Society, and wrote and spoke widely on historical topics (Taylor, 1970:2).

35 When asked what Immelman liked to collect in his personal capacity, his daughter Jeanne responded: ‘anything and everything historical — mainly South African’ (Jeanne Cope, interview, April 23 2011).

36 Immelman’s extreme dedication to the preservation of books comes across strongly in the introduction to his last publication, a booklet on the Ballot-Kitcher collection: ‘When ... the books were unloaded, I was absolutely horrified by the destruction wrought by 40 years of neglect, dampness, mould and rats ... Much work had to be done over many years to painstakingly piece together innumerable scraps and tatters of paper, to match odd pages and return them to the volumes to which they belonged. It was a laborious task requiring great patience and many hours, days and weeks of sorting and matching, as volumes were slowly reassembled. Not one single piece of paper was discarded. The binders too, contributed their share, and gradually assisted in bringing order out of chaos ... Repair, restoration and binding eventually took between 10 and 15 years’ (Immelman, 1982:1-2).

for him at least, this conviction went even further than the description above suggests, amounting to ‘... the conceit that more knowledge secures a more durable empire’ (Stoler, 2009:3). According to Varley, ‘... [Immelman] ... was one of the first to grasp the importance of conserving the books and manuscripts which contain and preserve the essence of the culture upon which our evolving civilisation — if it survives — must be based’ (Varley, 1982:1).

Immelman’s inclusive understanding of the kind of material suitable for a library to collect was unusual, and at first there was some suspicion from the administrative staff with regard to his wish to collect the university’s records. Furthermore, UCT library staff members initially found both his habit of filing newspaper clippings in the library as well as his desire to collect manuscripts strange (Gerald Quinn, interview, 12 December 2011).

Immelman carried on regardless. By 1965, there were some 86 000 manuscript items in the library (Watts, 1980:45). He was still collecting in 1968, two years before his retirement, when, in the introduction to *The Handlist of Manuscripts in the University of Cape Town Libraries*, he explained with characteristic clarity and politeness that

Many post-graduate students and other research workers in universities are continually looking for subjects for theses and research, which ensures that original manuscript sources will be consulted. Donors may therefore be assured that manuscripts and family papers donated to university libraries will serve a useful purpose, as well as be preserved (Immelman, 1968:1).

He went on to make an earnest

... plea for ... the necessity to preserve letters, documents, family portraits, photographs, manuscripts, diaries, autograph and photograph albums, scrap albums, family papers of all kinds, the records of business firms or cultural societies and similar material (Immelman, 1968:1).

Such ‘pleas’ were very much part of the collecting process. Immelman was renowned for his patient petitioning for donations from whoever he considered as likely sources of interesting material. His reliance on this method of building up the book stocks is borne out by statistics: according to Barry Watts, of the 84 061 volumes added to the library’s stocks from 1956–1965, 53 percent were acquired by gift or exchange (Watts, 1980:45). In this approach, Immelman may

have been inspired by what he saw in his tour of American and European libraries.

In an early article about this experience, he wrote:

The book stocks fill one with envy when one sees the treasures<sup>37</sup> and MSS material they possess. When an author or statesman dies there is great competition amongst libraries to buy his diaries, letters etc, and in this way, very complete collections are built up, particularly if there is any local contact with the career of such a man (Immelman, 1938:171, in Varley 1982:4).

In part, though, his approach was born of necessity — when he began collecting during the Second World War and the immediate post-war period, resources were scarce and building up libraries was not considered a priority. It seems that, to the best of his ability, he turned these circumstances to his advantage, and made a habit of using this approach for as long as he worked in the library. As one of his colleagues during the 1950s put it:

Immelman showed ... that a university library is not to be measured in mere size but by the richness, variety and sheer unexpectedness of its content ... a university librarian must learn to build up his collections *without* money. Furthermore, he must not look a gift horse in the mouth ... Immelman did not turn down offers of private collections whether as a gift or as purchase because of their apparent irrelevance. He took, and actively pursued, what was available (Perry, n.d., in Taylor, 1970:5-6).

Immelman's daughter, Jeanne Cope,<sup>38</sup> as well as his former colleague, Gerald Quinn, also emphasised this aspect of his approach; and archival correspondence attests both to his patient perseverance in soliciting donations as well as to his renowned courtesy, which seems never to have failed him, even in the case of the increasingly querulous donor Miss H. M. White, who ruffled the feathers of his subordinates with impatient demands when he was unavailable to smooth over short delays in the transcription process that left her panicking about the safety of the material she had lent him (BC 247,

---

37 The word 'treasure' comes up again and again in Immelman's writings about the collections, signalling the extent of his enthusiasm about the material and his absolute conviction of its value.

38 Jeanne Cope (nee Immelman) followed in her father's footsteps, and pursued a career in the UCT library, heading the Special Collections Department from 1980 to 1985.

Correspondence between R.F.M. Immelman and Miss H.M. White, Manuscripts and Archives Department).<sup>39</sup>

One further aspect of Immelman's approach to the acquisition of material for the Manuscripts and Archives Department is worth noting. Although he lacked the financial means to pursue personal collecting as much as he would have liked to (Jeanne Cope, interview, April 23 2011), and most of his collecting took place on behalf of the UCT library, in the way he collected, he exhibited something of the private collector's unflagging appetite for the hunt, whose 'gratification admit[s] of no compromise or exception' (Nabokov, 1951:126).<sup>40</sup> Furthermore, the 'richness, variety and sheer unexpectedness' of the library material he acquired referred to above attests to the presence of a skill common to private collectors — the ability to discern the intrinsic interest in material that less practiced eyes might well have overlooked. As Etaine Eberhart, his long-time secretary put it, 'He had a very, very good eye for anything that needed to come to the library ... he knew what to get, or he saw it and thought, "We should get that"' (Etaine Eberhard, interview, 27 June 2011).

## **A note on value**

Immelman's skill as a collector raises the issue of value, and what he considered to be worth collecting so as to preserve it in the Manuscripts and Archives Department. Though this may seem paradoxical — after all, he petitioned widely for donations, and was described as never turning one down — he also had a talent for recognising items that would augment the collections and enhance their attractiveness for current students and researchers as well as those he imagined attracting in the future, and he must have had a shrewd notion of relative worth, both in monetary terms and in terms of some more elusive quality or qualities. At the same time, certain perceptions of what was valuable were obviously current in the social realm in which he operated.

At this time in South Africa, Africana was seen as the ultimate collector's

---

39 Miss White made her first donation to the University library in 1916, so that at the time of her death in 1961, she was the most long standing library donor (Immelman, 1963:13).

40 This assertion is part of an extended description of Nabokov's lifelong obsession with butterfly collecting.

prize (Gerald Quinn, interview, 12 December 2011).<sup>41</sup> This vague but ubiquitous overarching category was first popularised in the 1930s with the establishment of the Africana Museum in Johannesburg.<sup>42</sup> Though Africana was conceived of very broadly — it included material relating to anything from Cape silver and furniture to the memoirs of early colonial adventurers exploring Africa to detailed analyses of South African fauna and flora — by the 1950s it was at the same time distinguished by the extreme narrowness of an unwaveringly white ruling class colonial perspective that almost entirely excluded the history and culture of indigenous populations from its purview, or at the very best reduced them to the quaint customs of primitive peoples.

Although Immelman's writings show that he did, indeed, value Africana highly, and the competitive nature of Africana collecting at this time must have influenced his understanding of value, his collecting for the Manuscripts and Archives Department was, of course, not limited by this category. In the section on manuscripts in a booklet he wrote about the library in 1955, he enthused with as much relish about the two medieval illuminated manuscripts and the 18<sup>th</sup> Century manuscript of Voltaire's *La Pucelle de l'Orleans; poeme heroique* as he did about the pocket notebook of Captain R. Lovett Cameron, who accompanied Henry Morton Stanley when he was looking for Livingstone, or the account book which, from 1809 to 1855, 'recorded business transactions with many old Capetonians' (Immelman, 1955:70-80). In the case of these non-South African, as well as some of the local manuscripts, their value would have derived from their age and rarity, just as it would today. More surprising are the references to the many hand-written items, especially letters, penned by famous people, which 'people donated because they seemed to think they would be worth preserving' (Gerald Quinn, interview, 12 December 2011). Immelman definitely agreed with this assessment: in his outline of the UCT archival records, he describes 'documents or letters in the handwriting of well-known people, e.g. Sir Benjamin D'Urban, Sir George Grey, J. Rose Innes (first Superintendent — General of Education of the Cape Colony), Sir Langham Dale (his successor), Dr Johannes De Wet (father of Mrs Koopman's De Wet), Sir John

---

41 Quinn added that 'If it was Africana, it was always jolly expensive!' (Gerald Quinn, interview, 12 December 2011).

42 See Byala (2013:120-122) for a discussion of the origins of the term and subsequent variations in the way it was applied, particularly by R.F. Kennedy, who headed the Africana Museum from 1938 to 1968.

Truter, (first Chief Justice of the Cape) ...' and many more (Immelman, 1955:71). He also notes the holograph letters or specimens of the writing of famous literary figures, amongst them Eugene Marais, Totius, A.D. Keet, D. F. Malherbe, Boerneef, and many more, and those of numerous public figures, such as Smuts, Rhodes, Livingstone and General Herzog (Immelman, 1956:78).

The approach of collecting 'specimens' — that is, collecting single, context-less letters because they were handwritten by famous people — no longer constitutes sound archival practice, if it ever did (Lesley Hart, interview, 24 January 2012). What it does show, though, is an approach entirely congruent with a theory of collecting that suggests that once something is taken out of the economic circuit, divorced from its previous use value and made part of a collection, its true value can be revealed, i.e. the value to 'represent the invisible, and therefore have a share in the superiority and fertility it is unconsciously endowed with' (Pomian, 1990:30, in Bounia, 2004:9). This underlines my understanding of Immelman as a collector straddling the divide between the private and public realms.

## **The (partially) tainted archive**

In attempting to establish more exactly how the archive was constituted, it seems necessary at least to try to 'distinguish between what was "unwritten" because it could go without saying and "everyone knew it", what was unwritten because it could not yet be articulated, and what was unwritten because it could not be said' (Stoler, 2009:3).

Though it is probably stating the obvious to say that he was very much a man of his time, Immelman's own subjectivity, more specifically his racial and class biases, inevitably influenced the material he assembled for the Manuscripts and Archives Department, or maybe more accurately, the material he failed to assemble. It also gave a certain flavour to his overall legacy.<sup>43</sup> It is

---

43 This is a complex question. Neither Leonie Twentyman-Jones, who headed Manuscripts and Archives from 1975 to 1995, nor Tanya Barben, who worked in UCT library for more than 30 years, and retired in 2013, hesitated to defend Immelman against any charges of partiality or narrowness. According to Twentyman-Jones, 'The range of collections, both manuscript and published, which he acquired for the Library indicates how important he felt it was to acquire as wide a range of views as possible, so that students and researchers could reach their own conclusions. This after all is the role of a "scholar librarian". Sometime after he had retired I was on the committee of the CT Historical Society with him and it was clear that he was interested in the history of all who lived at the Cape' (Leonie Twentyman-Jones, email

true that his far-ranging scholarly curiosity, as well as his (now long outdated) perception of the responsibilities of librarians as custodians of knowledge for future generations, led him to amass fascinating and varied collections during his time in the library. However, this took place within definite limits. Despite his gift for spotting the unusual and his dedication to the act of preservation, his conception of what constituted historical significance with regard to South African material was narrowly defined.

Undoubtedly, the ideological terms provided by the increasingly rigidly segregated and unequal society in which he lived, which as a privileged white intellectual he does not seem much to have questioned,<sup>44</sup> played at least some part in the selections that he chose to make. For one thing, in the increasingly repressive post-1948 period, more and more material considered to be politically undesirable was banned. Though libraries could in some cases access this material, it was illegal to make it available to readers (Gerald Quinn, interview, 6 April 2012).<sup>45</sup> This may well have acted as a deterrent to Immelman in terms of the collection of political material — quite apart from his own political allegiances or his attitude to censorship, though UCT was known as a liberal institution, it still depended for its existence on Government funding, and presumably Immelman, in his official capacity as UCT Librarian, would have felt some pressure to be cautious about staying on the right side of the law.

At the same time, he was more likely to access certain material by virtue of the circles he moved in, the connections he established and the people he

---

correspondence, 26 March 2012). Barben commented that, 'If [material] had any academic value or was worth having, regardless of his politics, he would have got it' (Tanya Barben, personal conversation, 4 April 2012).

44 In terms of Immelman's campaigning work for the provision of free library services to promote free access to libraries, Patricia Clark points out that his efforts, like those of most of his colleagues in the Western Cape, took place within a racialised context that he — and they — never saw fit to challenge. According to Clark, the liberal principles of many Cape-based librarians of the 1930s and 40s did not extend to the promotion of non-racial library services, and though they used the 'liberal vocabulary of non-racialism,' they developed separate library services even before the advent of apartheid. Immelman's work fits this description, though to date I have no firm evidence of his political views i.e. of whether he had liberal principles in the first place. According to Quinn, it is 'unlikely that he was either an out-and-out liberal or an out-and-out verkrampste' (Gerald Quinn, interview, 6 April 2012). Together with his friend and colleague Douglas Varley, who was based at the South African Library, he actively championed the Society for Book Distribution, which in practice provided reading matter for white Afrikaners, notably the poor white rural population. He also worked for the Cape Libraries Extension Association, which aimed to provide libraries for the poorer section of the population in the Cape. Even in this case, the emphasis was on the provision of services for Coloured readers, though a library was started in Langa in 1943 (Clark, 2004:26-28).

45 Quinn pointed out that in Immelman's day, the Jagger Library had what was called "the Theta list" of banned books, that was kept in Special Collections.

considered worthy of petitioning for donations.<sup>46</sup> His correspondence suggests that his efforts to solicit donations were largely directed at the eminent upper class white families of his day. The fact that, for Immelman, these were the people whose lives were interesting, meaningful and worth remembering inevitably made for a partiality in terms of his otherwise astute collector's selections, and resulted in definite lacunae or silences in the Manuscripts and Archives Department collections, at least in those that were brought into the library during the first 15-odd years of its existence. With very few exceptions, the material assembled in Immelman's time represented black South Africans only as the subject of ethnographic research or as an undefined mass making up the Zulu army, the 'Native question' or in subsequent years, the 'Bantu' who in terms of the racist politics of the day were understood to require increasingly punitive legislation in the interests of control.<sup>47</sup>

Another factor that played a part in determining what was and what was not collected was the fact that, at this time, the Cape Provincial Archives were very active in collecting political material, with the result that the university archives focussed more on local history and literary material (Gerald Quinn, interview, 6 April 2012).

This point is not unrelated to a last aspect of Immelman's constitution of the Manuscripts and Archives collections, that is the question of how a man of his generation known to have loved the study of history understood the scope of his subject — in other words, how he defined history. The collections made during his era do contain some material that was then fairly recent. Mostly, however, although Immelman might have considered the unfolding social, political and economic developments of his own era as being of significance, he was far more focused on the history of the 19<sup>th</sup> Century and the early years of the 20<sup>th</sup>. This is not merely reducible to a question of his temperament and tastes. Quinn recalls that

When we were taught history, there was no such thing as contemporary history — it was less important than it is today. We did collect modern stuff, but not much. Even with the literature, we were far more likely to focus on Olive

---

46 It is important to bear in mind that there is a certain element of chance at play in collecting, so that, like all collectors, Immelman could only collect what he was able to encounter.

47 This is not to suggest that this material necessarily represented Immelman's own political views.

Schreiner or Pauline Smith than, say, Andre Brink (Gerald Quinn, interview, 6 April 2012).

It is also unlikely that Immelman would have been exposed to the shifts in historiography that began to occur just as he was retiring (Chris Saunders, personal communication, 5 April 2012).

## **The archive in the library**

Howard Besser points to the ‘... fundamental differences in mission, in what is collected, in how works are organized, and in how the institution relates to its users’ pertaining between museums, libraries and archives’ (Besser, 2004). He explains that

The traditional library is based upon the individual item, but it is generally no (sic) unique. Archives manage groups of works and focus on maintaining a particular context for the overall collection. Museums collect specific objects and provide curatorial context for each of them. These distinctions of the fundamental unit that is collected and why affect each institution’s acquisition policy, cataloguing, preservation, and presentation to the public (Besser, 2004).

Besser goes on to note that, in contrast to libraries, which are user-driven, museums are curator-driven, while archives focus on research (Besser, 2004).

This assertion may well hold true in the case of many or even most institutions providing a home for collections. However, in terms of the history of the UCT Manuscripts and Archives Department (in particular as far as the things are concerned), the divisions referred to have been less distinct, or perhaps have been applied in principle, though often over-ridden in practice. In particular, the various small-scale exhibitions of things mounted over the years in different parts of the university (Etaine Eberhard, personal communication, 2 July 2011) show that the distinction was never seen as absolute.<sup>48</sup>

This blurring of boundaries originates in the haphazard nature of

---

<sup>48</sup> It should be noted that this distinction has also not been followed consistently in the case of the South African National Archives. In the Western Cape, for example, during the 1980s, things donated to the archive were re-housed at the Cultural History Museum, but after 1994, this policy fell away. Currently donations of artefacts are still sometimes accepted into the archive.

Immelman's collecting process, based mostly on the goodwill of donors and his own gifts of persuasion, (though some collections were also purchased). Other factors include the practical constraints imposed by lack of space and funding (Drew, 1981:45),<sup>49</sup> limitations on the number of staff members available and the far broader sense of the nature of the library prevailing in the 1950s and 1960s, at least as far as university libraries were concerned.

According to Quinn,

Immelman had been collecting documents in a desultory way for years. When anyone told him about some documents sitting in a loft on a farm, he would persuade them to give them to the library ... By 1957, we were storing these manuscripts all over the place in dark little corners and cupboards in the library — there was floor upon floor of the stuff (Gerald Quinn, interview, 12 December 2011).

The same gradual accretion of material had taken place in terms of the university archives collection — material relating to the history and day-to-day running of the university itself and its predecessor, the South African College, which was assembled from various locations in 1953, when it was housed in the new Special Collections Department.<sup>50</sup>

Out of this messy collecting process, the Manuscripts and Archives Department (then Division) was formally constituted in 1957. According to an article Quinn wrote in 1961,

... we have ... split things up, the Archives being housed in the Strong room in the basement, the MSS living in Stackroom 11 in a collection of, at present, 18 large metal trunks, the key to each of which is exhaustively labelled with the contents of the trunk. There are also two large steel cabinets in the office,

---

49 These constraints were still present in the early 1980s, and an article written by university administration archivist John Drew in 1981 bemoans the fact that '... the University Archives find themselves in a far from satisfactory situation. With space for storage in the library being severely limited and that in Bremner now virtually non-existent ... it has not been possible to extend the service to the faculties or teaching departments to any degree ... Nor has it been possible to do any processing of the original archives in the Jagger library, apart from some 62 cubic feet of SRC records ... These, to all intents and purposes, are still administered by the staff of the Manuscripts and Archives Division, and are likely to be so until all sections of the University Archives are housed under one roof or more staff can be obtained ... meanwhile requests for the staff situation to be improved have fallen on deaf ears' (Drew, 1981:45).

50 Special Collections also housed various other collections, such as rare books in English as well as various other languages, the Africana collection, consisting of around 3000 articles, and children's books and educational textbooks (*The Jaggerite*, (15) 1953:7).

which are used for housing new material being listed or older material much in demand and therefore kept near at hand for convenience. In the office are also the Archives information files and collections of individual MSS letters (Quinn, 1961:24).

Here again, the ideal orderly divisions put forward by Besser seem somewhat to have fallen by the wayside — though there was some effort to separate the manuscripts from the university archives, practical issues meant that this separation could not be absolute; and besides, there were manuscripts whose contents related to the university itself, along with the other archival material relating to organisations outside of the university<sup>51</sup> — not to mention the defiantly unruly artefacts — paintings, cartoons, busts, badges, medals, commemorative plates and more quirky memorabilia — some of which related to the University or to the South African College, some of which related to particular manuscript collections, and some of which had no evident relation to either. Quinn recalls that

Some of the donations that came in were in an incredible mess, others not. Apart from the letters, there were other things — photographs and horrible letter books that were the devil to deal with — you had to index them from the beginning to the end. Mainly, the stuff dated to the late 19<sup>th</sup> Century ... people would stick stuff into scrap books ... We also got quite a lot of literary things ... often by the time we got to it, the origins were lost in history — there were things that had been lying around for more than 20 years. There were haphazard acquisition records then, especially in the old days — the point was more to make sure that it didn't get lost, just to preserve it (Gerald Quinn, interview, 12 December 2011).

According to Leonie Twentyman-Jones, who headed the Department from 1975–1995, the provisional nature of the arrangements with regard to housing the collections as well as to caring for them described above continued — with small alterations here and there — until late in the 1970s, mostly due to

---

51 This is still the case today. Though the University Archives, consisting of the early records of the South African College as well as UCT administrative records are now housed in their own separate archive in Mowbray, the Manuscripts and Archives Department still keeps papers donated to it by academics as well as UCT exam papers and various ephemera relating to UCT. There is no explanation given for this division of material.

financial constraints:

Very often student assistants were employed to help with basic sorting, and collections were ... locked away in a room at the top of the Jagger library. Access for researchers was by prior arrangement ... Etaine Eberhard (Mr Immelman's former secretary) worked there full-time with another elderly library assistant who had been a secretary in the School of Architecture "... The person who 'ran' it before me<sup>52</sup> was a librarian who worked half time in the African Studies Department and half time in Manuscripts ... I was there full time so was able to do more work and gradually the department expanded and was given more staff. It was always a battle to get posts in those days" (Leonie Twentyman-Jones, email correspondence, 27 March 2012).

## The museum in the library

Both during Immelman's era as well as in the 1970s and 1980s, in addition to the busts and portraits of university rectors and other luminaries — most notably Rhodes — all over the library, it was not unusual for the Manuscripts and Archives Department to undertake displays of their material, either to commemorate what were considered to be important anniversaries<sup>53</sup> or occasions, such as the donation of the Kipling collection to the library, or on university open days. Material was showcased in exhibition areas outside the offices of the University Librarian and other senior staff, as well as outside the African Studies Library and Rare Books and Special Collections Department. The Manuscripts and Archives Department evidently kept a record of all the displays they mounted (Leonie Twentyman-Jones, email correspondence, 7 June 2011) though this seems to have disappeared at some point, along with plenty of other archival material — for example, the gas bottles that Twentyman-Jones collected when police teargassed students on Upper Campus in the 1980s. These displays may have been on a modest scale, but they still indicate a desire at this time to show the university's collections, rather than keep them hidden in

---

52 After Quinn's departure for the Rhodes library in 1971.

53 A good example is provided by the exhibition held in 1955 to mark the centenary of Olive Schreiner's birth. For this event, seven display cases, each representing a different aspect of Schreiner's life were on view in the library foyer. Amongst the things on display were Schreiner's amethyst brooch (*The Jaggerite* (17) April 1956:4). There is no mention in this article of either the moonstone bracelet or the addressed cloth that I discuss in my work below *Sense of Place 1*.

the archive, as was the case for the first few years of my PhD project. However, it is difficult to establish whether Immelman or anybody else during his period as University Librarian had the intention or even the hope of establishing a fully-fledged museum, to house and display the ‘treasures’ that had been assembled with such dedication. Though the things within the Department were referred to as the ‘museum objects’ in the finding aid, as noted in the introduction, this was a common designation for such items in that era, and does not imply the intention to display them full-time (Gerald Quinn, interview, 12 December 2011).

The fact that most of the contents of the boxes of artefacts were separated from the collections that they originally belonged to<sup>54</sup> is potentially more significant, (though according to Lesley Hart, this practice, noticeably unsound in archiving terms, is also discernible in the way a few of the early collections were constituted: for example, letters were removed from various other collections to be assembled as part of the Olive Schreiner collection). This might, perhaps, signal the desire to use them as the basis for a museum; but it might also simply show that, for some reason, these items were never returned to their original collections after they were used in various displays.

Whatever the meaning of the separation of most of these things from their original collections, close scrutiny of records in the Administrative Archive relating to the issue of the creation of a UCT gallery/museum reveals nothing before 1979, when the topic initially arose. It was raised again the following year and debated intermittently thereafter, though in later years the focus was largely on a gallery to house the university’s art collection (University Archives, minutes of the Works of Art Committee 1975–1992). Ultimately, however, no agreement was reached in terms of the need for a gallery, and nothing came of this discussion.

At least the need for a museum to house the university’s object collection, the lack of a positive outcome to these debates is not particularly mysterious. By the late 1970s, not even the most resolutely blinkered observer would have been able to ignore the fact that the era presided over by Immelman was receding fast; and by the early 1980s, the Manuscripts and Archives Department had undergone a sea change. The idea of soliciting for donations had fallen out of favour with the Chief Librarian, presumably because the library

---

54 Only a few were donated as single items, mostly by Immelman himself.

was now well stocked, and because the wooing of potential donors was a time consuming business. At the same time, perceptions of librarianship itself and the nature of libraries had changed — the librarian was now understood to be a specialist administrator rather than a scholar in his or her own right. Most importantly, in response to the increasing political turmoil of the times, much of the material entering the archives was of a different nature altogether — the focus was now more on collecting the papers of organisations, protest groups, trade unions and Cape-based political trial records (Leonie Twentyman-Jones, email correspondence, 7 June 2011). In a sense, democracy was beginning to infiltrate the archive. Under these conditions, the university collections must have seemed less appropriate and less ‘displayable’ than they had previously. For a time, they even perhaps became somewhat embarrassing. The Rhodes memorabilia, once so prominently displayed all over the library, was packed away, and the idea of creating a museum to exhibit the Manuscripts and Archives Department’s ‘treasures’ was quietly abandoned.

## **Returning to the boxes**

These, then, were the conditions prevailing in the library at the time of the creation and ongoing development of both the Manuscripts and Archives Department and the object collection that was housed within it. In the following chapter, I shift my approach to the contextualisation of the things in the archive by taking, as it were, one step towards them. To explore the very aspect that makes them stand out from the other collections in that archive — namely their life as material things — I engage with the work of theorists interested in things and their actancy, and apply these insights to the things making up the object collection that I worked with for this project.

## CHAPTER TWO

### Things and their actancy: applying a range of theoretical understandings of things to the Manuscripts and Archives object collection

Today

Oh! kangaroos, sequins, chocolate sodas!

You really are beautiful! Pearls,

harmonicas, jujubes, aspirins! all

the stuff they've always talked about

still makes a poem a surprise!

These things are with us every day

even on beachheads and biers. They

do have meaning. They're strong as rocks.

Frank O'Hara

[1950]

#### The potency of things

As the poem above avows, non-human things<sup>55</sup> are both ever-present and persistently potent in the human world. Since my PhD project is directly concerned with a primary set of things — the peculiar, jumbled selection of artefacts making up the Manuscripts and Archives object collection — as well

---

55 In considering an animal as a thing, O'Hara expresses an idea that has lost currency in contemporary thinking: Bennett, referring to Kafka's work, points out that since the time in which he wrote, '... the gap between human and animal has narrowed even further as one after another of the traits or talents thought to be unique to humanity are found to exist also in nonhuman animals' (Bennett, 2010:53).

as with a second, as it were resulting set of things, the artworks I made as a creative response to them,<sup>56</sup> questions relating to the properties, powers, effects and agency of things, and how these can be facilitated to reveal themselves in the interests of a creative process are central to this study.

Both Karl Marx's theorization of commodity fetishism<sup>57</sup> and Jean Baudrillard's work in the 1960s and 1970s on things and consumerism<sup>58</sup> examine the properties and effects of material things in terms of their exchange value (in Marx) and consumption (in Baudrillard) under the capitalist system. More recent culturally-based analyses, which have been mobilised across multiple disciplines, including literary studies, geography, scientific studies, archaeology, anthropology, history and art history, remain faithful to a materialist (though not necessarily historical materialist) starting point. However, in contrast to the analyses of Marx and Baudrillard, in an effort to understand 'the subtle incrustations of intention and invention, fantasy and ideology, tradition and accident that ... an object carries in the train of its existence' (Schnapp, 2001:246), these contemporary materialist theoretical approaches examine and discuss things in ways that allow them to speak of more than their trajectories and roles as commodities. Instead, the focus has been enlarged to include not only things' economic but also their symbolic value, as well as the complex networks of meaning within which that value is defined and expressed.<sup>59</sup>

---

56 Strictly speaking, a third set of things was involved too — the assistive devices and technologies outlined in the work 'Body Map: the archive partially seen'. I will discuss what I understand to be the assemblage involved below.

57 As Frow explicates, 'The structure of the commodity, in which the particularity of use-value is subordinated to the abstract universality of exchange-value, effects a mystified conversion of 'the social characteristics of men's own labour' into what seem to be 'objective characteristics of the products of labour themselves'. Persons and things both become thing-like, and the causal relation between work and value is inverted' (Marx, 1976:164-165, quoted in Frow, 2001:274).

58 See *The System of Objects* (1968) and *The Consumer Society: Myths and Structures* (1970), in which Baudrillard integrated semiology within a Marxist framework to analyse things in terms of consumption.

59 See Hicks and Beaudry (2010:Introduction). The authors caution that though these different disciplines work with things in ways that overlap '... key texts are read through disciplinary traditions, and their reception diverges as particular disciplinary methods are put into practice ...' This means that the study of things from a materialist perspective cannot simply be flattened out as though it was one uniform approach.

## **‘Things’ versus ‘objects’**

A silk tie, a gavel, a hairbrush, a chip of wood, a ceremonial sash, a miniature microscope, a fountain pen, seven old labelled bottles containing greyish powder or the dried out residues of dark liquids, a wallet and calling cards ... as these random examples suggest, the elements making up the object collection I worked with would all commonly be described as ‘things’ in the vague, everyday sense of the word. Equally, though, they might be called ‘objects’. In this thesis, I have sought to distinguish between these two terms and what they denote by avoiding the term ‘object’ with its dualistic connotations,<sup>60</sup> and instead using the term ‘thing’.<sup>61</sup> However, the extreme elasticity of the term ‘thing’, even in academic writing, where it has been used to refer to artefacts as commonplace, simple and ubiquitous as a paper clip or a button<sup>62</sup> and as complex as an island<sup>63</sup> — makes it tricky to pin it down with a precise definition.

## **The strangeness of things**

There is, in fact, no universally agreed upon set of characteristics defining a ‘thing’. However, the loose definition supplied by Brown was a valuable starting point for the purposes of this project. The first element of this definition is liminality, a ‘... hover[ing] ... over the threshold between the nameable and unnameable, the figurable and unfigurable, the identifiable and unidentifiable ...’ (Brown, 2004:5). The second is excess — that which ‘... exceeds ... [things] ... mere materialization as objects or their mere utilization as objects — their force as a sensuous presence or as a metaphysical presence, the magic by which objects become values, fetishes, idols, and totems’ (Brown, 2001:5).<sup>64</sup>

Brown’s expression of a generalised uncanny quality distinguishing things from objects, often made evident in moments where particular items suddenly

---

60 As Bennett elaborates, one of the problematic effects of the dualism prevailing in the structure of language is that activity is routinely assigned to subjects, while conversely objects are assumed always to be passive (Bennet, 2011).

61 Sometimes for sake of the flow of writing/reading, I also use ‘artefact’. I am aware that this term too, connotes a certain passivity, but feel that it has the merit of not automatically implying a subject and object opposition.

62 See Connor (2013).

63 See M. Norton and Elaine M. Wise’s ‘Staging an Empire’ in *Things that talk: object lessons from art and science* (2004), which concerns Peacock Island in the Havel River near Potsdam between 1793 and 1830.

64 Also see the online interview with Bill Brown entitled *The Nature of Things* (Brown, B. 2010).

cease to operate successfully, break or become strange in various other ways, is expressed in slightly different terms by W.J.T. Mitchell, for whom, according to Bennett, the term ‘thing’

... [signals] the moment when the object becomes the Other, when the sardine can looks back, when the mute idol speaks, when the subject experiences the object as uncanny or feels the need for what Foucault calls “a metaphysics of the object”, or, more exactly, a metaphysics of that never objectifiable depth from which objects rise up toward our superficial knowledge (Bennett, 2010:2).

Using similar terms (a ‘slightly creepy what-is-it-ness’), Plotz makes the point that

Thing theory ‘... ought to highlight approaches to the margins — of language, of cognition, of material substance ... limit cases at which our ordinary categories for classifying signs and substances, meaning and materiality, appear to break down’ (Plotz, 2005:110).<sup>65</sup>

It is interesting to note that this is also the way in which artist Penny Siopis understands and works with things: ‘in a nutshell, my encounter with objects is an encounter with that strange familiarity we call the “uncanny”. Objects are sentient things that force us to think and reflect on our relations with the object worlds we inhabit’ (Siopis cited in Mbembe, 2005:124).

This understanding seems apposite to my project, to the extent that it names qualities present in both the collection as an (abandoned and marginalised) whole, as well as in many of the artefacts I worked with individually: the rather sinister and, in fact, horrid Rhodes ‘deathmask’ that is not a deathmask at all, the 78 RPM record that is never played; the addressed piece of cloth originally treasured for being impregnated with a smell that no longer exists; the fetish-like chip of wood and the miniature microscope that is doubly not what it seems — firstly because it folds itself up, hides itself away and presents itself to the world as a wooden box, and secondly because within the archive it is wrongly associated with the voyage of the Beagle.<sup>66</sup>

---

65 Plotz also makes the case for thing theory to be understood not as an inter-disciplinary approach but an extra-disciplinary one (Plotz, 2005:118). Again, this resonates strongly with my project and its slantways approach to a university collection that is not associated with any teaching discipline.

66 The fact that it disappeared without trace for more than a year during the course of my project for me only

## Material markers

However, for me, the things' material presence, at least when I encountered and worked with them from 2011 to early 2014,<sup>67</sup> was also constituted by other qualities, though in some cases these were slightly elusive. Their age, and the state of slight disrepair and decay in which I found them was certainly a strong factor. They were all a little battered and worn, had definitely seen better days: the leather wallet was dry and brittle, the puzzle box was broken, the silk tie faded, some of the beadwork damaged, the addressed cloth stained, the fragile wax seals cracked, and so on. For me this called up a strong response. Though, from my first encounter with them, the things interested me, I also experienced a degree of aversion to them. In a different context, for example that of a second-hand market, in which the things would be understood still to have exchange value and even in some cases potential use value, this sense of their shabbiness, possibly because I would have associated it with movement and change, would not have mattered to me. However, when this quality of decrepitude was combined with the reality of their consignment to five old cardboard boxes in the archive, where they were seldom seen or touched, it gained a potency that for me translated into a certain ineffable melancholy. In a strange way, I pitied the things and wished to help them to release their own stifled potential.

## The taint of the past

To this disquieting aspect of the things' materiality can be added another. From the outset of the project, I was aware that, to a greater or lesser extent, the colonial origins of most of the artefacts in this collection inevitably imbue them with a certain pervasive taint. This sense of these things' complicity in a disastrously oppressive history affects and will always affect their stories and how they are perceived. A similar, more intense version of this effect is powerfully evoked in the travelogue *Shadow of the Silk Road*, when a Chinese shopkeeper offers the writer Colin Thubron a roughly four decade old little red

---

added to its vague sense of mystery.

67 The approach to the things and their care has altered in the archive since I began this project, as I will discuss in the conclusion.

book, inscribed with the name 'Yang Shao Ming':

Then an old unease came over me, the terror of the Cultural Revolution, its unknown millions persecuted. Its hallmark mental cruelty had never quite left me ... I fingered the book tentatively, almost with reverence. It seems to breathe a corrupt manna. I remembered photographs of Mao Tse Dong haranguing the red guards in Tiananmen Square, and the ocean of red books lifted to worship him. Had this been one of them? It felt rough and small in my hands. In the back it enclosed a yellow newspaper cutting of Mao's thoughts, and as I fingered its paper, that nightmare became real again and I wondered what had happened to Yang Shao Ming and what he had done (Thubron, 2006:10).

Since the Manuscripts and Archives collection consists of less obviously iconic artefacts, their own 'corrupt manna' is not nearly as potent. Nevertheless, particularly with things like the Rhodes 'deathmask', the gavel that once belonged to Gideon Brand Van Zyl, the Governor of the Union of South Africa from 1945–1950, and the set of miniature Rhodesian postcards,<sup>68</sup> with their suspect depictions of rural Africans as specimens belonging to the natural world, the things' fateful associations with the colonial and apartheid past does seem to have left an almost tangible lingering ideological residue. Although I had no desire to rehabilitate or redeem these things (which in any case would have been impossible), it was clear from the beginning of the project that it would be necessary for me to make every effort consciously to confront this taint in the artworks I produced, rather than ignore or avoid it.<sup>69</sup>

### **The things' affordances**

A slightly simpler aspect to the things materiality, in terms of their size, shape and scale is the question of their affordances — those actions which, in relation to human beings, they either call for or suggest are possible. As James Gibson explains, 'the affordances of what we loosely call *objects* are extremely various ... Some are portable in that they afford lifting and carrying, while others are not. Some are graspable and others not' (Gibson, 1979:133). Gibson goes on to

---

68 These were produced to commemorate the centenary of Rhodes' birth.

69 See the discussion of the artworks in Chapter Four.

give the following examples of things' affordances:

An elongated object of moderate size and weight affords wielding ... a rigid staff affords leverage, a pointed elongated object affords piercing. A graspable rigid object of moderate size and weight affords throwing. An elongated elastic object, such as *fibre, thread, thong or rope* affords knotting, binding, lashing, knitting and weaving (Gibson, 1979:133).

In terms of my creative responses to the things making up the object collection, their affordances were in most cases instructive and interesting, but did not directly affect what I chose to make.

### **The things' medium and its effects**

Another important aspect of the things' innate materiality, which, in contrast to their affordances had particular effects on me in terms of the artwork I ultimately made in response to them, was constituted by their medium or media — the different materials from which each of them is made, either naturally or via human production, or sometimes by both.

Here Bennett's focus on the innate vitality of different materials is very useful. The broad aim of Bennett's work is to disrupt the widespread dichotomous conception that presents humans as the possessors of vitality, and matter (and therefore things) as being dead or inert (Bennett, 2010).<sup>70</sup> In contrast, Bennett's aim is to re-conceptualise matter as the possessor of properties that allow it too to be understood as vibrant.<sup>71</sup>

Part of this conception relates specifically to the invisible, particularised energies of different materials. Bennett points out that, although we as humans are for the most part unaware of the innate energy that exists in materials, cannot see it and find it difficult to comprehend, it is nevertheless always present, constituting a '... creative materiality with incipient tendencies and

---

70 Also see recorded lecture (J. Bennett, 2011), in which Bennett analyses the relationship between hoarders and their collections to further understand 'thing power'. To this end, Bennett considers the qualities of the slowness of decay of things, their porosity i.e. their tendency to connect to or fuse with other bodies, including human ones and what she terms 'the human inorganic' — a form of sympathy between bodies usually assigned to different categories, named as 'advenience' by Barthes (Bennett, 2011).

71 Bennett defines vitality as '... the capacity of things ... not only to impede or block the will and designs of humans but also to act as quasi agents or forces with trajectories, propensities, or tendencies of their own' (Bennett, 2011:viii).

propensities, which are variably enacted depending on the other forces, affects, or bodies with which they come into close contact' (Bennett, 2010:56).

In a 2005 interview with Achille Mbembe, artist Penny Siopis points out these material energies play out in ways both obvious and more subtle in her artworks in which things are a central feature, referring to the '... confusion between "thing" and "sign,"' in both her paintings and collecting, which she understands as a constant and intrinsic feature of her work (Mbembe, 2005:119). Likewise, the materiality of the things making up the Manuscripts and Archives object collection is central to my own work for this project, and the oscillation between 'thing' and 'sign' referred to by Siopis was certainly present in my research 'interviews' with the things. So, for example, the gold top of the pen with which the British Queen signed the visitors' book in the library in 1947, fitting onto the smooth, hard black material of its barrel not only reads directly as 'pen', but also has a certain sensuous register and resonance, entirely different to that of the roughly carved little chip of almond wood, the silky, cold contours of the moonstones said to have belonged to Olive Schreiner or the slightly distasteful yet oddly compelling strands of hair remaining in Ray Alexander's hairbrush.

These differences in media call up different responses that relate to something other than their affordances, perceived function or symbolic value. For example, the plastic hairbrush in the archive would not have seemed quite as anomalous had it been made of materials more traditionally associated with commemorative gifts, such as silver and tortoise shell, like its companions. The case of the chip of wood is different, as it has no perceivable function. However, it is still the case that if it had been a chip of marble, it would not have led me as a researcher to engage with the idea of the tree it was chiselled out of, and the forgotten man who had cut it down would not have emerged as the subject of an artwork. As a final example, it is interesting to consider the cloth addressed by Olive Schreiner. Since fabric more than other packaging material that might have been used has the capacity to absorb and retain strong odours, the issue of the smell associated with the cloth would never have arisen had it been a piece of some other material, such as brown paper. As a result, it would not have led me to imagine and then make an artwork focused on the smell of wood smoke.

## Listening to things' stories

Though contemporary culturally-based approaches to things understand them as being profoundly entangled with human subjects, Daston asserts that a cultural materialist approach reaffirms the importance of things' *own* stories: from this perspective, they are no longer obliged 'merely ... [to] ... echo what people say' as historically they were forced to do under the reign of Cartesian anthropomorphism, which assigned language exclusively to humans (Daston, 2004:11). Daston explains that

It is neither entirely arbitrary nor entirely entailed which objects will become eloquent when, and in what cause. The language of things derives from certain properties of the things themselves, which suit the cultural purposes for which they are enlisted. It is neither the language of purely conventional connections between sign and signified, nor the academic language of perfect fit between the two. (Daston, 2010:15).

John Frow speaks more explicitly of things *as* stories. He relates his understanding of this concept to 20th Century phenomenology, as well as to the tradition of poetic writing represented by Rilke, William Carlos Williams, Pablo Neruda and Ponge

... which sought, in reaching back to the thingness of things, to free them from their merely instrumental status in a world of human uses ... The thingness of things posited in this discourse-its stuff, its matter, whatever it is that subsists behind and beneath accident, contingency, time, and the weave of knowledges and uses that give them to me-is like a dream of immortality, of inherence and persistence beyond all change. Endowed with an interiority and a memory, things become stories (Frow, 2001:273).

This gesture towards a more inclusive understanding of things' ability to express meaning provided a very useful way into eliciting the stories of the things from the Manuscripts and Archives object collection without giving in to the temptation of fitting them into any imposed overarching thematic narrative of my own in advance; and simultaneously, its emphasis on listening also paved the way for my focus on the sensorium in the body of work I produced for *Slantways*.

With the aim of allowing their stories to emerge, for the initial research phase of the project, I considered myself as the things' interlocutor, an interviewer patiently drawing out the experiences, events and entanglements that shaped a number of subjects in a life stories interviewing project. This process took place via a close engagement with their materiality, but it also incorporated what they looked like from different angles, what it felt like to handle them, their affordances and how they resonated with one another when I placed them in particular ways. It also sometimes included an engagement with archival meta-data about them, as might happen in an interview with a well-known person. As in any interviewing project, subjects' responses differed. Some, like the Rev. Dowthwaite's wallet or the white plaster cast of a small human hand simply refused to reveal much, and their interviews were excluded from the project. Others, like Ray Alexander's hairbrush, were open and garrulous, subjects that had lived busy and interesting lives and had much to share. Others, like the Rhodes 'deathmask' and the record associated with the Queen's acceptance speech in 1947, were more reserved, and took patient coaxing and long hours of research and consideration before anything interesting emerged; while yet others, such as the chip of wood, initially came up with information that did not, on the face of it, amount to enough. One, the cloth addressed by Olive Schreiner, had an interesting narrative associated with it<sup>72</sup> that opened up an intriguing sensorial terrain. In some cases, these interviews led me directly to the final artworks. In others, where the things' were less assertive in their revelations, the route was more circuitous.

The concept of the 'cultural biography' of things gave this notion of 'thing interviews' more substance. My starting point in this regard was Kopytoff's emphasis on understanding a thing '... as a culturally constructed entity, endowed with culturally specific meanings, and classified and reclassified into culturally constituted categories' (Kopytoff, 1986:68).

While this approach can incorporate the analysis of things both as commodities, as well as outside of circulation, as is the case with the Manuscripts and Archives object collection, Kopytoff does not distinguish between archival artefacts and other things, and does not take into account the change in status afforded by accession into an archive. In this regard, as

---

72 See Chapter Four.

discussed in the introduction, my understanding of how to write the things' biographies was refined by the incorporation of Hamilton's approach to the biographies of things within archives. In this conception, by virtue of having been accessioned into an archive, artefacts gain the ability to alter how their own pasts are understood. Hamilton considers this a form of agency. (Hamilton, 2011:319-341).

In accordance with this approach, my process did not stop with what I could discover of the things' stories before they entered the archive, or what Hamilton names as their backstories. An Important part of my process was also to consider their post-accession adventures (or misadventures) within the archive, since although they were long de-prioritised and even slightly neglected, they have not remained static but continued to evolve — in the values ascribed to them, in the way they have been displayed or hidden away, dumped in cardboard boxes, moved into safes, lost and then found again, or very recently revived and re-housed in new, custom-made acid-free containers. As Hamilton and Skotnes explain this process,

... archival materials shape and are shaped by, reshape and are reshaped over time by, changing public, political and academic discourses and practices (Hamilton, 2011). The archive is understood then to be a process of production and reproduction over time, subject to multiple, changing forms of curation (Hamilton and Skotnes, 2014:8).

This process was particularly relevant for my research into the biography of the Rhodes 'deathmask', which had been celebrated and displayed before being removed from the public eye and even ultimately arguably disavowed within the archive, as Rhodes' popularity in South African society wavered, waned and then plummeted. The Rhodes 'deathmask', when approached biographically, clearly reveals, perhaps even exemplifies one aspect of the extreme slipperiness of things, namely their tendency to outgrow their original narratives, and express an entirely different set of meanings at different times in their existence — what Thomas describes as 'the mutability of things in recontextualisation' (Thomas, 1991:28 quoted in Daston, 2004:17).

While the process of writing cultural biographies was certainly valuable in getting to know the things I was working with really well, I never understood it as a finite process that exhausted all possibilities. Instead, I considered it as a

first step, preceding a whole range of creative options that might successfully facilitate the archival things' communication.

### ***Slantways* as an agglomeration of assemblages**

Lastly, I came to perceive Bennett's conception of the assemblage as a very helpful way of understanding the overall set of linked processes constituting this project. For me, the term incorporates the object collection and the things' effects on me, my interviews with and subsequent biographies of certain key artefacts, as well as my subsequent creative responses in the form of the body of work exhibited on *Slantways*. It also includes the various other people involved in this project in one way or another.

To express her particular vision of the agency of things, Bennett makes use of Bruno Latour's term 'actant'. It is important to note that this term does not discriminate between human and non-human sources of action. Instead, an actant 'is that which has efficacy, can *do* things, has sufficient coherence to make a difference, produce effects, alter the course of events' (Bennet, 2010:viii). Bennett elaborates on the properties of humans as actants by explaining that 'human power is a kind of thing power' (Bennett, 2011:10) — in other words, human beings are not separated from the world of things, but in our everyday lives, things, such as food and minerals, work through and within our material bodies to produce effects on us and indirectly on our surroundings.

An assemblage is made up of a combined set of such actants. Bennett notes that its '... efficacy or agency always depends on the collaboration, cooperation, or interactive interference of many bodies and forces' (Bennett, 2010:21). Crucial to this conception is the idea that agency is 'distributed across an ontologically heterogeneous field, rather than being a capacity localized in a human body or in a collective produced (only) by human efforts' (Bennet, 2010:23).<sup>73</sup>

---

73 Bennett understands the human body itself as being an assemblage in combination with things most notably the elements making up the food that sustains us: 'The activity of metabolization, whereby the outside and inside mingle and recombine, renders more plausible the idea of a vital materiality. It reveals the swarm of activity subsisting below and within formed bodies and recalcitrant things, a vitality obscured by our conceptual habit of dividing the world into inorganic matter and organic life' (Bennett, 2011:50).

Bennett also emphasises that assemblages always operate in complex ways:

Here casualty is more emergent than efficient, more fractal than linear. Instead of an effect obedient to a determinant, one finds circuits in which effect and cause alternate position and rebound on each other (Bennett, 2011:33).<sup>74</sup>

To me, this conception is useful in understanding an exhibition like *Slantways*, in which each artwork is a response either to the collection as a whole, or to an individual part of that collection. Further, I engaged with these artefacts in a way designed best to allow them to have impacts related to their own lives as things, rather than instrumentally in the pursuit of my own (potentially only tangentially related) creative vision as artist. In addition, this approach does not end at the exhibition — the artworks themselves are understood as part of the larger assemblage. They too have agentic capacity extending forwards to the audience they are viewed by, but also backwards to the archival things, to the degree that they can change perceptions about those things.<sup>75</sup>

### **Contextualising *Slantways***

Before embarking on a detailed discussion of *Slantways* and the body of work I exhibited on it, in the following chapter, to provide a broad context for these responses, I discuss the work of a selection of the many contemporary artists who have engaged with archival subject matter, both in South Africa and worldwide.

---

74 The theory of assemblages has interesting similarities to the Buddhist teaching of dependant arising or Pratītyasamutpāda, encapsulated in the words ‘This being, that becomes.’ In this teaching, all states, events and things are understood as always being the product of a complex network of temporally and spatially diverse conditions that have interacted in complex ways. See Windhorse, 2013.

75 I explore this idea in greater depth in Chapter Four.

# CHAPTER THREE

## An overview of artists working with the archive

### The archival turn

The advent of the archival turn in the late 20<sup>th</sup> Century<sup>76</sup> powerfully impacted on contemporary art practice across the globe.<sup>77</sup> According to Tom Holert, the influence of what is known, following Foster, as ‘the archival impulse’ has been so great that ‘... the ontological status of both the archive and art has been challenged, if not transmuted’ (Holert in Danbolt & Spieker, 2014:5). However, the fact that Holert immediately qualifies this generalization with the rider that, ‘Archives are distinct from artistic practices, and the ways they interact and depend on each other vary endlessly’ (Holert in Danbolt & Spieker, 2014:4), serves to underscore the breadth and density of the discursive and material terrain under consideration.

Underlying these seemingly limitless permutations in the scope of possible and actual creative engagements with the archive are the indefinite limits of ‘the archive’ itself as a conceptual rubric (Hamilton & Skotnes, 2014:4). Though the term ‘archive’ is traditionally used to denote a specifically-located physical edifice complete with a particular institutional context, material contents, focus, approach and bias, the notion of ‘archive’ is also frequently

---

76 This is not to suggest that the late 20<sup>th</sup> Century is understood as the first time in the history of art production that artists engaged with the archive as a site of practice, but rather that this period saw a more concerted and widespread engagement. For De Jong and Harney, the Dadaists’ interest in cutting up printed images from popular media was the first 20<sup>th</sup> century turn to the archive (2015:1).

77 In one estimation, the multiple factors that led to the rise of archival art include, but are not limited to, ‘fin-de-siecle/millennial nostalgia, the cultural anxieties of postmodern time-space compression, the emergence of an evidentiary aesthetic in the information age, or the expansion of visual culture, in both social and institutional life’ (Simon, 2002:102). De Jong and Harney point out that while artists’ turn to the archive has often been attributed to the 1995 publication of Jacques Derrida’s *Archive Fever*, the publication of Michel Foucault’s *Archaeology of Knowledge* in 1972 had a great impact on academic and artistic enquiry into the archive. They explain that, ‘For Foucault, the archive consists of the unspoken rules that determine “what we can say” and how we can say it. Abstract as this idea may be, it defines the archive as an object of analysis that is both within and outside ourselves: “it is that which, outside ourselves, delimits us” (Foucault 1972:147)’ (De Jong & Harney, 2015:1).

applied so freely and inclusively that it refers to an apparently unbounded entity, 'situated both within and without archival institution' (De Jong & Harney, 2015:4). Partially as a result of this lack of specificity,<sup>78</sup> and also in keeping with the open-ended character of contemporary art since the advent of postmodernism,<sup>79</sup> art that appropriates, interrogates, documents, restages, transforms or otherwise responds to the archive is characterised by a '... wild diversity of formal-discursive responses across the entire spectrum of contemporary art practices' (Holert in Danbolt & Spieker, 2014:5). So, to give only one example, both Christian Boltanski's *Les Archives du Coeur*, and George Tobias's *Blue Cupboard* may be considered as archival in nature; yet the first, consisting of a massive collection of human heartbeats recorded around the world, is universal in scope and in resonance,<sup>80</sup> while the second, consisting of a small cupboard crammed full of around 200 visual journals and diaries dating back to the artist's childhood in the 1960s,<sup>81</sup> is by contrast extremely personal, speaking of the unfolding daily life experiences of one individual only.

As even these two examples make clear, the infinite permutations in the forms taken by art that relates to the archive are matched by an equally limitless variety in the source material. Artists' archival starting points range from the '... familiar ... archives of mass culture, to ensure a legibility that can then be disturbed or detourné; but ... can also be obscure, retrieved in a gesture of alternative knowledge or counter-memory'<sup>82</sup> (Foster, 2004:4). In other words, almost any form of archival, institutional or personally constituted collection can, and has, been used by artists engaging with the archive.

---

78 See Guasch (2011) for an attempt to narrow down the term 'archive' in relation to art production, by focusing on Freudian psychoanalysis, as well as the literary techniques of Walter Benjamin and the techniques of Dadaist collage and photomontage.

79 For Simon, the archival turn is in fact an aspect of post-modern art practice. She notes that 'Insofar as ... [it] ... typically involves the movement of visual materials from extra-artistic contexts into the field of art, the phenomenon can also be interpreted as a late-stage manifestation of postmodernist appropriational practices; the turning inside-out of the institutions of modernism, if you will' (Simon, 2002:121).

80 The heartbeats, numbering more than 35 000 in 2011, were featured in *Personnes* in Paris and at the Serpentine Gallery in London in 2010 (Phaidon, n.d.). They are also archived on a small island off the coast of Japan (Searle, 2010).

81 *Blue Cupboard*, shown on the exhibition *Dada South* at the South African National Gallery in 2010.

82 It is art that utilises or responds to this second, more obscure type of archive or archival material that Foster deals with in this influential article.

So, for example, texts, records<sup>83</sup> and photographs<sup>84</sup> taken from traditional archives have been directly used as the basis for artwork, as have the artefacts customarily curated within museum contexts. In some cases, artists create and curate their own archives, sometimes based on material collected from flea markets, second-hand shops or other areas associated less with formal collections of artefacts than with their exchange and circulation. In recent years, the vast archive of the Internet has opened up a truly rich and endless source of material that is currently in the process of transforming both how material is accessed and how archive is conceptualised.<sup>85</sup>

## The critical archive

In the face of the boundless permutations on many levels discussed above, Danbolt and Spieker's *Roundtable on the Critical Archive* (2014) provides a valuable frame for focusing the analysis of archival art, by proposing the concept of 'the critical archive' within art production. They suggest that such an archive may

... enable or prepare an informed judgment that may ... become the basis for deliberate action or intervention; ... [or] ... the critical archive may point to a

---

83 As in Philip Miller's multi-media 2007 work *REwind: A cantata for voice, tape and testimony* in which extracts from records of the Truth and Reconciliation Commission that began in 1995 are inserted into Miller's performed songs, accompanied by Gerhardt Marx's projections of animated text and photographs (Miller, 2007).

84 Examples are American photographer Ayana V. Jackson's *Archival Impulse*, in which she performatively engages with colonial era photographs (Jackson, 2013), taken in the global south as well as at the human zoos that toured Europe (Jackson, 2014). Local examples include Nomsa Makhuba's *Self-portrait series*, discussed in relation accessed to my own work in Chapter Four and Andrew Putter's *Native Work* (2014), 38 portraits constituting a contemporary re-imagining of Alfred Duggan Cronin's ethnographic photographs, in an effort 'to provoke another way of reading these images, using them as the basis for making new work motivated by the desire for social connection, a desire which emerges as a particular kind of historical possibility in the aftermath of apartheid' (Putter, 2012).

85 One uncomplicated example is Ryan Trecartin's 2010 work *Web 1.0: A Lossless Fall*. However, it has been widely acknowledged that the impact of the digital age goes far further than individual artists' mining of the Internet for source material. As an infinite electronic archive, the Internet '... is characterized by a continuous flow of data ... without geography and without time restrictions, with the subsequent displacement of the notion of storage, classification and retrieval of information, to navigation and to the hyperlinks that connect the pieces of information' (Guasch, 2011). The implication is that source and artwork become so intertwined as to be inseparable, as witnessed by the array of digitally-based exhibitions devoted to human rights abuses in the countries of Southern Latin America, which 'configure a performative system ... a mediated bios ... [allowing for] ... the exchange between communities and documents, generating new forms of life that are mediated by reproductions, transfers, and even documentary modifications that visitors can put into effect' (Gómez-Moya in Danbolt & Spieker, 2014:20).

moment of crisis, an impasse, or a calamity that can be located either in history ... or, crucially, in the archive itself (Danbolt and Spieker, 2014:3).

For these authors, it is the latter half of their conception of the 'critical archive' — the '... moment of archival (self-) critique' in which the authority of the archive itself is placed under scrutiny that lies at the heart of many contemporary archivally-based artworks' (Danbolt & Spieker, 2014:3-4).

This 'moment' is certainly relevant to much archival art — as De Jong and Harney point out, for African artists engaging with the archive, it is synonymous with the intention '... to question how colonial knowledge has been produced, accumulated, and circulated ...' often prefiguring 'acts of epistemic recovery' that allow for the retrieval of forgotten or excluded histories (De Jong & Harney, 2015:1).

However, both parts of this conception seem relevant, to the extent that many archivally-based or inspired artworks draw on archival material specifically to expose the socio-political complexities and/or inequities and injustices of past historical eras in a particular national history, so that they themselves constitute an intervention or even exposé.

A comprehensive example is provided by Jasmin Cibic's immersive installation, *For our economy and culture*, in which the artist covered an entire pavilion at the 55<sup>th</sup> Venice Biennale with wallpaper bearing different artists' impressions of an indigenous Slovene beetle now disavowed because it was named after Hitler, and showed two video recreations of events from the country's totalitarian history, as well as flower paintings from the art collection of the Slovenian National Assembly (Brady, 2015).

A comparable local example is Pippa Skotnes's *Miscast*, in which, together with texts and images documenting the ruthless oppression, enslavement and genocide of the Bushmen people under colonialism, the artist exhibited the body casts that had been used to create the dioramas of Bushmen in the South African Natural History Museum. In so doing, she laid bare the unexamined practices of display that had for so long prevailed in the South African National Museum. Both Cibic and Skotnes' work expose the reality that the 'calamity' referred to by Danbolt and Spieker can be located both in history and in the archiving of that history.

For Foster, the fairly widely-used strategy of reproducing the physical

form(s) and/or practices of the traditional archive ‘underscores the nature of all archival materials as found yet constructed, factual yet fictive, public yet private’ (Foster, 2004:5). Here again, there are differing aspects of archive that artists may wish to emphasise or investigate: as Holert points out, the contemporary conception of archive tends to oscillate between two foci: ‘... its fetishistic embrace as a mystifying container of archaeological splendour ... and its theorization as the quintessential matrix of power-knowledge ...’ (Holert in Danbolt & Spieker, 2014:4). According to Vierke, in his performative interventions in the video archives at Bayreuth University, the Kenyan artist Sam Hopkins explicitly refers to both ‘... the institutional processes and intellectual mechanisms at work in the making of an archive ...’ Via this intervention, Hopkins enables a new reading of archive, one amounting to ‘an ordered set of practices with rules but in the absence of hegemonic power’ (De Jong & Harney, 2015:4).

An example from the 1990s of the creation of a new archive assembled according to a rhizomatic logic reminiscent of archival collections, yet one that is also deeply idiosyncratic, is Renée Green’s *Partially Buried in Three Parts (1995–1997)*, in which material relating to the artist’s own life story, as well as to conceptual artist Robert Smithson’s 1970 installation, *Partially Buried Woodshed*,<sup>86</sup> was reconfigured to create an archive-like multimedia installation. An agglomeration of video, photographs, newspaper articles, rock fragments, books and other cultural artefacts were combined to examine and comment upon diverse cultural and political events and phenomena, such as the student protests at Kent State University in 1970 and the experience of German immigrants in America (Whitebread, 2009).

Another example of a custom-made archive is the oeuvre of *The Atlas Group* (Walid Ra’ad) in which both found and compiled notebooks, photographs, films and videos dealing with various aspects of Lebanese history, most particularly the civil war of 1975–1990, have been assembled and exhibited (The Atlas Group, n.d). In relation to this work, Ra’ad emphasises a fluid and open-ended approach to the history he engages with:

We proceed ... from the hypothesis that “The Lebanese Civil War” is not a self-

---

86 See Mundy (2012) for a discussion of this artwork and the metaphorical significance it assumed after the Kent State shootings of 1970.

evident episode, an inert fact of nature. This war is not constituted by a unified and coherent object situated in the world. On the contrary, for us “The Lebanese Civil War” is constituted by and through various actions, situations, people and accounts, some of which are manifest in the documents we presented. (The Atlas Group, *Let’s Be Honest, the Rain Helped, 2003* in Mereweather, 2006:179).

Both Santu Mofokeng’s *The Black Photo Album / Look at Me: 1890–1950* and Zanele Muholi’s *Faces and Places* (2011–) provide powerful South African examples of work that, through its challenge to persistent long-term erasures and consequent lacunae in the archive, can be considered as counter-archival in nature.

Mofokeng’s black-and-white photographic portraits commissioned by black working and middle class South Africans from 1890 to 1950 are shown either as prints or as slide show video projections (Mofokeng, n.d.). In both cases, the images are interspersed with text in which Mofokeng questions the identity of the subjects of the photographs, expressing sentiments such as, ‘Who are these people?’ and ‘What were their aspirations? What is going to happen to those aspirations at the end of twentieth-century South Africa?’ (Dodd, 2014:158). In Dodd’s reading of this work,

Multiple temporalities converge when the records of the original sittings (represented by the faded original prints) jostle with the contemporary vision of an artist interrogating the meaning of his forebears’ photographic experience ... giving contemporary viewers an inkling of the complex allegiances they were negotiating through their everyday life choices (Dodd, 2014:157).

Similarly, but this time referring to our contemporary context and to exclusion from the archive on the basis of the intersecting identity markers of race and gender orientation, *Faces and Phases*, Muholi’s photographic portraits of black lesbian and gay South Africans, as a newly-created collection constitutes an archive that for the first time makes nationally and internationally visible a subculture and subjectivity that disavowal and discrimination have kept hidden, unrecorded and excluded from the archives.<sup>87</sup>

---

87 It is fascinating to contrast Muholi’s work with Tony Just’s documented performance in a public toilet known as the site of multiple gay sexual encounters. The performance focused on scrubbing the space clean, an act of ‘eliminating traces ... [that] ... is, at the same time, a visualizing practice’ (Boudry and Lourenz in Danbolt and Spieker, 2014:17). Also see ‘Ephemera as Evidence: Introductory Notes to Queer

Thomas Hirschhorn's monuments to the philosophers Baruch Spinoza, Gilles Deleuze, Georges Bataille and Antonio Gramsci, produced over a period of 14 years, and installed in working class neighbourhoods in Europe and America,<sup>88</sup> provide examples of a less nationally bound yet still innately political form of intervention (Artspace, 2014).

Hirschhorn's choice of location for the monuments' exhibition underscores the point that archives produced by artists,

... deploy the archive and its practices ... in plain view. In this way, not only do such practices aim to recognize the archive as a place of (knowledge) production rather than a place of passive consignment, they also variously invite us to participate in the archive's evolving configuration (Danbolt & Spieker, 2014:3).

Newly constituted archives<sup>89</sup> made up of diverse and idiosyncratic artefact collections also feature prominently in archival art (Artspace, 2014).

One example is Francis Alys's curated collection of 300 renditions of Saint Fabiola,<sup>90</sup> found at markets and junk shops around the world over a 15-year period. The portraits, executed in many different media, are all amateur versions of a lost painting by Jean-Jaques Henner, shown in the Paris salon in 1885. Their provenance as popular art reveals '... in microcosm why works of art come to be made, how art is seen and received ... by ordinary people ... and how a single work of art lives on, constantly evolving in a never-ending, open-ended process' (Dorment, 2009). Their curation into a collection and exhibition in renowned art institutions of Europe and Britain takes this process of renewal and change one step further.

Another example of a creative intervention based on a collection of things, this time already wholly assembled when one of the artists first encountered it, is Oliver Croy and Oliver Elser's installation, *The 387 houses of Peter Fritz*, a collection of model buildings constituting a '... near-encyclopedic inventory of all manner of provincial architectural styles, from farmhouses to bank buildings, churches to traditional single family homes, villas to gas stations', and built out of everyday materials by Austrian insurance clerk and outsider artist Peter Fritz

---

Acts' (Muñoz, 1996).

88 Produced in Amsterdam in 1999, in Avignon in 2000, in Kassel in 2002 and in New York in 2013 respectively

89 In other words, archives deemed to be archives by the artists who have created them.

90 Exhibited at the National Gallery, London in 2009 (Lucarelli, 2012).

(Designboom, 2013).<sup>91</sup>

Over the course of her career, South African artist Penny Siopis' has amassed, used and re-used a vast collection of artefacts in her installations. Siopis considers the materiality as a significant aspect of her work, whether it takes the form of painting or of installation. In the exhibition *Sympathetic Magic*, for example, the first work visitors encountered on entering the exhibition was Siopis's renowned 1989 history painting, *Melancholia*, suspended from the ceiling in such a way that both its front and its back were visible — in other words, its quality as a thing was forcefully exposed. On moving further into the space, viewers were confronted by a mass of things attached to a dome-shaped structure covering the stairwell to the lower floor. Kearney points out that

Through first foregrounding the material reality of the painting as a painted surface, and then confronting the viewer with an environment made of many things that could be understood as a physical manifestation of the pile of things in *Melancholia*, in this exhibition the artist plays with the relationship of representations of things and using real things as a means of representation (Kearney, 2013:53).

The work *Will* (1997–) also formed a part of this exhibition (and subsequently of several others). It consists of a sizeable collection of eclectic artefacts, ranging from religious icons to battered antique toys, and from a tin plate commemorating Mandela's release from apartheid prison to items of clothing belonging to her grandmother,<sup>92</sup> all assembled by or given as gifts to the artist over the course of her lifetime. In terms of the arrangement of this collection, Siopis comments that, 'There is a kind of order which I regard as a raw side of the language of my installations, a language which creates a dialectic between directedness and contingency, or between structure and randomness' (Mbembe, 2005:120).

---

91 Exhibited on *The Encyclopedic Palace* on the 55<sup>th</sup> Venice Biennale, 2013 (Designboom, 2013).

92 For Jennifer Law, each of these artefacts is an historical fetish, '... that object which is both empowered by its association with an originary moment of trauma, and simultaneously shackled to that history as representative of some fundamental truth ... such an object thus embodies the ability to transform the detritus of history, the abject, into a thing of power' (Law, 2002:10). She goes on to explain that the historical fetish embodies the tension '... between (spatial) ambiguity and (temporal) fixity, between stasis and motion, animism and inanimism' (Law, 2002:10).

In *Will*, Siopis undermines the conception of ‘archive/collection’ as a stable entity formed to safeguard the artefacts of the past into perpetuity by making known the existence of a will, in which each of the artefacts on display has been bequeathed to an undisclosed recipient. On the one hand, there is thus a public acknowledgement of the inevitable dissolution of the collection; but on the other, because the things are part of an artwork that has been repeatedly exhibited,

... each object ... is subject to eternal return. Nothing is wasted or relegated perpetually to the shelf. Nothing dies. Each object, rather, is kept in a constant state of circulation, moving from one installation to another, ever becoming something else (Law, 2002:10).

Kan Xuan’s *Millet Mounds*, a 174 — channel bank of stop-motion colour videos in a sense presents the documentation or cataloguing of a ‘collection’ of a different order — the 174 ancient imperial burial mounds still in existence across China. In its cataloguing of these ancient monuments, the work reflects on the ongoing temporal entanglement of the past and present in China (Ullens Center for Contemporary Art, 2012).

Finally, Tammy Rae Carland’s *An Archive of Feelings* (2008),<sup>93</sup> presents a photographic counter-archive, constituted by a series of photographs documenting idiosyncratic artefacts that for the artist embody particular emotions and experiences — a set of mixed cassette tapes with hand-drawn covers, a box of letters tied with a ribbon, a worn copy of an iconic feminist book, and various domestic ephemera, such as two heart-shaped chocolate boxes, and a red checked mug. The focus on these artefacts insistently emphasises their power to carry emotions such as desire and mourning, and as such presents an interesting take on the agency of things. According to Cvetkovich, ‘The term “archive of feelings” puts pressure on traditional notions of the archive, because emotional experiences and intimacies are frequently ephemeral, and hence not always accessible via the print records and other documents conventionally found in institutionally-based archives’ (Cvetkovich, A. 2012).

---

93 Named for Ann Cvetkovich’s book of the same name.

## The curation of institutional collections

Artists who work with object collections held in institutions such as museums and universities often choose to focus on curation, or more strictly speaking, re-curation. Working in this fashion allows for an invaluable conceptual freedom: since their ‘... groupings and juxtapositions are not restricted or regulated by historical conventions and formal museological ordering systems ... [artists can] ... offer fresh insights beyond scholarly interpretations’ (Putnam, 2012).

There are many instances where institutional collections have been re-staged and new taxonomies developed to complicate categories or overturn them altogether, in the process exposing hidden, but substantial, ideological biases and exclusions. One influential example is Fred Wilson’s 1992 re-curation of the permanent displays in the Maryland Historical Society, *Mining the Museum*, which used a range of creative strategies to critically expose the extent of partiality and racial exclusion pertaining in the institution’s construction of the history of Maryland.<sup>94</sup>

*Metalwork 1793–1980* provides a potent example of Wilson’s disturbance of categories and their effect. As a means to emphasise the slave foundations upon which the luxurious lifestyle of the 19<sup>th</sup> Century Baltimore elite was based, the artist chose to juxtapose elements usually kept entirely separate — a pair of slave shackles (Ginsberg, 2012), with artefacts conceived of as arts and craft, 19th century repoussé style silver pitchers, flacons and teacups (Putnam, 2012). Another forceful example is provided by the work *Collection of numbers*, in which a selection of arrowheads, each with its accession number painted onto its surface, was displayed together with the label *Collection of Numbers*. By naming the work for the accession numbers rather than the artefacts they reference, Wilson underscores how ‘The museum’s compulsion to amass objects, privileging their collecting, cataloguing, and classifying, says far more about the pathology and value systems of the curators than about native communities’ (Corrin, 1994:14).

Mark Dion, too, has re-curated numerous collections in both universities and museums. Two examples of his interventions in the context of university collections are provided by his work at the Wexner Center for the Arts at Ohio

---

94 See *Mining the Museum: An Installation by Fred Wilson* (Corrin, 1994).

State University in Columbus in 1997, and four years later at the Weisman Art Museum at the University of Minnesota, Minneapolis. For these interventions, Dion used the university object collections as the material for modern-day cabinets of curiosity, in which he displayed natural history specimens, scientific instruments and cultural artefacts (Putnam, 2001:74). Though in concept and structure these two exhibitions were similar, they were also ‘... markedly different in design, contents, and organizing processes, revealing the deep histories and contemporary practices of their respective universities ...’ (Sheehy, 2006:xii).

Dion’s work is always subtly subversive: in his selection and classification of the material he chooses to display, he ‘utilizes the methods of science and museums, foregrounding these activities as part of his work, but he also suggests the contingency of these systems of knowledge by employing alternate and unexpected display techniques’ (Sheehy, 2006:8).

At UCT itself, the 2004 exhibition *Curiosity CLXXV* featured things sourced from across the university, ranging from artefacts that formed part of teaching collections to miscellaneous material found forgotten and neglected at the bottom of drawers and the back of cupboards (Skotnes, Langerman, and van Embden, 2004).<sup>95</sup> In the case of this project, the main intention was ‘to subject the process of collecting and exhibiting to scrutiny and to force collections of objects from different disciplines into dialogue with each other’ (Centre for Curating the Archive, 2015). In other words, in its foregrounding of the artefacts themselves and consequent disruption of taxonomies, this exhibition challenged conventional discipline-bound readings of these things.

Cornelia Parker’s 1995 exhibition *The Maybe* also worked with the curation of museum artefacts, though in this case the things were removed from their institutional homes within various British museums and displayed in the Serpentine Gallery, London. In this work, a range of artefacts associated with historical celebrities — from Turner’s watercolour box and the last pen Dickens used to one of Churchill’s half-smoked cigars — were displayed in a series of identical vitrines in the various rooms of the gallery (Gale, 1995). In the final vitrine, in the central gallery space, the actress Tilda Swinton lay sleeping

---

95 This exhibition also included some of the Manuscripts and Archives collection material that I worked with for my own project.

(Putnam, 2001:147).

For Parker, the juxtapositions she made use of in her imposed taxonomies were important mechanisms in drawing visitors' attention to the artefacts' own narratives as well as to the way they resonated in combination:

By placing Queen Victoria's stocking next to Wesley's spurs, you could imagine the darned hole having been made by the spur. Faraday's spark apparatus placed beside Babbage's brain hints at a Frankenstein monster. I liked playing around with these little histories. I wanted to breathe new life into these objects by their juxtaposition and their relation to Tilda, living and breathing only a few inches away. I was interested in an orchestration of objects, in the sense that each object is itself, its own sound, but that all the objects together create something larger than the sum of the parts (Parker in Tickner, 2003:384).

In her 1999 intervention *Appointment* at the Freud Museum in London, Sophie Calle inserted a combination of photographs, texts and artefacts from her personal archive into the renowned house-museum, still furnished with Freud's furniture, household effects and antiquarian object collection. According to James Putnam,

Her references to certain highly significant, objects and emotionally charged events in her life have many parallels to Freud's own psychoanalytical theories and his collecting passion (Putnam, 1999).

More recently, curation also featured in an interesting way in Grayson Perry's *Tomb of the Unknown Ceramicist* at the British Museum. Though he had previously curated two exhibitions inspired by Victorian social history and Twentieth-century art,<sup>96</sup> for the 2011 show he decided to work in a counter-intuitive manner to invert his (and other artists') process:

Why not I thought, make the works I am inspired to create, and find objects in this vast collection that respond to them? Somewhere in its endless storerooms there must be objects that echo my concerns and style. I have spent my entire career under the influence of the past. I wondered what I would learn from reversing the process (2011:11).

---

96 *The Charms of Lincolnshire* (2001) and *Unpopular Culture* (2008 )

In choosing the artefacts he displayed for this massive installation, Perry was guided by the relationships they bore both to each other and to his work. He explains that ‘Sometimes the connection is in their function, sometimes in their subject and often in their form. One thing that connects all my choices is my delight in them’ (2011:11).

## The future-entailing archive

The logical outcome of the second aspect of Danbolt and Spieker’s conception of the ‘critical archive’ — namely its ability to ‘point to a moment of crisis, an impasse, or a calamity that can be located ... crucially, *in the archive itself*’ (Danbolt & Spieker, 2014:3 my emphasis) is that artists direct their energies towards ‘the nonreifying opening and liquidation of archives, turning them from rigidly organized storing spaces into future-entailing processes’ (Holert in Danbolt & Spieker, 2014:5). Arguably, many, or even most of the works discussed above do this, or go some way towards this outcome. One final example of an archival artwork that for me perfectly exemplifies this transformative and forward-looking quality or intention is Tue Greenfort’s *The Wordly House*.<sup>97</sup> In a small, neglected wooden structure, a birdhouse located on a bridge over a fish-filled canal in Kassel’s Karlsaue Park, Greenfort created a multi-media archive relating to philosopher Donna Haraway’s work on interspecies co-evolution. As Amelia Barikin points out,

... The *Wordly House* blocks the idea of the archive as a closed repository or registry through its explicit engagement with the contingencies of site. Circled by birds above and navigated unknowingly by fish below, the human-made contents of the building enter into a strange dialogue with their earthly and nonhuman surrounds, a dialogue that suggests equivalences of value between the content of the records stored within (art, philosophy, text) and their worldly actualizations without (trees, sky, water, grass) (Barikin, in Danbolt & Spieker, 2014:18).

---

97 Exhibited on *Documenta* (13) in 2012.

## Points of intersection

Creative influences are far from unilinear, and there is no guarantee that an artist choosing to work with archival material will be influenced by others who have chosen to do the same. None of my own responses to the archive in the body of work I produced for *my PhD project* took exactly the same forms as the examples described above. However, there are distinct influences and overlaps — some occurring in terms of working with the materiality of things and collections of things, others in the choice of somewhat idiosyncratic, atypical or marginalised archival source material. Still other overlaps occur in the aim to challenge the epistemological framing of a particular archive (be this on a large or more modest scale), and/or in working with institutional collections in various ways. Importantly, there are many commonalities in the effort to explore the long reach of history into the contemporary moment.

In Chapter Four, I will discuss my own conceptual concerns and considerations, creative processes and the resultant body of work I produced in response to the Manuscripts and Archives object collection for my exhibition, *Slantways*.

# CHAPTER FOUR

## *Slantways*, September 2014

In attempting this account of the creative component of my PhD project, I am mindful of Michael Ann Holly's observation that writing about art is 'the act of trying to put into words, spoken or written, something that never promised the possibility of translation' (Holly 2007:7). In the pages that follow, I discuss my conceptual concerns, the exhibition as a whole and each of the artworks that together make up the body of work that was exhibited on *Slantways* in 2014, all the while cognisant of the fact that I am writing about an event that ideally is experienced in very different ways from those allowed for by the written word.

I introduce the discussion by considering some of my thinking and strategies in terms of the exhibition. I then consider my choice of venue for the exhibition, the Centre for African Studies (CAS) Gallery. This section is followed by a discussion of each of the artworks on the exhibition. I begin with *Finding Aid: the archive partially seen*, the work that deals directly with my visual impairment and its consequences for the project as a whole. I then discuss the only work that refers to the entire collection, *Hoard*, including all three of its iterations — firstly at the interim postgraduate exhibition *Imperfect Librarian*, held at Michaelis Gallery in March 2012, later on *Imaginary Fact: South African Artists and the archive*, at the South African Pavilion on the 55<sup>th</sup> Venice Biennale in 2013, and finally on my PhD exhibition *Slantways*.

Next, I consider the artworks that I made in response to particular elements of the object collection individually.<sup>98</sup> Before I discuss each of these artworks, I present a biographical essay on the archival thing that it responds to. As I mentioned in the methodology section, for the purposes of this project, I consider this biographical approach as only one of a series of strategies I employ in responding to these things; and as I emphasise below, it was my

---

98 The exception here is *Homage to Mr Immelman*, which speaks of the person responsible for the entire collection. However, because I made them at the same time and for ease of reading, I am including the discussion of this work together with that of the two other performative pictures, *Troublesome Ancestors I and II*.

conscious intention to embrace the disorderliness that often characterises an unfolding creative process rather than avoid it. Thus I make no claim for uncomplicated continuity in terms of these cultural biographies: in the case of some of the artefacts, for example in that of the plastic hairbrush, the cloth associated with Olive Schreiner and the Rhodes 'deathmask', the trajectory from biographical description to artwork is direct. In other cases, though, for example with the puzzle 'The New Game of HUMAN LIFE' and the chip of wood, the response to the artefact presented by the artwork is oblique or even surprising when the biography is taken into account.

Lastly, I turn my attention to the small satellite exhibition of a selection of things from the object collection, held in the foyer of Special Collections in the J. W. Jagger Library to coincide with *Slantways*.

## **A set of creative strategies**

I began this project with the conviction that I was not interested in 'cut and dried' creative solutions, resulting in a neatly coherent and contained exhibition, but instead aspired to a sense of open-endedness in terms of my ultimate body of work.<sup>99</sup> Associated with this intention was the desire to make use of as many different media and processes as time, my budget and my abilities would allow. For me, this approach felt important to the extent that giving an audience access to artwork realised through a variety of media and taking a range of forms allows the collection to be apprehended from a whole range of different angles. This approach seemed also to resonate with Immelman's free-spiritedness as a collector and the consequent lack of taxonomy in the collection.

However, the desire to pursue a broad and for me, experimental range of creative processes<sup>100</sup> became even more urgent with the onset of my

---

99 In the early stages of the project, before I had conceived of a slantways approach as the primary theoretical key to the work I was producing, I was attracted to the idea of trying to produce a body of work inspired more by the concept of the rhizome, which '... connects any point to any other point ... [with] ... neither beginning nor end, but always a middle (milieu) from which it grows and which it overflows ... The rhizome operates by variation, expansion, conquest, capture, offshoots' (Deleuze & Guattari, 1987:23). This seemed to me to speak to the nature of the archive itself, obstinate and in some way uncontrollable despite all the evidence of multiple technologies of control put in place to attempt to contain it.

100 I had never previously worked in video, sound, smell or performance, and had also never attempted to sculpt or produce a shadow piece.

impairment: the condition of deteriorating sight discourages hesitation, instead demanding a determination to use the time and resources available as well as possible to the extent that the impairment allows.

After exhibiting selected artefacts from the Manuscripts and Archives object collection on the interim postgraduate exhibition *Imperfect Librarian* in April 2012 (see discussion of *Hoard* below), I made a further important decision regarding the body of work I wished to show. Rather than again curating the artefacts themselves as part of my final exhibition, I decided to omit them from the exhibition and instead to display them on a satellite exhibition, held concurrently with *Slantways* in the foyer of Special Collections in the J. W. Jagger Library (see below). This amounted to a choice to focus on creative responses in the form of a set of artworks — a strategy I considered as having a stronger potential to challenge the audience to engage with the object collection from different perspectives, without falling back into easy, familiar forms of experiencing the things.

However, although the things I was responding to were not physically present within the exhibition, I utilised various strategies to ensure that they did not disappear from view to those engaging with the artworks. Firstly, a wall text related each artwork back to the original archival thing it responded to by



outlining its provenance — the plastic hairbrush, the Rhodes mask, the record, the chip of wood, the addressed cloth, the miniature microscope and the puzzle ‘The New Game of HUMAN LIFE’.

Then, in the case of *Hoard*, the centrepiece of the exhibition, a prominent set of explanatory textual descriptions of each thing (see Appendix 2); together with a photograph performed the same function. This referring back to the artefacts was designed to add resonance to the work, since whatever form my creative response took, the reminder of the material form and the story of the thing that had inspired it persistently tied it to that artefact.

### **Understanding ‘*Slantways*’ as a set of assemblages**

As the project proceeded, my concern with issues of the archival things’ actancy, particularly in terms of their effect on me as an artist producing artwork in response to them, came to the fore. As discussed in Chapter Two, for me, the artefacts’ materiality was a vital feature in this regard. However, late in the project, inspired by Bennett’s conception of assemblages as a vehicle for the expression of an ontologically varied actancy, I also began to interrogate the (for me new) conception of my exhibition as an overarching assemblage, made up of a series of smaller assemblages.

The advantage of this conception is that, in keeping with the concern mentioned above — the desire not to allow the archival things and their stories to slip out of view in visitors’ experiences of the artworks — it acknowledges their role as active participants in the process of putting together the exhibition, rather than obliterating it and focusing solely on my own as artist.

Importantly, for Bennett ‘... process ... [is] ... itself in possession of degrees of agentic capacity’ (2010:33). Bearing this inclusion in mind, I understand the creative process as an aspect of each assemblage, with its own sometimes unpredictable part to play in influencing the final body of work. This sense of process for me incorporates my own effort to be open to the range of the information the things offered me, as well as to the exciting, though sometimes unpredictable, effects of the materials I used to make the artwork. I will discuss how this concept of assemblage plays out in relation to one chosen artwork, *Hoard*, the centre piece of the exhibition, in the section discussing that work below.

## Referencing trouble: choosing to exhibit in the Centre for African Studies (CAS) Gallery

Kearney notes that for Bal (2002:137), ‘... framing in an exhibition is a form of intervention on the part of the critic, scholar, curator or artist that draws the viewers’ attention to looking at objects and artworks in a particular way’ (Kearney, 2013:51). The first step and an integral part of this process is the choice of physical context for the artworks in the form of gallery or exhibition space. In terms of my own choice of the CAS Gallery as the venue for my exhibition *Slantways*, the most pressing motivation was provided by the conceptual concerns of the work to be displayed.

To exhibit anywhere on UCT Campus was to hope, in a modest way, that my own creative work could add a new layer to the institutional history to which it was trying to respond. However, the specific placement of the exhibition at the CAS gallery went one step further. According to the Centre for African Studies website, this is a ‘... a multi-use space which hosts a regular programme of exhibitions, film screenings, seminars, workshops and conferences ... [and is] ... [c]onceptualized as a site of public engagement, and as a site of learning ...’ (Centre for African Studies, 2015a). This is all well and good. However, if the history of the Centre for African Studies is taken into account, the physical space of the School’s gallery is also inseparable from a highly charged discursive space, within which the ideological stance and methodological approaches, as well as the consequent political relevance of African Studies at UCT have all been and continue to be subject to much ongoing debate and critique. By choosing to insert the creative efforts I had made to unsettle the archive into this gallery, I could not but add my own artwork into that continuing debate.

Ntsebeza states unequivocally that the ‘... genealogy of the concept of African Studies at UCT cannot be divorced from the colonial strategy of ruling over the indigenous people’ (2012:4). The first version of this school, the School of African Life and Languages, was established in 1920, after much lobbying by the missionary W.A. Norton, who argued that its existence would ensure the development of policy appropriate to deal with ‘the Native problem’ (Ntsebeza,

2012:3).<sup>101</sup> In 1933, the name was changed to the 'School of African Studies.'<sup>102</sup>

Norton's emphasis on the potential for such a school to collude actively with government became a reality once the school was established, most notably in the focus of Radcliffe-Brown's early research, '... geared towards demonstrating the practical utility of the School — with its focus on African life — to policy-makers and administrators' (Phillip, 1993:24 quoted in Shoro, 2014:31). Such collusion continued to feature, albeit unevenly, into the apartheid period, for example in the academic Gerard Lestrade's willing collaboration in the development of the Bantu Education curriculum in the 1950s. At the same time, after the passing of the extension of Universities Act in 1959, segregation was extended into tertiary education, and the apartheid government's subsequent intensification of pressure to uphold these policies caused ongoing tension between the university and the state into the 1960s.

In 1965, the government banned academic and head of African law and administration Jack Simons from teaching. Two years later, Monwabisi Archie Mafeje failed to have his appointment as senior lecturer within the Department of Social Anthropology confirmed, apparently because of interference from the apartheid government. This government interference, as well as other internal pressures<sup>103</sup> led to the weakening and ultimate closure of the School in 1973. However, ongoing interest in the area of African Studies amongst UCT staff, students and administrators led to further debate and discussion, and the Centre for African Studies opened its doors in 1976, with the greater part of its funding coming from The Harry Oppenheimer Institute<sup>104</sup> to which it was affiliated (Ntsebeza, 2012:10-11).

A continued (and inconclusive) exploration of what studying Africa at UCT entails has been a feature of the Centre for African Studies, notably from the late 1980s onwards, when the collapse of the apartheid regime and its replacement by the ANC in a future democratic South Africa was imminent

---

101 From 1920 to 1925, the School was headed by Alfred Radcliffe-Brown, who also held the chair of Social Anthropology. Initially W.A. Norton held the Chair of Bantu Philology, but this position was disestablished in 1923 (Ntsebeza, 2012:4).

102 Together with social anthropology, the departments of African languages, archaeology and African law and government, later Comparative African government and Law were all associated with the School.

103 Namely, the creation of independent departments within the school, as well as the new awareness of the importance of an Afrocentric perspective within the Humanities (Van der Merwe, 1979:63 in Ntsebeza, 2012:10).

104 Harry Oppenheimer was Chancellor of UCT at this time.

(Ntsebeza, 2012:12-13). In 1997, Professor Mahmood Mamdani was appointed as Director of the Centre. Though the recognition of his potential as a strong leader able to re-connect the Centre with African intellectuals and discourse from the rest of the continent was a strong motivation for his appointment, Mamdani's subsequent outspoken and vociferous critique of African Studies at UCT served to expose and intensify ideological faultlines within the academic community. In the ensuing debates, what it means to study Africa academically, and specifically the approaches utilised in the Centre for African Studies in the interests of this undertaking were vehemently contested. These debates, intertwined with and impossible to divorce from a series of ever-simmering disputes over the lack of real transformation in the post-apartheid period within the university, have, on occasion, erupted into massive public confrontations. This occurred most notably in 1998 with the 'Mamdani affair'<sup>105</sup> and again in 2009, when the Faculty of the Humanities envisaged disestablishing the Centre for African Studies and replacing it with a new school, based on the merger of several departments.<sup>106</sup> This caused a protracted furore, particularly amongst students, who raised issues relating to lack of consultation, and further questioned the commitment on the part of the university management to UCT's transformation into an African university committed to an Afro-centric critical perspective and African forms of knowledge production (Shoro, 2014:37-40).

The CAS openly alludes to this contestation on its website, noting that, 'In quite fascinating ways, the Centre for African Studies ... has been a flashpoint in the life of the institution, generating debate, and focusing a key set of issues and debates. These debates form one of the core legacies of African Studies at UCT, and become a point of departure for our students. Part of the mission of African Studies at UCT is to use the resources of these debates, plus other similar debates in universities across the global south, to re-imagine and reconfigure an inherited architecture of knowledge' (Centre for African Studies, 2015b).

---

105 In that year, Professor Mamdani was asked by the then Deputy Dean of Humanities, Associate Professor Wannamaker, to develop the curriculum for a new multi-disciplinary humanities foundation course. His course, entitled 'Problematising Africa' was subsequently rejected by the Deputy Dean and a curriculum working group. Mamdani's critique of the course that replaced it led to a furious and widely publicised dispute, culminating in his equation of African Studies at UCT with the Bantu Studies of the past and his resignation (Shoro, 2014:32-34).

106 Ultimately, CAS was incorporated into the current School of African and Gender Studies, Anthropology and Linguistics (AXL), which was launched in 2012, the result of a merger between the African Gender Unit, the Centre for African Studies and the departments of Social Anthropology and Linguistics.

It is precisely here, at this juncture between the legacy of the university's tainted and compromised past, and the 're-imagin[ing] and reconfigure[ing] ... [of] an inherited architecture of knowledge', that I sought to locate my exhibition, *Slantways*. In this case, though, my work focuses on the archive itself and its legacy, rather than on the debates about that legacy. Furthermore, though my work relates to the UCT archive, it engages with this history in the context of the contemporary moment, in which, according to Shoro, there exists an ongoing '... questioning of whether UCT is relevant, reflective and complementary to the postcolonial African context in which it is located as well as the widespread opinion — both within and outside the university — that it is not' (Shoro, 2014:44). This summing up of the contestation surrounding the transformation of the ethos and curriculum of UCT, written in 2014, has been fully borne out by the Rhodes Must Fall campaign of 2015, the latest episode in the ongoing debate around the constituents required for the establishment a staunchly and unequivocally post-colonial university (see Conclusion).

## **The artworks**

### **Finding Aid: The archive partially seen**

Though overwhelmingly taken for granted, embodiment is central to human experience. Steven Van Wolputte, referring to the writings of Thomas Csordas on embodiment, explains that

... embodiment is about “understanding” or “making sense” in a pre-reflexive or even presymbolic, but not precultural, way (Csordas 1990:10). It precedes objectivation and representation, and is intrinsically part of our being in-the-world (Van Wolputte 2004:258).

Discussing the experience of paralympians who were not born congenitally deformed, but have suffered some form of impairment, David Howe notes that

Following Seymour, these individuals can be seen to be re-embodied. That is, 'embodiment is our life-long obsession. Eating, sleeping, washing, grooming, stimulating and entertaining our bodies dominate our lives' (Seymour, 1998:4), regardless of our state of impairment. After these individuals have relearned

basic tasks, or perhaps alongside these activities, they become in a sense re-embodied, that is they learn some of what their “new” body can and cannot do in an adaptive physical activity setting where sport will feature (Howe, 2011:280).

In other words, post-impairment, via a process of re-orientation, the athletes enter a new phase of their embodiment.

Van Wolputte cites Stephen Hugh-Jones’ (1979) and Henrietta Moore’s (1996) conception of space as the third term ‘... to mediate (or inter-articulate) social structure and individual agency’ (Van Wolputte, 2004:253). Space is understood as a bodily relationship orientating the subject culturally, historically and ideologically (Van Wolputte, 2004:254). For Terence Turner, understanding the body in this way, namely in relationship, is critical, ‘... and can be considered the material infrastructure of the production of selves, belonging and identities’ (Turner, 1994:28 in Van Wolputte, 2004:256).

Alongside agency and sexual difference, Csordas provides a ‘third dimension of embodiment, consisting of ten components of corporeality. These components are: bodily form, sensory experience, movement or motility, orientation, capacity, gender, metabolism/physiology, co-presence, affect and temporality’ (Csordas, 2011:147-148). As well as the obvious question of capacity (see below), of particular interest for my purposes in *Finding Aid* is orientation — the human inhabitation of and creation of space ‘... by the manner in which we move in relation to objects and others’ (Csordas, 2011:148). As Ahmed elaborates,

The body provides us with a perspective: the body is “here” as a point from which we begin, and from which the world unfolds, as being both more and less over there. The “here” of the body does not simply refer to the body, but to “where” the body dwells (Ahmed, 2006:8).

*Finding Aid: the archive partially seen* takes as its starting point my own bodily ‘being-in-the-world’ in the recent post-visual impairment phase of my life. As such, this work relates directly to the issue of my re-embodiment via multiple, continuing re-orientations in terms of a list of conditions that influence or even govern my ontological experience. This list includes, but is far from exhausted by, the following: the sighted state, the state of blindness and

multiple indeterminate and constantly fluctuating in-between degrees of seeing and not seeing;<sup>107</sup> environmental states of light and darkness; the spectrum of bodily health or lack of it and an associated variety of healing modalities, weighted differently at different times since diagnosis; the balance between seeing and other modes of sensory perception and the ongoing positioning and re-positioning of the self in relation to the experience of cultural othering and stereotyping that accompanies disability.

*Finding Aid* alludes to the demands imposed by all of these conditions; but the re-orientation it refers to most specifically is the key issue of access, which with sight loss abruptly becomes a painful process of negotiation.

The work takes the basic form of a body map. While maps of the human body have their origins in traditional Chinese acupuncture and the Hindu and tantric traditions (Meyburgh, 2006:18), as contemporary creative expressions, they are explicitly located within the paradigm of therapeutic art. In South Africa, such interventions generally take place in the context of workshops aimed at empowering, amongst others, victims of trauma and people living with HIV.<sup>108</sup>

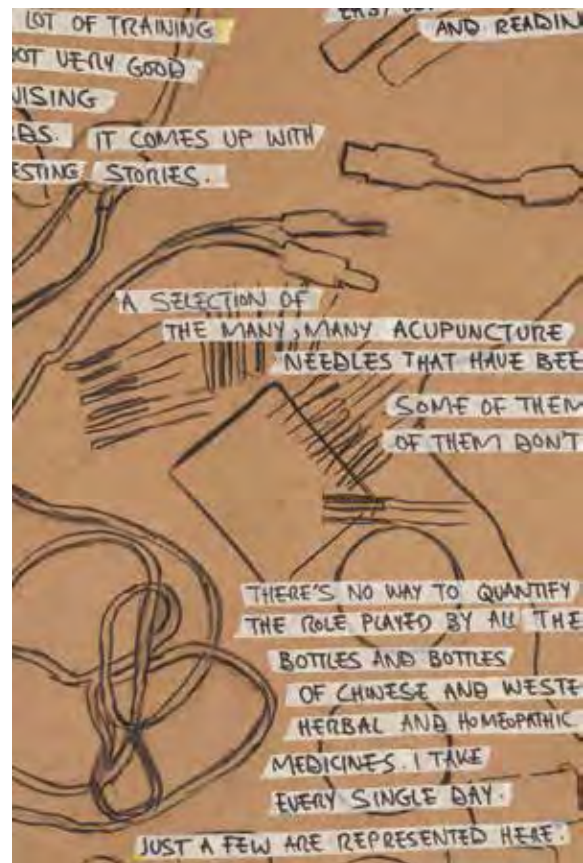

107 The spectrum referred to here is elaborated on by Joseph Wapner in the following way: 'Most of us "blind" people, that is people who are considered legally-blind, have some degree of partial sight ... it sometimes seems as though the concept of blindness is envisioned as an "either-or" condition — either you see normally or you need a cane and a guide dog; either you see or you don't. Most people can't tell immediately by looking at me that I'm legally blind. Because my peripheral vision is partially intact, I don't generally need a cane. I don't wear the tell-tale, medical-issue dark visor glasses. I don't have a dog — I mean, I do, but most of the time I'm the one guiding her around. Despite all this, the visual information that I am able to gather about my immediate environment is a significantly abstracted and confusing version of my surrounding' (Wapner, 2013).

108 The website of The Memory Box Project, a community outreach programme started in 2001, by the UCT-based Aids and Society Research Unit (ASRU) explains that 'In the workshops, participants trace the shape of their body and add information about the workings of the human body and HIV/AIDS. The body map is used as a way to lead people through exercises that build a holistic understanding of HIV, including issues



In contrast to the therapeutic body map model, in which the focus is on the body itself, In *Finding Aid*, the focus is less on my own body than on its relationship to a host of artefacts that are depicted as surrounding it. Here my body is presented literally as a ‘thing among things’ (Merleau-Ponty, 1964:163) — in this case, those things that it needs to use to gain access both to the archive as the site of my research as well as to art-making in response to this archive.

My body outline, executed diagrammatically in graphite on thin card, is surrounded and in some cases slightly overlapped by the outlines of an array of artefacts. These range from recording device through magnifying glasses to large font keyboard, and from iPod and docking station to hat and sunglasses. I use all of them in my efforts to access the archival collection, to write up my research, to make art and simply to deal with the routines of daily existence, which impaired vision has transformed from taken-for-granted banalities to a series of small but time-consuming challenges.

Superimposed on these outlines is a layer of labelling, handwritten in thick felt-tipped black pen on roughly torn strips of masking tape. While these labels reference the practice of cataloguing, to the extent that they refuse the neatness and order usually associated with computer-generated labels

---

such as social support, nutrition and how to access and adhere to antiretroviral treatment’ (Bambanani Group, n.d). In the context of trauma, Tanya Meyburgh explains that body mapping ‘... may assist in distancing the traumatised individual from their experience, and create the opportunity to process the experience on a non-verbal level before exploring it verbally’ (Meyburgh, 2006:18).

commonly used for institutional archival or museum collections, they also retain their connection to the realm of individual experience that the practice of body mapping taps into. They are also personal in a very specific way: firstly, the necessity to use large letters to write and read successfully with seeing difficulties has determined their form; and secondly, their torn edges and tendency to lift messily from the cardboard ground directly express the increased crudity that comes with poor vision. Lastly, as the examples below show, in the way they refer to the artefacts they describe and their role in my re-orientation process, their tone is resolutely personal:

‘I used to love the sunshine, but now everything is different. Outdoors and indoors, I struggle with light.’

‘Sunglasses are even more vital than the hat!!! I wear them most of the time. Sometimes I balance them above my glasses. This elicits many stares, jokes and comments.’

‘Another of my many glasses cleaning cloths. I now have quite a collection of these little cloths. You can’t have too many of them, because obviously when you can’t see well, dirty lenses make it even harder.’

On *Slantways*, *Finding Aid* was placed behind a thick, 2m long vertical glass panel that is bolted 10cm in front of the wall behind it. This wall forms one side of a metre-wide passage way, directly behind (but accessible from) the main space of the gallery. The glass panel (referred to above) is located directly opposite a seldom-used pair of doors opening onto a parking lot behind the Harry



Oppenheimer institute.<sup>109</sup> The fact that these doors were closed and shuttered for the duration of the show made it impossible for the viewer to step back to see the whole work from a comfortable viewing distance. This imposed claustrophobic awkwardness forced an intimate engagement with the work; but more importantly, it also replicated the effects of the extremely restricted visual field that many sight impaired people, including me, experience.

This placement was an important choice. As the map was initially not visible, without a commitment to explore the space thoroughly, it was easy to miss. The placement was used to designate the often hidden nature of disability, as well as its concealed relevance to the thematic concerns of *Slantways*.

## Hoard

Since it was always intended to be a relatively large-scale work dealing with the Manuscripts and Archives object collection as a whole, from the earliest days of its making in 2011, I conceived of *Hoard* as the centrepiece for my envisaged PhD exhibition. While I had not anticipated that I would have the opportunity to show the work on the South African Pavilion at the Venice Biennale in 2013, the need to develop the work to its full potential for this iteration had significant consequences for its conceptual development, which I will discuss below.

The idea for *Hoard* came to me in late 2011, as I grappled with the problem of finding a means, or several means, practically to implement the proposed creative focus of my PhD project. At this stage, how to do this was not yet clear. Though I had been a diligent interviewer, and the things had yielded up interesting stories as a consequence, how these stories could be worked with, in other words, the trajectory or trajectories for the practical component of my PhD, still eluded me.

To complicate matters thoroughly, this was the time at which I found myself squaring up to the enormous personal challenge of readjusting to visual impairment. I was aware that I needed to develop strategies for making artwork, not only for the PhD, but also in the longer term, as a way of re-imagining the rest of my life as an artist.

---

109 This arrangement was designed with the display of vinyl texts in mind, should this entrance to the gallery be used for any particular exhibition. For my own exhibition I chose to use the internal entrance to the gallery.

These two very different issues came together when it was suggested to me that I make my own clay versions of the things from the collection. As I had not worked with clay for approximately 40 years, I was rather sceptical of this approach, but in the absence of any better ideas and in recognition of the painful fact that to adopt a purely visual approach to my work was and is no longer viable, I decided to try. In late 2011, armed with a packet of modelling clay and the manager of the Manuscripts and Archives Department's generous permission for this rather unorthodox research methodology, I visited the archive and sculpted my first clay sculpture since the curly-tailed terracotta dog I had made in 1971.

As it happened, this new clay version of Ray Alexander's plastic hairbrush,<sup>110</sup> though decidedly flawed, had a certain chunky tactility which encouraged me to experiment further. Slowly, a small collection of odd, but visually interesting clay versions of the things began to accumulate in my studio.

As is often my experience in producing artwork, once the making process was underway, I gained more clarity on my own motivations for and focus in making this work. I realised now that it was the overall 'feel' of the collection, its neglected and melancholy air, together with the irreversible blemish of its colonial origins and associations that seemed to demand my attention, particularly when contrasted with the original value ascribed to it by Immelman. I wished to make work that commented on this odd collection, whose every element had (evidently) once been valued, was now not particularly valued but was still dutifully (though not especially lovingly) conserved, protected by an institutional paradigm that might conceivably be contested, but has been preserved by



---

110 See the discussion of *Entanglement* below.

unquestioned inherited archival policy.

Consisting in its final form of some 200 roughly-made artefacts, *Hoard* presents an entirely new, imposter collection based on the Manuscripts and Archives object collection, but ultimately exceeding it in its references (see below).

This new collection, recalling a golden treasure unearthed on an imagined archaeological dig, seeks ironically to comment on the issue of value in the archive. Despite their convincingly golden appearance — I was asked whether the work was made of real gold several times by members of the Italian installation team in Venice — these new artefacts were produced from modelling clay spray-painted gold, underlining the potential contradictions and inconsistencies in the assignation of value in the archive. In all three iterations of *Hoard*, the issue of value was emphasised by the display of the new collection against a rich, royal blue silk velvet ground.

Each of the sculpted things making up the imposter collection is marked by some degree of wonkiness: I intentionally abandoned the scale of the originals, and omitted or altered details that I found superfluous, or that I could not see well. In this way, the imposters remain faithful to the form of the originals up to a point, but are at the same time different.

Aside from adding to their visual appeal and underscoring their ironic questioning of issues relating to the ascription of value in the archive, my combined abandonment of scale, use of a gold finish and relatively relaxed attitude in terms of rendering the artefacts had two important consequences for the work. Firstly, overriding the archival things' innate and vastly varied materialities and usurping them with the new one provided by modelling clay spray-painted gold allowed for a sense of aesthetic and material coherence that is entirely lacking in the original collection, in a way speaking back to its quirky lack of taxonomy and offering up a replacement classification that only an artwork, in a process of over-riding or re-inscribing, can provide.

Secondly, this approach refers to my visual impairment and the limitations it imposes in terms of what I am able to see, and, as it were, pushed viewers to see in the way that people with less than perfect vision do.

### ***First iteration – Imperfect Librarian***

In March 2012, an exhibition was held at the Michaelis Gallery to show the work in progress of the six postgraduate students affiliated to the ARC programme at the school. For this exhibition, *Imperfect Librarian*, I decided to use *Hoard* (at that stage named *The Treasure*) to interrogate commonly held assumptions about value in terms of archival collections.

This was not the first time that I had explored the issue of value and what is considered to be valuable in my art work. In my earlier work, using ephemeral novelties, I had also engaged with the sliding scale of the value of material things, often seeking to disrupt categories like ‘throwaway’, ‘precious’ and ‘beautiful’, in the interests of proposing a new, personalised set of criteria for the assignation of value (see Appendix 1).

My strategy now was to juxtapose a display of a section of the Manuscripts and Archives object collection with a version of my own installation, *The People*, an ongoing collection of more than 2 000 small plastic humans, humanoids and their accessories, in the form of guns, food, petrol pumps and television sets, amongst others.<sup>111</sup> What intrigued me was that the relative value of these two collections is actually somewhat more complicated than might, on the face of it, be supposed. Although my installation *The People* might be seen as essentially valueless, or even as rescued rubbish, it is still rubbish that I have consciously considered and tried to display as precious. Also, by virtue of its assemblage as an installation, it is not inconceivable that, with the passage of time, it might one day be considered of some value in both monetary and historical terms.

On the other hand, as discussed in the introduction, many of the things from the archive may once have been precious to particular individuals, and were subsequently collected and held in the archive on the basis of the value of the information they could provide to future generations of scholars. However, at the time when I began working with them, most of them were arguably little more than rubbish, stored dutifully but fairly haphazardly in battered cardboard boxes, and otherwise largely ignored.

To highlight my interrogation of their relative value, I decided to display

---

111 This was the third iteration of this installation — I had previously shown it on *Monomania*, at the Goodman Cape Town in 2008 and on *Harbour* at the KZNSA in Durban in 2009.

the two collections on twin tables.<sup>112</sup> My hope was that this form of display would to some extent ‘flatten out’ their obvious enormous differences, and call into question the assumed disparities in value between them. However, there was an insurmountable obstacle to this approach, in the form of the manager of Manuscripts and Archives Department insistence on protecting the object collection within some form of locked vitrine.<sup>113</sup> Despite the twin bases for the two displays, the fact that one of them was covered<sup>114</sup> automatically emphasised the apparent ‘preciousness’ of the artefacts on that table. In contrast, the fact that I was unable to cover my own collection/ installation<sup>115</sup> would reinforce the idea of its apparent ‘valuelessness’.

While this flaw did not exactly invalidate my installation, it did slightly weaken it. To add another layer of meaning to the work, I therefore opted to augment the two tables (*The Things* and *The People*) with my fledgling clay object collection, *The Treasure*. I decided also to ‘open up’ and complicate the new collection by producing clay versions of a few of the toys from *The People* in addition to the new versions of the Manuscripts and Archives material. In the weeks preparing for the exhibition, its curator, Clare Butcher, suggested that I could consider ‘... [attributing] ... a similar status to each of the objects ... using some cheap material that looks valuable to play with the superficiality of the aesthetic of archival display and the materials therein’ (Claire Butcher, personal communication, 24 January 2012), and the idea of spraying the imposters gold was born.

For *Imperfect Librarian*, I displayed 21 gold artefacts, on loosely arranged royal blue velvet in two fairly shallow rectangular perspex boxes (95cm x 60cm x 25cm). Of these, six were new versions of elements of *The People*. In keeping with the spirit of the exhibition, this presentation was very experimental.

---

112 The surface of each of these tables measured 297.7m x75.5m.

113 An insistence that again reinforced the contradictions in the perceptions of the artefacts’ value; since though they were seemingly largely disregarded within the archive, as soon as they were to leave it, there was a need to assert their preciousness.

114 The table was equipped with a shallow perspex cover, which was locked to the base.

115 In all three of its iterations, I have displayed *The People* on an open shelf to emphasise the provisional nature of this collection/installation, and the fact that it has no definite shape and no foreseeable end. Though it would perhaps have been appropriate to discard this rule in the case of this iteration, there was also another obstacle to covering it — using a box cover would have limited it enormously in terms of depth, and would also have made it that much more difficult to see — the angle it was displayed at was already too low because of the need to use the two matching tables.

Though I considered it not altogether satisfactory,<sup>116</sup> I was excited by the possibilities of the golden collection for my PhD work.

### ***Second iteration – Leaving the incubator: from Michaelis to the rarefied world of the Venice Biennale***

The artefacts represented in this work were drawn from three rather different archival contexts, two of them institutional, and one personal. My new collection, after vigorously jumbling together the remade versions, coalesces at the imagined intersection of a venerated institutional treasure and a buccaneer's glimmering loot ... *Hoard* sets out to explore the ironies, anomalies and contradictions of these three collections, as well as to speculate on what amalgamating them in a new form might mean for a richer understanding of South African history, heritage and archiving. Many questions arise, none of them with easy answers. Might there be some value in revivifying the Manuscripts and Archives object collection, and the many other South African collections like it, despite their colonial taint? What value do personal archives hold? Might institutional collections be equally open to interpretations based strongly on feelings?

Artist's statement, *Imaginary Fact* catalogue (2013:34-35).

### ***Fine tuning 'Hoard' for the Biennale***

By the time I was presented with the opportunity to show *Hoard* on *Imaginary Fact* at the 55<sup>th</sup> Venice Biennale, I was confident that the work was conceptually and aesthetically sound, and had the potential to serve as the solo vehicle<sup>117</sup> to explore my ongoing concern with a range of issues relating to the value of archival collections (though for it to have an impact I needed to quadruple the number of sculpted artefacts making up the work). However, I was aware that the totally unexpected new context of the Biennale would require my conceptual strategy to evolve in ways that would not have been necessary if its

---

116 I felt that the blue velvet was successful as a ground against which to show the golden artefacts, but recognised that the exact form this ground took required further experimentation. Other elements of my work for this exhibition also needed revision — for one thing, I decided at this time to abandon the use of *The People* towards my PhD.

117 That is, without the collections displayed on the twin tables.

exhibition was confined to my final PhD show in Cape Town.

As I saw it, for an exhibition showcasing contemporary South African artists' engagement with the archive on an international fine art stage, an essential shift needed to take place. While it was important for the integrity and potency of the work for it to retain as much of its focus on the quirky particularities of the Manuscripts and Archives object collection as possible, it would now also need deliberately to speak more broadly as well as more directly about South Africa and its history.

In this regard, I understood the work's reference to gold to be productive. The obvious (and for this work essential) universal associations of gold with opulence and treasure aside, there is no other natural asset with anything near as far-reaching an effect on the history of this country. The establishment of the mining industry after the discovery of gold on the Witwatersrand in 1886 not only fundamentally shaped the urban landscape, but was instrumental in the development of racial capitalism in South Africa. What is more, the labour requirements of the mining sector have had far-reaching political, economic and social consequences, most notably in terms of land dispossession and the development of the oppressive migrant labour system. The effects of this history are very much present in this country to this day, so that the representation of gold by a South African artist must inevitably allude to it.

In terms of my selection of the elements making up the new collection for the show in Venice, there were strategic decisions to be taken. The majority of the colonial era artefacts in the Manuscripts and Archives collection are unprepossessing, everyday and even shabby. While for me, these things are an essential part of the installation, speaking to the issue of value in significant ways, I felt it was important to be sure to include those artefacts that more overtly resonate as symbols of colonial power and conquest. On reflection, I realised that even in this peculiar collection, such things do exist, in the form of a miniature gun, a miniature Bible, several crosses, a judge's gavel ... even the pen used by Queen Elizabeth to sign the visitors' book in the library in 1947, as a visual symbol can speak to the overwriting of one form of social relations by another. I had already made versions of some of these things, and now hurried to make the rest of them.

In addition to the colonial-era artefacts, it seemed important to represent more recent history, via new versions of the relatively few things in the

Manuscripts and Archives collection that speak of apartheid and the struggle for democracy. With this in mind, I made my own broken miniature South African flag, passbook, ANC badges and a gas canister to stand in for the one that was placed in the archive after the South African police took action against protesting students on UCT campus in the mid-1980s, but which has subsequently disappeared.

However, probably the most important strategic decision I took was to include new versions of a few significant items from the 11<sup>th</sup> Century Mapungubwe collection, housed at another South African university, the University of Pretoria.<sup>118</sup> The original versions of these things — the well-known and well-loved golden rhinoceros, the sceptre, the bowl and a large pile of beads — are all grave goods excavated from three Royal graves on Mapungubwe Hill. The inclusion of my new versions of these things enabled the referencing of South African history conceived on a far broader temporal scale, and resonating with the symbolic tropes of national identity-making. These artefacts also added an important layer in terms of the work's central focus on value: in contrast to most of the Manuscripts and Archives Department things, both in terms of the historical evidence of a thriving pre-colonial society the collection they form part of provides,<sup>119</sup> as well as in purely monetary terms, the (real) gold original versions of these artefacts have the undisputed status of priceless national assets.

Finally, I chose to replace all but one of the elements drawn from my collection/installation *The People* with items from my own archive that are at once more arbitrary, more personal and paradoxically more universal too — an earring my mother wore to a party in the late 1960s, for example, and a blue wooden building block from a set I played with as a child. In terms of value, these things fall at the opposite end of the spectrum from the Mapungubwe material, holding meaning and value for nobody but me. Outside the realm of

---

118 There is a certain irony to the fact that, since 1933 this collection has been housed at this renowned bastion of apartheid ideology at a time when the regime was at pains to disavow the existence of such indigenous pre-colonial societies in the interests of maintaining the myth of white superiority. According to Xolelwa Kashe-Katiya, under apartheid, the Archaeology Department at the university colluded with the regime to downplay the importance of the collection as a means to deal with this glaring contradiction of the central tenet of apartheid (2013:11).

119 Mapungubwe was declared a Unesco world heritage site in 2013. In Unesco's listing, it is described as '... presenting an unrivalled picture of the development of social and political structures over some 400 years' (Mapungubwe: S.A.'s lost...n.d.).

feeling and memory, where they serve as melancholic markers of experience, loss and the passage of time, such things are worth absolutely nothing; yet for the individuals they belong to, they may have a sentimental value so marked that it can compete with and even overwhelm more conventional ideas of what is worth holding on to. With these additions and selections, *Hoard* emerged as a work that I felt was able to hold its own on an exhibition with a broader scope and a totally different audience than the one I had initially anticipated.

### ***Pressures, constraints and potential shifts in meaning and reception***

Probably inevitably, though, there was a flipside to this coin. Showing *Hoard* on the Biennale also presented a completely new set of challenges. Even before the work left Cape Town, during the roughly four weeks of intense preparation leading up to the opening of *Imaginary Fact* in Venice on 31 May 2013, as the work moved out of my studio and into the projected conceptual and physical zones of the exhibition, I was aware of the exertion of various pressures on it, or more exactly on me in terms of its showing in Venice.

These pressures, ranging from tiny nudges, mild suggestions that I could respond to or ignore, to more forceful — and fateful — shoves in particular directions, came via instructions, expressed concerns and the sharing of pertinent information from the curator or sometimes the project manager. None of them related overtly to the way I had conceptualised *Hoard*, or the way in which it gelled conceptually within the show. In fact, I was confident that curator and fellow student Brenton Maart and I shared a very similar understanding of the multiple and open-ended creative potentialities of the archive, and were both equally engaged with and intrigued by the various overlapping ways in which artists choose to work with archives and archival material. Further, Maart's wholehearted endorsement of this particular work from its first experimental iteration on *Imperfect Librarian* in 2012 gave me confidence that he respected my intentions with this installation.

Rather, the questions and issues that arose related almost entirely to practical matters, such as time and budgetary constraints, as well as a range of intertwined logistical issues. However, although these matters had nothing overtly to do with the concept underlying the work, I soon recognised that how I responded to them would certainly affect the work, since different modes of

presentation must invariably privilege certain aspects of the work over others, and therefore bring some interpretations or readings to the fore at the expense of others. It began to dawn on me that each choice I made would have far-reaching consequences, and that I needed to tread very carefully.

### ***A list of pitfalls***

The first issue I was faced with was the curator's not unreasonable anxiety (which I shared fourfold) that the work might not survive its transportation to Venice, and would arrive smashed into a million fragments. This disastrous eventuality did not bear thinking about; but like a troublesome tooth that insists on constant attention from the tongue, it was very difficult to resist. Logically I was forced to admit that my own solution — the making of replicas of about five of the most fragile artefacts, which I laboriously carted off to Venice in my hand luggage — was utterly ludicrous, since there was no way of predicting which of the more than 80 things or sets of things would break.<sup>120</sup> Nevertheless, I strongly opposed Maart's repeated suggestion that I mitigate against the work's fragility by having it cast in metal. This, I felt, would not only alter its overall aesthetic feel in ways I was unable to predict, but would interfere with one of the most basic ways I had chosen to express the central theme of the questioning of value, namely the use of easily accessible and relatively cheap materials, modelling clay and spray paint. This approach allowed me to turn the archival obsession with preservation on its head, replacing it with the acceptance of the transience of all things. Fortunately, my resistance on these grounds was accepted (and as it turned out, due to expert packing, the work arrived totally intact).

The need to reach a compromise over the way in which the work was displayed was potentially far more troubling. As far as I was concerned, to allow the full range of potential associations and interpretations to be accessed, *Hoard* must be allowed to retain a certain essential, built-in ambiguity — that of its balance on the slippery cusp between the archive/museum and the far more indeterminate arena of contemporary fine art display. This became

---

<sup>120</sup> For me, the extent of the installation was very important. I felt that its size refers to the fact that such collections are to be found in scores of institutions, so that if it were to be reduced in size through breakage or loss, it would inevitably lose some of its impact.

even more important after the inclusion of my versions of the Mapungubwe elements, which refer explicitly to a national legacy which is both decidedly institutionalised, i.e. part of a university collection, and at the same time, is understood as an art treasure, with the treasure aspect made even more potent as a consequence of its value as gold. Now I experienced pressure to present and frame the work in such a way that it resonated far less with the museum or institutional collection and moved into the high-end, fine art display ambit that the Biennale obviously epitomises. These shifts were bound to have the effect of privileging certain interpretations of the work over others. At worst, I knew that certain associations might disappear altogether ... this was something I was determined to avoid as far as I was able to.

Partly for this reason, I could not accept Maart's initial suggestion that *Hoard* be displayed on a light box, a display solution that would have shifted the work very decisively into the realm of fine art display, to the detriment of its museal/archival associations. There was also a second, more personal reason for my rejection of this solution: I felt that it would have been anathema to an artist struggling with extreme light sensitivity. My counter suggestion, to install the work on a shelf covered in tightly stretched royal blue velvet, was accepted. Not only does this vivid colour together with the shiny, lavish nature of the fabric provide strong visual appeal, but at the same time it pushes the work's associations with opulence and treasure, while still retaining something of a museum display feel.

The next phase involved protracted negotiations over the amount of space required to do my work justice. Obviously on any group show, individual artists' desires in terms of the optimum showing of their work must at times be tempered in the interests of the general feel of the show. On this exhibition, there were further pressures, the direct result of the financial, time and other logistical constraints of staging a large South African group show in Venice. 11 separate works or bodies of work needed to be accommodated in a fairly small area, which necessitated the use of extensive dry walling. However, limitations on the budget meant that the need for dry walling had to compete with many other requirements. For some time, the percentage of the budget that could be allocated to dry walling was not finalised. This meant that, as the amount of dry walling to be installed expanded and contracted, so too did the amount of space available for my installation.

Initially, having been encouraged to make as much work as I felt necessary in the six weeks available to me, I had developed a design for my installation that necessitated 5m x 55cm. When it became clear that this requirement would exceed the limited space available to me, I accepted the compromise of two shelves, one above the other, each 2,5 m long by 50 cm wide. It was proposed that these shelves would be inserted into a drywall, with what I understood to be a kind of 'fish tank' effect.

Though this required a total reworking of my placement of the sculptures — there could no longer be a central focus to the work, which I regretted — I was happy with this solution, as I welcomed the associations with familiar museum displays that the two shelves might allow for. One example is provided by the glass shelves of the Asian galleries in the British Museum, in which many Buddhist and Hindu devotional sculptures, usually made of gold or other metal, are displayed.

I therefore re-organised the placement and orientation of the elements in the installation to fit these new specifications. However, after a few days, I was told that the final stringent constraints on the amount of dry walling available meant that my two shelves would be viewed from the front only after all ... again, I changed my layout.

These arrangements and re-arrangements were time consuming and slightly destabilising, but the final and most challenging chapter in the saga of my two shelves was yet to come, and had more potential for disaster than anything I had previously been able to imagine. On my arrival in Venice, I was appalled to discover that the top shelf had been placed far too high, with the potentially disastrous effect that anybody shorter than me would not be able to see the work from above, as I had made it to be seen; and even I, at 1.75m, would have seen most of the artefacts largely from the side rather than from directly above. Altering the shelf was not a simple matter, as a set of metal bars required for lighting purposes were already in place under the shelf, and the project manager, Bie Venter, was adamant that, by this stage, a few days before the opening, it was impossible to remake the shelves. I could not accept the suggestion that the incorrect height of the shelf was less of a problem than I was imagining it to be, and there followed many hours of discussions and negotiations. Finally, these bore fruit when Maart had a brilliant idea: we would tilt both shelves about 30 degrees forward, so that the work would be displayed at an angle.

This solution was still extremely challenging, as it required further experimentation and meticulous attention during installation to ensure that the work didn't roll down and off the shelves. Finally, though, it worked so well that the sense of latent instability it gave the two shelves seemed even perhaps to have some advantage over flat shelves ... for me, this was a miraculous example of finding a solution via lateral thinking.

So much for the logistical constraints; there were still others I had to deal with. For me, the most potentially damaging push along the continuum from museum to fine art display came in the form of a curatorial rejection of any form of labelling of the things making up *Hoard*. I was greatly troubled by this decision, particularly since it came hand-in-hand with the decision not to have any wall texts.<sup>121</sup>

I repeatedly made efforts to persuade Maart of the importance of including some form of labelling for the work, which I felt would lose a layer of meaning without it — not purely because the audience couldn't possibly know what often very obscure original artefacts my new versions referred to, but also because it would strip off an important layer of the work relating to the archival practice of providing the provenance of every item. My suggestions, though — to use either typed or handwritten labels made of cardboard or clay, or to make a map like diagram to accompany the work — were rejected as potentially messy.

Ultimately, the deciding factor was that there was an impossibly short time in which to resolve this issue by adopting any of these solutions anyway. Instead, I eventually opted for the compromise of a touch screen tablet finding aid system with a screen for each shelf. Each of the two screens allowed the viewer, on touching the photograph of a selected item, to be taken to an enlarged version of the same image together with a description of that thing, its provenance and original collection.<sup>122</sup> Though this solution was nothing like any of my own anticipated versions of labelling, I felt that its extremely hi-tech, contemporary feel had the potential to work in an interesting way when juxtaposed with the sculptures making up *Hoard*, which have an inherently crude and handmade feel. One disadvantage to the solution was the laziness

---

121 This was subsequently changed, and wall texts were in place for most of the duration of the exhibition.

122 See Appendix 2.



that this technology, particularly at an art exhibition on the scale of the Biennale, encourages: it is a rare viewer who bothers to investigate more than one or two of the artefacts using this kind of technology.<sup>123</sup> Nevertheless, the shift was certainly not altogether disadvantageous, as it further facilitated the thorough transformation of the collection into something altogether different and new.

As a postscript on this particular issue, it is important to add that the touch screens did not work well, and needed continually to be rebooted. The effect was that few visitors to the show accessed the individual descriptions of the artefacts on display. This inspired in me a sense of regret for the original solutions I had proposed, particularly the imagined map-like diagram.

### ***'Hoard' in the context of 'Imaginary Fact'***

The conceptual framework for *Imaginary Fact: Contemporary South African Art and the Archive* was developed by Brenton Maart. While, as the curator for a national pavilion show, there was no obligation for him to refer in any way to

---

123 Though whether labels would inspire greater attention is debatable — perhaps this lack of attention is simply a symptom of the severe sensory overload we all face.

the overarching theme of the 2013 Biennale, *The Encyclopedic Palace*, in the South African exhibition, for Maart his proposed focus on the work of South African artists engaging with archival material seemed particularly appropriate (personal communication, 21 June 2013).

Biennale curator Gioni Massimo's conceptual starting point was the museum to house all the world's knowledge, imagined by outsider artist Marino Auriti in 1955. While a close reading of Massimo's curatorial statement advances a nuanced and multi-layered set of meanings in terms of the intended application of this concept (see below), to the extent that the institution imagined by Auriti would certainly be akin to a vast archive, on one level *Imaginary Fact* does have a particularly strong resonance with *The Encyclopedic Palace*.

In his curatorial essay, Maart describes the inter-related conceptual motivations informing *Imaginary Fact*. Firstly, he wishes to demonstrate that 'using the products of history as source material ... archives have now become the building blocks for creative action' (Maart, 2013:25), and that South African art is playing a significant part in the development of this trend (Maart, 2013:25). He states further that he wishes to use the work of artists who engage with archival material '... to show how artists may be considered as activists in the evolution of democracy' (Maart, 2013:25).

My own art work has certainly always had some degree of archival focus, as befits the inveterate collector that I have, until very recently, enjoyed being; though before the making of my directly archive-related current body of work, my archive of choice was the rather unbounded and intangible one provided by the market place, the arena of late capitalist mass consumption that is an intrinsic part of the daily affairs of contemporary human beings. As for activism, I am able to present myself as an activist in the narrow sense of acting to liberate the material I am working with from the oppressive constraints of their current archival regimen; and to this add the hope that my work might promote a more probing and critical approach to the material we can access in formal archives, and point the way to potentially generative ways of questioning and destabilising conventional or limited readings of the history associated with this material. Further than this I could not presume to go.

For the purposes of Maart's catalogue essay, the artists represented on the exhibition fall under one of the following rubrics: 'administering the archive',

‘performing the archive’, ‘spatialisation of the archive’, ‘archival absences’ and ‘surrogate collections of the African state.’ My own work is discussed together with that of Sue Williamson and Sam Nhlengethwa under the first of these headings, ‘Administering the Archive.’

Since artwork tends to resist neat classifications, to focus on Maart’s use of these categories might be seen as overly exacting.<sup>124</sup> However, it can be argued that, if the definition of ‘to administer’ is understood to be ‘to manage or supervise the execution, use, or conduct of’ (“Administer, v.”, n.d.),<sup>125</sup> I do question its use in this context — particularly when it is juxtaposed with the use of ‘activism’ as discussed above, a term which expresses quite a different set of meanings.

While, to the degree that Williamson’s work presents a straightforward photographic record of every page of an apartheid pass book, it might, at a stretch, be seen as a form of administration, this work is still not administering this particular archive in the sense of maintaining the status quo. Rather, the strength of the work is that it holds that status quo to account simply by laying the facts bare. In the case of Nhlengethwa’s supremely skilful use of collage to manipulate and re-process his archival raw materials, something more akin to transformation than administration is surely at play. As for my own work, which makes a point of mixing up archives and presenting new versions of their elements, this heading also seems misleading. In the introduction to his curatorial essay, Maart outlines various methodologies used by artists working with the archive, including ‘... translation (into new and evolving languages), interpretation (into new and evolving meanings), and mediation (from one medium to another), sometimes used individually, sometimes in combination, but often to startling effect’ (Maart, 2013:10). As opposed to the term ‘administration’, for me ‘translation’ and ‘mediation’ are more in keeping with my aspirations for this body of work — namely, to interrogate and subvert the assumed status quo that ‘administer’ suggests the careful maintenance of.

This seems particularly relevant as Maart, following Bourdieu, asserts that

... proactive archive practitioners have the agency to change their environment

---

124 In other words it might be fairer to the spirit of Maart’s essay to consider these headings as very broadly understood approaches to artwork engaging with archival material and leave it at that ...

125 Other meanings given include a: to mete out: dispense <administer punishment>; b: to give ritually <administer the last rites> c: give remedially <administer a dose of medicine> (“Administer, v.”, n.d.).

... At its simplest level, this logic replaces the rigidity of dogma (the grand narrative) with the fluidity of cultural agency (new and constantly evolving narratives that shift with each context) (Maart, 2013:14).

Maart also refers to *Hoard* to ask what he names as ‘the most important question of the exhibition’, namely whether

... the situational and the specific — as evidenced in the diversity of exhibited case studies in *Hoard* — ... [could] ... work as tools against the violent gloss-over — arising by the presentation of the “norm”, and its negation of dissenting voices and experiences — of the preconceived conclusions of a research process? (Maart, 2013:14).

Hopefully the reference to my own work in the interests of expressing this question suggests that (at least for Maart), the adaptations made to the work to fit the international context of the Biennale, still allow it to retain enough specificity to function as a case study that scrutinizes and interrogates assumptions about value in relation to the Manuscripts and Archive object collection.

### ***My work in the context of ‘The Encyclopedic Palace’***

Gioni’s curatorial starting point for *The Encyclopedic Palace* was Italian-American outsider artist Marino Auriti’s utopian fantasy of a massive museum to house all the world’s knowledge, to be built in Washington DC. This building was to stand 700 m tall and cover 16 square city blocks (Gioni, 2013). Auriti’s original model of this imaginary building, previously housed in the American Folk Art Museum in New York, was the first artwork visitors encountered as they entered the exhibition.

As mentioned above, for this show, Auriti’s naive but captivating utopian dream is no more than a starting point, a kind of touchstone for the curator’s ambitions for the exhibition. According to Gioni,

... the dream of a universal, all-embracing knowledge crops up throughout the history of art and humanity, as one that eccentrics like Auriti share with many other artists, writers, scientists, and self-proclaimed prophets who have tried — often in vain — to fashion an image of the world that will capture its infinite



variety and richness. Today, as we grapple with a constant flood of information, such attempts seem even more necessary and even more desperate (Gioni, 2013).

One of the stated intentions of the show, via ‘an anthropological approach to the study of images’ is a focus ‘... on the realms of the imaginary and the functions of the imagination’ (La Biennale di Venezia, 2013). In the interests of doing this, the exhibition ‘... loosely ... follow[s] ... the typical layout of sixteenth and seventeenth-century cabinets of curiosities’ (La Biennale di Venezia, 2013).

The all-encompassing approach to what is deemed worthy of exhibiting generated by this focus on the imagination is the most notable strength of this powerful exhibition. However, a narrower focus on Auriti’s conception of a palace of knowledge allows for interesting resonances in my own work, *Hoard*, to surface.

As work that has developed in response to an object collection, *Hoard* invokes the relationship that collecting has to both the infinite — the enormous, overwhelming freight of collectible material circulating in the world — and the finite boundaries of closure — the putative final element, the glorious ‘finishing touch’ to the collection that closes the circle and brings the

hunt to an end. This paradox is a part of any collecting process, Immelman's included. It is also necessarily at the heart of Auriti's fantasy, since clearly, even in 1955, it was quite impossible to contain all the world's knowledge, and is exponentially more so today — but the idea of trying to do this is still intriguing.<sup>126</sup>

A second aspect of any work engaging with a collection is the issue of taxonomy. With *Hoard*, I refer to and re-present three 'taxonomy-less' collections, but at the same time invent and employ both an idiosyncratic personalised taxonomy in terms of my layout, as well as impose one via my chosen materials that allows the imposter collection to cohere in a way that the original never did. Unfortunately, there is no record of the taxonomies Auriti might have imagined employing in his curatorship of all the knowledge of humanity in the Encyclopedic Palace — but the fact that his model has 136 storeys implies many collections, presumably with countless subdivisions.

Finally, Auriti's imaginary all-encompassing museum of knowledge to some degree echoes a certain aspect of the university, which (though it also presents itself as many other things), can be understood to provide an overarching structure for the 'gathering in' and control of the knowledge that is subsequently transmitted to students and scholars on an ongoing basis.<sup>127</sup> While, as discussed in the Introduction, the Manuscripts and Archives object collection on which *Hoard* is largely based is atypical of the conventional discipline-based collections that prevail in universities, Immelman's collecting policy was aimed at the preservation of knowledge for future generations of university-based scholars. Though Auriti, as an outsider artist, held a vastly different subject position to the scholar-librarian Immelman, and though they lived in altogether different parts of the world and never met, in the 1950s, when Auriti filed his application at the US patent office for *The Encyclopedic Palace* and Immelman enthusiastically opened his Manuscripts and Archives Department and threw himself into collecting material for it, both were acting on the same impulse.

---

126 This idea was also part of my rationale in my own collecting days — see Appendix 1.

127 This is not to imply a simplistic and one way process of transmission.

### ***Third iteration – ‘Hoard’ on ‘Slantways’***

For the purposes of my PhD exhibition, *Hoard* was presented in a way that differed markedly from its display in Venice. This was partially due to practical considerations: the shelving unit that had been constructed for *Imaginary Fact* had been abandoned in Venice, and the touch screen finding aid devised in 2013 had proved technically problematic for the entire duration of the Biennale. New solutions had thus to be sought, both for display and for labelling.

However, another issue also needed to be foregrounded for this exhibition as opposed to for the one in Venice. This was the work’s material and conceptual origins within the university in which it was being exhibited, as well as its ongoing links to that university via its critical engagement with the UCT archive.

Ultimately, the imposter collection making up *Hoard* was displayed in four identical customised glass-topped cabinets, each measuring 125cm by 70cm, and standing 100cm off the floor. In place of the unreliable electronic finding aid, a narrow, angled wooden shelf bearing printed textual descriptions and photographic images of the things within the relevant cabinet was attached to each cabinet. This was to some degree reminiscent of labelling put in place in museums, with one significant difference. In keeping with the emphasis on sight and seeing, access and lack of it, the text was made bold and readable, even to me.

The slightly old-fashioned look and feel of the new cabinets recalls the era in which Immelman worked at UCT, between the late 1940s and 1970. In fact, though slightly more elegant in their shape and proportion, these cabinets are not dissimilar to those still used for displays at various points throughout the university. I also used one of these original UCT cabinets for my satellite exhibit of a selection of the artefacts that were remade for *Hoard* (see below).

As *Hoard* was the centrepiece, before I arrived at display strategies for the exhibition, I had recognised the need to make full use of the particularities of the CAS gallery floor-plan to maximise its impact. Actually, this turned out to be a dialectical rather than a one-way process: because the CAS Gallery is a multi-functional space, complete with features that are either visually mundane, distracting or even ugly, such as two large windows (fortunately with metal shutters) and a highly visible non-removable overhead projector, it was



essential to place the work very sensitively, in the interests of activating the space as the setting for a series of imaginative encounters.

Possibly the most noticeable design feature of the gallery space is a very slightly raised section of wooden strip flooring, measuring 6.63m x 4.85m, which covers a significant portion of the floor space on one side of the gallery, running widthways from slightly to the left of the centre point of the room towards the east wall. This differentiated section contrasts noticeably with the grey paint finish of the rest of the floor, and presented the opportunity to position *Hoard* in such a way that its centrality to the body of work on exhibit was highlighted, by demarcating a kind of visual frame for it. One of the four cabinets was accordingly placed in roughly the centre of each side of the wooden rectangle, in such a way that visitors were able easily to access the work from all sides.

### ***'Hoard' understood as an assemblage***

If *Hoard* is considered from a different angle, not as an artwork in the usual sense of that term, namely the creative product of an artist or artists, but rather as an assemblage, made up of non-human as well as human actants, the assortment of things from the Manuscripts and Archives object collection



that I made new versions of, can be considered as the primary set of material or 'thing' actants. A second set consisted of those I chose to re-make from my personal archive, and a third was made up of the things I chose from the Mapungubwe collection.

As actants, these elements selected from outside the Manuscripts and Archives collection had an important part to play: in combination, their presence enhanced the effect of the artwork, not only in terms of the key conceptual issue of value, but also importantly in terms of the resonances they brought to the work.

Stephen Greenblatt explains the term 'resonance' as

... the power of the object displayed to reach out beyond its formal boundaries to a larger world, to evoke in the viewer the complex, dynamic cultural forces from which it has emerged, and for which — as metaphor or more simply, as metonymy — it may be taken by a viewer to stand (Greenblatt, 1990:20).

Following this understanding, the chief resonance injected into the assemblage by the inclusion of my own artefacts, is that of the affective qualities of the personal sphere, whereas the artefacts from the Mapungubwe collection carry the very different resonance of much celebrated cultural symbols of South

African nationhood, reclaimed from the oppressive colonial and apartheid past.<sup>128</sup>

A completely different set of non-human actants within the assemblage, and one that is invisible from the standpoint of the viewer of the final artwork, consisted of the assistive devices I used to research the material — most obviously, magnifying glasses of various sizes and strengths for scrutinising the things before and sometimes while trying to make versions of them, but also the recorder I used to interview Lesley Hart and past UCT librarians Tanya Barben and Gerald Quinn, to throw more light on the history of the collection. Many layers of things, some less obviously and directly helpful than others, can be considered as supports in my mission to pursue the research process under difficult circumstances, as is evidenced by the artwork *Finding Aid: The Archive partially seen*.

As regards the inherent qualities of materials and their vitality, Bennett points out that

Instead of a formative power detachable from matter, artisans (and mechanics, cooks, builders, cleaners and anyone else intimate with things) encounter a creative materiality with incipient tendencies and propensities, which are variably enacted depending on the other forces, affects, or bodies with which they come into close contact (Bennett, 2010:56).

In terms of my own involvement with materials as the artist making *Hoard*, the modelling clay and spray paint with which I chose to make my sham collection can be considered as further material actants. Though I did choose to use these materials, at the beginning of the making process I was unfamiliar with them, and could not anticipate how they might combine.

Connor notes that for Bachelard, clay, along with ‘... snow, ice-cream, mashed potato and putty ... is one form of what ... [he] ... terms the “ideal paste”’: it is infinitely malleable, while yet never becoming entirely liquid, for at that point it would begin to escape me’ (Connor, 2013:5). Elsewhere, Connor is quoted as elaborating on this ideal paste as ‘the perfect synthesis of stiffness and softness, a marvellous equilibrium of yielding and resisting forces’ (Connor, 2004:223).

---

128 In the case of the gold rhino, its popularity and use as a symbol of South African heritage is such that it might in fact be considered as a form of national kitsch.



The obliging pliability of the modelling clay I used — a ‘perfect paste’ that gives the things it is used to make a gently rounded, ‘blobby’ and bulging look and feel — facilitated the blurring of detail I required in the sculptures making up *Hoard*, as well as producing a markedly tactile quality. Furthermore, it was thanks to the way this clay combined with the rich gold of the spray paint that the work exuded the ‘feel’ of an imaginary golden treasure, as discussed above. This effect was further enhanced by the display of the finished sculptures on another essential material actant in the assemblage, a royal blue silk velvet ground, resonant of the opulent pageantry of stately or regal ceremonial garb.

The four wood-and-glass cases in which *Hoard* was presented for the final exhibition can also be considered as material actants in this assemblage, speaking obliquely of the university and its past, while retaining a relationship with the practices of fine art display — and, of course, while providing a particular material frame within which to display and contain the artwork itself.

In terms of the human actants in this assemblage, I was obviously key as the things’ interlocutor and researcher, and as the artist who conceptualised and produced the work and the overarching methodological approach for the exhibition as a whole. Yet without R.F.M. Immelman, who chose to collect these

artefacts in the first place, the project would never have come into being.<sup>129</sup> My supervisors, who provided support and guidance, were a third pair of human actants, and Lesley Hart, manager of the Manuscripts and Archives Department at the time I was researching the artefacts and beginning to produce the sculptures making up *Hoard* was a fourth. Her choices, decisions and responses to my requests and questions often had particular effects on what I chose or was able to produce. For example, I was discouraged from working with any of the things that were more valuable in monetary terms, such as the silver medallions, spoons and inkstand.<sup>130</sup>

Even the librarians working in the Manuscripts and Archives Department can be considered as human actants in this assemblage, to the extent that their levels of interest in assisting me to access the things within the archive sometimes determined what I could or could not focus on in the project.<sup>131</sup>

The conditions and contingencies of the 55<sup>th</sup> Venice Biennale (which might itself be considered as an enormous and complex assemblage), and the human actants working in the South African Pavilion team also played their part. In particular, the curator's encouragement to produce as much work as possible, as well as his reluctance to include labels for the work as it was displayed on *Imaginary Fact* were important in shaping my process and the choices I made for labelling the work for my later PhD exhibition.

For Bennett, 'Structures, surroundings, and contexts make a difference to outcomes, but they are not quite vibrant matter' (Bennett, 2010:29). No doubt this is technically true; yet in the case of this, in fact every, exhibition, it seems to me that the gallery space is as important as any of the other material or human actants involved. As a result, though its effects are not quite those Bennett refers to in terms of the energies of materials and humans, I consider the CAS Gallery as a quasi-actant, to the extent that its spatial and design features called for particular solutions in terms of display that had an effect on my final choices, especially in terms of the positioning of *Hoard*.

---

129 As referenced in the artwork *Homage to R.F.M Immelman*, discussed below.

130 These decisions sometimes seemed fairly arbitrary, however — I was allowed to use the moonstone bracelet, as well as the amethyst and gold brooch.

131 For example, one of the librarians once showed me a dried rose, attached to one of the collections. Having lost my notes about this item, I asked him some time later if he could locate it for me again, but he was unable to do so.

# Entanglement

## Archival thing: the plastic hairbrush



### *A collection of hairbrushes*

BC 1081, which consists of the papers of veteran trade unionist, Secretary of the South African Communist Party (SACP) and founder of The Federation of South African Women (FEDSAW)<sup>132</sup> Ray Alexander (1913–2004) and her equally well-known husband Professor Jack Simons, constitutes a sizeable and important fonds in the archive (Jack and Ray Simons Collection). The approximately 7 200 items in this collection relate to a variety of subject matter, including the South African trade union movement, the ANC, the SACP, the couple's research into health, class and colour in South Africa, the law and the status of South African women in the era in which the Simons were politically active, between 1930 and 1980. The collection was donated to the Manuscripts and Archives Department in 1995 by the Simons' daughter, Tanya Barben.

Several things are attached to this collection and listed in the catalogue, including two boxes of academic vestments, a wooden African mask, a folding fan, six wood and ivory letter openers and the name-plate from Entabeni, the Simons' home in Cape Town.

Also amongst the artefacts is a decorative silver-plated hairbrush and mirror set, as well as three single hairbrushes. The name 'Ray', engraved in an ornate longhand, appears on both pieces of the brush and mirror set, and the words 'Sweet Workers Union, C T, 1940' are engraved on the handle of

---

132 Founded in 1954.



the mirror. 'To Ray' is engraved on the back of one of the single brushes, with the words, 'From FCWU<sup>133</sup> Paarl 7-10-53' appearing on the handle. A handwritten note within the box containing a tortoiseshell brush

explains that it was 'A birthday gift from Jack to Ray'.

Finally, there is a slightly scuffed silver and black plastic hairbrush, with the trademark 'Structa' printed on its handle in bold black letters. Similar hairbrushes can be found in their thousands in supermarkets and chemist shops around the country.

My initial encounter with these artefacts in April 2011 was confusing. Firstly, in contrast to almost all the other things I had decided to work with,<sup>134</sup> the brushes and mirror were still attached to their original collection. This alerted me for the first time to the fact that the archive harbours, but also in a sense hides many more things than had first been obvious to me. In theory, these things are being held for scholarly examination. However, the fact that, in terms of the epistemological hierarchy of the archive, they are valued less than paper-based materials, as well as their very random nature as a collection of things relating to a particular individual, means that they may well only be unearthed by chance.

Secondly, since the hairbrushes and mirror had been donated in 1995, long after the era in which artefacts were enthusiastically accepted into the collection, the question of why this part of the donation had been accepted also initially puzzled me. However, it soon became clear that the engraved brushes had been donated because their inscriptions both mark the time during

---

133 Food and Canning Workers Union. Alexander founded the union in 1941, and acted as the General Secretary from the early 1940s until she received the first of a series of banning orders in 1953 (South African History Online, n.d.).

134 With the exception of the cloth associated with Olive Schreiner, which is also attached to the Olive Schreiner collection.

which Alexander worked in the Sweet Workers' and Food and Canning Workers' Unions, and also serve as evidence of the esteem in which she was held within the trade union movement.

Though Jack's birthday gift to Ray cannot be understood in the same way, an interview with Alexander's daughter Mary Simons shed further light on the import of the hairbrushes in Alexander's life. Simons explained that her mother's long blonde hair had been a dominant feature of her persona, remembered by all who had encountered her.<sup>135</sup> According to Simons, the care her mother paid to her hair amounted to 'a weekly ritual':

Each Friday night, she oiled her hair with coconut oil, using a sort of heating device filled with methylated spirits to melt the oil. The following day she would wash it, adding lemon juice to the final rinsing water. After she had dried it in the sun, my father would brush it ... it was a very loving thing (Mary Simons, interview, 12 March 2013).

At least from the point of view of the donor — since (it seems to me) unfortunately reference to the hair brushing ritual is absent from the catalogue — this description potentially accounts for the presence of Jack Simons' gift hairbrush in the archive: it is an artefact able to give researchers some sense of Alexander's personal qualities and the nuances of her relationship with her husband. This aspect of the brushes, namely their associations with the closeness and mutuality of a long love relationship, establish them as unusual markers of the intimate within this archive.<sup>136</sup>

However, the presence of the utterly commonplace 'Structa' hairbrush, complete with its tangle of discarded hair, challenged and forced me to re-assess what I took for granted as the limits of what might be deemed 'archive-able' in the Manuscripts and Archives Department. Though I had encountered a random range of everyday artefacts in the 'museum objects' collection (a pink silk tie, an embroidered handbag, a wallet containing calling cards), all of them are old, so that despite the lack of provenance in some cases, they

---

135 This was confirmed by ex-trade unionist David Lewis, (personal communication, 27 November 2014).

136 It is interesting to compare the lack of acknowledgement of this aspect of the hairbrushes within the Manuscript and Archives Department finding aids with the insistence on the power of everyday artefacts expressed in Tammy Rae Carling's 'Archive of Feelings', discussed in Chapter Three and contextualised in terms of the queer archive by Ann Cvetkovitch in her eponomously titled book (2003). Also see her lecture entitled *The Queer Art of the Counterarchive* (Cvetkovich, A. 2012).

seem at least to fall into some recognisable category of antique artefacts from the colonial era. In contrast, the hairbrush is cheap, mass-produced, widely available, blandly contemporary and lacking in the gravitas imparted by commemorative engraving.

While some of its connotations may be identical to those discussed in relation to Simons' other hairbrushes above, two factors propel this brush into an anomalous position within the archive. Firstly, its extreme ordinariness, together with its lack of any commemorative quality ironically make it stand out. Secondly, there is its quality as an intimate item associated with personal hygiene. In reflecting on the life of those very close relations to hairbrushes, combs, Connor observes that, 'Combing is caught up in the creation, among humans, of the second life, or second body of clothing. Somewhere between a tool and a garment, a comb is a most intimate form of body furniture' (Connor, 2013:66).

The plastic hairbrush, as a specimen of 'body furniture', has certainly crossed some invisible taxonomical line, one that divides the sphere of things kept solely for their everyday, personal use value from the kind of artefacts made accessible to public scrutiny within an archival collection.<sup>137</sup>

The notion that this brush is in some way too intimate for the archive is given credence by the lingering presence of hair<sup>138</sup> in its bristles.<sup>139</sup> It could be argued that this inherently glamour-less human waste, made doubly dubious by its association with the body of a deceased person, might propel the artefact into a zone of interpretation emphasising abjection. In its mildly repulsive associations with both bodily waste and death, the hair on the brush might, as Julia Kristeva expresses it,

Show me what I permanently thrust aside in order to live. These body fluids, this

---

137 At least within this archival collection, since archives of the everyday are not unknown. A good example is the Mass Observation Archive at the University of Sussex (Mass Observation, n.d.).

138 The artist and academic Pippa Skotnes, too, has contemplated the significance of human hair in the UCT archive, this time a single straight grey hair that appeared in one of the hundreds of dictionary envelopes that form part of the Bleek/ Lloyd/ xam collection. Skotnes deduces that the hair belonged either to Lucy Lloyd or to Dorothea Bleek. For her its fascination lies in part in counter-posing its presence in the archive with that of a container of the Bushman informant //Kabbo's hair in the Pitt Rivers Museum, where it ended up after Wilhelm Bleek sent it to Oxford University in 1873 (Pippa Skotnes, email correspondence, 17 August 2015).

139 For some reason, perhaps because the other brushes were used less recently than this one, they are completely clean and hair-free, which emphasises their more commemorative aspect.

defilement, this shit are what life withstands, hardly and with difficulty, on the part of death. There, I am at the border of my condition as a living being ... Such wastes drop so that I might live ... (Kristeva, 1982:3).

However, this is not how the hairbrush presents itself to me. Things are slippery, abounding with a multiplicity of potential meanings. This point is well illustrated in Orhan Pamuk's novel *The Museum of Innocence*, in which, over a period of several years, the hero Kemal steals innumerable everyday items that have had anything to do with the unattainable Fusun, whom he loves passionately. These odds and ends are not confined to any particular category, but can literally be anything — he even steals Fusun's discarded cigarette butts, which his feelings transform from things usually considered revolting to things cherished and lovingly displayed. Referring to his collection as a whole, he explains, 'Sometimes I would see them not as mementoes of the blissful hours but as the tangible precious debris of the storm raging in my soul' (Pamuk, 2010:361). However, later he notes that,

I may not have won the woman I loved so obsessively, but it cheered me to have broken off a piece of her, however small. To speak of breaking off a piece of someone is, of course, to imply that the piece is part of the worshipped beloved's body; but three years on, every object and person in that house ... had merged with my mental image of Fusun (Pamuk, 2010:372).

Here, the meanings Kemal ascribes to his pilfered keepsakes are not fixed, but are able to shift to incorporate different stations along a broad affective spectrum. This multivalence could apply to any artefact, including the hairbrush.

The fact that the hairbrush is associated with a deceased individual adds another possible layer of meaning. According to Margaret Gibson, '... death and bereavement set in motion classifications of objects — sacred, profane and abject — in relation to shifting economies of value and meaning' (2010:56). In the destabilised arena of bereavement, the sacred and the abject, though 'morally and hierarchically' distinguished from one another, are in fact, in close relationship (Gibson, 2010:57-58).<sup>140</sup>

---

140 This means that, for example, the sacred religious relic beloved to many cultures cannot exist without the abject corpse, which they once formed a part of (Gibson, 2010:57-58).

Gibson makes clear that these shifts in classification of artefacts associated with a deceased person result in a multiplicity of possible responses:

Hair falling from the body without the intention and will of a subject is abject. Hair in the brush of a deceased loved one is abject to a stranger but not necessarily to those who know the source of the substance and who sacralize this body trace. Death can thus transform what is abject into something sacred (Gibson, 2010:58).

To the responses listed by Gibson can be added other possible reactions when the hairbrush is accessed by researchers within an archive, for example, the desire to learn more about its owner by analysing the hair scientifically.<sup>141</sup> In this case, revulsion or squeamishness becomes irrelevant.

Secondly, though admittedly the hairbrush is about as forlorn as an artefact can get to be, it seems to me to speak of more than death. Apart from its incongruity as a personal, intimate thing within the archive, for me what remains interesting is that, having entered the archive, the plastic hairbrush now boasts the status of an item worthy of custodianship and even scholarly attention. Thus its value has shifted, and this is only due to its association with the life of its owner as a first step.

Lastly, and on an entirely different note, for my purposes in this project, the brush and the hair caught up in its bristles provided me with a compelling metaphor for the process of entanglement within the archive, which I explored in an artwork of the same name.

### ***The artwork: Entanglement***

*Entanglement* is a 1.4 m long sculpture based on the plastic hairbrush in the archive. The body of the hairbrush is made from high density foam, spray-painted silver grey. Its bristles are wooden chopsticks ending in modelling clay 'bobbles', painted black, while the tangle of 'hair' unevenly entwined within them, which trail at random onto the floor around it, is made from six different coloured strands of thick wool. Though clearly this 'hair' is not real, something about its colours, texture and the way it falls is strongly reminiscent

---

141 This approach was suggested to me during the course of my research.

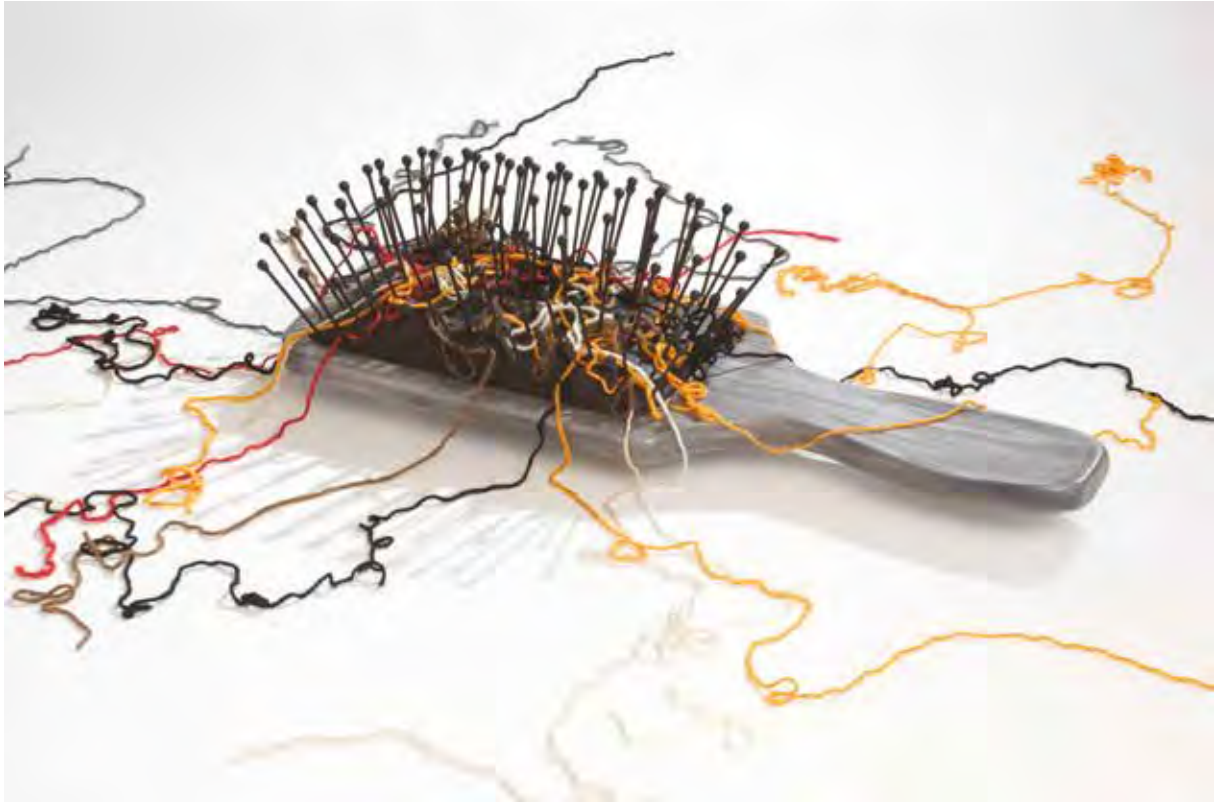

of (a scaled up version of) human hair, so that it plays on notions of naturalistic reproduction but at the same time resists them.

On *Slantways*, a small, clear perspex rectangular box that was all but invisible from the angles available to viewers raised the brush about 10cm off the ground, so that it appeared to be hovering above the floor, as if very slightly levitating. The artwork was positioned just to the right of the centre point of the gallery, so that visually it was the first work visitors encountered as they looked to their right on entering the room.

In terms of my practice, in its scale, this work was a departure, even an inversion, since most of my work prior to my PhD was based on miniature collected artefacts. As a giant version of a conventionally much smaller thing, *Entanglement* has many illustrious precedents. Most obviously, particularly if the domestic subject matter is considered, it resonates with many of the 'large scale projects' of Claes Oldenburg and Coosje van Bruggen, made between 1960 and 1995 for various outdoors sites in America and Europe. These huge public sculptures of everyday things range from a clothespin to a button, and from a trowel to a shuttlecock.<sup>142</sup>

---

142 In comparison to these works *Entanglement* is only modestly enlarged. Each of the four shuttlecocks, for example, is 5.45 m long (Oldenburg and van Bruggen, 1995:191).



In discussing the conceptual concerns informing these works, Oldenburg commented,

I am preoccupied with the possibility of creating art which functions in a public situation without compromising its private character of being antiheroic, antimonumental, antiabstract, and antigeneral. The paradox is intensified by the use on a grand scale of small-scale subjects known from intimate situations — an approach, which tends in turn to reduce the scale of the real landscape to imaginary dimensions (Oldenburg, n.d.).

While my own decision to scale up the brush was also made to underline its ordinariness, a crucial dimension of its production was the effort to mark its incongruity within the archive, and the desire to underscore that strangeness by giving the viewer no choice but to relate to it as something quite out of the usual experience of the thing called 'hairbrush'. A further motivation was to relate the sculpture to the concern with issues of sight loss that pervaded the exhibition as a whole. Like the enlarged wall texts and the disrupted scale in the golden artefacts of *Hoard*, the giant hairbrush alludes quite simply to the concern to make visible things that were/are difficult to see, both directly and symbolically in terms of my work in the archive.



Its scale aside, as mentioned above, the most pressing motivation for producing this work was the metaphorical possibilities it presented. As the title of the artwork suggests, the brush seemed to me perfectly to lend itself as a symbol of the entanglement that takes place both within the broadly conceived terrain of history, as well as more specifically within the confines of a physical archive.

According to Sarah Nuttall, the term 'entanglement' gesture[s] towards a relationship or set of social relationships that is complicated, ensnaring, in a tangle, but which also implies a human foldedness (Nuttall, 2009:1). Though Nuttall specifies that in South Africa the term has its greatest resonance in relation to race, it also 'brings with it ... other registers, ways of being, modes of identity-making and of material life' (Nuttall, 2009:2). These include the 'uneven mixing and reformulation of local and imperial concerns' (Nuttall, 2009:3). Furthermore, entanglement 'enables a complex temporality of past, present and future' (Nuttall, 2009:11), and can be used as a rubric to engage with the relationship between people and things (Nuttall, 2009:7) as well as more socially understood interfaces, such as 'the seam' put forward by Mostert and elaborated by De Kok as 'the place where difference and sameness are hitched together' (Nuttall, 2009:5).

At the level of one particular archive such as the Manuscripts and Archives Department, a complex of human conditions come together and become intertwined. Through accidents of birth and other vagaries of chance, the unfolding and interaction of personal and socio-political histories, and not least the predispositions of the archival gatekeepers, who decide which material does and which does not merit inclusion into this 'temple and ... cemetery' (Mbembe, 2002:19), multiple stories crisscross and interlace. While also alluding to, and in fact celebrating the peculiar presence of the plastic hairbrush in the archive, *Entanglement* was intended first and foremost as a metaphor for these multiple comings together, which are central to my understanding of the archive.

## Three performative pictures

### *The things and their people*

Early in my research process, it became clear that certain things owe their presence within the object collection entirely to their entanglement with famous historical figures.<sup>143</sup> I began to consider a counter-intuitive move: mostly, in terms of the interrogation of the entanglement of people and artefacts, things are conceived of as shedding light on the humans they are enmeshed with, rather than the other way round. Now, however, I imagined inserting myself into re-created versions of reasonably well known extant historical photographs of the famous individuals the things are associated with, as a means to access a selection of these things from a new perspective. My hope was that this approach would add both to my own and to an audience's sense of the collection, as well as challenge taken for granted understandings of the history the collected artefacts (and the photographs) relate to. This inversion seemed to accord well with my desire to approach my subject matter from unusual and unpredictable angles.

In January 2012, in collaboration with the Johannesburg-based photographer Mark Lewis, I produced a small series of works in which I re-enacted three existing photographs of key individuals associated with things from the collection: the wife of King George VI and mother to the current Queen Elizabeth of England,<sup>144</sup> Cecil John Rhodes and David Livingstone. In addition, as a means to refer to the collector responsible for assembling the object collection in the first place, I also asked Lewis to photograph me performing as R.F.M. Immelman at work at his desk in the Jagger Library at some time during the 1960s.<sup>145</sup>

I employed mixed media to produce the final images. In each image, a cut out photograph of myself performing the protagonist was collaged onto a pen-and-ink version of the original background. In keeping with the approach taken in *Hoard*, I made no effort to reproduce the scale of the original images

---

143 Apart from the pen and the record associated with Queen Elizabeth's visit to UCT in 1947, the Rhodes 'deathmask', the chip of wood associated with Livingstone's proposal to Mary Moffatt and the cloth addressed by Olive Schreiner, the list of these things includes the fragment of wood from the vessel 'the Fram' used by Nansen to try to reach the geographic North Pole, and Afrikaans poet C. Louis Leipold's belt.

144 As my attempt to perform the hyper-feminine Queen was unconvincing, I abandoned this work.

145 The original photograph was not dated.

faithfully, but instead made them to a scale at which it felt possible for me to draw with the limited vision that I now have. Also, I allowed the collage aspect to be quite visible in the images, so as to discourage overly literal readings of the new versions.

I also attempted to become the subject of the photograph, yet at the same time retain some elements of my own subjectivity. So, for example, I chose not to remove the rings I habitually wear, and these are clearly visible, particularly in the image in which I perform as David Livingstone. Also, importantly for the concern with this body of work to expose the issues I (and many others) confront relating to visual impairment, I included my spectacles in some of the photographs, and also made use of a magnifying glass in *Homage to Mr Immelman* — an element lacking in the original photograph.

Via these remade images, my intention was to raise a series of open-ended questions relating to the photographs' subjects, the structures that legitimated their subject positions, the persistent reach of colonial past into the present and my own as well as the viewers' relationship to that history. None of these questions had fixed or easy answers, with some of them actually contradicting each other.

## Homage to Mr Immelman

*Homage to Mr Immelman* was hung near the entrance to the gallery, immediately adjacent to the curatorial statement. This work is, in the first instance, quite literally what its name proclaims — an image (albeit a playful one) made to honour the person responsible for the existence of the Manuscripts and Archives object collection, in all its eccentricity, without which this project would not exist.

Obviously, though, in presenting a parodic re-imagined version of reality in which I 'become' Immelman, complete with a rather overly ornate and sumptuous gold frame, this artwork speaks of other things too. In discussing Joseph Roach's work, Colin Counsell refers to his

assertion that performance ... entails processes of remembering, forgetting and reinventing — of restating past values, dispositions and relationships via "surrogates," enacting new dispositions, and so on ... memory and meaning



are imminent in the act itself, generated and negotiated by particular bodies, specific acts (Counsell, 2009:7).

Here the focus is on re-inventing the photograph as a means to consider its original subject. One reading of my recreated image is that, by 'stepping into' the original photograph and performing Immelman at his desk, in the process bringing with me not only my female body and my disability but also my rather different set of sensibilities, dispositions and perspectives on South African history and the archive, I propose an alternative version of how the Manuscripts and Archives Department might have been. This new, imagined version of what happened then calls into question Immelman's own subjective understandings of the world he lived in, history and the archive.

The only actual material from the Manuscripts and Archives Department on the exhibition, three framed fragments of archival material relating to the object collection, were hung next to *Homage to Mr Immelman*. These were the envelopes in which the chip of wood and the pen had been kept for many years, complete with handwritten notes on their provenance, and a typed description of one of the artefacts from the collection, a miniature wooden rifle carved by a prisoner of war from the first South African War.

I chose to display these ephemera in three identical, golden frames as opulently decorative as the one used for *Homage to Mr Immelman*. On the one



hand, paying such elaborate attention to this textual material speaks playfully of Immelman’s love of his ‘treasures’; but it also serves to throw the archival convention, whereby such material is considered very much secondary to the actual collections, into relief and question its validity.

## Troublesome Ancestors I and II

### Archival things: the chip of wood and the Rhodes ‘deathmask’



In terms of Counsell’s formulation quoted above, one of the many possible choices in the re-enactment or re-invention referred to is that of interrogative disruption. In Nomusa Makhubu’s *Self Portrait* series, she performs various unnamed East and Southern African women pictured in existing colonial-era studio portraits dating from the period 1870 to 1920 (Erdmann Contemporary, n.d.).

Since Rhodes' and Livingstone's lives were lived at the very opposite end of the spectrum of colonial power, privilege and agency to Makhubu's subjects, there are major differences between the photographs she chose to re-enact and the original images of Rhodes and Livingstone into which I inserted myself. Within the overarching archive of historical photographs referred to by Sekula, the photographs of Rhodes and Livingstone fall into his category of a 'look down' to one's 'inferiors' rather than a 'look up' to one's 'betters' (Sekula, 1986:10). Certainly, neither Rhodes nor Livingstone would ever have been exposed to the profoundly dehumanising visual language characterising much of the photography undertaken in the colonies, so often concerned with the attempt to classify human beings in the same manner employed by Linnaeus for the natural world (Makhubu, 2013:1 and Landau, 2002b:142). Livingstone, in fact, requested his photographer brother Charles to 'secure characteristic specimens of the various tribes' in the interests of the pursuit of ethnological study (Ryan, 1956:152 cited in Landau, 2002b:144).

Nevertheless, despite these differences in the subjectivities expressed in the original photographs, there is one important similarity between Makhubu's performative work in her *Self-portrait* series and my own *Troublesome Ancestors I and II*. Just as Makhubu emphasises that her presence as 'conceptual agent' in these works '... subverts or at least questions structures of legitimation [and the] ... validity of one pervasive historical narrative as well as the authority of scientific (anthropological) study' (Makhubu, 2013:3), my own re-configured images are intended to disrupt seemingly unwavering dominant historical narratives, to ask questions and to propose new ways of conceiving of the past. These works, like Makhubu's, both '... *rupture* and *interrogate* predominantly masculine historical narratives' (Makhubu, 2013:abstract).

Their insistent iteration of the tropes of white colonial masculine dominion over the African landscape is a key element in the original photographs of Livingstone and Rhodes. My own challenge to these narratives occurs in the first instance through the parodic act of cross-dressing I undertake as I endeavour to re-play Livingstone's lugubrious, yet somehow self-satisfied posing with a kudu horn, and Rhodes' sour-faced torpor as he lounges haughtily in the veld, with the evidence of the mining activity in the distance behind him that, while it made him an immense fortune, was to have dramatic and painful effects on the social fabric of Southern Africa.



For Van Wolputte,

Irony, parody, memory, moral imagination, and narrative ... can be considered processes (and technologies) of self. Revolving around embodiment, they involve “individual” experience, but also, “always-already,” imply intersubjectivity (2004:260-261).

In my insertion of my own female body into the role of colonial overlord, there are echoes of Yinka Shonibare’s *African Dandy* series. In this series of five photographs, the artist humorously but pointedly troubles the usually rock-solid tropes of British aristocratic privilege by playing the central role of the Dandy, surrounded by ministering servants at different moments in the course of a day. In the case of this series, it is the artist’s race rather than his gender that forces a double take on the part of the viewer: Shonibare’s ‘... body alone suffices with its difference and incongruity to create a short-circuit in the more profound sense of this reassessment’ (Perella & Di Majo, 2001:58).

The obvious danger in this kind of performative work is that, instead of challenging the hegemonic narratives of colonial conquest and domination, the work will simply reiterate them. Makhubu suggests that one key to

allowing disruption rather than re-iteration to prevail is to access a different, non-Western, non-linear temporality. In her conception, time is understood to be labyrinthine — ‘a maze which one finds oneself walking in and out of’ (Makhubu, 2013:5). With this conceptual shift, ‘... the appropriation of tropes of the past can be a powerful weapon that interrogates past and present repressive structures’ (Makhubu, 2013:5).



Similarly, Ariella Azoulay explores the idea of viewers approaching the temporalities represented in photographs as though the bodies pictured therein exist in a coterminous presence. According to Laura Levin, Azoulay proposes

... complicating the traditional distinction between, on the one hand, the photograph “as an inert, mechanically reproduced image” (Gilbert 1998: 21) that documents the past and, on the other hand, performance as the terrain of liveness and the continuous present’ (Levin, 2009:330).

For Azoulay this approach implies the enabling of a different, more active ethical relationship between the viewer and the image viewed (Azoulay 2008:16 in Levin, 2009:330).

The application of a more complex and fluid approach to temporality allows these re-created images<sup>146</sup> to open up a second layer of meaning, namely their attempt, via one re-imagining of an alternative past, to make an oblique allusion to the alternative future that might have been the result of a different

---

146 At least on the part of the artist — there can obviously be no control over how viewers apprehend these images.

history. Writing about German theatre, Walter Benjamin makes the point that,

Although the economy of representation within which the theatre operates consigns mimesis to the re-presentation of past events, *it also reanimates their latent potentiality as missed opportunities to construct an alternate vision of future possibilities* (Benjamin 1985:109 in Kear, 2006:149 — my emphasis).

In keeping with this notion of the imaginary consequences of a tampered-with history, in these collages, firstly via my cross-dressing and also via the traces of my own embodied persona (for example my rings in the image of David Livingstone), my aim was to use traces of my 21<sup>st</sup> century subjectivity to suggest that it is possible from our temporal vantage point to refer to the question of what contemporary South Africa might have been like had our violent and repressive colonial history been different. This reinforces a similar intention in the artwork *Translation I: The Queen's Speech* (see below).

On an entirely different note, despite the satirical quality of these images, which do not disallow a light-hearted response, impersonating Rhodes and Livingstone was not comfortable and was never intended as a flippant gesture. Instead, my impersonation of Rhodes and Livingstone alludes to the likely (though in the details unknowable) complicity of my own (blood relation) forbears in the power relationships of the colonial era; so that from a contemporary perspective, the photographs speak both of the impossibility of entirely burying the colonial past, as well as the complicity of white South Africans and therefore the guilt, even if disavowed and seldom acknowledged, of their contemporary descendants.

However, this intention is only one aspect of what I am trying to propose with the re-animation of these historical figures. From a different perspective, though their reduction to one-dimensional cartoon villains during the liberation struggle was politically appropriate and necessary, with these works, I am proposing that a more complex engagement with them is now apposite.

This is by no means an effort to deny the inhumanities perpetrated in particular by Rhodes, as well as those who succeeded him, in the name of British imperial greed, and the ongoing effects of these policies and actions well into our own time.<sup>147</sup> Rather, it is to underscore this truth, which amounts to

---

147 Nor is it to criticize the removal of the Walgate sculpture of Rhodes from its problematically prime position



the existence of what Dodd calls the ‘zombie aspect to the Victorian political inheritance in Africa’: a ‘gangrenous body ... [that] ... continues to live, haunting the carved-up landscape, spasmodically influencing the political and social realities of the day’ (2014:76).

In other words, no matter how Imperialist figures like Rhodes and Livingstone are now regarded, it is impossible to ignore the fact that the post-colonial and post-apartheid South Africa of today is built upon and amongst the ruins of their imperial dreams. If, as Stoler asserts, ‘ruination is a corrosive process that weighs on the future and shapes the present’ (Stoler, 2009:194), it is too crude simply to loathe, dismiss or disavow figures like Rhodes, as was the case in the apartheid era, when the urgency of the pursuit of national liberation demanded that analytical subtlety strategically be set aside. In the current era, such historical figures require speculative critical engagement;<sup>148</sup> so that this work, together with the Rhodes ‘undeathmasks’, represents an attempt to approach his far-reaching and disturbing legacy in a spirit of creative enquiry.

---

on UCT campus in response to the Rhodes Must Fall Campaign (See Conclusion).

148 Perhaps if debate on the contentious presence of the Walgate sculpture of Rhodes had been encouraged on UCT campus over the past 20 years, the Rhodes Must Fall campaign of 2015 might not have needed to take place.

## The Rhodes ‘undeath’ masks

### Archival thing: the Rhodes ‘deathmask’



#### *The ‘thing that hovers’*

While Ray Alexander’s plastic hairbrush appears as an anomalous inclusion in the archive, the political status of the person it is associated with in post-apartheid South Africa is assuredly positive. In marked contrast, the unlovely and unloved item known as ‘the Rhodes deathmask’ is located at the very opposite end of the South African political spectrum in terms of who is now considered worthy of remembering — and would also surely vie for first prize in an imaginary contest for its sheer incongruity in the archive.

Arguably, the presence of any such mask that has somehow ended up forgotten in a university library archive, even one representing the face of a more anonymous individual, might seem bizarre.<sup>149</sup> However, the fact that this mask is understood to have been cast from the dead face of the infamous arch-imperialist Cecil John Rhodes only adds to the sense that it is somehow misplaced in the Department.

This sense of reasonably absurd dislocation in no way fully explains the curious impression that a multitude of possible meanings — all of them somehow elusive, some of them positively contradictory — emanate from this inscrutable artefact. In fact, instability of meaning seems to be its chief

---

149 In fact, the Rhodes ‘deathmask’ in the Manuscripts and Archives Department is not the only deathmask in a university archive, as I discovered when, in September 2013, the Bodleian Library at Oxford University displayed what is described as ‘the supposed deathmask of Dante’ on a one-day exhibition held to coincide with the conference ‘The Lives of Objects’ at Wolfson College. The difference, though, is that this ‘deathmask’ like all the artefacts held at the Bodleian relates to a famous writer (The Conveyor, 2013).

characteristic, so that it perfectly exemplifies Brown's understanding of the thing (as opposed to the object) outlined in Chapter Two — an item that embodies '... a certain limit or liminality, hover[ing] ... over the threshold between the nameable and unnameable ...' (Brown, 2004:4-5). The mask, in the best tradition of 'thingness', is 'a paradox incarnate' (Daston, 2004:24).

Most obviously, as a relic that entirely lost its value as the years passed, corresponding to a posthumous personality cult that ultimately transmogrified into almost its opposite, an unstated but determined disavowal, the mask speaks volumes of how perceptions, and with them readings, of the archive have transformed over time.

Secondly, deathmasks obviously speak of centuries of funerary rituals and practices put in place to preserve memories of the dead. A death mask produced in South Africa in the early 1900s would almost certainly have been associated with a particular European and British tradition, popular in the late 19th and early 20th Centuries, for the most part long abandoned. Here there is an added association: though there is no evidence that this particular mask was produced in the pursuit of knowledge, casts of the human face and head made at this time inevitably also call up the pseudoscientific fantasies of phrenology, which purported to expose links between the facial features, the shape of the skull and the personality.<sup>150</sup>

Further, since a deathmask is by its nature a thing that straddles the divide between the corporeal and the hereafter (whatever that term is understood to imply), it refers both to the mysteries of life and death and the transition from body to corpse, that bizarre '... object that is a border ... between I who expel and that which I expel ... between the pure and the polluted ... between subject and object' (Kristeva, 1982, quoted in Schwenger, 2006:157).

Here, however, it becomes necessary to pause; because quite overshadowing all of these co-existing narratives is a surprising revelation that turns several of them on their heads — the story of a fundamental error in interpretation and cataloguing, one that appears to have been in place for the past 50-odd years. The fact is that, despite the way it has always been

---

150 Phrenology was developed in the 18th century by German physician Franz Joseph Gall, whose collection of the skulls of criminals and the insane, as well as cast heads and death masks of both the criminals and the celebrities of his day, is on display in his home town of Baden (Blom, 2002:98-100). Interestingly, the Manuscripts and Archives Department also contains a phrenology kit, consisting of a very worn cardboard model of the brain, and a pair of callipers, now missing.

understood in the Manuscripts and Archives Department, a close engagement with this artefact convincingly shows that it is not actually a deathmask at all.

This revelation, which seemed ruthlessly to whip the carpet out from under my feet, initially provoked in me a mild epistemological panic attack, seeming to cast doubt on the entire collection. Anxiously I asked myself what it would mean if Ray Alexander's hairbrush had in reality belonged to a visiting friend, or the chip of wood was actually a remnant from the floor of a carpenter's workshop, or if Immelman had really donated an entirely arbitrary pen by mistake, one untouched by the venerable hands of the Queen when she visited UCT in 1949. After some time, though, these concerns subsided. It became clear that the mistake which had never been rectified had not randomly befallen this particular item.<sup>151</sup> Instead, the fact that it represents the face of Rhodes, as well as the fact that it has always been understood to have been his deathmask, have both played their part in allowing the error to go undetected.

### ***The hero worshipper's relic***

Almost no information is available with regard to the provenance of this artefact. All that is known — and it is not inconceivable that this information is incorrect — is that it entered the Department in 1963 as part of a personal collection of 7057 items, including a range of 'Rhodes-eana' — papers, letters and various other material relating to Rhodes, donated to UCT by Cecil James Sibbett, who died four years later. There is no hint of its back story<sup>152</sup> — its 'life' before it entered the Manuscripts and Archives Department (Hamilton, 2011:319-341). Whether it was loved and revered, as presumably it would have been if it was in Sibbett's possession (see below), or whether it lay forgotten in a drawer or cupboard, is impossible to say.

According to the catalogue, Sibbett emigrated from Belfast with his father in 1897, at the age of 16. Soon after his arrival at the Cape, he joined a local branch of the South African League, an imperialist political organisation presided over by Rhodes. The catalogue notes that

---

151 Though it does serve as a reminder that there is plenty of room for errors to go un-noticed within archive, often over long periods of time.

152 See Hamilton (2011) for a discussion of this concept.

This association with Rhodes, which is an abiding and dominant theme of Sibbett's life, was strengthened when, in the years 1901–1902, he became Rhodes's assistant political secretary, and after his master's death, he strove to keep alive the memory of Rhodes, whom he had on his own admission, hero worshipped (CJ Sibbett Papers).<sup>153</sup>

In its current archival setting, the mask is kept wrapped in a sheet of crumpled newsprint in the lid of an old A4 paper box. On first sight, it has an undeniably compelling, if somehow disturbing, presence. To put it plainly, it exudes a certain unnerving, creepy quality. This seems slightly at odds with its fragility — cast from plaster of Paris, it tends to crumble at the edges, no matter how much care is taken in handling it.

The mask is in poor condition. A section below the chin has cracked, but has been repaired from behind, so that the crack is not visible. There is also a sizeable chip missing from the left-hand edge of the forehead. It is stained brown, though quite unevenly — this stain might be a finish applied at the time the mask was cast, or it may simply be the patina developed over the long years of its existence.

Further damage is visible in the form of three roughly parallel long, vertical lines running the length of the left-hand side of the face (the right-hand side of the mask as one views it). These lines curve slightly with the contours of the face. They start from an indentation on the left-hand side of the forehead, run down through the left eye and the cheek, and end below the chin. Though these lines at first look like scratches, they are more likely to have been etched into the mask by some kind of acidic liquid that dripped onto the top of it and ran down its surface — evidence that, at some stage in its history, this mask did hang on a wall (Verna Jooste, personal communication, 26 June 2012). Further confirmation is provided by the neat hole drilled into the top of the forehead.

The fleshy, jowly and slightly sagging features are those of an older man, and the bushy eyebrows and moustache somehow add to the mask's macabre quality. Paradoxically, though, its most disconcerting aspect is its half-open eyes, which look slightly glazed and absolutely lifeless, like those of a dead

---

153 In the context of conjecture about Rhodes's sexual orientation amongst his biographers, it seems quite possible that Sibbett's 'hero worship' of Rhodes was the acceptable expression of stronger, far less socially permissible feelings that, during his lifetime, he felt compelled to suppress.

animal or fish. Although the mask differs in this regard from the other Rhodes 'deathmasks', both in Cape Town as well as in London and Bulawayo,<sup>154</sup> all of which have closed eyes, these open eyes do not provide conclusive evidence that it is not a deathmask. While the danger of injury would not allow for the subject to keep his or her eyes open while a mould is being made, it is quite possible to make one with the eyes closed, and sculpt open eyes at a later stage. The fact that the mask does differ from the other Rhodes masks in this way did, however, arouse suspicion, serving as a first intimation that the UCT 'deathmask' might be something else altogether.

### ***Spotting the difference***

Only the following information is given in relation to the mask, in a separate catalogue listing the photographs and memorabilia attached to the collection:

Rhodes died at his cottage in Muizenberg on the evening of March 26 1902. Among his close friends who were called to the cottage that night was Dr Smartt.<sup>155</sup> At his instruction, a mask was made a few hours after his death. The mask is 12" high (CJ Sibbett Papers).

It is not clear when this catalogue was produced, who compiled it, and from where this information was obtained.<sup>156</sup> Presumably, the fact that various sources refer to the taking of a mask at the time of Rhodes's death influenced the construal of the mask as a deathmask when it arrived at the Manuscripts and Archives Department in 1963.<sup>157</sup>

One such source is Jourdan's 1911 biography of Rhodes, which notes that a deathmask was cast on the night of his death, while his body was still at his cottage in Muizenberg (Jourdan, 1911:271). The New York Times

---

154 These include the mask in the bedroom cupboard at Groote Schuur, Rhodes's former home, and the one in the Cape Town Club. The mask in London is housed in the National Portrait Gallery, and another mask is held in Bulawayo at the National Museum of Zimbabwe.

155 According to the Archives of the University of the Free State, Sir Thomas William Smartt was a Member of the Cape Parliament [1893–1910]; Unionist Party MP Fort Beaufort [1910–1920]; South African Party MP Fort Beaufort [1920–1929]; and Minister of Agriculture [1921–1924].

156 According to information supplied by Isaac Ntabankulu, who works in the Manuscripts and Archives Department, the Sibbett collection was only processed in 1979, at the time when Leonie Twentyman-Jones headed the department (Ntabankulu, personal communication, 20 March 2012).

157 Although it does seem curious that Sibbett would not have known the mask's true origins and elaborated on them at the time of the donation.

report on Rhodes's death also refers briefly to a deathmask. Under the heading 'The "Empire Builder" Passes away peacefully', the report gives a thorough description of the deathbed scene, noting that 'all his "boys" and personal servants were admitted at the last'. After outlining elaborate funeral arrangements, it notes that: 'The features of the dead man are placid, and a death mask will be taken' (The New York Times, 1902).

While the existence of these sources may provide an explanation for the error in the cataloguing of the mask, there is also an alternative possibility. Sylvia Quinn, who headed the UCT Acquisitions Department from 1958–1960, recalls that

... the deathmask was greyish in colour, and had closed eyes. I had to pass it every day, because it hung in the passage on the way to the sub-librarian's office, the staffroom and a few other offices. I remember thinking "what an unpleasant object to have on display here!" (Sylvia Quinn, personal communication, 3 July 2012).

Quinn's recollection is curious for two reasons: firstly the current 'death mask' has open eyes, and secondly, the mask in fact only came into the Department in 1963, after Quinn had left. This might indicate that, at some point during the many alterations that took place in the Library over the past 40-odd years, the current 'deathmask' accidentally came to stand in for a previous, more authentic version that somehow disappeared.<sup>158</sup> On the other hand, though, the inconsistency may simply indicate that memory is fallible, or alternately that, at a time when painstaking attention to provenance was not yet emphasised in the archive, mistakes in cataloguing were bound to happen.

The vital clue confirming that the Manuscripts and Archives mask is not a deathmask is to be found in the cause of Rhodes's death, given as 'two successive attacks of heart failure' in the New York Times report (*The New York Times*, 1902). According to Rotberg, though Rhodes was only 48 when he died, '... the ballooning of his aorta, which progressively restricted the return of blood from his head and upper body, transformed the lithe figure into someone

---

158 This would have to have happened before 1975 — Leonie Twentyman-Jones, who headed the department from 1975 to 1995, is adamant that by that time the current mask was known as 'the Rhodes deathmask', and was kept in a box rather than hung on a wall (Leonie Twentyman-Jones, personal conversation, 4 July 2012).

swollen and prematurely grey haired' (Rotberg, 1988:680). In keeping with this description of the effects of his illness on Rhodes's face, the faces of the National Portrait Gallery in London and National Gallery of Zimbabwe masks are noticeably bloated. In contrast, though the UCT mask certainly does not show the face of a man in the first bloom of youth, it is visibly thinner and not noticeably swollen. In fact, it looks nothing like the mask referred to above.

### ***The plot thickens***

Far from clarifying the question of the provenance of the UCT-based mask, research conducted into the other extant Rhodes death masks only served to expose further mysteries. Firstly, while facial hair is clearly visible in Internet images of the masks held in Bulawayo and London, the mask kept in pride of place in the glass-fronted cupboard in Rhodes's bedroom at Groote Schuur shows a smaller, less swollen face, shaven clean of moustache and eyebrows, with rather different facial features. Whoever this is, it does not seem to be Rhodes.

The mask hanging at the Cape Town Club also looks different. While the staff at the club gleefully speculate that theirs is the mask stolen from Rhodes' cottage in Muizenberg, the obvious difference between their mask, and images of the authentic one hanging at the National Gallery make this seem very unlikely: the Cape Town Club mask is black and has a subtly harsher look about it. The face is also a slightly different shape, and neat hair is in place. Like the UCT mask, this is very unlikely to be a deathmask. To confuse matters further, there is no information available on the provenance of either the mask at Groote Schuur or the mask in the Cape Town Club. Finally, an undated photograph held in the South African library shows yet another, subtly different mask, this one with facial hair intact but with a seemingly less swollen face. The back of the photograph gives the address of an English photographic studio, but the image is not dated.

### ***The cult of Rhodes***

One explanation for these puzzling discrepancies may lie in the cult of Rhodes that developed in the years immediately after his death. Despite the damage caused to Rhodes's reputation by the Jameson Raid, he retained some

degree of popularity and his death was publically mourned on a grand scale (Maylam, 2005:116-117). The *New York Times* report of the event ended with a description of the 'profound grief' caused by the news of his demise as it spread through the city: 'All places of amusement were immediately closed. An open air concert was stopped, and the audience uncovered while the band played the Dead March. The people then silently dispersed' (The New York Times, 1902). Over the Easter weekend of 1902, Rhodes's body lay in state in Groote Schuur, during which time 45 000 mourners filed past it. Two state funerals were held, one at Groote Schuur and one at the Cathedral. There followed a five-day long funerary procession by train through Southern Africa via Bulawayo — where another funeral service was held — to the site of Rhodes's grave in the Matopos. The train stopped at many stations along the way, where thousands more mourners paid their respects. On the day of the actual burial, a memorial service was held at St Paul's Cathedral in London, attended by the leading lights of the British ruling classes (Maylam, 2005:32-33).

Given momentum by the scale of this extremely comprehensive and immeasurably grandiose funeral, as well as by the symbolic significance of Rhodes's final resting place, a cult developed from almost the instant of his death (Maylam, 2005:118). Perhaps the making of the deathmask can even be understood to have signalled the onset of this cult, which, according to Maylam, thrived until the centenary of his birth in 1953, after which it diminished and finally fizzled out along with the era of colonialism (Maylam, 2005:122). Although the erection of scores of public memorials and statues, most of them still in place to this day, was the most obvious feature of the cult, it was the determined and persistent efforts of various acolytes, powerful friends and admirers that enabled it to thrive for as long as it did. Interestingly, though the list includes names such as Leander Starr Jameson, Alfred Beit and Rudyard Kipling, it was Cecil Sibbett, nicknamed 'The Remembrancer', who over a period of 30 years was the chief mover behind efforts to have Rhodes's birthplace in England and his Muizenberg cottage declared as museums, and is understood to have been the cult's most tireless advocate (Maylam, 2005:128).

In this atmosphere of sentimental veneration, it is conceivable that the deathmask format became a fashionable means of portraying and commemorating Rhodes, with the reference to his face in death intended as a sign of great solemnity and reverence, and of the perceived tragedy of his early

demise. Though this may seem macabre to contemporary observers, it has to be remembered that at the time of Rhodes's death, prevailing attitudes towards the corpse differed greatly from the squeamishness generally displayed in our own culture.<sup>159</sup> In his biography, Jourdan dwelled at some length on the dead face of Rhodes:

There he lay undistressed and inanimate. The light fell fully on his Caesar-like face, and showed off his strong features and massive head to great advantage. I thought I had never seen him look more beautiful. His roman features were more pronounced than I had ever seen them in life, and he reminded me so much of the pictures I had seen of Napoleon Bonaparte. Even in death he looked determined, dignified and masterful (Jourdan, 1911:270).

In keeping with this reverential attitude towards the body at the time of death, during the Victorian era both deathmasks and other images of the dead face were a popular expression of the desire to commemorate celebrated as well as lesser-known individuals. It was not uncommon for hair from the deceased subject's head to be incorporated into the frame of photographic portraits of dead subjects (Batchen, 2004). The popularity of such practices is evidenced by the circumstances prevailing at Victor Hugo's deathbed 17 years before Rhodes's death, when 12 artists, including a sculptor, a painter and a photographer, were present. After Hugo's death, a deathmask was also made (Musée d'Orsay, 2006).

### ***From Relic to Reject***

I first came across the Rhodes 'deathmask' in early 2011. Despite its curiosity value, the mask was not introduced to me with anything close to a flourish. Instead it was revealed in a peculiarly offhand, even slightly embarrassed way, as though it was obviously lacking in any interest. It even crossed my mind that it was only shown to me because I happened to notice its box, and ask what it contained.

Initially I was confused as to the implications of this attitude to the mask; but after some time I decided that since it was obviously considered to be one

---

159 A squeamishness witnessed for example by the controversy that raged in England in 2010 when Daphne Todd's 'Last portrait of Mother', portraying her mother's dead body, won the B.P. Portrait Prize.

of the more dubious assets of the department, it was taken for granted that my own reaction to it would be negative, an involuntary shudder of repulsion in response to its morbid aspect, intensified by the contemporary South African aversion to and disavowal of Rhodes himself and what he, with hindsight, represents. In this regard it became clear that, in terms of this sense of disavowal, the mask stands in metonymic relation to the 'Rhodes-eana' of the Sibbett collection.

In terms of the issue of repulsion, to the extent that casts of human body parts are indexical signs, they are commonly perceived to be synonymous with the body itself, and even understood to be embalmed remains (Brenda Schmahmann, personal communication, 21 June 2012, and Schmahmann, 1998:14). This generally creates a certain visceral response to such artefacts; and this may well be even more marked in the case of deathmasks, at some level likely to be confused with the dead face itself. The fact that the Rhodes 'deathmask' is not actually a deathmask has no bearing on this response, because nobody at UCT ever realised that it was anything else.

By the 1970s, the universal sense of aversion to the 'ugly old thing' (Gerald Quinn, personal communication, 3 July 2012), inspired by its perceived close relationship to a dead face could only have been intensified by the fact that the face was thought to have belonged to Cecil John Rhodes, whose popularity at UCT was by then on the decline. This attitude grew stronger in the following decades.

However, as the Rhodes Must Fall campaign of 2015 attested, not all traces of Rhodes were rooted out at UCT. According to Schmahmann, writing about the pre-2015 period, while both Rhodes University and UCT have had to contend with 'troublesome inheritances' of Rhodes sculptures and busts, in the post-apartheid era UCT chose to deal with its sculptures of Rhodes in a low-key way, intended to allow for criticality and a degree of anti-Rhodes sentiment, which materialised fairly infrequently (2009:26). Schmahmann describes the incident in which students defaced the Walgate sculpture of Rhodes in 1981, a sign that by that stage he was no longer held in high esteem by everyone associated with the university (Schmahmann, 2009:23). Clearly, the more recent 'Rhodes must Fall' Campaign, culminating in the removal of the statue on 9 April 2015, adds a new dimension to this history, and perhaps — but only

perhaps — a finale.<sup>160</sup>

In a very similar way, the value ascribed to the 'Rhodes-eana' within the Manuscripts and Archives Department underwent a decline that accorded with alterations in the public perception of Rhodes over the course of the 20<sup>th</sup> century outside of the Department and the university, though in this case the change was slightly less visible. Though, according to Maylam, by 1963, when the Sibbett papers were donated to the Manuscripts and Archives Department, the cult of Rhodes was definitely waning, for many years, cartoons and photographs from this collection as well as several busts of Rhodes were prominently displayed around the library (Leonie Twentyman-Jones, personal communication, 4 July 2012). Then, as public perceptions of Rhodes were further devalued with the intensification of the struggle for democracy from the early 1970s onwards, within UCT the 'Rhodes-eana' previously so prominently displayed gradually lost its status, and ultimately slipped out of view altogether (Leonie Twentyman-Jones, personal communication, 4 July 2012).

As for the 'deathmask', though there is no evidence to suggest that it was ever particularly venerated or even liked at UCT, and though as an artefact rather than a manuscript or other textual material it was accorded a lower status in the department (Gerald Quinn, personal communication, 3 July 2012), it was certainly displayed on the wall. Now it became a slightly embarrassing reminder of a hated figure from South Africa's ugly, tainted past. In addition, its undeniable unattractiveness and the fact that it carried unpleasant associations of its (imagined) one-time proximity to a corpse must certainly have added to the desire to pay it no attention, to forget about it, in fact to hide it away. By 1975, it was relegated to a cardboard box, from which it has never emerged.

### ***Artwork: The Rhodes un-deathmasks***

This series consists of six faux deathmasks of varying sizes, made from a variety of different, aesthetically unmatched (in fact arguably visually incompatible) materials.

The first, though quasi-realistic in that it to a degree resembles the real Rhodes deathmask housed in the National Gallery in London, is improbably

---

<sup>160</sup> See the Conclusion for a detailed discussion of the ways in which this campaign intersected with my PhD project.





large. It is made of modelling clay spray-painted a yellowish white. The second, more of an appropriately human size, is made of modelling clay and covered in dazzling fake diamante; while the third, made of garishly bright orange, green, blue and red plasticine, and displayed beneath a perspex dome reminiscent of those covering funeral wreaths, has protuberant open eyes, and is improbably small, about the size of a six-month old baby's head. The fourth, which is slightly bigger again, is produced from a children's product known as 'crazy clay'. It is red, white and blue, and has a bulgy, rubbery feel, while the fifth, a miniature black mask made from modelling clay covered in shoe polish and placed on a crude, chunky brown plate is comical in its tininess. Finally, the sixth more-or-less life size mask is made from papier mache. On the surface, each paper strip presents a different name, including my own, torn from the Cape Town telephone directory, in acknowledgement of the complicity via ancestry (whether accepted or not) of the current generation of white South Africans in the oppressive history of the country.

The variety of approaches I took in the production of these masks and their consequent quite marked differences were intended to refer to the range of fake or would be masks staking their claims as real Rhodes deathmasks, as described above. My use of widely different materials for each mask was intended as a playful allusion to the vicissitudes to which Rhodes' reputation has been subject over the years, reflected to some degree in the way that the mask has been

valued within the archive since its donation in 1963, as outlined above.

To further highlight these swings in fortune, I chose to display the six masks on six separate black rectangular shelves, all at different heights, along the long southern wall of the gallery. Though the shelves were evenly spaced, their heights varied unpredictably and a-symmetrically. It seems worth noting that, had this work been exhibited only seven months later, after the events of the Rhodes Must Fall campaign, I may well have felt it appropriate to include an altogether empty shelf.<sup>161</sup>

More broadly, this work comments on the uncertainties of the archive, asserting that its holdings are not accorded a stable value over time, but rather have differing effects and are understood and treated differently according to numerous factors, ranging from the politics of the day to the dispositions of those entrusted with their care.

## Musa Askari <sup>162</sup>

### Archival thing: the chip of wood



Nothing could be more modest in its commonplace materiality than the 3cm long block of hard, dark, unevenly shaped wood in the Manuscripts and Archives object collection. Although it is not listed in the Museum Objects catalogue, the following explanatory note appears on the front of the white envelope in which it has always been kept, written in the hand of Immelman's

---

161 In other words, after the removal of the Walgate sculpture of Rhodes in accordance with the initial demand of the campaign, it may well have felt appropriate to comment on this final plunge in Rhodes's status to its lowest possible point — a total absence.

162 While the term 'askari' originally referred to an African colonial soldier, it was also used in the colonial era to refer to a servant. Later, in apartheid South Africa in the 1980s, it came to denote an ANC member who had turned informer with the South African Police force. (Whats in a Name? A Brief History of "Askari". 2014)

secretary, Etaine Eberhard:

This chip of wood is from the [~~wild olive~~] (scratched out and replaced by) almond tree under which David Livingstone is said to have proposed to Mary Moffat. 1844. Donated by R.F.M. Immelman, who purchased it from the Kimberley Museum.

David Livingstone was engaged to Mary Moffat in May 1844, when he was 31 and she was 26. Their marriage took place the following year. The trunk of the almond tree under which the proposal took place and from which the chip of wood was evidently gouged is still to be seen at the Moffat Mission Station at Kuruman, started by Mary Moffat's father Robert on behalf of the London Missionary Society (L. M. S.) in 1824.

The story of Livingstone's proposal under this tree in May 1844 is well enough known to have become, in later years, the stuff of online enticement to tourism in the Northern Cape. According to one website,

The original mission buildings still stand, surrounded by irrigated fields and shaded by magnificent trees, including giant syringa trees, pear trees, figs, pomegranates and almond trees. The trunk of almond tree under which David Livingstone proposed to Mary Moffat, now cast in a concrete foot (Sybren Renema, email correspondence, 21 February 2013) still stands in an overgrown garden (SA Travel Directory, 2012).

### ***The Livingstone trees***

From around 20 years after Livingstone's death, until well into the 1930s, a robust global trade was conducted in different-sized pieces of wood from this tree. One example is the large chunk held in the archive of the David Livingstone Centre in Blantyre, described as being 'about 50cm high and 30cm wide' (Alison Ritchie, personal communication, 13 January 2015).

Furthermore, sections of various sizes from other trees associated with Livingstone's life were also in circulation, for example, wood from the *mvula*<sup>163</sup> tree under which his heart was buried in Ilala, Zambia in 1873,<sup>164</sup> and the

---

163 Also known as the mpundu or myongo tree.

164 According to online information provided by the Hunterian Museum in Glasgow, Livingstone's grandson, Hubert Wilson, donated a slice of this tree that he had been given to Anderson College where Livingstone

baobab tree under which his wife Mary was buried in Shupanga, on the banks of the Zambezi River in 1862 (Livingstone, 2014).<sup>165</sup> Thus, the chip of wood's broader provenance — the claim that it was cut from the famous almond tree at Kuruman — is perfectly within the realm of possibility.

### *Immelman's relic*

However, exactly how the chip of wood came to be in Immelman's possession remains mysterious. Although his daughter Jeanne speculated that since his family home was at Kuruman, he may simply at some stage have decided to extract the little block of wood from the tree trunk with a penknife (Jeanne Cope, personal communication, 23 April 2011), in light of the trade in these relics as well as the information on the envelope, it seems more likely that it was bought. As for why he donated the chip of wood to the archive, another of his collecting enthusiasms, that of collecting handwriting specimens of famous people,<sup>166</sup> provides an important clue to his motivation, namely, the desire to venerate celebrity and celebrities.

As Gibson points out, the collecting of celebrity relics indicates '... a belief in an immaterial essence or aura which is nevertheless materialized and enduring in a body fragment or an object which has had contact with a body' (Gibson, 2010:157). To the extent that the pieces of wood were associated with the most celebrated British imperial explorer, for their collectors they were relics made potent by their associations with celebrity; and the desire to preserve something of the aura of the renowned colonial explorer within the archive must have inspired Immelman to donate this particular piece of wood.

---

had studied medicine. This slice of wood was moved to the museum in 1992 (The Hunterian, n.d.).

165 The Livingstone Centre also holds 'a fair number of other sections and pieces of various trees (such as the mango tree under which Livingstone met Henry Morton Stanley in Ujiji, Tanzania, or the tree under which his heart was buried in Chitambo in Zambia) (Alison Ritchie, email correspondence, 13 January 2015).

166 In 'The library of the University of Cape Town (1956), Immelman notes that '... the library has many single documents and letters, written by or to famous people.' The long list of non-South Africans includes Robert Graves, Rudyard Kipling, HG Wells, Christopher Wren, Whistler David Garrick, Queen Victoria and Henry III of France. (Immelman, 1956: 77-78). Lesley Hart points out that the collecting of single specimens of handwriting, which seems to have been a common practice under Immelman, is nowadays no longer considered sound archival practice (Lesley Hart, personal communication, 20 January 2012).

## ***Other meanings***

With the 50-odd years that have elapsed since the chip of wood came into the archive, it has gained further layers of meaning that overlay (though do not entirely obliterate) its quality as a relic.

Firstly, there is something old fashioned and polite about this relic when contrasted with the tasteless and sometimes ruthless celebrity collecting that is now indulged in the name of commerce and in some cases, art — such as the sale of Britney Spears' used chewing gum on eBay for \$14 000 in 2004 (Business Insider, 2011), or Barton Benes' artwork made from shards of glass collected from the scene of Princess Diana's death (Benes, 2002:43).

Secondly, though in the post-colonial era Livingstone is still celebrated,<sup>167</sup> he is no longer universally uncritically revered as the heroic explorer of the 'Dark Continent' as he was during his own lifetime until well into the 20<sup>th</sup> Century.<sup>168</sup> Instead, with hindsight, at least in the global South, he is likely to be understood in a more complex way. From the perspective of 21<sup>st</sup> Century post-colonial scholarship, the enterprise to which he devoted his life, namely the geographical exploration of Africa to prepare the way for colonial conquest is understood very differently. In South African scholarship, it is now more likely for Livingstone to be seen as a member of the vanguard ushering in the historical catastrophe that was colonialism (Bogues, 2010), than as a fearless and self-sacrificing hero to the cause of British imperial expansion.

As for his personal qualities, on 19 March 2014, the centenary of Livingstone's birth, his biographer Tim Jeal noted that in his 1973 biography he had outlined how Livingstone

... had made but one convert, who had lapsed; that his wife had been abandoned and that his eldest son had changed his name and gone to live in America. As a geographer, Livingstone made faulty observations and had

---

167 The 200-year celebration of Livingstone's birth in 2013 included a wreath-laying ceremony at Westminster Abbey and an academic conference held in Livingstone, Zambia, hosted by the London School of Economics.

168 According to Jeal, Livingstone's fame came about through a combination of public ignorance about Africa and press hyperbole, instigated by Stanley. Following Stanley's one sided depiction of Livingstone after their famous 1873 meeting, Livingstone came to '... [exemplify] ... the virtues that the Victorians most valued: bravery, moral rectitude, industriousness, endurance, modesty and willingness to sacrifice his life for a cause — epitomising for later imperialists the hugely reassuring ideal of selfless "service" given to the ruled by their white rulers' (Jeal, 2013).

therefore misled people into thinking whole regions suitable for trade and missions, which were in fact inaccessible and malarial. He had often been cruelly critical of men who had just died (Jeal, 2013).

Jeal noted that most of all, he had deplored Livingstone's callousness towards his wife and children, whom he neglected while pursuing his dreams as an explorer. At the same time, though, Jeal acknowledged that with the passage of time, he had come to respect Livingstone as an individual, for his tenacity, his bravery, his non-racist attitudes and anti-slavery stance, as well as for his ability to engage with Africans as equals, which was uncharacteristic of the Europeans of his time (Jeal, 2013). In the light of these more subtle understandings of Livingstone and his place in history, the chip of wood now speaks, like the Rhodes 'deathmask', of the constant revisions to which scholarly understanding of the past is subject.

### ***The artwork: Musa Askari***

A series of email enquiries to the McGregor Museum and other museums in Kimberley in 2013 proved fruitless in bringing to light any information with regards to Immelman's purchase of the chip of wood. However, this was not the dead end that it seemed to be, since my enquiry led to the unearthing of the only information in the museum relating to the tree at Kuruman, a photograph of the man responsible for chopping it down. The caption of this image reads 'Musa Askari, who cut down the Livingstone tree in 1899' (Vida Allen, email correspondence, 9 July 2013).

Musa Askari only entered the records by virtue of his twice removed association with David Livingstone — nothing whatsoever is recorded of the rest of his life. This lack of a recorded afterlife speaks of the most common fate of the colonial subaltern class, '... pushed to the social margins ... [their] ... non-Western ways of perceiving, understanding, and knowing the world denied' (Spivak 1994:76), as much in death as in life. Similarly, under colonialism and apartheid, millions of other subaltern South Africans, their lives considered irrelevant to posterity, were almost entirely excluded from the records, so that only rare, tangential traces of their histories are to be found within our archives.<sup>169</sup> Using

---

<sup>169</sup> As Hamilton describes this phenomenon, 'Here we begin to grapple with the ways in which the formal



the image of Musa in *Slantways*, I wished in some way to bring these missing stories into play.

Like the steamship, quinine and the Gatling gun, photography evolved with and was used to pursue the aims of colonialism (Landau, 2002b:142).<sup>170</sup> Thus, colonial era photographs need to be understood ‘both ... [as] ... a caption of reality as well as the products of the cultural construction of that same reality’ (Ncube 2012:3). Granted, the image of Musa was not used for the processes of ‘scientific’ human and racial classification. However, in its presentation of Musa as a typical colonial servant of the day, pictured standing stiffly and expressionlessly to attention in his servant’s uniform on completion of an act of labour, this image falls firmly within the hegemonic legitimating system of visual representation characteristic of its era (Makhubu, 2013:3).

Elizabeth Edwards and Janice Hart point out that photographs are not fixed entities. Instead, ‘... changes of ownership, physical location or material changes ... [mean that] complex patterns of values and relationships ascribed to photographs are momentarily fixed only to change again’ (Edwards and Hart, 2004:4). By reprinting the image of Musa Askari at a different scale and onto a different ground, my intention was to challenge and alter the value ascribed to it as a photograph, to enable it to speak in a different way, to stand as a kind of touchstone for the legions of lost, ignored, denigrated and/or suppressed human stories, for so long excluded from our archives.

Deep-etched, dramatically scaled up and digitally re-printed onto a 250cm x 138cm piece of 100 percent cotton voile, the image was hung high up about 1m in front of the east wall of the gallery. Without the original mundane brick wall background, it was easier to focus on Musa himself; paradoxically at the same time he became both more individual man and generic human. On this ground, as opposed to in the harshly contrasted original photograph, the image was pale and otherworldly. Also, since cotton voile is a very delicate, almost transparent fabric, and the cloth was not weighted on its lower hem, the image wavered a little with the slightest gust of air, and seemed to float in

---

archives facilitate a certain universe of meaning and foreclose on others’ (Hamilton, 2013:4).

170 Landau cautions that this was not necessarily a simple or one-dimensional process: ‘... the way Africans were pictured and the selection of which pictures circulated — and where — were the results of many individual decisions, and they cannot be reduced to a formula. Moreover, while pictures appear very specific in their denotation, they are vulnerable — even more than texts — to widely varying interpretations’ (Landau, 2002b:142).

a rather ethereal way. However, it was also big enough to be visible throughout the gallery space,<sup>171</sup> so that it loomed over the rest of the work with a quiet presence. Its placement also allowed for the development of a particularly interesting visual relationship between this work and one of the faux gold-bearing cabinets of *Hoard*, over which, from a certain angle, Musa Askari's bare feet seemed lightly to hover.

## Sense of Place I and II

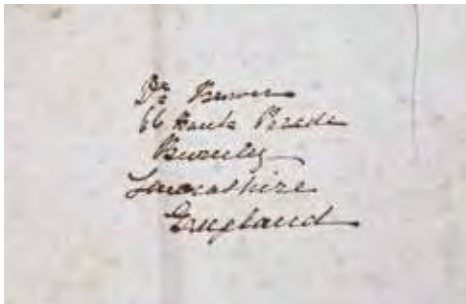

### Archival thing: The addressed piece of calico cloth

#### ***A rectangle of cloth***

The manila archival folder marked 'BC 16 Olive Schreiner Collection-miscellaneous items' contains a motley assortment of material. There are two newspaper clippings, one of them (about Schreiner's funeral in 1920 in the mountains above Craddock) neatly cut out and pasted onto a sheet of thin card; several empty, torn envelopes addressed in an old fashioned hand; a small, unprepossessing oil painting of a house<sup>172</sup> and a printed sheet of information about Schreiner from some long past display (Olive Schreiner Collection).

This seems truly to be the flotsam and jetsam of the Olive Schreiner collection; and initially, the final item in the folder seems to fit perfectly with this impression. It is a large rectangle of slightly mottled, off-white calico cloth, folded up like a map, so that when opened, its surface remains deeply creased by fold marks. The following address, written in a small, slightly untidy, cursive

---

171 It was also possible to view the image from behind the work, as the fabric it was printed on was fairly transparent.

172 This is referred to as 'painting of a Grahamstown house (Rebecca S)' in the catalogue made for the Olive Schreiner Display in the library in 1955

script in black ink that blotched on one or two letters, appears near the top of the cloth:

Dr Brown  
66 Bank Parade  
Burnley  
Lancashire  
England

Visually the cloth is uninspiring. It is only the information provided by a pencil note scribbled on a scrap of paper folded into the cloth that gives any clue as to where its value might once have lain. The note explains that ‘This bit of cotton is the outside covering of the packet (MS) “Story of African Farm” (sic) sent us by O. S. when it first came to England “to find a publisher”’ (Olive Schreiner Collection).

The catalogue records that the cloth was donated to the Manuscripts and Archives Department in 1960 by Miss N. Dick, in memory of her mother, Mrs R.E. Dick. Mrs Dick was the daughter of Mary Brown. Either Brown or Mrs Dick must have written the explanatory note.

Evidently, the addressed cloth is not the only thing (as opposed to textual material) relating to Schreiner that was passed on by Brown to her daughter, and subsequently donated to the Manuscripts and Archives Department. It also houses a bracelet made up of eleven round moonstone beads on a coarse piece of string. According to the Museum Objects finding aid,<sup>173</sup> this is thought to have belonged to Schreiner, as is a gold and amethyst brooch, which she is said to have worn in her later years. This points to a divergence between Brown’s sense of the value of things and the approach taken within the archive, even to some degree in Immelman’s day, but certainly very markedly in the 45 years since his retirement. In the BC 16 collection, as is usual in the department, text-based material is privileged, so that the numerous letters and other personal papers, such as the proof copy of Schreiner’s ‘The Sunlight Lay Across my Bed’, also donated by Dick, are considered to be more valuable than the cloth, the bracelet, and the brooch, which seem to have been understood as curiosities

---

173 It is noted that ‘Miss Eberhard thinks that these belonged to Olive Schreiner. Were they perhaps given by U Scott?’

and largely ignored (Olive Schreiner Collection).

Admittedly, the cloth was publicly displayed for several months in 2004, as part of Skotnes, Langerman and van Embden's exhibition *Curiosity CLXXV*, which coincided with UCT's 175th anniversary, and is on record in the publication that accompanied the exhibition. After this moment, though, it was restored to the obscurity of the BC 16 'miscellaneous' folder.

### ***A long friendship***

Schreiner first met Mary Brown in 1873, when, after a stint on the diamond mines in Kimberley with her brothers Theo and Will, she visited her sister Alice Hemming, who lived with her family in Fraserburg in the Karoo. At this time, Schreiner was only 18, while Mary Brown, whose husband John had been appointed as District Surgeon in Fraserburg in 1865, was 26 (First and Scott, 1980:69).

Mary Brown evidently felt an immediate and lasting affinity with Schreiner — she records in her memoir that the first time they met 'She made a great impression on me ... she seemed to hold me with a sort of subtle power' (Brown, 1955:2).

Brown's interest was reciprocated by Schreiner, who also developed a strong bond with Brown's husband, John.<sup>174</sup> The affection between Schreiner and the Browns persisted for 47 years until Schreiner's death in 1920. This bond inspired Brown to write her memoir of the 'affection which has been one of the greatest possessions of my life', in which she emphasises '... the depth of ... [Schreiner's] ... compassion, her spirit of forgiveness and her comprehensive sympathy with all suffering' (Brown, 1955:1).

### ***The parcel***

In late 1879 or early 1880, when the Browns had been living in Burnley, Lancashire for three years, Schreiner sent them a parcel containing the first

---

174 According to First and Scott, 'Olive was very taken with them: they were like "two stars that shone in my sky when all the rest was dark." Preoccupied with her own depression, even with thoughts of suicide, she was reassured by the strength of feeling the Browns had for one another: Olive found it "so wonderful" that Mary should cry such "bitter tears" at the prospect of a brief separation from the man to whom she had already been married for five years' (First and Scott, 1980:69).

draft of her novel, *The Story of an African Farm*, in the hope that they could find her a suitable publisher.

Brown knew well how hard Schreiner had worked while writing the book. Over the previous four years, she had received letters from Schreiner describing her intense loneliness and the difficulties she had experienced as governess in a succession of isolated farms in the Karoo, as well as the halting progress her duties allowed her to make with the novel she had begun writing in 1874. Brown recalls that, 'She said she could only write her story at night, and when I saw that careless and untidy manuscript, I remembered under what difficulties it had been written' (Brown, 1955:3).

However, in her own estimation, Brown's reaction to the arrival of the parcel and her subsequent careful custodianship of the addressed cloth that it was wrapped in related to more than her sense of empathy for the travails of a beloved friend struggling to express her talent in difficult circumstances. Also, though she immediately recognised the book's literary value, recalling that the 'delight and satisfaction I cannot describe' she felt on reading the manuscript was so strong that she was unable to express it properly (James and Hills, 1937:33), her response was not primarily based on the parcel's contents.

Instead, Brown's most immediate, most powerful response was to the cloth the manuscript was wrapped in, and the way it related to her own life experience.<sup>175</sup>

### ***Souvenir of the Karoo***

For Brown, as she opened the parcel, the addressed cloth instantly took on the qualities of a souvenir, with the potential to transport her imaginatively both into her own past and into the distance of a faraway place. The simple explanation for this very pronounced reaction is that Brown was homesick and longed for the Karoo.

She begins the passage recalling the arrival of the parcel by explaining that,

I had been away from South Africa for three years, and no Scotsman ever longed for his heather hills and no Swiss for his mountains more than I did for my native

---

175 Possibly, as time passed, this feeling may have grown more complex, so that in later years, the cloth might for Brown have stood in metonymic relation to the manuscript it had once contained, as well as more indirectly to the friendship and trust between the parcel's sender and its custodian.

land, or even for the sun-baked Karroo (Brown, 1955:3).

Into this charged affective space comes a parcel from the very heart of Brown's longed-for, lost landscape, a parcel that brings with it an unmistakable remembered smell. Brown's response was instantaneous and visceral:

When I opened ... [the parcel] ... in those wintry surroundings — with the noise and stir of a manufacturing town about me — a flood of emotion came over me, for I was met with the strange, pungent smell of the smoke of wood fires, familiar to those who know a Karroo farm. I folded that bit of cotton cloth almost reverently, and I have it still (Brown 1955:3).

Brown initially refers to the smoky smell of the cloth in terms of its evocation of memories of farm life. However, since such farms existed within the very particular Karroo landscape, the smell of the cloth called up a vision of that landscape itself. The potency of this vision is accentuated by its absolute contrast with the unremitting midwinter grimness of the alien English industrial setting Brown has been transplanted into. The atmosphere of its reception is thus in the starkest possible contrast to the intense heat of the midsummer she knew it had been sent from, and must have been able to imagine with great vividness.

For Brown, the cloth seems to have fulfilled what Stewart understands as the double function of the souvenir: it '... authenticate[d] a past or otherwise remote experience and, at the same time ... discredit[ed] the present' (Stewart, 1993:139). As 'an object arising out of the necessarily insatiable demands of nostalgia' (Stewart, 1993:135), for Brown the cloth '... [spoke] ... to a context of origin through a language of longing' (Stewart, 1993:135).

### ***A deep attachment***

The Karroo landscape, so central to the manuscript once wrapped within the addressed cloth, was also of immense importance to Schreiner herself. According to John Coetzee, *The Story of an African Farm*, as opposed to the work of Pauline Smith and many later South African writers, does not belong to the genre of South African pastoral writing, which '... looks back, usually in a spirit of nostalgia, to the calm and stability of the farm, a still point mediate between the wilderness of lawless nature and the wilderness of the new cities'

(Coetzee, 1988:4). Instead, he understands the novel as antipastoral, with Schreiner subscribing to

... a rival dream topography ... of South Africa as a vast, empty, silent space, older than man, older than the dinosaurs whose bones lie bedded in its rocks, and destined to be vast, empty, and unchanged long after man has passed from its face ... To Schreiner ... Africa is a land of rock and stone, not of soil and water (Coetzee, 1988:7).

In this conception, Coetzee's concern is to present Schreiner as the first in a line of white South African writers struggling to find the appropriate language to express their own relationship with terrain that they experienced as ancient and hostile. As such, his analysis does not address the realm of feelings — the deep sense of belonging to this landscape Schreiner often described both in her writing as well as in her personal letters.<sup>176</sup> These feelings are succinctly summed up in *Thoughts on South Africa*, in which she remarks, 'To the stranger, oppressive, weird, fantastic, it is to the man who has lived with it a scene for the loss of which no other on earth compensates' (Schreiner, 1992:35).

Brown must, of course, have been aware that a deep attachment to the Karoo landscape was at the heart of much of Schreiner's writing. *The Story of an African Farm*, from its first lines, evokes this landscape, and this shared feeling perhaps adds another layer to the longing that the smell of the cloth activates.

The fact that for Brown, the addressed cloth evoked the longed-for qualities of the Karoo via the smell that permeated it, is not particularly surprising, since the psychological link between smell and affect is the stuff of both everyday human experience and literature. This phenomenon has been recognised by scholars for some time. As Douglas Porteous puts it, '... smells environ. They penetrate the body and permeate the immediate environment, and thus one's response is ... likely to involve strong affect'<sup>177</sup> (2006:91).

Likewise, the fact that the smell evoked such a strong memory is not remarkable, as the association between smell and memory, introduced by Proust in *Swann's Way* in 1913, and now actually known to psychologists

---

176 See Olive Schreiner Letters online (2012).

177 Though in this article Porteous contrasts the sense of smell to vision, claiming that '... visual experience is much more likely to involve thought and cognition' than smell is, later research contradicts this view (2006:91).

as the 'Proustian hypothesis of odour memory' is well established. The simple neurological explanation for this phenomenon is that smell receptors are directly linked to the limbic system, the seat of emotion, hormones, temperature and the nervous system in the brain (Porteous, 2006:101). The evocative power of smell can be further understood in terms of its symbolic capacity: smells 'bypass all forms of coded communication and set up direct links between nature observed and the inward state of the observer' (Sperber, 1975 in Drobnick, 1998).

To these understandings can be added more recent research into synaesthesia, which suggest that there is far more interconnectedness between the parts of the brain associated with particular senses than was previously understood (Howes, 2006:386).

It might thus be speculated that though Brown's emotional response was stimulated by a smell, the memories evoked would very likely have been linked to a broader sense of the Karoo, that included sound-related and visual memories.

The sense of smell does not much feature in the Manuscripts and Archives Department. At most, researchers might be aware of the slightly musty smell of old papers,<sup>178</sup> or conceivably the whiff of fixative on photographs printed in the now distant era of chemical processing. Generally speaking, smell is not conceived of as an aspect of the actual business of the archive either: although Jim Drobnick (2005:268) discusses the recent phenomenon of what he understands as the increased public sensitivity to the issue of smell (or its absence) in museums, there seems to be no comparable interest within the archive, where smell is never understood or described as a noteworthy aspect of the conserved materials or seen as a potential avenue of research. At least within the Manuscripts and Archives Department, it is unique for the smell of an artefact to be named as the principal quality associated with it, the quality that explains its value to the donor.

It is precisely this issue that results in a certain sad irony to the cloth's presence in the archive. It is impossible to know how long the smell of wood smoke permeated the addressed cloth in the time following the parcel's arrival in the Brown household. Might a trace of it have lingered when it was donated in 1960? This seems unlikely; and if it did, it was not considered remarkable by

---

178 See Steedman (2001) for a discussion of the spread of anthrax from the inhalation of dust in archives.

the librarians of the day, and remained unrecorded. Nowadays, the smell is no longer even remotely present, so that without Brown's memoir this vital dimension of the cloth's biography would be altogether lost.

***The artwork: Sense of Place I: the scent of longing***

Brown's description of her passionate reaction to the smell of the addressed cloth, and her subsequent nostalgic attachment to it was a perfect starting

point for this work, in which I wished to challenge the lack of interest in the epistemological value of smell I experienced within the archive, by adopting a smell-based approach as a new angle of access.

Though I could not guarantee what, if any, affective response it might evoke in the audience, my concern in *Sense of Place I* was to re-evolve the power that Brown experienced as emanating from the addressed cloth by presenting my own fabric impregnated with the scent of wood smoke in the exhibition space. Accordingly, I smoked two curtains over a fire built from *soetdoring* or *acacia karoo* branches and twigs, an indigenous tree that is extremely common throughout the Karoo. These curtains were then hung one behind the other on rails in the narrow passageway leading to a small room adjoining the main exhibition space, in which the video was shown, so that visitors were forced to engage intimately with the smell. This engagement included brushing against the cloth as the viewer's body passed through the curtains, so that traces of the smell might linger on their clothes and hands





while they watched the video.

***The artwork: Sense of Place II: Karoo April 2014***

To watch this work, go to <https://www.youtube.com/watch?v=jb2p4utwIjk>.

This is a wild beautiful place. The farm house is perched high up, on the side of one of the mountains & the bush which comes down to the very garden is as unman defiled as one could wish & wild as one can wish. I have only to teach for five or six hours a day & all the rest of my time I can spend out of doors, or in my own little room studying [Description of Klein Ganna Hoek from a letter from Olive Schreiner to Margaret McNaughton, September 24 1878] (The Olive Schreiner Letters Online, 2012).

I filmed this three-minute six-second video over two consecutive days in April 2014, while visiting the farms Ganna Hoek<sup>179</sup> and Rietvlei (previously known as 'Leliekloof') in the Craddock district.

Though the timeframes for the writing of *The Story of an African Farm* are not entirely certain,<sup>180</sup> it is thought that Schreiner began writing at Klein Ganna Hoek when she lived there from 1875–1876.<sup>181</sup> Although a good part

---

179 Klein Ganna Hoek was previously a separate farm, but is now a remote part of the farm Ganna Hoek, still owned by the Cawood family.

180 Schreiner worked on her first three books at the same time over the seven year period she worked as a governess, from 1874–1881 (First & Scott, 1990:70-71).

181 Schoeman points out that 'from this period derives the classical image of the young governess in her little



of the novel was subsequently written at the farm Ratelhoek, she later wrote more while staying with her friends the Cawoods at Ganna Hoek from March to June 1879, and made her final revisions at Leliekloof just before the book's first publication under the pseudonym 'Ralph Iron' in 1883.

This video work was intended to complement *Sense of Place I*, so that after passing through the curtains that smelled like wood smoke, the visitor would continue on his or her sensory journey, this time via the senses of hearing and (sometimes simulated impaired) sight — another effort to challenge the given order of the archive by accessing it in a different way.

In the first scene, inspired by my imagining of Schreiner making the arduous trek between Cradock and Leliekloof on foot, or almost equally slowly, by ox wagon, the video begins with my own slow trudging along the dirt road that she must have taken, about 140 years ago. As the camera is hand held, the image is slightly shaky and swings from side to side with each step. In the next scene, the camera lingers on the signpost to Rietvlei, below which 'Leliekloof', the name used in Schreiner's time, is still visible. In the third scene, the camera pans slowly over the ruins of the house where Schreiner worked at Klein Ganna Hoek — two or three shallow steps marking the entrance to the house, a few remaining bricks that indicate the placement of its perimeter walls, and

---

clay-floored room on cold, clear winter nights, sitting before the window with its view of the ravine and cliffs and reading or writing in moonlight for lack of candle ...' (1991:346).

the occasional shard of pottery or rusty metal. Finally, the camera stops and focuses on a thorn tree faintly visible against a backdrop of mist and cloud. In this scene, as well as in the one showing the sign to Rietvlei/Leliekloof, I used a makeshift plastic filter to blur the image, as a means of communicating my own very particular visual experience of these two sites. To create a contrast and hopefully alert the viewer to this intention, these scenes are alternated with the same scenes shot through an unfiltered lens, allowing for clear and easy vision. This alternative viewing experience was intended to underline the possibilities presented by this work to speak metaphorically of a different approach or line of vision than the one employed as a matter of course. To enhance this objective, I also made various other efforts to challenge viewers and disrupt their ease of viewing. Firstly, while shooting, the camera was held vertically rather than horizontally, so as to produce an atypically long and narrow image. The angular effect created by this strategy was further enhanced in the exhibition, where the elongated image was projected into a corner of the small viewing room, to give it a sense of being at a peculiar, slanted incline — a strategy that slightly discomforts and disorients the viewer, so that he/she is forced into watching the video from a different perspective, and also to be aware that this is the case while that watching is taking place.

As a creative response to Brown's expressed longing for the Karoo, Schreiner's love of this landscape, as well as to create some sense of my own subjective experience of these sites as places inspiring meditation on the passage of time and the inevitability of decay, I hoped to evoke the feeling of quiet melancholy that pervaded the ruins I filmed for this short video.

This desire in no way clashes with or contradicts my primary sensorially-based approach to the making of the video, since sensory perception and what the senses are understood to be are far more fluid than is often imagined. Understandings of the senses vary widely both within and across cultural groups (Vinge, 1975:107 cited in Howes, 2011:435).<sup>182</sup> In many non-Western cultures, the familiar hierarchy of categories outlined by Aristotle — sight, hearing, smell, taste and touch — are overturned, and other attributes of embodiment, including sentiment are included (Ricke, n.d.).<sup>183</sup>

---

182 See Classen (1998), Howes (2005) and Howes (2011).

183 For example, Howes (2011:436) refers to the Javanese, amongst whom the five senses

Partly because the video was shot on an overcast day, and partly because of the quiet and loneliness of the ruins at Klein Ganna Hoek, a pervasive sense of melancholy does, to a certain degree, come across visually, but I tried to heighten this via the sound track. The video opens with the faint sounds of early morning bird song, which soon merges into my own footsteps crunching along the gravel road leading to Leliehoek. After about one minute, the tick-tock of an antique clock is introduced, culminating in its melodic chiming of the hour of nine o' clock — roughly the time at which my own visit to the site began. Together with the blurry images created by the filter as outlined above, it served as a reminder that the video was the record of my own very particular contemporary experience, in a sense overlaying the story of the past presented by the scenes I visited, but hopefully not obliterating it.

## Translation I: The Queen's Speech



### Archival things: the pen and the record

#### *The Royal touch and the Royal voice*

In 1947, on the brink of the fateful election that saw the coming to power of D.F. Malan and the imposition of the apartheid system, the British Royal family spent just over two months touring the Union of South Africa. On 22 April 1947, two days before the end of the tour and the Royal departure, UCT conferred an honorary Doctorate of Laws on the then Queen Elizabeth.

Under the three-tiered headline 'University gives Queen an ovation/  
Degree conferred on Her Majesty/ MOVING CEREMONY IN JAMESON HALL', The

---

are understood to be seeing, hearing, talking, smelling and feeling (Dundes cited in Howes 2009:2), and in Buddhism, 'mind' or thinking is included alongside the five senses listed above.

Argus describes the event as:

... a simple, dignified and deeply moving ceremony ... in which Her Majesty occupied the centre of the stage as the Chancellor of the University, General Smuts, conferred the degree upon her (The Argus, 22 April 1947).

The report noted that,

Long before the doors of the Jameson Hall were opened, professors, lecturers and students thronged the steps leading to the Hall. The brilliant gowns of the professors, mingled with the black undergraduate gowns of the students, formed a spectacle, which must have been one of the most colourful of the whole royal tour (The Argus, 22 April 1947).

As well as paper-based ephemera — specially printed parking stickers, the programme for the event, several copies both of the Queen's acceptance speech written up in calligraphic script and of her signature — the archive contains two artefacts associated with this occasion.

The first is a pen, donated by R.F.M. Immelman. It is described in the Museum Objects finding aid as: 'Black fountain pen with gold top used by H.M. Queen Elizabeth to sign the visitors' book in the Librarian's Office, Jagger Library in 1947.' Though there is no text available that says as much, it seems extremely likely that, as with the chip of wood associated with David Livingstone, the value assigned by Immelman to this artefact and his motivation for donating it was the issue of celebrity. By virtue of it being held by the Queen to sign the visitors' book in the library, this particular pen gained an unassailably unique aura. The fact that the pen was used to testify to the Queen's visit to the library to which Immelman was so wholeheartedly committed, and that he himself was present on this occasion, can only have added to his sense of its powerful magic — he had witnessed its witnessing of what he must surely have considered to be a glorious event.

The second artefact is a gramophone record, listed in the Museum Objects finding aid as 'H.M. Queen Elizabeth accepting Hon Degree from UCT 1947. New York: Record Disc Corporation [1947]. Speed 78rpm. In navy folder'.<sup>184</sup> This record was the starting point for *Translation I: The Queen's Speech*, the first of

---

<sup>184</sup> I produced versions of both of these artefacts for *Hoard* before producing this artwork.

the three artworks that set out to use the senses other than seeing — in this case, the sense of hearing — as a means to approach the archive from a variety of different sensory angles.

### ***Archival hearing loss***

As Leigh Eric Schmidt points out,

... the sovereign nobility of vision, ostensibly redoubled by the Enlightenment, has made the modern story almost always one of profound hearing loss in which an objectifying ocularcentrism triumphs over the conversational intimacies of orality (Schmidt, 2002:7).

Furthermore, despite the efforts of theorists to historicize and deconstruct essentialist conceptions of visuality since the late 1970s, in the cultures of the West the sense of sight continues to dominate, not only as far as its relationship with hearing is concerned, but also with regard to the senses of smell, taste and touch (Drobnick, 1998). Drobnick suggests that critiques of visuality either seek a return to some kind of ‘innocent’ gaze, or attempt to link the non-visual senses to the visual. In both cases, the visual continues to be the privileged sense, and ‘the political and aesthetic significance of alternate modes of sensorial engagement ... remain largely unacknowledged’ (Drobnick, 1998). Furthermore, as Veit Erlman points out, until very recently there has been a conspicuous absence of research into the place of sound and hearing in the cultures of the global South (Erlman, 2004:4).<sup>185</sup>

It seems to me decidedly ironic that, though the record is emblematic of sound in the archive, and should thus, of all the artefacts I worked with, most unproblematically tell its story, nobody ever listens to it — and nor, seemingly, is there any more contemporary version of this recording in the archive that researchers could access more easily.<sup>186</sup> My research revealed that there are also many other recordings attached to particular collections

---

185 Recently, this has been to some extent rectified with the publication of *Social Dynamics*, Volume 41 Issue 1 (2015), which is devoted to this topic. The essays in this issue grew out a series of workshops relating to sound, and practices of listening and sonic knowledge production held by the APC from 2012 to 2014. (UCT 2015d)

186 Reference was made to a recording presented to Prince Charles by the UCT Public Relations Department, but this never materialised (Clive Kirkwood, email correspondence, 3 March 2013). I subsequently phoned the public Relations Department, but there was no record of the recording.

in the custodianship of the Department, ranging in content from collections of interviews, through the personal reminiscences of particular individuals to recorded speeches made by political leaders of the colonial era. In 2013, the then manager of the Manuscripts and Archives Department, Lesley Hart, estimated that the archive contains 21 gramophone records, 225 reel-to-reel recordings, 1236 audio cassettes and 157 recordings of an indefinite format, only known to exist via the finding aids. Then there are the wax cylinder recordings that form a part of the Bleek and Lloyd collection, as well as the ‘sonic absence’ or ‘deaf spot’ represented by the irretrievably damaged but still conserved wax cylinder recordings that form part of the Kirby collection (Zimmer, 2015). Furthermore, other recordings not yet listed are in existence, attached to different collections and till now forgotten or ignored (Debra Pryor, email correspondence, 3 February 2015).

Though this list seems to represent a modest but still noteworthy assortment of audio material, evidently none of it has been considered as worth featuring as a research focus within the archive.<sup>187</sup> It is only now, in 2015, that a digitisation project is underway to make listening one possible way of accessing the archival material.

This indicates that the ‘profound hearing loss’ referred to by Schmidt has until now definitely prevailed within the Manuscripts and Archives Department, so that *Translation I* for me felt as if it included a restorative gesture in the direction of listening.<sup>188</sup>

### ***The artwork: Translation I: The Queen’s speech***

To listen to this work, go to <https://soundcloud.com/joanne-bloch-26408010/translation-i-the-queens-speech-final>.

The artwork consists of a six-minute 16-second version of the Queen’s speech, translated into and performed in SiSwati by Manesi Kekana. The speech was played through speakers placed on a high antique plant stand in front of

---

187 These recordings include life story interviews, recorded musical performances and political speeches and debates (Debra Pryor, email correspondence, 3 February 2015).

188 There is another artefact relating to sound, this one innately mute and only bearing the trace of a sound that can never be listened to, in the Manuscripts and Archives object collection. In the Museum Objects finding aid, this thing is listed as the ‘echo sounding chart of the maiden voyage of Swedish trans-Atlantic line vessel Kanangoora passing over Aliwal Shoal near Umkomaas mid 1939’



a section of dry wall on the southern side of the gallery. It was played softly, so that visitors would be encouraged to come close enough to the speakers to engage with it fully. As it was played every 15 minutes, it had an insistent, interrupting presence in the gallery space, returning visitors repeatedly to the imagined history it presented.

As well as focusing on and celebrating sound as a means to access the archive from a different angle, as the name indicates, *Translation I: The Queen's speech* is also the first of three artworks presented on *Slantways* incorporating acts of translation. In this case, the result of the translation was that the performed speech became the speech of an African monarch from a neighbouring state accepting an honorary PhD, rather than that of an imperial queen also accepting her PhD but at the same time addressing her subjects in a remote corner of the empire.

According to Benjamin, though the original cannot enter 'the realm of reconciliation and fulfilment of languages', the part of the translation that 'goes beyond the transmittal of subject matter' or 'that element in the translation that does not lend itself to a further translation' can (Benjamin, 1996:257-258).

The effect of this is that '... translation does not serve the original, but liberates and releases its potential — which resides in that which resists translation ...' (Bal & Morra, 2007:5). This conception allows for translation to

be considered as ‘... a poetic, hermeneutic, political and experiential mode’ (Bal & Morra, 2007:9). This is the spirit in which my re-working of the royal visit to UCT takes place, allowing for the fantasy of an altogether different history both broadly, i.e. in the sense of national history, and on the level of the institution itself. This, in turn, permits the contemplation of two interlinked questions: how might we, as South Africans feel now had our history been different? And, currently even more relevant, how might the different history suggested by this artwork have made the UCT students of today feel about this institution?

As mentioned above, this record remains silent in the archive; and though I asked several times to be facilitated to listen to it, it was evidently difficult to procure a record player or access a digital version of it. This meant that ironically, for the course of my research, the original speech was located, metaphorically speaking, in the domain of the gold pen rather than that of the record. In other words, I could only access it by reading its transcribed version.

Despite my faith in the materiality of things as a starting point for my creative work, initially the reduction of the record to a thing bereft of sound disconcerted and frustrated me. As Annette Hoffman and Phindezwa Mnyaka point out, ‘Even the recorded voice vociferates — and thus always generates an excess of meaning that cannot be reduced to that which can be transcribed’ (Hoffmann and Mnyaka, 2014:141-142).

Ultimately though, the record’s muteness proved to be inconsequential to the impact of the final artwork. Thanks to the skilled input of sound artist James Webb as well as Kekana’s sensitive performative, this excess was effectively re-created. In the translated and performed version of the speech, an intended distortion of the sound and a faux crackle activated a sense of the sound qualities of an old record, as opposed to those of later technology. The sense of a (different, but still) regal presence at ‘the centre of the stage’ also came to life in Kekana’s rendition of the speech, despite the fact that she too had not heard the original.

Obviously, only those visitors who spoke siSwati could actually understand the translated and performed speech.<sup>189</sup> This meant that, to enter the creative space the work invited them into, most visitors were forced to listen very

---

189 There could not have been many such visitors, considering that *Slantways* took place in Cape Town, far from Mpumalanga where most South African siSwati speakers live.

carefully not to the meaning of the words, but rather to less tangible aspects of the recording that fall outside of conventional discourse — the ambient noise, the emotion conveyed by Kekana’s emphases, the timbre of her voice, the crackle mentioned above, and so on. This highlights the potential of sound art to engage less rational ways of knowing, but also raises the possibly unanswerable question of the degree to which the veracity or otherwise of the translation actually matters.

As Bal and Morra explain, as well as

... work[ing] within discourses and practices of intertextuality, intersemiotics and inter-disciplinarity ... translating across [media] is concerned with the marginal, the gaps, fissures and contradictions of working in the interstices between ... various boundaries (Bal & Morra, 2007:7).

Seen in this light, it was not inappropriate for the performed artwork to be situated in a space without any reference to the original aural source, which for most listeners could only be accessed affectively and sensorially. These gaps aside, the act of translation undertaken was in a very real sense concerned with another gap — in this case, the gap (in fact massive chasm) between what actually took place and what might have taken place, but did not.



## Translation II: From ‘The New Game of HUMAN LIFE’

Archival thing: the puzzle piece – ‘The Troublesome Companion’

### *The puzzle in the archive*

‘The New Game of HUMAN LIFE’ is a round wooden puzzle donated to the

archive in 1957 as part of BC531, the Jeffcoat collection.<sup>190</sup> The puzzle is described in the Museum Objects finding aid as ‘London: J Wallis<sup>191</sup>, 1790. Wooden jigsaw complete in wooden box with sliding lid. 20 x 24 x 7cm’. Inside the box, a typed slip of paper explains that ‘[t]his puzzle was in the possession of the Jeffcoat family from 1790 until recently. This family was related to the Hiddingh and Hertzog families at the Cape (presented by Rev R Jeffcoat)’. This explanatory note possibly dates back to one of the exhibitions held in the library in Immelman’s era.

Each puzzle piece depicts a printed coloured image of one of about 80 male characters, complete with an explanatory title. The pieces include, amongst many others, ‘The Satirist’, ‘The Obstinate Youth’, ‘The Old Man’, ‘The Silent Man’, ‘The Rebellious Youth’, ‘The Darling’, ‘The Generous Man’, ‘The Immortal Man’, ‘The Brute’, ‘The Romance Writer’, ‘The Author’, ‘The Hypochondriac’ and ‘The Ambitious Man’.<sup>192</sup>

The Division of Rare and Manuscript Collections at Cornell University also boasts one of these puzzles. According to their website, the puzzle pieces were intended as moral archetypes of their day:

The New Game of Human Life encouraged young players to develop proper moral character, learning the exigencies of the seven stages of life, from “Infancy” to “Dotage,” while navigating the paths of vice and virtue. Players advance or forfeit according to the moral nature of the character represented in the square they land on. “The Assiduous Youth” or “Benevolent Man,” for instance, allowed players to advance, while the “Drunkard” or “Negligent Boy” forced players to lose a turn or to move backward. The game illustrates late-eighteenth century social values assigned to various careers. Landing on “The

---

190 This collection, which entered the archive between 1950 and 1972, contains other Victorian games as well as numerous 19<sup>th</sup>-century etchings, watercolours, engravings and letters.

191 According to the website of the New York-based George Glazer Gallery, ‘John Wallis (d. 1818) was a London game, book, map and print maker and seller, operating from 1775, when his business was called the Map Warehouse. In 1805, he opened the Instructive Toy Warehouse. He published music imprints, maps by John Cary, and children’s material, co-operating with the Newberys and various provincial retailers. With his son Edward, who joined the business in 1813, he also operated Wallis’s, a circulating library and reading room. Together they published under the imprint Wallis and Son or John & Edward Wallis. Edward succeeded his father and published under his own name until about 1847, at which time the Wallis stock was taken over by J. Passmore’ (George Glazer Gallery, n.d.).

192 The absence of female characters speaks of course, of the gender dynamics prevailing at the time at which this puzzle was produced. Had I had more time available, the characters portrayed in the puzzle might have inspired more parodic cross dressing performances, similar to those I undertook for *Troublesome Ancestors I and II*, and *Homage to Mr Immelman*.



Romance Writer,” for instance, sends the player back to “The Mischievous Boy.” Similarly, the “Dramatist” forces the player to begin the game again (Cornell University Division of Rare & Manuscript Collections, 2004).

### ***A list of characters***

Partly because the rules of the game are printed as part of the puzzle itself, in tiny, ornate cursive script that I failed to see before I was alerted to its presence, at the time of my initial research, I was not conscious of this imposed moral framework. This gap in my understanding, which might well be seen as a weakness in my initial research process, was actually an advantage — it allowed me to relish the array of characters represented in the puzzle as a peculiar list speaking to me across 200 odd years of its time and place, ‘swing[ing] ... between a poetics of “everything included” and a poetics of the “etcetera”’ (Eco, 2009, introduction).

For the artwork that I made in response to this puzzle, I chose to work with my favourite of all the puzzle pieces, ‘The Troublesome Companion’, which depicts an angry-looking man, belligerently waving both fists in the air. This



seemed an appropriate metaphor for my desire, with the help of stories the things' shared with me, to unsettle the apparent certainties of the archive.

***The artwork: Translation II: From 'The New Game of HUMAN LIFE'***

*Translation II* incorporates a double act of translation. Firstly, there is the simple word-for-word translation of the phrase 'The Troublesome Companion' into Braille. Secondly, there is the cross-medial translation of a small puzzle piece into a 4 m long artwork. Both the original artefact and the resultant artwork are tactile and visual, though in very different ways; and both of them were designed with (very different) ethical questions in mind, speaking to the values of two eras and two places separated by roughly 200 years and 6 000 miles.

The artwork was presented at eye level on the northern wall of the gallery. Each of the 67 raised dots making up the phrase 'The Troublesome Companion' in Braille was represented by a handmade woollen pompom, approximately 5 cm in diameter.<sup>193</sup> These mocha-coloured pompoms were displayed on a strip painted the same colour that ran the length of the wall, to mimic the effect of Braille printed onto embossed paper, although obviously on a far larger scale than it is usually encountered. The wall text for the work encouraged viewers to touch it, and many took the opportunity to do so. Even if the work remained untouched, the fuzzy yet compact texture of the pompoms, visible from even a few metres away, strongly recalls the sensory experience of touch.

***Issues of access***

No South African artwork using Braille can hope to escape comparison with

---

193 The use of pompoms in this work represented a new stage in an approach I have adopted in many previous artworks. *The beautiful adventure*, exhibited at Goodman Cape Town in 2008 was closest in spirit and dimensions to this work. It consisted of an approximately 4m x 2m grid of multi-coloured pompoms arranged on both sides of the large black ground provided by a dry wall.



Willem Boshoff's iconic work, *Blind Alphabet* (1990–), in which

...a blind language of arcane and recondite words which render the sighted functionally illiterate is transposed and re-introduced, by means of sculpted wooden forms and Braille texts, meditated by the empowerment of the non-sighted (23rd Sao Paulo Biennial, 1996:14 in *Willem Boshoff-Nonplussed* catalogue, 2004).

Boshoff, who had compiled a dictionary of archaic English words, explains that:

I decided to make an art installation that would enable blind people to function as gifted experts instructing disenfranchised sighted people ... To put sighted people at a disadvantage I needed to impose upon them a sense of the disappointment blind people suffer when they are restricted. The way I “blind” sighted visitors to the artwork is to hide the sculptures in small boxes, under



wire mesh. The art gallery's signs reading "Don't Touch" prevent them from opening the boxes, so that they are overcome by frustration. Furthermore, the lid on every box is inscribed with a text in Braille, which is foreign to most sighted people. Then, to cap everything, there are hundreds of these sculptures in row upon row, in close proximity. The sighted visitor feels denied, lost in a labyrinth that might lead nowhere (Willem Boshoff Artist, 2012).

Likewise, an important aspect of my own Braille work, *Translation II*, was to draw attention to the issue of access and its lack. Most importantly, in keeping with the broader aims of the project, the work speaks of my desire to access the things within the archive from a curious and unexpected angle, incorporating a multi-sensorial perspective not often used in that context. In this regard, *Translation II* complements both the sound piece, *Translation I: The Queen's Speech* and the smell piece, *Sense of Place I*.

More generally, this Braille work again makes use of the '... poetic, hermeneutic, political and experiential mode' (Bal & Morra, 2007:9), here offered by the act of translation to reference the form of limited access addressed by Boshoff, namely disabled access to art and cultural artefacts within galleries, museums and institutional collections.

While (despite the potency of *Blind Alphabet*, which has been widely exhibited) in the South African context, such access occurs at best sporadically and in a very limited way, many large institutions globally do make an effort to provide access to people living with different disabilities.<sup>194</sup> In terms of addressing discriminatory practices within a human rights framework, such programmes are clearly important. However, in its narrowness, this focus is in danger of perpetuating both the segregation of disabled individuals and of stereotypes of disability. In the interests of proposing a more far-reaching understanding of what 'access' implies, Amanda Cachia proposes that a strong emphasis on utilising the discursive turn within art institutions, incorporating lectures, guides, conferences and websites would go some way towards including the neglected cognitive and intellectual aspects of disability, and thus extending the possibilities for access. Cachia also argues for the issue of

---

194 The V&A in London for example, which has been offering special talks and touch tours for visually impaired visitors since 1985, in 2004 instituted a Disability Action Plan to extend its access to incorporate tactile books, audio descriptions and special talks for visually impaired visitors (Ginley, 2013).

disability to be tackled via a focus on the actual representation of disability and the artwork of disabled artists, as opposed to a narrow understanding of access for people with impairments as a practical issue of opening doors to audiences excluded by virtue of the particulars of their embodiment (Cachia, 2013).

Since touch is a neglected aspect of peoples' sensory experience of artworks in galleries, and is limited to a blind and visually impaired audience, Georgina Kleege makes the interesting complementary proposal that art institutions seek input from these visitors with regard to their experience. Such an approach would acknowledge blind and visually impaired patrons as having something to offer other than passive gratitude for the opportunities afforded them (Kleege, 2013).

The consensus amongst these and other writers on this topic is that the terms 'access' and 'inclusion' need to be understood in a far broader way, that incorporates a dialectics of reciprocity (Levent, Kleege & Muyskens Pursley, 2013). In fact, the blind artist and accessibility activist Carmen Papalia points out that the issue of access actually goes further than disability:

... my poor visitor experience is not unique to me as a disabled person, it is unique to me as a museum visitor. A lot of museums these days promote inequality, and this inequality is reinforced by the few ways that the museum chooses to make itself accessible to the people who live in the communities that surround it (Papalia, 2013).

## Translation III: Voyage



### Archival thing: the travelling microscope

The Museum Objects catalogue describes a 'Travelling microscope in wooden

box, lid lined with green velvet. Birmingham: R Field and Son, no.386. Microscope 14cm high; box 8.5x14cm. D5744, Rev Jeffcoat. Belonged to F. G. Percy and used by him when he accompanied C Darwin on the voyage of the “Beagle”.

This miniature brass microscope, on the face of it an artefact unproblematically epitomising the empirically-based scientific model of Enlightenment knowledge production, during the course of my research came to speak of much more. Firstly, via a lapse in curatorial care, it came to stand for the chaos lurking just behind the well-contained archival facade, in this case a chaos exceeding ‘fragmentation or dispersion ... inaccessioned documents or the traces and leftovers of organising systems ... torn and missing pages and fragile bindings’ (Hamilton and Skotnes, 2014:23), and leading inexorably to the aporic dead end of lost material.

Roughly eight months into my research, I was notified that the large cardboard box containing various things belonging to the collection, including the travelling microscope had mysteriously vanished. Though I was assured that it had simply been misplaced, and was bound to re-appear, it only resurfaced in 2013, two years into my research process. As a result of this loss, I did not make a version of this artefact for *Hoard*.

Once the microscope re-appeared, though, I decided that it was not too late to work with it; and it was only subsequent to my production of *Translation III: Voyage*, and its display on my exhibition that the next set of unexpected associations came into view, when I discovered that the information in the archive about the microscope’s provenance is inaccurate.

The British zoologist Frederick Gordon Pearcy cited as the original owner of the microscope is remembered as a taxidermist and general assistant to the biological laboratory on board the HMS Challenger during the expedition of 1872–1876 (Science Photo Library, n.d.), which set out scientifically to examine the Earth’s ocean floor.<sup>195</sup> The data collected on this expedition was subsequently

---

195 According to the website of the Birch Aquarium at the Scripps Institute of Oceanography at UC San Diego, ‘Challenger’s scientific objectives were: to investigate the physical conditions of the deep sea in the great ocean basins (as far as the neighborhood of the Great Southern Ice Barrier) in regard to depth, temperature, circulation, specific gravity and penetration of light; to determine the chemical composition of seawater at various depths from the surface to the bottom, the organic matter in solution and the particles in suspension; to ascertain the physical and chemical character of deep-sea deposits and the sources of these deposits; and to investigate the distribution of organic life at different depths and on the deep seafloor’ (Birch Aquarium at the Scripps Institute of Oceanography, n.d.).

compiled into a 50-volume report by the expedition leader, Wyville-Thomson (Birch Aquarium at the Scripps Institute of Oceanography, n.d.).

Though 1857, the only given birth-date I could discover for Pearcey is possibly incorrect, as it would imply that he was aged only 15 when the voyage began, it is clear that he *was* a member of the Challenger expedition. Conversely, he (and thus obviously, the travelling microscope) could certainly not have travelled on the Beagle with Darwin, as this voyage took place from 1831–1836 (Leff, 2008).

This glaring inaccuracy, like the incorrect provenance ascribed to the Rhodes mask in the archive, exposes just how easily misconceptions and inaccuracies can enter into archival records, and even worse, how easily they can remain undetected for decades once they have been written into the finding aids as fact.

If this microscope was indeed used on the Challenger, it is interesting to contrast its current archival status, and, as it were, its personality within the archive as a singular item tucked modestly into its little box, with its provenance. Once, long ago, the miniature brass microscope was one tiny element in a vast host of things of many descriptions, ranging in size from enormous to tiny, used in the course of the expedition. According to a letter written by sailor Joseph Matkin on November 22 1872, at the beginning of the voyage,

We have two Steam Boats on board, and about 30 miles of deep sea line, and dredging line, the other six boats we shall take in when we go into the river next week. All the Scientific Chaps are on board, and have been busy during the week stowing their gear away. There are some thousands of small air tight Bottles, and little boxes about the size of Valentine boxes packed in Iron Tanks for keeping specimens in, insects, butterflies, mosses, plants etc. There is a photographic room on the main deck, also a dissecting room for carving up Bears, Whales, etc. — Letter written by Ship steward's assistant Joseph Matkin (Birch Aquarium at the Scripps Institute of Oceanography, n.d.).

Seen in this light, the miniature microscope ceases to speak only for itself, a quirky, unassuming little artefact with an interesting past related to the pursuit of scientific knowledge, and instead voices loss: in this instance, the loss of a veritable mountain of material that has long since dispersed or disintegrated, and can now only be imagined. There is also a further loss — the loss of any

information about exactly where the microscope was used, and what material was looked at through its lenses.

However, the timing of yet another loss, in this case the temporary loss of the microscope itself within the archive, delayed my research process, so that at the time of my production of *Translation III: Voyage*, this information had not yet surfaced. As a result, in the artwork, I focused on the sensorial effects of the microscope as the shadow it had been during the months it had been missing, in combination with the shadow of the ship it had travelled on.

### ***The artwork: Translation III: Voyage***

In its form, the shadow piece *Translation III*, took inspiration from the artwork 'Schattenspiel' or 'shadow play' by Hans-Peter Feldmann (2009).

This compelling work consists of 12 individual components, each made up of a bright light source and a selection of old toys, rotating on a small square pedestal. These elements are displayed on a 20 foot long table against a parallel wall of the same length, so that their shadows continuously move, grow, shrink and morph into one another (Designboom, 2012).

*Translation III* featured the slowly-rotating shadows of two model sailing ships, one mass produced and made in China, and the other one of a few hand-made out of sheet metal by an unknown artist in Cradock. The two ships were attached to a circulating mechanism in a small room adjacent to the main gallery space, and with the help of a strong light placed just inside a metal tube, their shadows were projected from behind an obviously old, slightly tattered and yellowed curtain, which became the screen or ground for their wavering, looming, rise and fall, appearance and disappearance. On the bottom left hand corner of the screen formed by the curtain, the shadow of a wire interpretation (or translation)

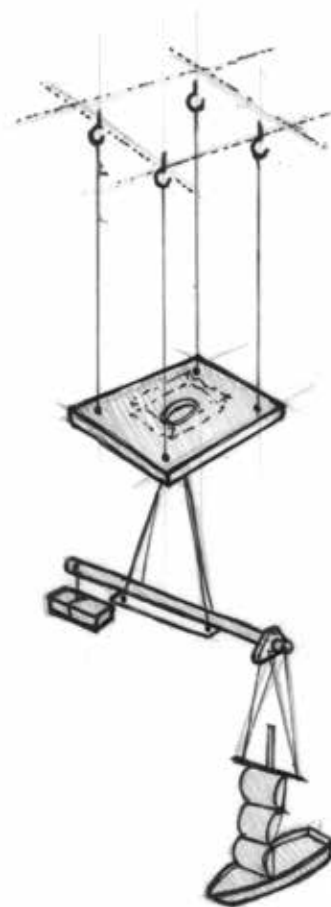

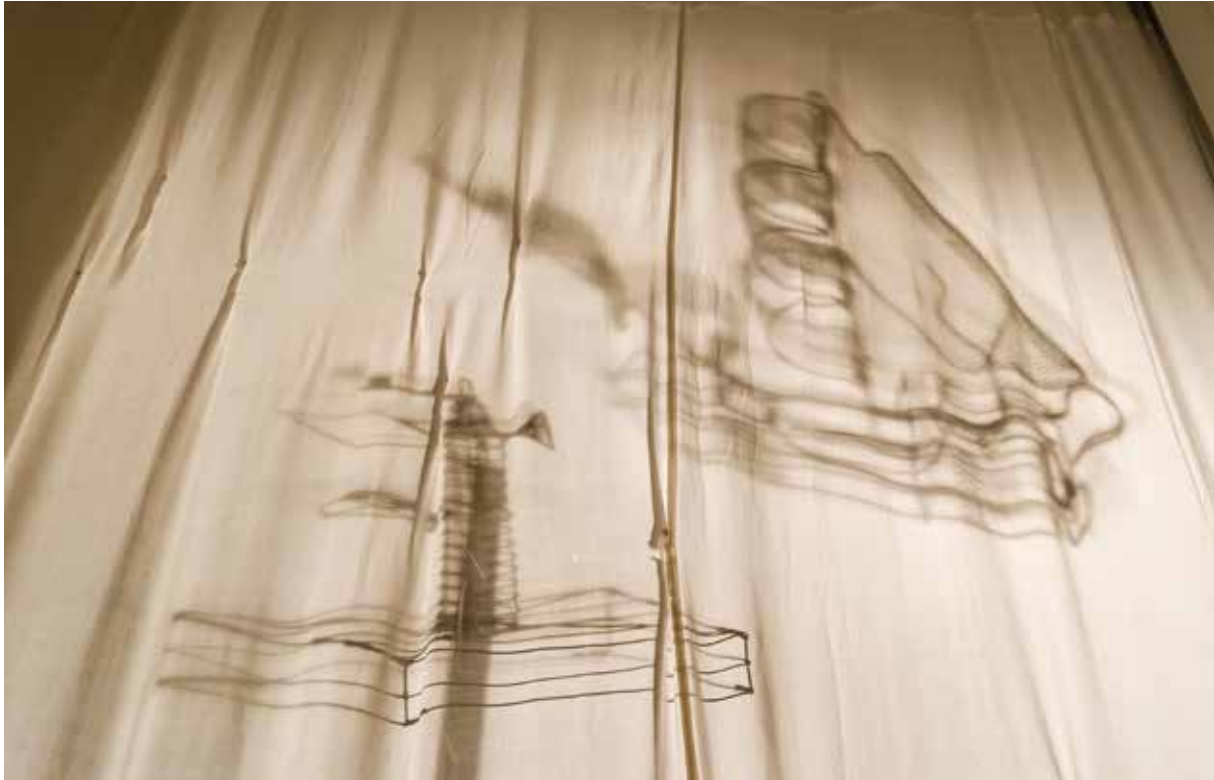

of the microscope in the archive, produced by the locally-based wire artist Brian Hove, was visible.

In an article calling for an anthropological methodology that actively embraces the sensory world view of the Other via the anthropologist's active participation, Yolanda van Ede asserts that such a methodology inevitably implies the rejection of the narrow positivist form of science that has dominated Western knowledge production since the Enlightenment, and that persists to this day. Van Ede notes that interest in the sensorium has burgeoned across disciplines in recent years (Van Ede, 2009:61).

My intention with *Translation III* was to subvert the rigidly scientific approach referred to by Van Ede, and instead consciously explore a less linear and more intuitive form of knowing than is usually applied to the contents of archives, as well as in scholarship conceived of more broadly. Though I chose not to jettison visuality, but instead to make use of a literally more shadowy way of seeing that references, but in no way replicates my own experience of seeing differently through impairment, as with the artworks on *Slantways* that employ the senses of smell, touch and hearing, this work tries to suggest that more creative and flexible epistemological approaches can be effective within the archive.

## Satellite Exhibit

For the small satellite exhibit of a selection of the things from the object collection, I opted for the plainest possible display strategy, simply laying the artefacts out on white card in one of the wood-and-glass display cases used both in the library and in the foyers of academic departments across the university, and on which the four cases custom-made for the display of the artefacts making up *Hoard* were based.

Via this strategy, I wished to some degree to mimic the form a library exhibit is most likely to take, based on the many I have seen in the library over the past five years. I chose to inject only one slightly idiosyncratic element into the display, namely, a set of numbers handwritten onto masking tape squares with the same type of black felt-tipped pen as I had used in *Finding Aid: the archive partially seen*. Each of these numbers was then stuck onto the glass top of the cabinet above a particular artefact. These numbered things were then described in a finding aid typical of the Manuscripts and Archives Department, typed onto A4 sheets of white paper and attached to the cabinet by string.

The only other overt reference to my own exhibition was a poster advertising it, which the library staff displayed next to the exhibit. As the poster



featured the work *Homage to Mr Immelman*, my presence as a contemporary version of Mr Immelman, both him and not him, resonated subtly with the library exhibition, which was almost, but not entirely, simply just that — a display of the artefacts free of references to my own present-day work with the artefacts from the object collection.

There were several factors influencing my choice to hold this display of some of the elements of the object collection in the library simultaneously with *Slantways*. Firstly, the idea of giving these neglected things some exposure appealed to me. Since Immelman's day, this had happened only rarely — for Skotnes, Langerman and Van Embden's exhibition *Curiosity CLXXV*, in 2004, and subsequently on *Imperfect Librarian* in 2012, discussed in relation to *Hoard* above.

Secondly, as discussed at the beginning of this chapter, though I wished the focus of my exhibition to be artwork that responded to the object collection rather than the object collection itself, I did not want the things' role in the assemblage that was my exhibition to disappear from view entirely. My hope was that by displaying them more or less as they typically might be displayed by the library staff, I might potentially create in the viewer a sense of how the artwork brought out further resonances — resonances that are far less accessible without the imaginative responses allowed for by a creative process.

At the same time though, to insistently return the viewer's attention to the collection of things displayed so simply in the library where they are conserved was to draw attention not only to their own mismatched eccentricity as constituent parts of an archival collection, but also to their status as part of that archive in the library, hopefully inviting further consideration of that archive itself.







# CONCLUSIONS

Conventionally, the role of the archive in providing researchers with ‘facts, data and evidence’ from primary sources is cited as its chief characteristic (American Archives month, 2007). In the context of the university, itself typically understood as an all-encompassing structure for the collection, organisation and dissemination of knowledge, the pervasiveness of this understanding guarantees that the archive is recognised as an integral part of that structure.

This conceptual frame is effectively naturalised by its own ubiquity, so that, both its epistemological biases and limitations as well as the possibility of different approaches are largely hidden. The result is that, although the archive has many other potentially generative features, researchers very seldom engage with them in the interests of knowledge production.

In this project, I set out to test the proposition that accessing the archive from a series of oblique angles would throw it into relief and reveal both, its silences and omissions as well as some of its different, less visible aspects. I consider three of these oblique or slantways methodological approaches as central in the project: firstly, using my own visual impairment positively, as an active means to access the archival material from a different perspective, rather than hiding it and understanding it as disadvantageous or even incapacitating; secondly focusing on a marginalised object collection that lacks any taxonomy, thus defying the conventions governing most university as well as most archival collections, and facilitating me to do the same in my research; and thirdly, using a set of creative strategies to engage the collection, as opposed to the reading and writing usually employed by researchers within archives.

I will consider the conclusions enabled by each of these strategies below. In addition, I will discuss several other inter-related conclusions that emerged via the research and creative processes I undertook in the project. These include the blurring of the epistemological boundaries understood to exist between library, archive and museum at the university; the valorisation of university collections without a taxonomy; my conception of the actancy of archival artefacts and how the body of work I produced for this project ‘speaks back’ to the archive — that is, its effects in relation to and within a university experiencing major contestations with regard to its processes of transition to an equitable institution embracing forward-thinking epistemologies and curricula.

## **i. The disabled body as actant**

The considerable personal investment required to produce a PhD makes it likely that the candidate's subjectivity will, at least to some degree, influence the form taken by the work. I think this has been particularly pertinent in my own case, when unforeseeable circumstances, in the form of the untimely onset of visual impairment, abruptly made it imperative radically to re-orientate myself to the material under examination as well as to the processes of art-making, if the project was to proceed.

In a world disinclined to inclusivity, it is commonly the case that the onset of disability heralds an inevitable marginalisation on many fronts. Paradoxically, though, for this project I was able to use my visual impairment to guide me to a methodological strategy enabling a different form of archival access, based on the adoption of a non-ocular and/or multi-sensorial approach. In other words, the incorporation of my disability into my creative methodology enhanced the work I was able to make by enabling a set of new strategies that, in my estimation, added to the impact of the work, in ways that I will discuss below.

On another level, including my disability as a fundamental aspect of the project affirms a commitment to a form of research in which my own subjectivity is understood not as neutral, but as a factor influencing how and why I do what I do. This approach overturns the notion that both researcher and research are value neutral prevailing in Enlightenment — based forms of knowledge production. Instead, it asserts that the perspectives of a usually marginalised subjectivity are able to open up avenues of interrogation and knowledge production disallowed for by the notion of neutral research, in particular, in this case, the affective and sensorial dimensions of experience (see below). This approach might have a broader interest in the current call at the university for the de-colonisation of knowledge.<sup>196</sup>

In more personal terms, the production and exhibition of a viable body of work served to affirm and centre rather than render useless my disabled body, to use its incapacity as capacity. This aspect of the project confirms the productive power of art, bringing to mind Alfred Gell's formulation of art as

---

196 According to Walter D. Mignolo, 'The introduction of geo-historical and biographical configurations in processes of knowing and understanding allows for a radical re-framing (e.g. de-colonization) of the original formal apparatus of enunciation' (Mignolo, 2009:4).

a sphere of human activity in which ‘... all the emphasis ... [is placed] ... on agency, intention, causation, result and transformation’, and art is understood as ‘... a system of action intended to change the world rather than encoded symbolic propositions about it’ (Gell, 1997:6). In this instance, I understand this ‘transformation’ to refer to a form of personalised activism, in which my own art production increases my sense of agency and allows me (as a visually impaired person) to effect positive changes in my world — or more strictly speaking, my experience of the social milieu I inhabit.

## **ii. Working with a marginalised object collection to expose the limits of taxonomy**

By working with a neglected object collection within an archive in which paper-based materials are heavily prioritised, I was able to avoid being restricted by the taxonomic conventions of the archive. Instead, freed from a previously imposed system of ordering, and confronted with a peculiar, mismatched assortment of things randomly grouped together, I was able to encounter the material in front of me without preconceptions. This facilitated a creative process based strongly on engaging with the things, as it were on their own terms, via what they conveyed about the experiences that added to their lives as material artefacts and, in some cases, their entanglements with various individuals both before and after being accessioned into the archive. This thing-centred approach facilitated my understanding of the actancy of the things I worked with that I mobilised for the project, influencing me sometimes directly, for example in terms of the materials I chose to work with and the conceptual issues I chose to address, and also in a more general way, in terms of my conception of the project as an assemblage. I will discuss these issues of actancy in more depth below.

At the same time, the lack of classification in this collection served very clearly to reveal the limitations of the taxonomic order imposed on the other collections, which divides materials into separate silos, and by instituting these divisions, discourages any idea of interactions across these silos, and the cross-medial and/or interdisciplinary approach that such interconnections promote. Furthermore as Fred Wilson’s 1992 artwork *Collection of Numbers* discussed in Chapter Three cleverly emphasises, the pursuit of the implementation of such

systems of cataloguing can very easily come to dominate and even eclipse the material they refer to.

### **iii. Understanding university collections differently**

#### ***Rethinking the boundaries between museum, library and archive***

The in-depth exploration of the archive and its processes that was a part of my encounter with this 'taxonomy-free' collection revealed interesting inconsistencies in the larger taxonomic divisions conventionally assumed to hold sway, in the form of the indistinct and, over the course of the years, shifting nature of the boundaries prevailing between museum, archive and library at UCT. These conditions date back to the opening of the Manuscripts and Archives Department in 1957, and have prevailed to various degrees ever since. This is not to suggest that the archivists and librarians concerned have been sloppy or inconsistent in their custodianship. Rather, a variety of intersecting factors are at play here, including the lack of a formal institutional museum, financial and spatial constraints, the nature of some of the material, which defies the prescriptions for its control and the different interests and emphases of different individual departmental managers over the years.

Since current thinking regards the disciplines as far less rigidly divided than was traditionally assumed, it is now common practice at universities to combine the approaches taken by different disciplines in the interests of gaining a varied set of perspectives, thereby encouraging 'critical dialogue between the disciplines on complex topics that are beyond the resources of individual disciplines alone' (Davies & Devlin, 2007:4). I contend that the interstitial spaces set up by the relative permeability of boundaries referred to above present a fertile terrain for this kind of interdisciplinary research and study in the university context. In particular, this is a distinctly generative location for creative cross-medial projects such as my own, with innumerable possibilities for different sorts of engagements not, as yet, exploited in the context of South African universities.

My research in the Cory Library at Rhodes University in 2012 revealed a similar ambiguity in terms of the divisions between these technologies of the control, storage and dissemination of knowledge (though this has played out in

different ways, with the absorption of the contents of a small museum into the library in the late 1990s). The Wits Archive's *Weird and Wonderfals* exhibition, as well as email correspondence with the archivist at The Nelson Mandela Metropolitan University (NMMU) suggest that at these institutions too, the notion of drawing clear distinctions between archive, museum and library is somewhat (though not absolutely) artificial. These similarities suggest that the opportunities described above exist at other South African tertiary institutions too.

### ***Valorising non-discipline-specific university collections***

The nature of the collection I worked with for this project testifies to the fact that universities are often home not only to object collections relating to specific disciplines, but also to collections associated with no discipline in particular. Such collections are not always found in archives or libraries — at UCT Medical School, for example, a variety of historical artefacts are scattered through the departments, and are understood to be decor, relics or memorabilia. My research has led me to believe that these artefacts have more value than is currently realised. Working with artefacts creatively and outside of pre-imposed taxonomies enables them to leave behind the limitations imposed on them by conventional notions of what they are and the history they are associated with. Instead, as they enter into the present moment via artworks, viewers accord them a different form of attention, unencumbered by pre-existing conceptions. This makes it far more difficult simply to gloss over the complexities of their lives as things and the history they relate to. Consequently, these accumulated things may be enabled to reveal unexpectedly fruitful information about the institution, its archive and its history. With these possibilities in mind, such collections are potentially as valuable as discipline-specific collections.

#### **iv. Using art to trouble the university archive**

For this project, via a series of creative tactics, I subverted and disrupted familiar conventional, conceptions of the archive, so as to invite different understandings of the artefacts, their histories and the university archive to

emerge.

Below I list these tactics, and then tease out the series of inter-related conclusions that they suggest, before commenting further on the question of the artworks' meanings.

### ***The interrogation of how value is ascribed in the archive and the (sometimes illogical) ways in which archival custodianship functions***

By producing a faux-gold 'imposter' collection in the artwork *Hoard*, I pointed to the way in which, once anything is accessioned into the archive, irrespective of its monetary value or known provenance, it automatically and unquestioningly is understood as being worthy of conservation for the foreseeable future. In *Hoard*, the inclusion of elements from both the celebrated, internationally-known Mapungubwe collection as well as from my own personalised home archive 'flattened out' the continuum of value that might conventionally be applied to ascertain the worth of particular things, serving further to expose the ironies of the attribution of value within the archive. In underscoring these ironies inherent in the assignation of value in the archive, the work points to the hidden contingencies and constructed nature of the archive more generally, suggesting that nothing about it is value-free, although it might appear to be so.

### ***A disruption of established notions of taxonomy***

By absorbing the elements from the Mapungubwe collection and my own eccentric personal archive into this 'imposter' collection, as well as by choosing to impose my own personalised scale and finish on the new collection, I also imposed a totally new (ironically more cohesive) taxonomy on the 'imposter' collection, thereby suggesting that the inflexibility of conventional notions of cataloguing in relation to archival collections masks innumerable, equally valid ways of understanding and displaying collections. In addition to personalised taxonomies like my own, that unreservedly bring the idiosyncrasies of the individual displaying the collection to bear on the display, such strategies might include the use of size, shape, colour, materiality or function, or they might even be resolutely arbitrary. Arguably, any of these taxonomic strategies has the potential to inspire closer attention to the artefacts and the history they relate to: by confounding expectations, they expose the constructed

nature of conventional taxonomic systems. In other words, by revealing the diversity of options available, quirky taxonomies reveal the diversity of possible understandings too.

***Questioning the processes of entanglement between people and other people, people and things and across different times that occur within and between different archival collections, both within a particular archive and between the archives of different institutions***

While the conventional notion of the archive as a system for facilitating the gathering and storage of facts and evidence referred to above sets limits on what it has to offer researchers, these complex entanglements imply that the archive has the potential to reveal more than the historical evidence neatly encapsulated in particular collections, and conventionally viewed through the lens of a particular discipline. By following different strands through the archive and across archives, new senses of history, less dominated by previously instituted grand narratives, may be enabled.

As mentioned in Chapter Four, this was the case in my research into the chip of wood associated with David Livingstone, which led me unexpectedly to the image held in the Kimberley Museum, of the colonial servant who cut down the tree from which the wood was gouged. The discovery of this image enabled me, in the artwork I ultimately made, to speak to the broader issues of exclusion from the archive in a way that would not have been possible had I not pursued this particular archival entanglement.

***The enactment and visual representation of disruptive parodic performances in performative work, in which I inserted my own subjectivity into extant historical photographs***

Re-inventing the photographs in this manner institutes a challenge to their original subjects' understanding of the societies in which they lived, and their place in it as white imperialist (in the case of Livingstone and Rhodes) ruling class males. Further, it serves to question the hidden structures of legitimation that supported the powerful subject positions these men inhabited.

Arguably, via this approach, viewers cannot help but be implicated — the insertion of a contemporary woman in drag into the historical photograph calls

for a double-take, and by bringing the image into the present, encourages them to adopt a more personal ethical relationship to history. For white South African viewers, this potentially includes recognition of the likely collusion of their own ancestors (like mine) in the racialised power relationships of the colonial era. This in turn represents a more active engagement with the effects of those relationships in the present moment.

***Making an oblique allusion to the alternative future that might have been the result of a different history***

Both in the three performative collages discussed above, as well as the translation and performance in The Queen's speech, what it is to break down the binaries between fact and fiction, real and imagined, history and what might have been, is explored through imagining alternative histories that then in turn propose a different present.

This re-animates, to paraphrase Walter Benjamin, their obscured and dormant potentiality as missed opportunities, and invites viewers to imagine how they might feel now had their national history as well as the history of UCT been different.

***Pointing to the lack of fixity of meaning within the archive, the alteration in status of archival artefacts across time, and the fluidity of the archive in terms of unpredictable losses and recuperations of material***

The mutability of the archive and its holdings, which flies in the face of any notion of the archive as a timeless bastion against the uncertainties associated with the passage of time, often results from political and ideological shifts in the society that the archive both reflects and influences, or even from changes in the global political zeitgeist (for example, a rise in consciousness of the scale of injustice and human rights violations associated with colonialism). Within the archive, the emphasis in terms of collecting policies and regimes of care may also shift considerably, according to factors such as the temperament and interests of successive cohorts of staff members. One consequence of these differing emphases may include the loss of the institutional knowledge accumulated by a particular staff member on his or her retirement.

My research brought to light how easily misconceptions and inaccuracies

can be transferred into archival records, and once they have entered the finding aids as fact, remain undetected for decades. Material may sometimes be misplaced, lost or even conceivably stolen, pointing to shortcomings in the supposedly unassailable systems of custodianship prevailing in the archive. On the other hand, there is always the possibility that research will reveal inaccuracies, that can then be corrected,<sup>197</sup> and material that was lost may re-appear again.<sup>198</sup>

Significantly, these shifts in the status of archival things also reflect back into the university, playing a part in influencing the constant revisions to which scholarly understandings of the past are subject.

***Commemorating a subaltern colonial subject, whose existence is only marked in the archive as a result of work he undertook in relation to a famous colonial missionary and explorer***

By radically changing the presentation of the image a staff member of the Kimberley Museum had sent me of Askari Musa, I also altered its visual impact and enabled it to present a neglected colonial subject in a way that differed markedly from the image's original effect as a small black-and-white photograph dating from the early 1900s.

The alteration activated by this process challenges the rigid typecasting that, through a discriminatory racialised framing, denied humanity to such subjects under colonialism and apartheid — a bias that is reflected to some degree in the material accessioned into the Manuscripts and Archives Department until the second half of the 1970s. By making and exhibiting an artwork that commemorates an unknown African servant as a human being rather than for his associations to a more important imperial celebrity, I evoked the multiple histories excluded from the archive. This restorative action calls attention to the danger of an unconscious acceptance of the status quo within the university archive, and of a resultant associated acceptance of these absences, which can easily be kept in place by an unthinking adherence to institutional conventions passed down from one cohort of staff members to the next.

---

197 As happened in terms of the provenance of the 'deathmask' in my project.

198 As was the case in my project with the travelling microscope.

***Exploring the sense of hearing, and the place of sound in relation to the silent record held in the Manuscripts and Archives Department***

By instituting a restorative gesture in the direction of listening in the artwork *The Queen's Speech*, I highlighted the deprioritising and, arguably, even neglect within the university archive of the potential of sound for academic research. This lack of emphasis in turn reflects the relative absence of such research into the place of sound and hearing in the cultures of the global South that has prevailed until very recently, representing a series of opportunities at both levels for further research.

To listen to recorded speech or song inevitably allows for the apprehension of performative and affective dimensions that are not available in transcription, adding a valuable layer to the deeper understanding of that speech. In addition, archival sound collections relating to the global South are often associated with colonial ethnographic study of subject populations, in which recordings were undertaken within highly racialised disciplinary contexts. As a result, contemporary attention to sound in the archive often implies a disruptive interrogation of that archive itself — which again may be considered of value in the current call for the decolonization of the university.

***Addressing the issue of sight impairment and seeing differently in both the artwork, as well as in the display strategy I put into place for my exhibition, 'Slantways'***

This tactic allowed me to discuss issues of access directly as they affect people with disabilities within the archive, as well as in relation to institutions such as art galleries and museums. Further, on a metaphorical level, this tactic enabled me to reference accessing the archive differently, in ways not governed by the strictures of forensic research, as part of the process I undertook to show the constructed nature of the archive, and how its limitations exclude many other possible approaches.

***Exploring the senses of smell and touch in relation to the archive and its artefacts***

Both the fleeting and intangible nature of sensorial experience, as well as the

convention of prioritising reading and writing in the archive almost entirely excludes the consideration of the sensorial dimensions of archival material. As a result, creative work designed to be experienced sensorially effectively opens up a different form of understanding that incorporates these potent subjective experiential dimensions, suggesting that there is more to knowledge than what can be accessed via the scrutiny of facts.

***Exploring the affective qualities embedded in particular archival things, such as Mary Brown's expressed nostalgia in the case of the cloth addressed by Olive Schreiner, or the deep affinity of a long-term relationship, in the case of Ray Alexander's hairbrushes***

Like sensory experience, affect is conventionally deprioritised (and often ignored) within the archive; but through my work I suggest that emphasising such qualities allows for a broadening both of knowledge itself, and of what we understand knowledge to be. So, for example, if its affective dimension is embraced rather than ignored, Ray Alexander's hairbrush commands attention to the extent that it speaks of an intimate relationship, in which over a period of many years, a man repeatedly and ritually brushed a woman's hair. Even if this history remains unknown, the artefact resonates strongly with everyday human experience. As for the hairs caught in its bristles, they speak of a whole range of feelings, from distaste to love to melancholy, depending on who is engaging with it.

***Using the play of moving shadows in the work 'Translation III: Voyage' both as part of the metaphor for different forms of sight, as well as to explore a less linear, more intuitive form of knowing than is usually used to access the contents of archives, as well as in scholarship conceived of more broadly***

The aim of this work was speculatively and symbolically to represent an epistemological approach other than the scientific mode characterising Enlightenment knowledge production that currently dominates within the archive and the university. As such, it references the need for a radical shift towards different forms of knowing, so that, as Walter Mignolo puts it, the terms rather than the content of the conversation are altered (2009:4). In this, it speaks to the intense interrogation and critique of the curriculum and the

epistemological assumptions that govern it that have prevailed at UCT in 2015.

***Staging an intervention in the archive at the same time as my exhibition, in the form of a display of a selection of the Manuscripts and Archives object collection, in which no particular taxonomic conventions were followed, and emphasis was simply placed on the arrangement of the material***

This satellite exhibition marked the first time that these artefacts were shown in the archive itself for many years. My hope was that, after visiting my exhibition, viewers would have felt encouraged to see this one, or vice versa. However, the fact that the satellite exhibit stayed up for many months after *Slantways* had ended, meant that the act of displaying these artefacts, even without reference to the artwork, served thoroughly to expose the collection in all its shabbiness and with all its contradictions to the public gaze, and invite an imaginative consideration of the history embodied in these artefacts without reference to outdated and partial historical narratives. Such scrutiny, in turn, invites an act of further consideration of the archive as a whole, allowing for the exposure of its contingencies and biases, and calling into question its claims to objectivity, full inclusivity and longevity, as the comprehensive store of knowledge upon which, at least in part, the university bases its standing as an educational institution.

### ***Meanings and beyond meanings***

As I have previously emphasised, to produce a seamless, unambiguous body of work was neither my intention, nor probably even possible in this project. In fact, one of the main characteristics of the artworks I did make is their multivalence — in producing them I made no claim to provide direct or simple answers to the questions I raised in relation to the archival things I worked with the archive in which they are housed or the histories with which they are entangled. Thus the works' meanings often overlap and in some cases, even contradict each other.

I conceive of these ambiguities as part of the challenge I undertook to explore the artefacts from as many angles as possible, to approach them with subtlety, to entertain the possibility of paradoxical and multiple understandings of the archive and of the history it represents, rather than simply one dominant one. Via the artwork I produced, my intention was also to extend these

challenges to my viewers, to invite them to engage with the archive to which the artworks respond in a considered and complex way that takes into account its own complexities and ambiguities.

Lastly, in terms of the use of artwork to respond to the archive, beyond the ambiguities of the meanings enumerated above, for me it is important to bear in mind the implications of Simon O' Sullivan's contention that art requires more than a straightforward 'reading' process. He explains that

... art is ultimately irreducible to signification and indeed to any discursive account given of it (something always remains — an excess — after any written/spoken report) ... the aesthetic, as I am using the term, names art's specificity as art — its operation up and beyond signification. Such art, we might say, is not just "meaningful", or, not only an object of knowledge (although it is that too) (2010:190-191).

As I see it, it is through this 'excess' marking the oxymoronic intangible specificity of art that an artist-researcher working with creative processes gains the power to speak in different ways from those forensic methods conventionally used by researchers in the archive. It is also as part of this inexplicable 'excess' that the affective and sensuous resonances of the artwork emerge and exert their effects — effects that are directed 'forward' to the viewer but also 'backward' to the archival things the work is responding to.

#### **v. Actancy and things in the archive: the thing called Rhodes**

In the fifth year of this project, on 3 March 2015, UCT student Chumani Maxwele hurled a bucket of human excrement at the bronze Marion Walgate statue of Cecil John Rhodes, which, despite sporadic protests over the years, since 1934 had held prime position on Upper Campus, at the base of the long flight of stairs leading up to Jameson Hall.

This action, intended as a protest against institutional racism and lack of transformation at the university, served as the catalyst for the dynamic and well-supported Rhodes Must Fall campaign, which as its first demand called for the immediate removal of the statue. Just over a month after the initial incident, on 9 April 2015, the statue was hoisted from its plinth and hauled off into an obscure, unspecified storeroom to await further deliberations on its

fate. This campaign had national<sup>199</sup> repercussions, inspiring the defacing and mutilation of several other colonial-era commemorative statues around the country,<sup>200</sup> as well as a heated debate on how public statuary originating during the colonial and apartheid years should best be dealt with in a post- apartheid South Africa (Quintal, 2015).

The Rhodes Must Fall campaign reveals much in terms of the actancy of material artefacts. Although the campaign is ongoing, with the emphasis on transformation within all university structures,<sup>201</sup> so that the removal of the offending statue was perceived of only as an initial step in the right direction, the Walgate sculpture's power to provoke responses and catalyse action is telling.

Over its 81 years on campus, the statue must surely have provoked the full gamut of responses. As an artwork, it may, at least in its early years, have been admired as the manifestation of Walgate's sculptural skill. Ideologically, in the aftermath of the cult of Rhodes, it must have stood for what were once considered as Rhodes's glorious achievements as a leader and imperialist visionary — at least by the ruling classes. Pragmatists in the university administration, realising the ongoing financial benefits of Rhodes's endowment and legacy, may simply have understood it to be a necessary evil (and possibly, to them, not very evil at that). Since at least the 1980s, and particularly more recently, for many people it stood for the tyranny, pain and injustice of colonialism, and for its ongoing effects in our damaged society. In accordance with these extremes, responses have included reverence, the playful yet subversive spirit that inspired students to dress it up on Heritage Day in 2007,<sup>202</sup> the indifference of scores of more privileged members of the university community, an undercurrent of hostility and lately, the sheer rage that led to it being despoiled and held up as '... a deep insult, a symbol of all that is wrong

---

199 The campaign was also cited as inspiring the American protest action that led to Bree Newsome's arrest in late June 2015, after she removed the Confederate flag from the state house in South Carolina, USA. As part of the same wave of protest action, a statue of Columbus in Boston was also defaced (Peterson, 2015).

200 These included a statue of King George VI at the University of KwaZulu-Natal, a Boer war horse memorial and a statue of Queen Victoria in Port Elizabeth, a statue of Paul Kruger in Pretoria and one of Louis Botha outside Parliament in Cape Town (Smith, 2015).

201 According to the Rhodes Must Fall website, 'The Rhodes Must Fall Movement is a collective movement of students and staff members mobilising for direct action against the reality of institutional racism at the University of Cape Town... While this movement may have been sparked around the issue of the Rhodes Statue: the existence of the statue is only one aspect of the social injustice of UCT. The fall of "Rhodes" is symbolic for the inevitable fall of white supremacy and privilege at our campus' (Rhodes Must Fall, 2015).

202 Students calling themselves 'The Kultural Upstarts Kollektive' dressed the sculpture in a giant pair of sunglasses, a makarapa and a Kaiser Chiefs uniform (Duane, 2014).

with UCT and with South Africa — the failure of racial transformation, the power of white privilege, and the persistence of racial subordination’ (Hodes, 2015).

The many chapters of this saga — which is likely to continue beyond 2015 — underline the fact that as a material artefact, whether it is considered as an ‘object’ or ‘thing’ in the traditional uses of these words, as an ‘artwork’ and/ or as a ‘memorial’, the Walgate sculpture had and has actancy in the world it is part of. The failure on the part of UCT Management to reckon with its ability to initiate change cost them severely in terms of the image they sought to project of a postcolonial institution wholeheartedly embracing transformation.

The Rhodes Must Fall Campaign affected the Rhodes ‘deathmask’ in the archive too (irrespective of the fact that it is not a real deathmask). Shortly after the start of the campaign, it was felt politic to remove the Rhodes ‘deathmask’ from the satellite display I had set up in the foyer of Special Collections about six months earlier as part of *Slantways* referred to above. Clearly the library staff felt that the neglected ‘ugly old thing’, as a representation of Rhodes’s hated face, had to be removed from the public eye during the volatile period of protest action at the university.<sup>203</sup>

In other words, the ‘deathmask’ has the potentiality to affect and even conceivably to effect change in the world outside the archive. One of the starting points for the way I chose to work in this project is my contention that, to a greater or lesser extent, at different times and in different ways, this is the case with all of the things making up the object collection. In other words, archival artefacts have actancy.

This conception is not new; in fact the removal of the ‘deathmask’ from the display as a response to the protest action on campus accords perfectly with Hamilton’s conception of the agency of archival holdings, referred to in Chapter One. According to this view,

Archival collections are reframed and refashioned over time, subject to the ebb and flow of reinterpretation, and in turn affecting interpretation. Thus it is that the archival object, perhaps more accurately, archival subject, charts a course

---

203 Meyer explained that this was part of a broader strategy to make public all material relating to the debate and to the campaign, without Special Collections staff taking sides (Renate Meyer, email correspondence, 13 July 2015).

over time, lived in a continuous relationship with an ongoing, changing context, sometimes exerting a form of agency. (Hamilton, 2013:11-12).

In this formulation, the agency of the archival thing emerges from the dialectic it is engaged in with the broader society; so that social, political and ideological changes in the world outside the archive, as well as (sometimes resultant) changes in academic discourse and the development of knowledge affect the archival object and are in turn affected by the history it bears testimony to, and the information it is able to reveal.

While this continuing interaction is certainly an essential aspect to the actancy of archival objects,<sup>204</sup> for the purposes of this creative project, my own approach to the things' actancy is somewhat broader. Following Bennett, as well as my own intuitions and sensibilities as a long-time collector and artist, the artefacts' actancy also rests on other innate qualities.

These include the media from which they are made. Since, as Bennett reminds her readers, '... even the humblest forms of matter and energy have the potential for self-organization beyond the relatively simple type involved in the creation of crystals' (Bennet, 2010:7), these sensuous qualities are a direct expression of the things' innate vitality or energetic force as a particular material or combination of materials. These material energies play out in ways both obvious and more subtle in artworks in which things are a central feature, as discussed in Chapters Two and Four.

In this project, I also discussed another aspect of the things actancy, namely the range of their often less quantifiable, for me sometimes unpleasant, sometimes melancholy innate qualities. These include their shabbiness, their troublesome feel of neglect and decay, and the stain of the colonial past they bear. These aspects influenced me in sometimes subtle, sometimes more overt ways, including the desire they inspired to engage with them wholeheartedly in all their taintedness, to allow them to reveal their stories in potentially unexpected ways.

As a final step in the conception of actancy I used for this project, I combined the three aspects of the things' actancy referred to above — the continuing interactions between archival things and the world outside the

---

204 This was in fact the chief aspect of the actancy of the 'deathmask' that I sought to play with in the work *Rhodes un-deathmasks i-vi*.

archive, and the power conferred by the particular materiality and media of the artefacts — with a fourth form of actancy. Again following Bennett, I also understand actancy in this project as being embodied in an ontologically varied assemblage, in which the archival things, human actants, the process of making and ultimately the final artworks all worked together to produce a combined effect in the form of my exhibition, *Slantways*.

As an artist, I understand the strength of this fifth approach to the things' actancy to lie in its unbalancing of the notion of the artist as human creator with power over a set of inert and mute — in fact lifeless — archival artefacts, to that of artist as co-producer, working within an assemblage of human and non-human actants to 'co-create' a set of responses via a series of artworks that, adding their own actancy as material things, are able to question the archive and reveal it differently.

## **vi. An archive that speaks to the present**

The issue of actancy aside, there is a second way, too, in which the Rhodes Must Fall campaign is of the utmost relevance to this project. The anger, energy and determination unleashed by this campaign reveals with great clarity the unavoidable truth that, 21 years after the advent of democracy in South Africa, transformation remains, at best, a hotly-contested work in progress at UCT.

According to Professor Njabulo Ndebele, 'There can be no transformation of the curriculum, or indeed of knowledge itself, without an interrogation of archive' (APC, 2015). This argument strongly suggests that, as well as the obvious need for debate and concerted attention to policy, the range of responses to the imperatives of real transformation need to include a critical assessment of the archival legacy upon which the institution was founded.

As the fracas around the Walgate sculpture demonstrated, a failure adequately and thoroughly to address the university archive will certainly have further consequences; and although there was general agreement that the removal of the sculpture, as a potent symbol of centuries of racist oppression was long overdue, there is a strong argument for a subtler critical approach to the complex palimpsest of archival material testifying both to oppression and to resistance, to shifts over time signifying a more inclusive approach, as well as to the inevitable continuing effects of the past on the present moment. This can

only take place in the context of an open, honest and imaginative examination of that archive, one that does not shy away from but rather seeks to expose and examine its taintedness, contradictions and complexities in the interests of building a more just and equitable present.

In this context, I believe that creative interventions such as the one I undertook for this project have a role to play in opening up the archive in ways that potentially engage students and scholars to assess the material they speak of with enough subtlety to allow an array of meanings and implications to emerge, no matter how convoluted, ambiguous or incomplete. How far the university is prepared to go in embracing such creative interrogations and critiques of its archive is a moot point. Here I can only speak for my own project and the space of critical engagement it now occupies as a body of work that aimed to engage creatively with the UCT archive via its object collection.

In this regard, it is noteworthy that, despite the lack of priority accorded to the artefacts in the Manuscripts and Archives Department on the UCT library website I discussed in my introduction, in June 2014 the current manager of Special Collections, Renate Meyer, delivered a speech in which she referred to some of the things from the collection and the stories they tell (Swingler, 2014). Furthermore, since early 2014, new care is being taken with the conservation of the artefacts, which are now housed in individual custom-made acid free boxes. In late 2015, Meyer informed me of her intention to display all the 'museum objects' in the Special Collections strongroom, so that researchers will more easily be able to view the artefacts as a collection (Renate Meyer, personal communication, 19 November 2015). It is not immodest to say that these developments are in some part the result of the exposure accorded to the object collection through this project.

In terms of the artwork itself, through its iteration on the South African Pavilion at the 55th Venice Biennale, my imposter collection, *Hoard*, with its allusions to both the UCT archive and larger issues of South Africa's complex inheritance, gained considerable exposure on an international fine art stage. Additionally, the work's inclusion in the *Imaginary Fact* catalogue firmly situates *Hoard* in a broader continuing discussion of the South African archive, and this catalogue's online presence gives *Hoard* the potential to be encountered by an even larger international audience. In this way, the Manuscripts and Archives object collection gained further meaning, a degree of relevance or, at the least,

a new spark of interest in the contemporary moment.

Closer to home, at UCT itself and obviously on an incomparably humbler scale, in September 2014, through my exhibition, *Slantways*, I tried to create a similar effect, by inviting viewers at UCT to apply their imaginative powers to rethink both the collection and the archive the exhibition responded to.

In a cultural milieu swamped by an abundance of production, most art exhibitions are ephemeral events, whose effects on their viewers are difficult to gauge. This fleeting quality is particularly striking in relation to an exhibition that sought to explore the archive, which in manifest contrast usually evokes notions of continuing stability. It was my hope that the overall 'feel' of the exhibition, expressed via the artworks' combined invocation of sensory and affective realms, their appeal to the imagination in relation to our history and inheritance and their use of creative cross-medial translation, would to some degree infuse the viewers' sensibilities, and remain with them as traces that might allow them to apprehend the archive both more vividly and more fluidly long after the exhibition ended.

Also in September 2014, the UCT Works of Art Committee expressed a definite interest in purchasing *Hoard*, but stipulated that the sale cannot be concluded before my PhD has been assessed. Although I subsequently offered to loan the work to the library until the sale goes through, in the hope that it would be displayed in the vicinity of the collection and archive it responds to and examines, the library staff declined this offer on the basis that all the available space in Special Collections is taken up with various pieces of antique furniture.

It remains to be seen whether this sale will go through, and if it does, whether the work will be displayed in the context it directly references, which would, in a sense, underscore the critical enquiry it embodies. However, the fact that the University Works of Art Committee minuted a discussion with regard to my proposal that UCT purchase the work (Fritha Langerman, email correspondence, 12 October 2015) means that it has entered the record, again adding further meaning to the life of the collection that inspired its production.

## WORKS CITED

"Administer, v." *Merriam-Webster Dictionary online*. n.d. Available: <http://www.merriam-webster.com/dictionary/administer> [2015, August 28].

Ahmed, S. 2006. *Queer phenomenology: orientations, objects, others*. Durham: Duke University Press.

American Archives Month, 2007. *What Is An Archives?* Available: <http://files.archivists.org/advocacy/AAM/WhatIsAnArchives.pdf> [2015, October 5].

Archive & Public Culture, 2015. Available: <http://www.apc.uct.ac.za/> [2015, October 15].

Appadurai, A. 1986. Introduction: commodities and the politics of value. In *The social life of things: Commodities in cultural perspective*. A. Appadurai, Ed. Cambridge: Cambridge University Press. 3-63.

ARC. n.d. *About ARC: The visual university and its columbarium*. Available: <http://www.arc.uct.ac.za/about/more/> [2015, August 17].

Artspace, 2014. *How the art world caught archive fever*. Available: [http://www.artspace.com/magazine/art\\_101/art\\_market/the\\_art\\_worlds\\_love\\_affair\\_witharchives-51976](http://www.artspace.com/magazine/art_101/art_market/the_art_worlds_love_affair_witharchives-51976) [2015, June 1].

Bal, M. 1994. Telling objects: a narrative on collecting. In *The culturing of collecting*. J. Elsner & R. Cardinal, Eds. London: Reaktion Books Ltd. 97-115.

Bal, M & Morra, J. 2007. Editorial: acts of translation. *Journal of Visual Culture*. 6(1): 5-11.

Bambanani Group. n.d. *What are body maps?*. Available: [http://www.memorybox.co.za/index.php?option=com\\_content&task=view&id=16&Itemid=37](http://www.memorybox.co.za/index.php?option=com_content&task=view&id=16&Itemid=37) [2015, February 15].

Batchen, G. 2004. Ere the substance fade: photography and hair jewellery. In

*Photographs, objects histories: on the materiality of images*. E. Edwards & J Hart, Eds. London: Routledge. 32-46.

Baudrillard, J. 1996. *The system of objects*. Translated by James Benedict. New York: Verso Books.

Baudrillard, J. 1998. *The consumer society: myths and structures*. Translated by Chris Turner. Thousand Oaks, California: Sage Publications Ltd.

Benes, B. L. 2002. *Curiosa: celebrity relics, historical fossils & other metamorphic rubbish*. New York: Harry N. Abrahams Inc. Publishers.

Benjamin, W. 1969. *Illuminations*. Translated by Harry Zohn. New York: Schocken Books.

Benjamin, W. 1996. *Selected Writings Volume 1 1913-1926*. Ed. Marcus Bullock and Michael W. Jennings. Cambridge, Massachusetts and London: The Belknap Press of Harvard University Press.

Benjamin, W. 2002. *The Arcades Project*. 3<sup>rd</sup> ed. Cambridge, Massachusetts: The Belknap Press of Harvard University Press.

Bennett, J. 2010. *Vibrant matter: a political ecology of things*. Durham: Duke University Press.

Bennett, J. 2011. *Artistry and Agency in a World of Vibrant Matter | The New School* [Video file]. Available: <https://www.youtube.com/watch?v=q607Ni23QjA> [2015, May 5].

Besser, H. 2004. *The museum-library-archive*. Available: <http://www.nyu.edu/tisch/preservation/program/04spring/chin-libraries.html> [2014, October 26].

Bierbaum, E. G. 1990. Beyond Print: Object Collections in Academic Libraries. *Collection Building*. 10(1/2):7-11.

Birch Aquarium at the Scripps Institute of Oceanography. n.d. *The science: Introduction*. Available: [http://aquarium.ucsd.edu/Education/Learning\\_Resources/Challenger/science.php](http://aquarium.ucsd.edu/Education/Learning_Resources/Challenger/science.php) [2015, January 15].

Bleek and Lloyd Collection. BC151, A5.6. Manuscripts and Archives Department, University of Cape Town Libraries, University of Cape Town. (Unpublished).

Blom, P. 2002. *To have and to hold. An intimate history of collectors and collecting*. London: Penguin Books.

Bogues, A. 2010. *Speech by Professor Anthony Bogues at the Special Commemorative Session of the UN General Assembly*. New York, 25 March 2010. Available: <http://www.mona.uwi.edu/cct/speech-professor-anthony-bogues-special-commemorative-session-un-general-assembly> [2015, September 2].

Boshoff, W. 2004. *Nonplussed*, exhibition catalogue, 22 May – 19 June, Goodman Gallery, Johannesburg.

Bounia, A. 2004. *The nature of classical collecting: collectors and collections, 100 BCE - 100 CE*. Hampshire: Ashgate.

Brady, H. 2015. *Art as national identity: Jasmina Cibic and Slovenia at the Venice Biennale*. Available: <http://theculturetrip.com/europe/slovenia/articles/art-as-national-identity-jasmina-cibic-and-slovenia-at-the-venice-biennale/> [2015, March 15].

Brown, M. 1955. *Olive Schreiner: memories of a friendship*. Cape Town: Pioneer Press.

Brown, B. Ed. 2004. *Things*. Chicago: University of Chicago Press.

Brown, B. 2010. *The nature of things* [Video file]. Available: <http://bigthink.com/videos/the-nature-of-things> [2015, June 8].

Business Insider. 2011. *The weirdest celebrity items to be auctioned off on eBay*. Available: <http://www.businessinsider.com/weird-ebay-auctions-celebrities-2011-7?op=1> [2015, September 3].

Byala, S. G. 2013. *A place that matters yet: John Gubbins's MuseumAfrica in the postcolonial world*. Chicago: University of Chicago Press.

Cachia, A. 2013. Talking blind: disability, access, and the discursive turn. *Disability*

*Studies Quarterly*. 33(3). Available: <http://dsq-sds.org/article/view/3758/3281> [2015, July 10].

Campbell Collection of the University of KwaZulu-Natal. n.d. *Killie Campbell: Biographical essay*. Available: <http://campbell.ukzn.ac.za/?q=node/43> [2015, September 3].

Centre for African Studies. 2015a. *African Studies Gallery*. Available: <http://www.africanstudies.uct.ac.za/gallery> [2015, August 15].

Centre for African Studies. 2015b. *About Centre for African Studies at the University of Cape Town*. Available: <http://www.africanstudies.uct.ac.za/about%20> [2015, August 18].

Centre for Curating the Archive. 2015a. *Curiosity CLXXV*. Available: <http://www.cca.uct.ac.za/projects/curiosity-clxxv/> [2015, August 10].

Centre for Curating the Archive. 2015b. *About the CCA*. Available: <http://www.cca.uct.ac.za/about/> [2015, August 20].

CJ Sibbett Papers. BC50. Manuscripts and Archives Department, University of Cape Town Libraries, University of Cape Town. (Unpublished).

Clark, P. 2004. "Better libraries for everyone!": the development of library services in the Western Cape in the 1940s. *Innovation*. 28(1):22-30.

Connor, S. 2004. *The book of skin*. London: Reaktion Books Ltd.

Connor, S. 2013. *Paraphernalia: The curious lives of magical things*. London: Profile Books Ltd.

Coetzee, J. M. 1988. *White writing: on the culture of letters in South Africa*. New Haven: Yale University Press.

Cornell University Division of Rare & Manuscript Collections. 2004. *The New Game of Human Life*. London: John Wallis, 1790. Available: <http://rmc.library.cornell.edu/games/promoting/4.html> [2015, January 29].

Corrin, L. G. Ed. 1994. *Mining the museum: an installation by Fred Wilson*. New York: The Contemporary in cooperation with the New Press, New York.

Counsell, C. 2009. Introduction. In *Performance, embodiment and cultural memory*. C. Counsell & R. Mock, Eds. Newcastle upon Tyne: Cambridge Scholars Publishing. 1-16.

Csordas, T. J. 1990. Embodiment as a paradigm for anthropology. *Ethos: Journal of the Society for Psychological Anthropology*. 18(1):5-47. DOI: 10.1525/eth.1990.18.1.02a00010.

Csordas, T. 2011. Cultural phenomenology. Embodiment: agency, sexual difference, and illness. In *A companion to the anthropology of the body and embodiment*. F. E. Mascia-Lees, Ed. Chichester, West Sussex: Wiley Blackwell. 137-156.

Cvetkovich, A. 2003. *An Archive of Feelings: Trauma, Sexuality, and Lesbian Public Cultures*. Durham & London: Duke University Press.

Cvetkovich, A. 2012. *Ann Cvetkovich, "The Queer Art of the Counterarchive"* [Video file]. Available: <https://www.youtube.com/watch?v=pefn1BI9bOE> [2015, June 24].

Danbolt, M. & Spieker, S. 2014. Roundtable on the critical archive. *ARTMargins*. 3(3):3-20. DOI:10.1162/ARTM\_a\_00091.

Daston, L. 2004. Introduction: Speechless. In *Things that talk: object lessons from art and science*. L. Daston, Ed. New York: Zone Books. 9-26.

Davies, M. & Devlin, M. 2007. *Interdisciplinary high education: Implication for teaching and learning*. Melbourne: The University of Melbourne. Available: [http://www.cshe.unimelb.edu.au/resources\\_teach/curriculum\\_design/docs/InterdisciplinaryHEd.pdf](http://www.cshe.unimelb.edu.au/resources_teach/curriculum_design/docs/InterdisciplinaryHEd.pdf) [2015, July 10].

De Jong, F. & Harney, E. 2015. Art from the archive. *African Arts*. 48(2):1-4. DOI:10.1162/AFAR\_a\_00211.

Deleuze, G. & Guattari, D. 1987. *A thousand plateaus*. Translated by Brian Massumi. Minneapolis: University of Minnesota Press.

Designboom, 2012. *Hans Peter Feldmann: shadow play at HangarBicocca, Milan*. Available: <http://www.designboom.com/art/hans-peter-feldmann-shadow-play-at-hangarbicocca-milan/> [2015, September 3].

Designboom, 2013. *The 387 houses of Peter Fritz at the Venice Art Biennale*. Available: <http://www.designboom.com/art/the-387-houses-of-peter-fritz-at-the-venice-art-biennale/> [2015, May 12].

Dodd, A. 2014. *Secular séance: Post-Victorian embodiment in contemporary South African art*. PhD thesis. University of Cape Town.

Dominy, G. 1999. The politics of museum collecting in the 'old' and the 'new' South Africa. In *Museums and the future of collecting*. Knell, S. Ed. Aldershot, Hampshire, Great Britain: Brookfield, Vt. & Ashgate. 135-145.

Dorment, R. 2009. *Fabiola: Francis Alys at the National Portrait Gallery*. Available: <http://www.telegraph.co.uk/culture/art/art-reviews/5345000/Fabiola-Francis-Alys-at-the-National-Portrait-Gallery.html> [2015, June 28].

Drobnick, J. 1998. *Reveries, assaults and evaporating presences: olfactory dimensions in contemporary art*. Available: <http://www.david-howes.com/senses/Drobnick.htm> [2015, August 16].

Drobnick, J. 2005. Volatile effects: Olfactory dimensions of art and architecture. In *Empire of the senses: The sensual culture reader*. Howes, D. Ed. Oxford: Berg. 265-280.

Drew, J. 1981. The university archives in retrospect and prospect. *Jagger Journal*. University of Cape Town. (2): 42-46.

Duane, J. 2014. *Cecil Rhodes, heritage formation and contemporary popular culture*. Available: [http://www.archivalplatform.org/blog/entry/cecil\\_rhodes/](http://www.archivalplatform.org/blog/entry/cecil_rhodes/) [2015, June 12].

Duchemin, M. 1983. Theoretical principles and practical problems of respect des fonds in archival science. *Archivaria*. (16):64-82. Available: <http://journals.sfu.ca/archivar/index.php/archivaria/article/viewFile/12648/13813> [2015, August 25].

Erlman, V. 2004. But what of the ethnographic ear? *Anthropology, sound and the*

senses. In *Hearing cultures: essays on sound, listening, and modernity*. V. Erlman, Ed. Oxford: Berg. 1-20.

Eco, U. 2009. *The Infinity of Lists*. Translated by Alastair McEwen. London: Maclehorse Press.

Edwards, E. & Hart, J. 2004. Introduction: photographs as objects. In *Photographs objects histories: on the materiality of images*. E. Edwards & J. Harts, Eds. London: Routledge. 1-15.

Erdmann Contemporary, n.d. *Self Portrait Project 2007/2013 expanded series*. Available: <http://www.erdmanncontemporary.co.za/nomusa-makhubu/self-portrait-project-20072013-expanded-series/> [2015, September 1].

First, R. & Scott, A. 1980. *Olive Schreiner: A biography*. London: André Deutsch.

Foster, H. 2004. An archival impulse. *October*. Fall 2004(110):3-22. DOI:10.1162/0162287042379847.

Frow, J. 2001. A pebble, a camera, a man who turns into a telegraph pole. *Critical Inquiry*. 28(1): 270-285.

Gale, I. 1995. *Visual arts Tilda Swinton Serpentine Gallery, London*. Available: <http://www.independent.co.uk/arts-entertainment/visual-arts--tilda-swinton-serpentine-gallery-london-1599685.html> [2015, June 3].

Gell, A. 1998. *Art and agency*. Oxford: Oxford University Press.

George Glazer Gallery. n.d. *Wallis's Map Game of England and Wales*. Available: <http://www.georgeglazer.com/archives/maps/archive-europe/wallisbritgame.html> [2015, January 29].

Gibson, J. J. 1979. *The Ecological Approach to Visual Perception*. Boston: Houghton Mifflin Company.

Gibson, M. 2010. Death and the transformation of objects and their value. *Thesis Eleven*. 103(1):54-64. DOI: 10.1177/0725513610388988.

Ginley, B. 2013. Museums: A whole new world for visually impaired people. *Disability Studies Quarterly*. 33(3). Available: <http://dsq-sds.org/article/view/3761/3276> [2015, May 15].

Ginsberg, E. 2012. *Case study: Mining the museum*. Available: <http://beautifultrouble.org/case/mining-the-museum/> [2015, July 15].

Gioni, M. 2013. *The Encyclopedic Palace*. Available: <http://www.labiennale.org/en/art/archive/55th-exhibition/gioni/> [2015, June 12].

Guasch, A. M. 2011. Art and Archive, 1920-2010. *Genealogies, typologies and discontinuities*. Available: <http://globalartarchive.com/anna-maria-guasch/recent-work/art-and-archive-latin-america-and-beyond/> [2015, August 28].

Hamilton, C. 2011. Backstory, biography, and the life of the James Stuart Archive. *History in Africa*. 38(1):319-341. DOI: 10.1353/hia.2011.0015.

Hamilton, C. 2013. Forged and continually refashioned in the Crucible of Ongoing Social and Political Life: Archives and Custodial Practices as Subjects of Enquiry. *South African Historical Journal*. 65(1):1-22. DOI: 10.1080/02582473.2013.763400

Hamilton, C. & Skotnes, P. 2014. Introduction. In *Uncertain curation: in and out of the archive*. C. Hamilton & P. Skotnes, Eds. Johannesburg: Jacana Media. 1-23.

Hicks, D. & Beaudry, M. C. 2010. Introduction. Material culture studies: a reactionary view. In *The Oxford handbook of material culture studies*. D. Hicks & M. C. Beaudry, Eds. Oxford: Oxford University Press. 1-24.

Hodes, R. 2015. 'The Rhodes statue must fall': UCT's radical rebirth. Available: <http://www.dailymaverick.co.za/article/2015-03-13-the-rhodes-statue-must-fall-ucts-radical-rebirth/#.VdrD9CWqqkp> [2015, June 11].

Hoffmann, A. 2015. Introduction: listening to sound archives. *Social Dynamics: A Journal of African Studies*. 41(1):73-83. DOI: 10.1080/02533952.2014.983314.

Hoffman, A. & Mnyaka, P. 2014. Hearing voices in the archive. *Social Dynamics: A Journal of African Studies*. 41(1):140-165. DOI: 10.1080/02533952.2014.985467.

Holly, M. A. 2007. The melancholy art. *The Art Bulletin*. 89(1):7-17. DOI: 10.1080/00043079.2007.10786323.

Howes, D. P. 2011. Impairment. Sporting bodies: sensuous, lived and impaired. In *A companion to the anthropology of the body and embodiment*. F. E. Mascia-Lees, Ed. Chichester, West Sussex: Wiley-Blackwell. 276-291.

Howes, D. 2006. Cross-talk between the Senses. *The Senses and Society*. Berg. Vol1:3. 381-390.

Howes, D. 2011. The Senses: polysensoriality. In *A companion to the anthropology of the body and embodiment*. F. E. Mascia-Lees, Ed. Chichester, West Sussex: Wiley-Blackwell. 435-450.

Immelman, R. F. M. 1956. *The library of the University of Cape Town, historical development, 1829-1955. Issued on the occasion of the 50th anniversary of the establishment of the main library 1905*. Rondebosch, Cape Town: University of Cape Town Libraries.

Immelman, R.F.M. 1963. Miss H. Mary White. *The Jaggerite*. University of Cape Town. (21):13-14.

Immelman, R. F. M. 1968. *Handlist of manuscripts in the University of Cape Town Libraries, Volume 1, Varia Series*. Cape Town: University of Cape Town Libraries.

Immelman, R.F.M. 1982. *The Ballot Kicherer Collection in U.C.T. Libraries: the Cape's second-oldest book collection*. University of Cape Town.

Jack and Ray Simons Collection. BC1081. Manuscripts and Archives Department, University of Cape Town Libraries, University of Cape Town. (Unpublished).

Jackson, A. V. 2013. *Archival impulse, 2013*. Available: <http://www.ayanavjackson.com/#!archival-impulse/c10by> [2015, January 15].

Jackson, A. V. 2014. *Ayana V Jackson: Archival impulse, November 13 – December 21, 2014*. Available: <http://33orchard.com/2014/11/01/ayana-v-jackson-archival-impulse-november-13-december-21-2014/> [2015, January 20].

James, A. & Hills, N. Eds. 1937. *Mrs John Brown, 1847 – 1935: an account of her social work in Lancashire and South Africa, of her memories of Lancashire folk, and her friendship with Olive Schreiner*. London: John Murray.

Jeal, T. 2013. Dr Livingstone and the cult of Victorian celebrity. *The Telegraph*. 19 March. Available: <http://www.telegraph.co.uk/history/9937770/Dr-Livingstone-and-the-cult-of-Victorian-celebrity.html> [2015, January 6].

Jeffcoat Collection. BC531. Manuscripts and Archives Department, University of Cape Town Libraries, University of Cape Town. (Unpublished).

Jourdan, P. 1911. *Cecil Rhodes His Private Life by his Private Secretary*. London: J. Lane Publication.

Kashe-Katiya, X. 2013. *Carefully Hidden Away: excavating the archive of the mapungubwe dead and their possessions*. M.Phil thesis, University of Cape Town.

Kear, A. 2006. The memory of promise: theatre and the ethic of the future. In *A performance cosmology: A performance cosmology: testimony from the future, evidence of the past*. J. Christie, R. Gough & D. Watt, Eds. London: Routledge. 148-151.

Kearney, A. 2013. The framing of objects in Penny Siopis' 'Sympathetic Magic': research. *De Arte*. (88):46-62.

Kleege, G. 2013. Some touching thoughts and wishful thinking. *Disability Studies Quarterly*. Available: <http://dsq-sds.org/article/view/3741/3284> [2015, May 8].

Kopytoff, I. 1986. The cultural biography of things: commoditization as process. In *The social life of things. Commodities in cultural perspective*. A. Appadurai, Ed. Cambridge: Cambridge University Press. 64-91.

Kristeva, J. 1982. *Powers of horror: an essay on abjection*. Translated by Leon S. Roudiez. New York: Columbia University Press.

La Biennale di Venezia. 2013. *The Encyclopedic Palace*. Available: <http://www.labiennale.org/en/art/archive/55th-exhibition/55iae/> [2015, August 20].

Landau, P. S. 2002a. Introduction. In *Images and empires: visibility in colonial and postcolonial Africa*. P. S. Landau & D. D. Kaspin, Eds. Los Angeles: University of California Press. 1-40.

Landau, P. S. 2002b. Empires of the visual: photography and colonial administration in Africa. In *Images and empires: visibility in colonial and postcolonial Africa*. P. S. Landau & D. D. Kaspin, Eds. Los Angeles: University of California Press. 141-171.

Langerman, F. 2013. *The exploded book: a disarticulation of visual knowledge systems within sites of natural history display*. PhD thesis. University of Cape Town.

Law, J. 2002. *Sympathetic magic: Penny Siopis at the Gertrude Posel Gallery, University of the Witwatersrand*. Johannesburg: University of the Witwatersrand.

Leff, D. 2008. *HMS Beagle Voyage crossing the Atlantic Ocean*. Available: <http://www.aboutdarwin.com/voyage/voyage03.html> [2015, February 4].

Levent, N., Kleege, G. & Muyskens Pursley, J. 2013. Guest editors' introduction: museum experience and blindness. *Disability Studies Quarterly*. Available: <http://dsq-sds.org/article/view/3751/3252> [2015 June 10].

Levin, L. 2009: The performative force of photography. *Photography & Culture*. 2(3):327-336. DOI: 10.2752/175145109X12532077132473.

Livingstone, J. D. 2014. *Livingstone's life & expeditions*. Available: <http://livingstoneonline.org/life-and-times/livingstone%E2%80%99s-life-expeditions#l1e8> [2014, December 9].

Lucarelli, F. 2012. *Fabiola, a project by Francis Alÿs*. Available: <http://socks-studio.com/2012/07/13/fabiola-a-project-by-francis-aly/> [2015, July 28].

Maart, B. 2013. *Imaginary Fact: Contemporary South African Art and the Archive*. Grahamstown, South Africa: National Arts Festival.

Macdonald, S. Collecting practices. In *A companion to museum studies*. S. Macdonald, Ed. Malden: Blackwell Publishers. 81-97.

Maharaj, S. 2009. Know-how and no-how: stopgap notes on “method” in visual art as knowledge production. *Art & Research: A Journal of Ideas, Contexts and Methods*. 2(2). Available: <http://www.artandresearch.org.uk/v2n2/pdfs/maharaj.pdf> [2015, August 17].

Makhubu, N. 2013. The Power and Terror of the Enactment of Collective Memory in Performative Photography. *Semiha Es – Women Photographers International Symposium*. 26-28 November 2013. Istanbul. (Unpublished).

Mass Observation, n.d. *History of Mass Observation*. Available: <http://www.massobs.org.uk/about/history-of-mo> [2015, July 10].

Maylam, P. 2005. *The Cult of Rhodes: Remembering an Imperialist in Africa*. Cape Town: David Philip.

Mbembe, A. 2002. The power of the archive and its limits. In *Refiguring the archive*. C. Hamilton, V. Harris, M. Pickover, G. Reid, R. Saleh & J. Taylor, Eds. Cape Town: David Phillip Publishers. 19-26.

Mbembe, A. 2005. The place of imagination. In *Penny Siopis*. K. Smith, Ed. Johannesburg: Goodman Gallery Editions. 119-128.

Mbembe, A. 2015. *Decolonizing Knowledge and the Question of the Archive*. Available: <http://wiser.wits.ac.za/system/files/Achille%20Mbembe%20-%20Decolonizing%20Knowledge%20and%20the%20Question%20of%20the%20Archive.pdf> [2015, October 2].

Merleau-Ponty, M. 1964. *The primacy of perception: and other essays on phenomenological psychology, the philosophy of art, history and politics*. Evanston, Illinois: Northwestern University Press.

Meyburgh, T. 2006. *The body remembers: body mapping and narratives of physical trauma*. MA thesis. University of Pretoria.

Mignolo, W, 2009. Epistemic Disobedience, Independent Thought, and Decolonial Freedom. *Theory, Culture & Society* 2009 Vol. 26(7–8): 1–23. DOI: 10.1177/0263276409349275. SAGE, Los Angeles, London, New Delhi, and Singapore.

Miller, P. 2007. *Rewind: a cantata for voice, tape & testimony*. Available: <http://www.philipmiller.info/projects/a-test-project/> [2015, June 1].

Mofokeng, S. n.d. *The black photo album/ Look at me: 1890 – 1950*. Available: <http://cargocollective.com/santumofokeng/black-photo-album> [2015, May 25].

Mundy, J. 2012. *Lost art: Robert Smithson*. Available: <http://www.tate.org.uk/context-comment/articles/gallery-lost-art-robert-smithson> [2015, May 11].

Muñoz, J. E. 1996. Ephemera as evidence: Introductory notes to queer acts. *Women & Performance: A Journal of Feminist Theory*. 8(2):5-16. DOI: 10.1080/07407709608571228.

Musée d'Orsay. 2006. *Last portrait*. Available: [http://www.musee-orsay.fr/en/events/exhibitions/in-the-musee-dorsay/exhibitions-in-the-musee-dorsay-more/page/2/article/le-dernier-portrait-4186.html?tx\\_ttnews%5BbackPid%5D=649&cHash=2e1539861a](http://www.musee-orsay.fr/en/events/exhibitions/in-the-musee-dorsay/exhibitions-in-the-musee-dorsay-more/page/2/article/le-dernier-portrait-4186.html?tx_ttnews%5BbackPid%5D=649&cHash=2e1539861a) [2012, March 15].

Nabokov, V. 1951. *Speak memory: a memoir*. London: Victor Gollancz.

Ncube, G. 2012. Picturing colonial medicine: perspective of patient photography. (Unpublished).

Nixon, M. 2014. Depths of field: photographs and early Southern African music studies. In *Uncertain curation: in and out of the archive*. C. Hamilton & P. Skotnes, Eds. Johannesburg: Jacana. 189-227.

Norton, M. & Wise, E. M. 2004. Staging an empire. In *Things that talk: object lessons from art and science*. L. Daston, Ed. New York: Zone Books. 101-146.

Ntsebeza, L. 2012. African studies at UCT: an overview. In *African Studies in the post-colonial university*. T. Nhlapo & H. Garuba, Eds. Cape Town: University of Cape Town in association with the Centre for African Studies. 1-22.

Nuttall, S. 2009. *Entanglement: Literary and cultural reflections on post-apartheid*. Johannesburg: University of Witwatersrand Press.

- Nyamnjoh, F. B. 2012. Blinded by sight: divining the future of anthropology in Africa. *Africa Spectrum*. 47(2-3):63-92.
- O'Hara, F. 1955. Today. In *The collected poems of Frank O'Hara*. D. Allen, Ed. Berkeley: University of California Press. 15.
- O'Sullivan, S. 2010. From aesthetics to the abstract machine: Deleuze, Guattari and contemporary art practice. In *Deleuze and Contemporary Art*. S. Zepke & S. O'Sullivan, Eds. Edinburgh: Edinburgh University Press. 189-207.
- Olive Schreiner Collection. BC16. Manuscripts and Archives Department, University of Cape Town Libraries, University of Cape Town. (Unpublished).
- Olive Schreiner Letters Project. 2012. *Olive Schreiner: Margaret McNaughton 97.12.3.6.23*. Available: <https://www.oliveschreiner.org/vre?view=collections&colid=138&letterid=3> [2014, December 29].
- Oldenburg, C. n.d. *Large-scale projects*. Available: <http://www.artnetweb.com/oldenburg/scale.html> [2015, July 20].
- Oldenburg, C. & van Bruggen, C. 1995. *Claus Oldenburg Coosje van Brugen: Large scale projects*. London: Thames and Hudson Ltd.
- Pamuk, O. 2010. *The museum of innocence*. New York: Vintage International.
- Papalia, C. 2013. A new model for access in the museum. *Disability Studies Quarterly*. 33(3). Available: <http://dsq-sds.org/article/view/3757/3280> [2015, July 18].
- Payne, T. 2010. *Fame: what the classics tell us about our cult of celebrity*. New York: Picador.
- Perella, C. & Di Majo, E. 2001. *Yinka Shonibare: Be-Muse*. Rome: Museo Hendrik Christian Andersen.
- Perry, G. 2011. *The tomb of the unknown craftsman*. London: British Museum Press.
- Petersen, C. 2015. RMF inspires US activists. *IOL News*. 3 July. Available: <http://www>.

iol.co.za/news/south-africa/western-cape/rmf-inspires-us-activists-1.1880323#.VZpMKOmJjv [2015, July 5].

Phaidon, n.d. *Christian Boltanski's island of death*. Available: <http://uk.phaidon.com/agenda/art/events/2012/march/12/christian-boltanskis-island-of-death/> [2015, August 26].

Phillips, H. 1993. *The University of Cape Town 1918-1948: The formative years*. Cape Town: UCT in association with the UCT Press.

Plotz, J. 2005. Can the sofa speak? A look at Thing Theory. *Criticism*. 47(1):109-118. DOI:10.1353/crt.2006.0006.

Porteous, J. D. 2006. Smellscape. In *The smell culture reader*. J. Drobnick, Ed. Oxford: Berg. 89-106.

Putnam, J. 1999. 'Appointment' – *Sophie Calle, 1999*. Available: [http://www.jamesputnam.org.uk/inv\\_exhibition\\_07.html](http://www.jamesputnam.org.uk/inv_exhibition_07.html) [2015, February 20].

Putnam, J. 2001. *Art and artifact: the museum as medium*. London: Thames and Hudson.

Putnam, J. 2012. *Museum, the artist and 'intervention'*. Available: <http://www.ceramics-in-the-expanded-field.com/essays/james-putnam-gb> [2015, May 20].

Putter, A. 2012. Native work: an artwork by Andrew Putter consisting of 38 portrait photographs (with photography by Hylton Boucher, Kyle Weeks and Andrew Putter). *Kronos*. 38(1): 249-261.

Quinn, G. 1959. Alterations and moves at Jagger. *The Jaggerite*: University of Cape Town. (19):16-17.

Quinn, G. 1961. Manuscripts and Archives Division. *The Jaggerite*: University of Cape Town. (19):25-26

Quintal, G. 2015. Mantashe: You can't take a hammer to history. *News24*. 13 April. Available: <http://www.news24.com/SouthAfrica/News/You-cannot-take-a-hammer->

to-history-Mantashe-20150413 [2015, 19 April].

Raabe, P. 1983. Library history and the history of books: two fields of research for librarians. In *Books and Society in History*. K. E. Carpenter, Ed. New York: R.R Bowker Company. 251-154.

Rhodes Must Fall. 2015. *About*. Available: [http://rhodesmustfall.co.za/?page\\_id=4](http://rhodesmustfall.co.za/?page_id=4) [2015, June 11].

Ricke, A. n.d. *Anthropology of the Senses*. Available: [http://www.indiana.edu/~wanthro/theory\\_pages/senses.htm](http://www.indiana.edu/~wanthro/theory_pages/senses.htm) [2015, January 18].

Rotberg, R. I. 1988. *The Founder. Cecil Rhodes and the pursuit of power*. New York: Oxford University Press.

SA Travel Directory. 2012. *Kuruman, Northen Cape*. Available: <http://sa.travel-directory.co/kuruman/1270> [2012, January 13].

Schmahmann, B. 1998. Casting a glance, diverting the gaze: George Segal's representation of the female body. *American Art*. 12(3):10-29. Available: [http://www.jstor.org/stable/3109314?seq=1#page\\_scan\\_tab\\_contents](http://www.jstor.org/stable/3109314?seq=1#page_scan_tab_contents) [2015, August 8].

Schmahmann, B. 2009. Face-to-face negotiations: portraits of leaders at three South African universities. *De Arte*. (80):14-36.

Schmidt, L, E. 2002. *Hearing things. Religion, illusion and the American Enlightenment*. Massachusetts: Harvard University Press.

Schnapp, J. T. 2001. The Romance of caffeine and aluminum. *Critical Inquiry*. 28(1):244-269. Available: <http://www.jstor.org/stable/1344267> [2015, July 31].

Schoeman, K. 1991. *Olive Schreiner: A woman in South Africa 1855-1881*. Johannesburg: Jonathan Ball Publishers.

Schreiner, O. 1992. *Thoughts on South Africa*. Introduced and annotated by Margaret Lenta. Johannesburg: AD. Donker.

Schwenger, P. 2006. *The tears of things: melancholy and physical objects*. Minnesota: University of Minnesota.

Science Photo Library. n.d. *Frederick G. Pearcey, British zoologist*. Available: <http://www.sciencephoto.com/media/415796/view> [2015, January 15].

Searle, A. 2010. *Christian Boltanski: It's a jumble out there*. Available: <http://www.theguardian.com/artanddesign/2010/jan/13/christain-boltanski-grand-palais-paris> [2015, August 20].

Sekula, A. 1986. The body and the archive. *October*. 39 (Winter):3-64. DOI: 10.2307/778312.

Sheehy, C. J. Ed. 2006. *Cabinet of curiosities: Mark Dion and the university as installation*. Minneapolis: The University of Minnesota Press.

Shoro, K. 2014. *Terms of engaging and project-ing Africa (ns): an ethnographic encounter with African studies through Curate Africa*. MA Thesis. University of Cape Town.

Simon, C. 2002. Introduction: Following the archival turn. *Visual Resources: An International Journal of Documentation*. 18(2):101-107. DOI: 10.1080/01973760290011770.

Skotnes, P., van Embden, G. & Langerman, F. 2004. *Curiosity CLXXV: a paper cabinet*. Cape Town: LLAREC Series in Visual History, University of Cape Town.

"Slantways, adv.". *American Heritage Dictionary of the English Language online*. 2011. 5th ed. Houghton Mifflin Harcourt Publishing Company. Available: <http://www.thefreedictionary.com/slantways> [2015, August 22].

"Slantways, adj.". *Collins English Dictionary online*. 2015. HarperCollins Publishers. Available: <http://www.collinsdictionary.com/dictionary/english/slantwise> [2015, August 22].

Smith, D. 2015. Vandalism of apartheid-era statues sparks fevered debate in South Africa. *The Guardian*. 10 April. Available: <http://www.theguardian.com/world/2015/>

apr/10/vandalism-of-apartheid-era-statues-sparks-fevered-debate-in-south-africa [2015, 11 June].

South African History Online. n.d. *Ray Alexander Simons*. Available: <http://www.sahistory.org.za/people/ray-alexander-simons> [2015, January 19].

South Africa Info, n.d. *Mapungubwe: SA's lost city of gold*. Available: <http://www.southafrica.info/about/history/mapungubwe.htm#.VjMPUMuhfv4> [2015, November 11].

Spivak, G. C. 1994. Can the Subaltern speak?. In *Colonial discourse and post-colonial theory: a reader*. P. Williams & L. Chrisman, Eds. Harlow, England: Longman Publishers.

Steedman, C. 2001. *Dust*. Manchester: Manchester University Press.

Stewart, S. 1993. *On longing: narratives of the miniature, the gigantic, the souvenir, the collection*. Durham: Duke University Press.

Stoler, A. L. 2009. *Along the archival grain: epistemic anxieties and colonial common sense*. Princeton: Princeton University Press.

Swingler, H. 2014. *UCT Newsroom & Publications. Monday Paper archives: Volume 33.05 17 June 2014*. Available: <http://www.uct.ac.za/mondaypaper/archives/?id=9823> [2015, May 10].

Taylor, L. E. 1970. R. F. M. Immelman. In *Libraries and people. Essays offered to RFM Immelman*. J. G. Kesting, S. L. Malan, A. H. Smith & L. E. Taylor, Eds. Cape Town: C. Struik. 1-8.

The Argus. 1947. *University gives Queen an ovation/Degree conferred on Her Majesty/Moving ceremony in Jameson Hall*. The Argus (Cape Town). 22 April:1.

The Atlas Group, n.d. *The Atlas Group archive*. Available: <http://www.theatlasgroup.org/> [2015, May 29].

The Atlas Group. 2006. Let's be honest, the rain helped, 2003. In *The Archive*

(*Documents of contemporary art*). C. Merewether, Ed. London: Whitechapel Gallery. 179-180.

The Conveyor. 2013. *Objects in the lives of writers: 19 September 2013* [Blog, 12 September]. Available: <http://blogs.bodleian.ox.ac.uk/theconveyor/2013/09/12/objects-in-the-lives-of-writers-19-september-2013/> [2015, September 2].

The Hunterian. n.d. *David Livingstone tree*. Available: <http://www.gla.ac.uk/hunterian/collections/collectionssummaries/archaeologyandworldcultures/worldcultures/davidlivingstonetree/> [2014, December 9].

The New York Times. 1902. Death of Cecil Rhodes; The "Empire Builder" Passes Away Peacefully. *The New York Times*. 27 March. Available: <http://query.nytimes.com/gst/abstract.html?res=9C00E5DB1230E733A25754C2A9659C946397D6CF#> [2012, June 24].

The Olive Schreiner Letters Online. 2012. *The Olive Schreiner Letters Online*. Available: <https://www.oliveschreiner.org/> [2015, August 10].

Tickner, L. 2003. A strange alchemy: Cornelia Parker Interviewed by Lisa Tickner. *Art History*. 26(3):364-391.

Thubron, C. 2006. *Shadow of the silk road*. London: Chatto & Windus.

Ullens Center for Contemporary Art. 2012. *Kan Xuan: Millet Mounds*. Available: <http://ucca.org.cn/en/exhibition/kan-xuan-millet-mounds/> [2015, May 29].

University of Cape Town. 2015a. *Archive & Public Culture*. Available: <http://www.apc.uct.ac.za/> [2015, October 8].

University of Cape Town. 2015b. *About the university: Introducing UCT: Our history*. Available: <http://www.uct.ac.za/about/intro/history/> [2015, September 3].

University of Cape Town. 2015c. *Research & Libraries: Libraries*. Available: <https://www.uct.ac.za/research/libraries/> [2015, May 10].

University of Cape Town. 2015d. *Archive & Public Culture*. Available:

<http://www.apc.uct.ac.za/news/listening-sound-archives> [21 October 2015].

Van Ede, Y. 2009. Sensuous anthropology: sense and sensibility and the rehabilitation of skill. *Anthropological Notebooks*. 15(2):61-75.

Varley, D. 1982. Rene Immelman: library pioneer and cape historian. *Jagger Journal*. (3):1-5.

Van Wolputte, S. 2004. Hang on to yourself: of bodies, embodiment, and selves. *Annual Review of Anthropology*. 33(1):251-269. DOI: 10.1146/annurev.anthro.33.070203.143749.

Wapner, J. 2013. Mission and low vision: A visually impaired museologist's perspective on inclusivity. *Disability Studies Quarterly*. 33(3). Available: <http://dsq-sds.org/article/view/3756/3290> [2015, February 2].

Watermeyer, B. 2013. *Towards a Contextual Psychology of Disablism*. London and New York: Routledge.

Watts, B. 1980. The UCT libraries from 1956 to 1965. *Jagger Journal*. University of Cape Town. (1):43-53.

Willem Boshhoff Artist. 2012. *Blind alphabet*. Available: [http://www.willemboshoff.com/documents/artworks/blind\\_alphabet.htm](http://www.willemboshoff.com/documents/artworks/blind_alphabet.htm) [2015, July 9].

Windhorse Publications. 2013. *An interview with Dhivan Thomas Jones, author of 'This Being, that becomes: The Buddha's teaching on conditionality'*. Available: <https://thebuddhistcentre.com/windhorsepublications/interview-dhivan-thomas-jones-author-being-becomes-buddhas-teaching> [2015, July 2].

Whitebread, K. 2009. Renée Green. Ongoing Becomings. Retrospective 1989-2009. *Rebus*. (4):1-13.

Works of Art Committee. 1975-1985. Minutes of meetings. University Archives. University of Cape Town.

World War 1 in Africa, 2014. *What's in a name: A brief history of "Askari"*. Available:

<http://wwiafrica.ghost.io/a-brief-history-of-askari/> [2015, October 7].

Wright, J. 2011. Do not look too hard for meaning. *Metropolitan*. (October): 58-66.

Yeo, G. 2008. Concepts of Record (2): Prototypes and Boundaries. *The American Archivist*. Spring/Summer 2008. (71):118-143.

Zimmer, N. 2015. Percival Kirby's wax cylinders: elegy on archiving a deaf spot. *Social Dynamics*. 41(1):101-123. DOI: 10.1080/02533952.2014.988931.

Zuma, B. 2011. *Michele Pickover*. Available: [http://www.wits.ac.za/newsroom/newsitems/13162/news\\_item\\_13162.html](http://www.wits.ac.za/newsroom/newsitems/13162/news_item_13162.html) [2015, June 16].

# APPENDIX 1

## A brief art autobiography

Though I came to my life as an artist rather circuitously, from my childhood onwards, there was never a time when some form of art-making was not one of my chief preoccupations.

In my early adulthood, I focused on various media, particularly cartooning and photography. During this time, a parallel interest gradually developed: I became more and more engaged with my long-term passion for collecting. This acquisitive desire had been aimed at postcards and stickers in my childhood, and had veered off sporadically and unpredictably in various directions during my twenties. In my early 30s, I finally 'settled' in my collecting, and began to focus in earnest on accumulating cheap, miniature ephemera, usually considered either as worthless junk, or at the best as reserved for the amusement of children: toys, trinkets, key-rings and fridge magnets sourced from lucky packets, egg machines and Christmas crackers, but also from flea markets, R5 emporia, second-hand shops and fetes.

From about 1994 until 2011 when I began my PhD, collecting began to take over, ultimately eclipsing my other creative concerns. Initially as a way to justify my obsession, I developed a form of artwork as an extension of this practice — the production of what I termed 'pinboards.' These consisted of masses of my small things pinned with coloured-headed dressmaker's pins into foam-core boards covered with fabric.

I held my first solo exhibition *Acupuncture*, in 1999 at InSpace in Johannesburg, and at the NSA Gallery in Durban the following year. For that body of work, my strategy was to arrange my little artefacts into different formations according to invented taxonomies, so as to create fields. Though initially the pinboards had been unframed, for the purposes of exhibiting them I chose to display them either in glass-fronted wooden boxes or behind custom-made steel and perspex frames.

On the simplest level, my practice expressed a collector's desire to collect and then classify everything in the world (or its miniature plastic version). Even if logistically this had been possible — which clearly it was not — the very

process of collecting disallows this notion: Baldessari explains in relation to his personalised classification system of movie stills that 'A bargain must always be struck between what is available in movie stills and the concerns I have at the moment — I don't order the stills, I must choose from the menu' (Baldessari, in Wallis 1987:103). In the same way, I chose from the 'menu', and could only classify what I could buy or had been given. These limitations on the process of collecting are obvious, yet the impossibility of the task only added to my fascination.

Particularly in the more chaotic and, in terms of the artefacts displayed, more varied pinboards I also sought to comment on paradoxical or disturbing cultural assumptions and contradictions. This I would do by, for example, placing a miniature plastic palm tree next to a stereotypically represented African dollie, which might suggest the primitivist assumptions lurking beneath the surface of Western notions of 'exotic' African subjects — even (or particularly? ) as they are expressed as plastic trinkets.

Probably the main issue that I sought to confront in these works was how to come to terms with the world of rampant late capitalist consumerism in which we all live.

On this level, much of my work was concerned with the excesses inherent in our consumerist culture. As such it represented an ongoing and insoluble interrogation into my own position in the face of this extravaganza of excess, that co-exists so easily (and so disturbingly) with the other side of the global coin — persistent social, economic and political deprivation and want.

One especially potent aspect of this theme, which relates back to the unworkable desire to collect everything in existence, is that of obsessive greed. The endless availability of cheap, trashy artefacts, both locally and in other countries of the global South, meant that my personal desire for more could never be satiated. On a micro scale, this represents the larger picture of the never-ending production of wave upon wave of consumerist goods, and the concomitant frenzy of consumption that it both feeds and requires.

Arguably, on a certain level, greed is one of the motivating forces for the relentless cycle of production and consumption that lies at the heart of our existence. Here a set of the tiniest, crudest plastic cars can stand in for a millionaire's collection of luxury vehicles; and abandoning the trend for collecting plastic aliens one year in favour of tiny tele-tubbies the next stands

in for the hapless thrall of millions of individuals to the unstoppable yearly re-imaginings and regurgitations of the global fashion industry.

On another level, this work embodied a sense of fetishism — material objects being imbued with some kind of magical quality or power. In my case, this power might relate in some way to issues of memory and time passing. At the same time, the fragile yet constant artefacts I collected, in their gawdy materiality, appealed to me enormously. My desire and effort was to display them in ways that reflected my intimacy with and affection for them as undervalued, but to me, beautiful things.

As mentioned in Chapter Four in relation to *Hoard*, I have considered questions of value and beauty for the duration of my life as an artist. An overarching concern in almost all my pinboard work was the desire to challenge notions of what we commonly consider to be precious and worth treasuring. In acknowledgement of the fact that cheap, mass-produced plastic trinkets and novelties are the only treasures available to the vast numbers of the world's population, my pinboard work sought to comment on and disrupt the categories of 'cheap' / 'trashy' and 'valuable'. In the process, a new cosmology, categorised according to personal criteria, was configured.

My practice evolved and expanded from 2002 to 2003, when I was producing the body of work I presented for *Thingerotomy*, my MA exhibition at the Johannesburg Art Gallery in 2004. I now sometimes made colour fields, and experimented with different densities for different sections of the field. I also used my collected things to write words, sometimes interspersed with fridge magnet letters. So, for example, in one work, I used plastic bones and a set of plastic teeth to spell out the words 'let go' on a black ground. In another, consisting of a large vertical field of variously sized and coloured plastic flowers pinned onto a lime green ground, the lyrics from a famous spiritual, 'When I die, Hallelujah by and by, I'll fly away' are incorporated into the work.

For this body of work I also made use of utilitarian things such as drinking straws and cocktail sticks, as well as materials commonly associated with craft and/or sewing, such as pompoms, lace, braid and sequins. Initially, when I used these materials, the work tended to be more pictorial. In these works, pompoms of different sizes and colours were used to create textured volumes, which I then outlined with mapping pins. I employed this technique to produce versions of three iconic artworks from the canon of 'high art' for this body of

work: Titian's *Venus of Urbino* (1538), Courbet's *L'origine du Monde* (1866), and Gauguin's *Spirit of the Dead Watching (Manao Tupapau)* (1892). In the case of these re-makes of famous artworks, I attempted to ask a question closely linked to my interest in commodification and consumption, namely, how far these once unique images have been devalued by their incessant reproduction. I was also interested in the extent to which the originals could be simplified and schematised and yet remain recognisable as 'high art'.

Later, in 2008, for the exhibition *Monomania* at the Goodman Gallery, Cape Town, I used pompoms far more extravagantly. In the work *The Beautiful adventure*, I pinned pompoms of different colours and sizes into the surface of two sides of an approximately 4m x 2,5m black drywall, to form a wonky grid.

I also first exhibited one of my 'necklace' works on *Monomania*. Each of these consists of a different length of nylon thread, usually closed to form an enormous necklace, made up of various shapes and sizes of coloured beads combined with children's letter beads to spell out different texts. In one instance, this consists of a list of ailments from a pamphlet advertising the services of a traditional healer, while another is made up of a list of every country in the world, and so on. For the *Spier Contemporary* in 2010, I exhibited possibly the most resolved of these works, *Necklace for Tara*, a 1100cm 'necklace' detailing everything I had lost the previous year in a hijacking in Durban.

*Monomania* also saw the first iteration of a parallel, companion collecting obsession that had, as it were, crept up on me: *The People*, discussed in Chapter Four in relation to its third iteration at the Michaelis Gallery in 2012, at a time when I was considering incorporating it into my PhD project. *The People* is a collection of more than 2 000 small plastic humans, humanoids, human-like animals and monsters, plus their accessories — shoes, babies' bottles, food, guns, TV sets and cameras, coke bottles, crates and trucks, petrol pumps, military vehicles, national flags, a railway line, a parking garage and so on. This plethora of figures and artefacts are presented in varying and fluid configurations, so that the people engage in intersecting scenes in which they pose for the camera, chop down trees, get married, play soccer and tennis, slaughter each other and flee from the terror of war.

As discussed in Chapter Four in relation to *Hoard*, this work questions and plays with issues of value. It also refers to the process of collecting,

questions of taxonomy and, as it has no set form and no endpoint as a collection, the limitless possibilities of display. On another level, it tracks international and local technological advancements and cultural phenomena, and their expression in toys over the last 60-odd years, such as changes in toys' materiality, including the different forms of plastic that have replaced each other over the years, the rise of China as a toy producer in tandem with the ubiquity of Disney. It also explores issues of representation, specifically the way in which racial, cultural and gender stereotypes that play an important role in the socialisation of children have been perpetuated over the past 60 years through the toys they play with.

# APPENDIX 2

## Hoard – list of artefacts

### CABINET 1

A tiny bronze sculpture of the Hindu deity Ganesh, bought in the Grey Street area, Durban, 1990s. *Personal collection.*

Echo sounding chart from the maiden voyage of the Swedish transatlantic ship, the Kanangoora, as it passed over the Aliwall Shoal near Umkomaas in 1939. *Manuscripts and Archives Department, UCT.*

Chip of wood from the tree under which David Livingstone proposed to Mary Moffat at the Moffat mission station near Kuruman, in 1840. *Manuscripts and Archives Department, UCT.*

Bottles and tray from the first aid kit taken by dentist Walter Floyd on his hunting trip in the then Northern Rhodesia in 1913. *Manuscripts and Archives Department, UCT.*

Piece of unpolished tiger's eye that belonged to my mother, Una. *Personal collection.*

Leaf from the bodhi tree in Bodh Gaya, India, under which the Buddha became enlightened. *Personal collection.*

Early example of a lead pencil, made from ivory rather than wood. *Manuscripts and Archives Department, UCT.*

Piece of charcoal from an old wooden pencil case. *Manuscripts and Archives Department, UCT.*

Fragment of wood with 'Polarskibet Fram' inscribed on it, from the Fram, the ship used by the Norwegian explorer Fridtjof Nansen in his attempt to reach the North Pole (1893–1896). *Manuscripts and Archives Department, UCT.*

Spectacles picked up on the battlefield at Paardeberg in 1902. Listed in the finding aid but lost, so imagined. *Manuscripts and Archives Department, UCT.*

My own first spectacles, which I began to wear at around age one. *Personal collection.*

Pressed tinfoil eyes used in Hindu prayers. Bought in Chatsworth, Durban, about 2010. *Personal collection.*

21 pieces of a worn cardboard model of the human brain. It belonged to amateur

Cape Town phrenologist J.G. Davidson in the 1950s. It is now too fragile to put together. *Manuscripts and Archives Department, UCT.*

## **CABINET 2**

Little wooden rifle carved by a South African War prisoner. The words 'Boeren Kamp Ceylon 1901 Mauser' are painted on it in tiny, neat gold letters. *Manuscripts and Archives Department, UCT.*

Gavel that belonged to Gideon Brand van Zyl, Governor General of the Union of South Africa from 1945–1950. *Manuscripts and Archives Department, UCT.*

Pen used by Queen Elizabeth when she signed the visitor's book in the UCT library in 1947. *Manuscripts and Archives Department, UCT.*

Horse/bird-headed oil lamp. Part of the collection donated by Catholic clergyman Monsignor Kolbe (1854–1936). *Manuscripts and Archives Department, UCT.*

A tiny, blobby plastic baby, which I made rather larger than the original. *Personal collection.*

Blue wooden block with a wonky cross drawn on it by some child, possibly me. *Personal collection.*

Real gold rhinoceros from the Iron Age Kingdom of Mapungubwe, Limpopo. *Mapungubwe collection, University of Pretoria.*

Wooden cross donated by Catholic clergyman Monsignor Kolbe. *Manuscripts and Archives Department, UCT.*

Silver cross. One of several in the archive. *Manuscripts and Archives Department, UCT.*

Grey stone with a natural white cross on it that used to live outside my mother's front door in Observatory, Cape Town. *Personal collection.*

Miniature Bible, written up as 'the smallest printed Bible in the world' and dated 1950. *Manuscripts and Archives Department, UCT.*

Real gold, glass and plastic beads. *Mapungubwe collection, University of Pretoria; Manuscripts and Archives Department, UCT and personal collection.*

Real gold bowl from Mapungubwe, the largest kingdom on the subcontinent in the 12<sup>th</sup> and 13<sup>th</sup> Centuries. *Mapungubwe collection, University of Pretoria.*

Lucky beans from the tree 'Erythrina caffra', collected in 2012 in Plumstead, Cape

Town, and umkhokha, from the creeper 'Abrus precatorious' collected from the Durban Botanic Gardens in the 1990s. *Personal collection.*

Real gold sceptre. *Mapungubwe collection, University of Pretoria.*

9-Carat gold spoon. I have replaced its South African College crest with a hint of the protea that was on the spoon I ate with as a tiny child. *Manuscripts and Archives Department, UCT.*

Five medals, representing the many UCT and other medals in the collection. *Manuscripts and Archives Department, UCT.*

My mother's gold bracelet, which she always wore on her upper arm during my childhood. *Personal collection.*

Ceramic handle from the Kolbe collection. *Manuscripts and Archives Department, UCT.*

### **CABINET 3**

Worn cardboard hexagon and the letters A B C and F from an alphabet game. *Manuscripts and Archives Department, UCT.*

Hexagon crocheted by my grandmother Susie Heyns, as part of an unfinished blanket. *Personal collection.*

Piece of calico cloth addressed in Olive Schreiner's hand. It wrapped the manuscript of 'The Story of an African Farm' when she sent it to England for publication in late 1879/ early 1880. *Manuscripts and Archives Department, UCT.*

A set of hand-made ivory letter counters that fit into a cylindrical ivory box. *Manuscripts and Archives Department, UCT.*

A pair of dice from a shoebox full of them. *Personal collection.*

Two flat carved wood and string Victorian puzzles. *Manuscripts and Archives Department, UCT.*

Antique S-shaped coat hook possibly dug up from one of the Port Elizabeth municipal rubbish dumps during the bottle-hunting craze of the 1970s. *Personal collection.*

64 wooden counters that live in a small drawstring bag. *Manuscripts and Archives Department, UCT.*

Crumpled, faded pink silk tie. No provenance available. *Manuscripts and Archives*

*Department, UCT.*

Frogs from the Victorian game 'Frogs and Toads'. The tiny originals are made from lead and enamel. *Manuscripts and Archives Department, UCT.*

Hairbrush and hand mirror that belonged to trade unionist Ray Alexander.

*Manuscripts and Archives Department, UCT.*

15<sup>th</sup> Century letter from an English woman to her husband. *Manuscripts and Archives Department, UCT.*

Blue and red sash with gold fringes. Part of the ceremonial regalia of the Newlands Friendly and Benevolent Society. *Manuscripts and Archives Department, UCT.*

Brown leather belt with a brass buckle worn by the poet C. L. Leipoldt during World War I when he was on the personal staff of General Louis Botha. *Manuscripts and Archives Department, UCT.*

Keys representing those used to open the trunks in which the archival material was kept when the department came into being in 1958. *Manuscripts and Archives Department, UCT.*

## **CABINET 4**

Gold-topped walking stick given to C. H. Van Zyl by the Khedive of Egypt in the early 1900s. *Manuscripts and Archives Department, UCT.*

Odds and ends from trade unionist Ray Alexander's trinket box. *Manuscripts and Archives Department, UCT.*

Record of the speech made by Queen Elizabeth when she received her honorary PhD from UCT in 1947. *Manuscripts and Archives Department, UCT.*

Small canvas handbag embroidered in pastel shades that belonged to Lady Duncan. *Manuscripts and Archives Department, UCT.*

Set of miniature postcards and their mailbag container, produced to celebrate the centenary of Rhodes's birth in 1953. *Manuscripts and Archives Department, UCT.*

Leather wallet and calling cards. They belonged to members of the Dowthwaite family from Pinelands, Cape Town. *Manuscripts and Archives Department, UCT.*

Four examples of early 20<sup>th</sup> Century beadwork. Of Nguni origin, and probably associated with Dorothea Bleek. *Manuscripts and Archives Department, UCT.*

Earring my mother wore to a Carnaby Street party in Port Elizabeth in the 60s. *Personal collection.*

My grandmother's broken wristwatch. *Personal collection.*

Very worn bracelet made from human hair. Listed in the finding aid, but lost, so imagined. *Manuscripts and Archives Department, UCT.*

11 moonstones on a string that possibly belonged to Olive Schreiner. *Manuscripts and Archives Department, UCT.*

Illustrated cards from a four-set collection, depicting women's fashions from various eras in the 1800s. *Manuscripts and Archives Department, UCT.*

Teargas canister placed in the archive in the early 1980s, when the police teargassed protesting students on campus. Lost, so imagined. *Manuscripts and Archives Department, UCT.*

Brass lock that belonged to my mother. *Personal collection.*

Broken old South African flag. No provenance. *Manuscripts and Archives Department, UCT.*

ANC badges collected by journalist Colin Legum. *Manuscripts and Archives Department, UCT.*

Brown paper bank bags for copper coins, labeled 5/-, 60d/50c and 50c, placed in the archive to mark the transition to decimal coinage in 1961. *Manuscripts and Archives Department, UCT.*

Passbook of Adelaide Olifant, described in the finding aid as 'crippled'. Lost, so imagined. *Manuscripts and Archives Department, UCT.*







# *SLANTWAYS*

JOANNE BLOCH

# SLANTWAYS

JOANNE BLOCH



MICHAELIS  
GALLERIES



centre for curating the archive 





# Contents

A sensory register – essay by Alexandra Dodd .....	2
Homage to Mr Immelman .....	10
Hoard .....	14
Entanglement .....	20
Musa Askari .....	24
Un-deathmasks .....	26
Troublesome ancestor I: David Livingstone .....	30
Troublesome ancestor II: Cecil John Rhodes .....	32
Translation I: The Queen’s speech .....	34
Translation II: From ‘The New Game of HUMAN LIFE’ ....	36
Translation III: Voyage .....	38
Sense of place I: The scent of longing .....	40
Sense of place II: Karoo .....	41
Finding aid: The archive partially seen .....	42
Notes from a slanty slope – essay by Joanne Bloch .....	44

## ***Hoard, 2013***

Modelling clay, spray paint and silk velvet

Dimensions variable

Detail: Gold sceptre

*Mapungubwe Collection, University of Pretoria*

Photo: Dave Southwood

# A sensory register

Alexandra Dodd

‘The power of readers lies not in their ability to gather information, in their ordering and cataloguing capability, but in their gift to interpret, associate and transform their reading. For the Talmudic schools, as for those of Islam, a scholar can turn religious faith into active power through the craft of reading, since the knowledge acquired through books is a gift from God. According to an early hadith, or Islamic tradition, “one scholar is more powerful against the devil than a thousand worshippers”. For these cultures of the Book, knowledge lies not in the accumulation of texts or information, nor in the object of the book itself, but in the experience rescued from the page and transformed again into experience, in the words reflected both in the outside world and in the reader’s own being.’ Alberto Manguel, *The Library at Night*, 2006<sup>1</sup>

These are the words with which Argentine-born writer, translator and editor Alberto Manguel begins the fourth chapter of *The Library at Night*, his meditation on the meaning of libraries as repositories of knowledge and memory. Like Joanne Bloch, Manguel is a collector. He has spent over a half a century collecting books, and his collection now encompasses around 30 000 volumes, which reside in a library he built from a dilapidated 15<sup>th</sup>-century barn. Manguel’s entrancing treatise on the library feels apposite, bearing in mind

1 Manguel, 91

that the objects being resuscitated here form part of an unusual collection of around 130 artefacts which were set aside around the late 1970s and 1980s as the basis for a museum project that never came to fruition, and which are housed in the Manuscripts and Archives Department of the University of Cape Town Library.

Chapter Four is headed, 'The Library as Power', which seems like an apt entry point to an exhibition that breathes strange new life into what was, until its recent recovery, a fairly dormant collection of largely colonial-era artefacts diligently stashed away in cardboard boxes – largely ignored, possibly even quietly disavowed by the very institution that once saw fit to gather them together for posterity. The ambiguous power of these objects is quite directly brought into question by staging the exhibition, not in the contemporary fine art context of the Michaelis Galleries, but in the more ideologically flexed environment of the Centre for African Studies Gallery – a unit of the university expressly tasked with re-imaging and reconfiguring 'an inherited architecture of knowledge'. ('About: African Studies at the University of Cape Town')

There appears to be little coherence or overarching taxonomical scheme governing the objects in this collection, apart from the fact that many of them might qualify as colonial-era curiosities. But this is not their only oddity. There is another sense, too, in which they are distinctly anomalous articles. They are not books, but they exist among books. They are not texts or recordings in any obvious sense, but their dwelling place – their site of consignment – is a library. This is one of the key riddles that run through the exhibition, bringing us back to Manguel's words concerning knowledge and the active, transformative nature of reading. If knowledge lies not in the book itself, but in 'experience rescued from the page' through the activity of reading, what would be required to unlock experiences encoded into objects? How are we to 'read' the messages and meanings that lie dormant in *things*, rather than

texts, that have been preserved within the sanctity of a library? What is it that objects can tell us about a gone world, and how do they communicate their messages across time? Bloch's exhibition presents us with some eloquent answers to these questions.

By selecting a range of artefacts and paying close attention to the life, history, provenance and backstory of each object, she has brought the unique qualities of that thing into heightened focus. But to leave it there would have left things at the level of texts and textuality – the realm of the historian or researcher. As an artist, Bloch has taken this project quite a few steps further, embracing an object-centred approach to surface other immanent meanings lying latent in the thing. By paying close attention to each artefact's materiality – investing it with her psyche, if you like – the peculiar properties of that thing have risen to the surface.

In each instance, an accent, an atmosphere has provided a cue to be taken forward by the artist through multi-media acts of creative production. In an eerily forensic sense, the spirit or sense of the object comes to dictate the material form of the artwork made after it. So the haunting smell of a wood fire in the Karoo becomes the determining trope to shape an artwork in response to the piece of the cloth in which Olive Schreiner wrapped the completed manuscript of *The Story of an African Farm*. The unfamiliar sense of female command and public authority embodied in the recording of a public address by Queen Elizabeth (later the Queen Mother) during the Royal Visit to Cape Town in 1947 becomes the premise for a sonic artwork that places hypothesis at the foreground of historical interpretation. A speculative spirit emerges from between the SiSwati phrases and faux archival crackles of this piece of aural retrospection. The tone is somehow melancholy and fabulous at once. What world would we be living in now if an African queen had been granted the same degree of institutional reverence and honour as a visiting Anglophone monarch?

By approaching these artefacts in this way and making works that arise out of hints or cues encoded in them, Bloch invites a new orientation to each old thing. As viewers/listeners/receptors, we are invited to attune our personal reactions to what we see/hear/experience, and make connections. Meaning resides neither in the object itself, nor in the eye/ear/hands of the beholder, but is constituted through the experience of connecting to the artefact through the mediating field of the artwork, which activates particular senses and sense memories. As with the experience of reading, which is 'reflected both in the outside world and in the reader's own being' (Manguel, 91), sometimes these associations are private, sometimes they are shared. The artefact itself is not physically in the room; it is only ever a sense of it that is evoked. 'Experience' is 'rescued' from these objects (to use Manguel's words) in a range of different ways. In each instance, the artwork has been crafted in a particular medium to evoke a particular sensory response, so we enter the archive not just through the dominant hegemonic sense of sight, but also through smell, through hearing, through touch.

Far from being a mere conceptual ploy, this entering into and opening out of the archive through the multiplicity of the senses has been an urgent creative response to unforeseen personal constraint for Bloch. In July 2011, six months into her PhD project, she experienced sudden severe sight loss, which forced her to adjust to a whole new way seeing and engaging – not only with the world at large, but also with this chosen archive. Not being able to see clearly has become definitive to Bloch's methodological approach.

Manguel narrates the tale of the writer Jorge Luis Borges, who went blind as a young man while moving through a tunnel on a train reading a detective novel. Shortly after the military coup in 1955 that overthrew the dictatorship of General Péron, Borges was offered the post of director of the National Library. 'Borges thought

it “a wild scheme” to appoint a blind man as librarian, but then recalled that, oddly enough, two of the previous directors have also been blind: José Mármol and Paul Grossac,’ writes Manguel (272). To celebrate his appointment, Borges wrote a poem about “the splendid irony of God” that had simultaneously granted him “books and the night”. (Borges, 113) ‘He worked at the National Library for eighteen years, until his retirement and enjoyed his post so much that he celebrated almost every one of his birthdays there.’ (Manguel, 273)

In addition to the entire exhibition’s enlivening of the alternate senses, there are several works on the show that either directly or obliquely reference Bloch’s impaired sight; from the slightly blurred footage shot during a visit to Rietvlei and Gannahoek, the two Karoo farms on which Schreiner lived while writing *The Story of an African Farm*, to the translation of a phrase from an 18<sup>th</sup>-century puzzle into pompom Braille, to *Finding aid: The archive partially seen*, a body map featuring the various prosthetic tools (sunglasses to reduce hazardous glare, hat to minimise light interference, magnifying glass, iPod for sound recordings etc...) that Bloch has needed to navigate her way through the archive.

In *Finding aid: The archive partially seen*, a map of Bloch’s actual body is directly introduced into the exhibition’s conceptual field of play. The body and the senses are repeatedly foregrounded, reminding us of the centrality of the sensory body in refiguring bodies of knowledge. Here, as in her drag auto-portrait versions of the classic trophy/safari shots of Cecil John Rhodes and David Livingstone, she includes her own body as an unequivocal argument for more implicated ways of knowing – more responsive, intimate modes of engaging with the skeletons in our closets, libraries and museums. In her dragged-up versions of Rhodes, Livingstone and René Ferdinand Malan Immelman – the UCT Chief Librarian, who was the founding curator of this collection – she has been careful to

leave on her rings and/or glasses, deliberately blowing any serious attempt at gender or identity-crossing seamlessness. The effect is a kind of willed semi-drag in which Bloch remains herself even as she plays at adopting the triumphalist macho pomp of Livingstone with his animal horn, the imperialist insouciance of Rhodes lounging about on the golden plains of Africa, or the Calvinist diligence of Immelman, the suited and bespectacled intellectual bureaucrat – a trope of masculinity that seemed to ‘trend’ significantly under Afrikaner nationalism. By stepping into their shoes, Bloch introduces an air of ludicrousness into the routinely reverent depictions of the big men of the archive. By sporting with the masculine identity performances that underlie these photographs, she highlights the inherent campness of the original images.

In its humour and playfulness, Bloch’s work recalls the liberating irreverence of the cross-dressing potter Grayson Perry, whose 2011/12 exhibition, *Tomb of the Unknown Craftsman*, was one of the most popular and critically acclaimed exhibitions ever to be hosted at the British Museum. Perry spent two years behind the scenes at the Museum to curate an installation of new works alongside objects made by craftsmen throughout history from the Museum’s vast collection. ‘Usually exhibitions will be based on academic research of a particular subject, but the British Museum is also a “storehouse of the world’s imagination”. It’s a source of inspiration and has been for many artists,’ writes exhibition project curator Philip Attwood. ‘This exhibition is quite different to anything we’ve done before. It shows how we can think about the world in new ways and reveals the extraordinary imaginative power of the collection.’ (Attwood)

Apart from the shared strategy of creating a new body of work inspired by existing objects in an institutional collection, there are two capital ways in which Bloch and Perry’s work overlap: both artists expressly sport with the toxicity of value and the

performativity of gender. In her 2013 Venice Biennale work, *Hoard*, Bloch interrogates inherited notions of preciousness by modelling glimmering gold simulacra from objects ranging from the ancient to the throw-away, and exhibiting them, like the crown jewels, against regal blue velvet. Some of the objects after which she has refashioned these faux gold artefacts were drawn from this UCT object collection, some are based on priceless pre-colonial artefacts from the Mapungubwe Collection, housed at the University of Pretoria, and others are from her personal archives. This questioning of value is a lifelong obsession for the artist who has devoted herself to establishing a vast collection of cheap, throwaway plastic toys, imbuing them with the cherished status of collectability.

Diamonds also crop up in the form of the bedazzling disco diamanté surface of one of the pieces in the Rhodes 'un-deathmask' series, a sardonic Marxist comeback to Damien Hirst's *For the Love of God* (2007). Bloch's blunt conceptual joke highlights the enduring imperial circuits of global capital that underlie Hirst's hubristic £14-million memento mori, which comprises an 18<sup>th</sup>-century human skull encrusted with 8 601 diamonds. Diamonds and gold are, of course, at the root of Cecil John Rhodes's violent colonial legacy, which, over a century later, still haunts most aspects of life in South Africa, brought into stark relief by events like the Marikana Massacre in 2012, during which 34 striking miners were shot dead by the police.

'Every library conjures up its own dark ghost; every ordering sets up in its wake, a shadow library of absences...' writes Manguel. 'Every library is by definition the result of choice, and necessarily limited in its scope. And every choice excludes another, the choice not made. The act of reading parallels endlessly the act of censorship.' (Manguel, 107) In many senses, the artworks arising out of this library collection serve as postcolonial critiques of the

willed exclusions and partial narratives of the colonial knowledge-making project, with its unconscionable blind spots. But instead of confronting these absences with retrospective indignation, Bloch seems to enter the darkness and feel her way about in it. It is by intuitively examining the cavities and absences in the archive, that she emerges with her subversive, hypothetical, tender and often quite humorous takes on the gross power imbalances of the past.

#### **Works Cited**

'About: African Studies at the University of Cape Town.' *African Studies*. n.d. Web. 31 Jul. 2014.

Attwood, Phillip, 'Grayson Perry at the British Museum?' British Museum Blog, 14 October 2011, Web, 5 August 2014.

Borges, Jorge Luis, 'Poema de los dones', *El hacedor, Obra Poética*, Buenos Aires: Emecé (1977): 113.

Manguel, Alberto. *The Library at Night*. New Haven: Yale University Press, 2006. Print.

# Homage to Mr Immelman



***Homage to Mr Immelman, 2013-2014***

Collage, pen and ink, and photograph

59 x 55cm

(With thanks to Mark Lewis)

Photo: Mike Hall



Between 1940 and 1970, UCT Chief Librarian R.F.M. Immelman devotedly collected and solicited donations of any material he considered likely to be of interest to future generations of scholars. Though his focus was on written material, he also collected objects. In this way, the taxonomy-less object collection to which the works on *Slantways* respond came into being.



Archival fragments  
I, II and III  
Each 22 x 39cm  
Photos: Mike Hall



Photos: Mark Lewis

# Hoard



## ***Hoard, 2013***

Modelling clay, spray paint and silk velvet

Dimensions variable

A selection of objects from the Manuscripts and Archives Department forms the core of this exploration of the issue of value in relation to archival collections. To my remakes of these unloved old things, I added new versions of a few items from the Mapungubwe Collection, housed at the University of Pretoria. Both in terms of the historical evidence of pre-colonial society they provide, as well as in purely monetary terms, these (real gold) artefacts have the undisputed status of priceless national assets. A third selection of objects is drawn from my personal archives. These objects hold meaning and value for nobody but me.

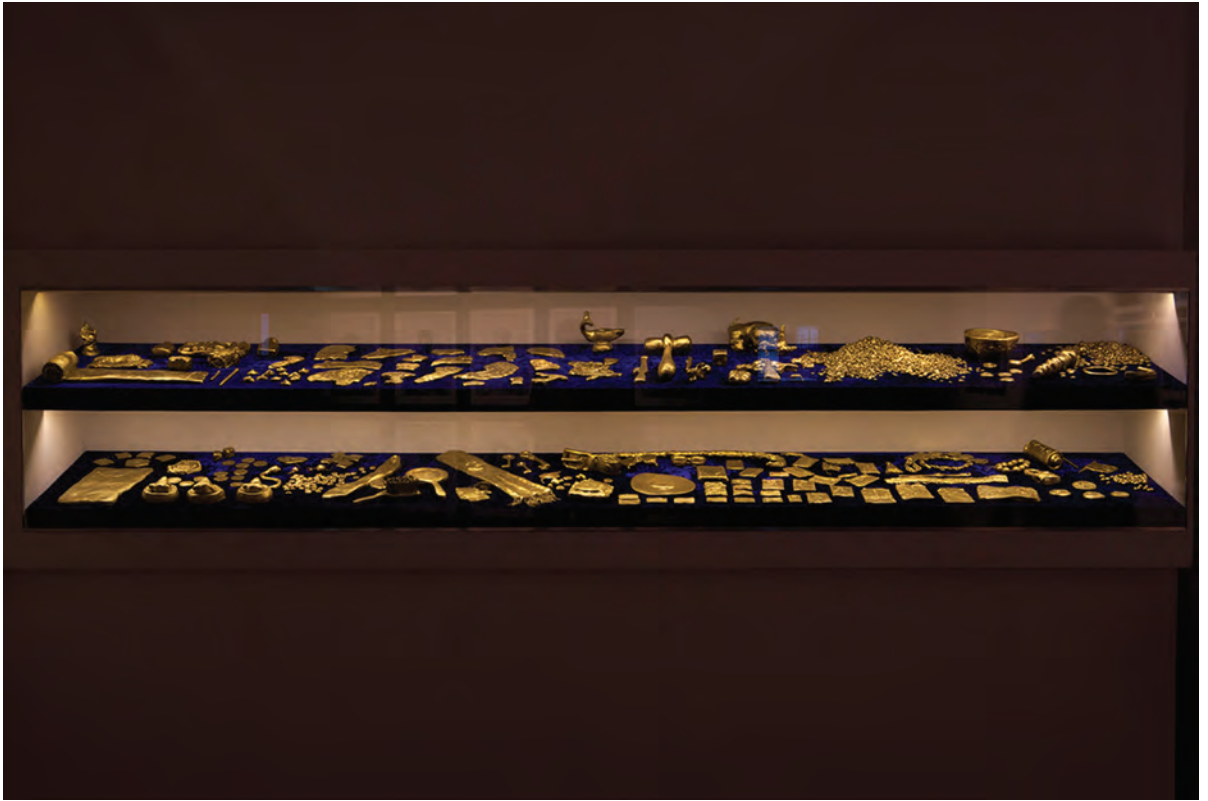

Photos: Courtesy National Arts Festival





Little wooden rifle carved by a South African War prisoner. The words 'Boeren Kamp Ceylon 1901 Mauser' are painted on it in tiny, neat gold letters.  
*Manuscripts and Archives Department, UCT*



My mother's gold bracelet, which she always wore on her upper arm during my childhood.  
*Personal collection*



Hexagon crocheted by my grandmother Susie Heyns, as part of an unfinished blanket.  
*Personal collection*



Leaf from the bodhi tree in Bodh Gaya, India, under which the Buddha became enlightened.  
*Personal collection*



Miniature Bible, written up as 'the smallest printed Bible in the world' and dated 1950.  
*Manuscripts and Archives Department, UCT*



11 moonstones on a string that possibly belonged to Olive Schreiner.  
*Manuscripts and Archives Department, UCT*



Real gold rhinoceros from the Iron Age Kingdom of Mapungubwe, Limpopo.  
*Mapungubwe Collection, University of Pretoria*

Photos: Dave Southwood



Hairbrush that belonged to Ray Alexander.  
*Manuscripts and Archives Department, UCT*



Earring my mother wore to a Carnaby Street party in Port Elizabeth in the 1960s. *Personal collection*



A tiny, blobby plastic baby, which I made rather larger than the original.  
*Personal collection*

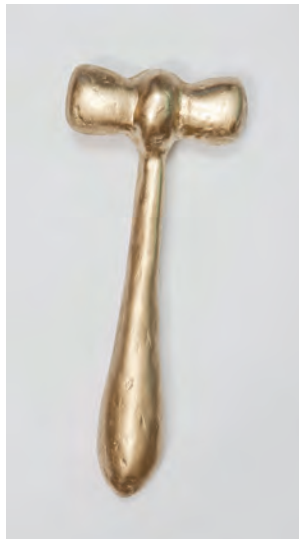

Gavel that belonged to Gideon Brand van Zyl, Governor General of the Union of South Africa from 1945-1950.  
*Manuscripts and Archives Department, UCT*



Early 20th Century beadwork. Of Nguni origin, and probably associated with Dorothea Bleek.  
*Manuscripts and Archives Department, UCT*



Bottles and tray from the first aid kit taken by dentist Walter Floyd on his hunting trip in the then Northern Rhodesia in 1913.  
*Manuscripts and Archives Department, UCT*

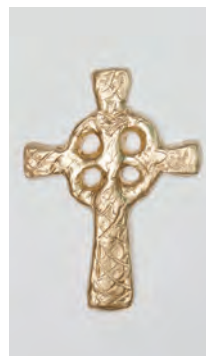

Silver cross. One of several in the archive.  
*Manuscripts and Archives Department, UCT*





A selection of artefacts from the object collection. Manuscripts and Archives Department, UCT Photos: Courtesy Special Collections, UCT Libraries



# Entanglement

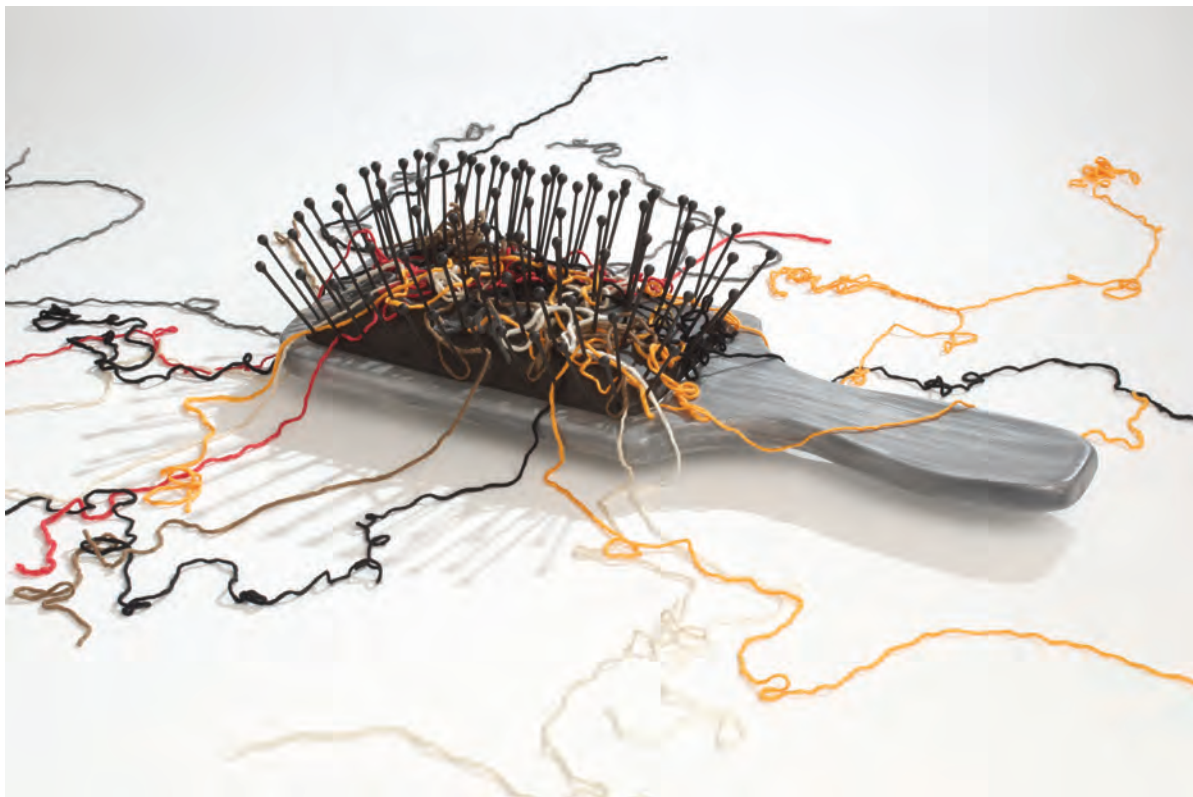

## ***Entanglement, 2014***

High-density foam, wood, modelling clay and wool

140 x 55 x 34cm

(With thanks to Dana Weiner)

Photos: Mike Hall



Hairbrush that belonged to  
trade unionist Ray Alexander.

*Manuscripts and Archives  
Department, UCT*

Photo: Courtesy Special  
Collections, UCT Libraries





Hairbrushes and hand mirror that belonged to Ray Alexander.  
*Manuscripts and Archives Department, UCT*  
Photo: Courtesy Special Collections, UCT Libraries

The hairbrushes of trade unionist Ray Alexander (1913-2004) form part of a collection donated to the Manuscripts and Archives Department by her daughter, Tanya Barben, in 1995. Along with two elaborate decorative brush sets, it is curious to find a very ordinary plastic hairbrush, which, having slipped into the archive, now boasts the status of an object worthy of scholarly attention.

Alexander's daughter, Mary Simons, recalls that the care her mother devoted to her long blonde hair amounted to 'a weekly ritual':

'Each Friday night, she oiled her hair with coconut oil, using a sort of heating device filled with methylated spirits to melt the oil. The following day, she would wash it, adding lemon juice to the final rinsing water. After she had dried it in the sun, my father would brush it... It was a very loving thing.'

# Musa Askari



***Musa Askari, 2014***

Digital print on 100% cotton voile

Photo: Mike Hall



Photo: Courtesy Special Collections, UCT Libraries

Within the collection is a 3cm-long chip of wood. Although it is not listed in the museum objects finding aid, the following explanatory note appears on the front of the envelope in which it has always been kept:

'This chip of wood is from the (wild olive) [scratched out and replaced by] almond tree under which David Livingstone is said to have proposed to Mary Moffat. 1844. Donated by RFM Immelman, who purchased it from the Kimberley Museum.'

Though there is no record of this transaction at the McGregor Museum in Kimberley, in response to my enquiry, an image emerged. Its caption reads 'Musa Askari, who cut down the Livingstone tree, 1899'.

# Un-deathmasks



## *Rhodes un-deathmasks*

I Modelling clay and spray paint, 2013

36 x 22cm

Photos: Mike Hall



III Modelling clay and shoe

polish, 2014

13.5 x 9cm



IV Plasticene, 2014

15 x 9cm



II Modelling clay and diamanté, 2013  
33 x 21cm



Rhodes 'deathmask'.  
*Manuscripts and Archives Department, UCT*  
Photo: Courtesy Special Collections, UCT Libraries



Rhodes deathmask.  
*National Portrait Gallery, London*



Rhodes 'deathmask'.  
*Groote Schuur, Cape Town*  
Photo: Courtesy Groote Schuur  
House Museum

Though a mask-like representation of Rhodes's face has been understood to be his deathmask since its donation to the archive as part of the Sibbert Collection in the 1960s, a close inspection reveals that it is entirely different from the official deathmasks held in the Harare Museum, in Zimbabwe, and the National Portrait Gallery, in London. Interestingly, some masks, supposed to be Rhodes's deathmasks, but which turn out to be nothing of the sort, are also to be found at the Cape Town Club and at Groote Schuur House Museum, his official residence.

# Troublesome ancestor I: David Livingstone





Photos: Mark Lewis

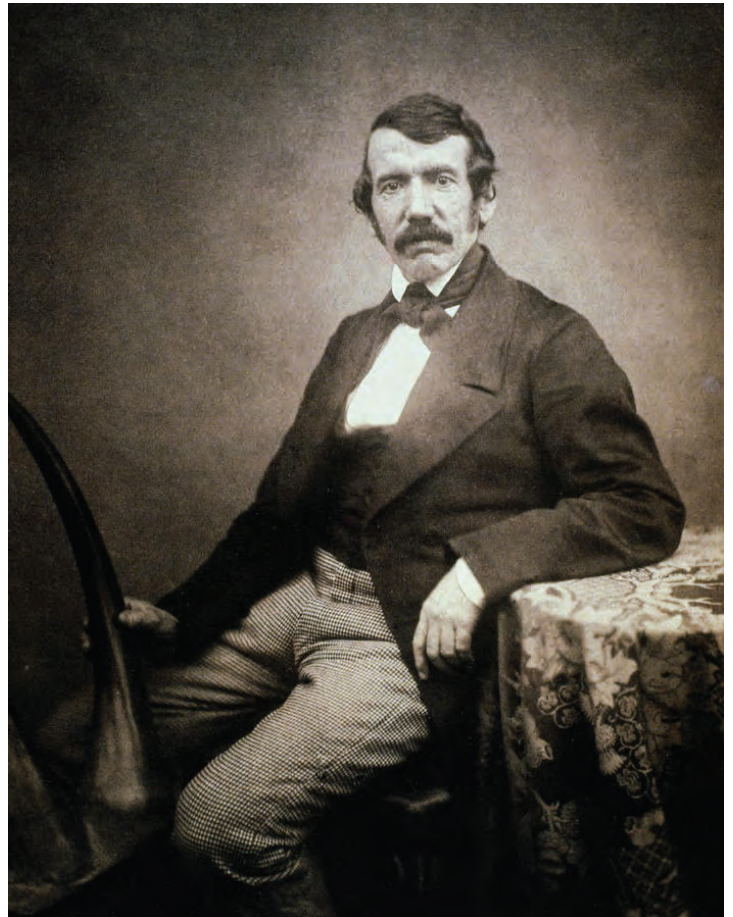

Opposite left:  
***Troublesome ancestor I:***  
***David Livingstone,***  
**2013-2014**  
Collage, pen and ink, and  
photograph  
57 x 45cm  
(With thanks to Mark Lewis)  
Photo: Mike Hall

# Troublesome ancestor II: Cecil John Rhodes



***Troublesome ancestor II: Cecil John Rhodes, 2013-2014***

Collage, pen and ink, and photograph

44 x 64cm

(With thanks to Mark Lewis)

Photo: Mike Hall



Photos: Mark Lewis

# Translation I: The Queen's speech

## ***Translation I: The Queen's speech, 2014***

Audio

Duration: 6 minutes, 16 seconds

(With thanks to Manesi Kekana and James Webb)



Pen used by Queen Elizabeth when she signed the visitor's book in the UCT library in 1947. *Manuscripts and Archives Department, UCT*  
Photos: Courtesy Special Collections, UCT Libraries



Record of the speech made by Queen Elizabeth when she received her honorary PhD from UCT in 1947. *Manuscripts and Archives Department, UCT*

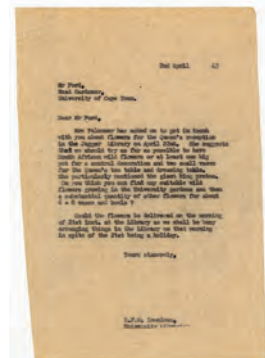
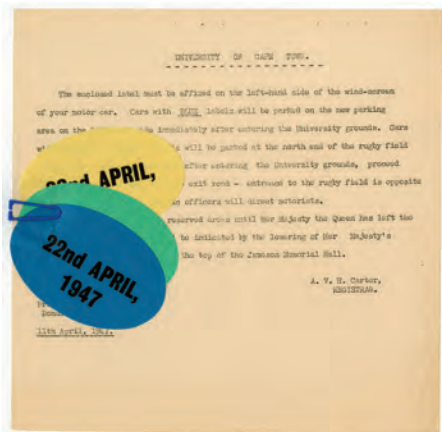
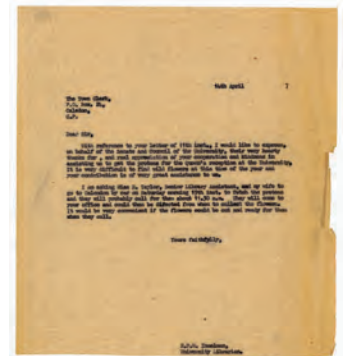
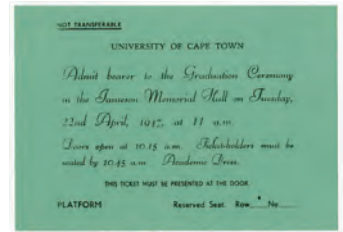

Archival fragments relating to the Queen's visit to UCT in 1947. Manuscripts and Archives Department, UCT

During the Royal Tour of South Africa in 1947, the Queen of England was presented with an honorary PhD in Law by the University of Cape Town. After the graduation ceremony in Jameson Hall, the Queen signed the visitor's book in the library with a gold-capped fountain pen, which, together with the record of her graduation speech, forms part of the archival object collection.

In the interests of imagining an alternative history, this work presents the Queen's speech translated into and performed in SiSwati.

# Translation II: From 'The New Game of HUMAN LIFE'



***Translation II: From 'The New Game of HUMAN LIFE', 2014***

Pompoms and pins

Dimensions variable

(With thanks to Erica de Greef)

Photos: Mike Hall





Braille translation of 'The Troublesome Companion'.



Pieces from 'The New Game of HUMAN LIFE'.  
Manuscripts and Archives Department, UCT  
Photos: Courtesy Special Collections, UCT Libraries

The 18th-century puzzle, 'The New Game of HUMAN LIFE', entered the archive as part of a collection donated by Rev R. Jeffcoat between 1950 and 1972. The game consists of a puzzle made up of a series of masculine human types, ranging from 'The Lover', to 'The Hypochondriac', to 'The Silent Man'.

In *Translation II*, the textual description of my favourite of these puzzle pieces, 'The Troublesome Companion', has been rendered into an enlarged Braille version.

# Translation III: Voyage



## ***Translation III: Voyage, 2014***

Wire microscope, metal sailing ship,  
motors and mechanisms, 100%  
viscose cloth and halogen light

Dimensions variable

(With thanks to Brian Hove, Richard  
Kilpert and Andrew Juries)



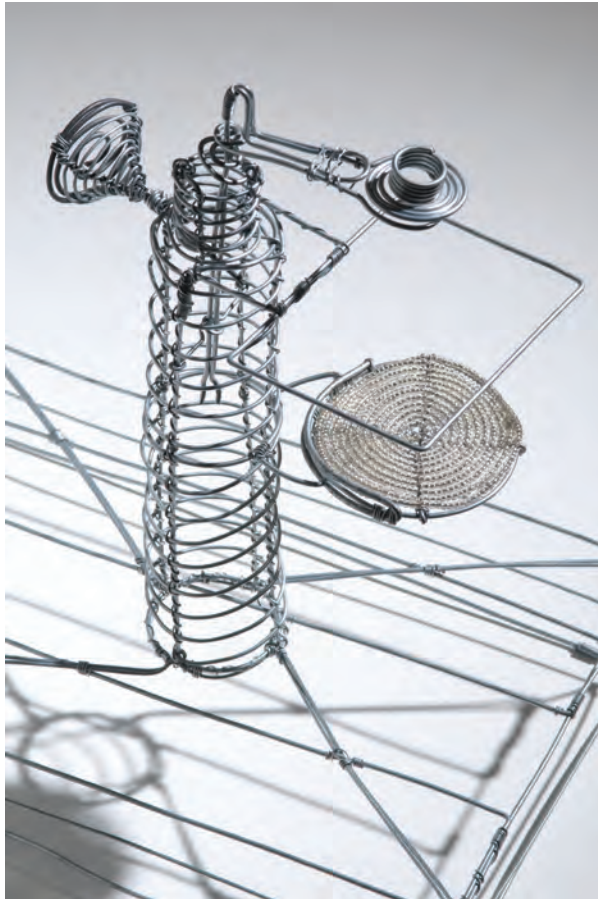

Photo: Mike Hall



Photo: Courtesy Special Collections, UCT Libraries

A small brass microscope that screws into the lid of the wooden box in which it is contained was donated to the archive as part of the Jeffcoat Collection. It was used by F.G. Percy as one of Charles Darwin's shipmates on the exploratory voyage of the Beagle (1831-1836). This work presents the moving shadows of wire and metal interpretations of both the microscope and the ship.

# Sense of place I: The scent of longing

## *Sense of place I: The scent of longing, 2014*

Cotton calico cloth and woodsmoke

Dimensions variable

(With thanks to Erica de Greef)

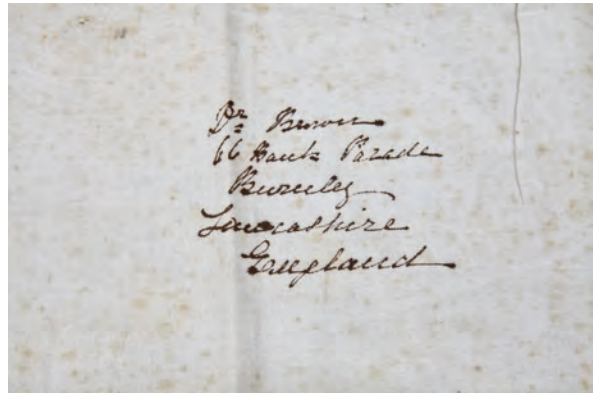

Photos: Courtesy Special Collections, UCT Libraries

In late 1879 or early 1880, Olive Schreiner sent the manuscript of *The Story of an African Farm*, wrapped in a piece of plain white calico, to her friends, the Browns, who were living in Lancashire, to find an English publisher. This piece of cloth, addressed to Dr John Brown in Schreiner's hand, was donated to the Manuscripts and Archives Department in 1960 by Miss Nancy Dick in memory of her mother, Mrs R.E. Dick, who was the Brown's daughter.

According to Mary Brown's memoir, when she unwrapped the manuscript and held the cloth up to her face, she was overwhelmed by a nostalgic longing for the Karoo brought on by the scent of wood smoke that permeated it.

To re-invoke this sensory experience, two pieces of cloth have been smoked over burning branches of the Acacia Karroo tree, also known as 'soetdoring'. This tree is endemic to the Karoo, as well as to many other parts of Southern Africa.

# Sense of place II: Karoo



## ***Sense of place II: Karoo, 2014***

Duration: 3 minutes,

6 seconds

(With thanks to Andrew Juries)

This video work takes the form of a visual cameo of a visit to Rietvlei and Gannahoek, two of the farms in the Cradock district on which Olive Schreiner lived while she was writing *The Story of an African Farm*.

As a means of representing my personal visual experience, scenes shot ‘the way the camera sees’ – ie. conventionally – have been alternated with scenes shot using a filter that produces a more hazy image.

# Finding aid: The archive partially seen

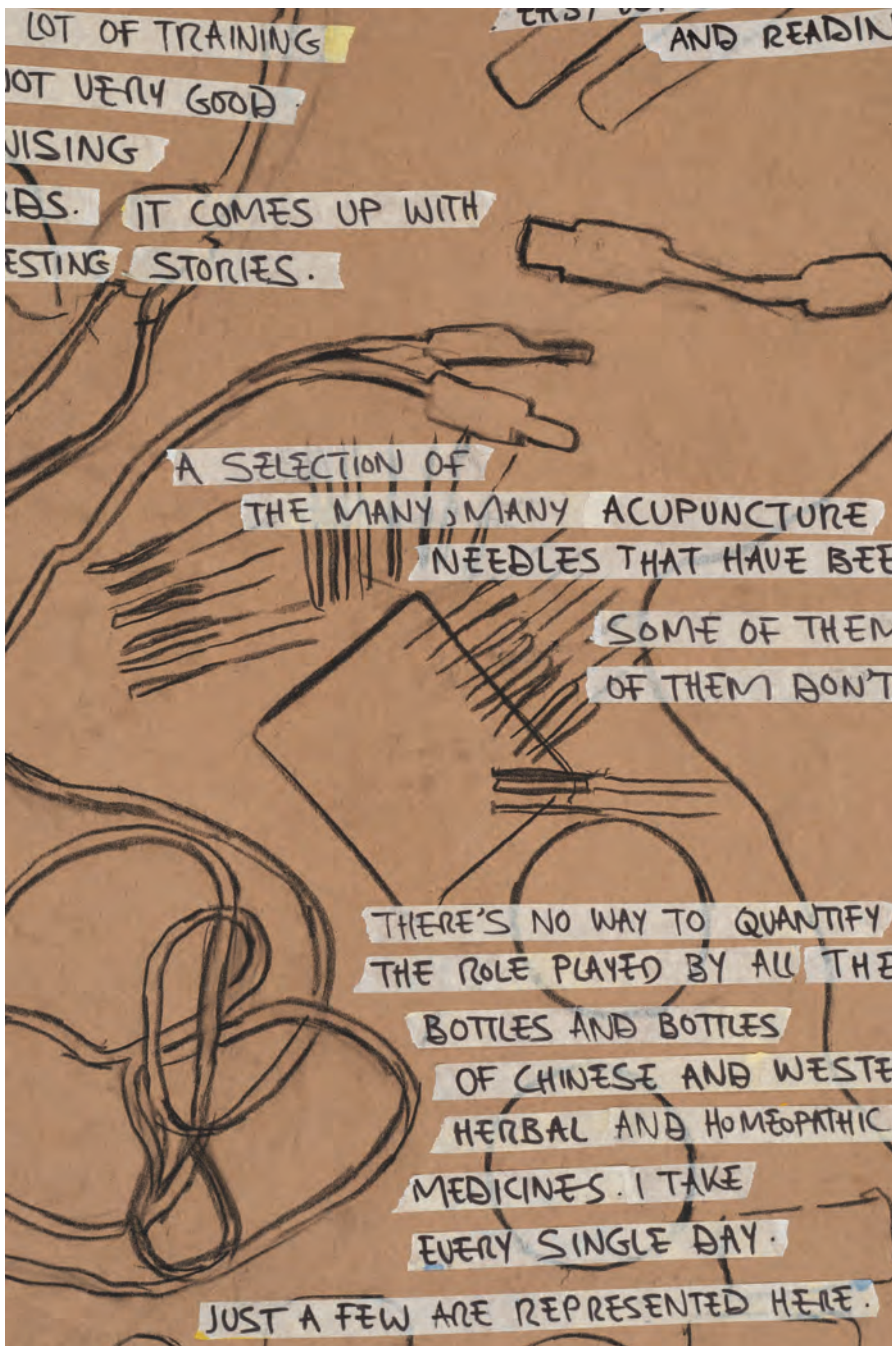

***Finding aid: The archive partially seen, 2014***

Graphite, pen, masking tape and cardboard

224 x 88cm

Photos: Mike Hall

In July 2011, six months into my PhD project, I experienced sudden severe sight loss, as a result of which I have been forced to adjust to a new way of seeing, and fundamentally alter my approach to both researching and engaging with the archive.

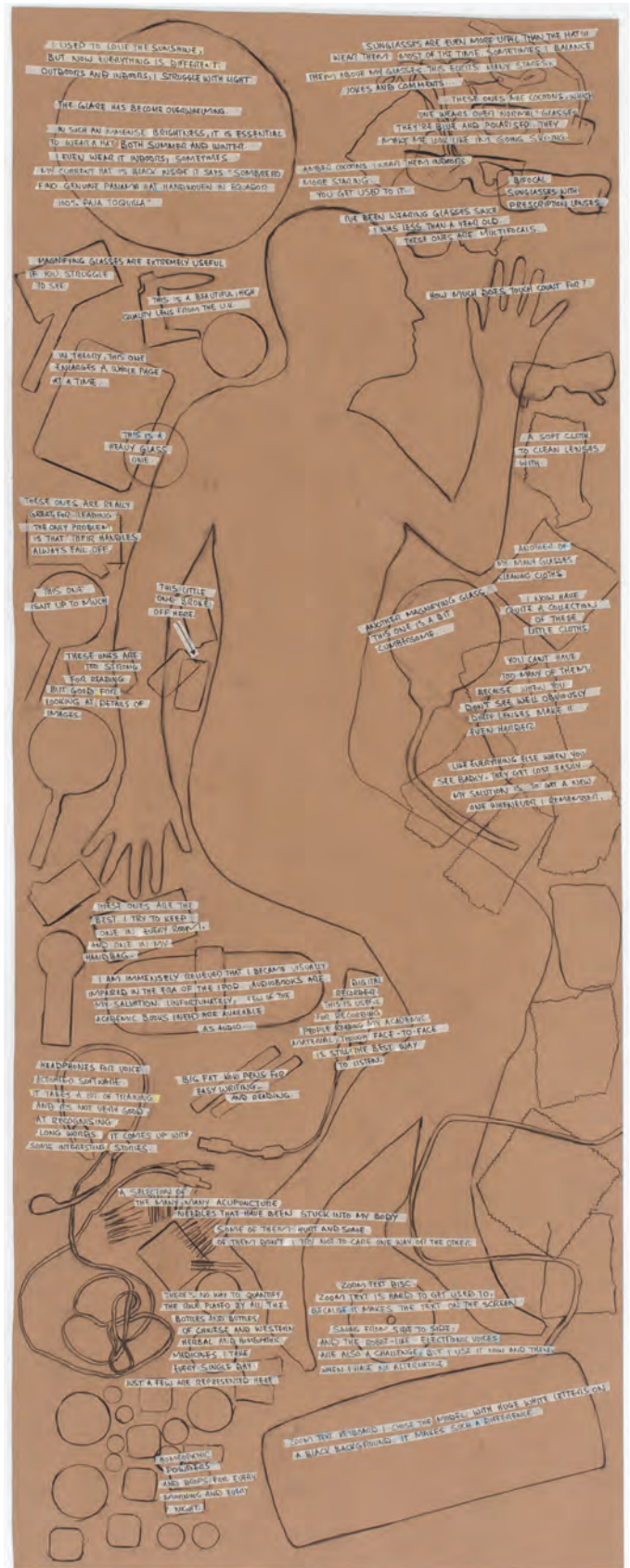

# Notes from a slanty slope

Joanne Bloch

## Entering the archive

I began my work with the Manuscripts and Archives Department object collection in a state of confusion and doubt. This wasn't caused by my (considerable) academic rustiness, or even by my 30-year long absence from UCT upper campus, which made my daily experience feel slightly surreal. Rather, I was uncomfortable because I, an artist-collector, had somehow bluffed my way into an archive, where I did not understand the rules.

My initial impressions did nothing to reassure me. Bemused, I tried to be methodical as I examined the quirky collection I had come to investigate – four or five cardboard boxes containing a variety of objects, most of them assembled by UCT Chief Librarian R.F.M. Immelman from about 1940 until his retirement in 1970.

The collection turned out to be an entirely random mixture of objects: a gold-topped fountain pen, a silver inkstand, a worn piece of embroidery, an inscribed gavel, a miniature microscope, several extremely fragile wax seals, a chess set and other obscure and ancient games, battered old tins containing university medals and badges, a pink silk tie, an unlabelled box full of African beadwork, a chip of wood and many others.

On the one hand, as befitted a lover of things old, wonky and strange, these artefacts fascinated me. At the same time, though, I was slightly repulsed by them – they seemed too aged, too bedraggled, too polluted by the colonial past to which they bore witness, or would have if anybody knew of

their existence. To make matters worse, I experienced a strong feeling of antipathy towards the archival setting itself. I disliked its smell and the hum of the air conditioning, hated the colour and texture of its carpets, and felt a strong aversion to the gloomy, chill, slightly sinister stack room behind the reading room, with its claustrophobic rows of grey metal mobile shelving, between which I felt one might easily be pressed like a flower in a book. Because I experienced the archive as overwhelming and oppressive, at first I found it impossible to stay there for long – after half an hour of slowly unpacking one of the cardboard boxes and staring nonplussed at one peculiar, usually context-less artefact after another, I would start longing for the world outside, make excuses to myself and hastily depart.

I began to feel differently about the archive when I realized that, quite apart from the slightly sad, marooned object collection, there were also any number of genuinely fascinating, often anomalous objects lurking in its depths, and that nobody, not even Lesley Hart, who had worked in the department for 14 years, knew about all of them. This confused me utterly – I found it difficult to comprehend that so many things could be consigned in this way to the dead space of the archive, kept so wholly removed from the humans who might use them, touch them, or simply look at them. How was I to understand this strange state of affairs? More than that, how did it challenge me as an artist? How was I to re-imagine my practice so as to produce artworks that allowed these objects to make sense, to speak for themselves in a way that would resonate with a contemporary audience?

Gradually it occurred to me that, though on the face of it the ‘raw material’ of the proposed project was very different to what I was used to working with, two elements that had always had a central place in my work were still present, albeit in a different guise: collecting and the world of things.



## My career as a collector

For me, collecting had begun in my childhood. Though I was fickle enough to ramble, on occasion, down various enticing collecting byways, my primary focus was on postcards. I clearly remember the honourable founding members of that first collection: a Spanish dancer with embroidered hair and real lace on her red dress, and the googly-eyed 1960s-style child, on the back of which I wrote my name in huge, wobbly letters. Then, there is the card that shows a bright, collaged cityscape. 'Dear Joko,' it reads, in writing carefully adapted to suit the beginner reader, 'I hope you like this pretty card.' I did. In fact I loved it, and I loved it more thoroughly and for far longer than its sender, my mother, could ever have imagined.

This was the beginning, but my magpie tendencies revealed themselves more fully when I was eight or nine. Was I encouraged

to collect? I suspect that rather, some lurking instinct to accumulate, to order and to treasure kicked in spontaneously. I remember that from the start I was prone to the avarice that marks the true collector, and was not particularly selective – all contributions were welcomed with equal delight. In this regard, was I perhaps like Immelman, who solicited donations for his collections, including objects, from far and wide?

I pored for hours over my postcards. As far as I was concerned, their origin was unimportant. What mattered was that they had joined my collection – another attitude characteristic of the serious collector. (Benjamin, 204) Gerald Quinn, the first archivist in the Manuscripts and Archives Department, recalled that this attitude was also similar to that of the early custodians of the object collection, who focused more on gathering and caring for the material than on its provenance.<sup>1</sup>

Collectors do have various tendencies and attributes in common – both Immelman and I clearly loved the hunt, for instance, whose ‘gratification admit[s] of no compromise or exception.’<sup>2</sup> However, I believe that there are always idiosyncratic reasons for attachment to a particular collection. For me, postcards served to reveal the world and hint at my own future as a part of it. Since the images they bore were photographs, they seemed to be respectable evidence that these mysterious places, these inconceivably rich and beautiful vistas were really out there. They *existed*; and if my Uncle Basil’s illegible, spiky handwriting on the back of an aerial view of Piccadilly Circus proved that he had immersed himself in its miraculously complex geometry, then so would I, when I grew up. (At this stage, it hadn’t yet occurred to me that postcards’

1 Interview 7 April 2012

2 Nabokov, V, 1951: 126 This is part of an extended description of Nabokov’s lifelong obsession with butterfly collecting.

representations of places might not be as innocent as they seemed. This revelation had to wait for the 3D cards I collected in the early 80s, whose grotesquely deceitful representation of South African life were so violently at odds with the realities of the day that they were loaded with an irresistible irony.)

Many other qualities of my postcard collection fascinated me. I liked the way they made up a set of things that were alike but not alike, each one speaking at the same time of many things: itself, the place it showed me, the person who had written on it as well as of all the other cards in the pile. My enjoyment of their potentially sequential quality, as well as the fact that they could be ordered in innumerable ways hinted at my future compulsion to develop taxonomies. Of course, these aspects of my collection are also aspects of all collections, and I worked with them more consciously in the pinboard work I produced for my MA exhibition in Johannesburg in 2004, *Thingerotomy*.

As a postcard collector, I was a generalist, as likely to buy a garish card bearing the image of a bower in Naples as one showing a bare-breasted Kenyan woman, dancing cut out against an impossibly azure sky. This quality I also shared with Immelman, who welcomed vastly different artefacts into the elastic embrace of his object collection... perhaps he too enjoyed the breadth of possibilities that such a range of things spoke of.

One particular subset of another favourite childhood collection, my beads, illustrates an additional idiosyncratic focus that persisted into my adult collecting and art making process.

Each of these beads was made of a small opaque plastic oval, with two delicate, curved claws on either side ending in full stop-like bobbles. The idea was to link the claws to form a chain. Over time, though, a few claws had broken off, leaving several beads with three limbs instead of four. My friend and I called these unfortunates 'the cousins'.



***Joanne's kitchen: wall of food, 2004***

Found objects, pins,  
wall clock and fridge  
magnet letters  
115 x 220cm



***Epiphany, 2004***

Found objects, pins and  
rope lighting  
158 x 135cm

I was concerned about the cousins. Their lot was cruel, I felt, and they needed somehow to be incorporated. We solved the dilemma by teaming the cousins up with one another every time we linked their able-bodied companions into a chain. This allowed us to feel that even if they couldn't participate fully, some social interaction was still available to them.

A feeling for the damaged and the aged remained with me over all my years of collecting. Amongst my collections, I still have a shoebox containing a selection of broken things imagined as the basis of an artwork celebrating imperfection... And certainly, together with its eccentricity, the shabbiness of the Manuscripts and Archives object collection, its air of lonely abandonment, was one of the features that most recommended it to me. Like the cousins, these artefacts seemed to be begging for some kind of salvage operation, though the taint of colonialism they will always bear has called for a rather more complex, multi-dimensional and speculative response.

## The world of things

In 1988, I suddenly found myself catapulted into life in exile in North London. Survival was now the priority, and all collecting had, of necessity, to be savagely curtailed.

Though the tantalizing riches of the London markets made this a painful moment, it was also instructive, because I was impelled to recognize the pleasure of looking at things without necessarily needing to buy them. At Nag's Head and Ladbroke Grove markets, and especially at Brick Lane, where I wandered almost every Sunday for three years, I was initiated into a life-affirming weekly worship in the Church of the Holy Rubbish.

In those days, Brick Lane was utterly filthy. Part of the market was literally a series of rubbish heaps. Piles of yellowing, crumpled



***The people, 2007-2014***

Found objects

Dimensions variable

paper, bits of broken machinery and things impossible to recognise were mingled randomly within a maze of decaying lanes and yards, demarcated by sections of rotting fence and brickwork so old that it was black.

This part of the market was the domain of traders straight out of Dickens – haggard, red-nosed old men, dressed in dark, tattered clothing, who hawked and spat. The poverty of their goods was troubling: typically they would preside over a sad selection of rusty screws, misshapen shoes and chipped crockery sold straight off the grimy pavements. It was hard to imagine anyone wanting or needing to buy any of this, but the stallholders' dedication underlined the significance of display. These old men set out their threadbare wares with utter aplomb, as though they were employed on the shop floor at Harrods.

In the centre of the market, meaty young Londoners, wearing nothing more than a T-shirt and jeans in the iciest winter weather, and puffy white trainers all year round, sold an array of cheap kitchen cleaners, miracle vegetable peelers, hardware and workaday clothing... but after only a glance, I passed them all by. I was heading for the second hand furniture, trays of broken jewellery and obscure metal badges, tangled piles of musty vintage clothing and general miscellaneous junk further down the market. I seldom bought, but I feasted my eyes.

I remained faithful to this practice, consisting simply of looking, and sometimes of touching, at various favourite markets in each of the cities I lived in for the next 20 odd years. I looked out of curiosity, and out of sheer awe at the endless waves of things, both old and new, washing through the world, carrying multiple intriguingly unknowable stories with them.

As time went on and my circumstances eased, this form of looking was overlaid by another sort – the slightly shifty, calculating gaze of the collector trying not to betray any excitement. I began to collect small trashy things in earnest in the mid 1990s – tiny toys, pompoms, fridge magnets, tatty bits and pieces from lucky packets and egg machines and Christmas crackers. In 1995, inspired by a friend's design for a jewellery board, I started to display my collections as pinboards. My twin delights had finally coalesced, to produce a symbiotic art practice – persistent and faithful daily collecting, coupled with the production of art works based on my greedily hoarded pickings.

At first, both collecting and the making process unfolded slowly – I remember, for instance, taking months to collect about 40 skinny plastic creatures that could be manipulated so that they moved up and down thin transparent tubes containing tiny yellow and shocking pink sweeties. Soon, though, collecting gathered its own, obsessive momentum. I was on a quirky roll,

with some surprising consequences. When I lived in Troyville in 1999, I became known to neighbourhood children, amongst whom I would share the sweetie by-products of my lucky packet buying sprees. At the time, I was also collecting toy watches. In the afternoons after school, little gangs of children would hammer on my door, shrieking ‘Auntie! Auntie!’ in shrill, persistent voices... This happened so often that I sometimes pretended to be out – but when I relented, I was always confronted with the same request; ‘Auntie! Give us watches!’

As a South African who had attended university in the early 1980s, I could not be unaware of the contradictions of my own position in relation to all of this; as a consumer obsessed with tacky bits and bobs from the rubbish end of the thing world, I was complicit in the perpetuation of the incessant process of production and consumption, the ongoing pumping out of the awful surfeit of trashy stuff, the riches manufactured for the multitudes too poor to afford real treasure. In time, this contradiction wormed its way to the heart of my art making process, and I was forced into an ongoing engagement with a range of complex issues relating to value and how to decipher it. A version of this, focus, relating specifically to issues of value in the archive, has re-appeared in *Hoard*, the centrepiece of *Slantways*.

## Sight loss

With no warning, midway through the first year of my PhD, I was faced with severe, irreversible sight loss.

Like all extreme losses, sight loss ruthlessly tears away many certainties. Suddenly, an invisible tide had turned, and my old process of collecting, which for years had been my sustaining enthusiasm, had abruptly become impossibly difficult. For me, Walter Benjamin’s distinction between the optical character of the

flaneur and the tactile nature of the collector had never held true – all the love was in the seeing. (Benjamin, 206) With the restricted visual field, worsening cloudiness and exhausting, exaggerated white-out glare that characterizes my new version of sight, my beloved markets had suddenly become a private torture.

In such circumstances, there are no painless choices. My first inclination was to adopt an extreme measure: an ascetic turning away from these things – representatives of the material and the worldly, in recognition of their (and my own) sad but inevitable impermanence. As time has passed, though, the realisation that visual impairment is not an all-or-nothing affair has allowed me to think differently. Instead of the solid darkness we think of as ‘not seeing’ or blindness, along with many other visually impaired people, I now inhabit a strangely in-between ocular space. In recognition of the potentialities of this condition, I have come to think that the pleasures of collecting may not yet entirely have died. In this spirit, I recently found my first second hand record at a local monthly market... May many others follow!

The onset of impairment has also forced me fundamentally to rethink my art making practice, which since 2011 has been focussed almost entirely on my PhD. The inclusion of some form of collecting process as a response to the collection I was researching was clearly no longer viable. Some time had to pass before I could fully envisage a set of new approaches that felt appropriate, but the work that ultimately ensued has added a new dimension to my practice.

Again as an acknowledgement of the liminal quality of my impaired sight, I have chosen to pursue approaches that, both in their making and for their response, focus on the relatively less celebrated senses of hearing, smell and touch. These works also draw heavily on the felt particulars of my own embodiment. I should emphasise that my intention is not entirely to abandon the

world of visuality, or even the land of things. Rather, in *Slantways* I have tried to augment my limited ability to produce work relying exclusively on sight with the incorporation of a multi-sensorial approach, as well as to integrate my impairment as one of the work's defining features.

**Works cited**

Benjamin, Walter. *The Arcades Project*. Cambridge, Massachusetts and London, England. Belknap Press. 2009

Nabokov, Vladimir. *Speak, Memory: A memoir*. London. Gollancz. 1951.

# Acknowledgements

My heartfelt thanks to my supervisors, Pippa Skotnes and Carolyn Hamilton, as well as to Penny Siopis for her invaluable input.

I am indebted to many collaborators and helpers, including Lucia Banda, Laurel Bloch, Diana Cilliers, Erica de Greef, Veronika de Greef, Chris Emery, Wendel Fernandes, Brian Hove, Georgia Humphrey, Verna Jooste, Andrew Juries, Manesi Kekana, Richard Kilpert, Vekhe Kruger, Mark Lewis, Brenton Maart, George Tobias, Hedley Twidle, James Webb and Dana Weiner.

I would like to thank Tanya Barben, Lesley Hart, Clive Kirkwood, Renate Meyer, Isaac Ntabankulu and Paul Weinberg for their support in the archive, and Vida Allen, Rayda Becker, Nomusa Makhubu, Mary Simons and Paul Walters for their help with additional research and useful insights.

Thanks are also due to Vaun Cornell, Mandy Darling, Alex Dodd and Mike Hall for the work they put into my catalogue, and to Bridget Simons, Carine Zaayman, Mymoena Shaik and Amaal Davids for their administrative assistance.

Thank you to the Centre for African Studies for providing me with the venue for my exhibition, and to Lilian Jacobs and Meghna Singh for their logistical support.

Finally, my grateful thanks to the National Lottery Distribution Trust Fund, who have funded the Fieldworks project of which this exhibition is a part, the Archive and Public Culture Research Initiative and the Michaelis Gallery for their generous financial support.

This exhibition forms part of my PhD in Fine Art. It was made to accompany the exhibition, *Slantways*, shown at the Centre for African Studies Gallery, Harry Oppenheimer Institute Building, University of Cape Town, from 11-25 September 2014.

A selection of artefacts from the Manuscripts and Archives Department object collection was concurrently displayed in the Special Collections reading room, Jagger Library.

No part of this publication may be reproduced in any form without permission from the artist.

Joanne Bloch: [joanne@lando.co.za](mailto:joanne@lando.co.za)

Design: Mandy Darling

Printing: Hansa Print

61.



*The troublesome Companion.*

FUNDED BY

