

THE INFLUENCE OF STEEL MICROSTRUCTURE ON ABRASIVE WEAR IN SOILS

O. SCHEFFLER

A THESIS SUBMITTED TO THE
FACULTY OF ENGINEERING,
UNIVERSITY OF CAPE TOWN, IN
FULFILMENT OF THE
REQUIREMENTS FOR THE DEGREE
OF MASTER OF SCIENCE.

DEPARTMENT OF MATERIALS ENGINEERING
UNIVERSITY OF CAPE TOWN

APRIL 1987

The copyright of this thesis vests in the author. No quotation from it or information derived from it is to be published without full acknowledgement of the source. The thesis is to be used for private study or non-commercial research purposes only.

Published by the University of Cape Town (UCT) in terms of the non-exclusive license granted to UCT by the author.

ACKNOWLEDGEMENTS

I would like to express my sincere gratitude to the following people who assisted me in producing this thesis.

Professor C. Allen and Professor A. Ball of the University of Cape Town for their supervision, guidance and advice.

Mr. W. Roux of Andrag & Sons, and Mr. F. Venter, formerly of USCO, for supplying the materials.

Mr. W. Hall of the S. A. Department of Agricultural Engineering (Stellenbosch) for arranging suitable test fields.

Mr. Parker, Mr. Swart, Mr. Grobbelar and Mr. Van Zyl for the provision of test fields and equipment.

Dr. N. Comins for arranging the use of facilities at the Council for Scientific and Industrial Research (CSIR).

Dr. M.A. Moore and Dr. J. Cooper for their discussions and encouragement.

Mr. N. Dreeze, Mr. A. Rapley and Mrs. H. Bohm for their technical assistance.

Mr. B. Greeves for his photographic work.

Mrs. S. Betz for her assistance in the field tests and in the preparation of this manuscript.

Miss L. Hankey and fellow students for their support and encouragement.

Finally, the CSIR for financial support for the duration of this project.

ABSTRACT

A hypoeutectoid steel has been heat treated to produce a range of different hardnesses and microstructures. A simulative field test rig has been employed to determine the relationship between microstructural parameters, material properties and soil constitution. Attempts have been made to correlate the ranking order for the wear resistance of similar treated steels in field and laboratory tests.

It has been established that wear resistance is a function of soil constitution, steel carbide morphology and hardness. Explanations have been advanced for the differences in the wear resistance of similar steels in different soils based on the mechanism of material removal. Recommendations have been made regarding the selection of steel microstructure for varying soil conditions.

CONTENTS

ACKNOWLEDGEMENTS	(i)
ABSTRACT	(ii)
<u>1: INTRODUCTION</u>	1
AIMS AND OBJECTIVES	1
<u>2. LITERATURE SURVEY</u>	3
ABRASIVE WEAR	3
DEFINITIONS	4
CLASSIFICATIONS	5
MODELS	7
WEAR MECHANISMS	11
Basic mechanisms of abrasive wear	11
PROPERTIES OF THE ABRASIVE	13
Abrasive type and relative hardness	13
Particle size and shape	15
PROPERTIES OF THE WEARING MATERIAL	17
VARIABLES IN THE WEAR ENVIRONMENT	22
Load	22
Sliding velocity	23
Humidity	24
Wear path length and specimen size	24
WEAR OF TILLAGE TOOLS	26
TOOL TYPE, DESIGN AND FORCES ACTING	26
SOIL GEOLOGY AND MOISTURE CONTENT	30
MATERIALS FOR GROUND ENGAGING PARTS	35
WHITE LAYERS	39
APPEARANCE	39
STRUCTURE	40
FORMATION MECHANISMS	42
WEAR TESTING	45

<u>3. INITIAL STUDIES</u>	50
INTRODUCTION	50
MATERIALS AND HEAT TREATMENT	51
SIMULATIVE FIELD TEST RIG	52
Testing procedure	54
LABORATORY TESTS	55
Abrasion test	56
Rubbing test	56
CONCLUSIONS FROM THE INITIAL STUDIES	57
Assessment of material	57
Assessment of simulative field test	58
Assessment of laboratory tests	58
<u>4. MAIN EXPERIMENTAL WORK</u>	59
MATERIALS	59
SPECIMEN PREPARATION	59
HEAT TREATMENT	59
OPTICAL METALLOGRAPHY	62
MECHANICAL PROPERTIES	63
FIELD TESTS	65
Stoney soil	66
Sandy soil	66
Clayey soil	67
LABORATORY TESTS	67
Belt linisher test	67
Dry sand/rubber wheel test	67
ABRASIVE PARTICLE EXAMINATION	75
SURFACE STUDIES	76
Dry sand/rubber wheel abrasion test specimens	77
Belt linisher test specimens	78
Field test specimens	79
Microhardness tests	81
White layers	83

<u>5. DISCUSSION</u>	85
INTRODUCTION	85
MICROSTRUCTURES	85
FIELD TESTS	87
DATA TRANSFERABILITY BETWEEN FIELD AND LAB TESTS	90
WHITE LAYERS	91
<u>6. CONCLUSIONS</u>	93
<u>7. FURTHER WORK</u>	95
REFERENCES	96
APPENDIX	104

CHAPTER 1

INTRODUCTION

The rapid wear and failure of ground engaging tools constitutes a major problem to agriculture in South Africa. In addition, the time lost while replacing worn parts can also be expensive, bearing in mind the often limited periods in which ploughing and tillage can be carried out.

Little quantitative information is available on the factors affecting tool wear for the different soil conditions experienced in South Africa. In view of this lack of knowledge, a cooperative programme of work was instigated between the CSIR and the South African Department of Agriculture on the abrasive wear performance of tillage tools when subjected to different soil conditions. Initially the programme was aimed at the development of a suitable field test, which would both simulate the conditions experienced by tillage tools and differentiate between materials. It was also decided to assess the viability of laboratory tests to circumvent lengthy and expensive field trials.

This work is part of the ongoing process to reach an understanding of the factors of importance in the abrasive wear of materials by soil, as only then can suitable solutions be formulated to minimize the cost and inconvenience of replacing tools in the agricultural industry.

AIMS AND OBJECTIVES

The fundamental aim of this programme is to understand the mechanisms of wear responsible for the deterioration of ground engaging tools in South African soils. Such an understanding will make it possible for sound advice to be given to the agricultural industry concerning the correct selection and heat treatment of materials for a particular soil location. At the present time, this appears to be

carried out in a non-scientific manner, and opportunities therefore exist for significant savings of resources by introducing measures to minimize wear through controlled scientific study.

The specific aims of the work reported here were the following:

a) To select and heat treat a suitable carbon steel to produce a range of microstructures.

b) To evaluate the influence of microstructure on the abrasive wear resistance of steel subjected to soil abrasion.

c) To evaluate the influence of soil constitution on the abrasive wear performance of such heat treated steels.

d) To carry out accelerated wear testing in the laboratory and evaluate the transferability of data between field and laboratory tests.

e) To analyse the surface deformation and wear characteristics of worn samples.

f) To produce a ranking order of steel microstructure for use in different soil conditions.

CHAPTER 2

LITERATURE SURVEY

ABRASIVE WEAR

The subject of wear is a complex one embracing many disciplines. Unambiguous relationships between the magnitude of wear and applied factors can only be obtained as the result of careful analysis of the whole tribological system, as wear may take many forms, depending on the applied conditions and the nature of the materials involved.

Wear encountered in industry covers many quite different engineering situations and operating conditions, and it can be dangerous to overgeneralize about these. Surveys carried out, however, all produce similar results (Eyre 1979) and show that the following wear types are most widely encountered:

Abrasive	50%	Fretting	8%
Adhesive	15%	Chemical	5%
Erosive	8%		

In some situations the amount of wear that may be tolerated may be small (piston rings); in others, a considerable amount of wear is acceptable, eg. mineral processing equipment. The most severe problems occur in equipment that is in contact with soil, rock, and minerals as the working material, ie. the metallurgical, mining, construction and agricultural industries.

Scientific material selection and design changes cannot be made without first understanding something of the abrasive wear process, how material properties affect abrasive particle contact and material removal, and how component geometry affects abrasive particle contact, loading and sliding.

Wear is rarely catastrophic, and for this reason has not been as extensively researched as corrosion and fatigue. It is thus not surprising that numerous definitions and classifications exist.

DEFINITIONS

The Research Group on Wear of Engineering Materials of the Organization for Economic Cooperation and Development has defined abrasive wear as *wear by displacement of material from one of two surfaces in relative motion caused by the presence of hard protruberances on the second contact surface; or by the presence of hard particles either between the surfaces or embedded in them.*

Eyre (1979) extends this definition by including abrasive particle shape and hardness, as well as the damage observable: *Abrasion involves the removal of material from a surface by the mechanical action of an abrasive which has an acicular profile and is harder than the surface being worn, with damage taking the form of parallel grooves running in the rubbing direction.*

Although more precise than those which may be found in dictionaries, these definitions do not take into account all the variables in an entire tribo-system. Indeed, abrasive wear may be brought about by relatively soft or rounded particles moving in a random pattern not necessarily producing surface scoring (or parallel grooves); it can result in changes of the surface without material removal such as phase changes and recrystallization, and in this way influence the mechanisms of material loss.

Possibly the most useful definition is the one put forward by McQueer (1985), which states that *abrasive wear should best be regarded as any damage or alterations occurring at the surface of a solid component due to the relative motion across that surface of particles capable of cutting or grazing it.*

More specific terminology has emerged from studies of abrasive wear and is used to describe the severity of abrasive wear, specific combinations of abrasive and wearing material, or the relative properties of the abrasive and the wearing material.

CLASSIFICATIONS

In abrasive wear situations, sand, ore, or rock for example, contact the part surface or is located between two parts that tend to crush it. In the area of abrasive wear, there are at least three subforms of this phenomenon, first proposed by Avery (1954) and which have since then been generally accepted (Borik 1970, Eyre 1979):

1. Low-stress abrasion
2. High-stress abrasion
3. Gouging abrasion

Low-stress abrasion is defined as a condition in which the stresses imposed on the abrasive particles do not exceed their crushing strength, ie. particles are transported along the surface with both a rolling and sliding action. This condition occurs typically in moving soft moist earth, for example, in ploughing a field. It may also include pumping sand slurries from a dredge and even handling dusty air, and is often referred to as two-body abrasion.

High-stress abrasion, or three-body wear, occurs when two wearing surfaces, such as a grinding ball and the liner of a ballmill, come together in a gritty environment with enough force to crush the abrasive particles entrapped between them, ie. abrasive materials are deliberately broken down into a smaller size, and the stresses are quite high. This situation may also arise in engineering bearings if a hard wear debris is produced in situ or if abrasives are accidentally introduced from an external source.

Gouging wear represents a condition in which rocks or other coarse abrasive materials cut into a wearing surfaces with considerable force, producing deep gouges and removing large particles from the surface.

Misra and Finnie (1980) attempted to classify abrasive wear processes in more detail by presenting different descriptions of two- and three-body abrasive wear: two-body abrasive wear was classified as a process where a *rough surface or fixed abrasive particles slide across a surface to remove material*, and three-body abrasive wear as

one where particles are loose and may move relative to one another and possibly rotate while sliding across the wearing surface. In the latter case two surfaces are not necessarily required as they may be so far separated that the mechanical properties of one surface have no influence on the wear of the other surface. Three-body abrasive wear was thus further classified as being either 'open' or closed' : 'Closed' three-body abrasive wear occurs when loose abrasive particles are trapped between two sliding or rubbing surfaces close to one another; 'open' three-body abrasive wear occurs when the surfaces are far apart or when only one surface is involved in the wear process. This type is further subdivided into the three groups mentioned in the beginning, with the same criteria for the stresses the abrasive is subjected to. The classification is summarized below:

	two-body		
Abrasive wear -		closed	
	three-body -		low-stress
		open	- high-stress
			gouging

Misra's classification of low-stress open three-body abrasive wear is thus equivalent to two-body abrasive wear as defined by Avery, Borik and Eyre; to prevent misinterpretation and confusion these terms will only be referred to if absolutely essential.

Richardson (1967) classified abrasives as being either 'soft' or 'hard' to differentiate between wear caused by an abrasive of hardness equal to or less than that of the worn surface - a 'soft' abrasive, and that caused by an abrasive harder than the worn surface - a 'hard' abrasive. Fortunately, no ambiguity seems to be apparent here.

MODELS

Khrushchov and Babichev (1956) were the first to demonstrate that the volume wear of pure metals is inversely proportional to their hardness, but they and later workers (Richardson 1967) showed that the constant of proportionality varied for different groups of materials such as pure metals, alloys, plastics and ceramics (Fig. 1).

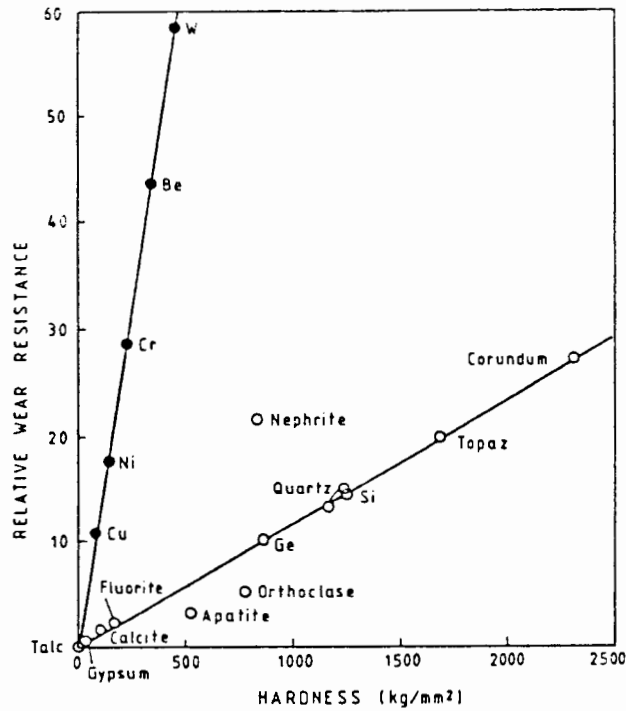

FIG. 1: Wear resistance versus hardness for some pure metals and minerals (60).

Simple models which explain the behaviour of pure metals have been proposed by many authors. An expression for the volume of material removed was developed by Rabinovicz (1961) who approximated the abrasive grit by a cone. The volume of material removed is then given by

$$V = K \cdot \frac{\text{Load} \cdot \text{Sliding Distance}}{\pi \cdot \text{Bulk Hardness}}$$

This model accounts well for the observed dependence of volume wear on sliding distance and applied load, but other wearing parameters are concealed in the wear coefficient, K, which has been given a physical definition but is actually a factor of ignorance (Avery 1981). The equation was modified by Mulhearn et al (1962) to take into account differences in particle shape and contact frequency, but still suffered from several idealizations.

When wear resistance is plotted against hardness, pure metals fall on a straight line passing through the origin, whilst alloys hardened by heat-treatment lie beneath this line on straight lines of lower gradient (Fig. 2). From their studies Khrushchov and Babichev (1958) concluded that the wear resistance of structurally heterogeneous materials was equal to the sum of products of the wear resistance of the individual components and their corresponding volumetric quantities,

$$E = Be_1 + Ce_2 \quad ,$$

B and C being the volume fractions of the components and e_1 and e_2 their relative wear resistances. Furthermore, they realized that the hardness value to be considered was not the annealed hardness but that of the worn surface, i.e. the fully work-hardened hardness.

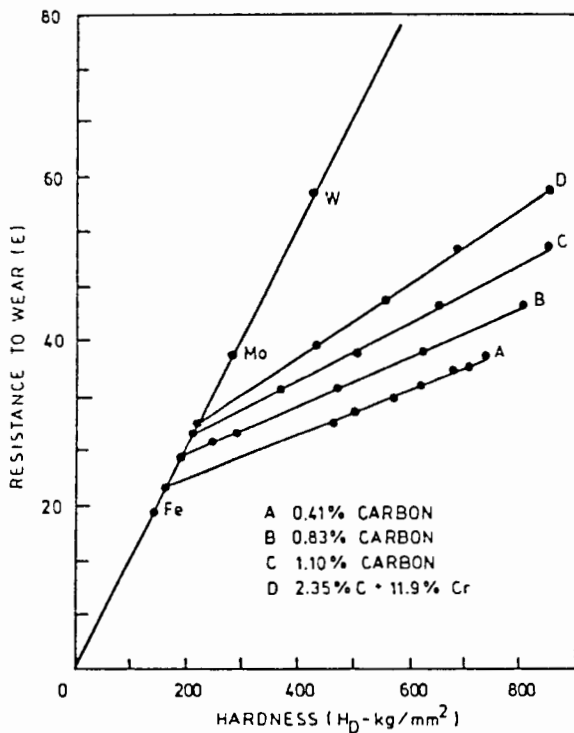

FIG. 2: Effect of hardness of metals on abrasive wear resistance (13).

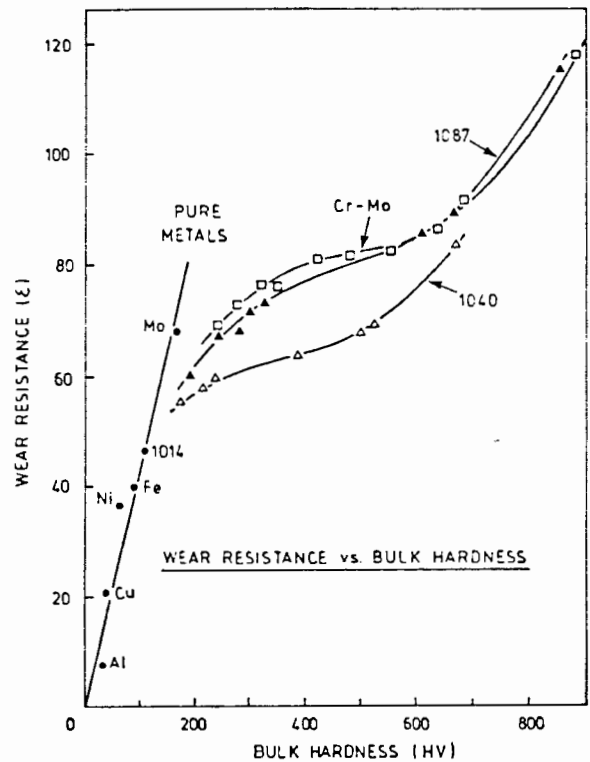

Fig. 3: Wear resistance as a function of hardness for three steels tested, together with a number of points on the pure "pure metals" line (69).

Various workers (Richardson 1967, Moore et al 1972) showed that a surface can undergo severe plastic deformation and strain-harden

during wear, eventually reaching the limiting hardness during the wear process. The correlation between wear resistance and worn surface hardness was found to be improved, yet the models did not completely account for the effect of volume wear or mechanical properties of the surface material.

Later work by Mutton and Watson (1978) showed that the relationship between wear resistance and hardness for different carbon steels is better described by a series of sigmoidal curves; curves for higher carbon steels being found to lie above those for lower carbon steels in agreement with Khrushchov (Fig. 3), and from this deduced changes in wear mechanisms. They also pointed out that for a eutectoid steel transformed at different temperatures, the compositions and properties of the phases are given by the tie lines on the phase diagram at the respective transformation temperatures, and that therefore very little differences in either the volume fractions or the wear resistances of the components may be expected.

Misra and Finnie (1981) observed that the proposed linear relationship for annealed hardnesses depended strongly on abrasive particle size; only for one size (34 μm) did the relationship hold true.

The inability of simple models to explain the results for heat treated steels suggests that metal removal is strongly affected by factors other than hardness. Different microstructures of the same hardness behave differently in wear, and various attempts have been made to relate wear resistance to other properties.

Larsen Badse (1969) used a power law incorporating the strain hardening exponent from the true stress/strain curve of pure metals in an attempt to show that abrasion resistance (E) was proportional to either bulk or surface hardness and exponential,

$$E = CH_e^n ,$$

thereby (i) assuming that all metals and alloys can be fitted equally well by a single stress-strain curve described by $\tau = KE^n$, and (ii) inherently attributing f.c.c. metals ($n \rightarrow 0.5$) such as copper and nickel a higher wear resistance than b.c.c. or h.c.p. metals ($n \sim 0.1 - 0.2$) of equivalent hardness. These trends do not appear in any of the published work.

Torrance (1980) proposed a plastic model modified to allow for elastic effects and deduced an expression relating abrasion resistance to metal hardness and Young's modulus. The predicted results were reported to agree closely with a wide range of published results, but Torrance himself suggested that the method used contained cyclic arguments.

The Rabinovicz model was extended by Moore (1985) to include matrix strength and fracture resistance by taking into account the summed probability of wear debris formation (K_1), proportion of groove volume removed (K_2), and abrasive particle shape and critical attack angle (K_3):

$$\text{Volume wear/unit area} = \frac{K_1 \cdot K_2 \cdot K_3 \cdot \text{Applied Load} \cdot \text{Sliding Distance}}{\text{Worn Surface Hardness}}$$

Although in general a fairly good correlation between theoretical and experimental wear rates was found, the model underestimated the actual volume loss by a factor of two or more.

The problem of wear prediction was approached on the basis of the molecular-mechanical theory of friction and fatigue by Kraghelskii and Loginov (1983), who derived wear factors for elastic and plastic contact, microcutting, and running-in wear. The wear rate of the friction couple is calculated by means of these factors once the kind of frictional mode is estimated mathematically. The disadvantage of this method is that it determines the wear resistance of a material under highly specific conditions, where even slight changes in the operating conditions, such as temperature or pressure variations, require the recalculation of wear factors and a reassessment of friction interaction.

It is thus clear that wear resistance is not an intrinsic material property of a metal in the same way as Young's modulus or thermal conductivity, although these and other properties may have an appreciable effect on wear resistance. The mathematical models tend to rely on bulk material properties as a guide to abrasive wear resistance, yet do not really take into account that the amount of wear will depend upon the particular friction couple and the environmental conditions existing at the interacting surfaces.

WEAR MECHANISMS

'Wear mechanisms' is the collective name for microevents by which wear - according to a chosen definition - takes place. Whatever the tribo-system under consideration, the basic phenomenon in material removal is fracture, which can take place by four mechanisms: shearing of junctions (entailing continual formation, plastic deformation and fracture of adhesive junctions between tribo-partners), micro-cutting (removal of material by the formation of chips, shavings etc.), impact (requiring a high peak stress of short duration and a high angle of incidence), or fatigue. The tribo-fracture event is generally preceded by, interacting with, or followed by other phenomena like heating, plastic deformation or corrosion, none of which, however, are specific to wear (Vingsbo 1979).

The current trend is towards what might be loosely termed a fatigue process, where fatigue is defined as the damage resulting from repeated loading. Modern concepts of wear mechanisms are mostly concerned with material properties in order to find quantitative relations between wear and test variables, i.e. wear equations, but there is as yet little agreement as to the controlling influence. Suh believes fracture properties to be the most significant, a view also held by Moore and Richardson. Boas and Rosen, however, have concluded that the workhardening index is important for abrasive wear - as previously suggested by Larsen-Badse, whilst on a more fundamental level, Rigney sees stacking fault energy as major factor (Clayton 1980).

Basic mechanism of abrasive wear

The basic mechanism of abrasive wear has been the subject of many investigations. Khrushchov and Babichev (1958) identified two processes taking place when abrasive grains make contact with the wearing surface (Fig. 4):

- (i) the formation of plastically deformed grooves (*ploughing*), and
- (ii) the separation of metal particles in the form of microchips (*cutting*).

By the microploughing action of an abrasive particle, material within the wear path is plastically deformed and pushed to both sides of the wear groove. In the ideal case, volume loss due to a single passage of an abrasive particle becomes zero but can, however, occur due to the action of many abrasive particles. Material may be ploughed aside repeatedly by passing particles and may break off by low cyclic fatigue (Ludema 1981). Murray, Mutton and Watson (1979) suggest that in practice, wear in this situation would probably occur through a mechanism of delamination as proposed by Suh (1980), similar to the process of microcracking outlined by Zum Gahr (1983), which may occur when highly concentrated stresses are imposed by abrasive particles, particularly in the surface of brittle materials. In this case large wear debris are detached due to crack formation and propagation. Spurr (1981) demonstrated the nature of deformation occurring during ploughing by sliding indentors against specimens made up of laminae of plasticine of different colors (Fig. 5), correlating well with the subsurface deformation actually observed in metals (Moore and Douthwaite 1976).

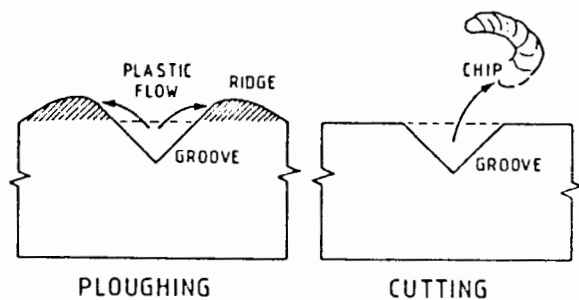

FIG. 4: Schematic diagram showing two mechanisms of groove formation in metals (68).

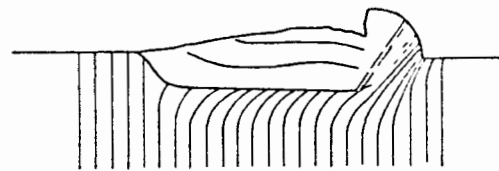

FIG. 5: Sketch showing the nature of deformation during ploughing (96).

By contrast, microcutting ideally results in a volume loss equal to the volume of wear grooves with no ridges left flanking the groove. The grooves are sharply defined and the chip has the appearance of a machining chip. Total removal of this sort would give rise to the most severe rate of abrasive wear in ductile materials.

Material removal involving plastic deformation occurs for a wide range of both material and abrasive properties. Microchip formation and ploughing have been observed during the wear of materials with predominantly brittle properties. This may occur because temperature

risers of about 800 °C at the wear surface increase the materials ductility.

Moore (1980) states that groove formation involves plastic deformation for both ductile and brittle materials, and because of strain hardening, an extensive region below the surface is also plastically deformed. The hydrostatic stress system associated with abrasive particle contact will, in ductile materials, oppose void formation and growth, thus raising the ductile fracture stress and strain, such that the strains at worn surfaces may be very much higher than in conventional deformation processes. The wearing surface deforms plastically until the fracture strain is reached at the surface, thus aiding the formation of microchips and other wear debris. This explains Mutton and Watson's observation that in the case of ploughing, the wear debris may be chips formed by a metal cutting component or by tearing of heavily cold-worked material in the deformed layer. In brittle materials, the associated tensile stresses behind the abrasive can cause cracks to propagate from the plastic zone, causing greater volume wear because of the contribution of material removal by fracture adjacent to grooves. Thus, although plastic deformation occurs for both ductile and brittle materials, fracture may be the rate controlling mechanism. It must also be noted that the stress system from adjacent particle contacts may produce cyclic deformation of material between contacts, leading to strain softening, particularly in hardened and tempered steels (Richardson 1967).

The ploughing/cutting transition is not a sharp one, but depends on the system variables, the effects of which have been investigated by various workers, but where, it seems, no general agreement has yet been reached.

PROPERTIES OF THE ABRASIVE

Abrasive type and relative hardness

It has been well established that an abrasive must be significantly harder than a metal if it is to wear the metal to any extent. Richardson (1968) showed that for many combinations of metal and abrasive, abrasive wear falls rapidly when the abrasive hardness H_a

falls below 1.25 times the hardness of the metal H_m , i.e. $H_a > 1.25 H_m$ for wear to occur (Fig. 6). Torrance (1981), by applying a simple slip line field model to the abrasive-metal contact, has mathematically shown that abrasive wear should become significant when $H_a = 1.16 H_m$, and should rise rapidly to a maximum and level out when $H_a = 1.26 H_m$, a result verified by Misra and Finnie (Fig. 7).

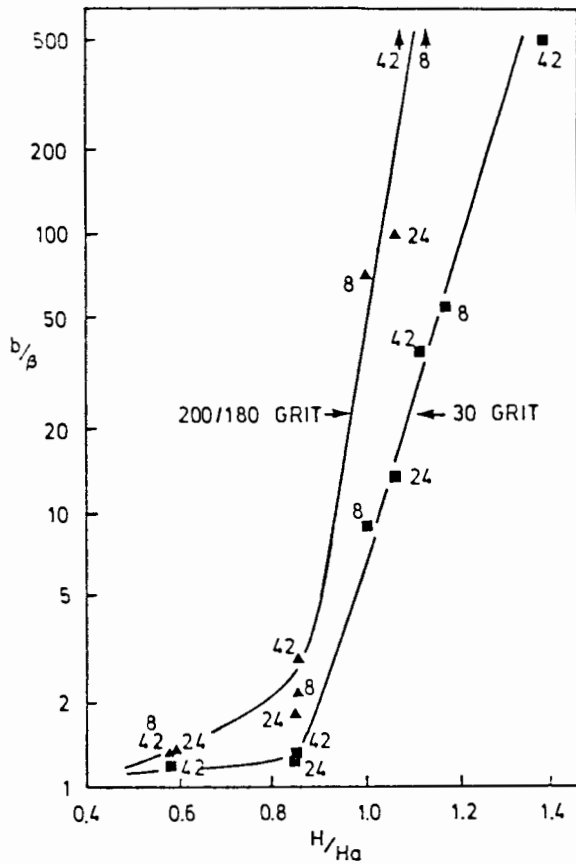

FIG. 6: The increase in wear resistance of martensitic steels on glass abrasive, showing the effect of relative abrasive hardness; b is the relative wear resistance on glass, β is the relative wear resistance on 180 grit SiC, H is the hardness of the test material, H_a is the hardness of the abrasive (59, after Richardson).

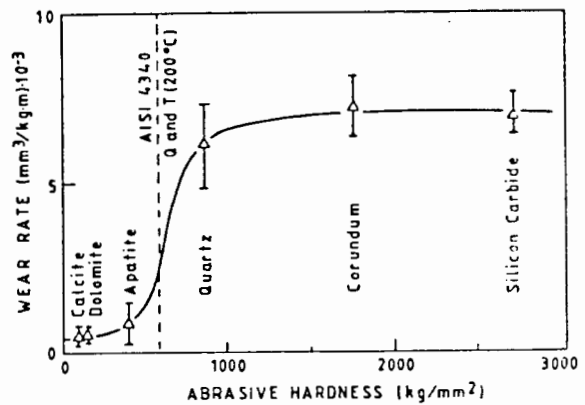

Fig. 7: Wear rate as a function of abrasive hardness for AISI 4340 sample, quenched and tempered at 200 °C and abraded by 250 μ m size particles (55).

For low speed sliding abrasion, the relative hardness is probably the most important of the properties governing the wear mechanism. Hard abrasives can act like a cutting tool and produce grooves, craters and scratches in the metal surface, resulting in rapid material removal. Although relatively little work has been done with softer abrasives, work by Larsen-Badse (1983) indicates that these are not able to plastically indent the metal surface, but cause wear by a contact fatigue mechanism.

Particle size and shape

Both laboratory and field tests have shown that volume wear is greater for coarse abrasives. For lab tests, the wear rate increases rapidly with particle diameter up to a critical size of 100 μm , after which it increases at a much reduced rate (Fig 8). Misra and Finnie (1981) found that the abrasive particle size effect is neither affected by prior cold working of the material nor changes in load or speed. The observation that coarser particles cause greater wear rates may be explained by the height and size distribution of contacting particles. For fine particles a proportion of the applied load is carried elastically by particles which are prevented by height and size distributions from making plastic contact with the surface material; additionally, loose wear debris will hinder the contact of smaller or less deeply indenting abrasive particles.

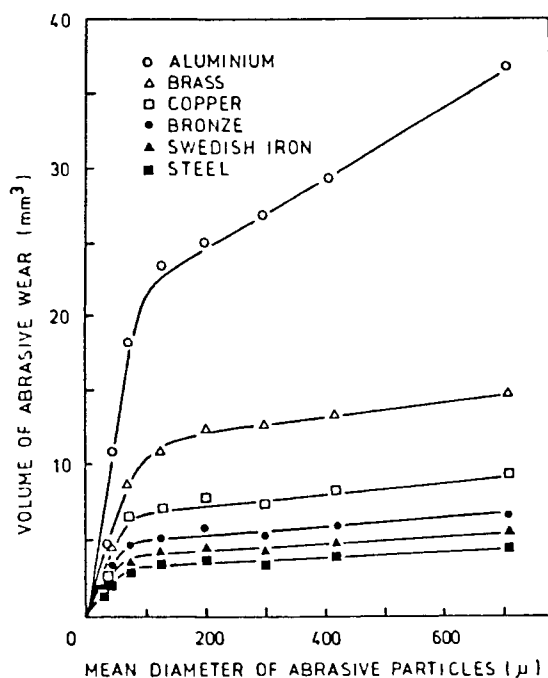

Fig. 8: The effect of abrasive grit size on volume wear (59, after Nathan and Jones)

Plastic flow of the abrasive may occur when it is softer than the wearing material, but becomes significant as the ratio of the two hardnesses exceeds unity. Whilst plastic flow tends to blunt abrasive particles, fracture may well regenerate cutting facets and produce free abrasive fragments. Because the probability of suitably orientated defects is higher, fracture is more likely to occur in

higher loaded coarse abrasives than fine abrasives. This also accounts for the more rapid deterioration of fine abrasives with increasing sliding distance, as these tend to blunt by plastic flow whereas the coarse abrasives tend to fracture. Furthermore, fine particles have been found to be bonded less firmly to the backing paper, thus facilitating pickup by the wearing material and decreasing the wear rate.

Spurr (1981) suggests that particle shape rather than diameter determines wear, as only a fraction of the abrasive particles are suitably shaped and oriented to give rise to wear particles. It had been established by Mulhearn and Samuels (1962) that on commercial abrasive papers, coarse particles were mostly equiaxed, whereas there was a much higher proportion of acicular particles for fine papers. Laboratory tests have revealed that increases in particle angularity can dramatically increase the wear rate. Swanson and Klann (1984) used particle image analysis to characterize particle angularity and proposed an empirical equation relating abrasion rates to particle morphology. The predicted volume losses were found to correlate 'fairly well' with experimental results.

It should be obvious that the wear rate will be influenced by the number of contacts resulting in material removal. In abrasive wear by loose particles, only about 10% of the particles result in wear, the remainder roll or slide across the surface. For commercial abrasive papers over a wide range, only 6-13% of possible particle contacts have active cutting points (Eyre 1979). It has recently been shown by Torrance that metal will generally be removed by all the abrasive particles whose attack angles are greater than approximately 30° . As the metal hardness increases, the stresses on the abrasive tip rise until plastic collapse has reduced its attack angle θ to 20° , below which scratching should mainly be eliminated, as the coefficient of friction has then reached its minimum. Wear will then occur by other mechanisms.

Murray et al (1979) found that, although mixed modes of groove formation can be expected on either side of the critical attack angle, as θ is decreased, there is a transition from long, free continuous chips, through segmented, discontinuous chips, to pure ploughing,

the latter two modes giving rise to increasing amounts of secondary debris. They also found that as the hardness of the metal is increased, the critical attack angle decreases, and that there is thus an increase in the number of particles on an abrasive paper suitably disposed to cause machining. They concluded that in the fully annealed state steels behave in a similar manner to pure metals displaying a wear mechanism that is predominantly ploughing, while in the fully hardened condition wear takes place predominantly by cutting due to the relative ease of chip formation as a result of the loss of ductility associated with increasing hardness (Fig. 9).

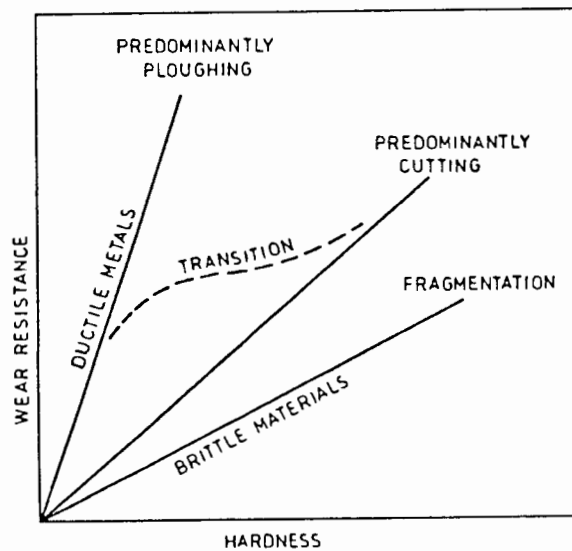

Fig. 9: Three possible relationships between metal hardness and wear resistance predicted by considerations of plowing, cutting, and spalling mechanisms of groove formation. The dotted curve shows the transitional behaviour for steels (68).

PROPERTIES OF THE WEARING MATERIAL

The hardness of a material is clearly an important property in determining abrasive wear as it controls the depth of indentation of the abrading particle; this aspect has been dealt with in the preceding sections.

Metallurgical structure such as grain size, dispersed phases, lamellae etc. have a considerable influence on the mechanical properties of a material and hence its wear behavior. Different microstructures behave differently during wear, but it is generally recognized that

most ferrous martensitic materials exhibit abrasive wear resistance superior to ferritic, pearlitic or bainitic materials (Fig. 10).

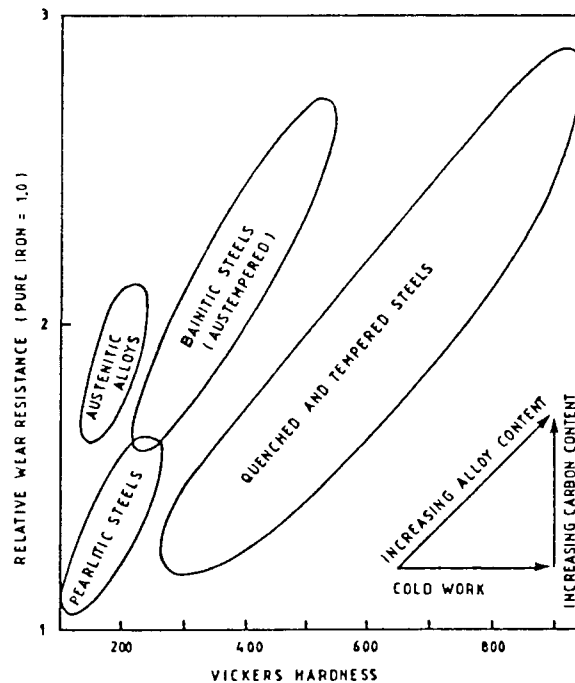

Fig. 10: Effect of structure, heat treatment and alloy content on the wear of steels (worn on $90\mu\text{m Al}_2\text{O}_3$ abrasive, 1 MN/m^2 applied load (after Moore)).

Abrasion resistance has been shown to be independent of grain refinement (Kwok and Thomas 1983), as in abrasive wear grain boundaries are ineffective barriers to dislocation movement (Kashcheev 1982).

The wear resistance of steels may be improved by the addition of alloying elements, the prerequisite being that these significantly alter the microstructure to be effective (Murray et al 1979). Increasing the carbon content increases the hardenability, bulk hardness and volume fraction of alloy and iron carbides; the addition of chromium improves both strength and toughness but has only a small effect on improving wear resistance. Molybdenum may reduce the severity of temper embrittlement during heat treatment which sharply reduces fracture toughness and wear resistance in Fe-Cr-Mn-C alloys, as continuous films of high carbon interlath retained austenite transform to iron carbide and thus promote unstable crack propagation. At higher temperatures, carbides grow and eventually spheroidize, decreasing the tendency of crack initiation.

Manganese additions, by decreasing the interlamellar spacing in pearlitic steels, were found to reduce sliding wear (Clayton 1979), to increase the fatigue crack initiation endurance limit (Gray et al 1985), and to increase the abrasion resistance of martensitic high chromium irons (Zum Gahr and Eldis 1980), thus possibly influencing the cyclic fatigue mechanism in abrasive wear as proposed by Zum Gahr (1983).

Correlations between wear resistance and retained austenite in low alloy steels were observed by various authors. Kar (1981) studied a series of secondary hardening steels and found bainitic microstructures containing substantial amounts of retained austenite to exhibit better wear resistance than quenched and tempered martensite at similar hardness levels, and suggests that this may be related to the presence of high internal stresses in the quenched microstructures, thereby contributing to their poor fracture toughness and consequently low wear resistance. On secondary hardening, the relative increase in wear resistance could be related to the extent of replacement of primary cementite by thermodynamically more stable alloy carbides (Cr, Mo, V).

Salesky and Thomas (1981) suggested that high strength/high toughness microstructures, such as an austenite-martensite microduplex structure, lead to optimum wear resistance. Kwok and Thomas (1983) confirmed these findings by showing that dislocated lath martensite with continuous interlath films of retained austenite were preferential to a bainitic/martensitic or ferritic/pearlitic microstructure, and put forward that the enhancement of wear resistance by the retained austenite may be due to (i) the transformation induced plasticity (TRIP) that can absorb energy for fracture and produce local compressive stresses that impede microcrack formation; (ii) the presence of the ductile austenite film between the martensite laths discouraging microcrack nucleation and propagation; (iii) an increase in work-hardening coefficient through TRIP or (iv) retention of retained austenite at lath boundaries preventing brittle lath boundary carbide formation. In the case of low carbon structural steels, the distribution and morphology of retained austenite (interlath, intralath, thin continuous film vs. block) may be more important than the amount present.

In the presence of dispersed phases, the wear mechanisms (in a specific tribo-system) become a complex interplay of relative hardnesses of the abrasive, carbide and matrix; the sizes and shapes of the abrasive and carbide, the distribution of the latter, and of the strength of the carbide/matrix interface. Abrasive particles may blunt or fracture, by-pass the hard phase, run over it, push it into or loosen it from the matrix.

Richardson (1968) concluded that the dispersed phase becomes effective as a discrete component against soft abrasives when its size is about the same, or greater, than the depth of indentation of the contacting abrasive particles. As the size of the carbides decreases, they may be predominantly dug out rather than worn. Even when the abrasive is considerably harder than unstrained carbides (which can flow plastically and therefore work-harden), they become less effective as the relative size of the grooves is decreased, because their effect in reducing the fracture strain is greater than their contribution to bulk hardness. On the other hand, hard particles may reduce the volume wear of soft matrices because of the effect they have on the deterioration of the abrasive (Moore 1980).

With extremely brittle materials wear volume greater than groove volume can occur, as plastic deformation of the matrix induces displacement incompatibility between the hard particles and the matrix, creating an interfacial stress. When this stress exceeds the bond strength of the matrix/particle interface, cracks nucleate and material may be lost due to fragmentation. For two-phase materials such as steel, cracks nucleate rather readily at the interface (Spurr 1980). Low coherency between the two phases may also cause larger carbides to be plucked from the surface leaving craters in the wear scar, i.e. increasing wear volume (Murray and Watson 1978).

For cemented carbides profound changes in removal mechanisms take place as the relative hardness increases (Larsen-Badse 1983). Hard abrasives form grooves and craters in the surface and remove material by gross plastic deformation; softer abrasives subject the surface to very localized deformation which results in gradual extrusion of the binder material, cracking of carbide grains (as the compressive stresses are relaxed), and the formation of subsurface fatigue cracks.

The nature of the bonding of carbides to the matrix may well be a factor controlling wear resistance. Kar (1981) states that the de-

gree of cohesion between austenite and cementite is greater than that present between martensite and cementite; furthermore, austenite also impedes microcrack formation. The coherency between precipitates and matrix increases as the shape of the carbides changes from spheroids to needles, which resist pullout most efficiently but produce plains of weaknesses in the bulk material leading to macrofracture and spalling (McQueer 1985). Larsen-Badse found that finely dispersed hard particles influence the flow stress and increase abrasion resistance according to a Hall-Petch relation, (i.e. abrasion resistance inversely proportional to the square root of cementite spacing) (Fig. 11). Thus a high volume fraction of fine acicular coherent carbides strongly bonded to the matrix, their size dependant on abrasive particle size, may be considered most beneficial with respect to abrasion resistance. Further improvements in wear resistance may be achieved by replacing the primary carbides with alloy carbides during secondary hardening.

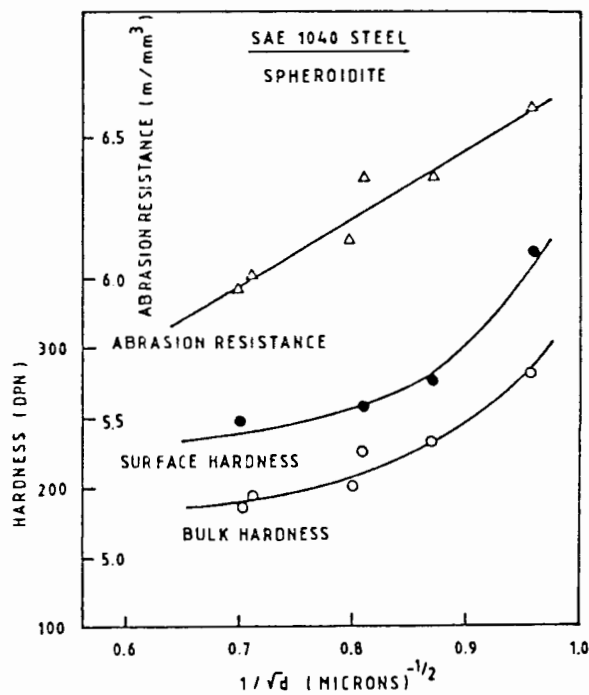

Fig. 11: The dependence of wear resistance of spheroidal cementite steel on the particle spacing (59).

The interaction of these mechanisms has been discussed by Sare (McQueer 1985), who concludes that the wear rate is a balance between carbide removal and matrix removal, the slower of the two governing the overall wear rate. In low-stress abrasion, the carbides will retain sufficient support to resist pullout and

fracture as preferential wear of the matrix will be slight, and gradual attrition of the carbides will thus control the wear rate. Preferential wear of the matrix becomes more significant under high-stress conditions, and carbides will be more easily pulled out and fracture - the wear of the matrix thus governing the rate.

VARIABLES IN THE WEAR ENVIRONMENT

Load

Misra and Finnie (1979,1980,1981) confirmed previous findings that, in two-body abrasive wear, weight loss varies linearly with nominal load except for slight deviations in the higher load ranges, and found that in low-stress open three-body abrasion weight loss increases linearly after an initial non-linear stage, which may be due to the lower degree of constraint experienced by abrasive particles in this wear mode. Furthermore, wear-rates in low-stress open three-body abrasion were seen to be an order of magnitude lower than in comparable two-body abrasion tests (Fig. 12).

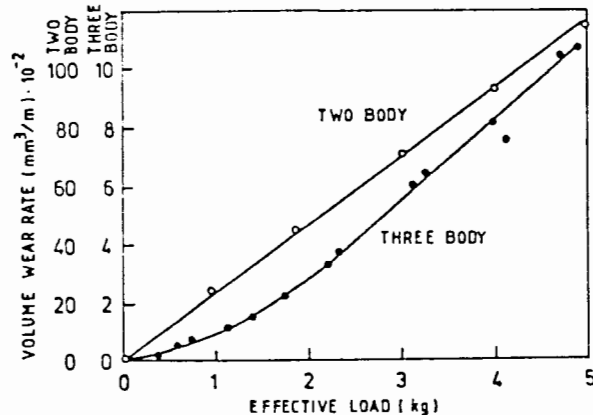

Fig. 12: Volume wear rate as a function of the effective load on the specimen for AISI 1020 steel abraded by 250 μm SiC particles under two- and three-body conditions (54).

Moore (1974) states that volumetric wear is directly proportional to the nominal load up to a critical load which is determined by the onset of massive deformation of the specimen or instability of the abrasive surface. For brittle materials, the wear mechanism changes at this point from plastic deformation to fracture. Critical loads

vary for different materials as a function of fracture toughness/hardness, and also depend on abrasive particle shape, being lower for more angular particles. Additionally, as abrasives themselves are usually brittle, their abrasiveness will be influenced by the way in which they fail: abrasive failure may produce fine powdery fragments tending to clog the abrasive surface, or large angular flake fragments which tend to increase the wear rate.

Sliding velocity

Various workers have measured the change in wear rate with speed in both the field and in the laboratory on bonded abrasives and loose sand. The results of these tests vary considerably and are summarized in the following table (Data from Moore and McLees (1980), Misra and Finnie (1980) and Moore (1986)):

<u>Test</u>	<u>Speed increase (m/s)</u>	<u>Max. change in wear-rate (%)</u>
Field	0.25 - 2.00	-30 to +57
	2.00 - 3.00	+ 2 to +5
Laboratory (Bonded Abrasive)	0 - 0.0001	constant
	0.0001 - 0.1	+20
	0.1 - 0.2	+10
	0 - 2.5	+13 to +140
Laboratory (Loose Sand)	0.26 - 5.00	+800 to +1000

Increases in wear rates with speed are more marked for large grit sizes over the lower end of the range and also for more wear resistant materials. Moore (1986) states that the effect of speed on wear against fixed abrasive is associated with the wearing material's dynamic properties through strain rate sensitivity, resulting in changes in the wear mechanisms. Frictional heating, expected from increasing sliding speeds, is, however, discarded as a serious problem: Moore (1971) deduced temperature rises of 325 - 900 °C in the grit-chip contact zone and concluded that, although the physical, chemical and mechanical properties of the contact zone may be modified, the overall effect on abrasive wear is likely to be small.

Velocity variation may also cause the particle loading to change, either through contacting particle flow dynamic effects or through longer range effects associated with strain rate stiffening of the abrasive medium.

Humidity

Moisture exerts a significant influence on the state of soil particles as well as on the properties of surface layers of the metal. The effect of water (or other fluids) on wear rates varies for different materials, material/abrasive combinations and test configurations, but generally wear increases with increasing moisture content. The exact phenomena are not clearly understood, but Russian workers offer one feasible explanation: Wedge-shaped microcracks are known to form during deformation of a solid body as a result of defects in the crystal lattice and other effects. The development of such cracks is accelerated by the pressure of adsorption layers penetrating into and widening them. These adsorption layers resist the natural tendency of the cracks to close up in the absence of external forces, and in the presence of periodic deformation and an active adsorbent medium, the process of destruction of the metal surface is considerably hastened, especially at low wear intensities.

Moisture may, however, also play the part of a lubricant on a friction surface and reduce wear rates. Furthermore, water and water-vapor have a significant effect on the brittle fracture resistance of abrasive (oxide) particles themselves, such that fracture of the abrasive may modify particle contact conditions, sometimes causing the abrasive to become more efficient (Moore 1986).

Wear path length and specimen size

Weight loss is found to increase linearly with sliding distance after initial non-linear behaviour. The non-linear portion may correspond to plastic deformation and strain hardening of the surface to equilibrium hardness (Richardson 1968), or embedding of abrasive particles in the surface of a specimen leading to an initial in-

crease in its weight under open three-body abrasive wear conditions (Misra and Finnie 1981). For wear in soils, Richardson has demonstrated that the effective sliding distance is somewhat greater than the linear distance travelled by a (roughly spherical) stone over the tool surface because of rotation of the stone.

Specimen size may influence abrasive wear due to conditioning and deterioration of the abrasive. Larsen Badse (1972) suggested that the critical specimen length corresponding to maximum wear depends on the applied conditions: if the grit-life is much shorter or longer than specimen contact, the effect on wear data will be small, but may become appreciable when the two values are about the same. Additionally, in some situations abrasive may be trapped between two surfaces in motion, or recirculate, so that its size and shape characteristics change over a period of time.

The foregoing review of the basic mechanisms of abrasive wear, material and abrasive properties, variables encountered in the wear environment, metallurgical structure etc. emphasize the wide range of variables which can influence the abrasive wear of materials. In summary, it should be noted that the effects of these various variables on two-body abrasion, three-body abrasion and erosion are very similar for the three different wear processes (Misra and Finnie 1980), and that, in some cases, the data from one wear process can be used to predict the behaviour in another process.

WEAR OF TILLAGE TOOLS

Tillage is the essential operation of ground preparation with the objective to pulverize, invert, move, cut, or otherwise manipulate the soil. The action of the soil on the tillage tool surface is dynamic and complex; depending on operating conditions, wear mechanisms may range from high stress to low stress abrasion.

Consequences of wear are high maintenance and tool replacement costs (the latter estimated to be of the order of R 30m in South Africa , CSIR 1982), increased fuel consumption, deminished soil breakup, or even loss of production if tillage is inefficient over extended periods.

Parameters affecting the wear rate of soil engaging tools are interdependent, but may be broadly classified according to design, soil, and material properties. Although some of these variables have been studied in detail, a better understanding of the tribosystem as a whole is essential to achieve longer tool life and higher cost-efficiency.

TOOL TYPE, DESIGN AND FORCES ACTING

The selection of a tool from a large variety of available types depends on the operating conditions and tillage requirements such as soil type, working depth and width of cut: Moldboard plows are used in heavy (clayey) soils, whilst disc plows are usually preferred in stoney soils. Chisel points are designed to operate at 150 - 300 mm, ripper points at 300 - 450 mm and subsoilers at depths greater than 450 mm.

Soil properties vary with depth, and for significant reductions in wear rates, the prime requirement for soil engaging components is a hardness in excess of 80% of the abrasive hardness (but a toughness high enough to prevent brittle fracture). The ranking order of different materials, however, can change even in a single condition, and lead to contradictory conclusions (Richardson 1967).

During soil working, the tool is subjected to three principal forces (Moore and McLees 1980):

- (1) The *draft force*, a combination of
 - (a) the resistance of the soil to bulk deformation, and
 - (b) inertia forces on the tool, i.e. soil to metal adhesion;
- (2) the *penetrometer force*, due to the resistance of stones contacting the tool to movement through the fine soil aggregate;
- (3) the *impact force* on the tool when it collides with stones.

Tool wear is governed by the load-time history of these forces (Table 2), which in turn depends on the tool shape, working depth, speed, and soil properties such as moisture content, soil compaction and cohesion.

<u>FORCE</u>	<u>MAGNITUDE (MNm⁻²)</u>	<u>DURATION (s)</u>
Draft	0.01 - 0.1	always effective
Penetrometer	0.5 - 2.0	0.5 - 5.0
Impact	2.0 - 250	< 0.001 / contact

Table 2: Load-time history of basic forces operating during tool working (62).

Materials design and selection both contribute to successful improvements in the life span of components. The avoidance and reduction of wear can often be more effectively and economically achieved by an improvement in design than by employing more wear resistant material.

Models treat the tool as a wedge section (McKyes and Desir 1984), but actually such a condition of the blade is preserved for only a small fraction of the total operating period (Fig. 13), as the cutting edges quickly wear to a parabolic shape. The degree of bluntness depends on both the initial geometric form of the blade and the physicochemical properties and state of the soil (NTIS 1984), and leads to a substantial compaction of soil ahead of the tool with consequential increases in the draft force and wear rate. Tool efficiency is also diminished as the implement tends to rise instead of being drawn into the soil. Miller (1980) claims that cross rolling and martempering heat treatments increase the strength and toughness

to levels where durable thin tillage tools can be produced. His suggestion that these would maintain a low sharpening angle by taking advantage of the tool edge tendency to become parabolic (Fig. 14) and so minimize the upward force and wear rate have been refuted by Cooper (1986), who established that a 25% increase in thickness (from 16 - 20 mm) resulted in a 22% reduction of length loss without any breakages (16mm = 15% breakage). Although this means a cost increase of 25% for material alone, total outlay would be reduced by 15% as replacement costs due to catastrophic failure become negligible. Cost efficiency is further increased by ensuring round mounting holes to prevent stress concentrations - and hence unwanted fracture - in regions of high bending moments.

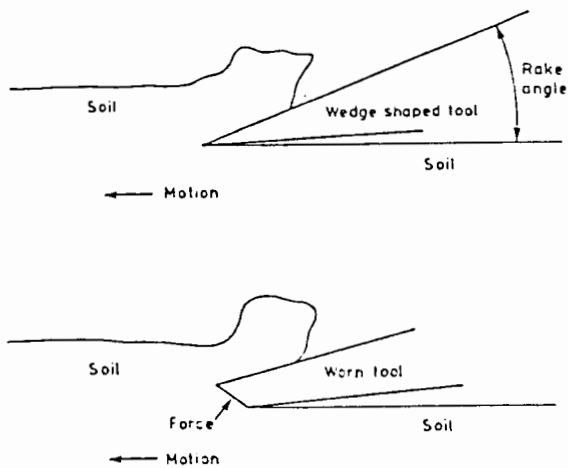

Fig. 13: Schematic wear of wedge shaped tillage tool (53).

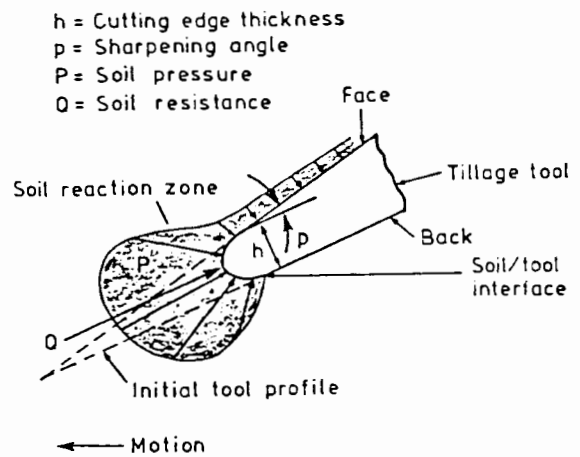

Fig. 14: Section through a stabilized uniform cutting edge showing the pressure diagram of the soil (53).

Cooper also investigated the influence of initial shape at the end of chisel points on wear and found that it should be similar to the typical one formed by the soil. A flat shaped point with a bottom undercut was found to maintain its angle of penetration, whereas points with the bevel located at the upper surface pass through a blunt stage during the formation of the final shape and show increased wear rates. McKyes and Desir (1984) studied the efficiency of tillage tool shape with respect to draft force and soil breakup, and concluded that a narrow tool with a rake angle of 30 - 45° should be used for soil rearrangement and loosening, but that a wide tool of lower rake angle between 20 - 25° is indicated if draft force and energy input are of paramount interest.

Russian workers (NTIS) measuring the soil pressure on various implements found that increases in the depth of plowing (all other factors remaining constant) lead to a sharp growth of pressure at the working edge of the tool (Fig. 15). This is associated with the increase in the force required for the deformation of the soil stratum being cut; also, the shear force on the stratum acts in the vertical plane and it obviously increases with depth. There is, however, no direct relationship between wear and pressure, which is explained by the fact that at points of maximum pressure and comparatively reduced wear, the sliding velocity of soil is not very high: deformational sliding takes place here, so that the velocity of relative displacement of the soil particles is much less than when kinematic sliding occurs.

Researchers generally agree that wear intensity does not increase proportionally with increases in tillage speed, e.g. 4.7 fold increases in velocity raised wear rates by between 5 and 12%, depending on the soil type (Fig. 16). The draft force, on the other hand,

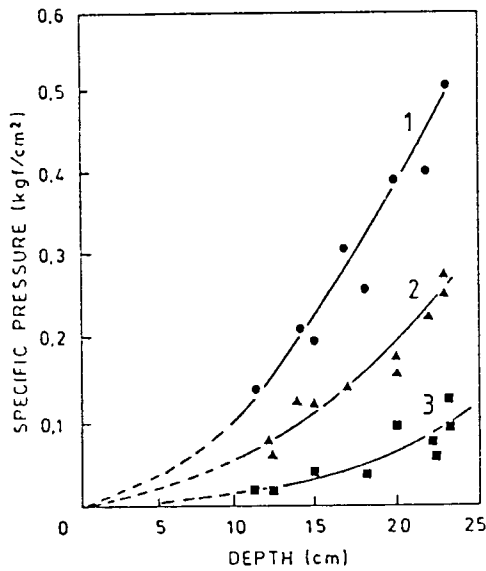

Fig. 15: Relationship between specific pressure at 1) the nose, 2) the heel of the plowshare, and 3) shin of the moldboard and depth of plowing (71).

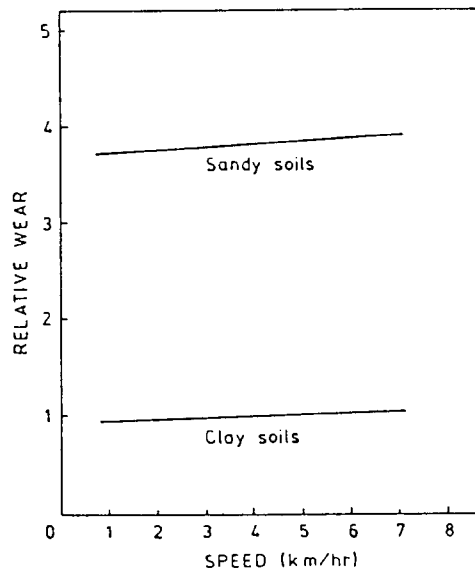

Fig. 16: Wear of a tillage tool as a function of speed (53).

may increase considerably; Moore and McLees (1980) cite inertia ef-

fects, change of soil shear strength with strain rate, speed dependence of soil failure pattern, visco-elastic effects and the rate of propagation of stress waves through the soil as possible reasons for this observation.

SOIL GEOLOGY AND MOISTURE CONTENT

Soil conditions not only influence the blunting of cutting edges, but also control the characteristic nature of soil movement over the tool. Thus, during plowing of sandy soils with a moisture content of approximately 3% plow shares are mainly worn out along the width, but at 10% moisture along the thickness of the top part (NTIS, Cooper 1981). Soil properties such as soil class, cohesive shear strength, moisture content and particle shape and size all affect the wear of the implement.

Wear rates vary considerably with location and farming practice. Cooper (1980) reports that the durability of plowshares varies from 4 ha for heavy soils containing rocks and sandy soils with hard gravel to about 100 ha for clay loam containing 10 - 25% clay. Chisel points last between 60 ha in dry sandy soils and 600 ha in soil with 10 - 25% clay content. Experiments conducted in the USSR also showed wear in sandy soils to be 8 - 10 times that in clayey soils, with heavy sandy loam being intermediary.

Whereas in sandy soil the destruction and removal of material takes place as a result of a continuous cutting and scratching action of the abrasive, it is due to repeated plastic and elastic deformation in clayey soils. Consequently, the characteristic of a material to resist wear in clayey soils is the capability of surface layers to withstand repeated plastic deformation, and in sandy soils, the hardness (NTIS).

There is rarely a single abrasive constituent in soil, but quartz is expected to be the most predominant phase on account of its widespread occurrence in granites and sandstones and its resistance to weathering. The relative abrasiveness of fragmented and crystalline quartz is 8 - 12 times that of siliceous rocks. It is not

certain whether the quartz in soils fractures during working, but quartz grains are believed to be chemically unstable once their diameter becomes very small, which is confirmed by the observation that quartz is not present in the very fine clay fraction ($< 0.2\mu\text{m}$) of soils (CSIR 1980).

Abrasive particles under contact execute mixed motions which include sliding, oscillation and rotation. Their relative displacement depends upon their dimensions and degree of cohesion. Particles of clayey and loamy soils are displaced 3 - 3.5 times faster in the active zone than particles of quartz sand, and those of a more drawn-out or elliptical shape remain in contact for a longer period because a considerably greater force is required for them to be ejected or to start rolling than for spherical or cubic ones. Research (NTIS) has shown that quartz particles of 1.6 - 2.0 mm diameter cause wear 1.5 - 2 times faster than smaller ones of size $d = 0.12 - 0.35$ mm despite the reduction in the total number of particles per unit area.

The presence of stones dramatically increases wear rates. Richardson (1967) found tenfold wear increases in soils of similar composition but different stone content. Miller (1980) states that in clay soils as little as 0.05% stones ($> 15\text{mm}$) can increase the wear rate by 25 times compared to stonefree soils, whilst a mere 20% increase is seen for sandy soils containing similar sized stones at the same level. Moore and McLees (1980) concluded that in soils with stones (2 - 40 mm diameter) the penetrometer forces are predominant in determining wear due to their magnitude (1 MNm^{-2}) and the high number of stone contacts (up to 500/m). Additionally, cultivation of soils with high stone content may lead to frequent breakage of the digging parts.

Vasil'ev (1958) and later Soviet investigators have attempted to rank soils according to their "wearing-out capability", i.e. the degree to which a soil causes wear when compared to a soil taken as standard, at a constant moisture content of 15%. Soils were classified according to their composition and divided into three categories comprising eight basic soil types. They stress, however, that

the graphical relationship obtained (Fig. 17) provides only a description of the relative effect of individual fractions on the coefficient of wearing-out capability and does not reflect their complex action.

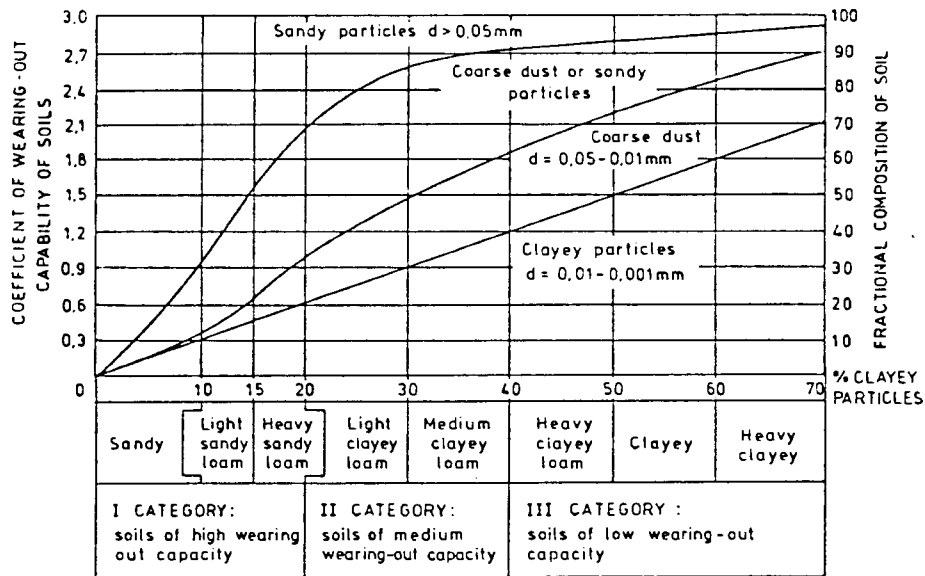

Fig. 17: Classification of soils according to their wearing out capability (71).

Changes in moisture content cause the intensity of wear to vary within wide limits for different soils; it is possible that under dry conditions the durability of plowshares may be the same for sandy and clayey soils. Moisture exerts a significant influence on the state of soil particles as well as on the surface layers of the metal, so that a reduction of the abrasiveness of soil particles and an acceleration of the surface destruction of the tool take place simultaneously.

For larger particles and low moisture content wear is reduced as a result of the force of separation of the adsorption layer around the contact area. Cleaving action of this layer in a microcrack may play a decisive role in the surface degradation (p. 24). Moisture also lowers the strength of the abrasive and promotes the breakup and crumbling of sharp edges. For 6 - 12% moisture, the reduction in the hardness and strength of the metal appears to be greater than

the reduction in strength of the abrasive particles. The final effect depends on the volume and quality of the adsorbent medium, which may be enhanced by acids and salts present in the soil (NTIS).

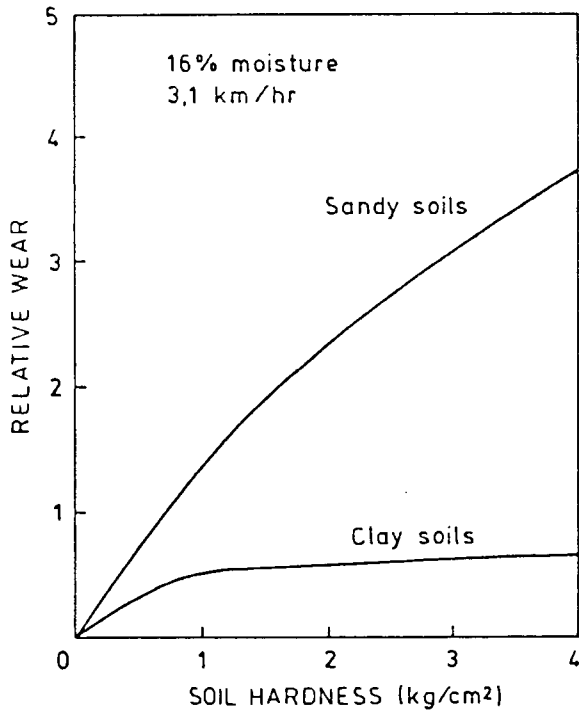

Fig. 18: Dependence of wear of a tillage tool on soil hardness (53).

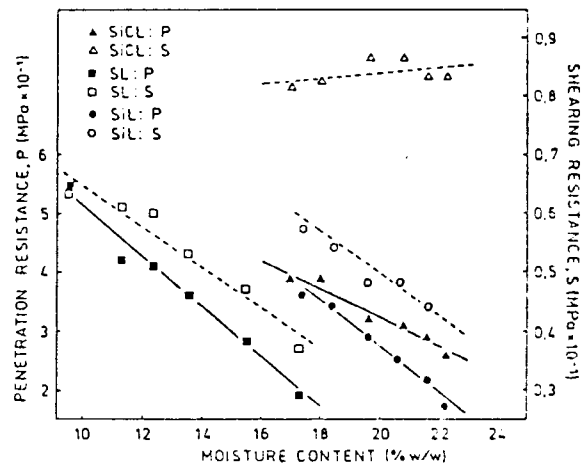

Fig. 19: Relationship between penetration resistance (P), shearing resistance (S), and moisture content for three soil types: SiCL = silty clay, SL = sandy loam, SiL = silty loam (11).

Wear increases with increasing soil hardness (Fig. 18). Ellen (1984) showed that a high correlation between moisture content and penetration resistance exists for all soils (Fig. 19) and advises the use of these parameters to find the optimum tillage conditions.

Clayey soils with low moisture content become very hard, so that under dry conditions wear may be five times higher than at 12 - 15% moisture. Here, moisture acts as a lubricant: both the forces of frictional contact and the rate of relative displacement of particles are reduced, resulting in diminished material removal. On increasing the moisture content of sandy soil, the opposite phenomenon is observed: the pressure and sliding velocity of particles increase up to a maximum as a consequence of an increase in cohesion (Fig. 20). Further increases in moisture result in a decrease of the

cohesive forces and a break in colloid formation, and thus reduced wear (NTIS).

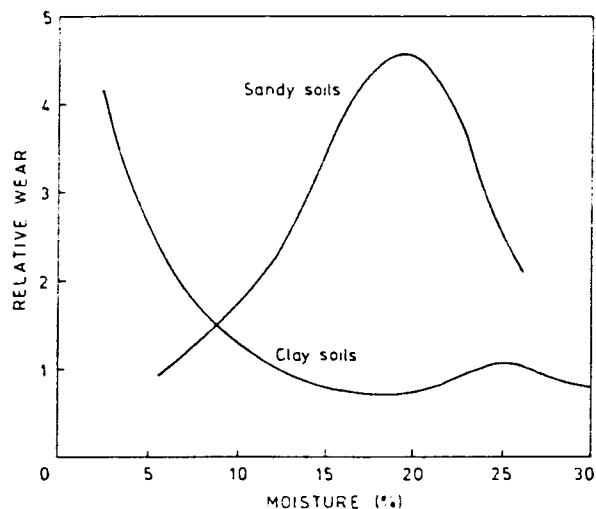

Fig. 20: Influence of moisture on abrasive wear of tillage tools (53).

Russian scientists investigating the relationship between wear intensity and moisture content of different soils found that soils causing more wear had lower values of "maximum molecular moisture retention capacity", and vice versa (Fig. 21).

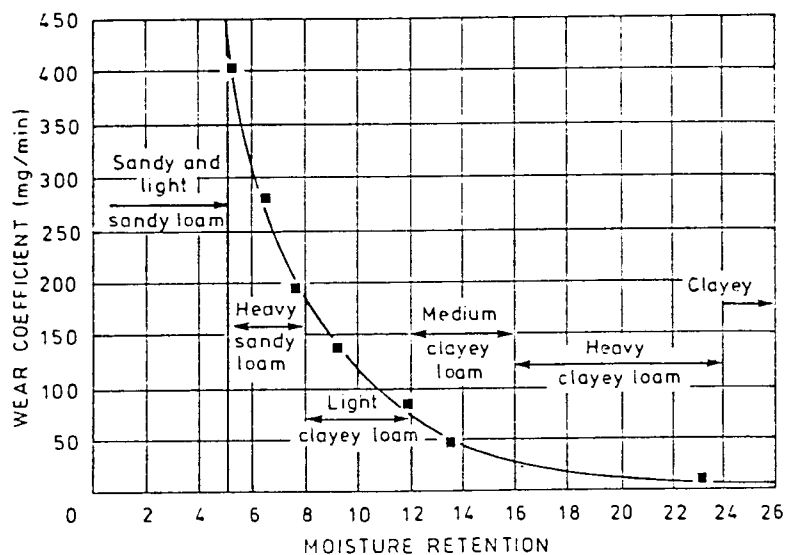

Fig. 21: Relationship between the wear coefficient and maximum molecular moisture retention capacity of soils (71).

Ellen concluded from his studies that the most efficient use of energy per unit area (EA) or unit volume (EV) depends on the tillage requirements and soil moisture content. EA applies to energy consid-

erations regarding the degree of pulverization, whilst EV refers to the efficiency of the depth of seedbed preparation. Low EA values were found at low moisture content for all the soils tested, whereas higher moisture contents are required for energy-efficient seedbed preparation for all except clayey soils (Fig. 22).

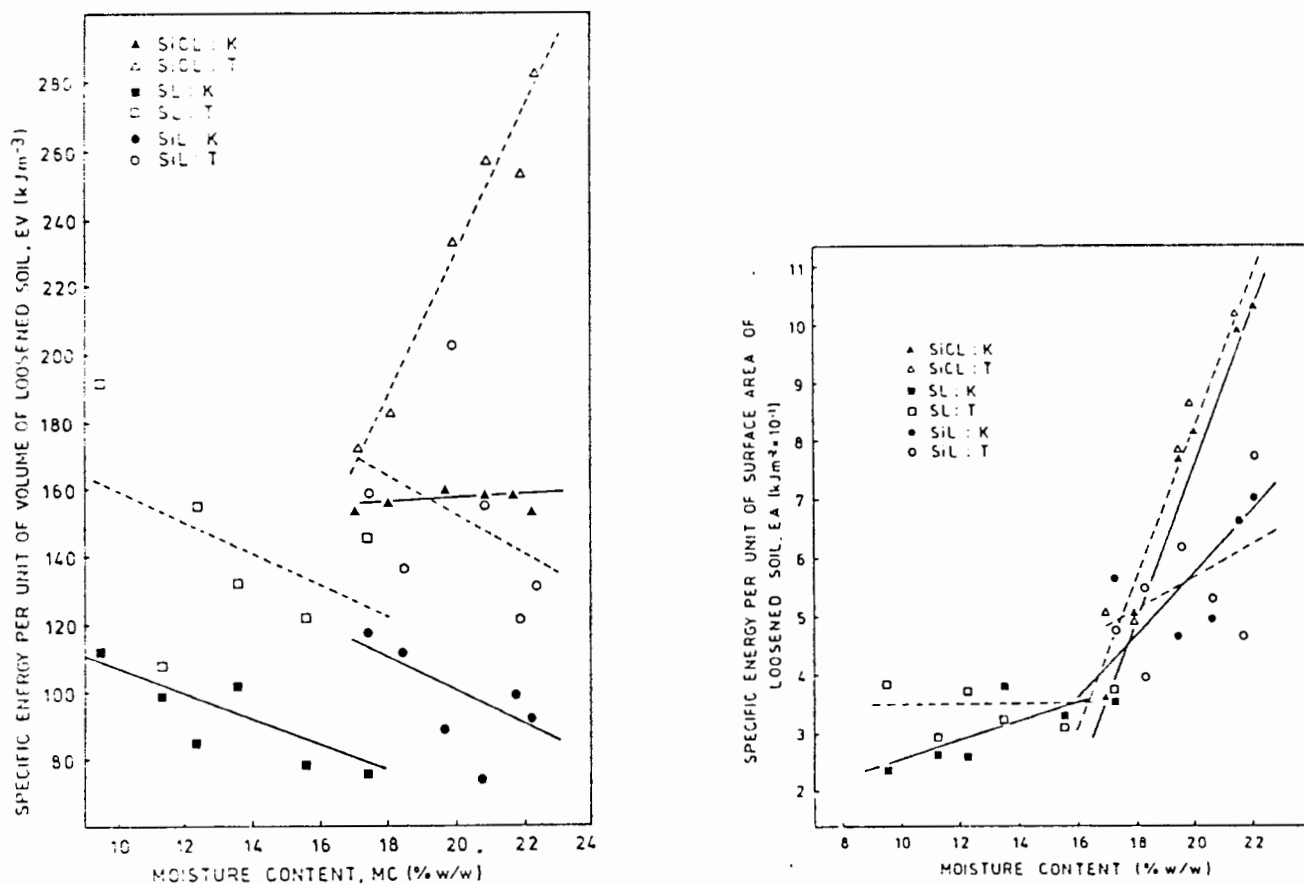

Fig. 22: Relationship between specific energy per unit volume (EV) and unit area (EA) of loosened soil and moisture content for combinations of soils type and tillage tool. K = knife, T = tine. Soil types as for Fig. 19 (11).

MATERIALS FOR GROUND ENGAGING PARTS

Materials used in tillage equipment require strength and toughness to resist distortion and impact, and hardness to resist wear. However, high hardness and toughness are mutually exclusive; improved wear resistance is accompanied by reduced impact. In general, steels have adequate strength and toughness but are much softer than soil abrasives, and so have poor wear resistance.

The materials typically used for agricultural soil working parts are heat treated eutectoid carbon steels or silico manganese steel at a hardness of about 42 - 49 HRC. At this level the wear resistance is usually reasonable and the notched tensile and fatigue strength at a maximum. High hardness materials or surface treatments are only employed when contact stresses are low and when frictional characteristics are important, such as on moldboard plows.

Cooper (1986) is of the opinion that not one of the steels presently used by South African manufacturers (EN 45, AISI 1046, AISI 1069, boron treated steel) is recommendable for tillage applications. Problems associated with improper heat treatment - coarse grain, decarburized surface, mixed products of austenite decomposition, as well as untempered martensitic and normalized structures - are found throughout locally produced parts (Quirke 1983), and may be aggravated by the fact that steel compositions vary between batches.

The use of boron treated steels has several advantages. Because boron raises the hardenability of carbon grades, lowering the carbon does not sacrifice strength developed by heat treatment; compared to higher carbon alternatives, better toughness at equivalent strengths is achieved. Furthermore, the tendency for quench-cracking and distortion during heat treatment is reduced as the steels selftemper while quenching. Other attributes of boron steels are shorter annealing cycles, better machinability, improved hot and cold working characteristics, and the ability to use lower alloy contents. Additions of only 0.0015% boron have been found to produce the best combination of strength and toughness (Kishen Koul and McVicker 1976). Although boron steels are widely used in Scandinavian countries where low temperature brittleness may pose a problem, Cooper found the wear resistance of a 15B37 (0.37%C) steel to be similar to or lower than that of AISI 1085, and advises its use only if hardness lies between 48 - 52 HRC. She recommends that a high carbon (0.9%C) steel with additions of around 1% manganese should be adopted for all parts, as such a steel, properly heat treated to a hardness of 35 - 45 HRC, was found to produce the best performance and manufacturing efficiency on account of its resistance to overheating and decarburization.

Various workers propose the (more expensive) austempering process instead of a conventional quench and temper to improve toughness at high hardness levels, whilst Farmer (1979) and Price (1983) advocate surface treatments to combat wear. The very wide range of treatments available may be divided into three main groups (Eyre 1979):

- (1) *Surface deposition*, involving the addition of extra material, usually of a composition different to the surface of the base metal, e.g. hardfacing;
- (2) *Conversion coatings*, where changes occur within the original surface, e.g. tufftriding;
- (3) *Surface hardening*, entailing a change in composition which enables an increase in surface hardness to be achieved through heat treatment, e.g. carburizing.

Of these, only hardfacing is usually employed in the agricultural sector, as the other processes tend to be unsuitable, be it because of high porosity, low bond strength, or insufficient material available for wear.

Iron based hardfacing alloys generally contain high levels of carbon and/or boron to promote carbide and/or boride formation during solidification, and have a hardness in the range of 40 - 60 HRC. Application of hard facings by welding (gas, shielded metal arc, gas tungsten arc or metal arc) may influence the wear resistance by causing changes in the structure of the coating. A high deposition rate can cause dilution of the hard facing by the parent metal and dissolution of the constituents; to avoid these effects it is traditional practice to produce multilayer deposits. The heat may also affect the temper and hence hardness of the base material if hardfacings are applied to previously heat treated components.

The advantage of hardfacing is the possibility of carrying out extremely localized rebuilding of components involving small or large areas either on site or in a repair shop, and that by proper placement of hard metal one can provide for uneven wear that will result in a selfsharpening action. However, a study of the costs involved showed that such processes were unlikely to be economical besides giving inconsistent performances. It was partly for this reason that the National Institute of Agricultural Engineering in Britain focussed its attention on engineering ceramics, possessing excellent wear resistance by virtue of their extreme hardness. Alumina, the most cost effective, albeit not hardest material, has been success-

fully bonded to various steel carriers using high performance epoxy resin adhesives (Foley 1984). Alumina-tipped spring tine points and subsoiler shins are commercially produced in the UK; their wear rates are claimed to be five to eight times lower than those for conventional steel components. They are, however, only suited for use in abrasive soils containing few stones and at shallow working depths where impact damage is minimal. It is unlikely that impact damage can be overcome completely, and thus improvements in both design and materials are essential to assure longer life spans.

One final point, often overlooked, is that a proportion of wear-out can be avoided by the correct use and maintenance of equipment. Causes of avoidable wear include incorrect installation and application, as well as operator incompetence and negligence in maintenance. Awareness of these and the other factors mentioned could lead to considerable increases in durability and efficiency at almost no extra cost to the farmer.

WHITE LAYERS AND ADIABATIC SHEAR BANDS

'White layers' or 'adiabatic shear bands' are generic terms used to describe worn surface layers or internally formed streaks in a variety of ferrous and non-ferrous alloys. They are revealed as white (non-etching) bands under the optical microscope, usually after processes involving high deformation rates, and have two common characteristics: a very high hardness, and an extremely fine structure compared to the bulk material.

Early reported observations of white layers were made in the period 1910 - 1920 with respect to brittle surface layers produced by rubbing on steel wire ropes and in wire crushing experiments. Since then, they have been observed in a variety of situations, and their occurrence divided into three general or main areas (Griffiths 1984):

- (a) White layers found at the surface of engineering components after removal from their environment (piston rings and liners, rail heads);
- (b) those formed as a result of machining processes (grinding, drilling);
- (c) those resulting from laboratory experiments (pin on disc).

The phenomenon of adiabatic shearing has been most frequently observed and most assiduously studied in ordnance applications, involving projectile impact and penetration, penetrator shatter, fragmentation of explosively loaded cylinders, and associated punching experiments.

APPEARANCE

White layers found on worn surfaces are usually of a patchy and irregular nature, and appear featureless even at very high magnifications (x 50000). Their most notable property is their very high hardness, 700 - 1200 HV, which is considerably harder than can be produced by any conventional hardening process. Thickness ranges

from a few microns to half a millimetre; the depth increasing as conditions become more abusive. The interface between the white band and the matrix may be sharply demarcated - such as in cast irons (Eyre and Maynard 1971) - or a transition zone, with a slightly lower hardness than the matrix, may exist (Glenn and Leslie 1971). Microprobe analysis has not revealed any concentration gradients between the bands and the substrate.

Rogers (1979) notes that their formation is not restricted to metals of a particular crystal structure, and that their occurrence has been observed for a number of non-ferrous materials, among them brass, zirconium alloys, titanium, and a variety of aluminium alloys.

Research by Wingrove and Wulf (1973) and Staker (1980) in fragmentation and penetration studies indicates that an increase in both the hardness of the parent metal and the deformation rate increases the susceptibility to formation of white etching layers, and that a 1%Cr-1%C steel containing a fine distribution of small carbides in a martensitic matrix is less apt to white etching layer formation than a 1%C steel with the same hardness.

STRUCTURES

There are numerous indications that the white etching bands may have different structures in different materials and that structure may even differ in parts of the same band. Wingrove (1973) demonstrated the great sensitivity of the final structure of bands to the prior structure - bands appear to form relatively easily in tempered and untempered martensitic structures, but bainites and pearlites are also susceptible. (Hau-Bracamonte and Wise 1982).

Adiabatic shear bands have been classified as either deformed or transformed bands, the division being based on hardness and etching characteristics. Deformed bands are narrow bands of intense shear without structural transformation and are mostly observed in non-ferrous metals (or in metals of coarse structure), whereas the transformed type is principally observed in ferrous alloys (Staker 1980). Rogers (1979) points out that this classification is artificial, as the type of band formed is highly dependant on the

specific deformation conditions; with respect to worn surface layers alone, seven different types have been identified (Griffiths 1984).

In the early studies of white etching bands their structure was assumed to be martensitic, mainly on the basis of hardness and white etching characteristics. Since then evidence has been emerging which both supports and casts doubt on the validity of this assumption. Among others, Eyre and Baxter (1972) found that the white etching bands did not display the tempering characteristics of martensite, even when heated to above normal tempering temperatures. Only heating to above the austenitization temperature caused a disappearance of the white layer, discounting the possibility of their being martensite only.

The diversity of reported results and the difficulty of a conclusive analysis of the structure of white etching zones seems to arise for two reasons. Firstly, because of the small physical dimensions of shear bands, analysis by conventional methods is difficult and quantitative results are difficult to obtain. Secondly, there is the possibility that not all shear bands are the same, as augmented by differences in the tempering behavior (Wingrove and Wulf 1973).

The microstructure of white etching bands is quite generally extremely fine and essentially equiaxed. Cell or grain sizes range from one to several tenths of a micrometre, and the misorientation between them is either not reported or ranges between 2 - 15°. Structures have been evaluated by x-ray, electron diffraction and Mossbauer techniques, and fairly strong evidence exists to support each of several positions taken on the structure. Wingrove (1971) found that lattice spacings corresponded closely to essentially tetragonal martensite, even though the microstructure, as revealed by transmission electron microscopy, was not typical of martensite. Electron diffraction patterns obtained by Glenn and Leslie (1971) indicated a cubic structure with a lattice parameter approximately the same or smaller than that for normally observed ferrite, whilst several studies suggested a significant amount of retained austenite to be present (Bedford et al 1974, Eyre 1979, Hau-Bracamonte and Wise 1982). Komarev and Medvedev (1983) concluded from their studies

that the white etching bands on diesel engine cylinder liners was a complex heterogeneous, highly differentiated structure containing both austenite and martensite.

White layers examined contained no identifiable carbides, rather, carbon must be contained in solution, as carbides are found to precipitate after ageing in air for 30 minutes (Newcomb and Stobbs 1983). Bedford points out that the increased hardness is caused primarily by the fineness of the grain and may not be a function of a special transformation product, as extrapolating hardness data to a grain size of $0.1 \mu\text{m}$ by a Petch-Hall type equation has shown.

The basic nature of these shear bands is thus still somewhat in doubt. The early postulation that the white layers were untempered martensite has neither been proven conclusively nor rejected. The bands might be expected to show a structure somewhat different to quenched martensite and have a higher hardness due to additional work hardening effects and a high density defect structure; on the other hand, evidence suggesting a cubic structure may indicate some form of heavily deformed, fine grained ferrite (Bedford et al 1974).

FORMATION MECHANISMS

Three general mechanisms associated with white layer formation have been identified (Griffiths 1984), but it is most likely that they cannot be separated and act in combination:

- (a) *Plastic flow*, which produces a homogenous or very fine grained structure;
- (b) *Rapid heating and quenching*, which results in transformation products;
- (c) *Surface reaction with the environment*, such as nitrogen, carbon or oxygen enrichment, which, however, is not deemed essential.

Necessary prerequisites for adiabatic heating during deformation are that the deformation be restricted to a localized region, that large

strains occur, and that the deformation rates be high. Such conditions are encountered during the processes listed previously, i.e. surface grinding and rubbing, machining, punching operations, projectile-target impact and explosive fragmentation.

Adiabatic shearing is governed by the temperature sensitivity of the flow stress of the material - a decrease in the flow stress occurs when the heat generated during straining becomes larger than the increase due to strain hardening, its work-hardening exponent - pure metals with relatively high rates of work-hardening such as copper, aluminium and pure iron do not tend to form adiabatic shear bands even under high strain rate conditions, and the volume specific heat (Staker 1980).

Direct (Moore 1971) and indirect evidence (Eyre and Maynard 1971, Mashloosh and Eyre 1985, Yingjie et al 1985) indicates temperature rises of between 700 - 1050°C to occur during abrasion, and Woodward (1978) has observed melting at the projectile target interface during ballistic studies. Hau-Bracamonte and Wise (1982) have shown that pearlite can transform to austenite during cutting despite the extremely high heating rates ($6 \cdot 10^5$ °C/s) and short times (1.5 - 5.5 ms), with the intense deformation assisting the diffusional processes required for transformation, and Me-Bar and Shechtman (1983) calculated the cooling rates in the bands (subjected to strain rates of $3 \cdot 10^5$ s⁻¹) to be of the order of 10^7 °C/s over a period of less than 100 μs.

Most authors suggest similar mechanisms for the formation of the structures observed. Temperature and pressure rises cause a transformation to austenite, which, under conditions of continuing plastic deformation at very high strain rates, is then rapidly quenched to form a host of different microstructures with most of the structural aspects of martensites. The dense dislocation tangles observed in the final structure may be generated in two ways: (a) during deformation of the austenite, subsequently inherited by the martensite as times are too short for recrystallization; or (b) deformation of the martensite may continue after the transformation so that the resulting structure does not resemble conventional martensite.

A fundamental problem associated with transformed bands is the absence of carbides, as calculations show that dissolution and diffusion times are several orders of magnitude slower than known times

of shear band formation. Rogers (1979) postulates that during the intense shearing at high temperatures, the carbide particles are themselves plastic and sheared by a similar amount, reducing their equivalent thickness to a few atom layers that would readily dissolve. The carbon would then be retained in solid solution, being bound to lattice defects such as dislocations and vacancies that were produced by the deformation process. This mechanism would explain the apparent resistance to tempering of white etching bands. Newcomb and Stobbs (1983) also found that the white layer on the running surface of a railway line contained carbon in solution, but thought it very unlikely that the rail-wheel contact could produce temperatures sufficiently high for austenitization. They concluded that the pulsed subsonic shear stress cycle induced by the wheel contact was of the right form to lead to successive contacts of mobile, carbon free dislocations with carbides, and that the white layer was more probably ferrite containing dislocations supersaturated by carbon transfer from the carbides. However, the actual difference between a supersaturated ferrite and a ferritic martensite may only be a matter of semantics (Bedford et al 1973).

Research has produced a rash of confusing, if not contradictory evidence, and because of the breadth of deformation conditions under which the formation of white bands is observed and the variety of metals in which it is seen, it is difficult to draw very many useful conclusions. On the whole, white etching bands are associated with a deterioration in the performance of engineering components because of their brittleness. Fractures of both conventional modes, cleavage and ductile by means of void growth and coalescence, have been observed and may prove to be an important means of locating fracture paths in fragmentation. White layers at machined surfaces are detrimental to fatigue and stress corrosion cracking and are associated with catastrophic wear in rubbing situations. Penetration and penetration resistance are also adversely affected. More encouraging reports, however, come from their 'use' in the automotive industry (Komarev and Medvedev 1983), where it was found that complex alloying (V, Mo, Ti, Cu) made for more uniform formation of the white zone on cylinder liners, giving it higher strength and better adhesion to the base, so that better service properties could be obtained.

WEAR TESTING

The two major reasons for wear testing are

- (a) to assess the relative performance of competitive, commercially available materials, and
- (b) to determine the wear performance of components with respect to their design or materials of construction (Moore 1986).

Because test conditions vary widely, several test methods, each of which would have a high correlation with some service performance, may be required. The demands for a meaningful wear test, according to Feld and Walters (1975), are reproducibility, differentiability, and transferability. This means that test conditions have to be selected in such a way that the wear results are reproducible, that different material grades give clearly differentiated values, and that the quality grading obtained corresponds to practical applications. However, as Eyre (1979) points out, because of the large number of variables, there is a considerable controversy about the value of wear testing procedures, which tend to fall into three major groups.

(1) *Service Tests* duplicate real service conditions and provide the final answer, as the data generated is absolute and can thus be used to predict or estimate the component life. However, such tests are difficult to monitor or control because of the time scales involved, and increasing costs of (often specially manufactured) parts, equipment and manpower make them very expensive. Examples of such tests may be found in the works of Richardson (1967), Moore and McLees (1980) and Cooper (1986).

(2) *Simulative Rig Testing* is carried out in order to reproduce those variables that are suspected to contribute to wear in service. The requirements for such tests, with respect to agricultural wear, were stipulated by Richardson (1967). Test components should perform

the functional duty studied and must be homogenous within the wear zone. In addition, the wearing surfaces should be similar in shape, and soil type and condition uniform during the extent of the experiment. Nevertheless, even though statistical methods may be used to reduce errors, misleading answers may be obtained as not all the variables are simulated. This approach has been employed by various researchers, amongst them Swanson (1984), who used a soil wear probe patterned after an impact probe attached to a subsoiler, which was pulled horizontally through the soil at a preset depth.

(3) *Laboratory Tests* have the advantage that they may be performed under well defined and controlled conditions. Because they are less costly in time, materials and equipment than service or simulative test methods, data can be produced fairly rapidly, allowing comparison of many materials, treatments or designs. Test conditions can easily be changed so that the effect of specific variables can be evaluated. It must be kept in mind, though, that the data gathered is comparative only and should be used with caution, as such tests do not necessarily simulate the complete spectrum of environmental and loading conditions to which a component might be subjected.

Because of the numerous service conditions encountered, it is impossible to design a universal abrasive wear tester, and it is thus not surprising that a large variety of specialized testers exist. However, most designs are based on simple configurations, and can be divided into two main groups: those in which the abrasive is 'fixed' and those in which it is loose or 'free' with respect to the wearing specimen. The major difference between these two types is that for fixed abrasive tests, although the type and size of available abrasive is limited, the mechanics of abrasive particle/wearing surface is consistent over a wide range of loading conditions and material types. For loose abrasive tests there is a complete freedom of choice of the abrasive, including abrasive material from a service environment, but the contact mechanics can vary with load, counterface properties, abrasive shape and test material.

Thus, for instance, large rocks sliding over a surface would best be simulated by a fixed abrasive test as abrasive cutting points are not free to reorientate themselves in contact, whereas sand excava-

tion or handling may be better simulated by a loose abrasive test where the abrasive is uniformly small and free flowing.

Common *fixed abrasive test methods* are variations of the "pin on disc" type. In this test, a cylindrical or square specimen (2.5-6mm), which is dead weight loaded, follows a spiral track on a rotating disc of commercially bonded abrasive such that each element of the abrasive disc is traversed only once. The speed ranges from 0.025-7 m/s, but can vary during the test. The environment is usually air, but may be any other gas or liquid. Richardson (1967) utilized this device to study the abrasive wear of steels typically used in agriculture, and found the results to bracket those in actual field tests.

Similar procedures are employed for the "abrasive-drum" (Mutton and Watson 1978) and "abrasive-belt" methods (Allen and Ball 1981), with the pin describing a helix in order to be continually rubbed by fresh abrasive. The advantage of these tests is the elimination of speed differentials between the inner and outer edges of the pin as well as the disc.

Zum Gahr and Mewes (1983), amongst others, describe the use of a milling machine, where the specimen is loaded parallel to its axis and reciprocates in a non-overlapping pattern across commercial abrasive paper whilst simultaneously rotating about its axis. Gundlach and Parks (1978), of the Climax Molybdenum Company, suggested that this test could be used to simulate different types of abrasive wear simply by controlling the test parameters, and found that even though the obtained wear rates do not reflect those determined in actual industrial conditions, the test accurately discriminated and ranked materials according to their resistance to wear in service.

Common *loose abrasive test methods* include yet another modification of the "pin-on-disc" type (Misra and Finnie 1980), where a column of abrasive, contained in a tube, is pressed against a rotating metal specimen disc. Other designs are the "abrasive tank or bin" which permits the testing of large specimens, the "reciprocating plate" technique, where particles are introduced between two surfaces which are sliding over one another under load, and the "ball mill", which provides a convenient way of testing a large number of materials simultaneously and is said to give high reproducibility. The most pop-

ular and reliable device, however, has proven to be the "rubber wheel abrasion tester" (RWAT), which may be employed under wet or dry conditions. The procedure has since been standardized (ASTM standard practice G65). In this test, a stationary, rectangular specimen 76.2 x 25.4 x 6.35 mm is loaded against the edge of a vertically rotating rubber rimmed wheel 229mm in diameter with a force of 133N. The chlorobutyl rubber has a 60 ± 2 Shore A hardness. The test abrasive is round grain AFS 50/70 silica sand ($>150 \mu\text{m}$, $<425 \mu\text{m}$) and is gravity fed from a hopper (flow rate 250-305 g/min) to the interface between the specimen and the wheel, which is rotating at a speed of 200 rpm (surface speed 2.39 m/s). Each test consists of 2000 revolutions or a total sliding distance of 1436 m. (The wet sand rubber wheel test is very similar, with a tank of slurry encompassing the lower portion of the wheel. A detailed description of this test has been provided by Borik (1970), but will not be discussed here as corrosion is not considered an important factor in agriculture (Foley 1984)).

The disadvantage of such a standardized test is that it treats abrasion resistance as a materials property instead of a systems property - Swanson and Klann (1981) have shown that crushed quartz particles produce up to ten times the volume loss as foundry sand with similar particle size and that the ranking order may change. Still, Swanson (1984) found this test to adequately simulate the abrasive wear of materials studied in sandy fields having low moisture content, even though the frictional heat generated at the wearing surface (Bulk = 160°C after 6000 revs) may modify or soften the rubber and cause the abrasive particles to become embedded in the wheel, thus restricting their freedom of movement.

The problem with model tests, which are frequently used to cut down on time and money, is thus not their reproducibility or differentiability, but lies in the degree of uncertainty as to whether results obtained are applicable to original designs, i.e. their transferability. This problem is particularly pronounced in the case of tribological processes, where the number of influencing factors is so high that conditions of similarity do not provide a quantitative statement about the processes in the original system. In wear investigations, however, it is often not the numerical data but rather

qualitative statements which are of interest. Krause and Senuma (1982) state that good qualitative applicability frequently requires part fulfillment of similarity conditions, and propose that these should be determined by a system analysis. The tribological system factors should be the same in the model and the original, the most important ones to take into consideration being

- (1) the characteristic stress, i.e. the stress which acts decisively on the wear process, which is influenced by both
- (2) normal load and
- (3) friction force,
- (4) the depth effect of the stress, as this influences the size of the
- (5) contact area,
- (6) residual stresses, which depend on the geometry of the test specimens, heat treatment, surface treatment and machining,
- (7) the basic tribological structure, consisting of primary and secondary contact bodies, the environmental atmosphere and the interface media.

A relatively good applicability of test results can be expected when the wear processes in the model and the original system are similar. Examination of wear scars is helpful in determining the nature of abrasive particle motion, but does not give a complete picture of the types of material removal mechanisms that exist. Wear debris is a more sensitive indicator of wear mechanisms and operating conditions, but may not always be possible to collect. Their structure and properties can provide clues to the type of wear involved and the prevailing conditions during their formation. When the debris from two different test devices is similar, comparable wear situations can be expected (Rigney and Glaser 1982).

CHAPTER 3

INITIAL STUDIES

INTRODUCTION

It became clear from the literature survey that, in order to determine the wear resistance of ground engaging materials, it would be necessary to employ a testing method which either duplicates real service conditions or one that reproduces those variables suspected of contribution to wear in service.

Quirke (1983), after careful evaluation of tillage methods, decided on an eleven point ripper plough to determine the wear resistance of currently employed materials, as such a tool has a simple shape and allows for relatively easy specimen preparation. Even so, this method was found to be inappropriate for precise wear testing, the main reason being the lack of reproducibility due to insufficient control over operating variables such as the geometric arrangement of the points, tilt adjustment, tyne alignment and soil compaction by tractor wheel tracks. Additionally, variations in point shape and size, and difficulties associated with their heat treatment, gave rise to inconsistent wear rates and ranking orders. This led to the development of a more controlled simulative rig test utilizing simplified tools, but at the same time incorporating the experience gathered from actual service tests, and enabled the compilation of a ranking table of possible tillage materials (Quirke 1987).

The field test rig was slightly modified for the purpose of the present study, namely the influence of different microstructures and soil variations on the wear resistance of one particular steel. A preliminary study was thus conducted to establish the feasibility of the field testing procedure. In addition, two laboratory tests thought likely to reproduce field test conditions were evaluated with respect to their differentiability and transferability.

MATERIALS AND HEAT TREATMENT

As the wear resistance of a steel increases with increasing carbon content (p. 9), the obvious choice for a test material was a high carbon steel - such as AISI O1, which is classified as an oil hardening heavy duty steel with good retention of cutting edge and minimal dimensional changes during hardening. A medium carbon steel, SS 10/200, was chosen as a reference material because it was readily available and allowed comparison with the work done by Quirke (1987). Compositions of these steels are given in Table 3.

Steel	C	Si	Mn	Cr	W	V
AISI O1	0.93	0.25	1.10	0.60	0.60	0.10
SS10/200	0.48	0.24	0.94	0.16	-	-

Table 3: Chemical composition of material tested in initial studies.

Heat treatment procedures are described in greater detail in the main experimental work and so are not repeated here. Of the specimens of the O1 steel ('test' material), one set was normalized (N), three sets were quenched and tempered (QT), and four sets were isothermally transformed (IT) according to the Time-Temperature-Transformation (TTT) curve supplied by the manufacturer. Heat treatments were carried out to achieve different microstructures and different hardnesses in the range 35-50 HRC, as this range had been determined most suitable for ripper points (Cooper 1986). The standard specimens were normalized to ensure a homogenous composition throughout. Table 4 lists the the resultant structures and some mechanical properties.

Test Set	HT	Structure Obtained	Hardness (HV30)	Charpy V Impact Energy (J)
S1	N	Pearlite	214	34
T2	N	Pearlite	344	9
T3	QT	Tempered Martensite	590	6
T4	QT	Tempered martensite	501	11
T5	QT	Tempered Martensite	438	17
T6	IT	Coarse Pearlite	273	14
T7	IT	Fine Pearlite	348	17
T8	IT	Upper Bainite	386	15
T9	IT	Lower Bainite	571	9

Table 4: Basic heat treatment (HT), microstructures and some mechanical properties of materials tested.

SIMULATIVE FIELD TEST RIG

The test rig (Fig. 23) consisted of a 2 m long section of square tubing mounted onto a tractor tool bar with a three point linkage. Attached to this frame were six equally spaced sleeves into which standard gauge (16 x 50 mm) flat bars of approximately 35 cm length could be fitted. The bars were adjusted to project 14 cm below the sleeves, and a 44 gallon drum, filled with stones, was used to weigh down the rig and ensure a constant soil penetration of 5-8 cm. A measuring wheel, capable of measuring the distance travelled to within 50 m, was also fitted to the frame in line with one of the tractor wheels.



Fig. 23: Field abrasion test rig.

The main advantage of using wear specimens made from rectangular bar and the vertical specimen geometry was the rapid development of a parabolic wear surface on the bottom of the bar, the shape of which remained roughly the same throughout the test. Little wear occurred at the sides of the specimen. This observation, in addition to the problems encountered with the accurate positioning and securing of

the bars to the sleeves, led to the substitution of the bars by specimen holders bolted into the sleeves. Smaller specimen tips, machined from flat bar, were then mounted to their ends by means of two Allen screws. Wear tips were marked individually so that they would always be refitted to the same positions on the rig. Dimensions of these specimen tips are given in Fig. 24.

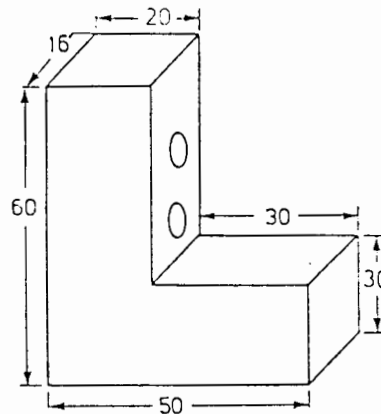

Fig. 24 : Dimensions (mm) of specimen tips machined for wear testing .

In addition to the smaller volume of material required for testing, this modification brought about the following advantages:

- (1) weight losses were realized over shorter distances and monitored far more accurately as the tips were lighter (250 g as opposed to 1.5 kg) and always projected the same amount from the sleeves;
- (2) smaller fields were required to obtain significant wear losses;
- (3) heat treatment of the tips was easier and resulted in more uniform properties;
- (4) speedy removal and refitting of the tips enabled a field test to be completed within one day, ensuring more consistent soil conditions (s.a. moisture content) during the course of testing.
- (5) For each test, four test specimens were run at the same time as two standard specimens, making the results statistically more reliable.

Pivoting motions of the test rig caused the wear rates of the two centre specimens to be marginally higher than those at the remaining four outside positions. The reference material was thus housed in the middle two positions and the material to be evaluated at either side of the standards. This arrangement further reduced any errors which might be brought about by the incorrect levelling of the rig.

Testing Procedure

Prior to testing, each specimen was thoroughly cleaned and weighed to within 0.01 g on a portable Mettler PC440 scale. After the specimens were mounted onto the rig, the horizontal and vertical tilt of the latter were adjusted by means of the alignment facilities on the tractor.

One complete field test consisted of five runs per test set, each over a distance of + 1 km at a constant speed of 7 km/h. After each run, the specimens were washed, dried and reweighed. Sets were tested consecutively (i.e. the second run only commenced after all sets had been run once) to ensure that all the specimens were subjected to similar soil conditions.

For every set, the mean cumulative volume losses and combined standard deviation were plotted against cumulative ploughing distance. The respective wear rates were determined from the slopes of the graphs through linear regression (Fig. 25). Correlation coefficients, all greater than 0.9938 (100% fit = 1.0) indicated that the spread of results was minimal. Relative wear resistances (wear rate of reference material/wear rate of test material) were corrected for the higher wear rates experienced by the center two positions on the test rig by taking into account the results of the set consisting of standards only (S1). Correction factors are given in Appendix 1. Results are listed in Table 5 and presented graphically in Fig. 27.

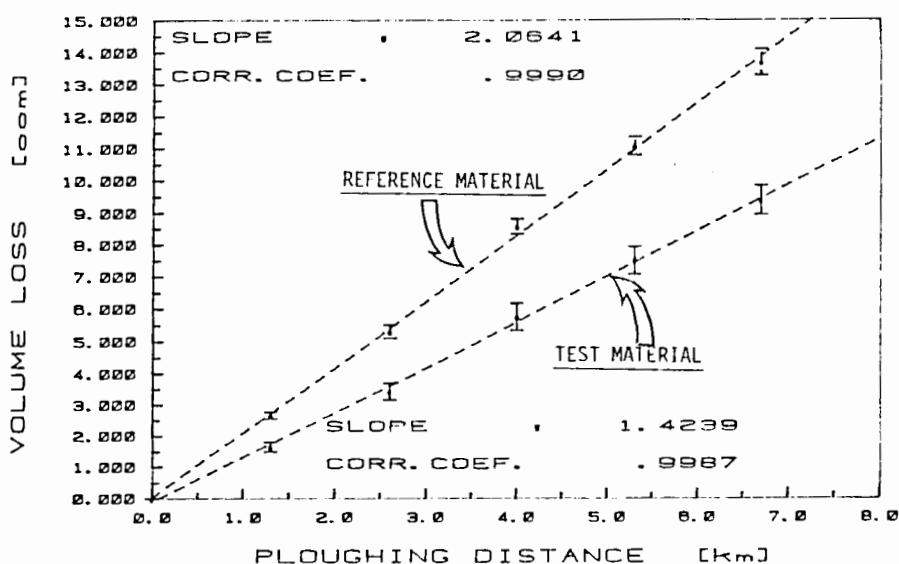

Fig. 25: Plot of volume loss vs. distance for a field test set.

LABORATORY TESTS

Examination of the wear surfaces of the field test specimen indicated that abrasive (high stress, minimal particle breakdown) and 'rubbing' (very high stress, particle degradation) mechanisms were be operative during the wear process, both of which could be simulated on a belt linisher abrasion tester. This equipment has been accredited with excellent reproducibility by Allen, Protheroe and Ball (1981) and is based on a modified Rockwell belt sander. A dead weight loaded 10mm x 10 mm specimen is abraded against a horizontally rotating abrasive belt, and can either be synchronized to travel across the belt or remain in the same wear track for the duration of the test (Fig. 26).

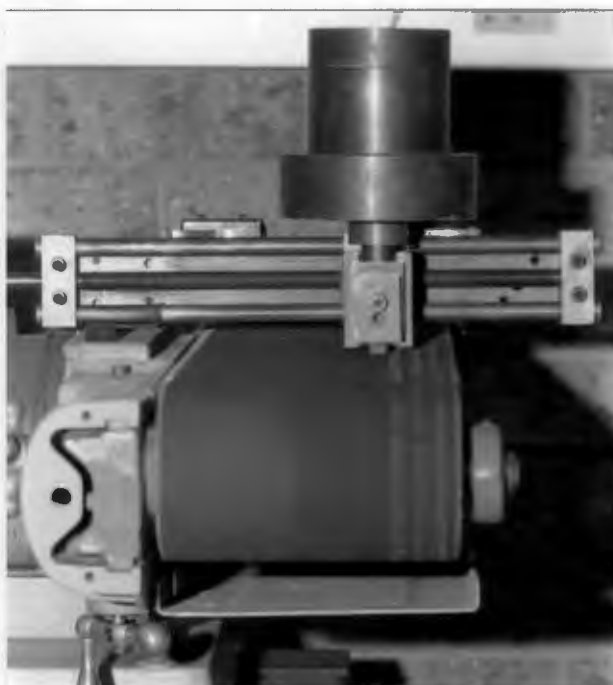

Fig. 26: General view of belt linisher abrasion tester.

A 40 grit alumina abrasive was chosen to represent the severe conditions encountered in the field of stoney and compacted soil. Loads were selected to duplicate the stresses experienced by the field test specimen, which nominally ranged between 510-715 kPa, depending on the weight of the rig. (In practice the stress levels are likely to be higher and variable due to the undulating motion of the specimens through the soil and impacting of stones.) The velocity of

the belt was kept constant at 0.4 m/s to prevent overheating and possible surface transformations of the small specimens.

Abrasion test

In this test, the specimen was transversed across the belt under a load of 5.95 kg (584 kPa) so that it was continuously abraded by fresh particles. Each sample was run in until the abraded surface was flat and uniform. The leading edge was marked so that in subsequent passes the sample was always aligned the same way. After running in, the sample was ultrasonically cleaned in alcohol and weighed on a scale with an accuracy of 0.01mg. One test entailed four passes, each of track length 366cm, between which the samples were again ultrasonically cleaned and weighed. Relative abrasion resistance was once again calculated by linear regression from the volume loss with distance.

Rubbing test

In this test, the specimen was subjected to a load of 15 kg (1472 kPa) and run in the same wear track over a distance of 340 m. The weight loss recorded was used to establish the relative wear resistance.

Results of both these tests are listed in Table 5 and represented graphically in Fig. 27.

Test set	RWR (field test)	RWR (abrasion test)	RWR (rubbing test)
S1	1.00	1.00	1.00
T2	1.40	1.24	1.10
T3	1.59	1.28	1.04
T4	1.53	1.24	1.21
T5	1.35	1.25	1.22
T6	1.30	1.13	1.25
T7	1.45	1.24	1.21
T8	1.51	1.27	1.35
T9	1.65	1.56	1.91

Table 5: Relative wear resistances determined in field and laboratory tests (relative to SS10/200, set S1).

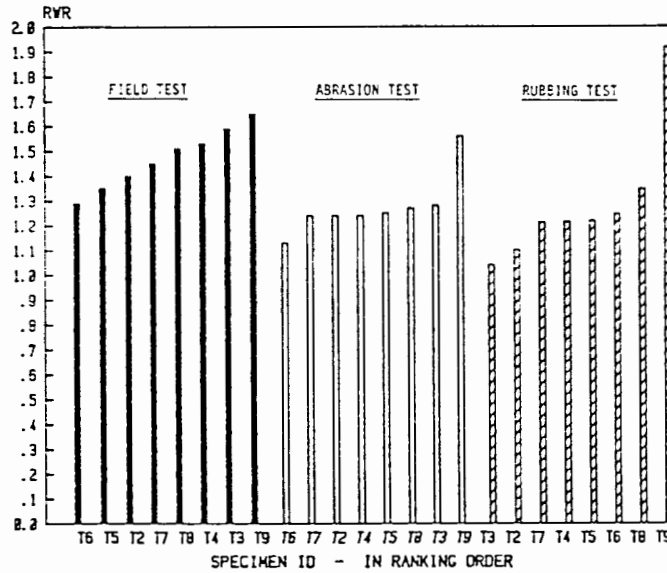

Fig. 27: Relative wear resistances obtained in field and laboratory tests. Specimen sets are arranged in their ranking orders for ease of comparison.

CONCLUSIONS FROM THE INITIAL STUDIES

Assessment of material

AISI O1 was selected primarily because of its high carbon content - to provide good wear resistance, and its ease of heat treatability. All the desired microstructures were obtained but, not surprisingly, contained sizeable particles of carbide. As discussed in the literature survey, secondary phases affect the wear mechanisms in numerous ways, and consequently present an additional factor in the tribosystem. Wear rates would thus be influenced to different extents in the various soils, and so blur any relationship between basic microstructure and soil properties.

The low impact energies indicated that the steel would be too brittle for use in practical tillage applications and probably fail catastrophically before wear-out could occur. Also, a maximum increase in wear resistance of only 65% over a normalized medium carbon steel did not encourage further testing of this material.

Assessment of simulative rig tests

The test rig was found to provide a simple means by which a large number of specimens could be tested in a short time. The disadvantage of machining test pieces was offset by simplified heat treatment methods, time savings during specimen changeover and more reliable results. Because of the small specimen size, wear loss per run was in the region of 8% of the specimen mass, significantly greater than the minimum of 0.1% stipulated by Moore (1986). The method successfully differentiated between the wear behaviour of the different microstructures and gave reproducible weight losses over the the distance tested, as augmented by the correlation coefficients. Variations per run were also within the 10% limit set by Moore (1986).

Assessment of laboratory tests

Results from the laboratory tests did not correlate with those of the field tests.

The abrasion tests bracketed some of the trends observed in the field tests, but did not give adequate differentiability to be conclusive. This may be attributed to the presence of carbides in the test material and the abrasive grit size used. Richardson (1967) had found a close resemblance between field tests and lab tests when using 40 grit abrasive, but Salesky and Thomas (1981) reported that the rate of wear was independent of particle size below 60 grit. Transferability between the rubbing test and the field test was non-existent. As the samples were continuously run on the same wear path, it is likely that they wore against an abrasive/debris mixture, which can lead to adhesive wear situations (McQueer 1985), and the test was abandoned.

In the light of the preliminary results and findings of the literature survey, it was decided to change the material to one of hypoeutectoid carbon content to prevent carbide formation so that the effect of microstructure per se could be evaluated.

As the belt linisher abrasion test represents high stress 'fixed abrasive' wear situations, it would be used in further testing, with the abrasive changed to 80 grit to eliminate the grit size effect. In addition, the standardised dry sand rubber wheel abrasion test was chosen to represent low stress abrasion under 'open' or 'loose abrasive' conditions.

CHAPTER 4

MAIN EXPERIMENTAL WORK

MATERIALS

The initial studies had shown that a hypoeutectoid steel would be better suited for the purpose of this investigation, and so SS10/83, a low alloy steel with a carbon content of between 0.6 - 0.75% was chosen. The steel was supplied as flat rolled bar by the United Steel Corporation of South Africa (USCO), together with its chemical analysis, which is presented in Table 6. SS10/200 was again used as the reference material.

<u>C</u>	<u>Si</u>	<u>Mn</u>	<u>S</u>	<u>P</u>	<u>Cr</u>	<u>Ni</u>	<u>Mo</u>	<u>Cu</u>	<u>Sn</u>	<u>Al</u>
.71	.31	.55	.026	.012	.28	.11	.03	.18	.024	.010

Table 6: Chemical composition of the test material, SS10/83.

SPECIMEN PREPARATION

In total, 96 test specimens and 54 standard specimens were machined according to the dimensions shown in Fig. 24. As the specimen orientation in the test rig differed to the one of actual rippers, Charpy test specimens were cut from the bar in both the longitudinal-transverse (L-T) and longitudinal-short (L-S) directions to allow determination of impact strength under test and real life conditions (Fig. 28). In addition, Hounsfield tensile specimens were machined to determine the ultimate tensile strength (UTS).

HEAT TREATMENT

In order to obtain different microstructures over a range of hardnesses the steel was either quenched, austempered or normalized. Obviously, the simplest (and hence least costly) hardening method is direct quenching to martensite with subsequent tempering to raise the toughness. Martempering was not considered advantageous as the

section thickness of rippers does not vary to any great extent, and besides being a more expensive and difficult procedure, also leads to greater amounts of retained austenite.

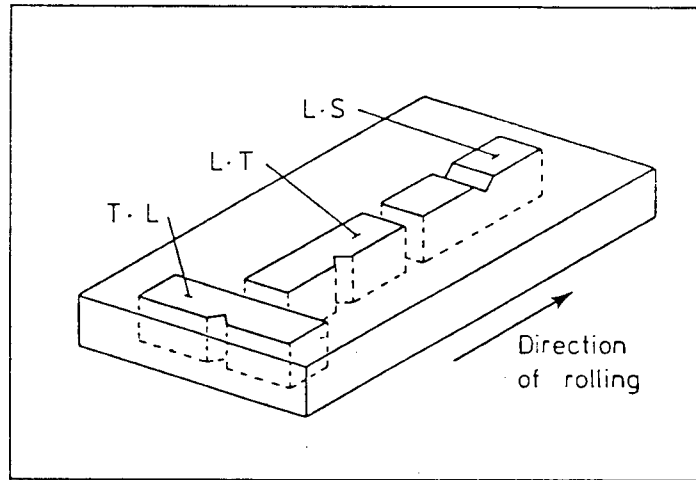

Fig. 28: The three possible ways of cutting Charpy specimens from a rolled bar for impact strength determination.

Pearlitic and bainitic structures achieved by austempering can be expected to have better toughness values (at similar hardness levels) than those attained by conventional hardening. Furthermore, no large or harmful stresses are induced in the tools and consequently distortion is minimized.

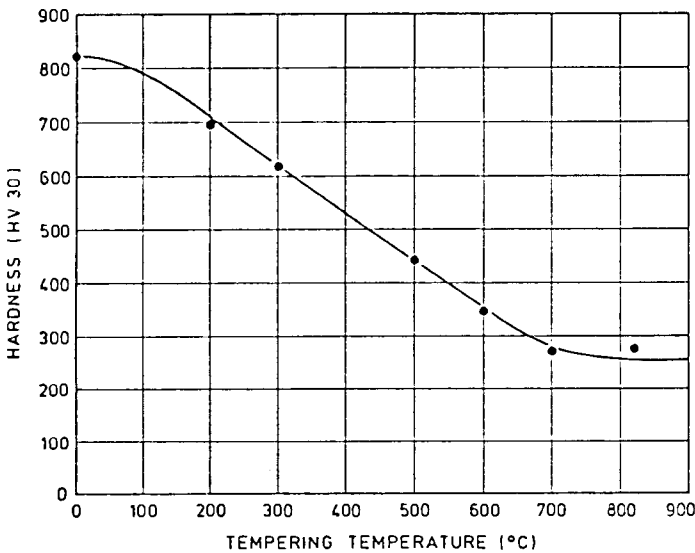

Fig. 29: Tempering curve for SS 10/83 determined from preliminary heat treatments.

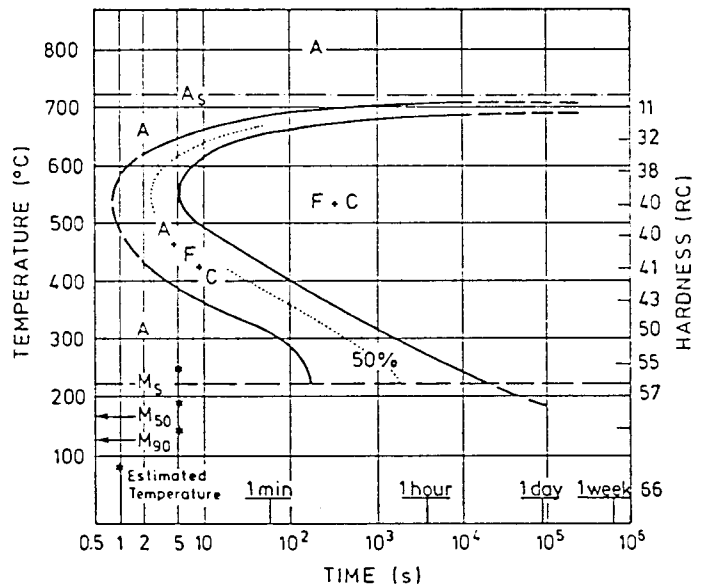

Fig. 30: TTT diagram for SAE 1080 steel used for isothermal transformations.

Unfortunately, no information other than the chemical composition of the steel was supplied. (Specimens were sent for testing on a high speed dilatometer at the CSIR, however, no TTT diagram could be obtained.) Both the tempering curve (Fig. 29) and the austempering parameters were thus determined from preliminary heat treatments using small (2 x 2 x 1.6 cm) specimen blocks. A TTT curve for a eutectoid carbon steel (SAE 1080, Fig. 30) was used to establish the temperatures and times required for isothermal transformations. For the latter heat treatments it was found necessary to raise the austenitization temperature from 820 °C to 850 °C to increase the amount of carbide dissolution (and hence hardenability), but still prevent excessive grain growth and higher amounts of retained austenite.

The test specimen tips were treated in batches of fours to ensure their uniformity. One 33 kW Naber laboratory furnace was used to preheat the tips to 650 °C over a period of 60 min to avoid possible cracking or warping and extensive heating times in the austenitization furnace. After preheating, the specimens were brought to the hardening temperature in a protective atmosphere of nitrogen gas in another Naber furnace, where carbon blocks were added to decrease decarburization even further. (It should be noted that for a 0.85% carbon steel heated in air for 1 hour at 900 °C the decarburized layer extends over only 0.54 mm, which would be removed in the first field test run). The effective holding time of 15-20 min after temperature equalization was sufficient to produce homogeneous austenite without noticeable increases in grain size.

Specimen tips for conventional hardening were quenched from 820 °C in oil and agitated vigorously to increase the cooling rate. Tempering was carried out immediately following the quenching operation to prevent cracking. Specimens to receive the same treatment were tempered simultaneously for 1 hour at the temperatures determined from the tempering curve.

Difficulties were experienced with the isothermal treatment of tips. The desired structures were not immediately obtained for two reasons: 1) the volume of the tips was far greater than the small specimens used in the preliminary heat treatment, and 2) the capacity of the nitrite salt baths (about 2 l) was not large enough to take up

the heat from the tools without appreciable temperature increases. Consequently, the temperature rises of the bath on introducing the charge, as well as the cooling rates of specimen centre and surface were measured for various salt bath temperatures by means of thermocouples inserted into a tip (Fig. 31). From these results the initial salt bath temperature required to bring about the desired transformation was estimated.

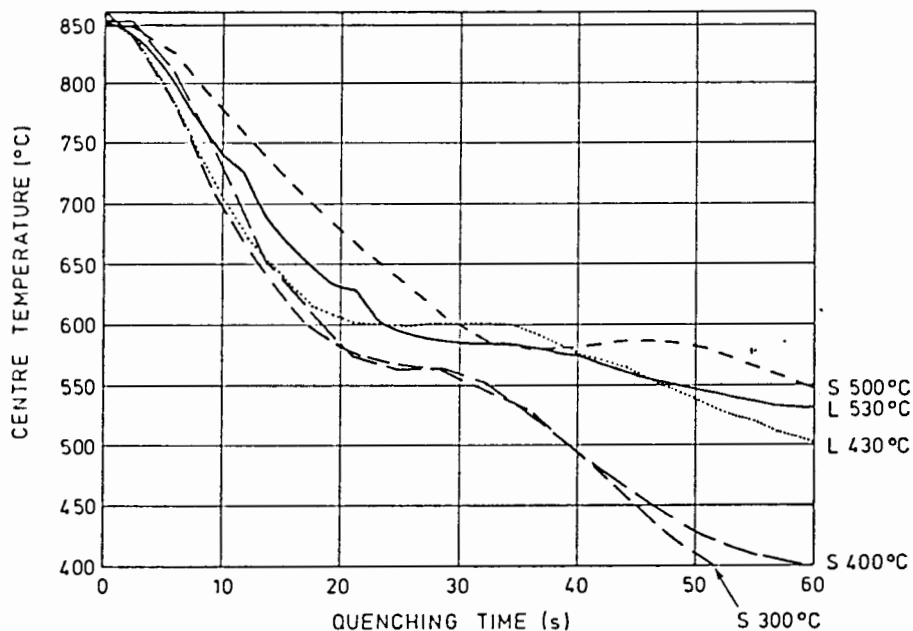

Fig. 31 : Cooling rates at specimen centre for various salt (S) and lead (L) bath temperatures. Differences between surface and centre temperatures were minimal.

The 54 SS10/200 and 4 SS10/83 specimens were normalized from a hardening temperature of 820 °C.

The final heat treatment schedule is listed in Table 7.

OPTICAL METALLOGRAPHY

Small samples were cut from the non-wearing region of specimen tips between and after heat treatments to establish whether transformation to the 'proper' microstructures had been achieved. Because minor structural variations were found to occur between surface and bulk, worn field test specimen were used for metallographic studies

to give a true reflection of the microstructures obtained. Tips were sectioned transversely, polished to 0.25 μ m and etched in 5% Nital. Micrographs were taken close to the abraded surface.

SET	AUSTENITISATION	TREATMENT
Std.	820 °C, 30 min	Normalized
1	820 °C, 30 min	Normalized
2	820 °C, 30 min	OQ, 320 °C 60 min
3	820 °C, 30 min	OQ, 400 °C 60 min
4	820 °C, 30 min	OQ, 500 °C 60 min
5	850 °C, 30 min	IT, (655 °C) 665 °C 80 sec
6	850 °C, 30 min	IT, (380 °C) 415 °C 30 sec
7	850 °C, 30 min	IT, (243 °C) 315 °C 15 min
8	850 °C, 30 min	IT, (190 °C) 250 °C 90 min

Table 7 : Final heat treatment schedule of specimen tips required for field testing. Values in brackets give initial salt bath temperature before introduction of charge.

MECHANICAL PROPERTIES

Vickers hardnesses of the sections prepared for optical metallography were measured on an Eseyway hardness tester with 30kg load. Tensile strength and % elongation were determined on a Zwick tensile testing machine, and impact strengths from Charpy V-notch specimens. Material properties are listed in Table 8.

Specimen	HV30	Impact Strength (J)		%elong.	UTS (MPa)
		L-T	L-S		
Std	152	122.2	196.4	37.3	466
1	275	13.7	16.1	20.9	1119
2	463	7.1	7.1	7.1	1718
3	374	13.5	15.9	14.9	1810
4	343	22.6	25.0	17.5	1432
5	266	15.7	16.1	20.2	954
6	361	22.1	23.2	16.8	1290
7	379	15.7	19.1	16.7	1589
8	557	7.4	4.4	7.6	1699

Table 8: Mechanical properties of the steel used for testing. (HV30 measurements averaged over three sections with five measurements each, all others are the mean of two tests.)

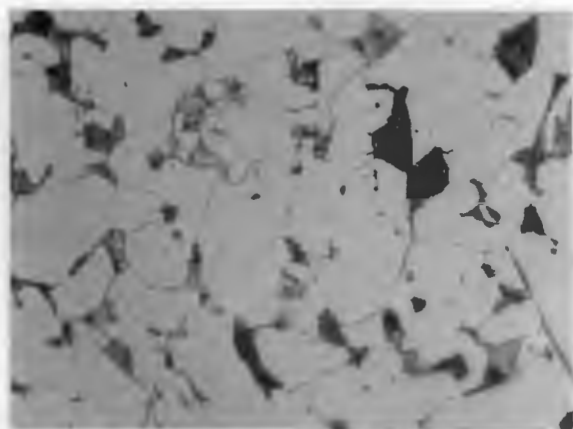

Fig. 32 : SS10/200, normalized. Proeutectoid ferrite and pearlite.



Fig. 33 : SS10/83, normalized. Proeutectoid ferrite and pearlite.

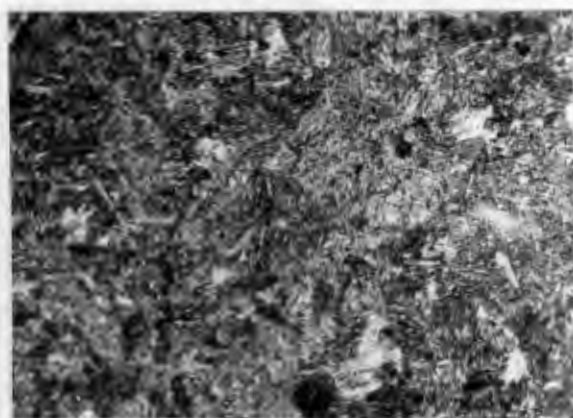

Fig. 34 : SS10/83, oil quenched, 320 °C temper. Tempered martensite.

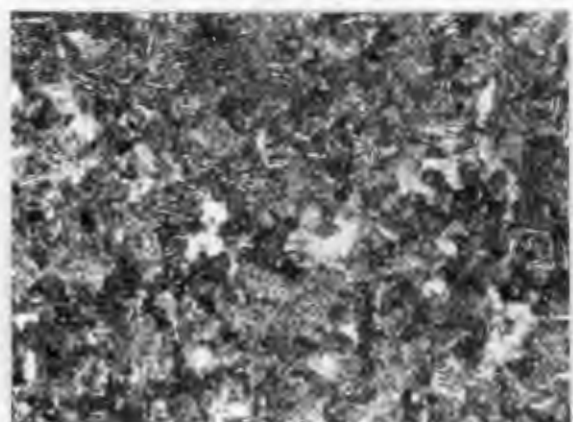

Fig. 35 : SS10/83, oil quenched, 400 °C temper. Tempered martensite.

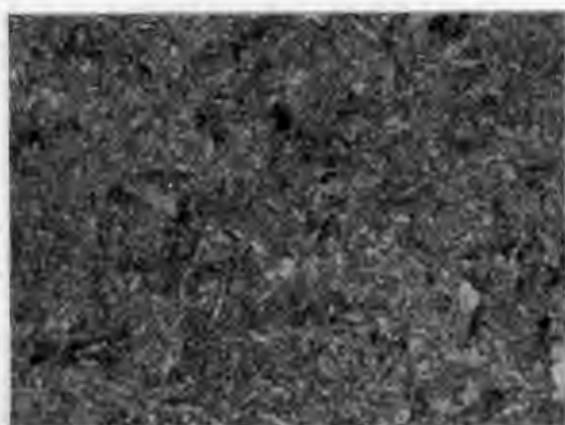

Fig. 36 : SS10/83, oil quenched, 500 °C temper. Tempered martensite.



Fig. 37 | SS10/83, IT, 665 °C, 80 s. Coarse pearlite.

20µm

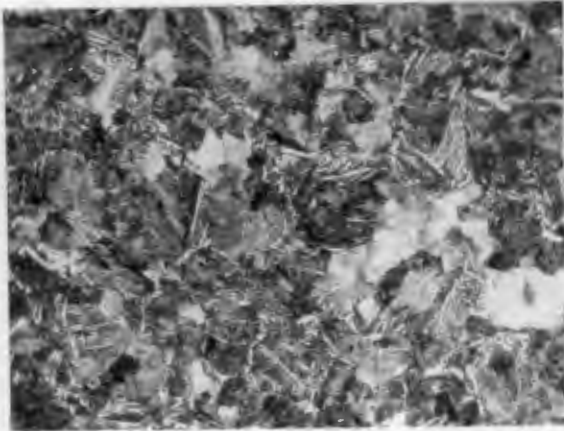

Fig. 38 : SS10/83. IT, 415 °C, 30 s. Fine pearlite, with regions appearing bainitic.

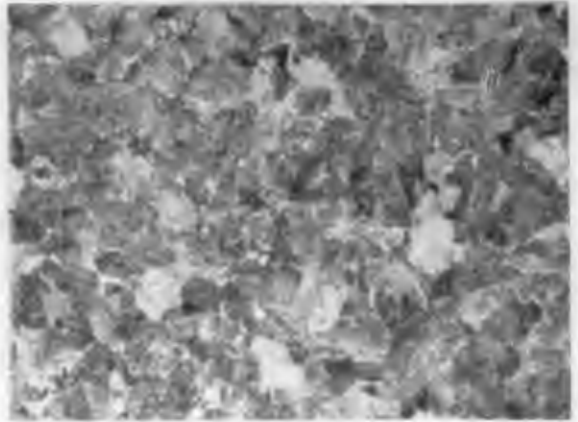

Fig. 39 : SS10/83. IT, 315 °C, 15 m. Upper bainite.

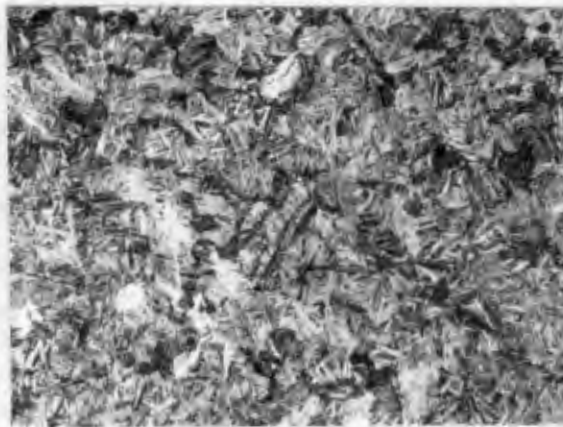

Fig. 40 : SS10/83. IT, 250 °C, 90 m. Lower bainite.

FIELD TESTS

Five field tests were conducted in various regions of the Western Cape, representative of stoney, sandy, and clayey soils. It was not always possible to find fields large enough to permit testing over unbroken land; such fields were crossploughed, with the necessary care taken to subject all the test sets to similar conditions. Moisture contents were determined from soil samples taken randomly over the whole field during the course of the day, and particle size fractions determined by the 'cone and quarter' method. Fractions were grouped as stones, granules, sand and clay according to standard textbooks on sedimentation. Relative wear resistance was calcu-

lated by linear regression analysis. (It must be noted that RWR values and ranking orders varied considerably when calculated by RWR/run or when the first run was taken into account.)

Stoney soil

Two test were performed in adjacent fields in the vicinity of Hermon (near Wellington), close to the field used for preliminary studies. The (somewhat overgrown) fields were situated on a light slope; the soil may be described as hard and compact, containing large stones ($d > 8\text{cm}$).

During the first test, weight losses were found to be excessive on one side of the rig; thus the alignment was re-adjusted after every run. This led to improbable results, especially in view of the outcome of the preliminary tests. Calculations showed the error between the two leftmost and rightmost points on the rig to be well over 35% and that acceptable variations in weight losses were only obtained after the fourth run. Furthermore, the first run gave unproportionally high values of RWR/run, which was attributed to the wearing-in of the tips. Consequently, the first run was disregarded in all the field tests, resulting in considerably higher correlation coefficients and decreases in % variation. In further field tests, the alignment was not altered once it had been carefully adjusted before the first run. Nevertheless, the results obtained showed considerable variations, making their interpretation rather difficult.

Sandy soil

Two tests were performed in soils of different composition. The first field (near Paarl) was very small and had to be crossploughed twice. Almost no stones were present, but stubble on the field necessitated the frequent lifting of the rig to ensure proper penetration.

Field 2 (near Atlantis) was situated on a hill and consisted of very loose, sandy soil with some stoney patches.

Clayey soil

One test was performed in clayey soil (near Stellenbosch). Specimen were run in on a small field and tested on a sloping field with some stoney patches.

Soil compositions and relative wear resistances for the respective fields are presented graphically on the next few pages. Also calculated were the average wear resistances over all the tests (Fig. 44), as well as the average weight losses of specimens in the various fields (Fig. 45). Numerical data can be found in Appendix 1. Attempts were made to find any possible relationships between RWR and material properties, but no useful trends could be established.

LABORATORY TESTS

Belt linisher tests

This test method has been described earlier (p. 55) and was selected to represent high-stress 'fixed abrasive' conditions. Results are given in Table 9 and presented graphically in Fig. 46. Test parameters are listed below.

Load on specimen:	58.4 N
Path length/run :	4.88 m
Abrasive type :	Corundum
Abrasive size :	80 Grit
Test velocity :	32.5 cm/s

Dry sand/rubber wheel test

A description of this method may be found in the literature survey under the section 'Testing Techniques' (p. 48). The test was selected to represent low-stress 'loose abrasive' conditions, and was performed on a 'Falex Friction and Wear Test Machine' which con-

formed to ASTM standard G 65-80 (Fig. 41). Test parameters were those for 'Procedure A' of this standard and are given below.

Force against specimen:	130 N
Wheel revolutions :	6000
Rotation speed :	200 rpm
Abrasive :	AFS 50-70 test sand
Sand flow :	310 g/min

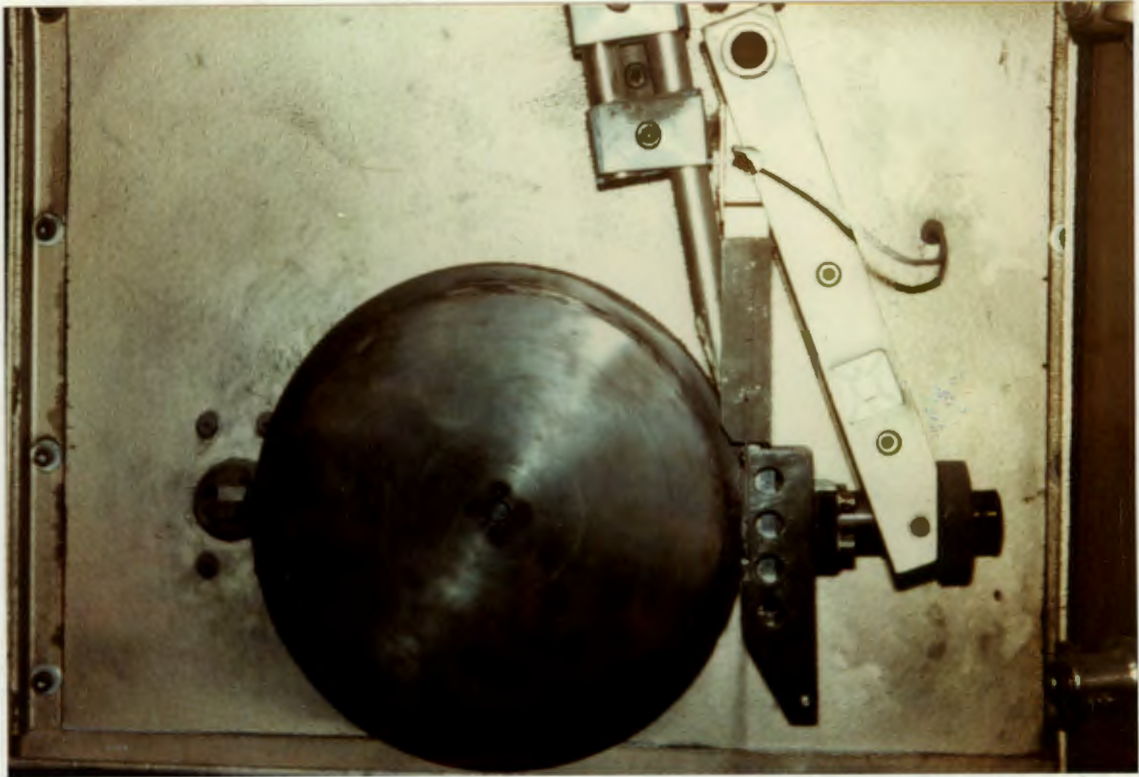

Fig. 41: Specimen configuration in the Dry Sand / Rubber Wheel abrasion test machine.

Specimens were prepared and heat treated separately from field test specimen; results from the austempering treatments were not satisfactory even though temperatures and times were adjusted for specimen size.

The rubber wheel deteriorated severely during the second run (old age and overheating) and the test had to be abandoned. RWR values were calculated from the first run, for the sake of completeness (Table 9).

Test Specimen	Belt Linisher Test		Rubber Wheel Test	
	HV30	RWR	HV30	RWR
S	174	1.00	242	1.00
1	286	1.37	260	1.69
2	648	1.72	618	2.13
3	550	1.57	514	1.85
4	422	1.46	415	1.39
5	266	1.31	287	1.69
6	370	1.45	283	1.72
7	520	1.64	312	1.59
8	666	1.90	326	1.49

Table 9: Hardness and RWR values for laboratory tests.

The results are presented graphically in Fig. 46. Some trends were observed when RWR values were plotted against hardness (Fig. 47).

STONEY SOIL
FIELD 1 & 2

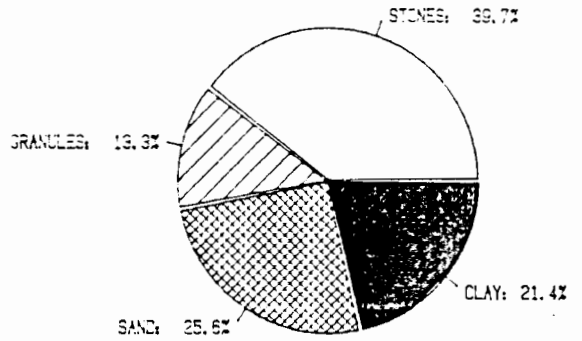
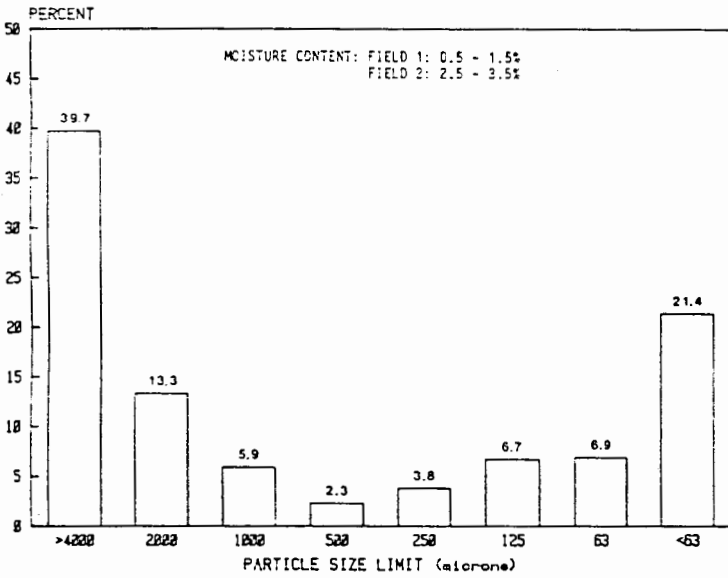

a.

SANDY SOIL
FIELD 1

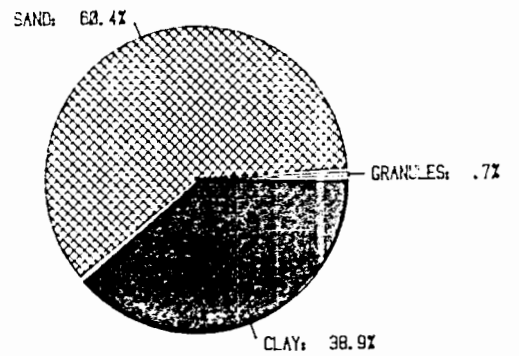
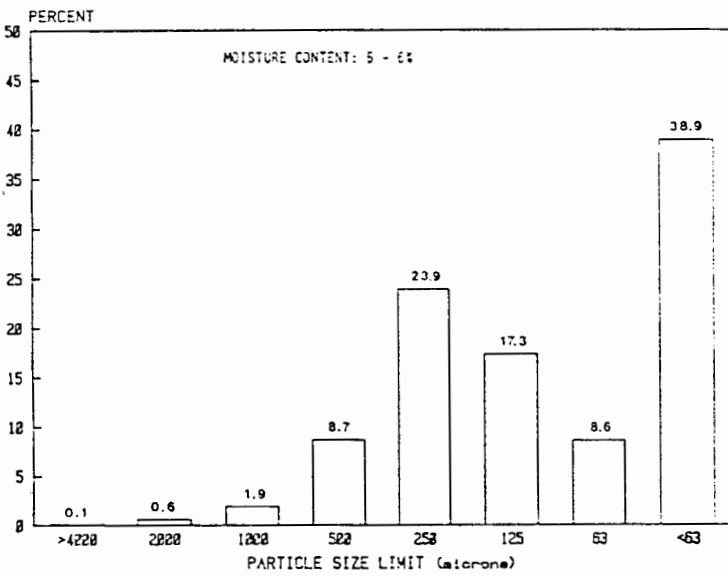

b.

Fig. 42 a - d: Soil compositions of the various fields used for testing.

SANDY SOIL
FIELD 2

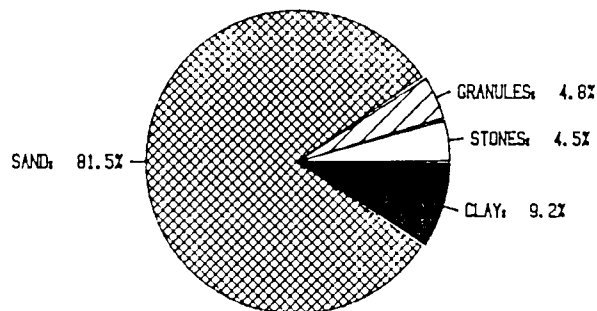
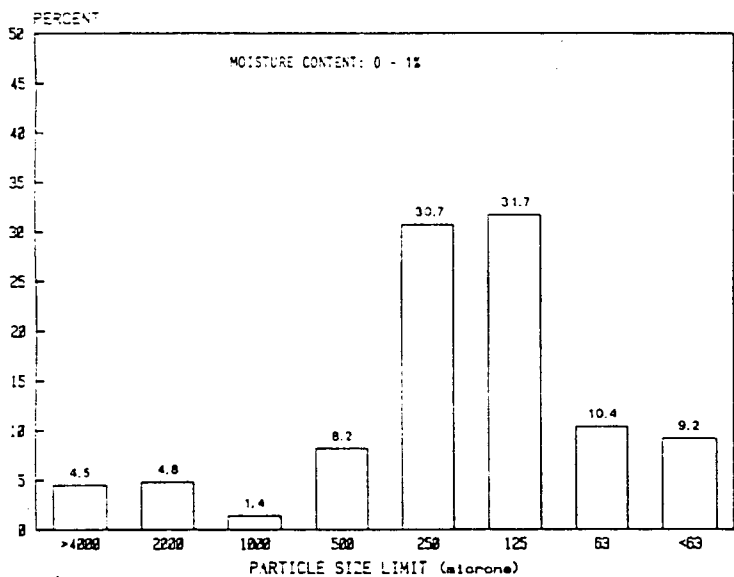

c.

CLAYEY SOIL

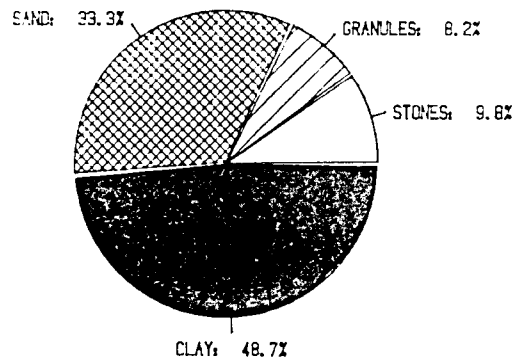
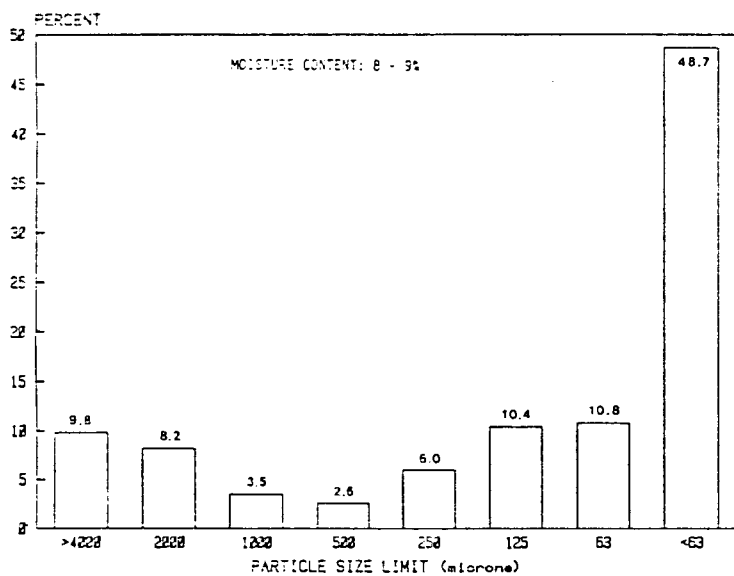

d.

Fig. 42 cont.

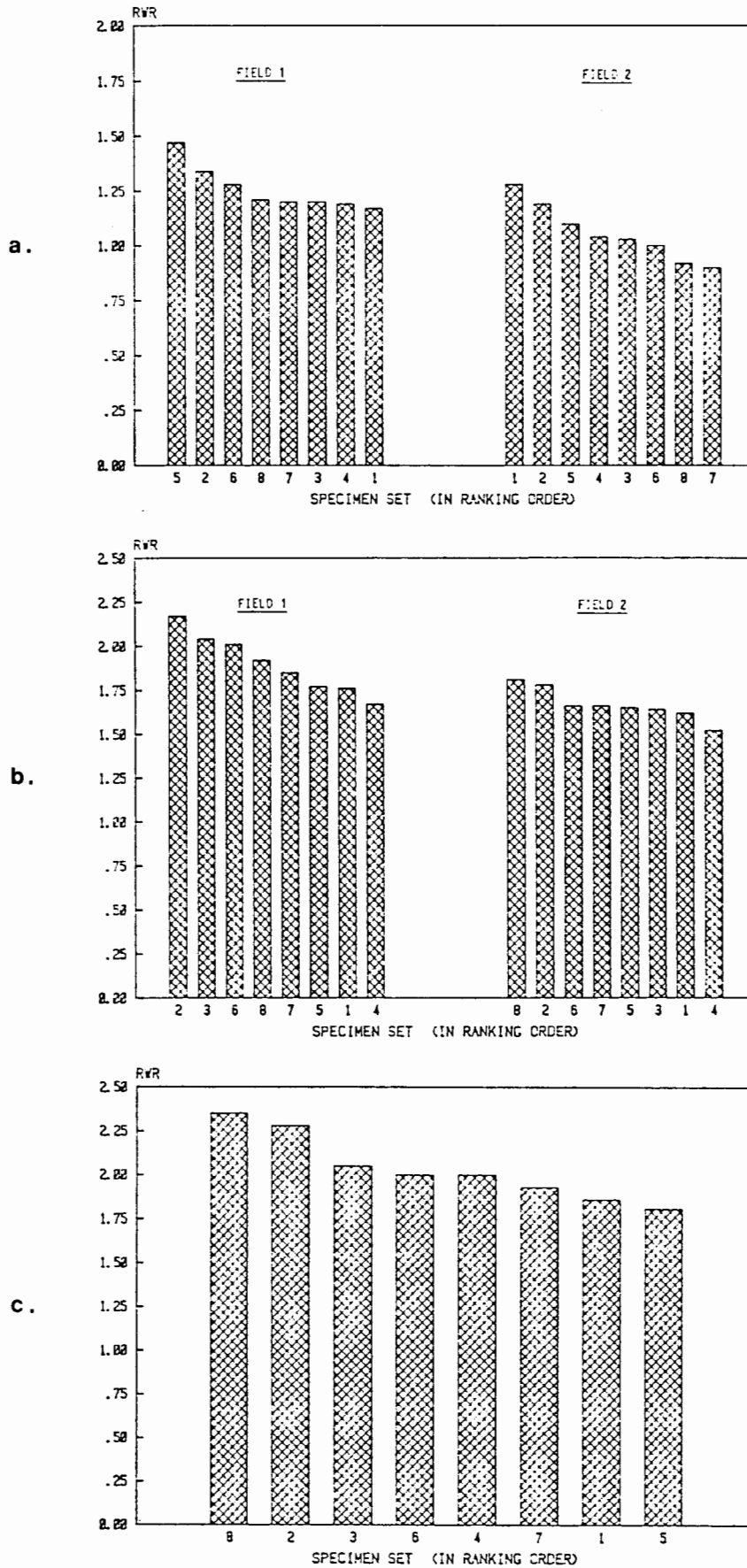

Fig. 43 a - c: Relative wear resistances determined in the field tests. Specimen sets are arranged in ranking order for ease of comparison. a) stony soil, b) sandy soil, c) clayey soil.

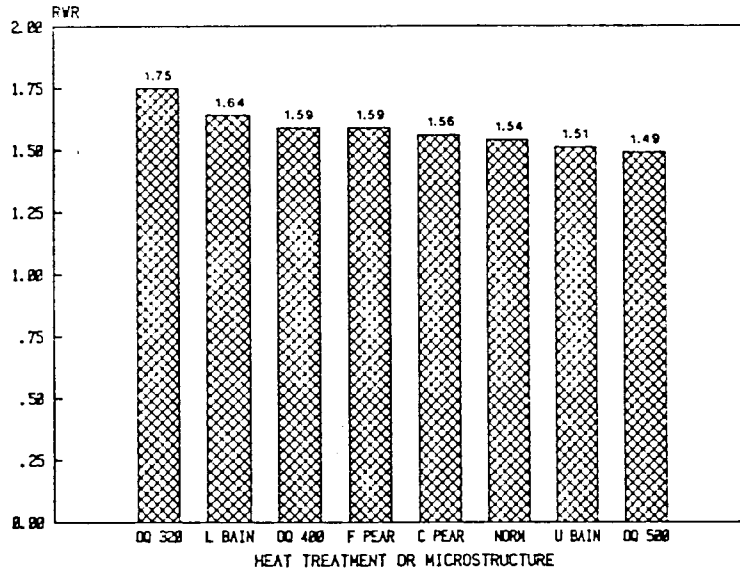

Fig. 44: Average relative wear resistance of specimens over all field tests.

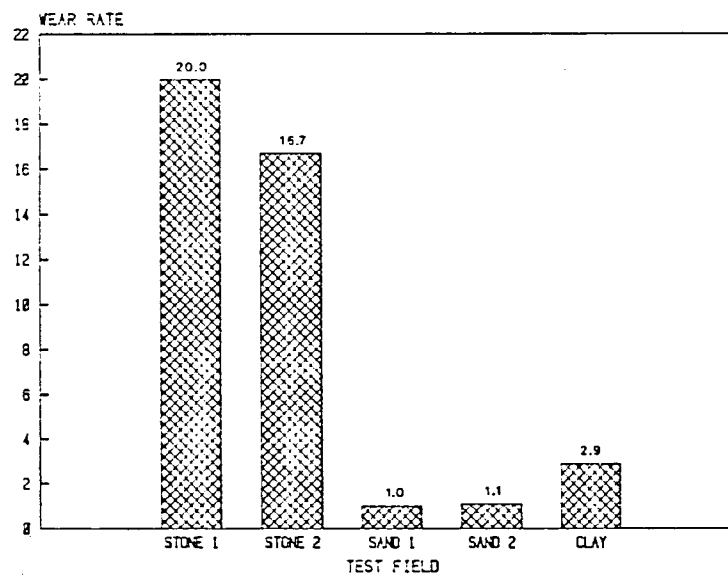

Fig. 45: Average wear rate (g/km) of all specimens in the various fields.

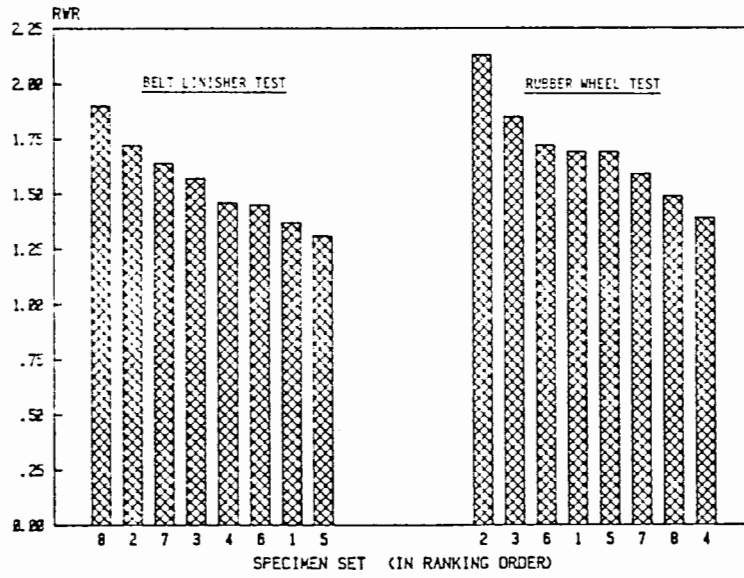

Fig. 46: Relative wear resistances determined from laboratory tests.

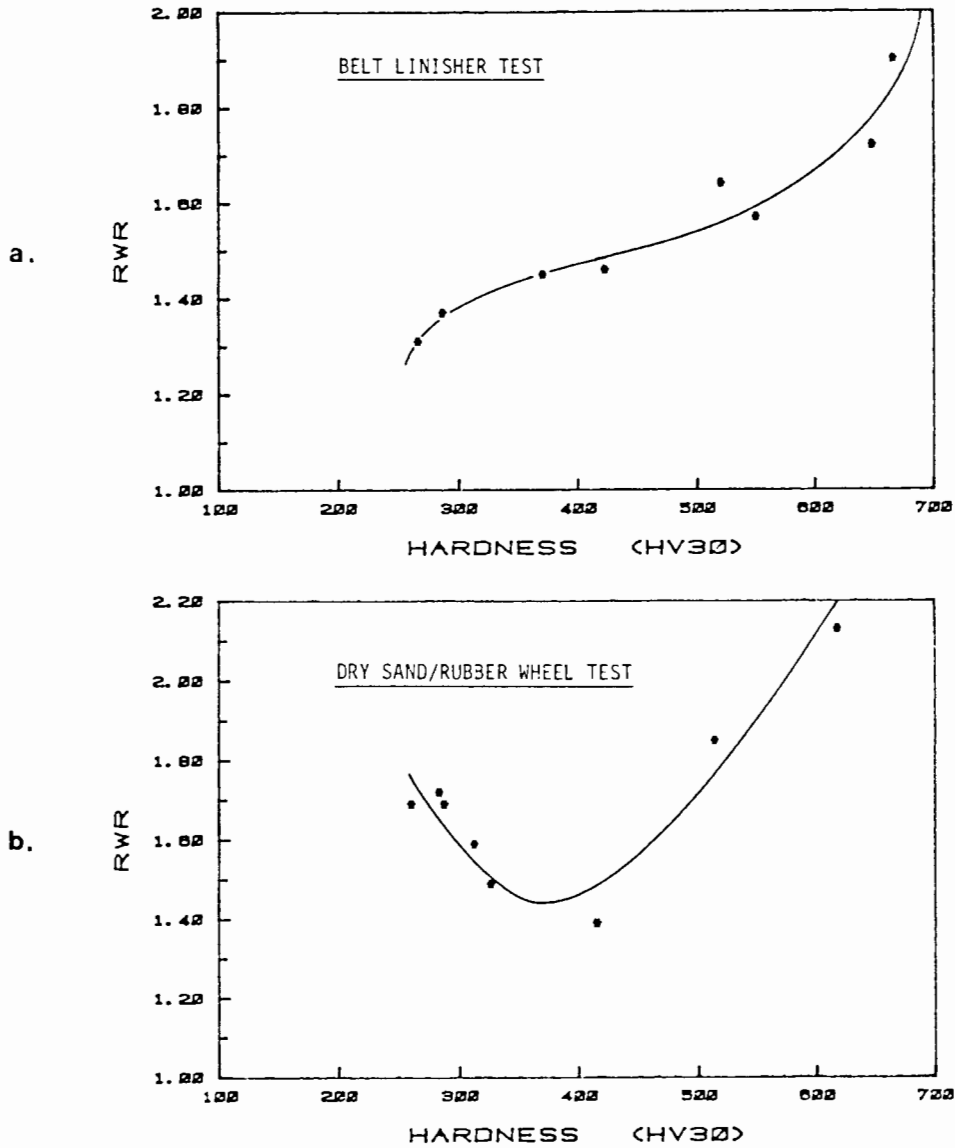

Fig. 47 a - b: Relative wear resistance vs. hardness for both laboratory tests.

ABRASIVE PARTICLE EXAMINATION

As abrasive wear processes are system specific, a study of this nature would be incomplete without the characterization of abrasive particle morphology.

Soils of the various fields were compared over the complete size spectrum, and their overall appearance classified according to angularity and the degree to which cutting facets were present (Table 10). Scanning electron micrographs (SEM) are included to illustrate the differences.

Field:	Stone	Sand 1	Sand 2	Clay
Angularity	++	+++	+	++
Facets	++	++	+	+++

Table 10: Soil particle angularity and the degree to which cutting facets were observed.

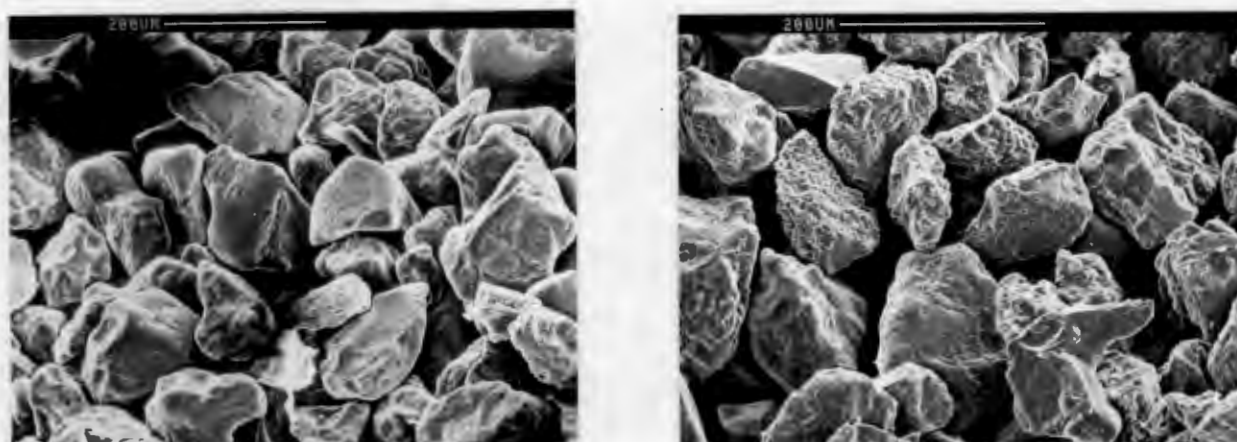

Fig. 48: 63 - 125 µm fraction of a) sandy soil, b) stoney soil. Particles are of similar shape, but the degree to which facets are present is far higher in stoney soil.



Fig. 49: Comparison of the abrasives used in the laboratory tests. a) AFS 50 - 70 testing sand, b) 80 grit corundum.

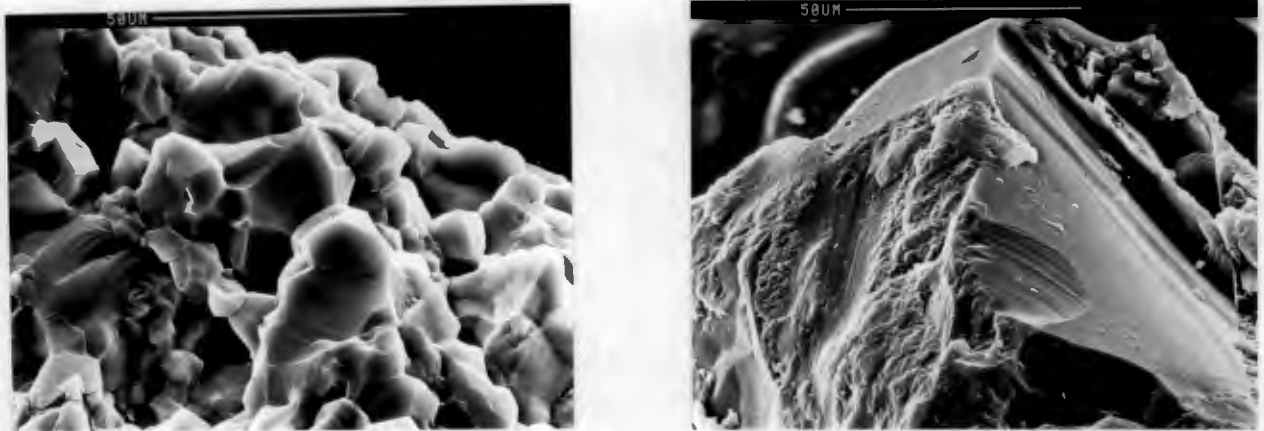

Fig. 50: Cutting facets. a) clay soil (125 - 250 μm fraction), b) 80 grit corundum.

SURFACE STUDIES

The wear surfaces of the specimens used in the field and laboratory tests were examined in the SEM to provide an indication of the prevailing wear mechanisms and the microstructural behaviour under different conditions. Microhardness measurements were carried out to determine the amount and extent of work-hardening of the surface layer. The white layers observed were examined in the SEM; attempts were made to prepare samples for transmission electron microscopy. X-ray diffraction was employed to establish whether structural changes had occurred during the wear process.

SEM examination of wear specimens

The degree of surface deformation was found to depend on the size and shape of the abrasive, the stresses the surface was subjected to, and the hardness (rather than the microstructure) of the specimens.

Whilst the entire spectrum of abrasive wear processes was observed for field-tested specimens, those present in the laboratory tests were more distinguishable, and are thus presented first.

Dry sand/rubber wheel abrasion test specimens

In general, the wear scars observed on the various specimens were extremely small, and seemed to be related to both material hardness and particle motion. Harder specimens exhibited very shallow wear grooves, caused by particle rolling (Fig. 51), whilst particle sliding resulted in the deeper grooves seen on the softer materials (Fig. 52). Microcracking and spalling were observed on all specimens in the region of particle exit (Fig. 53).

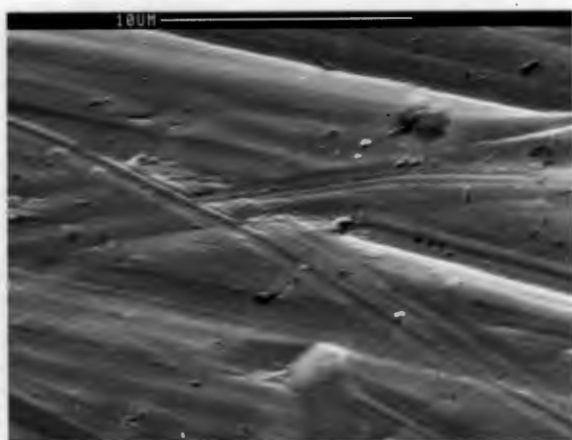

Fig. 51: Shallow wear grooves on the harder specimens, caused by particle rolling.

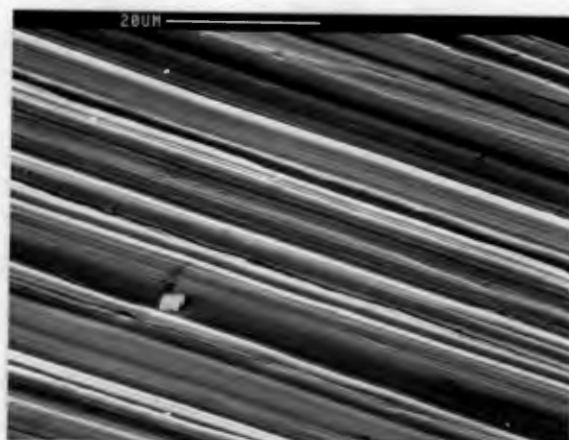

Fig. 52: Fine wear grooves on the softer specimens, caused by particle sliding.

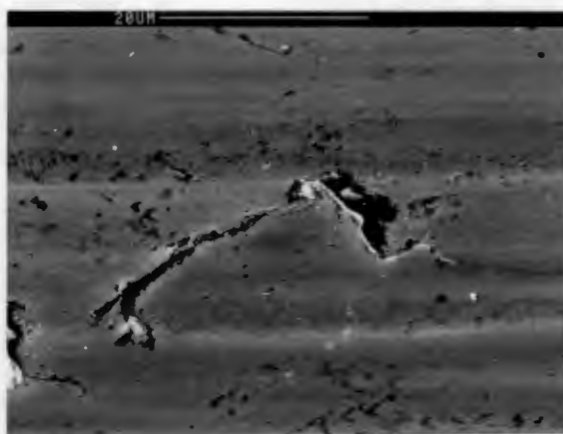

Fig. 53: Microcracking observed in the region of particle exit. Found on all specimens.

Belt linisher test specimens

The surface degradation in this test was found to be more severe than that displayed by the dry sand/rubber wheel abrasion test specimens; this can be ascribed to the angularity of the abrasive and its lack of mobility.

Material removal mechanisms varied between pure ploughing (Fig. 54) and pure cutting (Fig. 55), but a combination of the two was most frequently observed (Fig. 56). Fig. 57 shows the formation of secondary wear debris between two grooves, which may subsequently be removed by the action of other particles or, in softer materials, smear over the surface (Fig. 54).

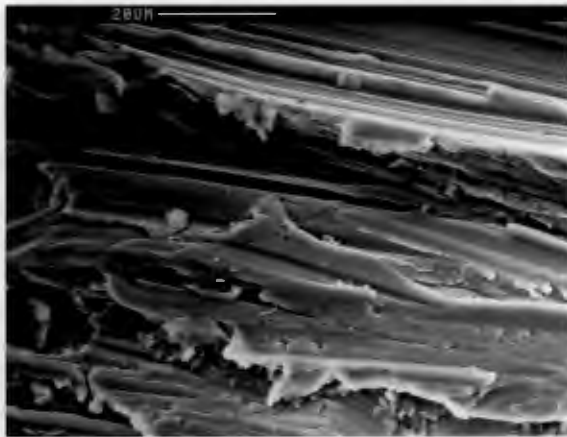

Fig. 54: Metal smearing observed on the normalized reference material.

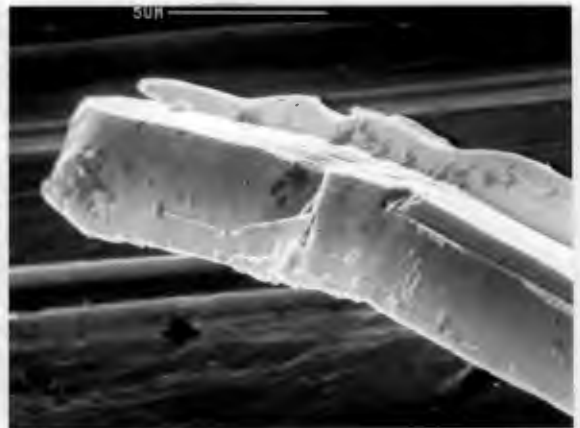

Fig. 55: Cutting wear debris from the hardest specimen used in this test (lower bainite). No plastic deformation is evident.

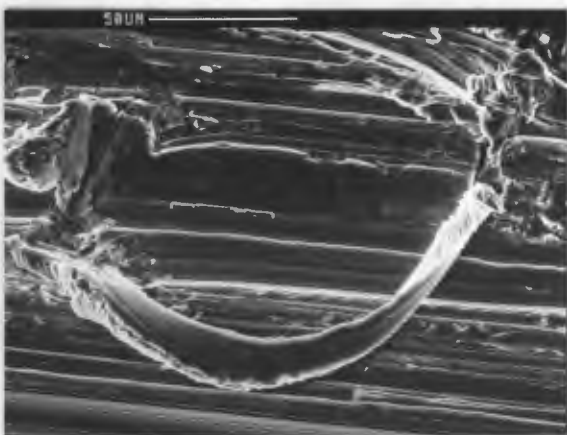

Fig. 56: Cutting wear debris dislodging from groove. Plastic deformation evident. (Tempered martensite).

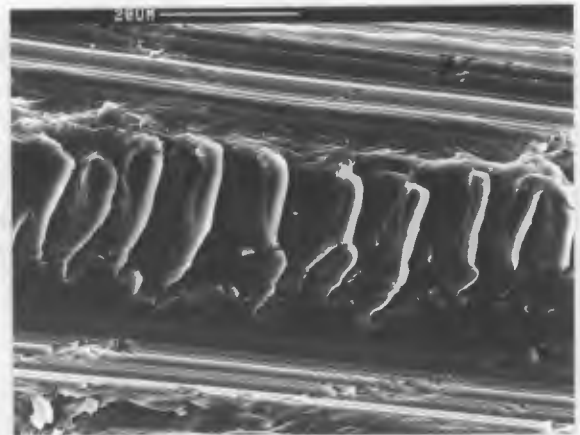

Fig. 57: Highly strained material between two wear grooves, giving rise to secondary wear debris. (Normalized SS10/83).

Abrasive particle fracture caused the regeneration of cutting facets (Fig. 58). In the softer specimens, such particles were often seen to be covered by material displaced from a subsequently formed ridge (Fig. 59).

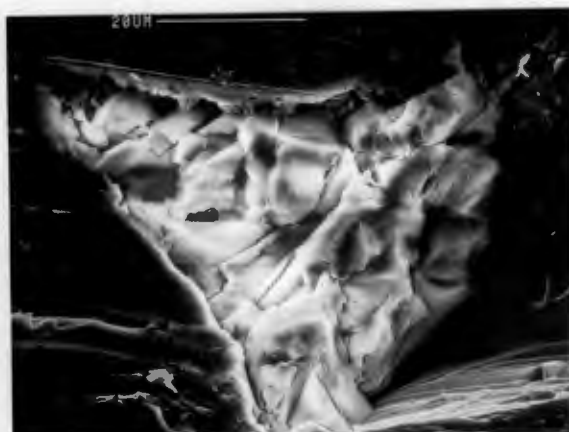

Fig. 58: Fractured particle embedded in surface causing regeneration of cutting facets. (Normalized SS10/83).

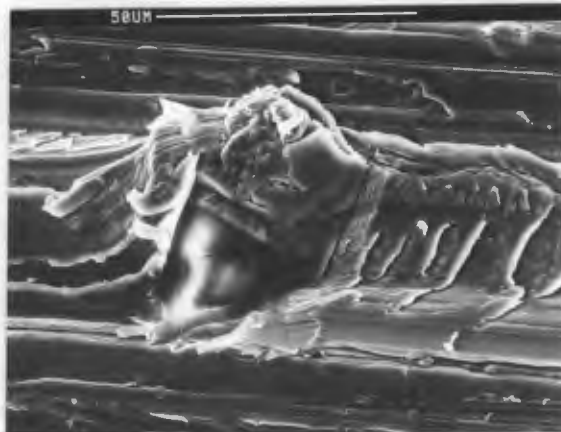

Fig. 59: Abrasive particle embedded in surface with metal from an adjoining ridge partly ploughed over it. (Coarse pearlite).

Field test specimens

Of the specimens used for wear testing, only those which had displayed the best performance (tempered martensite - OQ 320 °C, lower bainite, coarse pearlite), and those of low wear resistance (normalized structures) were investigated.

The surface damage observed in these samples corresponded with soil particle size and shape; larger particles causing deeper wear scars and hence higher volume losses.

The overall appearance of specimens tested in clayey soil was that depicted in Fig. 60. As the soil particle size increased, ploughing and cutting mechanisms became conspicuous (Fig. 61). The predominant wear mechanism of the harder materials was cutting, often accompanied by fracture (Fig. 62), but ploughing (Fig. 63), gouging (Fig. 64) and delamination (Fig. 65) were also observed.



Fig. 60: Normalized SS10/200, tested in clayey soil. Wear scars are extremely small and not present to any great extent (c.f. Fig. 53).

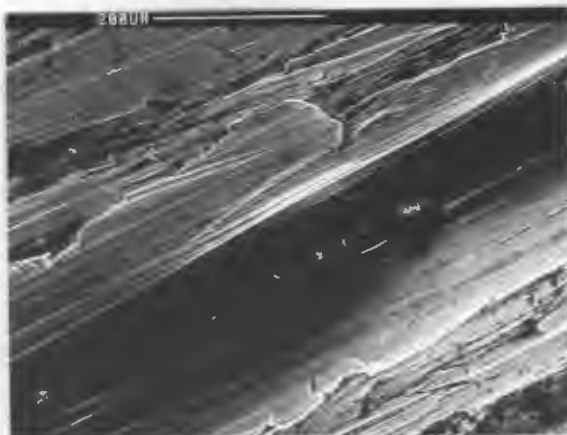

Fig. 61: Normalized SS10/200, tested in stoney soil. Large groove, ploughing mechanisms.

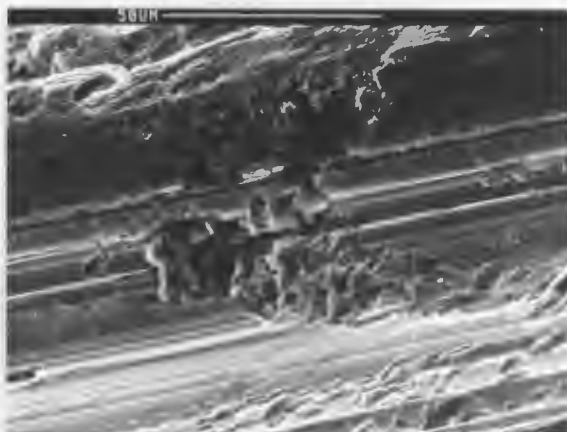

Fig. 62: Fracture inside a wear scar caused by cutting. (Tempered martensite, stoney soil).

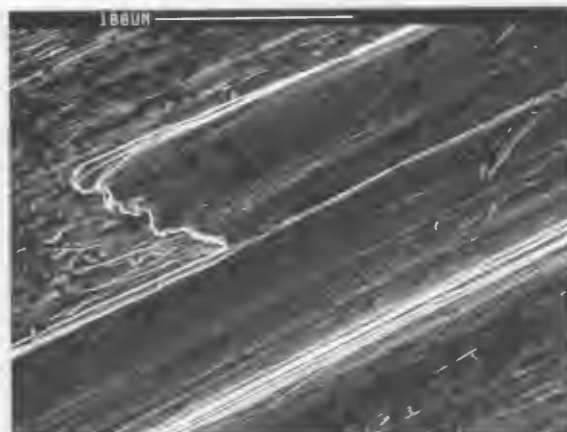

Fig. 63: Ridge of a plough groove which has been smeared onto the surface. The area in the top left corner was typical of specimens abraded in sandy soil (tempered martensite).

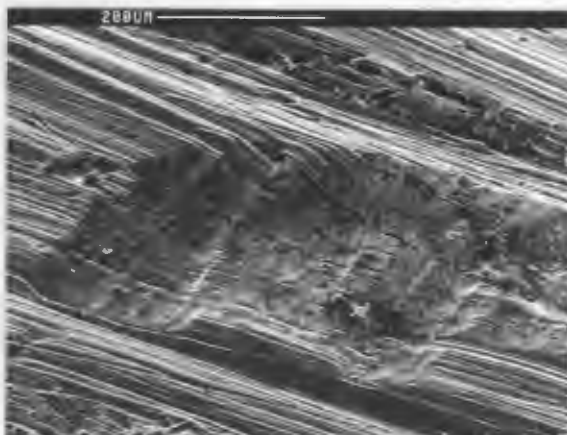

Fig. 64: Gouging wear, accompanied by fracture. (Tempered martensite, stoney soil).

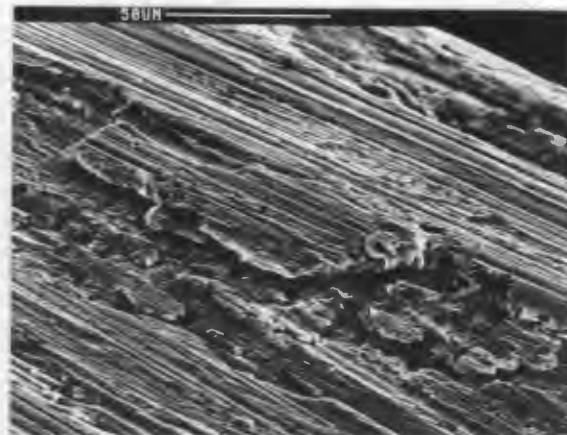

Fig. 65: Delamination. This feature was observed on all specimens, in all soils.

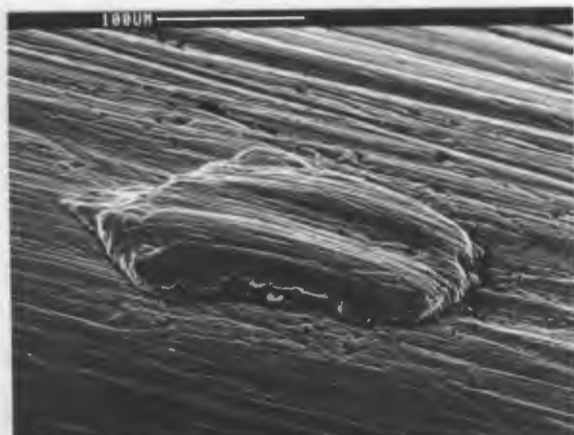

Fig. 66: Metal smeared over an embedded particle, subsequently worn by other particles (coarse pearlite, clayey soil, c.f. Fig. 59).

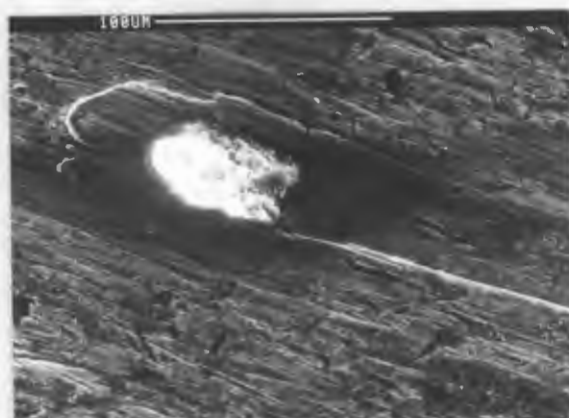

Fig. 67: Particle which has ploughed through the surface (coarse pearlite), but where ridges are worn away by sand particles.

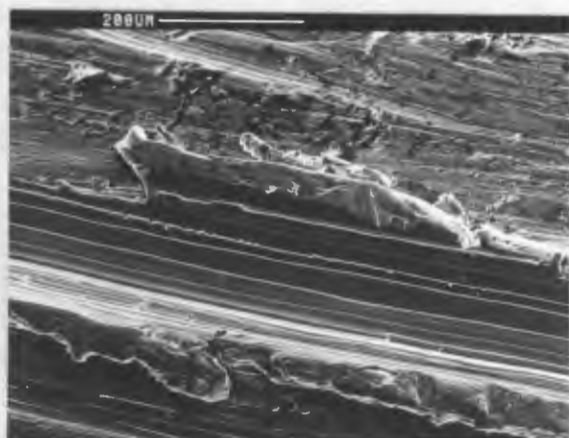

Fig. 68: Mixed mode of groove formation. The centre of the groove is cut, whereas the ridges indicate some degree of ploughing. (Coarse pearlite, stoney soil).



Fig. 69: Wear debris found during field tests (stoney soil, from reference material).

Microhardness tests

The surface examination showed that the specimen tips abraded in stoney soils had suffered the most severe deformation. It was thus convenient to use the samples which had been prepared for optical metallography (p. 62) for this investigation.

Numerous Vickers microhardness tests were performed on the extreme surface region. The measured values fluctuated considerably over a distance of 200 μm from the surface, whereafter the bulk hardness was attained. It was felt that no purpose would be served by presenting (rather confusing) scatter plots, and thus the general trends these curves followed are shown schematically in Fig. 70. Surface hardnesses for lower bainite (8), martensite tempered at 320 $^{\circ}\text{C}$ (2) and martensite tempered at 400 $^{\circ}\text{C}$ (3) were lower than the respective bulk hardnesses. Surface hardening was evident in martensite tempered at 500 $^{\circ}\text{C}$ (4), upper bainite (7) and the normalised specimen (1). The pearlites (5 & 6) showed variations of ± 30 HV0.05 from the bulk structure over this region.

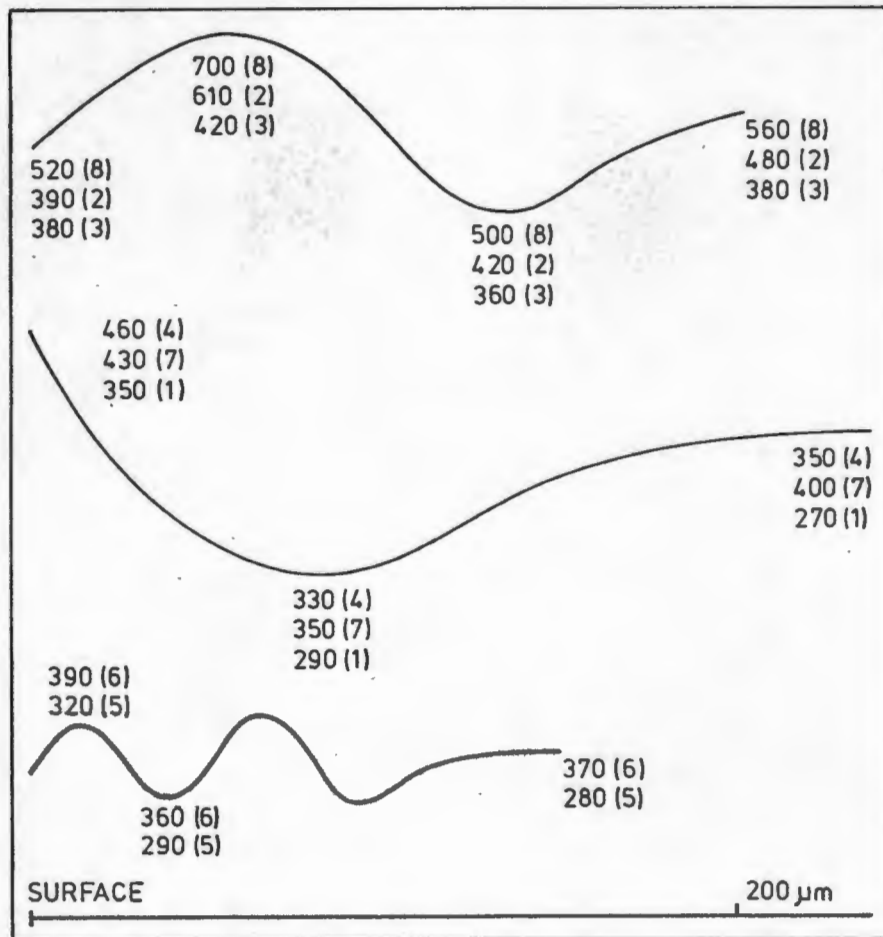

Fig. 70: General trends of microhardness measurements. Figures indicate the hardnesses (HV0.05) of the specimens - in brackets - at the respective point on the curve. For a fuller explanation see text.

White layers

White layers had formed on all the specimens used for field testing, but the extent to which they were observed was found to increase with the carbon content of the steel. Specimens machined from AISI O1 steel were thus sectioned transversely and Ni-plated to ensure edge retention during the polishing process. After the presence of these non-etching layers had been confirmed (by a nital etch), samples were examined in the SEM. The thickness of the layers was variable, but rarely exceeded 50 μm (Fig. 71). Large strains were not a necessary condition for their formation; layers were observed in regions which showed no deformation of the subsurface.

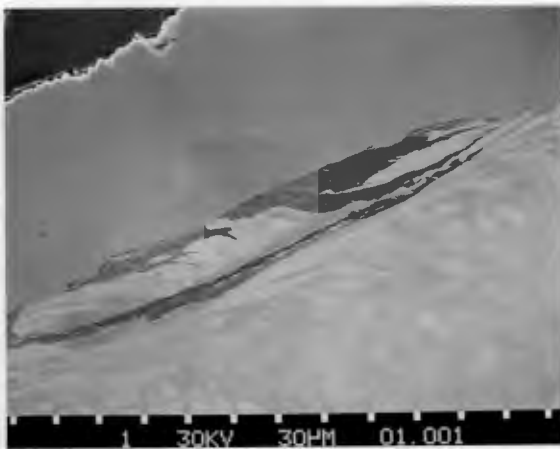

Fig. 71: A white layer observed on a nickel-plated AISI O1 specimen.

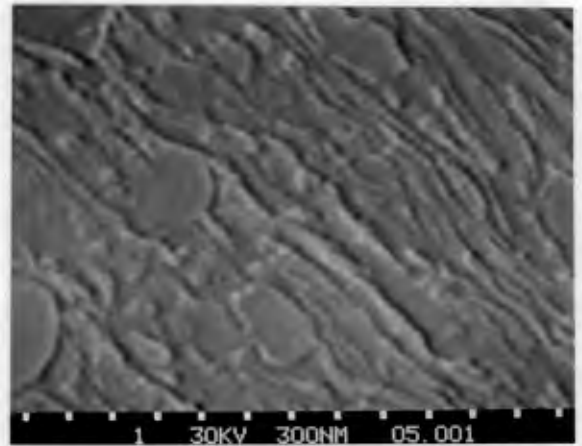

Fig. 72: High magnification micrograph (x 30 000) of white layer showing the presence of carbides.

Their structure appeared to be homogenous and fine grained; irrespective of the bulk microstructure, hardnesses were found to lie between 700 and 1200 HV30. The transition from the transformed area to the bulk structure could be gradual (over 20 μm) or occur over a few microns. Examination under high magnification revealed the presence of carbides, although these were far smaller and fewer than observed in the bulk (Fig. 72).

Attempts were made to prepare transmission electron microscopy samples for a closer inspection and electron diffraction studies. After a thick Ni-coating (2 mm) had been applied, a thin slice containing white layers was spark eroded from the specimen, and a 3 mm disc cut from the steel-Ni interface (again using the spark eroder). The nickel, however, tended to flake off during mechanical or electro-

jet polishing. No white layers were seen on the specimens which could be examined in the TEM; apart from this, the mass of the 3 mm disc caused beam bending. Sample preparation using the window technique did not yield any promising results either.

The temper colour of the wear debris collected during field testing (Fig. 69) suggested that considerable temperatures could be reached at the surfaces of the test specimens - hence X-ray diffractometry was selected as a means to investigate the possibility of austenite formation. SS10/83 specimen-sections (used previously) were analysed in a Philips diffractometer using a Mo X-ray tube and a Zr filter. (Details of this procedure may be found in the Philips scientific report 'The determination of retained austenite in steel by quantitative x-ray diffraction'.) Only the (200) α -martensite diffraction line was seen when the polished surface (bulk) and the side of the specimen (directly above the worn surface) were analysed. The worn surface, in all specimens, caused both a (200) α -martensite and a small (220) austenite reflection to appear. The area under the (220) diffraction peak was, however, too small to allow quantitative analysis.

CHAPTER 5

DISCUSSION

The primary objective of this work was to find the relationship between steel microstructure and abrasive wear in South African soils, such that the correct selection and heat treatment of materials can be made by the agricultural industry, and in doing so, bring about significant savings.

In the literature survey it was attempted to separate the various factors contributing to the abrasive wear of tillage tools, such as abrasive particle shape, particle size, soil moisture content or soil compaction. It is beyond the scope of this work to evaluate all of these factors in isolation and to determine their interdependence with respect to the series of field tests conducted. The following discussion is centred around the objectives and the information gained through field and laboratory testing.

A fundamental part of this study was the transformation of SS10/83 steel to different microstructures, and the degree to which this aim has been achieved will be discussed first.

MICROSTRUCTURES

The TTT-diagram for a eutectoid steel (Fig. 30, p. 60) stipulates that cooling to below 500 °C must be accomplished in less than 1 second to avoid the nose of the curve, and thus prevent the transformation to pearlite during cooling. The cooling curves for the different salt bath temperatures (Fig. 31, p. 62) however, showed that such high cooling rates were not obtained in the specimens, and that quenching was furthermore retarded due to the evolution of the latent heat of transformation, which could not be effectively dissipated in the small capacity salt baths. These observations indicated that mixed transformation products could be expected for the isothermal heat treatments; it also showed that comparisons of

mechanical properties should be exercised with care, as the smaller diameters and volumes of the Charpy and Hounsfield specimens would cause faster cooling.

The 'normalized' and 'coarse pearlite' structures exhibited very similar microstructures and mechanical properties, the latter structure having a slightly smaller interlamellar spacing between the ferrite and pearlite as a result of the faster cooling rate attained in the salt bath quench. The coarseness of pearlite decreases with a fall in transformation temperatures, and it is evident from the optical micrographs that the transformation to 'fine pearlite' was performed at temperatures low enough to have caused the separation of minor amounts of bainite along with the pearlite. More important, however, is the fact that the interlamellar spacing in this structure was significantly reduced with respect to the 'normalized' and 'coarse pearlite' specimens. This is also confirmed by a comparison of the mechanical properties: 'fine pearlite' is harder and has higher impact and fracture strengths, the reason being that the soft ferrite is more effectively constrained between the closely spaced, hard cementite lamellae, and cannot deform plastically to the same extent as in the coarser structures.

Although the formation mechanisms of fine pearlite and 'upper' bainite are different - in bainite the ferrite is thought to nucleate first at the grain boundaries - their structures are similar: both consist of ferrite platelets in juxtaposition with cementite platelets. As the temperature falls, bainite starts to form inside the grains as well; at the same time, the mode of formation changes. The resultant 'lower' bainite is acicular in appearance and contains a fine dispersion of epsilon-carbide (of higher carbon content than cementite), raising its hardness and toughness above that of 'upper' bainite. These differences in structural appearance were clearly observed during the metallographic examination, but it appeared that some martensite might be present in the 'lower' bainite.

A comparison of the initial salt bath temperature (190 °C) and the calculated M_S temperature for this steel indicate that martensite formation may have occurred. (According to empirical equations (K.E. Thelning: Steel and its heat treatment), the M_S temperature is given by $M_S = 561 - 474C - 33Mn - 17Ni - 21Mo$, which for this steel

yields a M_s temperature of 200 °C.) The low impact strength values for this structure are probably a result of considerable martensite formation in the smaller Charpy specimens.

The optical micrographs and mechanical properties of the quenched and tempered specimens indicate that oil quenching provided sufficiently high cooling rates for the massive transformation to martensite to occur. On tempering, the stresses caused by this shear transformation were relieved and resulted in improvements of the mechanical properties.

Structurally, epsilon-carbide ($Fe_{2.4}C$) precipitates at 80 - 100 °C and reduces the carbon content of the remaining martensite, causing the latter to be tougher and less brittle. Cementite (Fe_3C) starts forming at the expense of epsilon carbide at temperatures above 160 °C. As the temperature is raised above 400 °C, cementite growth and spheroidization cause the particle size and interparticle distances to increase, leading to considerable reductions in hardness. The carbides formed at high temperatures are, however, thermodynamically more stable.

It is likely that 500 °C temper embrittlement has occurred in the specimens treated at this temperature, even though the impact strength may at first suggest otherwise. In this temperature range, the degree of embrittlement depends on the cooling rate: slow cooling results in the deterioration of impact strength. Again, the smaller Charpy specimens would have cooled down faster, and would thus not have been affected to the same extent.

In summary, the microstructures obtained show some degree of mixed transformation. Nevertheless, the major phase present can be clearly distinguished as pearlite, bainite or martensite with varying particle spacing.

FIELD TESTS

In these tests, the coefficients of variation (ratio of standard deviation to sample mean; also referred to as '% variation of RWR/run' in this work) give an indication of the reproducibility of results. These coefficients may be considered relatively high in some in-

stances, and so the wear resistances and ranking orders should not be regarded as absolute, but should serve to identify factors of importance in the abrasive processes occurring in the different soils. Abrasive particle size, angularity, moisture content and wear mechanisms are interdependent, and are thus discussed in relation to the various soils.

Clayey soil. Due to the plasticity of this soil, the fine, angular particles are held relatively firmly and resist the movement of the tool; the characteristic particle motion is thus one of rubbing. The sharp particles tend to indent the surface and cause material loss by a ploughing or cutting mechanism, depending on the hardness of the metal.

The ranking order of the specimens confirms that, in this soil, the wear resistance of the material is governed by the hardness of the steel, and that microstructural parameters are of secondary importance. Lower bainite and martensite tempered at 320 °C perform best, while the soft, coarse structured pearlites show the highest wear rates. The ranking order correlates well with both the bulk hardness and the surface hardness determined from microhardness measurements.

Sandy soils. Here the mode of particle displacement changes, and with it the wear mechanism. Sand particles are less ellipsoid in shape and tend to become dissociated as the cohesive forces between them are diminished. Consequently, the particles have greater freedom of movement, resulting in lower contact stresses with the tool surface. Thus sand particles tend to roll across the surface, and, if they are small enough, cause extrusion of the softer phase between the carbides. Eventually the carbides lose their support, and will either be plucked out or fracture.

Of the two tests conducted in sandy soils, field 1 had a larger fraction of fine particles, and the results show that microstructural properties do indeed become significant in controlling the wear rate. Under these conditions, a structure consisting of a very fine dispersion of small carbides in a strong matrix prevents the preferential removal of the latter, but at the same time the matrix resists crack initiation and propagation. Martensite, tempered at 320 °C shows the highest wear resistance. At higher tempering temperatures, the dispersed particles become increasingly coarse and

the strengthening effect continuously diminishes. Thus, even though toughness increases, hardness and strength decrease, and intrusion by the abrasive becomes easier, leading to higher wear rates.

Coarser sand particles, whilst not being able to intrude between the carbide particles, tend to fracture and generate cutting facets. Hence, as the abrasive particle size increases, matrix hardness will once again become the predominant factor controlling wear. This is borne out by the results of the test conducted in field 2, where the harder materials displayed the best performance. The overall lower wear resistance of materials in this field - as compared to field 1 - is due to the greater volume fraction of stones.

The effect of abrasive particles which fracture and embed themselves in the surface may be twofold. The relative wear resistance is likely to be increased in generally fine grained soils, as the embedded particle itself will act as a hard surface and prevent the attack of further particles. In the coarser soils, such embedded particles will cause fracture of further particles, and hence increase the rate of material removal.

Stoney soils. As the abrasive conditions become more severe, the improvements that can be provided by different types of heat treatment become less significant. The results of the tests conducted in stoney soils showed that the pearlitic structures performed as well or even better than martensitic and bainitic structures. It appears that toughness (to resist fracture on impact), and the work-hardening characteristics (to resist deformation), become more important. Even though the fields were situated next to one another and had the same composition, ranking orders changed in an apparently random fashion. The only structure giving consistently high performances was that of martensite tempered at 320 °C.

It is likely that the wear processes in such soils are a combination of impact, gouging, rubbing and rolling wear. The blue temper colour of the wear debris collected in the field suggests that heat generation during abrasion may play an important part and influence

the wear process. This observation is confirmed by the presence of white layers on the wear surface of specimens, microhardness traverses and X-ray diffraction analysis.

Overall, the tests have shown martensite tempered at a low temperature to give the best and most consistent performances. However, under extreme operating conditions, the only answer may well be to provide more steel to increase the wear life.

DATA TRANSFERABILITY BETWEEN FIELD AND LABORATORY TESTS

The high-stress 'fixed-abrasive' belt linisher test was found to give reproducible weight losses and to rank materials according to their hardness. The sigmoidal curve obtained when plotting RWR against hardness (Fig. 47a) is related to a transition from a ploughing mechanism (soft material) to a cutting mechanism (hard material), (Murray, Watson and Mutton, p. 9), as well as the ratio of material hardness to abrasive hardness (Richardson, Misra and Finnie, p. 13).

As expected, the ranking order correlates well with that found for abrasion in clayey soil; in both tests the principal wear mechanism is one of material removal through particle indentation.

The results of the dry sand/rubber wheel test (Fig. 47b) are not conclusive as only one test could be performed (weight losses of the second test, during which the rubber wheel deteriorated, were found to vary). Nevertheless, the results infer that both hardness and microstructural parameters are important. Stress levels are highest at the centre of the wear scar and particles will tend to penetrate into the surface. Material hardness is thus important in preventing large volume losses; the tempered martensites performed best in this region. At the points of abrasive particle entry and exit, the particles will roll rather than rub against the surface, and carbide morphology becomes the distinguishing parameter in resisting wear. Pearlitic structures were found to give good wear resistance at the lower hardness levels. The test thus simulates the wear processes

which occur in sandy soils, a conclusion also reached by Swanson (1984).

In summary, the two laboratory tests were found to correlate with the wear of materials in both clayey and sandy soils, but neither test could be related to the wear processes occurring in stoney soils.

WHITE LAYERS

The formation of non-etching layers on the wear specimens was thought to be a possible factor influencing the wear resistance of the different structures. Although these layers were also found in regions where no subsurface deformation was apparent, the largest proportion was observed on the bottom surface of specimens worn in stoney soil. White layers were not observed on the sides of specimens, i.e. where particles roll or slide rather than impact. Such an observation suggests that both heating effects (temper colour of wear debris) and high deformation rates (impact by stones) are important in their formation.

X-ray diffractometry revealed that austenite was present on the bottom surface, but not in either the bulk or at the sides of the specimens. This is strong evidence that heating effects during field testing are sufficient to cause austenitisation of the structure. Subsequent rapid cooling of these heated surface layers would promote the retention of some retained austenite in such high carbon steels.

Microhardness measurements taken in surface regions where no white layers could be distinguished (Fig. 71) also indicated that temperature effects are important. Because of extremely high heating rates, carbon is more likely to go into solution in structures containing a fine distribution of carbides, such as the tempered martensitic and bainitic structures (specimens 8, 2 and 3). Cooling rates are also likely to cause the transformation of this austenite to martensite. (Strain induced transformation of austenite to martensite is also a possibility.) Such steels are thus expected to show high surface hardness as a result of this thermo-mechanical treatment, and this is indeed seen to be the case. The decrease in hardness between the transformed layer and the bulk is probably due

to the attainment of subcritical temperatures in this region, having a tempering or annealing effect on the bulk structure.

It should be pointed out that the specimens used in this investigation were those sectioned after the second test in stoney soil, in which the normalized structure (1) performed best. The hardness of this specimen was found to increase consistently from the bulk to the surface layer. It would thus seem that the heating effects are not sufficiently prolonged to allow dissolution of the coarse cementite particles in these steels. Thus no martensite is formed and any increase in surface hardness layers would be due entirely to work-hardening effects. It may well be that the properties so obtained - a tough, strong structure with a surface hardness of 350 HV30, resulted in the increase in wear resistance. The presence of large carbide spheroids in the white layer of AISI O1 steel (Fig. 72) is contrary to previous observations, and it appears that a high carbon content of the matrix is an important prerequisite for their formation.

More advanced explanations than can be proffered from these limited results may be found in the literature survey, and will for that reason not be repeated here. The results indicate that the formation of white layers, especially on tough materials, may be advantageous to the wear resistance of steels. Further research is required to determine their structure - and hence formation mechanisms - in order to evaluate their influence on the abrasive wear in soils.

CHAPTER 6

CONCLUSIONS

The differences in the wear behaviour of the steel used in the present study can be correlated with microstructure and soil constitution.

1. For use in clayey soils, the hardness of the steel is an important parameter. Soil particles indent the tool surface and cause wear through a ploughing or cutting mechanism. The best performance was displayed by a lower bainitic structure with a hardness of 557 HV30, but a martensitic structure with a hardness of 463 HV30 is more likely to give good performance in practical applications.

2. For use in sandy soils, the presence of finely dispersed carbides bonded to a strong matrix results in an improvement in wear behaviour. Gradual attrition of the carbides controls the wear rates in fine soil aggregates. Large soil particles are more prone to fracture, causing preferential wear of the matrix.

3. For use in stoney soils, the toughness and strength of the material are important factors in resisting impact and improving wear resistance. Wear occurs by a combination of impact, gouging, ploughing and cutting processes, and is complicated by the influence of temperature on the structure. Steel with a pearlitic structure was found to perform well.

4. The best performance in all soils was displayed by a martensitic structure with a hardness of 463 HV30. This structure is the easiest to produce and requires the least complex equipment.

5. Further savings can be achieved by thickening the ripper points. This will a) reduce the amount of catastrophic failures

at high hardness levels and b) ensure lower replacement frequencies.

6. The belt linisher abrasion tester may be used to rank materials for use in clayey soils, but the hardness of the material itself gives an indication of the performance which can be expected.

7. Indications are that the dry sand/rubber wheel abrasion tester may be used to rank materials in sandy soils.

8. Extremely hard non-etching layers are formed on the tool surface under conditions of high deformation. These layers may prove to be beneficial in reducing the wear of steels in stoney soils.

CHAPTER 7

FURTHER WORK

Further work in this field should be concerned with the practical application of materials. Implements can be subjected to large scale tests by farmers in varying soil conditions, and the data thus acquired evaluated on a scientific basis. Stringent quality control of the material and its heat treatment (which seems to have been lacking in this respect, Quirke 1987) is essential in this regard.

From the results obtained it can then be established whether white layers are of any advantage in resisting wear. Should their presence be beneficial, formation mechanisms will have to be elucidated, and, once known, steels can be selected such that their formation is optimized.

Lower carbon boron steels appear to have the advantage that they can be used in the as quenched condition. Tests should be conducted in clayey and sandy soils to establish and evaluate the possibility of increases in wear resistance.

BIBLIOGRAPHY

- (1) ALLEN C., BALL A. and PROTHEROE B.E. (1981) *The abrasive-corrosive wear of stainless steels*. *Wear*, **74**, 287 - 305
- (2) ATKINS M. *Atlas of CCT diagrams for engineering steels*
- (3) AVERY H.S. (1981) *An analysis of the rubber wheel abrasion test*. Mahwah, New Jersey
- (4) BEDFORD A.J., WINGROVE A.L. and THOMPSON K.R.L. (1974) *The phenomenon of adiabatic shear formation*. *Jnl. of the Australian Institute of Metals*, **19**, (1)
- (5) BORIK F. (1970) *Rubber wheel abrasion test*. Climax Molybdenum Co. of Michigan publ.
- (6) CLAYTON P. (1980) *The relationship between wear behavior and basic material properties for pearlitic steels*. *Wear*, **60**, 75-93
- (7) COOPER J.K. (1981) *Wear of ground engaging parts - a report on pilot investigation for the division of agricultural engineering*. S.A. Dept. of Agriculture
- (8) COOPER J.K. (1986) *The effect of carbon content, heat treatment, shape and thickness on the linear wear of chisel plough points*. Report for S.A. Dept. of Agricultural Engineering and Water Supply
- (9) CSIR REPORT (1980) *Background document on wear in the agricultural sector*.
- (10) CZICHOS H. (1978) *Tribology, Series 1, 'A Systems Approach'*.
- (11) ELLEN H. (1984) *Tillage effects and specific energy requirements of rotary tillage*. *Soil and Tillage Research*, **4**, 471-484
- (12) ELLIOT P., FOWLER C.M., JOHNSON J.B., WOOD C.J. (1983) *Corrosion and materials degradation in the agricultural industry*. *The Agricultural Engineer*, 13-20
- (13) EYRE T.S. (1979) *Wear resistance of metals*. *Treatise on Materials Science and Technology*, **13**, 363-441
- (14) EYRE T.S. and MAYNARD D. (1971) *Surface aspects of unlubricated metal to metal wear*. *Wear*, **18**, 301-310
- (15) EYRE T.S. and BAXTER A. (1972) *The formation of white layers at rubbing surfaces*. *Tribology*, Dec. 1972, 256-261
- (16) FARMER H.N. (1974) *Factors affecting selection and performance of hard-facing alloys*. *Materials for the Mining Industry*, Preprint No.5

- (17) FARRELL R.M. and EYRE T.S. (1970) *The relationship between load and sliding distance in the initiation of mild wear in steels.* Wear, 15, 359-372
- (18) FELD H. and WALTER P. (1975) *Contribution to the understanding of mineral hard abrasive wear.* Powder Metallurgy International, 7, (4)
- (19) FOLEY A. (1984) *Abrasive wear of cultivation equipment by soil.* Soil and Water, 12, (12)
- (20) FOLEY A.G. , LAWTON P.J. , BARKER A.W. , MCLEES V.A. (1980) *The use of alumina ceramic to reduce wear of soil engaging components.* J. Agric. Engng. Res., 30, 37-46
- (21) FULCHER J.K. , KOSEL H. and FIORE N.F. (1981) *The effect of carbide volume fraction on the low stress abraion resistance of high Cr-Mo white cast irons.* Wear of Materials, 432-438
- (22) FULLER A.G. (1985) *Austempered ductile irons - present applications.* Materials and Design, 6, (3), 127-130
- (23) GARRISON W.M. and GARRIGA R.A. (1983) *Ductility and the abra-sive wear of an ultra high strength steel.* Wear, 85, 347-355
- (24) GLENN R.C. and LESLIE W.C. (1971) *The nature of "white streaks" in impacted steel armour plate.* Metallurgical Transactions, 2, 2945-2947
- (25) GRANGE R.A. , HRIBAL C.R. and PORTER L.F. (1977) *Hardness of tempered martensite in carbon and low-alloy steels.* Metallurgical Transactions, 8A, 1775-1785
- (26) GRAY G.T., THOMPSON A.W. and WILLIAMS J.C. (1985) *Influence of microstructure on fatigue crack initiation in fully pearlitic steels.* Metallurgical Transactions, 16A, 753-759
- (27) GRIFFITHS B.J. (1984) *White layer formations at machined sur-faces and their relationship to white layer formation at worn surfaces.* Paper submitted to the ASME/ASLE Lubrication Conference, San Diego, Oct 1984
- (28) GUNDLACH R.B. and PARKS J.L. (1978) *Influence of abrasive hardness on the wear resistance of high chromium irons.* Wear, 46, 97-108
- (29) HATA S. and MURO T. (1969) *Mechanisms of friction and wear of steel plate against solidified sandy soil.*
- (30) HAU-BRACAMONTE J.L. and WISE M.L.H. (1983) *Austenitization of steel during chip formation.* Metallurgical Transactions, 14A, 1743-1745

- (31) HUANG DER-HUNG and THOMAS G. (1977) *Metallography of bainitic transformation in silicon containing steels.* Metallurgical Transactions, 8A, 1661-1674
- (32) HUGHES I.C.H. (1985) *Austempered ductile irons - their properties and significance.* Materials and Design, 6, (3), 124-126
- (33) IVES L.K. (1983) *A method for preparing cross-sections of films on wear surfaces for TEM study.* Wear, 86, 151-156
- (34) KAR N.J. (1981) *Investigation of the role of microstructure on the two body abrasive wear of steels.* Wear of Materials, 1981, 415-425
- (35) KASHCHEEV V.N. (1983) *Some aspects of improving abrasion resistance.* Wear, 89, 265-272
- (36) KENNEDY F.E. (1984) *Thermal and thermomechanical effects in dry sliding.* Wear, 100, 453-476
- (37) KIDSON D. , COUPERTHWAITE R. and BAILEY M. (1984) *Wear of ground engaging farm implements.* Univ. Witwatersrand, Nov 1984
- (38) KISHEN KOUL M. and McVICKER C.L. (1976) *A new look at boron steels.* Metal Progress, Nov. 1976, 40-44
- (39) KOMAROV V.A. and MEDVEDEV M.A. (1982) *White zone formation in scuffing of multialloy gray cast irons.* Trenie i Iznos, 3, (6), 1079-1085
- (40) KRAGHEL'SKII I.V. and LOGINOV A.R. (1983) *Prediction of wear rate by theoretical experimental method.* Wear of Materials, 1983, 394-401
- (41) KRAUSE H. and SENUMA T. (1982) *A contribution towards improving the applicability of laboratory wear tests to practice.* Wear, 74, 67-83
- (42) KRUSHOV M.M. and BABICHEV M.A. (1958) *Resistance to abrasive wear of structurally heterogenous materials.* Friction and Wear in Machinery, 12, 12-26
- (43) KWOK C.K. and THOMAS G. (1983) *Microstructural influence on abrasive wear resistance of high strength/high toughness medium carbon steels.* Wear of Materials, 1983, 140-147
- (44) LARSEN-BADSE J. (1972) *Some effects of specimen size on abrasive wear.* Wear, 19, 27-35
- (45) LARSEN-BADSE J. and Premaratne B. (1983) *Effect of relative hardness on transitions in abrasive wear mechanisms.* Wear of Materials, 1983, 161-166
- (46) LIU Y.J., YAND R.L., CHENG K.Q. and DENG H.J. (1981) *Wear of materials under dynamic loading.* Wear of Materials, 1981, 390-395

- (47) LUDEMA K.C. *Selecting material for wear resistance.*
- (48) MARDER A.R., PERPETUA S.M., KOWALIK J.A. and STEPHENSON E.T. (1985) *The effect of carbon content on the kinetics of decarburization in Fe-C alloys.* Metallurgical Transactions, 16a, 1160-1163
- (49) MASHLOOSH K.M. and EYRE T.S. (1985) *Abrasive wear and its application to digger teeth.* Tribology International, 18, (5)
- (50) McLEES V.A. and MOORE M.A. (1976) *A preliminary investigation into the effect of surface treatments in reducing metal-soil-metal abrasive wear of elevator links.* NIAE report
- (51) McQUEER J.I. (1985) *Abrasion resistance of a series of vanadium white cast irons.* MSc Thesis, Univ. Cape Town, Dept. Materials Engineering
- (52) ME-BAR Y. and SCHECHTMAN D. (1983) *On the adiabatic shear of Ti-6Al-4V ballistic targets.* Materials Science and Engineering, 58, 181-188
- (53) MILLER A.E. (1980) *Wear in tillage tools.* Wear Control Handbook, 987-996
- (54) MISRA A. and FINNIE I. (1980) *A classification of three body abrasive wear and the design of a new tester.* Wear, 60, 111-121
- (55) MISRA A. and FINNIE I. (1981a) *An experimental study of three body abrasive wear.* Wear of Materials, 1981, 426-431
- (56) MISRA A. and FINNIE I. (1981b) *Some observations of two body abrasive wear.* Wear, 68, 41-46
- (57) MISRA A. and FINNIE I. (1981c) *Correlations between two-body and three-body abrasion and erosion of metals.* Wear, 68, 33-39
- (58) MOORE M.A. (1971) *A preliminary investigation of frictional heating during abrasive wear.* Wear, 17, 51-58
- (59) MOORE M.A. (1974) *A review of two-body abrasive wear.* Wear, 27, 1-17
- (60) MOORE M.A. (1979) *Abrasive wear.* Treatise on Materials Science and Technology, 13
- (61) MOORE M.A. (1980) *The influence of material properties on abrasive particle contact and volume wear.* Metaux, (653)
- (62) MOORE M.A. (1986) *Laboratory simulation testing for service abrasive wear emulations.* Fulmer Research Institute publ.

- (63) MOORE M.A. and DOUTHWAITE R.M. (1976) *Plastic deformation below worn surfaces*. Metallurgical Transactions, 7a
- (64) MOORE M.A. and KING F.S. (1980) *Abrasive wear of brittle solids*. Wear, 60, 123-140
- (65) MOORE M.A. and McLEES V.A. (1980) *Effect of speed on wear of steels and copper by bonded abrasives and solids*. J. Engng. Res, 25, 37-45
- (66) MOORE M.A., RICHARDSON R.C.D. and ATTWOOD D.G. (1972) *The limiting strength of worn metal surfaces*. Metallurgical Transactions, 3, 2485-2491
- (67) MOORE M.A. and SWANSON P.A. (1985) *The effect of particle shape on abrasive wear: A comparison of theory and experiment*. Publ. Deere & Company, Technical Centre
- (68) MURRAY M.J., WATSON J.D. and MUTTON P.J. (1971) *Abrasive wear mechanisms in steels*. Paper presented at the C.S.I.R.O. Division of Materials Science, Parkville, Victoria, Australia
- (69) MUTTON P.J. and WATSON J.D. (1978) *Some effects of microstructure on the abrasion resistance of metals*. Wear, 48, 385-398
- (70) NEWCOMB S.B. and STOBBS W.M. (1984) *A transmission electron microscope study of the white etching layer on a rail head*. Materials Science and Engineering, 66, 195-204
- (71) NTIS REPORT (1984) *Wear of agricultural machine parts*. U.S. Dept. of Agriculture - National Technical Information Service, Publ. #PD 84-230085 (Translation from the Russian).
- (72) PEARCE J.T.H. (1983) *The use of TEM to study the effects of abrasive wear on the matrix structure of a high chromium cast iron*. Wear, 89, 333-344
- (73) PRASAD N. and KULKARNI S.D. (1980) *Relation between microstructure and abrasive wear of plain carbon steels*. Wear, 63, 329-338
- (74) PRICE L.H. (1983) *Fighting wear in agricultural and off-road equipment*. Metal Progress, Aug 1983, 21-27
- (75) QIONGLI W., PEIEN X., SHIUMEI S. and CUIZHEN X. (1983) *On the mechanism of wet abrasive erosion*. Tribology International, 18, (2)
- (76) QUICK G.R., WOODS C.R. and BARTLETT N.R. (1973) *Effects of speed and other parameters on lineal share wear*. Paper presented at AESA Tillage Conference, Aug. 1973
- (77) QUINN T.F.J. (1984) *The role of wear in the failure of common tribo systems*. Wear, 100, 399-436

- (78) QUIRKE S. (1983) *Wear behavior of agricultural implements / Reports on three plough shares / Report on agricultural materials.* Reports - Univ. Cape Town, Dept. Materials Engineering
- (79) QUIRKE S., SCHEFFLER O. and ALLEN C. (1986) *The development of a field test for the evaluation of materials for use in tillage tools.* Presented at SAIT conference on "Wear in Agriculture", Johannesburg, S.A.
- (80) RABINOWICZ E. (1984) *The least wear.* Wear, 100, 533-531
- (81) RICE S.L., NOWOTNY H. and WAYNE S.F. (1981) *Characteristics of metallic subsurface zones in sliding and impact wear.* Wear of Materials, 1981, 47-52
- (82) RICHARDSON R.C.D. (1967a) *The wear of metals by hard abrasives.* Wear, 10, 291-309
- (83) RICHARDSON R.C.D. (1967b) *The maximum hardness of strained surfaces and the abrasive wear of metals and alloys.* Wear, 10, 353 - 382
- (84) RICHARDSON R.C.D. (1967c) *The wear of metallic materials by soil - particle phenomena.* J. Agric. Engng. Res., 12, (1), 22-39
- (85) RICHARDSON R.C.D. (1968) *The wear of metals by relatively soft abrasives.* Wear, 11, 245-275
- (86) RIGNEY D.A., CHEN L.H., NAYLOR M.G.S. and ROSENFELD A.R. (1984) *Wear processes in sliding systems.* Wear, 100, 195-219
- (87) RIGNEY D.A. and GLAESER W.A. (1978) *Wear Resistance.* ASM Metals Handbook, 9th Edition, 1, 597-638
- (88) RINEBOLT J.A. (1969) *A new group of boron treated steels.* Metal Progress, Sep. 1969, 117-122
- (89) ROGERS H.C. (1979) *Adiabatic plastic deformation.* Ann. Rev. Materials Science, 9, 283-311
- (90) SALESKY W.J. and THOMAS G. (1981) *Design of medium carbon steels for wear applications.* Wear of Materials, 1981, 298-305
- (91) SALESKY W.J., FISHER R.M., RITCHIE R.O. and THOMAS G. (1983) *The nature and origin of sliding wear debris.* Wear of Materials, 1983, 434-445
- (92) SCOTT D. (1979) *Wear. Treatise on materials science and technology,* 13
- (93) SCOTT D., SMITH A.I., TAIT J. and TREMAIN G.R. (1975) *Materials and metallurgical aspects of piston ring scuffing - a literature review.* Wear, 33, 293-315

- (94) SMART R.F. and MOORE J.C. (1979) *Materials selection for wear resistance*. *Wear*, 56, 55-67
- (95) SMITHELLS C.J. (1976) *Electron metallography*. Metals Reference Book, 5th Edition, 1976
- (96) SPURR R.T. (1981) *The abrasive wear of metals*. *Wear*, 68, 272 - 282
- (97) STAKER M.A. (1980) *The relation between adiabatic shear band determination by surface observations*. *Scripta Metallurgica*, 14, 677-680
- (98) SUH N.P. (1980) *New theories on wear and their implications for tool materials*. *Wear*, 62, 1-20
- (99) SWANSON P.A. *Comparison of laboratory and field abrasion tests*. Report - Deere & Co. Technical Centre, Moline, Illinois, USA
- (100) SWANSON P.A. and KLANN R.W. (1981) *Abrasive wear studies using the wet sand and dry sand rubber wheel tests*. *Wear of Materials*, 1981, 379-389
- (101) SWANSON P.A. and VETTER A.F. (1984) *The measurement of abrasive particle shape and its effect on wear*. *ASLE Transactions*, 28, (2), 225-230
- (102) TORRANCE A.A. (1980) *The correlation of abrasive wear tests*. *Wear*, 63, 359-370
- (103) TORRANCE A.A. (1981) *An explanation for the hardness differential needed for abrasion*. *Wear*, 68, 263-266
- (104) WAYNE S.F., RICE S.L., MINAKAWA K. and NOWOTNY H. (1983) *The role of microstructure in the wear of selected steels*. *Wear*, 85, 93-106
- (105) WELLS M.G.H. (1964) *An electron transmission study of the tempering of martensite in an FE-Ni-C alloy*. *Acta Metallurgica*, 12
- (106) WINGROVE A.L. (1971) *A note on the structure of adiabatic shear bands in steel*. *J. Australian Institute of Metals*, 16, (1), 67-70
- (107) WINGROVE A.L. and WULFF G.L. (1973) *Some aspects of target and projectile properties on penetration behavior*. *J. Australian Institute of Metals*, 18, (4)
- (108) WOODWARD R.L. (1979) *Metallographic features associated with the penetration of titanium alloy targets*. *Metallurgical Transactions*, 10a, 569-573
- (109) VIJH A.K. (1975) *The influence of solid state cohesion of metals and non-metals on the magnitude of their abrasive wear resistance*. *Wear*, 35, 205-209

- (110) VINGSBO O. (1979) *Wear and wear mechanisms*. *Wear of Materials*, 620-635 (ASME publ.)
- (111) ZUM GAHR K.H. (1981) *Formation of wear debris due to abrasion*. *Wear of Materials*, 1981, 396-405
- (112) ZUM GAHR K.H. and ELDIS G.T. (1980) *Abrasive wear of white cast irons*. *Wear*, 64, 175-195
- (113) ZUM GAHR K.H. and MEWES D. (1983) *Severity of material removal in abrasive wear of ductile metals*. *Wear of Materials*, 1983, 103-139

APPENDIX 1

FIELD TEST RESULTS: CALCULATIONS

The rapid calculation and manipulation of results was facilitated by specially written computer programs. Weight losses obtained in the field were converted to volume losses by taking into account the respective densities of the steels as determined in the laboratory (SS10/83: 7.812, SS10/200: 7.803).

In order to correct the wear test results for the pivoting motions and any possible misalignment of the test rig, the 'RWR (correction factor)' was calculated from the set consisting of reference material only (S1) for every field test series by

$$\text{RWR (corr. factor)} = \frac{\text{wear rate of centre two positions}}{\text{wear rate of outer four positions}} :$$

FIELD	RWR (CF)	OUTER 4	CORR.	CENTER 2	CORR.	%VAR
Stone 1	.98	2.72	.9993	2.66	.9886	2.91
Stone 2	.98	2.71	.9988	2.66	.9995	3.03
Sand 1	.85	.35	.9999	.30	.9988	1.78
Sand 2	1.24	.13	.9179	.16	.9231	3.22
Clay	.80	.36	.9808	.29	.9852	1.68

Table A1: RWR correction factors (RWR CF) determined from set S1.

where 'OUTER 4' and 'CENTER 2' are the wear rates (in cm³/km) of the outer four and center two positions respectively; 'CORR.' is the correlation coefficient as determined by linear regression and %VAR depicts the ratio of standard deviation to sample mean.

The relative wear resistance of the 'test' material (housed in the center two positions on the test rig) was then calculated by

$$\text{RWR} = \frac{\frac{\text{wear rate of reference steel}}{\text{wear rate of 'test' steel}}}{\text{RWR (correction factor)}} ,$$

the results of which are given on the next page.

Table A2: Field test results - numerical data

SET	RWR	TEST	CORR.	REF.	CORR.	%VAR	
5	1.47	2.48	.9997	3.57	.9927	9.78	STONE 1
2	1.34	2.48	.9994	3.25	.9938	11.68	
6	1.27	2.74	.9976	3.41	.9936	7.05	
8	1.21	2.47	.9979	2.93	.9916	11.38	
7	1.20	2.56	.9975	3.02	.9963	8.79	
3	1.20	2.63	.9994	3.09	.9993	5.36	
4	1.19	2.53	.9987	2.95	.9982	8.30	
1	1.17	2.58	.9990	2.96	.9990	6.45	
1	1.28	2.03	.9992	2.55	.9930	7.68	STONE 2
2	1.19	2.20	.9973	2.56	.9881	20.89	
5	1.10	1.94	.9991	2.09	.9962	5.77	
4	1.04	2.12	.9998	2.18	.9953	10.60	
3	1.03	2.13	.9999	2.16	.9980	5.42	
6	1.00	2.10	.9989	2.05	.9866	17.71	
8	.92	2.28	.9982	2.06	.9982	6.29	
7	.90	2.36	.9951	2.08	.9989	6.74	
2	2.17	.19	.8040	.35	.8137	6.68	SAND 1
3	2.04	.10	.9763	.17	.9838	10.66	
6	2.01	.08	.9965	.14	.9982	4.00	
8	1.92	.15	.8867	.25	.9216	22.40	
7	1.85	.07	.9697	.11	.9748	5.32	
5	1.77	.10	.9979	.16	.9958	2.70	
1	1.76	.18	.8390	.27	.7762	12.02	
4	1.67	.13	.9897	.19	.9923	6.58	
8	1.81	.13	.9755	.29	.9695	7.05	SAND 2
2	1.78	.14	.9698	.31	.9707	2.64	
6	1.66	.12	.9834	.25	.9790	7.47	
7	1.66	.15	.9662	.30	.9670	4.12	
5	1.65	.14	.9634	.29	.9792	14.72	
3	1.64	.15	.9638	.31	.9703	6.03	
1	1.62	.14	.9584	.27	.9648	6.41	
4	1.53	.16	.9689	.30	.9702	6.53	
8	2.35	.34	.9982	.64	.9993	4.76	CLAY
2	2.28	.37	.9995	.67	.9996	3.69	
3	2.05	.36	.9991	.59	.9996	2.91	
6	2.00	.36	.9989	.57	.9997	2.35	
4	2.00	.36	.9971	.57	.9983	2.63	
7	1.93	.27	.9894	.42	.9927	4.90	
1	1.86	.46	.9962	.68	.9977	1.66	
5	1.81	.41	.9996	.59	.9976	4.27	

SET = Test Set RWR = Relative Wear Resistance CORR = Correlation Coefficient
 TEST = Wear rate (cm³/km) of Test Material, SS10/83
 REF = Wear rate (cm³/km) of Reference Material, SS10/200
 %VAR = Ratio of std. deviation to sample mean