

PATH PLACE PAUSE: *Re-Establishing Vibrancy and Cultural Identity in Pniël by redefining the Square*

Hayley Mouton

Design Research Project APG 5079W

October 2015

Supervisors: Kevin Fellingham

This dissertation is presented as part fulfillment of the degree of Master of Architecture (Professional) in the School of Architecture, Planning and Geomatics, University of Cape Town

The copyright of this thesis vests in the author. No quotation from it or information derived from it is to be published without full acknowledgement of the source. The thesis is to be used for private study or non-commercial research purposes only.

Published by the University of Cape Town (UCT) in terms of the non-exclusive license granted to UCT by the author.

"I hereby:

a. Grant the University free license to reproduce the above dissertation in whole or in part, for the purpose of research.

b. Declare that:

(i) The above dissertation is my own unaided work, both in conception and execution, and that apart from the normal guidance of my supervisors, I have received no assistance apart from that stated below

(ii) Except as stated below, neither the substance or any part of the dissertation has been submitted for a degree in the University or any other university.

(iii) I am now presenting the dissertation for examination for the degree of Master of Architecture (Professional)"

Plagiarism Declaration:

1. I know that plagiarism is wrong. Plagiarism is to use another's work and pretend that it is one's own.

2. I have used the Harvard convention for citation and referencing. Each contribution to, and quotation in, this report from the work(s) of other people has been attributed, and has been cited and referenced.

3. This report is my own work.

4. I have not allowed, and will not allow, anyone to copy my work with the intention of passing it off as his or her own work.

Signature _____

Acknowledgements

I would like to thank my family and friends for their encouragement and support throughout my studies. Too my wonderful parents, thanks you for encouraging me along on this journey. I would like to express my appreciation to Kevin Fellingham for his invaluable assistance throughout this year.

Personal Reflection

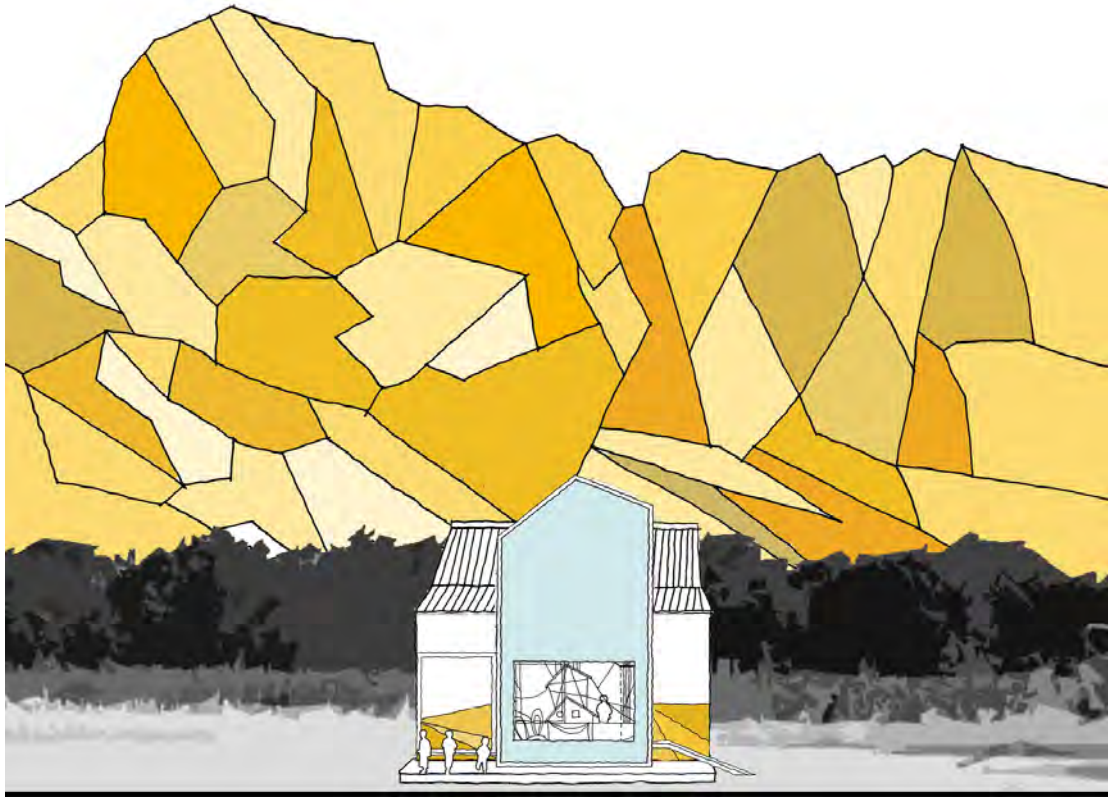

Figure 1: Re-Imagining the enchanting world within the built environment and its relation to its context.

As a child travelling to Pniël, the beauty of the landscape and the buildings located within it captivated me. When travelling along the path I imagined an enchanting world that existed within the built fabric and how the landscape and the built fabric could collide. The area has a spirit that can only be felt when one is within it and it is this spirit along with delightful childhood memories that provided the departure point for this dissertation.

Thesis Abstract

Buildings provide a source of culture and cultural identity, forming part of the cultural fabric of an area with traces of the past assisting in the development of a place (Fransen, 2006). Cultural identity appears to be threatened in many mission towns in South Africa as issues of gentrification, urbanization and a loss of cultural values become apparent. As such, an architectural intervention is needed to provide a connection between people and place, in order to retain the cultural identity of a place.

This dissertation explores how a spatial framework can re-establish lost space, specifically around the connection between path and place within a specific environment, namely Pniël. The investigation stems from the disconnection between people passing through Pniël and their interaction with the space. People travelling through this space never truly experience the spirit of the place while the path obstructs the people living within the place.

Furthermore, the investigation aims to celebrate tradition, heritage and cultural richness within this area while understanding what is involved in generating a sustainable social and economic environment. Creating a cultural landscape supports the making of a vibrant space; where the landscape speaks of the areas topography and the people within the landscape create the social vibrancy that defines the cultural landscape (Vosloo, 2010: 41).

Specific materials can be used to make people re-engage with the space. Architecture can reconcile the landscape and the place through the use of natural materials. Using clay provides a dialogue between the past and the present and can be used as a means to re-imagine space, assisting in the re-establishment of cultural vibrancy and economic development.

Table of Contents

Acknowledgements	3
Personal Reflection	4
Thesis Abstract	5
Introduction	9
001 The Environment	13
The Path and the People	13
The Square.....	18
002 The Typology of the Place	20
Cape Dutch Architecture in Pniël.....	20
003 The Development of the Cape Dutch House	24
004 The Mission Village and Homesteads in the Dwars River Valley	26
005 Theoretical Approach	29
5.1 Roger Trancik.....	29
5.2 Kevin Lynch	31
5.3 Gordon Cullen.....	32
5.4 Norberg-Schulz.....	33
006 Urban Strategy	35
6.1 Spatial Arrangement.....	40
6.2 Design Development	43
007 Using Elements of Cape Dutch Architecture to contain the Square	45
7.1 Elements of Cape Dutch Architecture.....	46
008 Technology	48
8. 1 Mud (Adobe) Bricks.....	48
8. 2 Rammed Earth.....	49
8.3 Clay	50
8. 4 Foundations	51
009 The making of Ceramic Components	52
Precedent Study.....	52
010 Final Thoughts	61
011 Bibliography	62

Table of Figures

Note: All images are produced by Author unless otherwise stated

Figure 2: Redrawn by Author. Sourced from: Fransen, H& Cook, MA. 1965. The old houses of the Cape Dutch. Cape Town and Amsterdam: Balkema

Figure 3: Redrawn by Author. Paul Andrews. 2005. Character Zones in the Boschendal Valley. Denis Moss Planners and Architects. Baumann and Winter Heritage Consultants: Boschendal Heritage Assessment: Founders Estates Application: Draft Report 2006.

Figure 6: National Geo- Spatial Information. 1936. Aerial Image of the Dwars River Valley, NTS. Denis Moss Planners and Architects

Figure 7: National Geo- Spatial Information. 1950. Aerial Image of the Dwars River Valley, NTS. Denis Moss Planners and Architects

Figure 8: National Geo- Spatial Information. 1998. Aerial Image of the Dwars River Valley, NTS. Denis Moss Planners and Architects

Figure 12: Redrawn by Author. Paul Andrews. 2005. Axes. Denis Moss Planners and Architects. Baumann and Winter Heritage Consultants: Boschendal Heritage Assessment: Founders Estates Application: Draft Report 2006.

Figure 14: Boschendal Wine Estate Redrawn by Author. Sourced from: Fagan G. 2006. An introduction to the man-made landscape at the Cape from the 17th to the 19th centuries (Volume 1). Cape Town: UCT

Figure 15: Redrawn by Author. Sourced from: De Bosdari. 1953. *Cape Dutch Houses and Farms*. Cape Town: A. A Balkema

Figure 16: Redrawn by Author. Paul Andrews. 2005. Werf patterns to fit into landscape grid pattern. Denis Moss Planners and Architects. Baumann and Winter Heritage Consultants: Boschendal Heritage Assessment: Founders Estates Application: Draft Report 2006.

Figure 17: Redrawn by Author. Sourced from: De Bosdari. 1953. *Cape Dutch Houses and Farms*. Cape Town: A. A Balkema

Figure 19: Sourced from: Trancik, R. 1986. *Finding Last Space: Theories of Urban Design*. New York: Van Nostrand Reinhold

Figure 20: Sourced from: Lynck, K. 1960. *The Image of the City*. Massachusetts: MIT Press.

Figure 21: Sourced from: Trancik, R. 1986. *Finding Last Space: Theories of Urban Design*. New York: Van Nostrand Reinhold

Figure 29: Minke, G. 2006. *Building with Earth: Design and Technology of a Sustainable Architecture*. Switzerland: Birkhauser

Figure 30: Minke, G. 2006. *Building with Earth: Design and Technology of a Sustainable Architecture*. Switzerland: Birkhauser

Figure 31: Ceramic tiles dipped in a glaze & ready to be fired. 2011.
<http://www.spierarchitecturalarts.co.za>

Figure 31: Spier Architectural Arts Programme. 2011.
<http://www.spierarchitecturalarts.co.za>

Introduction

The Dwars River Valley is made up of Pniël, Johannesdal, Kylemore and Lanquedoc, and forms part of the Cape Winelands with the surrounding mountains forming part of the Floral Kingdom World Heritage Site (DMP, 2011: 3). Pniël is located along the path between Stellenbosch and Franschhoek and is the oldest community in the valley (van der Waal, 2014: 9). The area has a distinctive character of Cape Dutch vernacular architecture with eminent homesteads (DMP, 2011: 3). Additionally, it has a legacy of slavery and agriculture and was established in the 1840's as a mission station (van der Waal, 2014: 9).

Pniël's landscape is made up of a path that extends into a place. However there appears to be a disconnection between path and place within this specific spatial environment. The path obstructs people living in the space while the people traveling through the space never truly engage with the space. I am interested in understanding how an environment works as a system of paths and places, and how these paths interact with a place.

An awareness of the locality and beauty of Pniël has made the value of this area apparent to investors, leaving community members to question their values and traditions in the face of urbanization (Kotze, 2013: 126). In addition, gentrification has had an effect on the area and threatens the cultural heritage of this area. Therefore, many mission villages are faced with potential social and economic challenges in its present reality.

Kees van der Waal (2014:16) identifies that the process of gentrification may lead to resentment from those who treasure the heritage and locality of their environment. Therefore, the progression of an area in a manner that promotes social vibrancy and encourages economic development while safeguarding heritage and traditions is encouraged.

Cultural heritage in Pniël and similar mission towns should be preserved as a loss of cultural heritage can be seen as a loss of identity. Without remembering our past, society cannot advance as our present and future conditions are influenced by the past (Treib, 2009:18). So, the inherent materials and the socio-economic conditions need to be considered when designing within the context as it impacts the cultural landscape of an area.

A cultural landscape rich in heritage and tradition can provide people with a sense of place and belonging (DMP, 2010: 32). Consequently, the interaction between the natural landscape and its people can provide a rich cultural environment (Fransen, 2006: 1). Building typologies provide communities with a connection to their buildings and provide areas with a sense of space (DMP, 2010: 34). The historical tradition of the people as well as the materiality of the built environment is a visual reminder of identity.

This dissertation seeks to redefine the town square in Pniël. Changes to the path create a spatial environment that encourages people to pause along the path. Principles of Cape Dutch Architecture are reinterpreted and ideas of placemaking are used in the making of the building and its spatial environment.

Tradition, heritage and cultural richness are celebrated through the built fabric. As such, a strategy is adopted that places services within the thick exterior earth walls of the building. Sacred spaces are found within the interior of this building. Contemporary ceramic components are strategically placed within these sacred spaces. Community members are educated in the art of ceramics and assist in creating a vibrant cultural space within the community.



Figure 2: Pniël in the context of the Dwars River Valley and the broader region

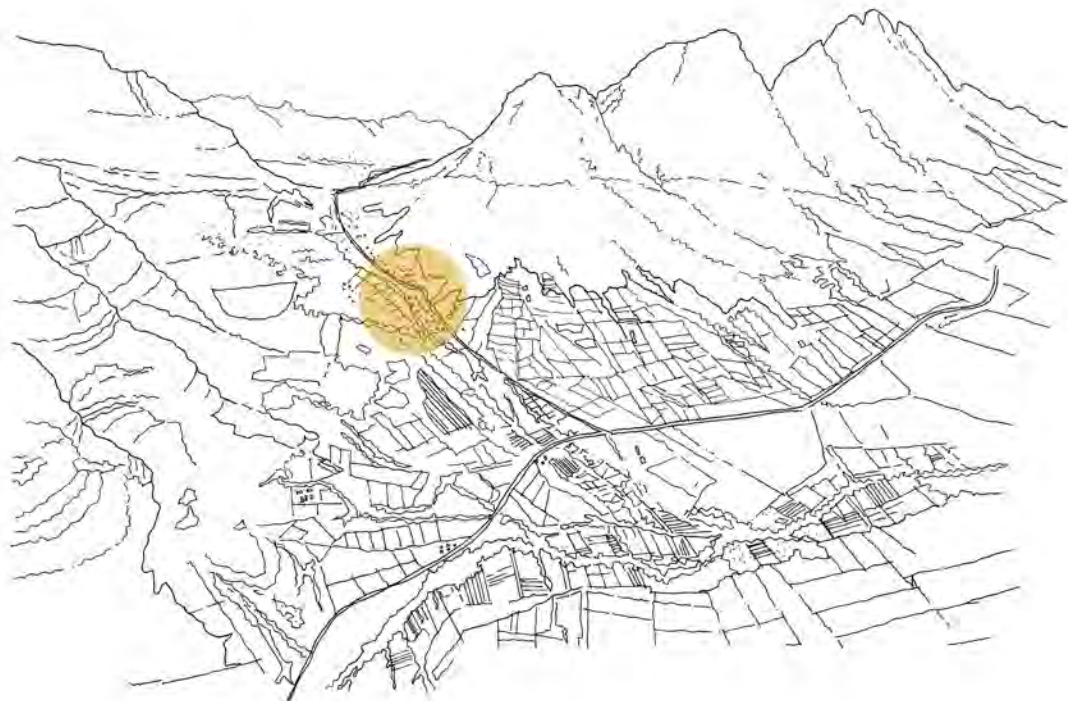

Figure 3: Locating Pniël in the Dwars River Valley



Figure 4: The path (Helshoogte Road) that extends into the place



Figure 5: Pniël's Main Road

001 The Environment

The Path and the People

The people within this spatial environment make up the cultural fabric of the place. So to experience the cultural fabric of the place one needs to engage with Pniël and its people. Changes in the path that supports this engagement should therefore be encouraged. Historical maps provide lessons about the area and demonstrate how the built fabric has developed.

Aerial maps of this area depict a significant change in the path between 1936 and 1950. The path straightens considerably during this period and changes are most evident along the center of the path. Residential dwellings once seen on the left are now visible on the right of the path.

Between 1950 and 1998 the row houses located towards the right of the square are moved further away from the path. This alters the edge condition between the path and the built fabric.

Traffic passes with much ease through the area and people travelling along the path are not encouraged to engage with the space. Pausing along a significant space can create an opportunity for social engagement; however, buildings and the spaces alongside it should support these activities.



Figure 6: Aerial Map 1936, depicts a winding road

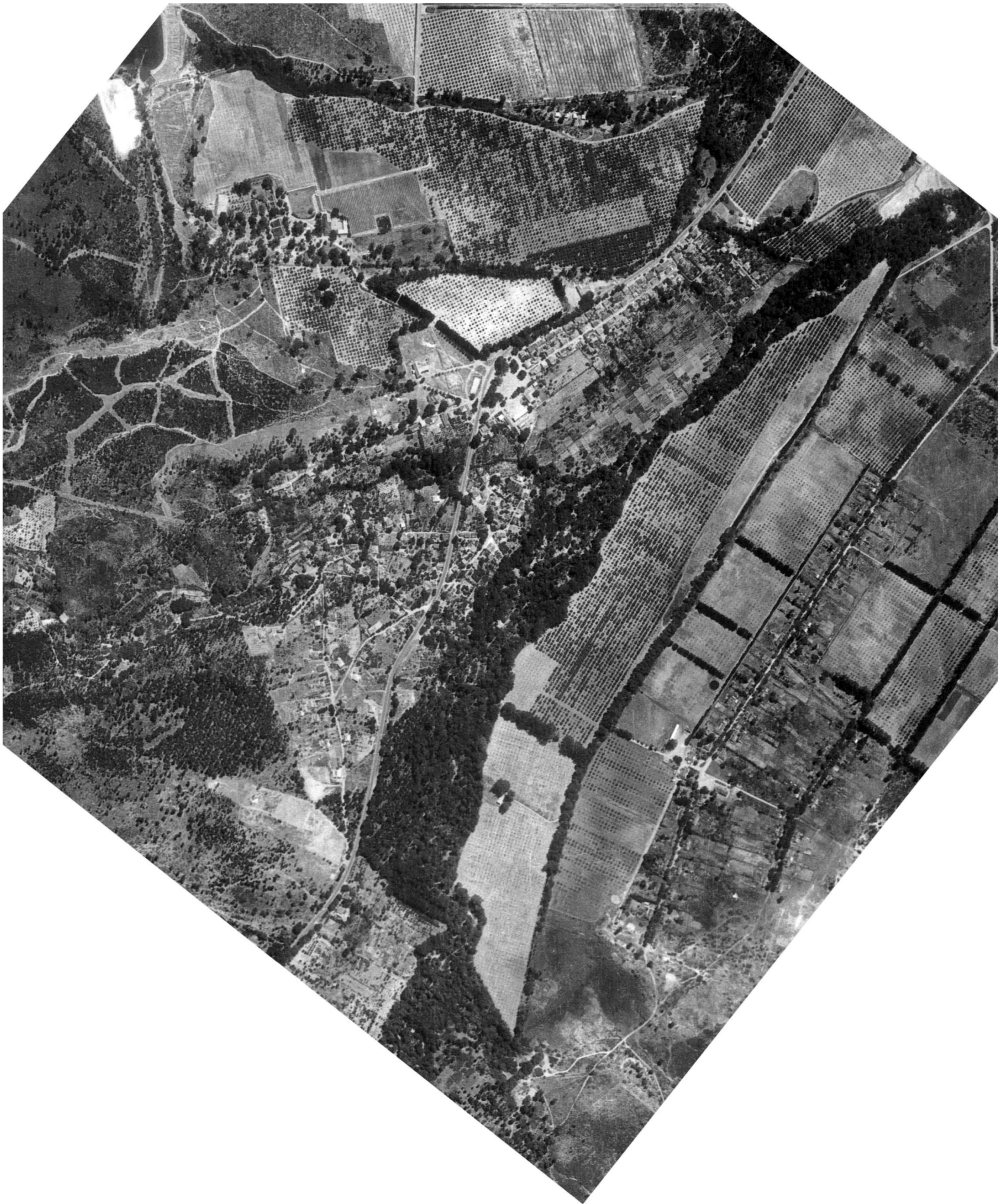

Figure 7: Aerial Map 1950, a significantly straighter road



Figure 8: Arial Map 1998, the row houses located towards the right of the square has been pushed back and the path is altered once again.

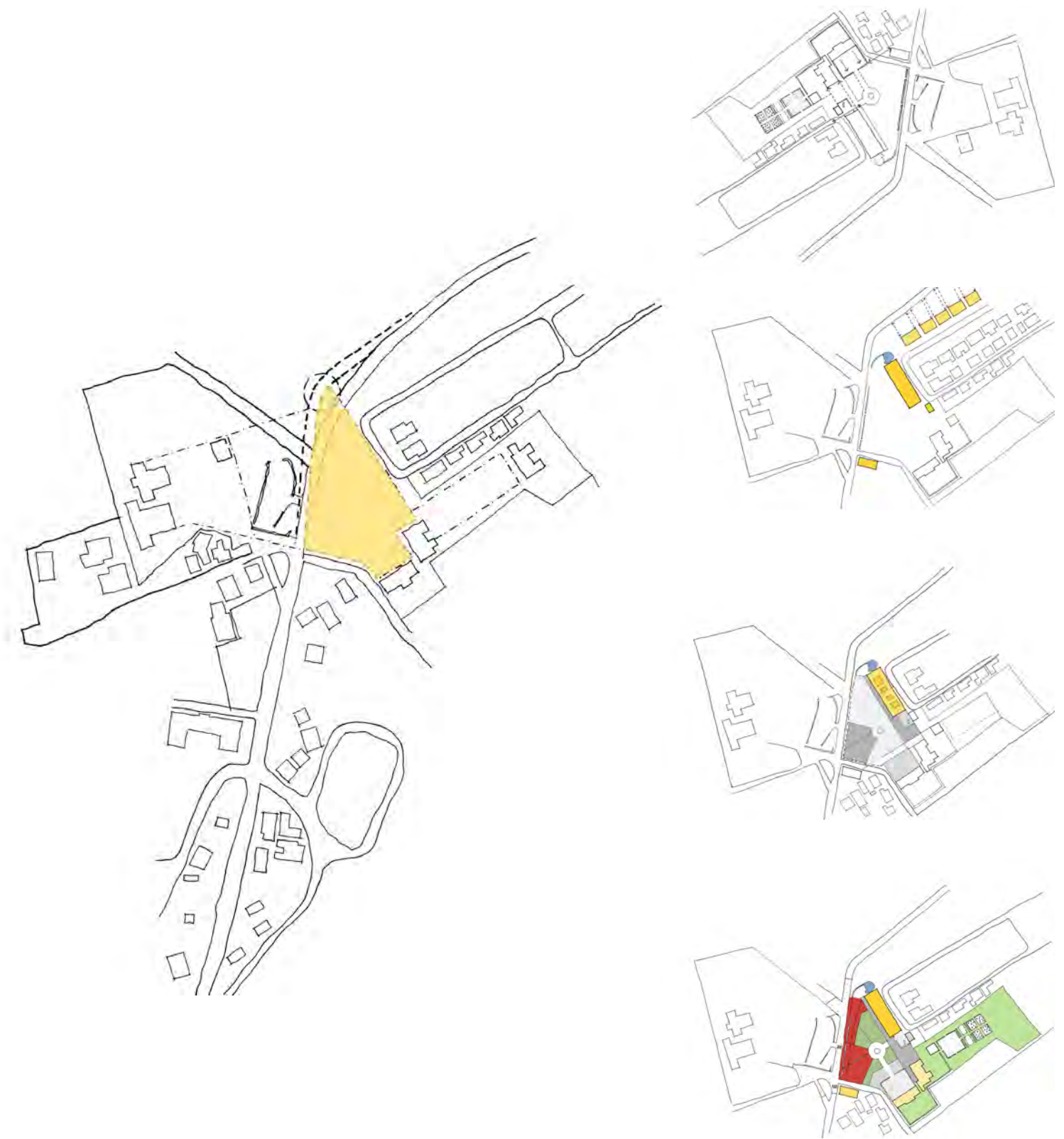

Figure 9: Creating an environment that encourages people to stop along the path.

The Square

Pniël maintains a strong sense of community and Christian values. This is evident in the congregation's commitment to the Church (van der Waal, 2014:19). Religion and social activity serves as a powerful means to influence the environmental conditions of a mission village. Importance is attached to various aspect of life through its built fabric, which can be seen as an expression of the ideals of a community through the making of tangible things (Rapoport, 1969: 47).

The Church, museum, crèche and historical monuments are located within the town square. Buildings within the square appear to stand far apart and there are no strict building lines (Fransen, 2006: 2). The scale of the Church and its location provides this building with a sense of importance in the landscape. The community has a culture of gathering and social interaction. Large amounts of open space within the town square provide a space for cultural activity.



Figure 10: The Congregational church in Pniël is located with a sense of importance in the landscape



Figure 11: Locating Buildings in the Square

Images

1. Church
2. Church Hall
3. Spaza Shop
4. Museum
5. Crèche
6. Popup Shop
7. Garden
8. Municipal

002 The Typology of the Place

Cape Dutch Architecture in Pniël

The building typology of a place is rooted in its cultural history and its climatic conditions (Vosloo, 2010: 42). The town, the community and its traditions set out the area's architectural form and support the establishment of a place. It appears that a willful relationship between the organic and the inorganic coexists (Fransen, 2006: 1). The buildings in Pniël are located with great sensitivity in the landscape, and there is a clear concern with its connection to opposing natural elements that provide a rich setting for the placement of built fabric (Fagan, 2005: 1). The appreciation of the landscape and the placement of the buildings within the landscape offer buildings a sense of importance in the landscape (Fagan, 2005: 1). Vernacular architecture expresses the society in which it is found (Rapoort, 1969: 3). Social conditions and environmentally appropriate materials should form the basis from which identity and architectural development exists (Vosloo, 2010: 41). Vernacular architecture provides an area with a built fabric that is socially and environmentally appropriate for its local context (Heath, 2009: 77).

The Dutch East India Company established a trading station at the Cape of Good Hope and constructed architecture that resembled what was found within the local Dutch context (Vosloo, 2010: 42). The Cape Dutch architectural style was influenced by Dutch architecture and was adapted to suit building in the climatic conditions in the Cape (Vosloo, 2010: 42). Along with the varied climatic conditions came material limitations and adequate labour. This resulted in the emergence of Cape Vernacular (Floyd, 1983: 28). The Cape Dutch architectural style can therefore be seen as an expression of local identity within a global economic system (Vosloo, 2010:42).

Buildings located in Pniël are characterized by this architectural style. The Cape Dutch homesteads in the Dwars River Valley date back to the early nineteenth

century (van der Waal, 2014: 3). Its architecture provides this place with a strong connection to its past.

The spatial layout of the Cape Dutch homestead is characterized by parts that make a whole. Ideas of creating rooms within rooms are apparent on both an urban, precinct and building scale. Boschendal is located within the Dwars River Valley. This homestead is made up of various buildings contained within the werf. The manor house is placed along the center on the avenue with additional buildings positioned along this avenue. These buildings support the activities of the manor house while the placement of these buildings within the werf contributed to the homesteads character.

Homesteads are largely located in the middle of the property reflecting romantic ideals of the building and its relationship to the landscape (Fransen, 2006: 30). The spatial structure of the farm reflects similarities to that of a mission village. Pniël is designed along the same principles as the homestead. The Church is located along the axis of the mountain and the Church, museum and crèche are all contained within the historic werf (DMP, 2011: 63).



Figure 12: Buildings in Pniël are generated from the axes of sightlines, historical response and landscape features.



Figure 13: Axis of Boschendal Homestead and Pniël



Figure 14: The spatial arrangement of Boschendal Homestead and the Town Square of Pniël

003 The Development of the Cape Dutch House

Cape Dutch homes belong to a family of long houses that have evolved from row houses. Early houses were single rooms with a large fireplace; screens later separated the private and the public spaces (Walton, 1965: 7). Later these screens became permanent walls separating the bedroom from the kitchen-living room. Thereafter the kitchen and the living room were separated (Walton, 1965: 7). As families grew, the long house was no longer adequate. This resulted in the emergence of the T-shaped plan.

The first step in the formation of the T-shaped plan was moving the kitchen to the rear end of the house. The entrance hall is located long the front of the building in the center and has bedrooms on either side (De Bosdari, 1964: 19). Doors behind the entrance hall led to a dining room and kitchen thereafter (Walton, 1965: 7).

As the need to host visitors and families grew even further, the need for more bedrooms became apparent. This resulted in the emergence of the H-shaped plan (Walton, 1965: 8). The 'H' shaped is thus made up of a central hall with the wings allocated as spaces for services and bedrooms (De Bosdari, 1964: 19). Courts are found on either side. These courtyards were often enclosed, paved or made into small gardens giving the appearance of a rectangular plan (Walton, 1965: 8).

The 'U' shaped plan has an internal courtyard to make the main reception room longer (De Bosdari, 1964: 19). Furthermore, combinations of these various types may also be found. Although the row house has evolved with time the various typologies appear to be strongly resistant to change (Rapoport: 1969: 4). When entering the interior space of the manor house one enters the voorkamer, a place for gathering. Just behind the voorkamer is the agterkamer, the dining room. The

voorkamer and agterkamer create a transitional internal threshold within the manor house and are found within the various typologies.



Figure 15: Typologies T, H, U

004 The Mission Village and Homesteads in the Dwars River Valley

Cape Dutch architecture embodies the built fabric of a mission town. An avenue of trees, a werf wall and the placement and relationships of buildings all create the character of the homestead (Walton, 1965: 39). Eminent homesteads within the Dwars River Valley include Boschendal, Rhone, Goedehoop and Bethalem. These homesteads constitute the various werf typologies found within this area.

The Manor house is placed with the most importance within the werf and additional buildings are positioned accordingly. Boschendal's H-shaped Manor house stands entirely on a raised platform (Picton, 1989: 58). The homestead has a tree-lined axial approach with an avenue werf (Fagan, 1994: 183). A screen separates the voorkamer and agterkamer; these rooms provide the central space for movement. Bedrooms are found directly off this central space with the kitchen positioned in the back end of the Manor house.

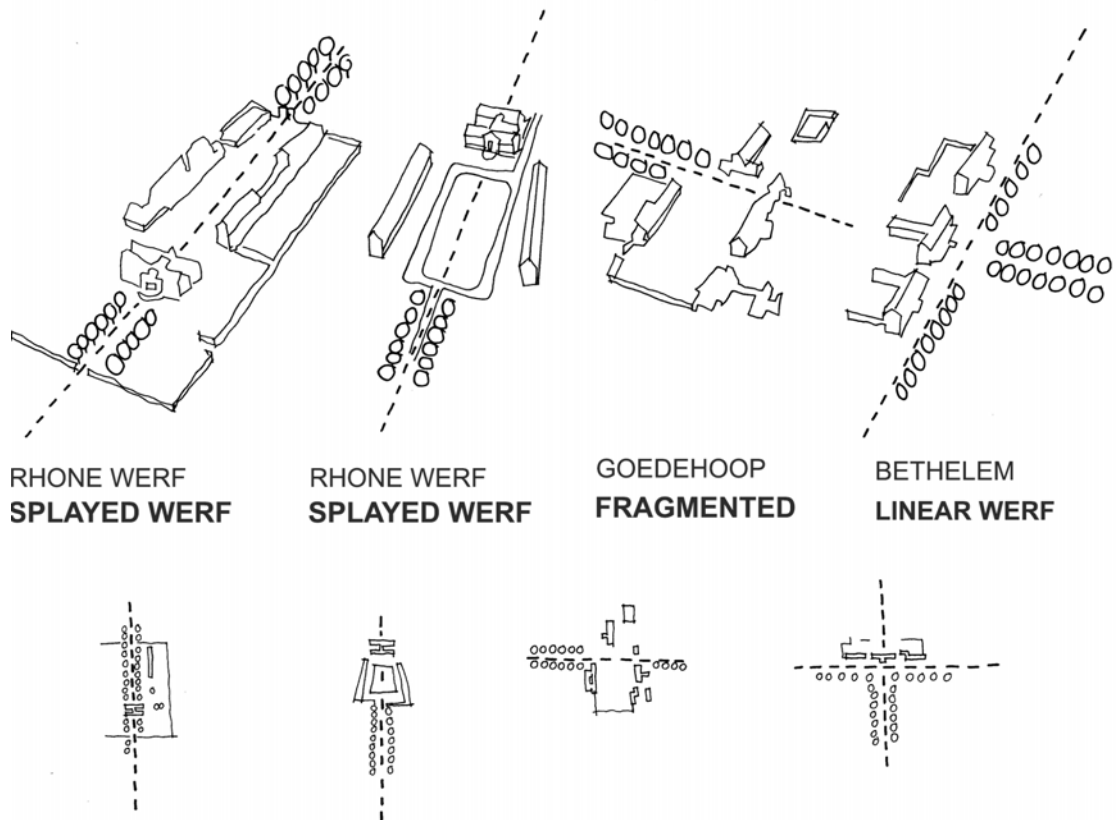

Figure 16: Werf Homesteads in the Dwars River Valley

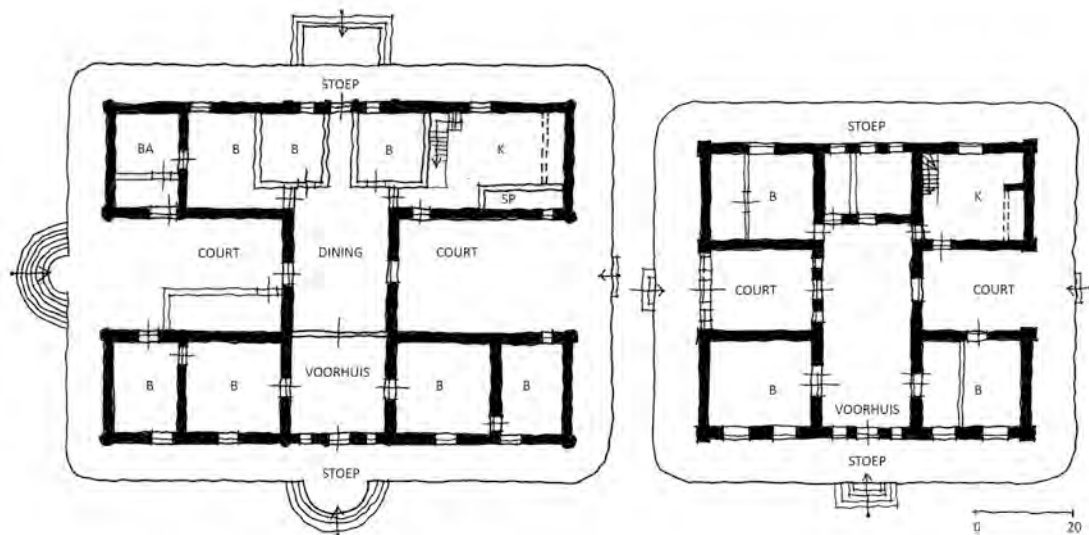

Figure 17: Boschendal Homestead and Rhone Homestead

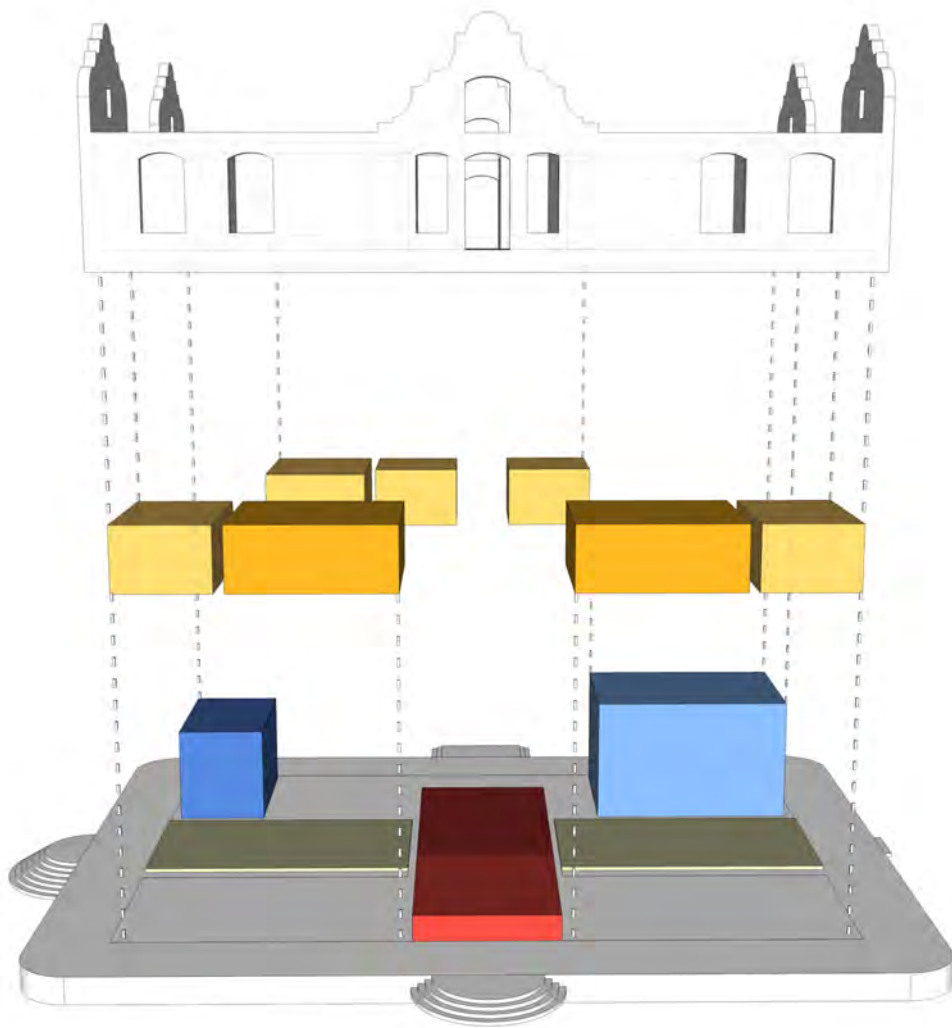

Figure 18: Axonometric view on the rooms within the Boschendal's homestead

005 Theoretical Approach

5.1 Roger Trancik

Roger Trancik explores lost space and the ideas around the redesigning of lost space. He identifies factors pertaining to the issue of lost space and discusses aspects that have eroded tradition. He argues that spatial design strategies should be implemented to define exterior space and act as a generator to express its existing context and buildings (Trancik, 1986: 18). Therefore, lost space needs to be re-established through key design principles in the context of the built environment in order to ensure sustainable urban development. Three urban spatial design theories are discussed, namely the figure ground theory, the linkage theory and the place theory.

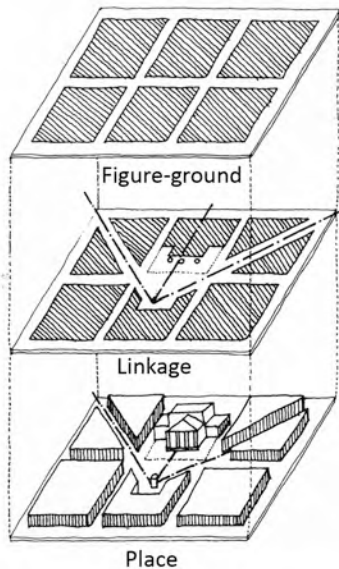

Figure 19: Urban Design Theory

The linkage theory speaks of a line connecting parts. It describes linear paths such as streets and pedestrian ways that form the linear path through a network of ordering systems. The figure ground theory considers the relations of building to void (Trancik, 1986: 97). It is found in the lost space that is defined as the leftover unstructured landscape; the open parking spaces; the forgotten space on the edges of roads and the unused spaces between public buildings (Trancik, 1986: 3). The place theory highlights elements that are inherent to the place; these may be explored through human needs, their culture, and their historical and natural context.

Trancik emphasizes the importance of responding to the historical context and its relationship to new design and existing conditions. Consequently, there is merit in

understanding the cultural and human characteristics of a physical place, and these principles can be viewed with the same importance as enclosure and linkage (Trancik, 1986: 112). Also, Trancik states that if the urban space is poorly defined, new buildings must be created (1986: 73). Strong spatial design policies must be implemented and the public should assist in establishing its environment. The new spatial design should define exterior space and act as a generator expressing existing context and buildings. People define and react to space through its enclosure and individuals enjoy structured spaces. Opportunities for development should be encouraged in lost and isolated space and that a sequence of outdoor rooms should be emphasized (Trancik, 1986: 19).

Large amounts of open space separate the civil building of Pniël, which provide an opportunity for these open spaces to be better defined as to encourage social activity. New buildings are positioned along an axis and placed within the square to contain the square. Locating buildings along strong axes form part of the elements that are inherent to Pniël and its context.

Traditional city form creates a workable link between buildings and open space and is designed in this manner (Trancik, 1986: 19). Street squares should once again become the spaces for social engagement. The square in a mission village serves as an important space for activity and it is important that this space be revived. Streets can be imagined as areas of positive exterior spaces that are rich in social activities (Trancik, 1986: 70). Hence, the main road of an area should provide a path along which all the civil buildings of this area are found. Additionally, spaces along a path that are poorly defined and lack density must be redefined.

5.2 Kevin Lynch

A mental mapping process of individuals traveling through a space is what interests Kevin Lynch (Trancik, 1986: 116). Lynch puts forward principles for designing city space, namely legibility, structure and identity, and imageability. The legibility refers to the mental picture of the city that individuals put together. Structure and identity always appear together in reality (Lynch, 1960: 8). The structure refers to the built fabric of the area while the identity can be expressed through its character. Furthermore, imageability refers to how the individual experiences the space. Lynch suggests that a successful city is one that uses these principles (Trancik, 1986: 120).

Key elements of the city, namely nodes, paths, edges, and districts that are needed as a set of organizational structures to define space says Lynch. These elements can be used to re-establish a mission village while redefining the path and place in the context of this investigation. Here, the path refers to the route along which the individuals would find themselves moving. And, edges are the boundaries that create a linear break along a path. These may be physical barriers or a change in edge condition or built fabric. Furthermore, a district can be seen as a space that an individual mentally enters with an easily identifiable character (Lynch, 1960: 47). Nodes are generally places of importance that may have a concentrated character within a focused space while landmarks are physical objects found within the area (Lynch, 1960: 47).

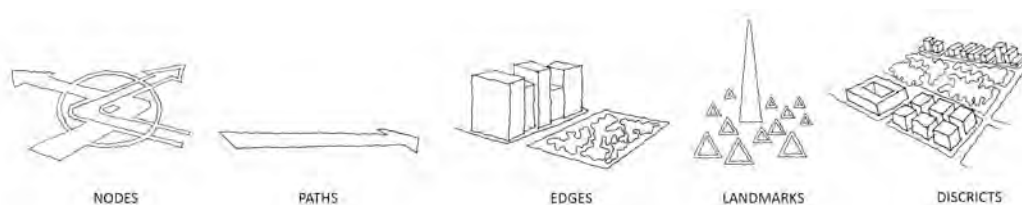

Figure 20: Lynch's Elements of the City

5.3 Gordon Cullen

Gordon Cullen discusses the art of relationships and suggests that the character and quality of settlements may improve if there is a better understanding of these spaces. He explains that the art of relationships acts as a connector, connecting elements such as buildings, trees, streets, squares, and public spaces to make up a positive urban environment (DMP, 2010: 40). For Cullen it is necessary to manipulate the elements in a place so that a sense of emotion is experienced (Cullen, 1971: 9). Activities and relationships between spaces need to be established to ensure the vibrancy of a space, as well as interaction between the path and the place of an area.

Serial vision is said by Cullen to be a powerful mechanism to evoke memories and experience of a place. The surrounding mountain ranges and built fabric of the Dwars River valley can serve to evoke memories and create an experiential journey through space and time. This may reveal new spaces as one interacts with a place, acting as a tool to provide interest to the individual along their journey (Cullen, 1971: 9). A long straight road has very little interest and contrast and the juxtaposition of elements will enable spaces to come alive (Cullen, 1971: 9). This should be encouraged in places that require vibrancy. Road signs and the surface ground treatment should assist in defining how people engage with the space when travelling through the space (Cullen, 1971: 96). Thus, open spaces must be filled with activities and objects that will encourage people to stream to and connect with the space (Cullen, 1971: 104). Subsequently, the social vibrancy of a space can only be established through the interaction of people with the landscape and activities that ensure this interaction be placed into these spaces.

The theory allows for an exploration of the fabric of this area through colour, texture, scale, style and character elements existing within the space, which altogether provide richness in the environment (Cullen, 1971: 12). Pniël's built fabric is rich in texture and character, and this provides the area with a distinct architectural quality. A sense of place connects 'our body to its environment' and the

relationship to our bodies and the environment therefore serves as an important tool when designing (Cullen, 1971: 10). Consequently, we need to understand how the people in an area experience the place, how the people passing through an area experience the place, and how these two worlds are able to collide and interact.

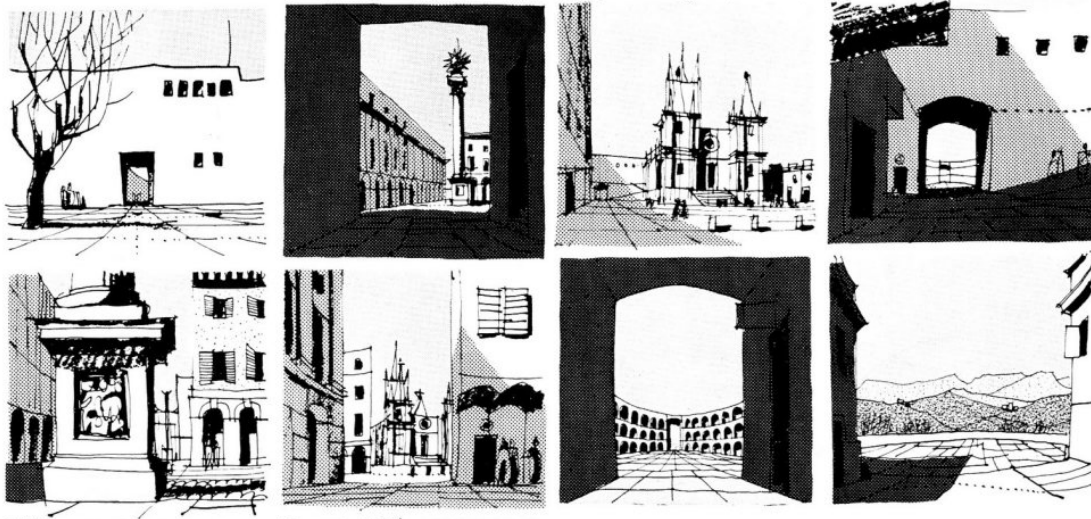

Figure 21: Sequence of Townscape

5.4 Norberg-Schulz

Genius loci refers to a spirit of the place (Norberg-Schulz, 1979: 18). Places with rich heritage and tradition often have a great spirit; but to experience the genius loci of the place one needs to engage with the place.

The essence of a place is qualitative with non-tangible things forming its character (Norberg-Schulz, 1979: 6). However to understand the genius loci we need to understand the meaning and structure of a place (Norberg-Schulz, 1979: 166). The meaning of objects refers to its relationship to other objects while structure refers to the formal properties of these relationships (Norberg-Schulz, 1979: 166).

Both the atmosphere and the concrete form make up the character of a place (Norberg-Schulz, 1979: 6). Place serves as a necessary part of existence as it refers

to locality and concrete things that exist in the world (Norberg-Schulz, 1979: 6). Furthermore, human identity forms the essence of ones sense of belonging and to belong to a concrete place (Norberg-Schulz, 1979: 22). The character of a place is ever changing through the changes in the built fabric, the landscape and the people. The atmosphere and the character serve as key elements in reviving the spirit of the place.

Norberg-Schulz states that to revive a sense of place is to create meaning, identity and establish it in history. In essence, to respect the genius loci of a space means to respect the identity of a place (1979: 182). This can be done by reinterpreting the existing in a new light that results in progress and relevancy of a place. (Norberg-Schulz, 1979: 182).

006 Urban Strategy

There is a human need to create a sense of place and identity. Establishing buildings that provide a sense of place and identity enables people to connect to the landscape (Cullen, 1971: 12). Subsequently, providing a community with a space that promotes social engagement may assist in strengthening community relationships. Creating a building that acknowledges the contribution of its people and encourages community participation may strengthen the pride within an area.

Transformation and empowerment is possible through skills development and training. The making of a building that aids community members to establish art careers, teaching them the skill of business, computers and ceramics is proposed within the square.

A Cultural Tourist Information Center within the town square can allow individuals to engage with the cultural activities of Pniël while learning about the area. Individual's passing through Pniël should be encouraged to stop along the path and experience the activities that can allow for a vibrant social environment. Community members will add to the vibrancy of the space by assisting in the making of ceramic components while facilitating an environment that welcomes tourist.

The ground floor of this building will offer a place for public activity while the first floor is largely focused on spaces for learning. The kiln and studio is the heart of this building. Ceramics can be produced in the studio space and fired in the kiln. Visitors will be able to visit the studio space and learn about the process and making of ceramics.

A farm shop will facilitate the sales of ceramic goods and fresh produce. Visitors will be able to enjoy traditional food in the eatery. The eatery will be located within an interior box in the building. Its social environment will spill out to the exterior of this building and be contained with a low werf wall. The low werf wall will further extend

towards the square. Open spaces within the square can allow for outdoor public activities. An amphitheater provides a space for future concerts or social events.

A vegetable garden located adjacent to the museum will allow for a space that enables people to walk through the garden. Also the produce from this vegetable garden will be sold in the eatery and farm shop.

Within the interior, boxes can contain space for significant activity. The information area, waiting/ meeting room, farm shop, eatery and places for learning are placed within these boxes. The gallery space is made up of the open space around these boxes and people are able to meander through these spaces.

Thick walls contain the services of the building. The kitchen, bathrooms and staircases are placed within these walls. Placing services within the walls free the interior space, so spatial boxes of activity within the interior are given a sense of importance within the interior and can be better celebrated.

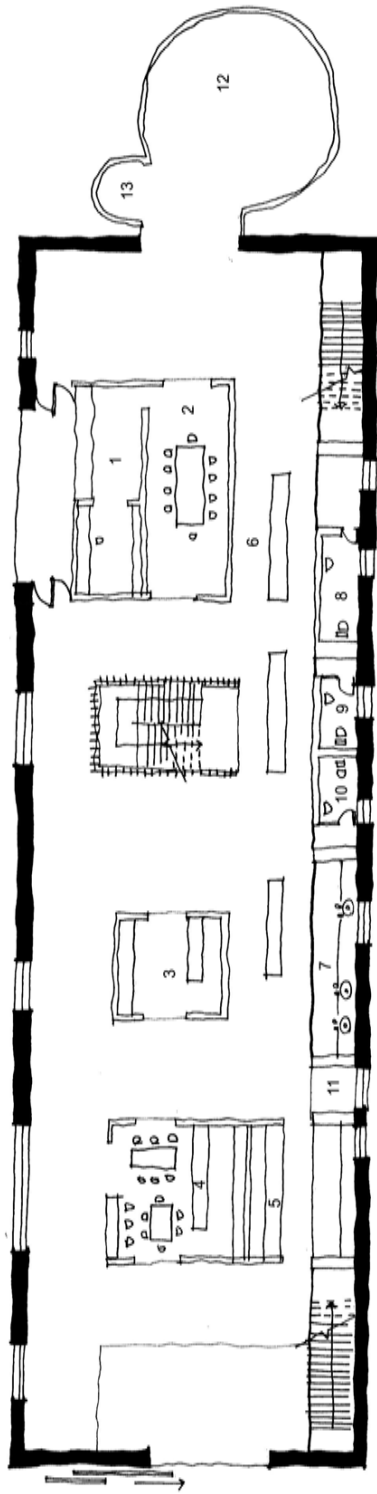

- 1. Voorkamer/Information
- 2. Agterkamer/ Seating Area
- 3. Farm Shop
- 4. Eatery
- 5. Kitchen
- 6. Gallery Space
- 7. Seating
- 8. Disabled WC
- 9. Female WC
- 10. Male WC
- 11. Lift
- 12. Studio Space
- 13. Kiln Room

Figure 22: Ground Floor.

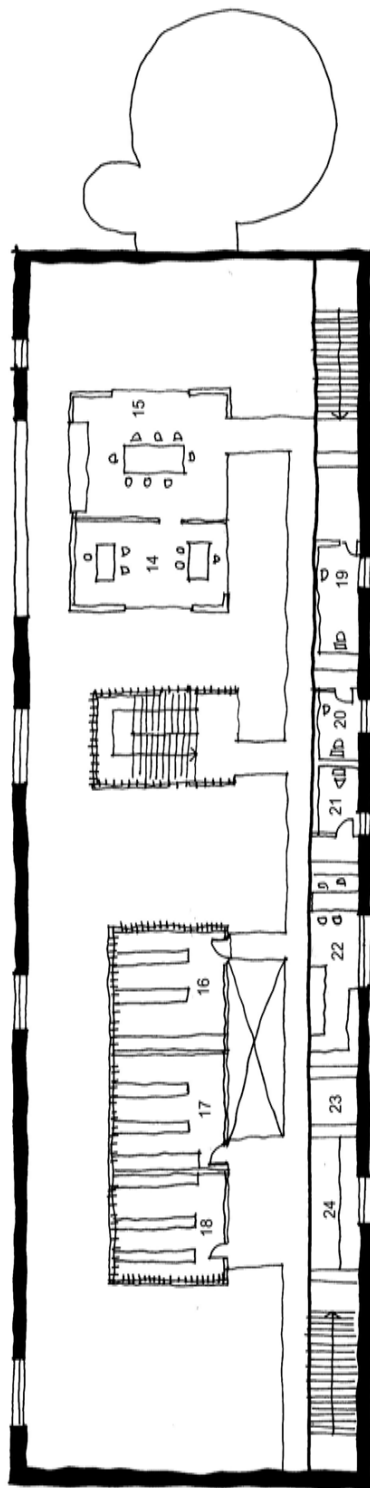

- 14. Office 1
- 15. Seating Area
- 16. Classroom 1
- 17. Classroom 2
- 18. Computer Room
- 19. Disabled WC
- 20. Female WC
- 21. Male WC
- 22. Resource Centre
- 23. Lift
- 24. Kitchenette

Figure 23: First Floor

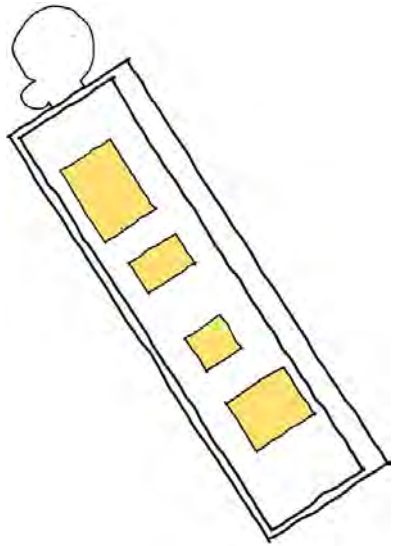

Ground Floor

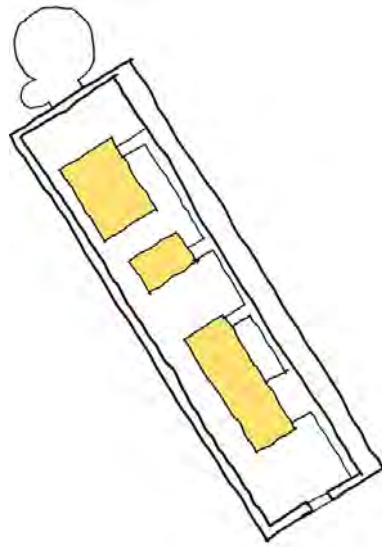

First Floor

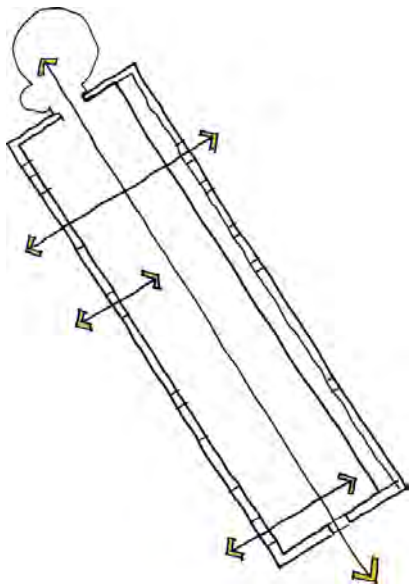

Visual Axis

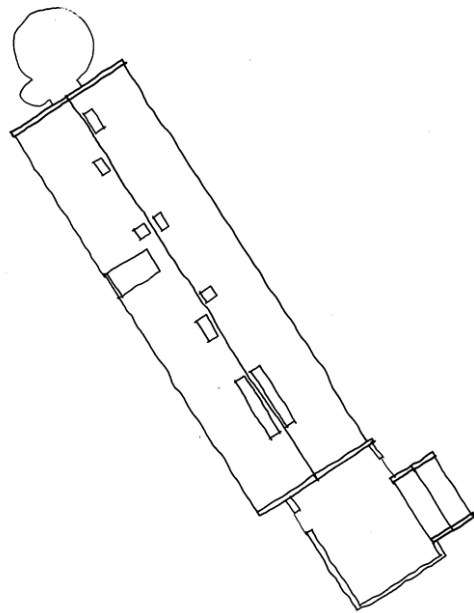

Roof

Figure 24: Spatial Arrangement

6.1 Spatial Arrangement

Within Cape Dutch Architecture there is importance around the entrance of the homestead. The entrance of the proposed building has a large opening that draws people towards the foyer and information area. Much like the homestead, the information area and foyer space act as the voorkamer. The meeting room has a large boardroom table; this is similar to the agterkamer that has a dining room table that provides a space to gather around.

Rooms are separate spaces of activity and are placed according to its function. The interior boxes are perceived to be sacred spaces of celebration. Openings within these boxes enable individuals to perceive the elements contained within each box while being able to see through the entirety of the building when standing along the center of the box. This reinforced the ideas of the avenue and linear approach characterized by Cape Dutch Architecture.

The eatery is an area of social activity and these activities extend towards the exterior of the building. An outdoor seating area contained with a low werf wall contains this space. Low werf walls also contain the crèche and museum.

The central staircase stands between the foyer space and the farm shop and is the only box that spans over two levels. Its primary structure is made up of a steel structure clad with timber. The timber structure holds the ceramic components in place. Ceramic components are gradually added to this framework ensuring the making of a vibrant space and signifying the contribution of the people to the areas built environment. Ceramics produced in the studio space are sold in the farm shop. Other ceramic pieces are also displayed along the gallery walls of the building.

The openings of the windows are positioned to reveal the various activities within each of the boxes. Windows that open are covered with shutters and windows that

reveal spaces within are left to do so. Similar to the manor house, the front entrance is the only opening along the buildings front façade that touches the floor.

Skylights filter light into the interior boxes. Ramps are used to access these boxes of the first floor. There is a clear separation between the external structure and the internal structure. The external structure appears to be heavy while the internal structure has a lighter appearance. The rammed earth symbolizes the use of tradition building material while the use of ceramics expresses the progression of earth material in a contemporary manner

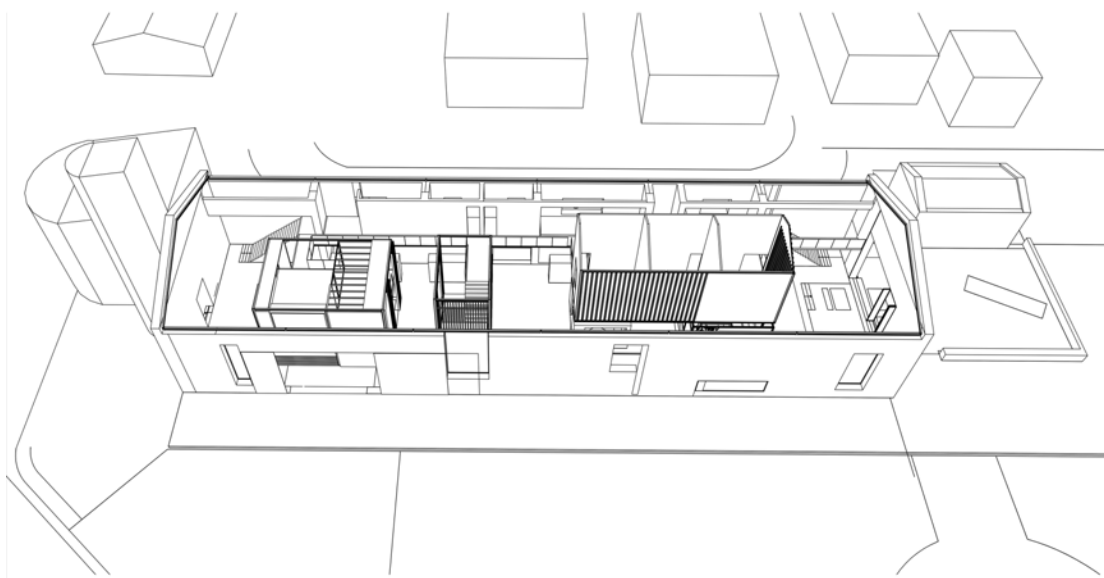

Figure 25: View of internal spatial arrangement

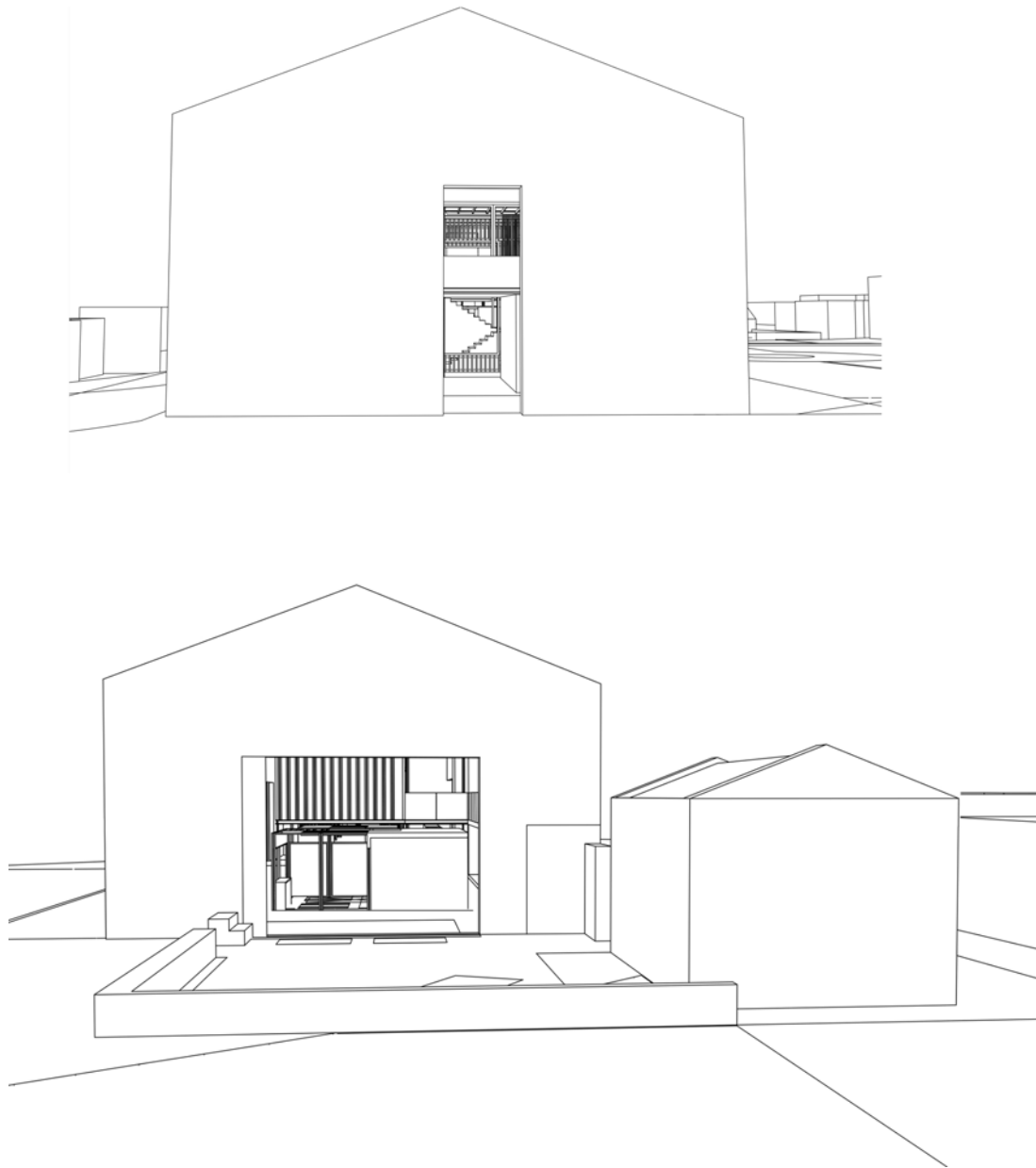

Figure 6: Views through boxes

6.2 Design Development

Plans demonstrate the special arrangement of the first floor and the ground floor. There is juxtaposition between the heavy exterior walls and the lighter interior walls. The exterior walls are characterized by traditional earth construction while the interior boxes illustrates the progression of an earth material.

The entrance of this building has a large opening that frames the foyer space beyond. Similar to Cape Dutch architecture, it is the only opening along the front that touches the ground. Windows along the façade reveals the character of the internal environment of the building.

The corners of the interior boxes are always revealed. Door and other elements attached to the corners of these boxes are moved back. The ceilings of the single volume boxes never touch the underside of the floor above, giving the illusion that the box above are floating.

The spatial arrangement of the interior is similar to that of the homestead. Services are positioned along the back end of the building. There is strong ideas regarding linear movement and creating rooms.

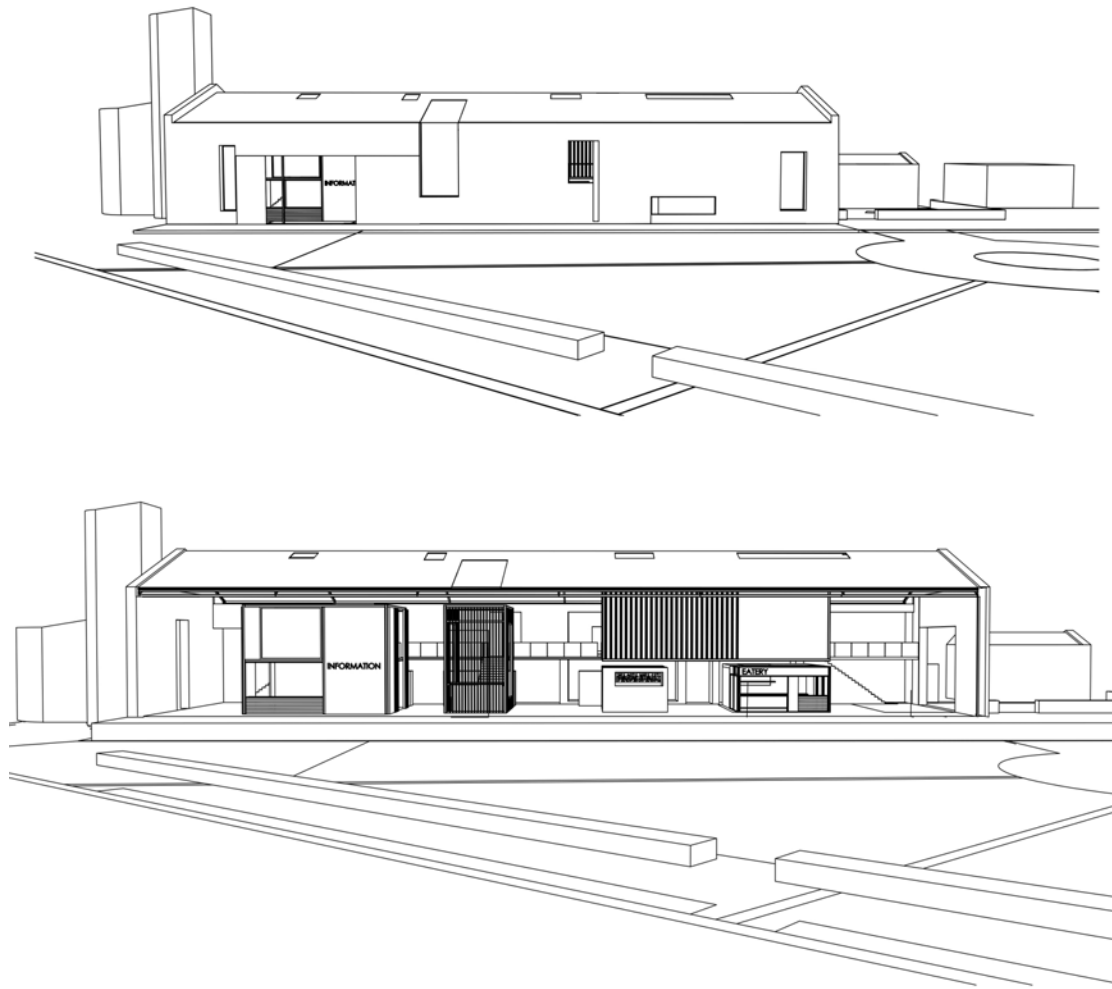

Figure 27: Building Façade

007 Using Elements of Cape Dutch Architecture to contain the Square

Principles of Cape Dutch Architecture and placemaking are applied in the making of this building and its urban environment. Elements of Cape Dutch Architecture namely, the werf wall, raised platform, the exterior walls, interior space and the kitchen are discussed. All these elements contribute towards the making of a favourable town square. Additionally, on a building scale, the idea of the square is explored in the making of ceramics.

There is a relationship between material culture and social structure; this is expressed in the social life and identity of people (Brink, 2008: 17). Individuals express how they would like to be perceived through the use of material culture (Lucas, 2006: 17). Architecture and artifacts is an expression of the material culture of a society (Lucas, 2006: 17). Domestic architecture is the most prominent feature of material culture in the Dwars River Valley and is strongly influenced by European vernacular (Brink, 2008: 21). Gable ends, raised platforms, plastered benches, shutters and symmetrical windows characterize Cape Dutch vernacular.

With the arrival of the Dutch came the influence of Dutch material culture. Ceramics is an element of material culture that has been influenced by the Dutch (Lucas, 2006: 25).

7.1 Elements of Cape Dutch Architecture

The Werf

The werf wall is a prominent feature of Cape Dutch architecture. Low walls contain the buildings in the homestead. In the context of this urban strategy, buildings are positioned within the werf to contain the square. Associated activities connect adjacent buildings.

Raised Platform/Stoep

A raised platform is found along the front or perimeter of the building. The stoep is seen as a social space and is associated with activities of gathering and social interaction. It is perceived as a space strongly rooted in tradition (Walton, 1965: 6). Its raised platform protects the outside walls, creating an even surface for the placement of the buildings (Vosloo, 2010: 47).

In the context of the Square and the built environment, the raised platform is found along the front edge of the building. This stoep offers a space that enables activities within the building to extend outwards. These social activities are then able to further extend towards the square.

The Walls

Early buildings were first constructed using mud and straw; these mud-constructed houses were then painted with lime and whitewash to ensure that they remained waterproof (Walton, 1965: 6). The building's walls are thick and made of rammed earth, expressing the rough sophistication of Cape Dutch architecture (Picton, 1989: 58). Within the context of the proposed building, services are hidden within the thick walls, freeing up the internal space. The internal walls are freestanding, lightweight and semi transparent.

Early Cape Dutch houses were single rooms. Later internal structures separated the interior spaces, creating rooms within rooms. Internal rooms within the proposed building are characterized as sacred celebratory spaces. As such, they are positioned with importance in the building, never touching the exterior walls.

Voorkamer & Agterkamer

The voorkamer can be described as the gathering space of the house. Its beauty lies in its simplicity and use of materials. Doors located behind the voorkamer lead to the agterkamer, the dining room (Walton, 1965: 24). The voorkamer and agterkamer mark the transitional internal threshold in the manor house.

The information desk and foyer area receives the guests and acts as the voorkamer of this building. The spaces around the rooms serve as gallery space displaying artwork. The rooms extend into the building and the building extends into the space. This creates rooms within rooms at a building scale as well as an urban scale.

The Heart of the House

The kitchen provides a source of tradition and warmth to the manor house (Walton, 1965: 34). It offers a space where traditional family recipes were handed down and served as a source of warmth during the winter periods (Walton, 1965: 28).

The proposed buildings' kiln and studio space is located on the end of the building nearest to the road. This space acts as a node and people travelling along the path are greeted by a tall structure made from adobe bricks. The kiln and studio space are formed by two separate kiln like structures. The smaller structure is the firing room while the studio space is the larger brick structure. This studio space aids in the making of social vibrancy and economic development.

008 Technology

Traditional construction methods are used in the making of the buildings external walls. External walls are made from thick rammed earth. Ceramic components are found within the interior of this building. Advances in technology have ensured the progression of clay as a material within the built environment. Ceramics enables the making of a contemporary building component with the use of a traditional earth material.

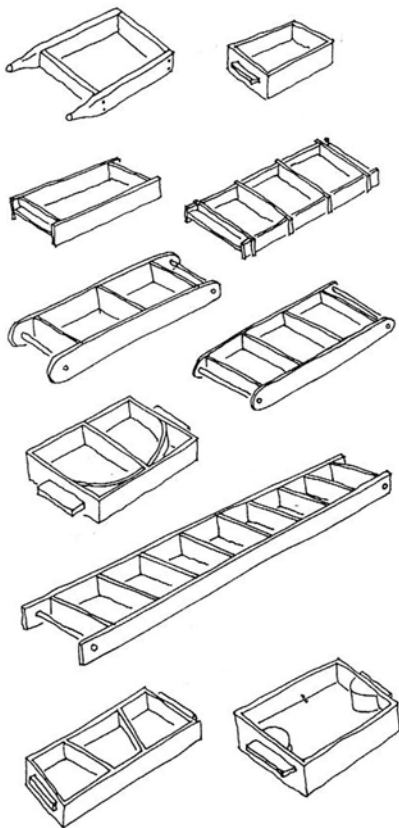

Figure 29: Adobe brick molds

8. 1 Mud (Adobe) Bricks

Adobe bricks are a modular masonry mud brick that is sun dried and can be made using molds (Minke, 2006: 3). The material is placed in timber molds and left to dry; this process takes roughly seven days in favorable weather conditions (McHenry, 1984: 66). A desirable size for an adobe/clay brick is 200 x 200 x 50mm or 200 x 100 x 50mm (Khalili, 1986: 81)

Adobe bricks' durability can easily be tested, as individual bricks are able to undergo press tests (Norton, 1997: 38).

These bricks are brittle when wet and consequently need to be adequately cured

when worked with. Kiln firing is also possible with adobe bricks. This ensures that the material has added strength and durability and remains water-resistant (McHenry, 1984: 76).

The kiln-like structures are made from adobe brick. The juxtaposition between the bricks and the rammed earth gives the building a rich texture from the outside.

8. 2 Rammed Earth

Both adobe and rammed earth uses unfired earth. The material is considered to be a low-cost, sustainable building material (Ching, 1943: 5.31). The soil used to manufacture earth structures is readily available as the soil found on site is usually adequate for the production of adobe bricks (McHenry, 1984: 58).

Rammed earth is made up of aggregate, sand, silt, and clay and uses formwork to secure the placement of the damp earth (McHenry, 1984: 97). Timber planks of approximately 2000 - 3000mm long and 900mm high provides the formwork, holding this material in place while curing (Keefe, 2005: 86). Due to its low tensile strength, loads cannot be placed on the earth structure until it is fully cured (Ching, 1943: 5.32). The optimal wall thickness for a rammed earth wall is no less than 250mm and no more than 600mm (McHenry, 1984: 97). The outside walls of this building will be 600mm thick.

The first Cape Dutch buildings were built with timber-framed structures. These structures were then concealed with earth (Pearse, 1968: 7). The timber-framed structure consists of vertical and horizontal members. Wet loam comprised of straw, twigs, branches and mud formed the earth substrate (Minke, 2006: 80). Cement, lime or oil based products may be added to the material composition of rammed earth to lessen the effects of moisture. Early Cape Dutch buildings were sealed with lime to ensure they remained waterproof (Pearse, 1968:7).

The placement of horizontal reinforcement ensures the structural stability of the wall (McHenry, 1984: 105). Concrete beams are reinforced with steel to provide a desirable framework for the placement of rammed earth (McHenry, 1984: 105). Lime

substrate is used to ensure that the earth walls remain waterproof (Keefe, 2005:100). The framework for the external wall of this building makes use of concrete beams reinforced with steel. These openings will then be concealed with 600mm thick rammed earth.

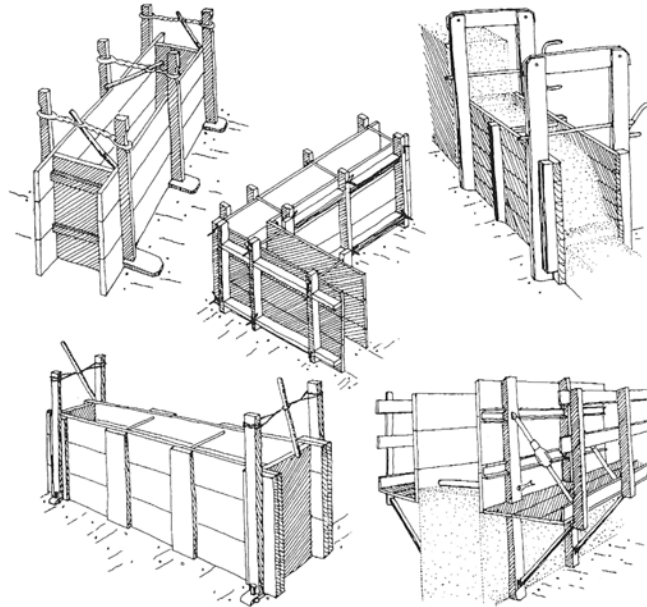

Figure 30: Typical framework constructed to contain rammed earth.

8.3 Clay

Clay as a building component can be seen as a material reminiscent of a historic building tradition and can provide a useful dialogue between the past and the present. Traditional materials may be re-used in the making of a contemporary building component, creating a connection between the past and the present. Furthermore, the use of clay within the built environment can encourage the development of an area. Also, the reinterpretation of tradition materials may assist in locating a building in time, providing it with a sense of place, adding to the material culture of the place. Ceramics can therefore be used as a suitable material to revive heritage and tradition while creating economic development. Furthermore it encourages the people passing through the place to engage with its activities. Ceramics has the ability to express itself through diverse colours and textures. These

colours and textures can be seen as the expression of the re-establishment of Pniel's vibrancy.

Clay can be used as a building material, a component and a surface treatment and can provide a sense of enclosure or to define space (Cullen, 1971: 32). Ceramics can be used to both contain and reveal space (Cullen, 1971: 32). Components will be made by the people within the community and will contribute to the vibrancy of the building and the cultural identity of the people.

Although the material composition of rammed earth may vary from that of clay, both these material are sourced directly from the earth.

8. 4 Foundations

Earth wall foundations require the same principles as other foundations. Earth walls are heavier than conventional walls. The structural load should therefore be taken into account when determining the thickness of the foundation (McHenry, 1984: 137). Reinforced steel concrete foundations offer a suitable foundation for earth walls. Foundations should be raised above the ground level to ensure that the earth wall does not experience long-term exposure to moisture

009 The making of Ceramic Components

Precedent Study

Half Square is a venture facilitated by the Spier Architectural Arts Programme and aids artist is establishing successful art careers. The Spier architectural Arts Programme focuses on creating an environment that educates community members primarily in the art of ceramics. The Half Square project is a successful ceramic project that uses right-angled ceramic tiles to create a vibrant mosaic walls. Right-angled ceramic tiles are glazed in a range of different colours. Two right-angled triangles essential make a square and it is this concept that drew to to this precedent (SpierArchitecturalArts, 2011)

“The Spier Arts Programme is a social program that aids artists in establishing successful art careers. Yellowwoods Art forms part of the Spier Arts Programme and was founded by Jeanette Blignaut Art Consultancy and Spier Art Trust.

The program specializes in fine arts, experimental and collaborative work ensures that individuals are encouraged through mentoring and exploration. Fine artists and architects collaborate to produce creative mosaic and ceramic pieces with apprentices aiding in the making of these pieces.

A three-year employment-based training provides individuals with theoretical lectures in business; mathematics; computer skills; art history; ceramic theory and ceramic educated and provided with employment, earning monthly salaries as apprentices.

Ceramics are developed along a production line. Products are developed to be as technically sound as possible; marketing is done thereafter to ensure that there is a global demand for the production line. Apprentices are taught to manage these

production lines subsequently providing them with the skills to run a successful studio" (SpierArchitecturalArts, 2011).

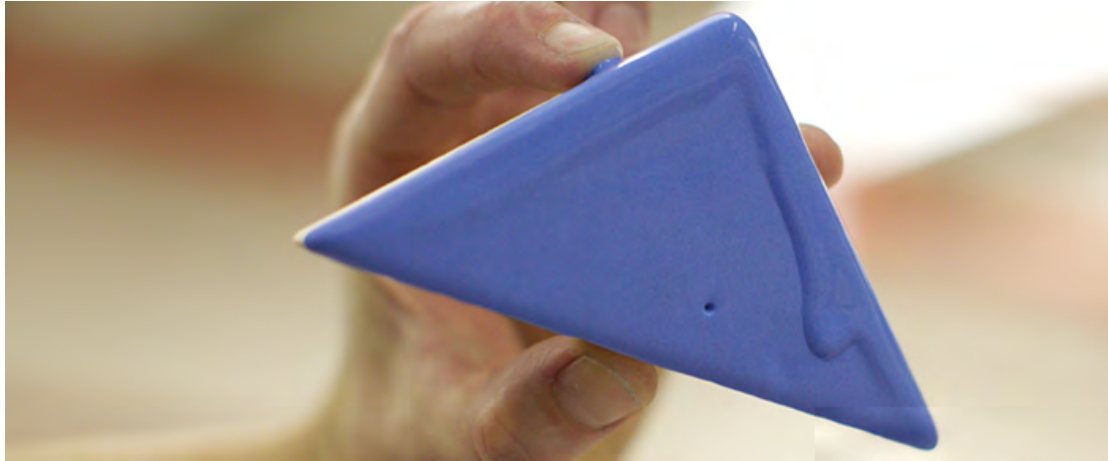

Figure 31: Ceramic tiles dipped in a glaze & ready to be fired. 2011

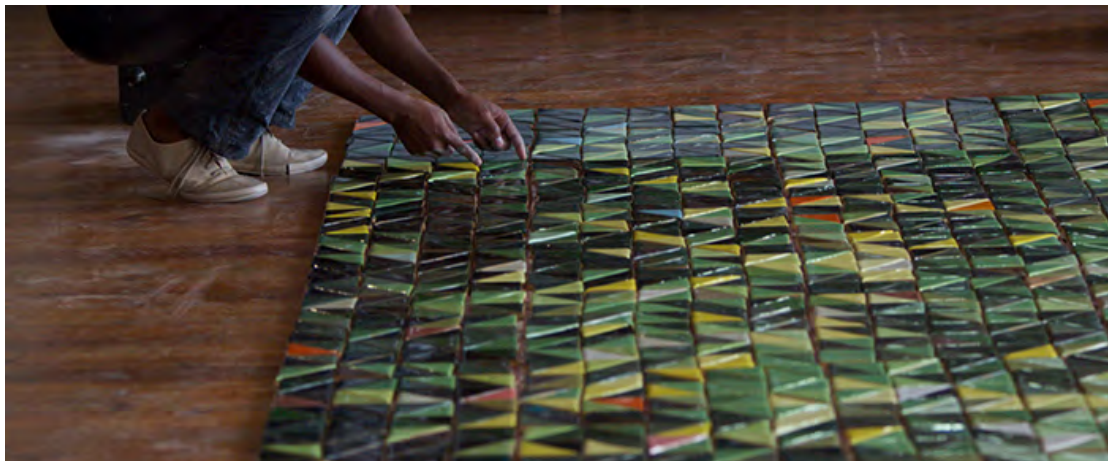

Figure 32: Spier Architectural Arts Programme. 2011

The Square Redefined

Le Corbusier also discusses ideas around redefining the square. Ideas on harmony and proportion are investigated in Le Corbusier's modular theory; he divides a square according to this theory (Macus, 2008).

So, encouraged by the need to redefine the town square, I was inspired to deconstruct a square. This led to the exploration and making of ceramic tiles and components. Ceramic tiles are divided proportionally to create a range of shapes within the constraints of a square.

Clay slabs were rolled and later cut into the desired forms. Traditional ceramic tools were used to make these ceramic components. Visualizing 2D objects as 3D components facilitated a point of departure for the making of these components. A square divided into two right angle triangles can be folded creating a folded plane. Ceramic components were constrained to fit within a module structure.

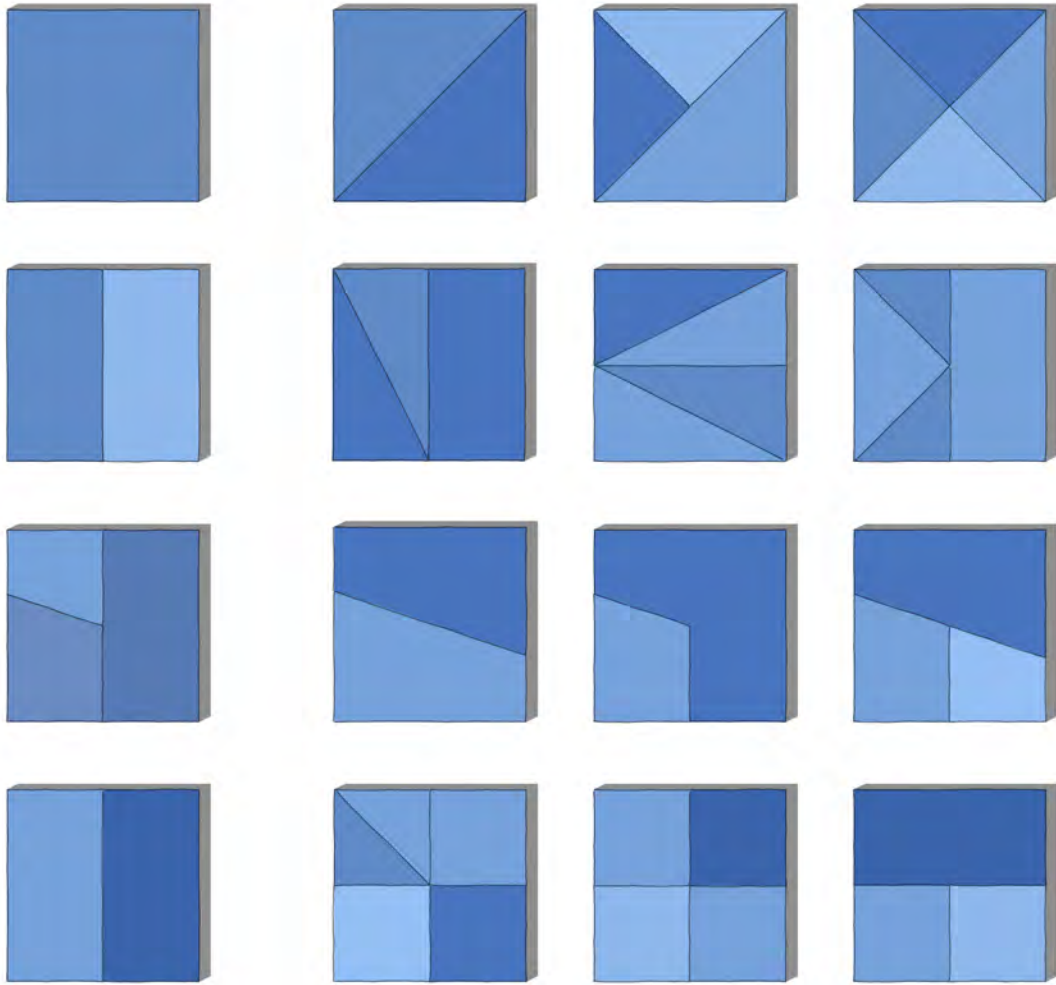

Figure 32: Ceramic Tiles are proportionally divided



Figure 33: Redefining the Square to create a 3D Component

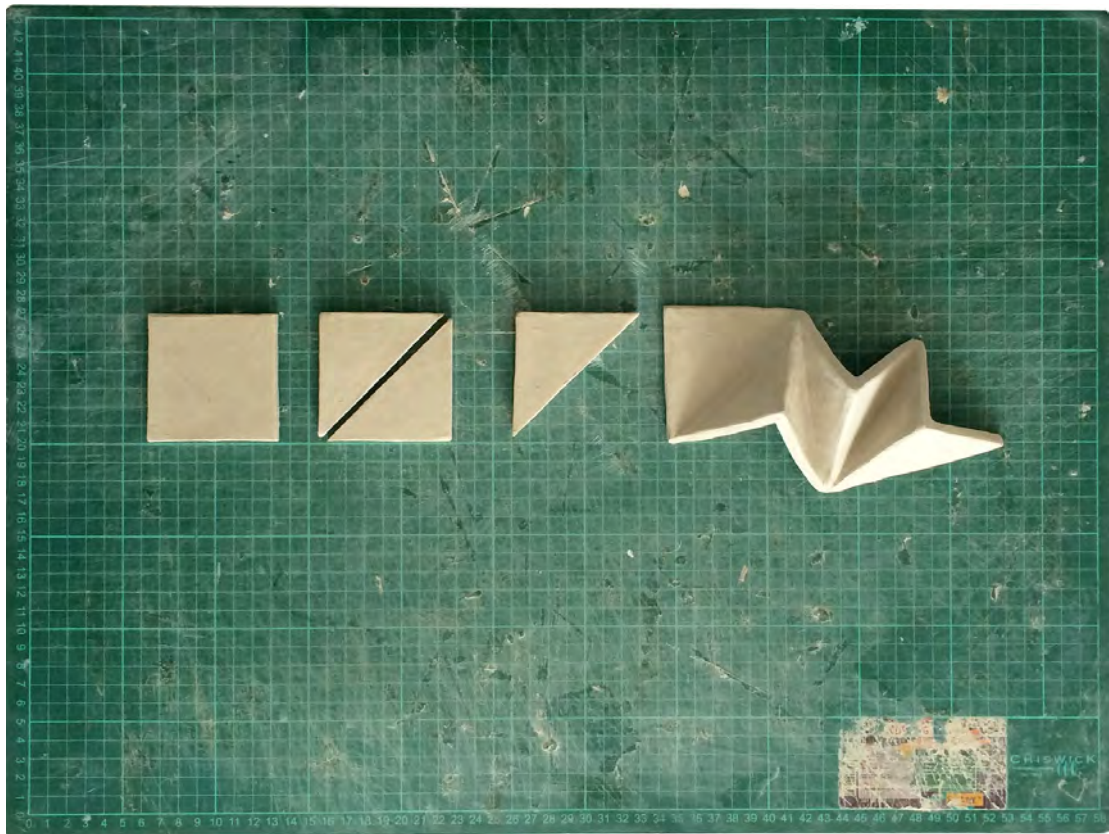

Figure 35: Redefining the Square to create a 3D Component



Figure 36: Investigative studies exploring the placement of ceramic components alongside each other. Openings allow light to filter though the object.



Figure 37: Investigative studies exploring the placement of ceramic components.

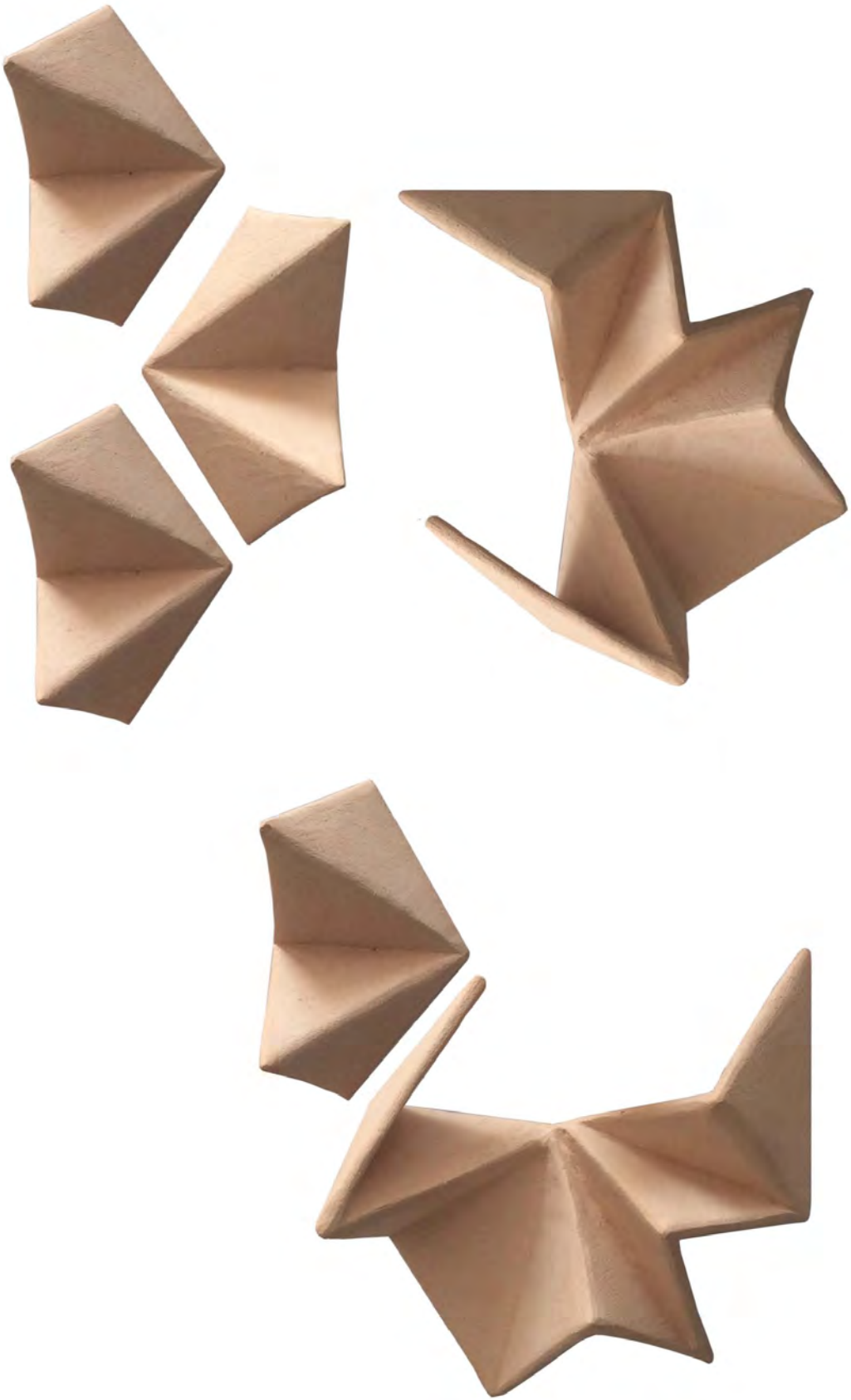

Figure 38: Exploratory studies illustrating unglazed fired clay (Bisque Ware)

010 Final Thoughts

Given this disconnect between the path and the place the above theories may assist in re-imagining vibrancy and boundaries. It is essential that the essence of the place not be lost and that the identity of a place be respected. New buildings need to respect the building typologies that exist within an area.

The culture, history, heritage and richness of the landscape and its people need to be celebrated. And for this to happen, we need to safeguard and improve mission villages through socio-economic development and empowerment initiatives. However there needs to be a connection between path and place as this may assist in ensuring the future success of an area. There is value in responding to the historical context of an area and designing in a manner that respects the existing buildings and typography.

The square in a mission villages serves, as an important space for activity and it is important that this space be revived. Activating the square through economic and social activity may create vibrancy in Pniël and assist in the future success and sustainability of this area. The character of the place needs to be celebrated however one needs to engage with place to experience the genius loci. Large amounts of open spaces in the square needs to be redefined, these spaces should be activated and encourage social engagement. Activating spaces and encouraging social engagement will encourage people to stop along the path.

Clay may be used as a building component to create a vibrant space within the built environment enriching the cultural landscape of the place. Tradition building materials may be used to assist in locating a building in time as it speaks of the inherent historical qualities of an area. Clay as a building component may thus be used as a means to re-establish the cultural vibrancy of a place.

011 Bibliography

BRINK, Y. 2008. *They came to stay: Discovering meaning in the 18th Century country dwelling*. Stellenbosch: African Sun Media

CULLEN, G. 1971. *The Concise Townscape*. Oxford; Architectural Press

CHING, F. 1943. *Buildings Construction Illustrated – Fourth Edition*. America: John Wiley & Sons, Inc.

DMP (DENNIS MOSS PARTNERSHIP). 15 December 2010. *Boschendal Sustainable Development Initiative (SDI) Phase 2 proposals*

FAGAN, G. 1994. *An introduction to an-made landscapes at the Cape from the 17th to the 19th centuries*. Cape Town: University of Cape Town
(thesis doc check refererancing)

FRANSEN, H. 2006. *Old Towns and Villages of the Cape*. Jappestown: Jonathan Ball Publishers

KHALILI, N. 1986. *Ceramic Houses & Earth Architecture*. America: Harper & Row.

KREEFE, L. 2005. *Earth Buildings: Methods and Materials, Repair and Conservation*. London and New York: Taylor & Francis

NORTAN, J. 1997. *Building with Earth*. London: Publications Limited

MC HENRY, P.G Jr. 1984. *Adobe and rammed Earth Buildings*. Canada: Wiley

MINKE, G. 2006. *Building with Earth: Design and Technology of a Sustainable Architecture*. Switzerland: Birkhauser

LUCAS, G. 2006. *An Archaeology of Colonial Identity: The Power of Material Culture in the Dwars River Valley, South Africa*. America: Springer Science & Business Media, Inc

PEARSE, G. 1968. *Eighteenth century architecture in South Africa*. Third edition. Cape Town: Balkema

PICTON - SEYMOUR, D. 1989. *Historical Buildings in South Africa*. Cape Town: Struikhof Publishers

RYKWERT, J. 1976. *The Idea of a Town: The Anthropology of Urban Form in Rome, Italy and the Ancient World*. London: Faber and Faber Limited

VAN DER WAAL, K. 2014. *Transformation in the Dwars River Valley*. Pietermaritzburg: University of KwaZulu-Natal Press

VOSLOO, C. 2010. *Towards Local Identity in South African Architecture*. South Africa: University of Johannesburg

WALTON, J. 1965. *Homesteads and Villages in South Africa*. Pretoria: J. L. Van Schaik LTD

ZUMTHOR, P. 1998 *Thinking Architecture*. Baden: Lars Muller Publisher

Spier Architectural Arts, 2011, *About Us*. Cape Town.

<http://spierarchitecturalarts.co.za> [June 2015]

DAVIES, M, 2008, 'Sublime' 25 years of Marcus Davies. London. <http://marcusdaviesphotography.com>.