

The copyright of this thesis vests in the author. No quotation from it or information derived from it is to be published without full acknowledgement of the source. The thesis is to be used for private study or non-commercial research purposes only.

Published by the University of Cape Town (UCT) in terms of the non-exclusive license granted to UCT by the author.

## Abstract

In South Africa, many wastewater treatment plants (WWTP) still make use of their rock filled trickling filters. Instead of using them for organics removal and nitrification, there is growing interest in integrating them with biological excess P removal activated sludge (BEPRAS) systems in an external nitrification flow scheme (Hu et al., 2000). In such a scheme, the full influent flow (after primary settling) is discharged to the anaerobic reactor of the BEPRAS system, after which the activated sludge is separated from the water by internal settling tanks. The clarified supernatant is pumped to the trickling filter for nitrification and the activated sludge to the anoxic reactor of the BEPRAS system, where the nitrified water rejoins the main BEPRAS system. This external nitrification BEPRAS system has several advantages over continuing to use the trickling filters for organics removal and nitrification, such as significantly reduced oxygen demand (~50%) and biological N and P removal on the full wastewater flow. To date full-scale studies in South Africa have been performed only with rock media trickling filters, for example that at Daspoort WWTP (Muller et al., 2004, 2006a, b).

This report describes an investigation on the full-scale operation of a plastic media nitrifying trickling filter (NTF) at the 1 Ml/d Citrusdal WWTP. This WWTP comprises a 4.2 day retention time lagoon with aeration only in the first half to allow for solids settlement in the second half. The lagoon effluent from the end of the settling zone is pumped to a plastic media NTF unit in order to meet standard effluent ammonia concentration requirements of  $< 3.0 \text{ mgN/l}$ . The dimensions of the plastic media are 5.5m wide, 5.5m long and 5.4m high and has a specific surface of  $142 \text{ m}^2/\text{m}^3$ , yielding a total media surface ( $A_t$ ) of  $23\,100 \text{ m}^2$  in the tower. The wastewater is distributed over the NTF media through ~100 garden spray nozzles suspended above the media. After a single pass (recirculation was added during this investigation) the NTF effluent is discharged to a series of five maturation ponds and used for irrigating the golf course in summer, and or discharged to the Olifants River.

Maximum apparent ammonia nitrification rates (ApANRs) of  $1.00 \text{ gN/m}^2\text{d}$  were achieved during the full scale investigation when all recirculation pumps and ventilation fans were operating and the effluent free and saline ammonia (FSA) concentration was above  $5 \text{ mgN/L}$ . This was equivalent to an ammonia removal efficiency of approximately 85% of the influent ammonia concentration, or an ammonia concentration removal of  $24.1 \text{ mgN/L}$  or a mass removal of  $23.1 \text{ kgN/d}$ .

Hydraulic loading rates (HLRs) greater than  $2.0 \text{ m/hr}$  were found to significantly improve nitrification rates at full-scale investigation. ApANRs declined during the winter period, under poor ventilation even when HLRs were greater than  $2.0 \text{ m/hr}$ . There was minimal soluble organics removal exhibited by the NTF. However, significant particulate organics removal was observed during the summer period. This attributed to the non uniform distribution of water over the media, as particulates lead to clogging of the media. This conclusion was corroborated by irregular flow patterns observed through some of the sampling ports of the NTF (there are four sampling ports on all the four faces of the square TF which

are equally spaced). The profile samples (taken from the sampling ports) had significant traces of motile algae through out the investigation.

A laboratory scale investigation which was not a replica of the full-scale NTF was also carried out. This NTF with a cross sectional area of 0.021 m<sup>2</sup> and was filled with round spherical plastic balls, similar to rock media, with a specific surface ratio of 109 m<sup>2</sup>/m<sup>3</sup> (total media surface area of 3.34 m<sup>2</sup>). The NTF was loaded with wastewater that had virtually zero suspended solids and the average soluble influent COD concentration was 56 mgCOD/l. The organic removal rates by the NTF was negligible. Maximum ApANRs of 1.72 gN/d per m<sup>2</sup> media surface were achieved, under hydraulic loading rates of 0.86 m/h. This is equivalent to a removal efficiency of approximately 73% resulting in an ammonia concentration removal of 28.6 mgN/L or a mass removal of 5.76 gN/d. Under laboratory conditions, the NTF was also found to be sensitive to hydraulic loading rates.

University of Cape Town

## EXECUTIVE SUMMARY

### 1. INTRODUCTION

In South Africa, many wastewater treatment plants (WWTPs) have rock filled trickling filters (TFs). Instead of using them for organics removal and nitrification, there is growing interest in integrating them with biological excess P removal activated sludge (BEPRAS) systems in an external nitrification flow scheme (Hu *et al.*, 2000). In such a scheme, the full influent flow (after primary settling) is discharged to the anaerobic reactor of the BEPRAS system, after which the activated sludge is separated from the water by internal settling tanks. The clarified supernatant is pumped to the trickling filter for nitrification and the activated sludge to the anoxic reactor of the BEPRAS system, where the nitrified wastewater rejoins the main BEPRAS system. This external nitrification BEPRAS system has several advantages over continuing to use the trickling filters for organics removal and nitrification, such as significantly reduced oxygen demand (~50%) and biological N and P removal on the full wastewater flow. To date full-scale studies have been performed only with rock media TFs in South Africa, for example that at Daspoort WWTP (Muller *et al.*, 2004, 2006a, b).

This is a summary of an investigation on full-scale operation of the NTF at the Citrusdal WWTP with a 1 ML/d capacity. The treatment works comprises a 4.2 days aerobic retention time in the first half of the facultative aerobic lagoon with solids settlement in the second half. The facultative aerobic lagoon was upgraded with a single plastic media NTF in order to meet standard effluent ammonia concentration requirements of < 3.0 mgN/L. The NTF has a specific media area of 142 m<sup>2</sup>/m<sup>3</sup>, total media area  $A_t = 23\ 100\text{m}^2$  and effective plastic media dimensions of 5.5 x 5.5 m and 5.4 m high. Wastewater is pumped from the unaerated zone of the oxidation pond and distributed over the TF media through a series of nozzles suspended above the media before the full flow is discharge to a series of maturation ponds.

The nitrification tower was tested over a period of two years to determine its nitrification capacity and to compare this with rock media NTFs. This report is an account of the performance of plastic media NTF at full-scale with the aim of where necessary retrofitting rock media TFs with plastic media. The principle objective of the full-scale investigation was to achieve apparent nitrification rates (ApNR) of > 1.0 gN/m<sup>2</sup>d which is equivalent to an ammonia mass removal of > 23.1 kgN/d (or concentration of 24.1 mgN/L) based on the ~ 1ML treatment capacity of the treatment plant at the Citrusdal WWTP. A parallel laboratory investigation into fixed media nitrification under controlled conditions has also been conducted for a period of 323 days. The objective of the laboratory-scale experiment was to also achieve ApNRs of greater than 1.0 gN/m<sup>2</sup>d.

## 2. LITERATURE REVIEW

There is extensive research on the design and operation of tertiary NTFs (Gujer and Boller, 1984 and 1986; Boller and Gujer, 1986; Parker *et al.*, 1989, 1995 and 1997). Plastic media TFs are efficient for nitrification application because of their high void ratio, efficient oxygen transfer and high specific surface area (optimum range of 150 – 200 m<sup>2</sup>/m<sup>3</sup>) in comparison to rock media TFs (Boller and Gujer, 1986 and Parker *et al.*, 1989, 1995). Nevertheless, nitrification rates achieved in rock media NTFs are comparable to plastic media on the basis of the mass of ammonia removed per total media surface area rather than per total media volume (Parker *et al.*, 1989 and Muller *et al.*, 2004, 2006a, b).

Nitrifiers are obligate aerobes which function optimally in a pH range of 7.0 – 8.5 and under the presence of low biodegradable soluble COD concentrations. Influent biodegradable soluble COD concentrations of < 30 mgCOD/L are reported by Parker *et al.* (1989) to be sufficiently low to limit competitive heterotrophic organism grown in the top media sections.

The following parameters are required to maximise the nitrifying performance of NTFs; continual forced air ventilation, low suspended influent solids and adequate media wetting. In order to ensure adequate media wetting, hydraulic loading rates (HLRs) can be increased by introducing an effluent recycle system or by operating two TFs in series with the lead tower being alternated periodically, every 7 -14 days (Gujer and Boller, 1984 and Parker *et al.*, 1995). HLRs of less than 3.0 m/hr on plastic media lead to dry patches which are conducive to the development of filter fly larvae that graze on the nitrifying biofilm (Boller and Gujer, 1986 and Parker *et al.*, 1989). Other predators which may be found in NTFs are worms and snails; with snails being more prevalent in rock media TFs. There are various researched methods of predator control in NTFs (Boller and Gujer, 1986; Lutz, 1990 and Parker *et al.*, 1997). TF flooding is recommended for biofilm and predator control.

The TF effluent ammonia concentration is required to be > 5.0 mgN/L for biofilm growth which is not ammonia-limited (Boller and Gujer, 1986 and Parker *et al.*, 1997). Full-scale operation of NTFs is subjected to varying influent diurnal ammonia loading conditions; thus under low influent ammonia loading conditions measures should be taken to increase the influent ammonia concentration by recycling the ammonia rich digester supernatant (depending on the treatment plant configuration) or introducing a dosing scheme.

The ammonia removal rate in this research is reported as the apparent nitrification rate (ApNR). It is calculated based on the ammonia mass removed (which is the difference in TF influent and effluent ammonia masses) per total media surface area. The apparent nitrification rates do not take into account the internal performance of the biofilm or the media inefficiencies such as poorly wetted areas, presence of predators and suspended solids.

### 3. METHOD OF INVESTIGATION

#### 3.1 FULL-SCALE

The site proximity and lack of on site testing facilities at the Citrusdal WWTP required for the samples to be kept for long periods before they were analysed. At each sample point collection, a filtered and unfiltered sample was collected; both samples were preserved with mercury chloride and kept frozen until they were analysed after a period of 3 to 4 weeks. Profile samples were collected on a monthly basis. They were filtered and preserved on site and analysed within a period of 72 hrs. The TF influent and effluent samples were analysed for free and saline ammonia (FSA), filtered and unfiltered COD, nitrates and nitrite and alkalinity; the profile samples have only been analysed for FSA. The COD concentrations reported in this paper are the total biodegradable and unbiodegradable COD concentration.

#### 3.2 LABORATORY-SCALE

The laboratory-scale experiment is not a scaled-down replica of the full-scale NTF at Citrusdal. It is filled with plastic spherical balls with a specific area of  $109 \text{ m}^2/\text{m}^3$  which makes it better comparable to rock media TFs in terms of oxygen transfer efficiency. The laboratory-scale NTF has a cross-sectional area of  $0.021 \text{ m}^2$ , a total media length of  $0.16 \text{ m}$  and a total media area of  $3.34 \text{ m}^2$ . It treats final effluent from the laboratory-scale UCT nitrification denitrification biological excess phosphate removal (NDBEPR) membrane system which has virtually zero suspended solids and low COD concentrations. The final effluent from the UCT system was dosed with an ammonium chloride solution to ensure non ammonia-limited operating conditions. At the start of the experimental period, the NTF was inoculated with nitrifiers for a period of two weeks in order to accelerate biofilm development on the plastic spherical balls media.

### 4. PRELIMINARY FULL-SCALE RESULTS

The preliminary full-scale results describe the performance of the NTF from the start of the investigation period of the Wastewater Research Group (WRC) at UCT from 2001 to August 2005. At the start of the investigation, the NTF relied on natural convection, was operated at HLR of  $1.3 \text{ m/hr}$  (no recirculation) and had no media depth sampling ports. The following alterations were implemented in order to enhance apparent ammonia nitrification rates (ApNRs) during the period from 2001 to August 2005:

- Four XPELAIR 320 W, 50 Hz forced-air blower fans were installed, one on each TF face, during July 2002.
- Four profile sampling ports were installed along the media depth of each of the four faces of the TF.
- The aerators in the facultative aerobic lagoon were repositioned and immersed to their maximum water depth in order to maximise their aeration potential and improve the organic removal capacity of the facultative lagoon.

- The hydraulic loading rate was increased from 1.3 to 2.0 m/hr by introducing a TF effluent recycle system during October 2005; this is equivalent to a recycle ratio of 1:1.5 with respect to the influent flowrate.

There is limited data on the performance and loading conditions of the NTF during the period 2001 to August 2005. The ammonia removal efficiency increased from 13% to 43% with the introduction of forced air ventilation fans during 2002 (Muller *et al.*, 2005). Despite this improvement, the effluent ammonia concentration was 28.7 mgN/L during 2004 which is significantly greater than the standard effluent requirement concentration of < 3.0 mgN/L. The TF effluent recirculation system was installed during 2005 in order to increase the HLR with the aim of improving the ApNRs. However, there was insufficient data to assess the apparent performance of the NTF after the TF effluent recycle installation.

## 5. APPARENT FULL-SCALE NITRIFYING PERFORMANCE

During the two-year investigation period from September 2005 to September 2007, the operation of the NTF at Citrusdal was subjected to numerous interruptions as a consequence of the lack in adequate maintenance of the system by the plant operator which resulted in a series of pump failures. Long waiting periods for the repair or replacement of equipment such as pumps and ventilation fans resulted in lengthy periods of non-optimum operating conditions.

**Table 1: Operating parameters of the full-scale nitrifying trickling filter during the investigation period**

Parameters	Units	Operating Periods			
		I-A	II-A	II-B	II-C
		Nov 05 - Feb 06 & Nov 06 - Feb07	Aug 06 - Oct 06	Apr - May 07	Jun - Sept 07
$Q_i$	m <sup>3</sup> /hr	40	40	40	40
HLR	m/hr	2.3	1.2	2.8	2.4
$N_{ai}$	mgN/L	30.5	34.7	35.5	29.5
$N_{ae}$	mgN/L	10.7	22.8	26.1	15.1
Sol. COD <sub>i</sub>	mgCOD/L	80	75	82	112
Sol. COD <sub>e</sub>	mgCOD/L	80	77	65	90
Part. COD <sub>i</sub>	mgCOD/L	149	123	153	369
Part. COD <sub>e</sub>	mgCOD/L	161	145	122	183
ALR	gN/m <sup>2</sup> d	1.21	1.37	1.51	1.24
ApNR	gN/m <sup>2</sup> d	0.92	0.58	0.40	0.61
Total OLR	gCOD/m <sup>2</sup> d	10.63	8.02	8.96	10.02
Total ORR	gCOD/m <sup>2</sup> d	1.62	1.88	2.20	2.73

Abbreviations: Total OLR- the sum of the particulate and soluble organic loading rates; Total ORR- the sum of the particulate and soluble organic removal rates.

Hence, the operation of the NTF during the investigation period has been categorized into periods of similar operating conditions, the operating parameters of which are listed in Table 1. Period I summarises the performance of the NTF during the summer (September to March) and Period II during the winter season (April to August).

The operating periods are characterised as follows; Period I-A: warm wastewater temperatures, HLRs = 2.3 m/hr and 4 to 3 fans in operation, Period II-A: cold wastewater temperatures and HLRs = 1.2 m/hr and 3 out of 4 fans in operation, Period II-B: cold wastewater temperatures, HLRs = 2.8 m/hr, 2 out of the 4 fans in operations and Period II-C: cold wastewater temperatures, HLRs = 2.4 m/hr and all 4 fans in operation.

Maximum ApNRs of  $\sim 1.00$  gN/m<sup>2</sup>d were achieved for a short period during February 2006 (see Figure 1) while the average during the summer period of average HLRs of 2.3 m/hr was 0.92 gN/m<sup>2</sup>d. The ApNRs increased marginally by 5% when comparing the performance during Period II-A and Period II-B where the hydraulic loading rates were 1.2 and 2.4 m/hr respectively. On the other hand, ApNRs improve by 35% when the NTF went from operating with 2 out the 4 fans during Period II-B to all fan fans in operation during Period II-C. These findings imply that during the winter period, increased HLRs have less of an impact on ApNRs compared to compromised oxygen supply to the NTF.

The average effluent ammonia concentration was 10.7 mgN/l during the summer period when maximum ApNRs were achieved - this is the lowest average concentration obtained compared to the winter periods (see Table 1). Although this average effluent ammonia concentration indicates favourable non ammonia-limiting operating conditions; this average is greater than the ammonia concentration requirement of 3.0 mgN/l. The average COD removed by the NTF appears to be negligible during the summer period with a significant value of approximately 20% removed during the winter period (Period II-C). This maybe due to the poor organic removal potential of wastewater treatment plant under cold climates as a consequence of lowered kinetic rates.

## 5.1 EFFECT OF HYDRAULIC LOADING CONDITIONS ON APPARENT NITRIFICATION RATES

Figure 1 illustrates the effect that the hydraulic loading conditions have on the apparent performance of the NTF. There was a 90% decline in ApNRs from February to March 2006 (see Figure 1) as a result of a reduction in the HLR from 2.0 to 0.5 m/hr due to a series of TF effluent recirculation and influent pump failures and power shortages that prevailed for the most part of the investigation during 2006. The ApNRs increased by 44 % (from 0.50 to 0.90 gN/m<sup>2</sup>d) when the HLRs were increased from 1.5 m/hr in 2006 to 2.3 in 2007. This increase in the HLR was due to a revised pump manifold configuration design in 2005 and by replacing the recirculation distribution nozzles with ones which were less sensitive to suspended solids. Under HLRs of < 1.5 m/hr (marked as solid line in Figure 1) there was an observed dominance of adult filter flies and worms in most of the NTF profile samples. However, at HLRs >1.5 m/hr the filter fly dominance was reduced (but not eradicated) and the presence of worms prevailed.

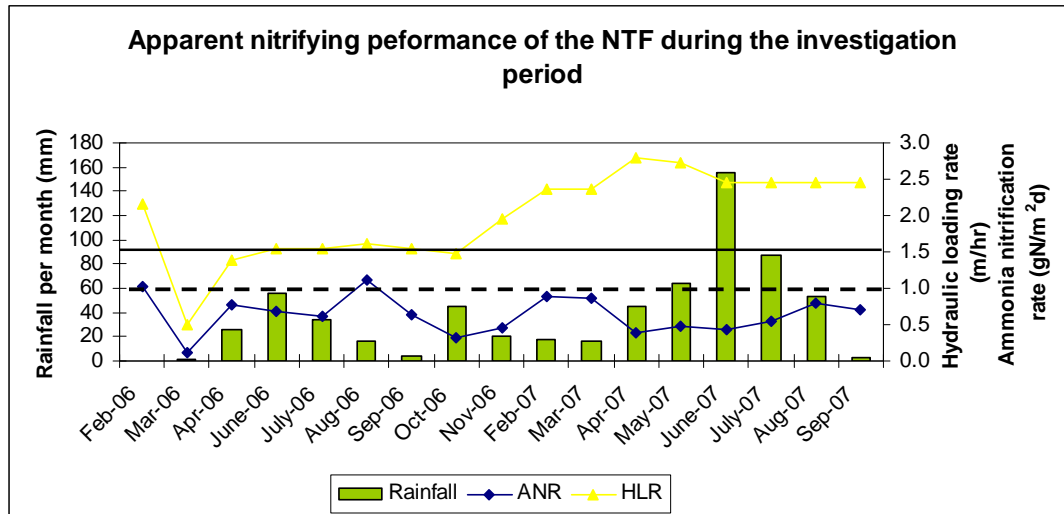

Figure 1: The effect of hydraulic loading conditions on the apparent nitrifying performance of the NTF during the investigation period

Citrusdal receives high rainfall during the winter period; with heavy rainfall during the June and July months. It is presumed that the media wetting is improved during the winter period due to the rain. The effect that the rainfall has on the apparent performance of the NTF is illustrated in the results obtained during 2006 under inadequate hydraulic loading application conditions of approximately 1.5 m/hr. There was an observed improved in the ApNRs during the rainy season (April to August) and a decline during the summer months of low rainfall and warmer temperatures which increases the evaporation rate of open water surfaces. The removal rates during the winter period of 2007 were significantly less than those of 2006 winter period despite the higher HLRs of 2.3 m/hr. The poor performance of the NTF during this period can be ascribed to inadequate ventilation. ApNRs of 0.40 gN/m<sup>2</sup>d were recorded for the period March to April 2007 when only 2 TF fans were in operation. However, when all the 4 fans were in operation, the ApNRs increased to 0.61 gN/m<sup>2</sup>d during the same winter period.

## 5.2 EFFECT OF ORGANIC LOADING ON APPARENT NITRIFICATION RATES

The NTF was subjected to higher total OLRs during the summer period due to prolific algal growth in the lagoon and TF effluent sump. However, higher organic removal trends were observed during the winter period compared to the summer. Soluble and particulate ORR trends exhibited random instances of high removal rates and virtually zero rates. It has been concluded that the random increases in the total ORRs exhibited by the NTF cannot solely explain poor performance of the NTF which was observed at times. The exclusive extent to which the observed total ORR effected the ApANRs could not be ascertained.

## 5.3 INTERNAL PERFORMANCE OF THE NITRIFYING TRICKLING FILTER

Profile samples were analysed for ammonia in order to determine the internal ammonia removal progression with depth in the TF. Figure 2 illustrates the ammonia concentration profile during the summer period of the investigation. The profiles of 15/09/05 and 20/10/05 were collected before the TF

effluent recycle installation when the HLR was approximately 1.3 m/hr. There was an observed dominance of adult filter flies and worms in most of the profile samples during this period. The approximately linear profiles of 16/02/06, 07/02/07 and 14/03/07 are indicative of homogenous and declining biofilm activity with depth which is associated with the optimum operation of single-stage operated NTFs (Boller and Gujer, 1984). Hence, the optimum apparent nitrifying performance obtained during Period I-A is substantiated by the corresponding approximately linear ammonia concentration profiles.

The effect of poor ventilation under warm and cold wastewater temperature is noted in the significant difference in the profiles of 14/03/07 and 11/04/07. During both months the NTF was operating with 2 out of 4 fans and HLRs were 2.3 and 2.7 m/hr respectively but the maximum and minimum ambient temperatures fell from 33.5°C and 15.8°C in March to 29.8°C and 13.1°C in April respectively. It is hypothesised that under colder climates the transfer of oxygen may be a limiting factor to biofilm growth, which should be verified with profile DO concentrations and wastewater temperature data.

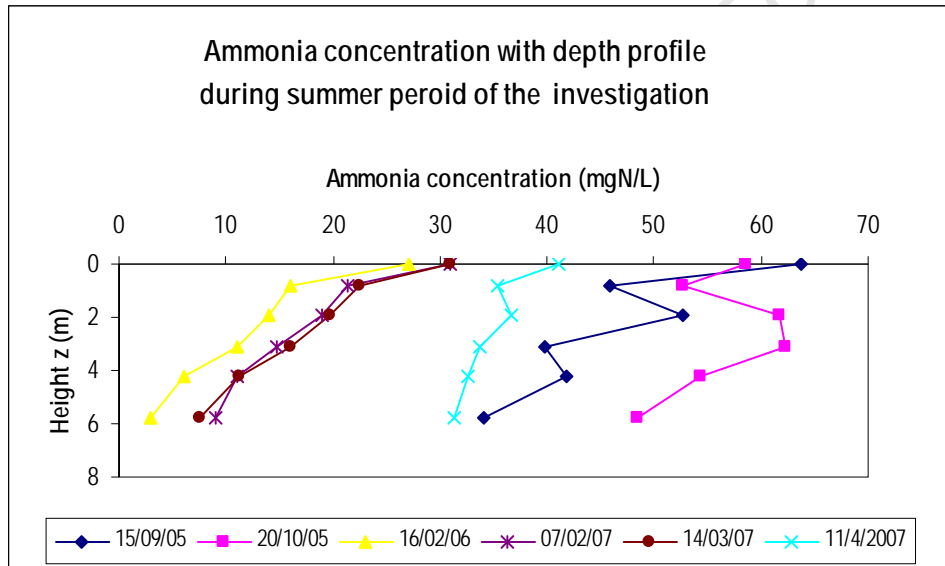
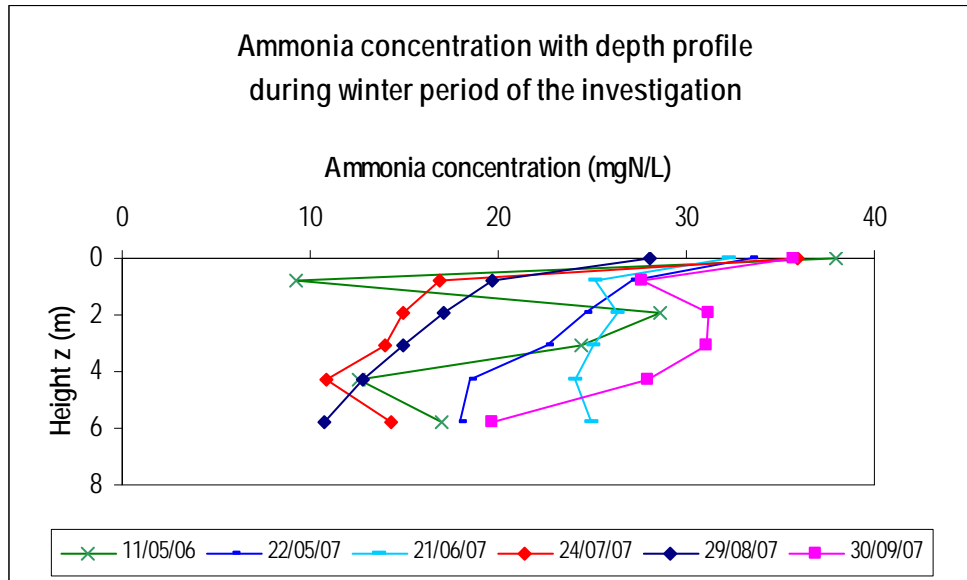

Figure 2: Ammonia concentration profile during the summer period of the investigation

The internal performance of the NTF during the winter period of the investigation is illustrated in Figure 3. The profiles are not indicative of homogenous and declining biofilm activity as was illustrated under optimum operating conditions in some of the profiles in Figure 2.



**Figure 3: Ammonia concentration profile during the summer period of the investigation**

There was an observed increase in ammonia concentration with depth in the middle region of the TF media (see Figure 3). The middle section is from 0.80m to 3.10 m of the TF media. Analysis of the winter profile samples for microbial activity showed a significant presence of filter fly remains (debris) and worms (*Nematodae*). *Nematodae* are primitive segmented worms which are found in partially treated raw municipal wastewaters and their presence in this plastic media NTF was regarded as a negative sign for nitrifying biomass activity. Sunlight penetrating through the cracks of the two-phase brick wall which houses the plastic media stimulated motile algal growth in the TF; significant traces of which were found in the middle section of all the profile samples.

The findings from the microbial analysis suggested that during the winter period under the hydraulic loading conditions at this site, there is inconclusive evidence of homogenous biofilm activity. The increase in ammonia concentrations in the middle media sections may be as a consequence of the ammonia that is released to the wastewater during the break down of the chitinous exoskeleton of the filter fly and other particulates; however, it is doubtful that the ammonia released to the NTF is as significant as displayed in some of the profiles in Figure 3.

Internal ApNRs are calculated based on the profile ammonia concentrations with depth and by only taking into account the approximately linear profile relationships. Figure 4 illustrates the internal ApNRs of the NTF as a function of depth.

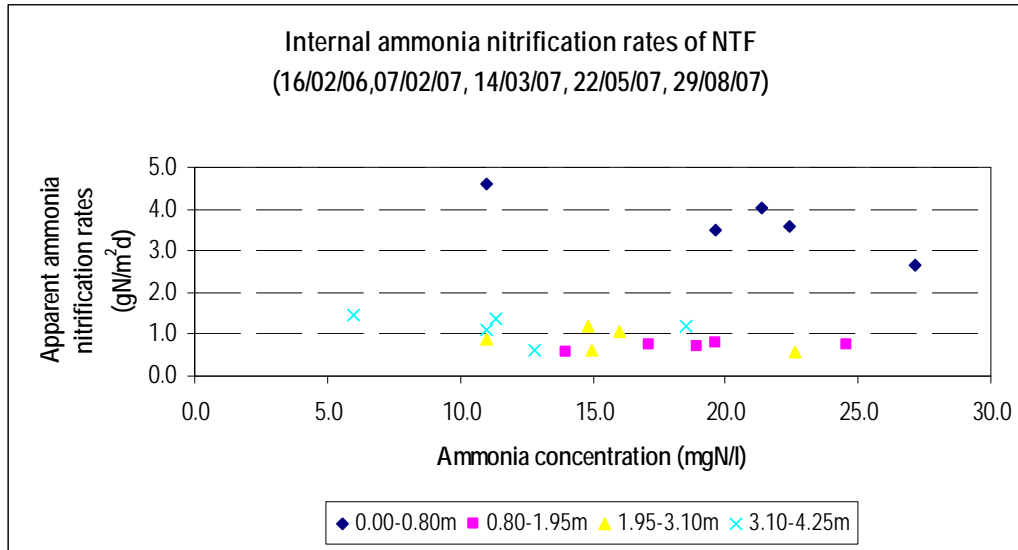

Figure 4: Internal apparent nitrification rates

The high apparent removal rates displayed in the top section (0.00 – 0.80 m, see Figure 4) of the NTF implies that under the optimum operating conditions of Period I-A this section of the TF media is dominated by nitrifiers. This corroborates the assumption that the apparent biodegradable soluble COD removed by the NTF is sufficiently low to allow for the development of nitrifiers at the top of the TF media. The middle section (0.80 – 3.10 m) exhibited poor apparent removal rates that were similar to the removal rates observed from the bottom media section. This implies patchy biofilm presence, which is characteristic of the lower TF section. Stone *et al.* (1975) found the presence of algae in a NTF treating unclarified lagoon effluent to have a negative effect on nitrifying biofilm development. Hence, it has been inferred that the evidence of motile algal growth observed under microbial analysis was the chief reason for the poor performance in the middle TF media region.

#### 5.4 NITROGEN BALANCE

A poor nitrogen balance was achieved from the full-scale results. There were significant discrepancies in the results obtained from the FSA and  $\text{NO}_3 + \text{NO}_2$  and alkalinity tests. The long waiting periods (3 to 4 weeks) before the samples were analysed for the respective tests could have had an effect on the accuracy of the tests results even though the samples were preserved, filtered and frozen until they were analysed for the respective tests. However, the internal performance and microbial analysis of the NTF substantiate the apparent optimum performance of the NTF of  $\sim 1.00 \text{ gN/m}^2\text{d}$ .

### 6. APPARENT LABORATORY-SCALE NITRIFYING PERFORMANCE

The laboratory-scale experiment was carried out under constant laboratory temperature of  $20^\circ\text{C}$ , the influent COD concentration was determined by the COD removal capacity of laboratory scale UCT NDBEPR membrane system and the ALRs and HLRs were regulated in order to achieve optimum nitrifying conditions. During the start-up period, the HLR and ALR effects were coupled. The initial

design of the NTF allowed for one pumping source of the TF influent and effluent recirculation flows and thus an increase in the pump out put resulted in an equal increase in the ALR and the HLR; the apparent nitrifying performance of the TF achieved during the start up period of 120 days was 0.23 gN/m<sup>2</sup>d. The ammonia and hydraulic loading conditions were hence decoupled to allow for more flexibility in independently varying the influent loading conditions with the aim in improving ApNRs. This was done by introducing independent pumping sources for the TF influent and effluent recycle flows. Table 2 lists the operating parameters of the laboratory-scale NTF under the varying HLR conditions after the ALR and HLR effects were decoupled.

**Table 2: Operating parameters of the laboratory-scale nitrifying trickling filter during the experimental period**

	Q <sub>i</sub>	Q <sub>R</sub>	HLR	N <sub>ai</sub>	N <sub>ae</sub>	ApANR <sup>1</sup>	ALR	SCOD <sub>i</sub>	SOLR	SORR
Period	L/d	L/d	m/d	mgN /L	mgN /L	gN /m <sup>2</sup> d	gN /m <sup>2</sup> d	mgCOD /L	gCOD /m <sup>2</sup> d	gCOD /m <sup>2</sup> d
1	101	158	12.4	46.2	25.5	0.59	1.40	127	3.30	0.93
2	101	230	15.8	32.1	10.6	0.65	0.97	83	2.57	0.81
3	144	230	17.8	40.5	18.4	0.95	1.74	73	3.11	1.01
4	202	230	20.6	39.4	10.8	1.72	2.37	79	4.27	1.25

Abbreviations: SCOD<sub>i</sub> = influent soluble COD; SOLR = soluble organic loading rate; SORR = soluble organic removal rate; Q<sub>i</sub> = influent flowrate; Q<sub>R</sub> = trickling filter effluent recycle flowrate

<sup>1</sup> Apparent ammonia nitrification rates

The maximum ApNRs achieved during the experimental period was 1.72 gN/m<sup>2</sup>d which is equivalent to an ammonia mass removal of 5.76 gN/d or 73% removal of the influent mass. The NTF removed approximately 30% of the soluble influent OLR throughout the experimental period. This is equivalent to an apparent biodegradable soluble COD concentration removed of 20-30 mgCOD/L which is less than the threshold concentration of 30 mgCOD/L reported by Parker *et al.* (1989). Hence it has been inferred from the results in Table 2 that the observed soluble organics removed are not the principal reason for the poor performance of the NTF during Periods 1-3.

Figure 5 illustrates the effect of hydraulic loading conditions on the ApNRs. Adult filter flies and worms were observed on the TF media when the operating HLRs were < 15.8 m/d. Under operating HLRs > 15.8 m/d, the adult filter fly prevalence ceased but the worms were not eradicated even under HLRs of 20.6 m/d when the maximum ApNRs were achieved. ApNRs increased from 0.96 to the maximum of 1.72 gN/m<sup>2</sup>d when the HLR was increased from 15.8 to 20.6 m/d. This is equivalent to a 44% increase in ApNRs which indicates the sensitivity of the NTF to hydraulic loading conditions.

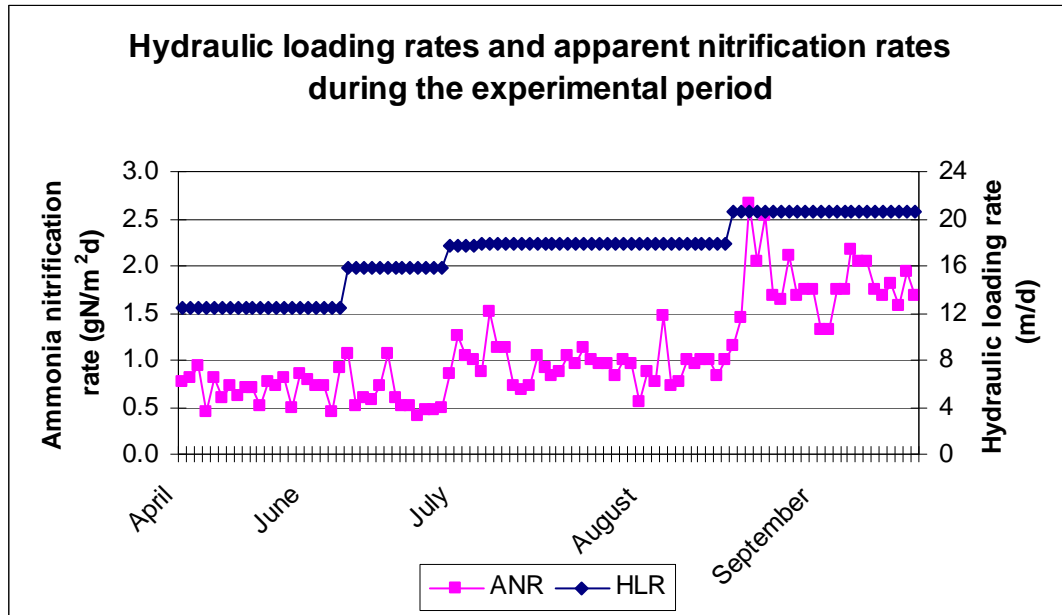

Figure 5: Effect of the hydraulic loading rate on the apparent performance of the laboratory-scale nitrifying trickling

## 6.1 NITROGEN BALANCE

A nitrogen balance of 106 and 114% with respect to the alkalinity consumption measurements and  $\text{NO}_3 + \text{NO}_2$  production verifies the maximum apparent removal rates of  $1.72 \text{ gN/m}^2\text{d}$  achieved during the experimental period. There was evidence of denitrification nitrification throughout the experimental period. This is ascribed to the inefficient oxygen transfer capacity of the plastic spherical balls media used, which results in dead pockets of air with no oxygen.

## 7. COMPARISON OF THE RESEARCH RESULTS WITH LITERATURE RESULTS

The performance of the full-scale NTF at Citrusdal is compared to results achieved at a full-scale rock media NTF in South Africa (Muller *et al.*, 2004 and 2006a, b) and other pilot-scale plastic media NTFs performance reported in literature (see Table 3). It is evident that rock media removal rates compare well with those achieved using plastic media. The optimum ApNRs of  $1.00 \text{ gN/m}^2\text{d}$  achieved at Citrusdal was under oxygen-limited conditions and at the maximum hydraulic loading capacity of the system. Although this was the maximum performance of the system given the site operating conditions, the ApNRs are the lowest in comparison to the removal rates listed in Table 3. The average nitrification removal rates reported by Parker *et al.* (1989) were calculated using a model that only takes into account oxygen-limited operating conditions which is different to the calculation of apparent nitrification removal rates used in this research. However, it has been included to demonstrate the potential of achieving higher removal rates with single-stage operated NTFs under higher HLRs. Operating TFs in

series allows for effluent ammonia concentrations < 5.0 mgN/L in a sustainable manner without resulting in ammonia-limited conditions and patchy biofilm growth as would be the case with single-stage operated NTFs.

Table 3: Comparison of the optimal nitrifying performance of NTFs

Parameter	Units	SOURCE				
		Parker <i>et al.</i> , 1989	Parker <i>et al.</i> , 1995	Muller <i>et al.</i> , 2006	Mofokeng <i>et al.</i> , 2008	Mofokeng <i>et al.</i> , 2008
Research type		Pilot-scale	Pilot-scale	Full-scale	Full-scale	Laboratory-scale
No. of NTFs		1	2	2	1	1
Q <sub>i</sub>	ML/d	237 x10 <sup>6</sup>	np	10.6 x10 <sup>6</sup>	0.96 x10 <sup>6</sup>	202 x10 <sup>6</sup>
Media depth	m	6.7	3.6	3.6	5.4	1.48
Media type		Plastic Cross flow	Plastic Cross flow	Rock	Plastic Cross flow	Spherical plastic balls
Media density	m <sup>2</sup> / m <sup>3</sup>	138	140	45	142	109
Temperature	°C	15	15	22.4	np	20
HLR	m/h	5	5 <sup>d</sup>	2.6 <sup>d</sup>	2.3	0.86
ALR	gN/m <sup>2</sup> d	np	2.4	1.42	1.4	2.37
ANR	gN/m <sup>2</sup> d	2.3 <sup>b</sup>	2.1 <sup>a</sup>	1.25 <sup>a</sup>	1.00 <sup>a</sup>	1.72 <sup>a</sup>
Nrem	mgN/L	16	24.8	14.8	24.1	28.5
Nae	mgN/L	14	1.85	2.37	8.0	10.9

<sup>a</sup> Apparent nitrification rates

<sup>b</sup> Average nitrification rates (calculated using a model)

<sup>d</sup> Sum of the equal HLRs on each NTF

The hydraulic load applied during the investigation carried out by Parker et al. (1989) on a single stage operated NTF is approximately two times the HLR applied at CWWTP (2.3 m/hr). The nitrification rate obtained by Parker et al. (1989) is also approximately twice the maximum ApANR achieved at Citrusdal. The maximum pump output obtained during the investigation was 2.8 m/hr and the structure of the TF started leaking once the recirculation system was in operation. It was hence not possible to reach a HLR of 5 m/hr at Citrusdal due to structural integrity limitations and the capacity of the pumps used. Therefore, it was also not possible to determine how much more the ApANRs could have improved by if the HLR recorded in Table 3 was doubled.

## 8. CONCLUSIONS AND RECOMMENDATIONS

The following conclusions have been drawn from the findings of the apparent nitrifying performance of the single-stage NTF at the Citrusdal WWTP:

- Apparent nitrification rates are sensitive to hydraulic loading conditions.
- There is limited biomass activity during the rainy winter seasons, which is corroborated by the irregular internal ammonia profile.
- Inadequate ventilation during the cold weather is detrimental to ApANRs
- The poor ammonia removal profile of the middle media section of the TF is due to algal growth on the media and influent particulates that clog the media.

The following recommendations are made with regards to the application of plastic media NTFs at South African WWTPs:

- The nitrifying tower should be a waterproof structure. The two-phase brick wall structure was found to be inadequate in this regard.
- Operating NTF in series with the lead tower alternated periodically will provide for effluent ammonia concentrations of < 3.0 mgN/L (standard effluent requirements) without resulting in ammonia-limited operating conditions that lead to patchy biomass growth.
- Nozzle distribution systems, which are insensitive to particulates, are required if unclarified secondary wastewater is treated.
- Dedicated operators are required to maintain optimum operating conditions, such as the maintenance of operating equipment, the cleaning of the nozzle distribution system if unclarified secondary wastewater is treated and the over seeing of dosing schemes in single-stage operated NTF were they are required.
- Internal clarifiers are necessary in order to reduce the influent particulate loading on the TF, which has a negative impact on the performance of the NTF, and to reduce the frequency of cleaning distribution nozzles.

# CHAPTER 1

## EXTERNAL NITRIFICATION IN A TERTIARY NITRIFYING TRICKLING FILTER – FULL-SCALE INVESTIGATION

### 1.1 OBJECTIVE OF THE RESEARCH INVESTIGATION

In South Africa, many of the old wastewater treatment plants that used trickling filters (TFs) for organic COD removal have been upgraded by extending them with the biological nutrient removal activated sludge (BNRAS) systems (Hu *et al.*, 2000). These, usually rock media, TFs have been retained as an added unit to reduce the organic load on the BNRAS system. The problem with this approach is that only the wastewater treated in the BNRAS has had its nutrients removed. The external nitrification (EN) design concept is essentially the use of TFs for nitrification within the BNRAS system in order to achieve biological nutrient removal on the full wastewater flow. The University of Cape Town (UCT) Wastewater Research Group (WRG) has done extensive research on the full-scale nitrification performance of such a rock media TF operating in a BNRAS system at the Daspoort wastewater treatment plant in Pretoria.

The objective of this research is to investigate the full-scale EN performance of a plastic media nitrifying TF (NTF). The Citrusdal wastewater treatment plant (CWWTP) in the Western Cape presents such an opportunity. It is an aerated facultative lagoon treatment plant. The lagoon effluent (consequently influent to the NTF) is regarded to be similar to that of the anaerobic reactor supernatant, being very low in suspended solids and high in ammonia, which is discharged on the NTF in the external nitrification (EN) BNRAS system.

### 1.2 BACKGROUND TO THE STUDY

A schematic layout of the operation of the old TFs in SA that have been incorporated in the upgrade of the treatment plant to BNRAS systems is shown in Figure 1.1. Some of the overflow from the primary settling tank is treated for organic COD removal in the TF while the rest is discharged in the activated sludge system for COD, Nitrogen (N) and Phosphorus (P) removal. The TF effluent still requires further treatment for N and P removal before it is discharged to the river. The treatment and disposal options of the TF effluent which are usually adopted are illustrated in Figure 1.1

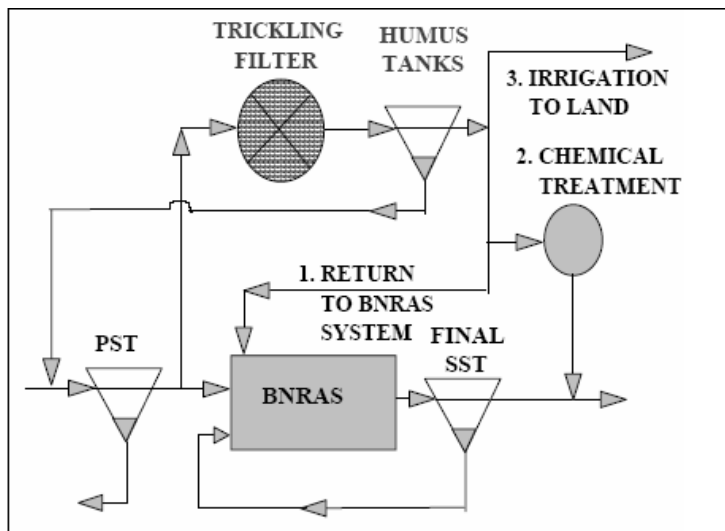

Figure 1.1: Conventional integration of TFs with BNRAS systems

SOURCE: Hu *et al.*, 2000

- 1) One option is returning some of the effluent from the TF to the BNRAS system for further nutrient removal. This has a negative impact on the treatment efficiency of the BNRAS system. 'The introduction of the effluent to the BNRAS system increases the TKN/COD and P/COD ratios and consequently increases effluent N and P concentrations' (Hu *et al.*, 2000). Consequently, the effluent P and N concentrations may exceed required standards.
- 2) The effluent could be chemically treated to precipitate P before final discharge. This reduces the alkalinity of the wastewater and only reduces the effective P/COD of the wastewater on the BNRAS system (Hu *et al.*, 2000). However, the option of chemical treatment is a costly one.
- 3) Hu *et al.* (2000) are of the opinion that the option of disposing the TF effluent by irrigation on land at wastewater treatment plants will soon be carefully scrutinised in South Africa because it leads to a significant loss of valuable surface water.

The introduction of external nitrification within the BNRAS system aims to improve the nitrification capacity of activated sludge system designs by assisting where the system is weak (nitrification) and not robbing of its strength (nutrient removal with organics).

In the proposed external nitrification design concept of Hu *et al.* (2000), as illustrated in Figure 2.1, all the influent settled wastewater discharged to the anaerobic reactor of the BNRAS system. The outflow from the anaerobic reactor is settled in the internal settling tank to remove activated sludge and suspended solids before it is nitrified in the TF. The NTF effluent is discharged in the anoxic reactor together with the internal settling tank sludge underflow for denitrification.

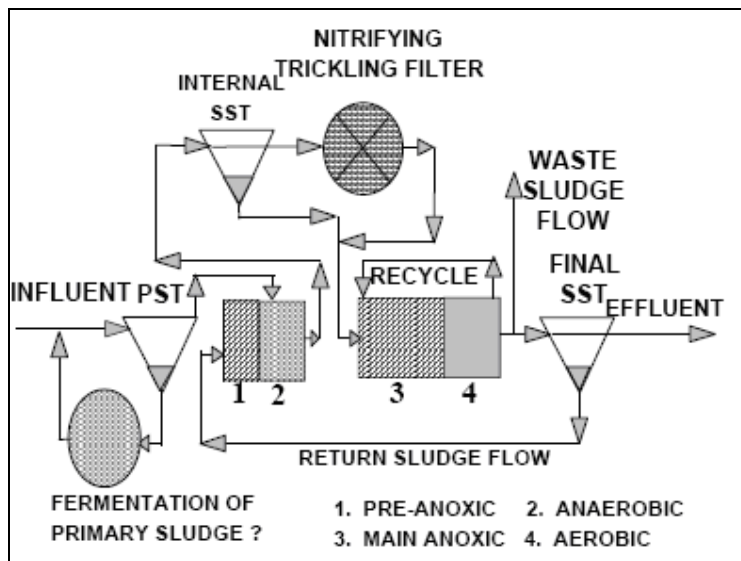

Figure 1.2: Proposed integration of trickling filters with BNRAS to achieve ENBRAS

Source: Hu *et al.*, 2000

The benefits of this design concept are as follows:

- i) The treatment capacity of the system is increased without increasing the aeration capacity or the volume of the aerobic reactor.
- ii) The oxygen demand in the aerobic zone is reduced considerably because the oxygen required for nitrification is now obtained 'free' through natural air convection in the NTF.
- iii) Sludge age can be reduced to 8 -10 days because nitrification is no longer required allowing a higher organic load on the BNRAS system.
- iv) In the laboratory experiments, the sludge settleability was significantly better ( $DSVI \approx 100\text{mL/g}$ ) than the conventional internal nitrification BNRAS system ( $DSVI > 150\text{mL/g}$ )

The disadvantages of the EN BNRAS system are as follows:

- i) an internal settling tank is required and
- ii) biological P removal is sometimes decreased due to the anoxic P uptake BEPR taking place in the systems triggered by nitrate load exceeding the denitrification potential of the main anoxic reactor and the small aerobic reactor.

In order to attain the cost saving benefits of EN in TFs, the characteristics that define the optimum operating conditions of NTFs must be taken into account. This research investigates these optimum operating conditions for EN in a plastic media NTF and compares these with rock media. Research has shown that the following operating variables have a significant effect on nitrification rates in NTFs; hydraulic loading rates (HLRs), ammonia loading rates (ALRs), influent total suspended solids (TSS) concentration and wastewater temperature. The nitrifying biofilm requires oxygen, is pH sensitive and grow best at virtually zero organic (COD) loading rates.

### 1.3 LIMITATIONS TO THE RESEARCH

The period of investigation of the full-scale performance of the NTF at the CWWTP was from February 2006 to October 2007. The full-scale investigation at the treatment plant presented many challenges. The main one being its remoteness and establishing the necessary equipment to enable the required measurements to be made. The treatment plant is approximately 200km outside Cape Town thus it was not always feasible to conduct frequent site visits. The treatment plant had limited resources in terms of skilled personnel and analysis equipment. There are no laboratory facilities where sample analysis can be performed on site. Consequently, the samples had to be preserved in order to keep them for longer periods so that they could be analysed in Cape Town. Also there was a lack of financial resources and person power at the Citrusdal municipality, so it was difficult to maintain optimal operation of the nitrification tower.

Lack of time and sanitary engineering knowledge made it difficult at times to communicate what was required from the designated personnel in charge of the maintenance and operation of the NTF. Long waiting periods for repairs to operation equipment such as fans, pumps and aerators in the lagoon also made it difficult to maintain desired operation conditions on the NTF for adequately long periods. To not constrain the research project to the vicissitudes of rural local authorities, a laboratory-scale fixed media nitrification column was also operated to collect additional information.

### 1.4 PROBLEMS TO BE INVESTIGATED

The problems that were investigated are the effect that the main operating parameters have of maximum nitrification rates, namely; hydraulic loading rate (HLR), ammonia loading rate (ALR) and organic loading. The internal behaviour of the NTF at the CWWTP was investigated by taking samples along the plastic media height of the tower.

The objective of this laboratory experiment was to investigate maximum attainable apparent nitrification rates under a controlled environment. However, the laboratory scale NTF is not a scaled down model of the full-scale NTF and can therefore not be used for direct comparison or verification of the full-scale results. This laboratory-scale investigation is an amplification of the main objective of the research, which is the investigation of full-scale performance of EN in plastic NTFs.

## 1.5 SCOPE OF THE RESEARCH

This investigation quantifies the *apparent* ammonia nitrification rates (ApANR) of a single stage operated full-scale plastic media nitrifying tower, which is 5 long x 5 wide x 6 m high. This is calculated by expressing nitrification rates as the mass of ammonia removed per day in the NTF per total media specific surface area (gN/m<sup>2</sup>d). The calculation of apparent nitrification rates does not take into account the internal kinetics of the biofilm (poor wetting, short-circuiting, etc) and hence is essentially the difference between influent and effluent ammonia concentrations to the NTF. This research does not apply any of the theoretical models to determine the *actual ammonia nitrification rate* (AcANR) with depth at full-scale or laboratory scale. The calculation of actual AcANR is only valid for oxygen-limited conditions i.e. when the NTF effluent ammonia concentration is > 5.0 mgN/l.

University of Cape Town

## CHAPTER 1: INTRODUCTION: EXTERNAL NITRIFICATION IN A TERTIARY NITRIFYING TRICKLING FILTER – FULL-SCALE INVESTIGATION

1.1	OBJECTIVE OF THE RESEARCH INVESTIGATION	1
1.2	BACKGROUND TO THE STUDY	1
1.3	LIMITATIONS TO THE RESEARCH	4
1.4	PROBLEMS TO BE INVESTIGATED	4
1.5	SCOPE OF THE RESEARCH	5

University of Cape Town

Figure 1.1: Conventional integration of TFs with BNRAS systems	1-2
Figure 1.2: Proposed integration of trickling filters with BNRAS to achieve ENBRAS	1-3

University of Cape Town

## CHAPTER 2

# LITERATURE REVIEW: TERTIARY NITRIFYING TRICKLING FILTER PERFORMANCE

### 2.1 INTRODUCTION

This is a literature review on the operating requirements and performance of tertiary NTFs. This chapter summarises the investigations that elucidate on the operation of the internal biofilm with the aim of understanding the effect that required operating conditions have on maximum nitrification rates. The objective of the review is to comparatively determine the applicability of the literature findings to the investigation at the CWWTP.

The discussions in this chapter start with a brief summary of the definition of the biological nitrification process and its requirements followed by an overview of the early developments of external nitrification. A detailed discussion on the biofilm is presented in an endeavour to understand the internal operation of the fixed biofilm. Operating parameters and optimum operating conditions required for efficient NTF performance are then discussed at length. This chapter is concluded with a summary of the findings from the literature.

### 2.2 NITRIFICATION PROCESS DEFINITION AND REQUIREMENTS

Nitrification is the oxidation of ammonia to nitrate. The reaction occurs in two steps:

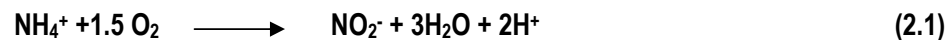

Step 1 is the oxidation of ammonia to nitrite. The bacteria responsible for this process are obligate aerobes called autotrophic ammonia oxidising bacteria e.g. AAOs (*Nitrosomonas*). Autotrophic nitrate oxidising bacteria e.g. ANOs (*Nitrobacter*) are responsible for the oxidation of nitrite to nitrate that takes place during the second step. The rate that AAOs convert ammonia into nitrite is much slower than the rate that nitrite is converted to nitrate by ANOs (Downing *et al.*, 1964). Hence in municipal wastewaters

where ammonia is the major N constituent, the nitrification process is controlled by equation (2.1) which is the limiting step.

The nitrifiers have a maximum specific growth rate of 0.33/d at 20°C at a pH of 7.2 (Ekama and Marias, 2007 unpublished). Therefore, the most limiting factor for this process in wastewater treatment, utilizing the activated sludge technology, is sludge age. The growth rate of the nitrifying organisms is influenced by temperature, hydrogen concentration of the mixed liquor (pH) and high oxygen concentrations. For optimal nitrification rates, the pH should be in the range between 7.0 and 8.5 with sharp rate declines outside of this range (Ekama and Marias, 2007 unpublished).

The oxidation of ammonia to nitrate generates acidity ( $H^+$ , equation 2.1) i.e. lowers the pH. According to WRC (1984), the oxidation of 1mgN/l as ammonia is equivalent to the destruction of 7.1mg/l of alkalinity (expressed as  $CaCO_3$ ). Thus there has to be sufficient influent alkalinity in order to avoid alkalinity limited conditions and low pH during the biological nitrification process.

Virtually zero soluble biodegradable COD concentrations are required for the growth of nitrifying biofilm. Heterotrophic organisms also require oxygen for the degradation of organic COD. Therefore, both heterotrophic and nitrifying organisms compete for oxygen. Heterotrophic organisms have a much faster growth rate (~10x) compared to the slow growing nitrifying organisms. As a consequence, at high organic COD concentrations nitrifying biomass growth is out competed by the faster growing heterotrophic organisms. This happens in biofilters treating settled municipal wastewater – nitrification commences only once the organic concentration is low in the lower section of the TF. Tertiary (after near complete organic removal) nitrification filters (NTFs) are distinctly different to this – organic concentrations in the influent are very low, so that nitrification can take place throughout the TF.

### 2.3 DEVELOPMENTS OF THE EXTERNAL NITRIFICATION (EN) CONCEPT

In the early developments of wastewater treatment processes, trickling filters (TFs) were primarily used for the removal of soluble organic biodegradable organisms. Although these trickling filters were chiefly intended for organic COD removal, it was found that in some cases nitrification did take place. Consequently, there have been numerous investigations on the optimum use of TFs for nitrification.

The first reference to a design proposal for EN in an activated sludge system was made by Balakrishnan and Eckenfelder (1967, 1970). They introduced the contact- stabilization-denitrification process with the aim of enhancing denitrification rates. The process introduced an internal secondary settling tank (clarifier) after the removal of organic matter in what they called the contact tank. The overflow from the clarifier, which had a high ammonia concentration and low soluble biodegradable COD concentration, was discharged to the TF for nitrification. The underflow from the clarifier, high in active biomass, and effluent TF rich in nitrate then undergoes denitrification.

Since then there have been many investigations on optimum operating conditions required for maximum nitrification rates in tertiary NTFs. However, there seems to be little published data on the performance of full-scale EN in NTFs. The majority of the literature found was on pilot-scale performance of external nitrification in NTFs (Boller and Gujer, 1984, 1986a, 1986b; Parker *et al.*, 1986 and 1989, Gullick and Cleasby, 1990, Lutz *et al.*, 1990 and Parker *et al.*, 1997). Recently there have been a number of feasibility investigations on the potential of full-scale external nitrification in biological nutrient removal activated sludge (ENBNRAS) system implementation to South African wastewater treatment plants (Hu *et al.*, 2000). From laboratory studies, the applicability of EN in BNRAS systems has been found to be favourable to South African wastewater treatment plants (Hu *et al.*, 2000 and 2003) and the advantages and disadvantages of such a system have been discussed in Chapter 1. The first investigation on full-scale EN in BNRAS system operation has been done by Muller *et al.* (2004, 2005, 2006a and 2006b).

## 2.4 EXTERNAL NITRIFICATION IN FIXED MEDIA TRICKLING FILTERS

A feasibility study by Stone *et al.* (1975) investigated the options of extending the aerated lagoon treatment plant at Sunnyvale, California, USA to include either; external nitrification on fixed growth reactors (TFs), ammonia absorption on clinoptilolite or break-point chlorination in order to improve treatment effluent quality. They found external nitrification using a TF to be the most economical alternative.

Stone *et al.* (1975) investigated (at pilot-scale) the alternatives of either externally nitrifying clarified or unclarified secondary effluent. They found that nitrifying unclarified effluent would require 30% more media surface area and would produce higher effluent ammonia concentrations than nitrifying clarified effluent for the same temperature range of 13° to 19°C. They ascribed the lower ammonia oxidation results of treating unclarified effluent to a 20 to 40% reduction in TSS and organic COD concentrations across the TF. The removal of organic COD by the NTF indicates heterotrophic growth and as mentioned before, heterotrophic growth inhibits nitrifying biomass growth due to its faster growth rate. Therefore, biomass growth competition between the two organism groups may partly explain the higher effluent ammonia concentrations. Stone *et al.* (1975) found, from their observations, that a large portion of the TSS that was removed was algae. They suspected that as long as the algae remained viable it could be suppressing nitrifier growth in its vicinity and hence furthermore decreasing the area available for nitrifying bacteria growth in the TF.

Despite the lower ammonia oxidation performance of the NTF, the treatment of unclarified lagoon effluent was found to be the most economical by Stone *et al.* (1975). To achieve the required effluent ammonia concentrations, Stone *et al.* (1975) suggested that the effluent NTF could be treated for further ammonia removal by using the break-point chlorination process if necessary. This process uses chlorine to oxidise ammonia. The authors recommended that this method could be used to provide back-up for instances when nitrification rates were low. The advantage of using the break-point

chlorination process is that it could be performed simultaneously with the disinfection of the effluent. However, chlorination of final effluent can reduce the reuse value of the water due to formation of chlorinated organics such as trichalomethanes.

## 2.5 FIXED BIOFILM MODEL

In an endeavour to understand the internal operation of the NTF, the fixed biofilm model is discussed in the sections that follow. Fixed biofilm models are developed by performing mass balances on substances migrating across the biofilm at steady state. Williamson and McCarty (1976), developed a theoretical biofilm model which is based on the following parameters; Monod maximum utilization rate and the half-velocity coefficients, the biofilm and stagnant liquid layer depths, the substrate diffusion coefficients through the biofilm and water, the biofilm density and the bulk liquid substrate concentration. This model highlights the fundamental processes that take place in biofilms grown on fixed media.

Figure 2.1 illustrates the substrate profile within the biofilm by Williamson and McCarty (1976). The definitions of the symbols used in Figure 2.1 are as follows;  $S_0$  - concentration of the substrate in the bulk liquid,  $S_s$  - concentration of substrate at the biofilm surface,  $S_c$  - concentration of the substrate within the biofilm cellular matrix and deep within the biofilm a constant limiting value is denoted by  $S_i$ . If the biofilm is not metabolism limited, then the substrate concentration within the depths of the biofilm will reach a minimum value of  $S_i$  (Williamson and McCarty, 1976). According to them, this situation will occur only in relatively deep biofilms. In such deep biofilms, a condition may occur when the biofilm surface flux does not increase with an increase with biofilm beyond a critical biofilm depth where  $S_c = S_i$ . In thin biofilms, the depth is limited by hydraulic shearing or sloughing of the organism mass. This means that substrate utilization may occur throughout the entire layer. Consequently resulting in metabolism-limited conditions where there is insufficient biofilm depth for the removal of the substrate in question.

The substrate removal capacity of a fixed biofilm is dependent on the depth of the biofilm. In deep biofilms the effective depth,  $L_e$  is less than  $L_c$  while for thin biofilms  $L_e$  is greater than  $L_c$  (Figure 2.1). The biofilm model present by Williamson and McCarty (1976) is intended for prediction of utilization rates of deep biofilm. Concomitantly the authors found that deep biofilms will develop under conditions in which the sloughing of organisms primarily results from zero substrate conditions within the biofilm. They also found deep fixed biofilms to be more stable to shock loads and adverse environmental conditions compared to suspended bacteria reactors.



of the reason for limited substrate uptake by a fixed biofilm. The transfer of oxygen to the biofilm and the pH of the bulk liquid were found to affect substrate uptake by the nitrifying biofilm (Siegrist and Gujer, 1987).

Mass transfer is influenced by the process of molecular diffusion from the laminar flow of wastewater over the biofilm. Molecular diffusion is a function of cell size, biofilm porosity and the ability and efficiency of the cells to sequester the substrate (Logan *et al.*, 1987a). Most biofilm models use a fixed diffusion coefficient over the entire biofilm depth (Siegrist and Gujer, 1985). The fixed diffusion coefficient assumption is made to simplify modelling the internal biofilm behaviour of NTFs. Most investigators have generally assumed a value equal to the corresponding value in water in order to estimate the diffusion coefficients of their models (Williamson and McCarty, 1976). There have been no investigations found in literature to refute this assumption. Based on this assumption, some investigations have concluded that the diffusion coefficient can be adequately estimated to be 80 to 90% of the diffusion coefficient of water (Williamson and McCarty, 1976). Siegrist and Gujer (1985), found that the average diffusion coefficient in the biofilm matrix increases with an increase in biofilm thickness. They attributed the increase in the diffusion coefficient to the eddy diffusion in the biofilm matrix close to the biofilm surface.

### 2.6.1 OXYGEN TRANSFER

The nitrifying organisms are obligate aerobes. In order for oxygen to reach the biofilm it is initially transferred through the gas-liquid interface then through the liquid-biofilm interface. It is at this latter interface where biochemical reactions take place in order to facilitate oxygen absorption by the biofilm. The transport of oxygen has been found to be the most limiting biological oxidation processes taking place in fixed-media biofilms (Mehta *et al.*, 1972).

Logan (1993) found that oxygen transfer in organic removal TFs and NTFs was not adequately accounted for in various publications. A numerical solution model for oxygen utilisation in fixed biofilms has hence been developed by Logan (1993). The following conclusions have been established from the numerical oxygen transfer model by Logan (1993);

- Cross-flow plastic media is more superior in oxygen transfer efficiency in comparison to vertical-flow media. This finding is also in agreement with the following authors Parker *et al.* (1989); Logan (1993); Parker and Merrill (1984) and Lutz *et al.* (1990).
- Cross-flow media with a density of  $138 \text{ m}^2/\text{m}^3$  was found to be more efficient in oxygen transfer than cross-flow media with a density of  $96 \text{ m}^2/\text{m}^3$ . This may imply that high density media, which exhibits a bigger media specific surface area, results in higher oxygen transfer rates. However, oxygen transfer is not a linear function of surface area as the first statement would imply but rather of the biofilm depth (Logan, 1993).
- Maximum nitrification rates are insignificantly affected by the type of kinetic rate model used

- Oxygen flux is limited by oxygen transport through the thin biofilm (i.e. oxygen gradient). Thus an increase in oxygen transfer is due to an increase in oxygen diffusivity and a decrease in biofilm thickness.
- Temperature was predicted to not substantially affect the maximum oxygen transfer rates. Changes in diffusion coefficients and fluid thickness were deemed to have a more significant contribution to maximum oxygen transfer rates than the effect of changes in temperature.

This organic COD-based numerical oxygen transfer model by Logan (1993) has been successfully applied to NTFs by Parker *et al.* (1989). However, it is not clear if this model is also applicable to rock media NTFs.

Gullicks and Cleasby (1990) proposed that the secondary effluent, influent to the NTF, could be aerated prior to application onto the plastic media in an attempt to decrease the required media specific surface area. However, Logan and Parker (1990) refuted this statement. They claim that the influent dissolved oxygen (DO) concentration is an insignificant design parameter because the DO gradient in thin biofilms is rapidly established and it is this gradient that ultimately limits the oxygen flux to the biofilm. Logan (1993) conducted an experiment to determine the effect that the presence or absence of oxygen in the influent TF has on the overall oxygen transfer rate. It was found that the DO concentration profiles were approximately identical along the depth of the biofilm in both cases, thus corroborating the argument by Logan and Parker (1990).

Williamson and McCarty (1976) found that in order to avoid oxygen flux limited conditions the DO concentration would have to be 2.7 times the ammonia concentration. They also proposed that the oxygen flux limitation problem could be overcome by diluting the ammonia concentration with the recycling of the NTF effluent or by increasing the DO concentration with pure oxygen.

### 2.6.2 SUBSTRATE CONCENTRATION

The substrate in the bulk liquid reaches the biofilm via diffusion through the liquid-biofilm interface. At effluent ammonia concentrations  $> 5$  mgN/l, the substrate uptake rate is zero order and oxygen-limited. Such conditions enhance homogenous biofilm development. The substrate uptake rates are first order and ammonia-limited when the effluent ammonia concentration is  $< 5$  mgN/l. Conversely, such conditions result in patchy biofilm growth as there are insufficient substrate concentrations at the lower depth of the TF media for homogenous biofilm development. The decline of nitrification rates with depth can be explained by any of the following; non homogenous biofilm growth as a result of low or varying influent ammonia concentrations, insufficient oxygen or a lack of complete media wetting.

The substrate uptake is temperature dependent and will hence result in deeper biofilm development under warmer temperatures.

### 2.6.3 ALKALINITY LIMITATION

The process of nitrification produces acidity (equation 2.1) or equivalently, consumes alkalinity and produces  $\text{CO}_2$ . As mentioned before, nitrification rates take place in a pH range of 7.0 - 8.5 with sharp declines in rate outside this range. The consumption of alkalinity may drop the pH to levels outside of the optimum range, which will consequently decrease nitrification rates and result in a decline of nitrification rates with depth. Siergrist and Gujer (1987) found that for non alkalinity limiting conditions to prevail, the residual alkalinity should be  $>75\text{mg/l}$  as  $\text{CaCO}_3$ . The residual alkalinity was also found to be in the range of 50-100 and 75-100 mg/l as  $\text{CaCO}_3$  by Gujer and Boller (1984) and Boller and Gujer (1985a) respectively. This means that the required influent alkalinity must be predicted from the maximum inlet ammonia concentration in order to ensure that there is sufficient alkalinity for maximum nitrification. Equation (2.3) by Boller and Gujer (1986a) can be used to estimate the required influent alkalinity.

$$\text{Influent alkalinity} \geq 1.5\text{-}2.0 \text{ m-equiv/L} + 0.14(\text{m-equiv/mg N}) * [s_{\text{N,b}} (\text{influent}) - s_{\text{N,b}} (\text{effluent})] \quad (2.3)$$

Where; 1m-equiv/L = 1mM = 50mg/l as  $\text{CaCO}_3$

$s_{\text{N,b}}$  = ammonia concentration in mgN/l

## 2.7 OPTIMUM OPERATING CONDITIONS FOR EFFICIENT TERTIARY NITRIFYING TRICKLING FILTER PERFORMANCE

This section discusses the practical application of nitrification in NTFs by considering the identified operating variables that ensure optimum operating conditions in NTFs. It also discusses the threshold secondary effluent concentrations that are required for efficient biofilm growth and hence maximum nitrification rates.

### 2.7.1 TYPE OF MEDIA

The initial application of TFs for organic COD removal made use of rock media. Over the past 30 years, the use of plastic media became more prevalent. The characteristics and advantages of both media types are discussed below.

### 2.7.1.1 Rock media

The rock media TF heights are typically 1 to 2 m (Logan *et al* 1987). They are usually filled with spherical rocks of varying sizes to give correspondingly varying area to volume ratios with a typical specific media surface area of approximately 45 m<sup>2</sup>/m<sup>3</sup>. In South Africa, rock media TFs are predominantly found in old treatment plants that have been extended with BNRAS systems.

The first rock media NTF data was collected by National Research Council (NRC) on military wastewater treatment plants during the World War II (Parker *et al.*, 1986). Parker *et al.* (1986) found rock media to be just as efficient as plastic media in the oxidation of ammonia provided that the loading is expressed on ammonia mass removed per *unit surface area* of media basis rather than a *volumetric* basis.

### 2.7.1.2 Plastic media

There are various types of plastic media which range from vertical-flow, hybrid and custom designs, randomly packed, to cross-flow. The angle of inclination of the plastic media sheets may also vary per media configuration. Plastic media exhibit a wide range surface area to volume ratio, with values reported in the literature, ranging from 90 to 240 m<sup>2</sup>/m<sup>3</sup>.

### 2.7.1.3 Media efficiency in the application of tertiary nitrifying trickling filters

High specific surface media can be efficiently used in NTFs due to low nitrifier biomass yield of the nitrification process. However, high density media have a significantly higher flow interruption per unit media surface area and are hence more prone to trapping suspended solids and thus resulting in dry patches throughout the media (Parker *et al.*, 1989 and 1995). The findings by Parker *et al.* (1989, 1995) are supported by Boller and Gujer (1985) and they have recommended that a plastic media with specific surface area range of 150-200 m<sup>2</sup>/m<sup>3</sup> is better suited for tertiary NTFs.

It has been found that cross-flow media have a superior performance efficiency compared to vertical-flow media for the same specific surface. Vertical-flow plastic media have been found to be less efficient than both rock and cross-flow media in a *pilot* plant investigation by Parker *et al.* (1986). However, Lutz *et al.* (1990) found that there was no significant difference in performance between cross-flow, vertical-flow and hybrid configurations at *full-scale* facilities. They found that the superior oxygen transfer characteristics of cross-flow media was not apparent because they were not able to differentiate media type by nitrification efficiency. They attributed this to ammonia loading rates that were insufficient to produce oxygen flux limited conditions. Hence it is essential that all other parameters required for maximum nitrification rates are met in order to take advantage of the superior oxygen transfer characteristic of cross-flow media.

Plastic media TFs offer many physical advantages over rock media TFs, namely; permissible tower heights of 1 to 12m, high voids which allows for more efficient transfer of oxygen throughout the media, low media mass and also that plastic media occupy a smaller volume of the voids.

### 2.7.2 INFLUENT ORGANIC CONCENTRATION

According to a review by Parker *et al.* (1986), Wanner and Gujer produced a model that describes species competition at any layer in the biofilm. It has been found that nitrifiers are unable to compete in the upper regions of TFs because high organic COD concentrations enhance the growth of faster-growing heterotrophic bacteria which deplete the oxygen near the top of the media. Consequently nitrifiers grow in the lower depths of TFs media where soluble organic biodegradable COD concentrations are negligible and oxygen can penetrate through to the nitrifying biofilm.

The model by Wanner and Gujer also predicts that nitrifying organisms can compete successfully only when the threshold COD concentration is below 27 mgCOD/l (Parker *et al.*, 1986). At a pilot plant investigation by Parker *et al.* (1986) the threshold concentration was found to be between 27 and 30 mgCOD/l. However, it is not clear whether the threshold concentrations that have been published are the total soluble COD concentration or the soluble biodegradable concentration i.e. soluble COD concentration degraded in the NTF.

Parker *et al.* (1990) claimed that organic loads on NTFs can be as high as 2 kg BOD<sub>5</sub>/m<sup>3</sup>.d at full-scale operation. They ascribed the high organic loads to the improvements in the efficiency of design units such as flocculator-clarifiers and cross-flow plastic media. The improved clarifier designs produce secondary effluent that has negligible TSS concentrations.

### 2.7.3 INFLUENT TOTAL SUSPENDED SOLIDS CONCENTRATION

The influent TSS concentration to NTFs has to be virtually zero in order to ensure optimum operating conditions in the TF. High TSS concentrations clog the TF media which retards the hydraulic pathway through the media and reduces the surface area available for nitrifier biofilm attachment. The soluble biodegradable COD content in the solids may also result in heterotrophic activity which has a negative effect on the growth of the nitrifying biomass.

Boller and Gujer (1985b) found that on a pilot plant investigation, TSS concentrations of 1-2 mgTSS/l allowed for nitrification to start at the top of the TF. At full-scale, Lutz *et al.* (1990) found the threshold TSS concentration to be approximately 15 mgTSS/l. They found that at concentrations > 20 mgTSS/l nitrification rates were impaired and this resulted in higher effluent ammonia concentrations. They attributed the increase in TSS loading on the NTFs to occasional system upsets to the wastewater treatment plant primary and secondary units. These upsets could either be operational or as a consequence of peak wet weather conditions. Peak wet weather conditions, above the clarifier design criterion, result in shorter clarifier retention times due to the higher hydraulic loading rates and consequently solids carry over to the NTF.

Gujer and Boller (1984) found that tertiary NTFs produces very little TSS. They estimated that the nitrification of 20 mg/l of ammonia yields approximately 2 mgTSS/l of nitrifying organisms, thus there is no need for a tertiary clarifier after the NTF unit.

Facultative aerated operated lagoons, such as the case at the Citrusdal WWTP (the site of this research investigation), should also theoretically produce negligible TSS concentrations. In such lagoons, there is insufficient mixing energy to keep the suspended solids in suspension, thus a sludge layer forms at the bottom of the lagoon. The secondary effluent at the CWWTP comes from the unaerated zone which has no mechanical mixing. However, oxidation ponds are notorious for prolific algal growth during warm water temperatures. Hence, higher TSS concentrations are anticipated during such periods.

#### 2.7.4 INFLUENT AMMONIA CONCENTRATION

Full-scale domestic wastewater treatment plants are subjected to significant influent ammonia load variations over a 24 hour period. This means that at low influent ammonia concentrations, the lower depth of the TF media is ammonia limited. Hence, the entire media is only adequately exposed to bulk ammonia concentrations during peak ammonia loading conditions. As a result of this, NTFs may exhibit biomass growth that is slow, thin and patchy.

Diurnal ammonia load variation on NTFs results in a decrease of nitrification rates with depth due to patchy biofilm growth. Experiments by Boller and Gujer (1985b) have shown a relatively linear relationship of ammonia concentration with depth under varying ammonia loads in the top regions of the NTF. This indicates that there is constant biomass activity under diurnal ammonia load variations in the top regions of the TF. However, the relationship of ammonia with depth, in the lower regions of the tower, showed a curved profile under different ammonia concentrations (Boller and Gujer, 1985b). This indicates that the biomass activity is not constant under diurnal ammonia load variations in the lower depths of the TF, and implies that the biofilm growth is non-homogenous and thin in these regions.

Due to diurnal ammonia load variation, the NTF could be operating at zero order rates with respect to ammonia in the top regions of the NTF and at first order rate (ammonia-limited) in the lower regions. Operation of NTFs under zero order rates is indicative of homogenous biomass activity throughout the total depth of the TF. Boller and Gujer (1984, 1985b) suggested that the following measures can be taken in order to ensure that zero order rate conditions prevail throughout the entire depth of the NTF;

- i) Dosing the TF influent flow with  $\text{NH}_4$  during low ammonia loads on the TF.
- ii) Digester supernatant can be recycled during periods of low ammonia loads. They suggest that this may increase the daily load by 10-20%. The viability of this option depends on the treatment plant operation configuration.
- iii) Operating two TFs in series (two-stage operation) and regularly switching lead and follow TFs (every 1 to 2 weeks).

The option of introducing a chemical dosing system to the NTF at Citrusdal NTF is not possible due to limited plant operator experience and skill to efficiently implant such a system. The second option of recycling ammonia would not be applicable to the aerated facultative lagoon operated system at Citrusdal. There is only one NTF on site however; the hydraulic loading rate on the NTF can be increased by introducing a TF effluent recycle which has the same effect as operating two TFs in series.

### 2.7.5 VENTILATION

Oxygen is a requirement for nitrification to take place. Most TFs rely on natural convection to achieve media aeration (Lutz *et al.* 1990). It is this 'free' aeration that also makes external nitrification in BNRAS with the use of TFs economically attractive. However, in research on the full-scale performance of NTFs by Lutz *et al.* (1990), it has been found that forced ventilation is sometimes required to achieve optimal nitrification performance on a year-round basis.

The provision of extra ventilation is mostly in the form of forced-air fans. The fans can either be installed on the roof or the sides of the NTF depending on the design of the trickling filter. During their investigation, Lutz *et al.* (1990) found the following types of fan configurations installed at full-scale operated NTFs;

- i) Roof fans which augment natural air convection by drawing untempered outside air through the media
- ii) Fans situated below the media which supply air centrifugally through the TF (this is the type of configuration that was installed at the Citrusdal NTF).
- iii) An intricate system of fans which distributes air inside the dome covers of the TF and discharges air that is collected beneath the media to the atmosphere.

### 2.7.6 HYDRAULIC LOADING RATE

Hydraulic loading rate (HLR m/hr) on NTFs is expressed as the total influent flow (including recirculation) divided by the cross sectional area of the TF. Poor HLRs lead to the development of patchy dry areas on the TF media. These dry areas are suitable for the development of filter fly larvae which feed on the nitrifying biomass. Consequently, biofilm grazing by the filter fly larvae decreases nitrification rates. Wetting rates can be increased by recirculation or by making use of a two-stage operation system (operating two TFs in series). The two-stage operation system is discussed in the latter sections of literature review. The minimum HLR required to decrease filter fly larvae to insignificant amounts has been found to be 3 m/hr by Boller and Gujer (1986b) and Parker *et al.* (1989).

Gullicks and Cleasby (1990) found from their cold weather investigation, that poor nitrification rates prevailed under total hydraulic loading rates greater than 3.0 m/hr and that there was a marked improvement in the nitrifying performance of the NTF at hydraulic rates (excluding recycle) lower than 3.0 m/hr. This is similar to the findings by Logan *et al.* (1987a) on their investigation on carbonaceous

TFs. Logan *et al.* (1987a) claimed that recycling TF effluent can increase the organic removal performance as well as decrease it. There have been no other findings from the investigations reviewed to corroborate or refute the findings by Gullicks and Cleasby (1990) and Logan *et al.* (1987a).

### 2.7.7 AMMONIA LOADING (ALR) AND NITRIFICATION RATES (ANR)

The hydraulic loading rate (HLR) is expressed as the influent flow rate divided by cross section area of the media.

$$\text{HLR} = \frac{Q_i}{A_{cs}}$$

The recirculation flow rate has not been included in the HLR calculation or in calculating influent and effluent ammonia mass. This is because it has been assumed that the recirculation flow is internal to the system which is demarcated by the dashed line in Figure 2.2. There for in order to simplify the apparent calculations, only parameters entering ( $Q_i$  and  $N_{ai}$ ) and exiting ( $Q_e$  and  $N_{ae}$ ) have been considered.

Ammonia loading rate (ALR) is defined as the mass of influent ammonia per total media surface area (see Figure 2.2). The total media surface area is calculated by multiplying the specific surface of media ( $A_{sp}$  -  $m^2/m^3$ ) with the volume of the media ( $V_m$ ).

$$\text{ALR} = \frac{Q_i * N_{ai}}{V_m * A_{sp}}$$

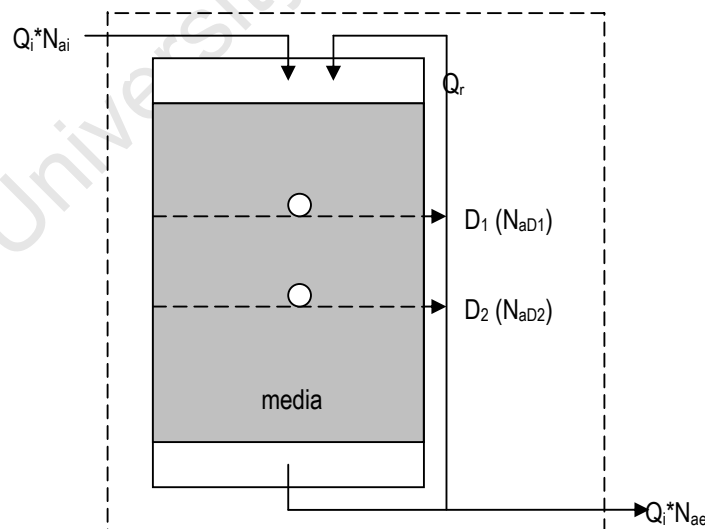

Figure 2.2: Definition of hydraulic loading rate (HLR), ammonia loading rate (ALR), apparent ammonia nitrification rate (ApANR) and actual ammonia nitrification rate (AcANR)

The apparent ammonia nitrification rate (ApANR) is the mass of the ammonia removed by the NTF per total media surface area (see Figure 2.2).

$$\text{ApANR} = \frac{Q_i * N_{ai} - Q_e * N_{ae}}{V_m * A_{sp}}$$

Actual ammonia nitrification rates (AcANRs) are calculated by using profile ammonia samples. In this report, the AcANRs have been calculated as the mass of ammonia removed between two sampling ports per total media surface area between the sampling ports (see Figure 2.2). The calculated AcANR is then associated with the midpoint of the two sampling ports.

$$\text{AcANR} = \frac{Q_i * (N_{ad1} - N_{ad2})}{(D_1 - D_2) * (A_{cs}) * A_{sp}}$$

No models have been used to predict the nitrification rates expressed in this report.

## 2.7.8 PREDATION

In many of the experiments that have been found in the literature reviewed, there has been a significant prevalence of macrofauna. The reproduction of macrofauna is dependent on the availability of food, favourable temperatures and the capability to withstand hydraulic action of the influent flow. The types of macrofauna that has been found in NTFs are mainly; snails, worms and filter fly larvae.

### 2.7.8.1 Filter fly larvae

Filter fly larvae develop on the dry patches on the TF media and feed off the nitrifying biofilm. During heavy grazing by the larvae, nitrification rates have been known to be very severely impaired and in some cases to cease completely (Boller and Gujer, 1986b, Parker *et al.*, 1997 and Lutz, 1990).

Fly larvae control in rock media organic removal TFs has been done by chlorination. However, chlorination has been rejected because of its toxicity to nitrifiers (Parker *et al.*, 1989). High HLRs improve the wetted media specific surface area and accordingly, dry media patches are eradicated and the proliferation of filter fly larvae is eliminated.

Lutz *et al.* (1990) found numerous methods of predator control that were employed at full-scale plant operations in their paper that summarises the full-scale performance of NTFs in the USA. At one plant, electric fly traps were installed to attract and kill adult flies inside the NTF enclosure. The operators at the site found the method to be successful. At a rock media plant, the NTF was saturated with malathion insecticide once a month and the secondary clarifiers were sprayed on average every two weeks. The rock trickling filter was occasionally dosed with chlorine to supplement the insecticide.

Regular flooding or backwashing has been found to eliminate predator infestation in plastic media NTFs. Regular backwashing also controls biomass inventory so that repetitive sloughing events do not occur (Parker *et al.*, 1989). TSS in the NTF could also be removed by regular backwashing. However, the efficiency of controlling high influent TSS levels by backwashing is uncertain (Parker *et al.*, 1989). The Citrusdal NTF is not designed to allow for flooding or backwashing.

### 2.7.8.2 Worms

In a pilot-scale NTF operation investigation carried out by Boller and Gujer (1985b), a significant presence of the worm species *Naididae* was found. This species was found in significant numbers in the areas of the TF where the biofilm was well developed. Although the worms were found to affect the level of nitrification rates, they did not cause serious fluctuations in the performance of the NTF. The authors inferred from this that the biofilm and the worms grow symbiotically. In other words, stable nitrification rates are maintained with the grazing of the worms reaching some sort of equilibrium with the biofilm growth.

Andersson *et al.* (1994) found that high chloride levels negatively impacted the *Naididae* species. However, Parker *et al.* (1989) have rejected the use of chlorine for its toxic effect on the nitrifying biomass. The *Naibarbata* of the *Naididae* worm species has been found to be sensitive to salt during a pilot-scale investigation by Parker *et al.* (1995). They found that flooding the NTF with a brackish water solution decreased the amount of worms with no effect on nitrification rates.

### 2.7.8.3 Snails

Snails are mainly found in rock media NTFs. They have been found to be the most troublesome predators to eradicate. Jenkins *et al.* (2000) have developed a nitrification tower-dosing scheme for snail removal. The NTF tower is isolated monthly and dosed with high ammonia concentration centrate with a pH in the range of 9.0 to 9.5 obtained with sodium hydroxide. Tests showed that the ammonia containing centrate is effective in killing both the adult snails and their eggs without compromising the nitrification capacity of the tower (Jenkins *et al.*, 2000). The tower is then flushed with secondary effluent for approximately 10 hours before it is returned to service.

An alkaline dosing method, which presumably was similar to the method developed by Jenkins *et al.* (2000), was reported in a research review and full-scale application of the performance of NTFs by Parker *et al.* (1997). It was found that at pH 10 the snails were greatly reduced but to the detriment of reduced nitrification rates. They attributed the drastic decline in nitrification rates to the high pH of 10 having a toxic effect on nitrifiers. This reasoning is valid because the optimum pH range for nitrifying biomass growth is 7 to 8.5 with sharp declines in nitrification rates outside of this range. Parker *et al.* 1997 found that significantly more macrofauna was removed at a pH of 10 than at a pH of 9. At a pH of 9 they found nitrification rates to steadily start increasing. The alkaline backwash was only performed once every month for three months after which it was no longer required.

## 2.7.9 THE EFFECT OF WASTEWATER TEMPERATURE

NTF performance is affected by the seasonal change in temperature. Nitrification rates are generally higher during the warm climate due to higher reaction rates per unit surface area (Boller and Gujer, 1986a, Lutz *et al.*, 1990). Replacement of biofilm, from the continual loss through predation and sloughing, is also much better during warmer temperatures (Parker *et al.*, 1995).

The large void to volume fraction of plastic media presents only a small resistance to airflow through the media. This may result in considerable cooling of treated wastewater through the NTF. Gujer and Boller (1984) have suggested that the constriction of air-flow into the NTF during the winter periods can be considered if plastic media of a low specific surface area is used. However, both Gullicks and Cleasby (1990) and Logan and Parker (1990) found the restriction of air-flow in order to maintain warmer temperatures in the winter to be unnecessary. The effects of small changes in temperature (1-2 °C) are less detrimental to oxygen mass transfer than the decrease in nitrification rates that would result from reduced ventilation (Gullicks and Cleasby, 1990). In cold climate, the biological reactions that take place in treatment plants are generally slower. This impairs the biological treatment capacity of operating units and hence continued biological reactions take place in intermediate clarifiers consequently depleting DO concentrations (Gullicks and Cleasby, 1990). The combination of this and reduced diffusion rates of DO from the bulk liquid to the biofilm further reduce oxygen mass transfer into the biofilm under cold climate conditions. Gullicks and Cleasby (1990) also concluded that the diffusion of oxygen (when effluent ammonia concentrations are > 5 mgN/l – non ammonia limiting conditions) through liquid and the biofilm had the greatest effect on the supply and consumption of oxygen to the biofilm and hence on the nitrifying capacity of the biofilm during the cold climate.

The Gullicks and Cleasby (1990) paper is an account of a pilot-scale investigation of the performance of NTFs in cold climate. Data was collected from a NTF packed with a 60 degrees cross-flow media with a media density of 138 m<sup>2</sup>/m<sup>3</sup> for wastewater temperature range of 8-25°C. They found nitrification rates in the cold climate to be highly dependant on the total HLR and wastewater application method. Intermittent ammonia dosing and HLRs exceeding approximately 2.9 m/hr were found to be detrimental to the performance of the pilot-scale NTF. They found this to be case in spite of low influent soluble organic COD concentrations. Nitrification performance was only restored at lower hydraulic loading rates of 2.2 m/hr with continuous dosing of ammonia.

According to Parker *et al.* (1986) empirical data needs to be collected for lower wastewater temperatures. There is mostly data collected for temperatures ranging between 10 and 21 °C (Parker *et al.*, 1990). Data collected at higher temperatures can be converted to represent nitrification rates at lower temperatures by using equations based on the Ernst-Einstein equation. However, the reliability of the converted data in accurately representing nitrification rates at lower temperatures is questionable. The often simplified temperature conversion equations {such as  $r_T = r_{20} (\theta)^{(T-20)}$ } do not take into account physical parameters such as media types and configurations and microbial temperature dependent variables that affect the nitrification process.

### 2.7.10 TWO-STAGE OPERATION OF NITRIFYING TRICKLING FILTERS

In order to overcome non-homogeneous biofilm growth, NTFs can be operated in series (two-stage) rather than in parallel (single-stage). The same effect can be accomplished by recirculating the NTF effluent. Two-stage operation requires that the lead tower of the two trickling filters be alternated periodically in order to achieve homogenous biomass growth in both filters. The lead tower should be alternated roughly every 7-14 days (Gujer and Boller, 1984).

Parker *et al.* (1995) conducted experiments to show the superior nitrifying capacity of two-stage TF operation. The results that they obtained are presented in Table 2.1. Modes 1 and 3 refer to single- and two-stage operation respectively. In two-stage TF operation, each trickling filter was loaded at a HLR of 2.5 m/hr thus giving a total loading rate of 5 m/hr to system. The lead NTFs were alternated weekly during the experiment. Periods 1 and 2 indicate the NTF performance during high ammonia loading rates (ALRs) and Periods 3 and 4 shows the NTF performance under low ammonia loading conditions. It is evident that nitrification rates improved considerable under higher ALR conditions regardless of the of the TF operating sequence. Higher nitrification and much lower effluent ammonia concentrations were achieved with two-stage NTF operation.

**Table 2.1: NTF experimental performance (Parker *et al.*, 1995)**

Parameter	Units	Period1	Period 2	Period 3	Period 4
		Mode1	Mode 3	Mode 1	Mode 3
HRL <sup>1</sup>	m/hr	2.5	5.0	2.5	5.1
Temp	°C	17.8	15.0	17.6	13.4
ALR <sup>2</sup>	gN/m <sup>2</sup> /d	2.5	2.4	1.9	19
ANR <sup>2,3</sup>	gN/m <sup>2</sup> /d	1.6	2.1	1.6	1.8
N <sub>inf</sub>	mgN/l	20.6	19.6	15.6	15.3
N <sub>eff</sub>	mgN/l	7.0	2.4	1.6	0.4

<sup>1</sup> in m<sup>3</sup>/hr pr m<sup>2</sup> TF cross-section area (see Figure 2.2)

<sup>2</sup> in gFSA – N/d per m<sup>2</sup> media surface area

<sup>3</sup> apparent ammonia nitrification rates

A decline in nitrification rates which is associated with patchy biofilm growth was found to be strong in the results obtained from a single-stage operated NTF by Parker *et al.* (1995). Figure 2.3 by Gujer *et al.* (1994) illustrates this decline in nitrification rates with depth (the depth effect). This is indicated by the significant difference in nitrification rates between the four different depths, with nitrification rates decreasing from top to bottom.

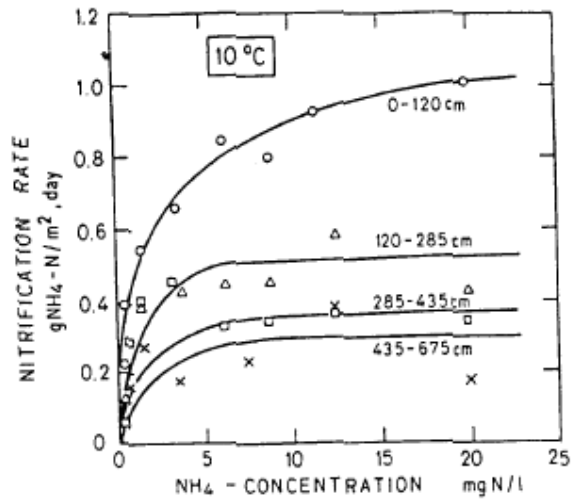

**Figure 2.3: Single-stage operation nitrification rates as function of depth**

SOURCE: Gujer et al. 1994

In contrast, two-stage TF operation results in a more homogeneous biofilm growth throughout the TF media depth and a less prominent depth effect. This is illustrated in Figure 2.4 where the difference in nitrification rates with depth is not as substantial as illustrated in the single-stage operated TF in Figure 2.3.

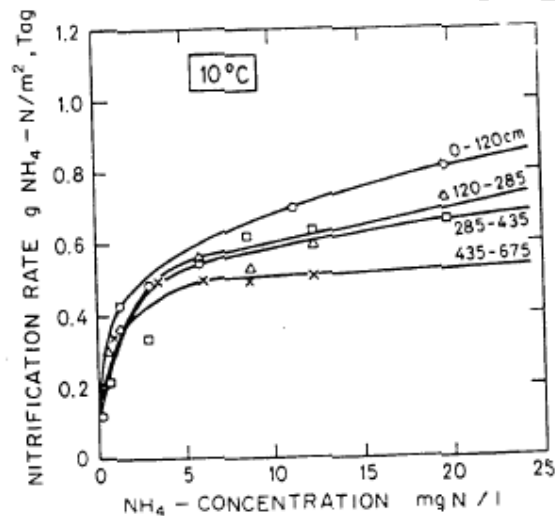

**Figure 2.4: Two-stage operation nitrification rates as function of depth**

SOURCE: Gujer et al. (1994)

In short, the following operating variables have to be accounted for in order to create an environment in the NTF that is conducive to maximum biofilm growth;

- i) good secondary effluent quality that has negligible concentrations of TSS and low soluble biodegradable COD and a high ammonia concentrations.

- ii) high HLRs to eradicate filter fly larvae and to ensure a good media wetting and hence homogenous biofilm growth
- iii) regular flooding or backwashing for predator control
- iv) adequate ventilation to avoid oxygen flux limited conditions

## 2.8 NITRIFICATION RATES IN TERTIARY NITRIFYING TRICKLING FILTERS

The oxidation of ammonia in NTFs is quantified as the mass of ammonia removed per surface area of the media ( $\text{gN/m}^2\text{d}$ ). There are two types of nitrification rates, namely; apparent and actual ammonia nitrification rates (ANR).

Apparent nitrification rates (ApANRs) are based on influent and effluent ammonia concentration values to the NTF (Figure 2.2). It does not account for the internal biochemical processes and limitations to the nitrifying capacity of the biofilm patchy biofilm or dry media areas. Apparent nitrification efficiency is determined by the expressing the mass of ammonia removed by the NTF as a percentage of the influent mass of ammonia.

In contrast, actual ammonia nitrification rates (AcANRs) are calculated by using the difference in the mass of ammonia removed between two sample points along the TF media depth (Figure 2.2). These determined rates are then associated with a point equidistant between the two sampling points (Parker *et al.*, 1989). Hence, in order to calculate actual nitrification rates, sampling along the NTF depth is required, which is not the case in the calculation of apparent nitrification rates. Furthermore, actual nitrification rates are only calculated for conditions where the bulk ammonia concentration exceeds 5  $\text{mgN/l}$  (oxygen flux limited conditions). The reason for this is that the biofilm model which can be used as a guide to measure and predict actual nitrification rates is generally only applicable under oxygen flux limited conditions.

The results presented in Table 2.2 indicate maximum nitrification rates achieved when all of the relevant and applicable operating variables, which have been discussed in the literature review, are taken into account. The different NTF media are compared on a unit surface area performance basis. In comparing the full-scale operation of two-stage operated NTFs by Parker *et al.* (1997) and Muller *et al.* (2006) it can be seen that the ApANRs of rock media compares very well at 1.25  $\text{gN/m}^2\text{d}$  compared to 1.68 and 1.27  $\text{gN/m}^2\text{d}$  achieved on the plastic media. At pilot scale, nitrification rates of 2.3 and 2.1  $\text{gN/m}^2\text{d}$  for single- and two stage operations respectively have been achieved. These rates are higher than the published full-scale results in Table 2.2. This is expected because of the controlled nature of pilot-scale investigations. Higher ApANRs were obtained with single-stage operation than two-stage in the investigations summarised in Table 2.2. However, the single-stage operated NTF produced an effluent ammonia concentration of 14  $\text{mgN/l}$  (Parker *et al.*, 1989) compared to effluent concentrations of less than 3  $\text{mgN/l}$  (Parker *et al.*, 1995 and 1997 and Muller *et al.*, 2006) that were achieved under two-

stage NTF operation investigations. This shows the higher nitrification efficiency of two-stage NTF operation in achieving low effluent ammonia concentrations while maintaining homogeneous biofilm growth compared with single-stage operation.

**Table 2.2: Summary of maximum nitrification rates published in the literature reviewed**

Parameter	Unit	SOURCE				
		Parker <i>et al.</i> 1989	Parker <i>et al.</i> 1995	Parker <i>et al.</i> 1997	Parker <i>et al.</i> 1997	Muller <i>et al.</i> 2006
Research type		Pilot-scale	Pilot-scale	Full scale	Full scale	Full-scale
No. of NTFs		1	2	2	2	2
NTF height	m	6.7	3.6	7.3	7.3	3.6
Media type		Plastic CF	Plastic CF	Plastic CF	Plastic CF	Rock
Media density	m <sup>2</sup> / m <sup>3</sup>	132	140	138	138	45
Total media surface area	m <sup>2</sup>	1 274	3 563	810 199	810 199	115 560
Temperature	°C	15	15	16.5	20.3	22.4
HLR	m/hr	5	5*	4*	4*	2.6*
ALR	gN/m <sup>2</sup> d	np	2.4	1.68	1.35	1.44
ANR <sup>a,b,c</sup>	gN/m <sup>2</sup> d	2.3 <sup>b</sup>	2.1 <sup>a</sup>	1.68 <sup>a</sup> (1.73) <sup>c</sup>	1.27 <sup>a</sup> (2.34) <sup>c</sup>	1.25 <sup>a</sup>
Eff. ammonia conc.	mgN/l	14	2.4	1.85	1.56	2.37
Ammonia removed	mgN/l	16	17.2	24.8	19.4	14.8
Influent COD conc.	mgCOD/l	7.6	9.9 <sup>§</sup>	1.13 <sup>†</sup>	11.85	88.6
Effluent COD conc.	mgCOD/l					93.9
Influent TSS conc.	mgTSS/l	7.7	16.0	10.22	14.8	31.7

a = Apparent nitrification rates, b = Actual nitrification rates calculated using theoretical NTF models and c = Average nitrification rates calculated by only considering oxygen-limited region NTFs

CF = cross-flow

\* The sum of the equal HLRs applied to each NTF

§ 9.9 BOD<sub>7</sub> mg/l

† 1.13 CBOD<sub>5</sub> mg/l

The maximum ApANRs (see Table 2.2) have been achieved using plastic media with a specific density that was in the recommended range of 150-200 m<sup>2</sup>/m<sup>3</sup> (Boller and Gujer, 1985). The height of the NTF

doesn't appear to contribute significantly to the maximum achieved nitrification rates. At a height of 3.6 m (140 m<sup>2</sup>/m<sup>3</sup>) ApANR of 2.1 gN/m<sup>2</sup>d were achieved compared to 2.3 and 1.68 gN/m<sup>2</sup>d for heights of 6.7 m (132 m<sup>2</sup>/m<sup>3</sup>) and 7.3 m (138 m<sup>2</sup>/m<sup>3</sup>) respectively.

For most of the NTF operations summarised in Table 2.2 the HLRs exceeded the minimum requirement of 3 m/hr for predator control and adequate media wetting. With the rock media NTF, comparably good ApANRs were achieved at a HLR of only 2.6 m/hr (1.3 m/hr for each trickling filter).

The experimental and full-scale maximum nitrification rates have been obtained at temperatures ranging from 10.9 to 22.4°C. It would be a good contribution to literature to investigate the operating efficiencies of NTFs at temperatures lower than 10°C rather than using equations to convert ApANRs obtained at higher temperatures to the lower temperatures of interest. In this manner the effect that temperatures below 10°C have on the internal bio-kinetics of the nitrifying biofilm can be experimentally observed. Hence it can also be experimentally verified whether increased HLRs improve nitrification rates at low temperatures.

Nitrifying trickling filter models have been developed as a guideline for NTF design. The rationale behind these models can be divided into two categories, namely; empirical models which are based on ApANRs in NTFs and the theoretical approach which require actual nitrification rates (AcANR). A detailed summary of the development of both these schools of thought can be found in Appendix A.

## 2.9 SUMMARY

The purpose of this literature review has been to elucidate the findings on the optimum operating conditions required for maximum nitrification rates in NTFs. The following is a summary of the operating variables that have to be met in order to create an environment that is conducive to the development of deep biofilms, high nitrification rates and better removal efficiencies in NTFs;

- Maximum influent TSS concentration of approximately 15 mgTSS/l (Lutz *et al.* 1990). High suspended TSS concentrations lead to clogging of the media, which impairs the hydraulic pathway through the media concerned. Hence an internal clarifier is required to ensure negligible influent TSS load on the TF
- Influent soluble biodegradable COD concentration should be approximately 27-30 mgCOD/l (Parker *et al.*, 1986). High organic loads have a negative impact on nitrification rates.
- A minimum HLR of 3 m/hr is required for the elimination of filter fly larvae (Boller and Gujer 1986b, Parker *et al.*, 1989). This can be obtained by recirculating NTF effluent or by using two-stage TF operation.
- NTFs are susceptible to invasions of predators such as; snails, worms and filter flies. Worms and filter flies can be controlled by regular flooding and backwashing (Parker *et al.*, 1989). Snails can be eradicated by alkaline flooding (Parker *et al.*, 1997 and Jenkins *et al.*, 2000). The long term effect of this eradication method has a negative impact on nitrification rates.

- Natural convective air supply has been found to be inadequate, especially during the warmer seasons when kinetic rates are faster. Fans should be installed to increase the oxygen supply to the NTF.
- Full-scale NTFs are subjected to diurnal ammonia load variation. To ensure homogeneous biofilm growth; NTFs should be operated in series with ammonia dosing during periods of low influent ammonia loads – which can be done by recycling ammonia rich anaerobic digester supernatant or introducing an ammonia dosing system.
- The biological nitrification process consumes alkalinity. Hence necessary measures should be taken to ensure that there is sufficient influent alkalinity (effluent alkalinity > 75 mg/l as CaCO<sub>3</sub>).
- It is preferable for NTFs to operate under oxygen limiting conditions with effluent ammonia concentrations > 3-5 mgN/l for homogeneous biofilm development. If lower effluent ammonia concentrations are required, NTFs can be operated in series with the lead and follow TFs being alternated approximately every 7–14 days.
- Plastic media are more superior due to their significantly higher specific surface (3 to 4 times higher than rock) and void ratio resulting in greater efficiency of oxygen exchange and effective hydraulic distribution than rock media. Nonetheless, comparably good full-scale media specific nitrification rates have been obtained with a rock media NTF in South Africa (see Table 2.2).
- Optimum range for media specific surface area for plastic media in NTF application has been found to be 150-200 m<sup>2</sup>/m<sup>3</sup> (Boller and Gujer, 1985b).
- There is a wide range of different types of plastic media. Cross-flow media has been found to be the most efficient in the application of tertiary nitrification in NTFs.

## CHAPTER 2: LITERATURE REVIEW: TERTIARY NITRIFYING TRICKLING FILTER PERFORMANCE

<b>2.1</b>	<b>INTRODUCTION</b>	<b>2-1</b>
<b>2.2</b>	<b>NITRIFICATION PROCESS DEFINITION AND REQUIREMENTS</b>	<b>2-1</b>
<b>2.3</b>	<b>DEVELOPMENTS OF THE EXTERNAL NITRIFICATION (EN) CONCEPT</b>	<b>2-2</b>
<b>2.4</b>	<b>EXTERNAL NITRIFICATION IN FIXED MEDIA TRICKLING FILTERS</b>	<b>2-3</b>
<b>2.5</b>	<b>FIXED BIOFILM MODEL</b>	<b>2-4</b>
<b>2.6</b>	<b>MASS TRANSFER IN FIXED BIOFILMS</b>	<b>2-5</b>
<b>2.6.1</b>	<b>Oxygen transfer</b>	<b>2-6</b>
<b>2.6.2</b>	<b>Substrate concentration</b>	<b>2-7</b>
<b>2.6.3</b>	<b>Alkalinity limitation</b>	<b>2-8</b>
<b>2.7</b>	<b>OPTIMUM OPERATING CONDITIONS FOR EFFICIENT TERTIARY NITRIFYING TRICKLING FILTER PERFORMANCE</b>	<b>2-8</b>
<b>2.7.1</b>	<b>Type of media</b>	<b>2-8</b>
2.7.1.1	Rock media	2-9
2.7.1.2	Plastic media	2-9
2.7.1.3	Media efficiency in the application of tertiary nitrifying trickling filters	2-9
<b>2.7.2</b>	<b>Influent organic concentration</b>	<b>2-10</b>
<b>2.7.3</b>	<b>Influent total suspended solids concentration</b>	<b>2-10</b>
<b>2.7.4</b>	<b>Influent ammonia concentration</b>	<b>2-11</b>
<b>2.7.5</b>	<b>Ventilation</b>	<b>2-12</b>
<b>2.7.6</b>	<b>Hydraulic loading rate</b>	<b>2-12</b>
<b>2.7.7</b>	<b>Ammonia loading (ALR) and nitrification rates (ANR)</b>	<b>2-13</b>
<b>2.7.8</b>	<b>Predation</b>	<b>2-14</b>
2.7.8.1	Filter fly larvae	2-14

	2-24
2.7.8.2 Worms	2-15
2.7.8.3 Snails	2-15
<b>2.7.9 The effect of wastewater temperature</b>	<b>2-16</b>
<b>2.7.10 Two- stage operation of nitrifying trickling filters</b>	<b>2-17</b>
<b>2.8 NITRIFICATION RATES IN TERTIARY NITRIFYING TRICKLING FILTERS</b>	<b>2-19</b>
<b>2.9 SUMMARY</b>	<b>2-21</b>
CHAPTER 2: LITERATURE REVIEW: TERTIARY NITRIFYING TRICKLING FILTER PERFORMANCE	23

University of Cape Town

## LIST OF FIGURES AND TABLES

Figure 2.1: Potential substrate profiles within the biofilm	2-5
Figure 2.2: Definition of hydraulic loading rate (HLR), ammonia loading rate (ALR), apparent ammonia nitrification rate (ApANR) and actual ammonia nitrification rate (AcANR)	2-13
Table 2.1: NTF experimental performance (Parker <i>et al.</i> , 1995)	2-17
Figure 2.3: Single-stage operation nitrification rates as function of depth	2-18
Figure 2.4: Two-stage operation nitrification rates as function of depth	2-18
Table 2.2: Summary of maximum nitrification rates published in the literature reviewed	2-20

## CHAPTER 3

# PRELIMINARY FULL-SCALE NITRIFYING TRICKLING FILTER PERFORMANCE

### 3.1 INTRODUCTION

The WRG at UCT embarked on a full-scale investigation on external nitrifying performance of the NTF at the Citrusdal Wastewater Treatment plant (CWWTP) in 2001. This chapter provides background information on the plant operation, the recommendations and alterations that were completed during the period between 2001 and August 2005 and the resulting performance of the NTF at the start of the investigation in September 2005.

### 3.2 BACKGROUND TO THE OPERATION OF THE CITRUSDAL WASTEWATER TREATMENT PLANT (CWWTP)

The Citrusdal wastewater treatment plant (CWWTP) comprises an aerated facultative lagoon, a plastic media nitrification tower and maturation ponds and treats mainly municipal wastewater. It also treats orange pressings waste from a factory that manufactures orange juice. Additionally a truck goes out roughly once a month, and more often if needed, to collect sewage from the surrounding farmlands and communities. Hence, the treatment plant receives strongly variable organic and nutrient loads seasonally during the orange picking season and monthly when the truck collects sewerage from the surrounding communities.

The plant was designed for a maximum treatment capacity of 1ML/d. However, the plant currently receives an average inflow of 2.7 ML/d (peak wet weather flow) and 2.0 ML/d (average dry weather flow). These values are rough estimates from the plant influent flow rate values obtained in 2006. It is clear the treatment plant is operating way beyond its design capacity.

A layout of the facultative aerated lagoon treatment plant is illustrated in Figure 3.1. The unit operations of the lagoon and the nitrifying TF are discussed in detail. The other plant unit operations are not discussed in any further detail than what is given in the plant layout description. This is because they are not relevant to the objective of this research project.

### 3.2.1 TREATMENT PLANT LAYOUT

A layout of the treatment plant as at 2007 is provided in Figure 3.1 below.

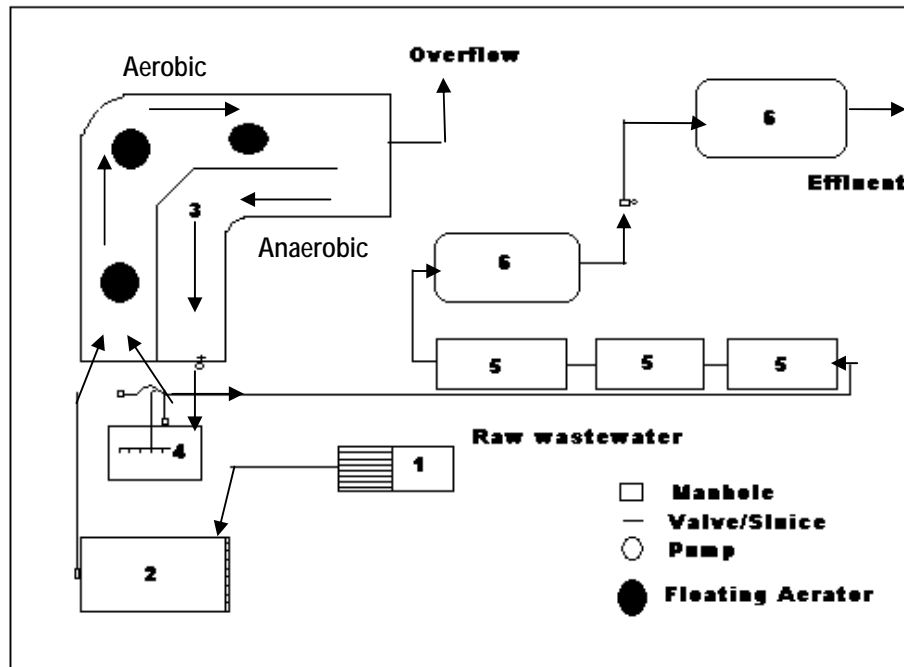

Figure 3.1: Schematic layout of the Citrusdal Wastewater Treatment Plant

Wastewater flows through the system as follows:

- 1) Raw wastewater goes through one manually raked bar screen at the inlet works.
- 2) Septic tank of 12 x 12 x 4.2 m with a total water capacity of 470m<sup>3</sup> acts as a primary settling tank and allows for anaerobic digestion of settled organics. The septic tank has an absolute maximum retention capacity of approximately 14 hours at 1 ML/d.
- 3) The septic tank effluent undergoes aerobic secondary treatment in the aerated lagoon. The total volume of the lagoon is 7 480 m<sup>3</sup>. It is divided into aerobic and anaerobic zones by a separation wall shown by the demarcating line in Figure 3.1. The wastewater flow direction in the lagoon is from the aerobic to the unaerated zones. The aerobic zone is equipped with three floating aerators; 7.5 kW aerator 20 m from the beginning of the lagoon, a 7.5 kW aerator 30 m downstream the first and a 5 kW one 20 m further downstream. The second half of the lagoon is neither aerated nor mixed to allow for sedimentation of the suspended solids. The lagoon has a retention time of approximately 9.4 days at 1 ML/d.
- 4) The lagoon effluent is pumped from the end of the unaerated zone to the nitrifying trickling filter (NTF) for tertiary treatment (nitrification). The NTF has a cross flow plastic media with a cross section of 5.5 x 5.5 m and an approximate height of 5.4m. The plastic media has a specific surface area of 142 m<sup>2</sup>/m<sup>3</sup> giving a total media surface ( $A_{ms}$ ) area of 23 100 m<sup>2</sup>. Some of the

NTF effluent is returned to the aerated lagoon and the rest goes to the maturation pond / reed beds for final treatment.

- 5) The three reed beds are operated in series have a total surface area of 3 389 m<sup>2</sup>.
- 6) The effluent from the reed beds goes through two retention dams with surface areas of 480m<sup>2</sup> and 500 m<sup>2</sup> respectively before it is discharged into the Olifants River. Some of the effluent is used to water the surrounding golf course during the summer period.

### 3.2.2 LAGOON OPERATION

Theoretically, the lagoon is a suspension mixed lagoon because the power density is approximately 2.6 W/m<sup>3</sup> (Marias and Ekama, 2000). However, the entire lagoon is not aerated. According to Muller *et al.*, 2004 unpublished, with the position of the aerators as illustrated in Figure 3.1, approximately 45% of the total volume of the lagoon is aerated. This correlates to an aerobic retention time of 4.2 days. With the present power capacity of 20 kW, only 26% of the lagoon volume is suspension mixed. Hence, in order to ensure that 45% of the aerated lagoon is suspension mixed, more mixing energy would be required than the aeration energy (Muller *et al.*, 2004). Hence in practice, the lagoon operates as a facultative aerated lagoon. Facultative aerated lagoons are characterised by insufficient oxygen to meet the biological oxygen demand to keep the solids in suspension. In this case, there is also insufficient mixing power to keep the solids in suspension in the aerobic section.

Due to the oxygen limitation and short aerobic retention time (~ 4 d at 1ML/d), no nitrification takes place in the aerated zone of the lagoon. While, theoretically it could take place during the summer season, ammonia oxidation was not observed. The presence of algae in oxidation ponds (lagoons) which was observed every summer in the lagoon could also ascribe to the lack of ammonia oxidation (Stone *et al.*, 1975).

The lagoon effluent quality necessary for efficient external nitrification should have a low TSS concentration of approximately <15 mgTSS/l (Lutz *et al.*, 1990) and a biodegradable soluble COD concentration below 27-30 mgCOD/l (Parker *et al.*, 1986). Technically, the unaerated zone should produce a relatively solids free effluent because there are no mechanical mixing to keep the solids in suspension in this zone and the soluble COD concentration should be low provided the lagoon is operation efficiently.

### 3.2.3 NITRIFYING TRICKLING FILTER

The NTF was an upgrade addition to the CWWTP. It is a single-stage operated trickling filter (with no recycle) and has been in operation for the past 10 to 15 years. The NTF is a tertiary treatment unit following the aerated lagoon. Lagoon effluent is pumped to the top of the NTF and distributed over the media through a sprinkler network. The top of the trickling filter is not covered allowing oxygen to be supplied to the NTF through natural convection through the media voids.

### 3.3 INITIAL FINDINGS

There was very little reliable data available before the start of the investigation in 2001. Thus it was difficult to ascertain the performance of the NTF at Citrusdal. Muller *et al.* (2004 unpublished) took preliminary grab samples to determine the performance of the NTF at the start of their investigation (Table 3.1).

#### COD

The influent soluble COD to the TF is approximately 68 mg COD/L. According to literature, for optimum nitrification conditions, the soluble *biodegradable* COD concentration in the NTF should be between 27 and 30 mgCOD/l (Parker *et al.*, 1986).

Table 3.1: Initial analysis of NTF (Muller *et al.*, 2004 unpublished)

Parameter	Units	Nitrifying Tower Influent (NTI)	Nitrifying Tower Effluent (NTE)
COD <sub>unfiltered</sub>	mgCOD/l	180	168
COD <sub>filtered</sub>	mgCOD/l	68	62
Floc filtered COD	mgCOD/l	54	50
TKN <sub>unfiltered</sub>	mgN/l	51.2	26.5
TKN <sub>filtered</sub>	mgN/l	40.0	19.3
FSA	mgN/l	35.6	13.2
Nitrite	mgN/l	0.3	0.9
Nitrate	mgN/l	0.7	24.1
Total Phosphate <sub>unfil</sub>	mgP/l	9.5	9.5
Total Phosphate <sub>fil</sub>	mgP/l	7.9	7.9
Alkalinity	mg/l as CaCO <sub>3</sub>	245	74
pH		8.22	7.81

\*All filtered samples are 0.45µm filtered

It was estimated that only 16 mgCOD/l of the soluble COD influent concentration was biodegradable. Thus the influent soluble biodegradable COD was well within the acceptable range that ensures that limits heterotrophic and nitrifier competition for oxygen. The floc filtered COD concentrations of the influent and effluent NTF samples are similar. Muller *et al.* (2004 unpublished) inferred from this that most of the soluble COD content is unbiodegradable.

The influent particulate COD concentration was 112 mgCOD/l. This high value is a result of the organisms and algae that do not settle out in the lagoon (Muller *et al.*, 2004 unpublished). The effluent particulate COD concentration is 106 mg COD/L. It is evident that most of these solids go through the tower unchanged and can thus be assumed to be unbiodegradable since the literature on NTFs indicate there is little suspended solids (nitrifier biomass) generated by the NTFs themselves. It was also

concluded that the particulate COD does not clog the media since an insignificant amount (0.05% of the influent) is removed or stays behind in the NTF.

#### Ammonia

The low lagoon effluent (NTF influent) nitrate concentration of 0.7 mgN/l confirmed that very little nitrification takes place in the lagoon. Total nitrogen (ammonia+nitrite+nitrate) concentrations in the influent and effluent indicated that no denitrification took place in the trickling filter.

#### pH

The nitrifiers responsible for the removal of ammonia are pH sensitive. They grow optimally in a pH range of 7.0 to 8.5 with sharp declines in growth rates outside these limits. The NTF at Citrusdal is operating within the optimum pH range (Table 3.1).

Muller *et al.*, 2004 noted the following regarding the operation of the NTF as at 2001:

- The layout of the NTF does not allow for flooding to control flies, worms and snails.
- There is no provision for recycling of TF effluent to increase the HLR.
- Based on the influent and effluent samples, there was little evidence of predator organisms such as snails, worms and flies.
- The COD concentrations and pH range do not appear to hinder nitrification rates.
- The trickling filter relied on natural convection for aeration. It was suspected that the poor nitrification performance was due to insufficient air flow (oxygen supply) through the tower.

### 3.4 INITIAL RECOMMENDATIONS FROM THE 2001 INVESTIGATION

The low nitrification rates at the start of the investigation in 2001 could not be accounted for by the pH and COD concentrations. Thus they postulated the following suggestions with the aim of improving nitrification rates to 1.0 gN/m<sup>2</sup>d:

#### a) Aerated lagoon

Aerators to be repositioned in the lagoon as illustrated in Figure 3.1. The aerators should also be immersed to their maximum water depth to improve their aeration and mixing capacity.

#### b) Nitrifying trickling filter

The following recommended alterations were suggested on the NTF;

- i) Supply the trickling filter with forced ventilation fans
- ii) Installation of an effluent recycle system
- iii) Installation of sampling ports along the depth of the TF wall. This will allow the progress of nitrification with depth to be investigated.

- iv) Flow measurement devices on the treatment plant particularly around the NTF. This will allow for mass flow representation of the data.

## 3.5 IMPLEMENTATION OF RECOMMENDATIONS

Over a period of two years, the above recommendations were implemented at the Citrusdal WWTP. The cost of some of these modifications was borne by the Municipality and some by the research project.

### 3.5.1 AERATED LAGOON

The aerators were positioned as illustrated in Figure 3.1 (page 3-2) and were immersed to their maximum water depth. Concrete slabs were placed under the aerators to prevent scouring of the clay lagoon floor. The purpose of this was to improve the COD removal capacity of the lagoon and consequently reduce the COD concentration fed to the NTF to as low as possible. It was not possible to determine the improvement in the COD removal capacity that repositioning the lagoon aerators had because the data collected before the start of the investigation in 2001 was sporadic and unreliable.

### 3.5.2 NITRIFYING TRICKING FILTER

Forced ventilation fans and depth sampling port were installed. An approximate illustration of the position of these modifications on a typical face of the NTF is provided in Figure 3.2.

#### 3.5.2.1 Forced ventilation

Four XPELAIR 320 W, 50 Hz forced-air blower fans have been installed one on each face. There is no media in the first meter of the NTF depth from the ground. The fans were placed immediately below the bottom of the media offset from the centre (Figure 3.2). The fans force air through the NTF from the bottom of the media through to the atmosphere. The ventilation was checked with smoke. It was found that the smoke drawn in at the fans exited the NTF at the top around the outside becoming progressively less towards the centre.

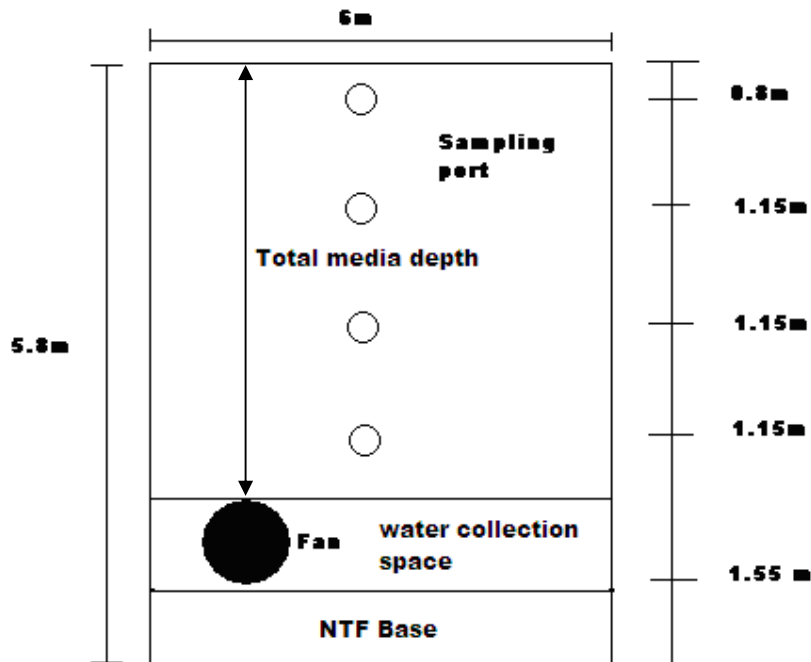

Figure 3.2: Typical NTF side wall as at 2007

### 3.5.2.2 Sampling ports

The nitrifying tower was fitted with cored sampling ports of 80mm diameter, spaced as shown in Figure 3.2. The ports are cored 2 m into each of the NTF faces, North, South, East and West respectively, through the brick wall and into the media. Slotted PVC pipes were inserted into the cores to prevent the media from collapsing whilst allowing for water to flow through the slotted pipes. A sampling device was manufactured to extract samples from the slotted pipes in the cored holes.

### 3.5.2.3 Flow distribution

The lagoon effluent is pumped to the top of the tower and distributed through a network of sprinklers. The influent pipe to the top of the NTF line is situated in the West face of the NTF. The flow distribution at the top of the tower is such that the pressure of the wastewater through the sprinklers decreases from the West face towards the East face because of energy losses in the system (see Figure 3.3 on the next page). It is thus expected that the flow rate on the East face should be the poorest of all faces because of the wastewater distribution network design.

The pressure and flow rate through the sprinklers also decreases along on each transverse distribution line. This was verified by measuring the flow through each of the sprinklers with a bucket and stopwatch.

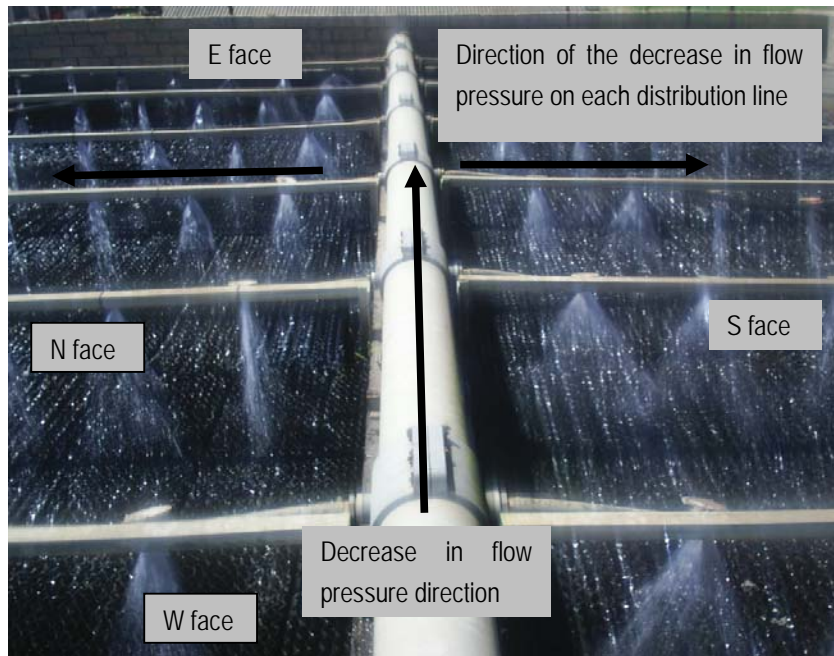

Figure 3.3: Influent flow distribution network of the NTF

#### 3.5.2.4 Recycle of effluent

In order to increase the hydraulic loading on the TF, a TF effluent recirculation system was designed and installed in October 2005. The effluent recirculation system was designed to provide an additional flow of 93 m<sup>3</sup>/hr. This is approximately 2.5 times influent flow rate to the NTF (of 40 m<sup>3</sup>/hr). The purpose of the 3 pumps and high flow rate was to allow for flexibility in choosing an effluent recirculation ratio that would result in maximum nitrification rates.

#### 3.5.2.5 Flow measurement devices

No accurate and reliable flow measurement devices had been installed on the recirculation system by 2005. An orifice plate was installed on the recirculation line, but its headloss needed to be too high to get meaningful readings which reduced the flow too much. There is a flowmeter that measures the influent flow from the lagoon to the influent of the NTF. However, this flowmeter has not been regularly calibrated. Thus it was necessary to verify the readings obtained from this flowmeter.

### 3.6 PRELIMINARY RESULTS OF THE PERIOD BETWEEN 2001 -2005

The purpose of these preliminary results is to illustrate the ammonia removal efficiency of the NTF before the writer's contribution to the project commenced. The removal efficiency of the NTF at

Citrusdal was only 13% at the start of the research investigation in 2001. The removal efficiency improved to approximately 39% after the installation of forced ventilation fans.

Owing to the remote location of the NTF and the limited manpower in the research group, there was not enough data collected during 2005 to confidently comment on the performance of the NTF. However the scattered results obtained have been included as an approximate indication of the performance of the NTF. From the data in Table 3.2, during July ApANRs of 1.55 gN/m<sup>2</sup>d were achieved on the two occasions when the samples were collected. The rainy winter season at Citrusdal extends from May to August which results in increased HLRs on the NTF and consequently better media wetting. This could explain the high ApANR and the ammonia mass removal of 20 kgN/d achieved in this rainy month.

**Table 3.2: Initial apparent nitrification removal efficiency (Adapted from Mofokeng thesis 2006)**

Date	NTF Influent (mgN/l)	NTF effluent (mgN/l)	Mass of ammonia removed (kgN/d) <sup>4</sup>	ALR <sup>3</sup> (gN/m <sup>2</sup> d)	ApANR <sup>3</sup> (gN/m <sup>2</sup> d)	Nitrification removal (%)
<sup>1</sup> Ave 7/99-7/01	44.2	38.4	5.6	1.83	0.24	13
<sup>1,2</sup> Ave 10/02-07/03	37.3	22.1	14.6	1.55	0.63	42
01/07/05	56	38	17.3	2.32	0.75	32
28/07/05	53	32	20.1	2.20	0.87	40
15/09/05	54	46	7.7	2.24	0.33	15
05/10/05	55	36	18.2	2.28	0.79	35
<b>AVE 2005</b>	<b>55</b>	<b>38</b>	<b>15.8</b>	<b>2.26</b>	<b>0.69</b>	<b>31</b>

<sup>1</sup>These values are obtained from Muller *et al.*, 2004 unpublished

<sup>2</sup> Fans installed during 2001

<sup>3</sup> Apparent nitrification rates [gN/(m<sup>2</sup> media surface. day) for 23 100 m<sup>2</sup>]

<sup>4</sup> Mass of ammonia removed is calculated based in the 40 m<sup>3</sup>/hr (~ 1ML) treatment capacity of the Citrusdal WWTP

It appears that the NTF experienced relatively high ALRs with an average effluent ammonia concentration of **38 mgN/l** in 2005. This is significantly higher than the required final WWTP effluent ammonia concentration limit of **< 3mgN/l**. Nonetheless, it can be deduced from the results in Table 3.2 that the NTF operation was not ammonia-limited. The installation of fans improved the nitrification efficiency, but not sufficiently to achieve low effluent ammonia concentrations. Therefore, the low ApANR must be as a consequence of other operating or biochemical variables. The sample data collected after the installation of the effluent recirculation is limited and unreliable and thus the influence of the increased hydraulic loading rate on the performance of the NTF could not be determined by the end of 2005.

### 3.6.1 INTERNAL PERFORMANCE

The internal performance of the NTF was determined by collecting samples along the trickling filter depth via the sampling cores. These samples were collected before the installation of the effluent recirculation system. A significant presence of filter flies was found in most of the samples withdrawn and in some sampling ports no sample could be collected due to poor media wetting.

The total HLR without recirculation on the system was 2.0 m/hr which is 33% less than the required minimum of 3 m/hr. Hence it was anticipated that there would be patchy biofilm growth and predator proliferation, particularly filter flies, in the NTF.

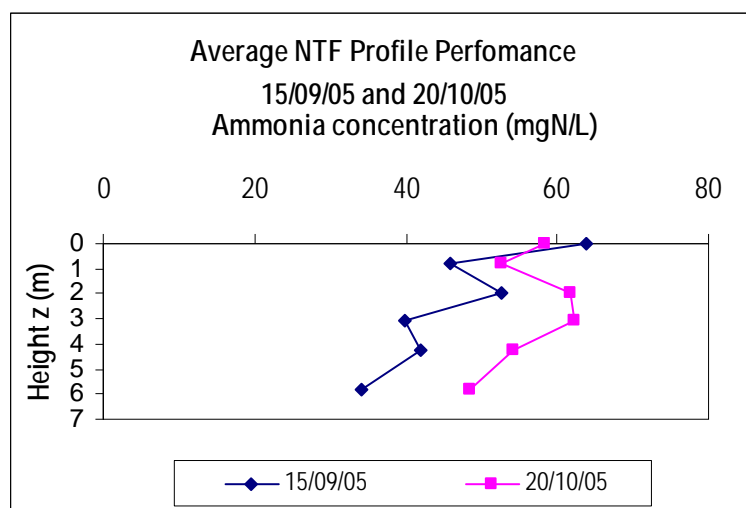

Figure 3.4: Average\* NTF Profile Performance before the installation of NTF effluent recycle (\*Average of ammonia concentrations taken from all the 4 NTF faces at the same depth)

Figure 3.4 illustrates a strong depth dependence of the removal capacity of the biofilm with depth which confirms that the biofilm growth is not homogenous with depth of NTF. From the literature reviewed, this would be expected in a single stage operated NTF. The steep gradient of the curves is an indication that little ammonia is removed as a function of depth. The irregularities in this 'almost' linear relationship of ammonia concentration vs. depth could be as a result of irregular biofilm growth in the TF.

It appears from these preliminary results that the low HLR could be the main cause for the low nitrification rates. Low HLRs result in poor and irregular media wetting and patchy biofilm growth as a result of filter fly proliferation which feeds on the biofilm. The HLR was therefore increased by introducing an effluent recycle to the system. This is expected to reduce the poorly wetted/dry patches which are conducive to the development of filter fly larvae. The consequence of this should be an improvement in nitrification rates and a more linear internal ammonia concentration as a function of depth profile.

### 3.7 FINAL RECOMMENDATIONS

The following recommendations were made at the end of 2005 to improve the nitrification performance of the NTF;

- i) Frequent sampling to confidently assess and draw conclusions on the performance of the NTF.
- ii) An accurate flow measurement method was required for the effluent recycle system.
- iii) The flowmeter that measured the influent flow to the NTF needs to be calibrated.
- iv) The effluent recirculation pump filters and the sprinklers needed to be cleaned regularly. Due to the high algal content in the open water surfaces (lagoon and effluent sump), the sprinklers and pump filters get clogged frequently.
- v) The effluent recycle system needed to be maintained to ensure its optimum operation. Hence a designated plant operator at CWWTP needs to be assigned for this specific task.

## CHAPTER 3: PRELIMINARY FULL-SCALE NITRIFYING TRICKLING FILTER PERFORMANCE

3.1	INTRODUCTION	3-1
3.2	BACKGROUND TO THE OPERATION OF THE CITRUSDAL WASTEWATER TREATMENT PLANT (CWWTP)	3-1
3.2.1	Treatment plant layout	3-2
3.2.2	Lagoon operation	3-3
3.2.3	Nitrifying trickling filter	3-3
3.3	INITIAL FINDINGS	3-4
3.4	INITIAL RECOMMENDATIONS FROM THE 2001 INVESTIGATION	3-5
3.5	IMPLEMENTATION OF RECOMMENDATIONS	3-6
3.5.1	Aerated lagoon	3-6
3.5.2	Nitrifying trickling filter	3-6
3.5.2.1	Forced ventilation	3-6
3.5.2.2	Sampling ports	3-7
3.5.2.3	Flow distribution	3-7
3.5.2.4	Recycle of effluent	3-8
3.5.2.5	Flow measurement devices	3-8
3.6	PRELIMINARY RESULTS OF THE PERIOD BETWEEN 2001 -2005	3-8
3.6.1	Internal performance	3-10
3.7	FINAL RECOMMENDATIONS	3-11

Figure 3.1: Schematic layout of the Citrusdal Wastewater Treatment Plant	2
Table 3.1: Initial analysis of NTF (Muller <i>et al.</i> , 2004 unpublished)	4
Figure 3.2: Typical NTF side wall as at 2007	7
Figure 3.3: Influent flow distribution network of the NTF	8
Table 3.2: Initial apparent nitrification removal efficiency (Adapted from Mofokeng thesis 2006)	9
Figure 3.4: Average* NTF Profile Performance before the installation of NTF effluent recycle (*Average of ammonia concentrations taken from all the 4 NTF faces at the same depth)	10

## CHAPTER 4

### METHOD OF INVESTIGATION

#### 4.1 INTRODUCTION

This chapter gives a description of the sampling methods and analysis of the data that was captured at full-scale and laboratory scale investigations. It is divided into two main parts; the first part discusses the methods of investigation that were employed at the NTF at full-scale while the second part discusses the laboratory scale experimental design and set up.

#### 4.2 FULL-SCALE INVESTIGATION

Due to the limitations mentioned in Chapter 1, the number of site visits to Citrusdal was limited. At the start of the project in February 2006, it was decided that site visits would be carried out on a monthly basis in order to monitor the performance of the NTF and to collect samples. A detailed account of the observations recorded on the operation of the treatment plant and due samples collected during each site visit can be found in Appendix B.

The operation of the NTF was subject to numerous operational upsets during the first six months of the investigation in 2006. Optimum operating conditions were interrupted by numerous pump and power failures and fans that were out of order, which generally took several weeks to repair. The once per month sampling frequency was found to be inadequate to determine the effect of the operational interruptions on the performance of the TF. Hence, it was decided to collect samples during the month in order to obtain a more representative data set. Upon discussions with management at the treatment plant, a staff member was assigned to the maintenance and operation of the NTF and to also assist in collecting samples.

In order to improve the communication between the investigators and the NTF operator at the CWWTP, a log sheet was generated which had to be faxed to the investigators on a weekly basis. This sheet required the operator to log the influent raw wastewater and NTF flowmeter readings and to also note any interruptions to the operation of the treatment plant units particularly the NTF. An example of a compiled log sheet is given in Appendix B.

### 4.2.1 SAMPLE COLLECTION

The objective of the investigation was to determine the performance of the NTF, thus samples were mainly collected from points surrounding the trickling filter. Hence, no samples were collected from the aerated lagoon zone or the final effluent pond. Samples were collected from the following sampling points:

- i) Raw wastewater influent  
A grab sample was taken after the manually raked screen bars
- ii) Nitrifying trickling filter influent  
A grab sample was taken from the same influent sprinkler at the top of the NTF each time.
- iii) Effluent nitrifying trickling filter  
A grab sample was taken from the NTF effluent sump.

The samples collected at these points were used to quantify the nitrifying performance of the trickling filter. In order to increase the monthly data sets, the operator at the CWWTP was required to also collect samples from the above sampling points three times a week. However, due to staff shortages experienced by the CWWTP management, the designated NTF operator was not always available to collect samples as frequently as it was required. This resulted in some months having a smaller and less representative data set than others.

#### 4.2.1.1 Sample preservation

Initially, the NTF operator collected one unfiltered composite sample in a 180 ml sample bottle at each of the previously mentioned sampling points. These composite samples were made up of grab samples that were collected 3 times a day between the working hours of 07H30 and 16H30. Each sample was preserved with mercuric chloride (1 drop of 9.26 g/l) at the time that it is collected. At the end of the working day, the samples were mixed and a composite sample was taken from the mixture and refrigerated at 10°C. With site visits taking place monthly, this meant that a sample would be analysed after a maximum of three weeks. It was decided that a composite sample is a better representation of the 'average' performance of the NTF on a typical day rather than a sample that was collected once during the day. A sample collected once a day would not be a reasonable measure of the performance of the NTF on typical day due to the varying diurnal influent ammonia load at full-scale treatment plants. A sample from the lagoon effluent zone (nearby the abstraction point of the NTF feed pump) was also included as a check on the influent samples collected by the operator. The analysis of the lagoon effluent and influent NTF samples should essentially yield the same results.

The samples collected by the NTF operator at times differed significantly from those collected by the writer in the same month. This could have been because some biological activity was still taking place in the unfiltered samples after they had been preserved and refrigerated. It was therefore decided that two composite samples should be collected at each point, where; one sample is unfiltered and the other filtered using a 0.45µm filter paper using vacuum filtration. Both samples were still preserved with

mercuric chloride and kept in a freezer ( $< 0^{\circ}$ ) until collection. This should decrease the turbidity of the samples and reduce the likelihood of further biological activity taking place.

#### 4.2.2 PROFILE SAMPLE COLLECTION

In order to measure the instantaneous performance of the NTF and the progress of nitrification with NTF depth, profile samples were collected once a month during the site visits conducted by the writer. Due to lack of available people power, samples could not be simultaneously collect along all four faces the NTF. All profile sampling sessions started with the North face and continued to the East, South and ended with the West face. On each face, samples were collected starting with the sampling port at the top of the tower. It took about 60 minutes to sample all four faces. The samples were preserved immediately and filtered through a  $0.45 \mu\text{m}$  filter membrane using vacuum filtration on site.

Influent and effluent NTF samples were collected at the start and the end of the profile sampling session which took approximately one hour. The results of these two sets of data were found not to vary significantly, so it is assumed that in the time taken to collect samples along all four faces, the nitrifying performance of the trickling filter does not change much. However, simultaneous collection of profile samples on all faces would have been a more accurate measure of the instantaneous internal performance of the NTF.

#### 4.2.3 PROFILE SAMPLING

The time taken to collect a specified volume from each sampling port was recorded to give an indication of the flow of water passing through the media of the sampling port. This method was developed in order to quantitatively gauge the wetting rate, predator proliferation and turbidity of the samples collected along the media depth. This was coupled with microbial analysis of some of the samples, when feasible, to determine the internal behavior of the NTF. On average one sample on each face was analysed for microbial activity. These samples were either from sampling ports that exhibited good wetting rates or poor wetting rates. These samples were preserved immediately and tested after approximately 24 hour later in Cape Town. The lack of resources and expertise on site did not allow for the analysis to take place immediately after the samples had been collected.

##### 4.2.3.1 Method of evaluation

Profile samples were collected in a 180 ml sample bottle. A minimum HLR of 3 m/h ( $0.83 \text{ L/s}$  per  $\text{m}^2$  NTF cross-section area) (Boller and Gujer 1986b, Parker *et al.*, 1989) is required to eliminate the development of filter fly larvae. Theoretically, the HLR should be the same throughout the depth (and width) of the TF. Therefore, it should have taken only 2 seconds to collect approximately 170 ml of sample. However this doesn't take into account the effect that the cross flow media has in retarding the flow through the TF. Since the HLR at Citrusdal was lower than  $3.0 \text{ m/hr}$  it was decided to allow the

sampling device to be left in the sampling port for approximately 45 seconds. This time was found to be adequate to collect 180 ml of sample. The wetting rate was assessed as follows; it was regarded as good if the sample collected in 45 seconds was enough to fill the sample bottle (180 ml), average when half the sample bottle was filled and poor when the volume collected was less than half the sample bottle. In the event that the wetting rate was found to be poor, the sampling device was left in the sampling port until enough sample volume was collected for analysis purposes (approximately 50 ml). This method of assessment bears little indication of the actual hydraulic loading rate. Instead, it allows for observations to be made on the adequacy of the wastewater distribution through the NTF regardless of the operating HLR.

The turbidity of the sample refers to the solid content of the sample. The turbidity was regarded as low, medium or high and in some cases, the samples were relatively clear of suspended matter.

The predators of interest in plastic media NTFs are mainly worms and filter flies according to the findings in literature. The worms, in this case, were found to be of the life cycle of the filter fly. The presence of these biofilm predators was evaluated on a scale of 0 to 3, where 0 denotes no presence of predators, 1 - some presence and 3 - high predator presence.

#### 4.2.4 SAMPLE ANALYSIS

The following tests were performed on all the samples that were collected;

- i) COD, filtered and unfiltered
- ii) FSA, filtered
- iii) Nitrate and Nitrite, filtered

The profile samples were only analysed for FSA. Alkalinity tests were also conducted on the influent and effluent NTF samples in order to verify the results obtained from the FSA and Nitrates and Nitrites analyses.

All filtered samples are filtered through a 0.45µm filter membrane using vacuum filtration. These tests have been performed as per standard procedure in the Laboratory procedures - wastewater treatment laboratory at the University of Cape Town (Lakay *et al.*, 2002)

There is no differentiation between biodegradable and nonbiodegradable soluble COD in the reported values in this report because there was no available equipment to analyse for this during the research period. TSS analyses have not been done, instead; the solids have been reported as particulate COD (difference between the total COD and the total filtered COD).

### 4.2.5 FLOW MEASUREMENT

The CWWTP only has flowmeters on the raw influent wastewater stream and the influent to the NTF. Hence, it was necessary to devise a way of measuring the flowrate of the recirculation system on the NTF. Due to limited financial resources, it was not economical to install an in-line flowmeter on the recirculation system. Appendix C summarises the various flow measurement options that were considered. The bucket and stop watch method proved to be the most cost effective and gave relatively accurate results. This method entails recording the time it takes to capture 10 L of water from a sprinkler. A detailed account of the procedure and the results that were obtained can be found in appendix C.

### 4.3 DESIGN AND START-UP OF THE LABORATORY SCALE NTF

The laboratory provided a controlled environment under which the nitrifying performance of a NTF could be more accurately assessed given the limitations that were experienced at the full-scale investigation. The experimental set up illustrated in Figure 4.1 is not a scaled down model of the NTF at Citrusdal. The laboratory NTF was single stage and accommodated flooding in order to control predator proliferation. The reactor had a volume of 31 L, a diameter of 0.16 m and a total media length of 1.48m. The media was made up of spherical balls with a 25 mm diameter.

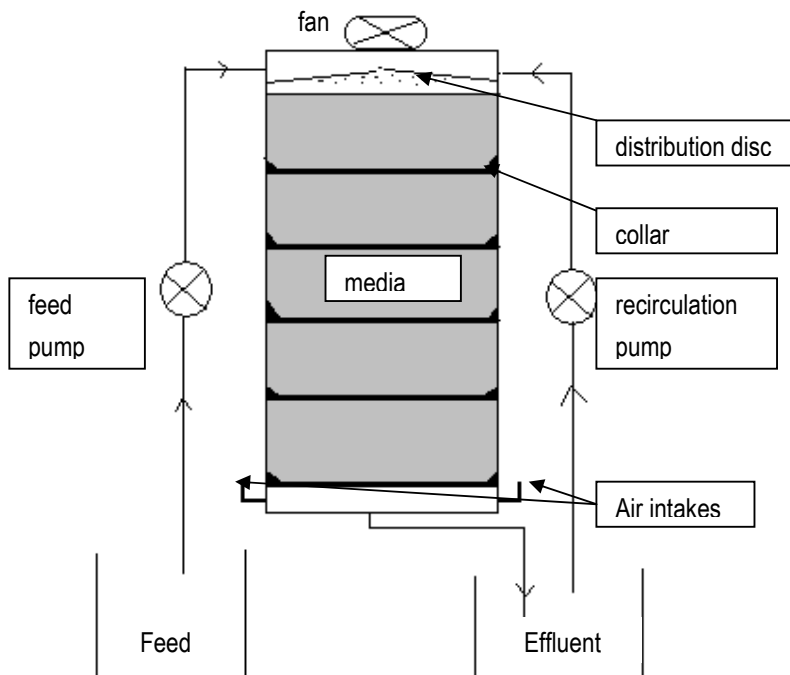

Figure 4.1: Schematic diagram of laboratory scale NTF set up

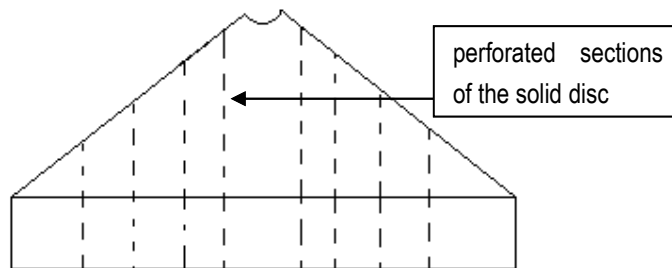

Figure 4.2: Cross section of the distribution disc

#### 4.3.1.1 Flow distribution

Due to the size of the reactor, there was a concern that with the low hydraulic loading rates the wastewater would not be adequately distributed over the media and would mainly flow along the reactor wall. In order to avoid this, the reactor was divided into four identical sections 0.37m long with a 1cm collar at the end of each section. The purpose of the collars was to channel the water flowing along the reactor wall back towards the middle of the reactor. At the bottom of each collar, there was a perforated disc redistributed the wastewater over the media in the subsequent reactor section. Provision was made for profile sampling on the collars of the reactor were the distribution discs were installed. However, due to the small diameter of the profile sampling ports and the low flowrates, it was not possible to collect any profile samples during the investigation period.

#### 4.3.1.2 Media density

The aim in the design of the laboratory scale NTF was to use a media specific density that was within the range of 150 to 200  $\text{m}^2/\text{m}^3$  (Boller and Gujer, 1985). An experiment was carried out to determine at which reactor diameter to media sphere ratio the media surface area to volume ratio remained constant. A summary of the experiment is given in Table 4.1. It was found that at a reactor diameter larger than 13.4 cm the media area to reactor volume ratio remained at a constant 145  $\text{m}^2/\text{m}^3$  for 25 mm spherical media. Hence, it was decided that the diameter of the NTF should be between 13.4 and 24.7 cm.

Table 4.1: Reactor density ratio experiment results

Reactor	Diameter cm	Total area $\text{cm}^2$	Vr L	density $\text{m}^2/\text{m}^3$
1	5.5	491	0.5	98
2	7.0	1100	1	110
3	8.8	2611	2	131
4	9.4	668	0.5	134
5	10.7	1394	1	139
6	13.4	2906	2	145
7	24.7	2906	2	145

Vr = volume of reactor

The reactor diameter selected was 0.16 m and yielded a media density ratio of 145 m<sup>2</sup>/m<sup>3</sup>. This correlates to approximately 566 balls per section of 0.37 m. However, the actual media density was found to be 109 m<sup>2</sup>/m<sup>3</sup> (only 425 balls per section of 0.37 m could be fitted in). The significant decrease in the ratio could be because of the space that the collars take up in the reactor and variation in ball diameter and shape imperfection leading to a less dense packing than theoretically calculated.

#### 4.3.1.3 Ventilation

The reactor was fitted with a 50/60 Hz axial electrical fan at the top of the NTF (see Figure 4.1). The air intakes on either side of the bottom of the reactor produce an upward motion of air through the reactor. The fan was operated continuously.

#### 4.3.1.4 Treated wastewater

Final effluent from the nitrifying denitrifying biological excess phosphorus removal (NDBEPR) UCT membrane system, which is operated at the UCT wastewater laboratory, was used as the feed to the reactor. The effluent had low ammonia concentrations, virtually zero suspended solids and average COD of 40 mgCOD/L. Hence the quality of this final effluent was of the recommended quality of secondary effluent suitable for external nitrification application - with in this case the requirement for an ammonia supplement.

#### 4.3.1.5 Ammonia dosing

The NTF treated 200L/d of wastewater effluent from the NDBEPR UCT membrane system, which was dosed with ammonia. Various volumes of a 135 g/L ammonium chloride concentration solution was fed to the system in order to obtain the desired influent ammonia concentration. The influent ammonia concentration has to be sufficiently high to prevent ammonia-limited conditions (when the NTF effluent ammonia concentrations are < 5 mgN/L).

#### 4.3.1.6 Alkalinity

At influent ammonia concentrations greater than 40 mgN/L the nitrification rates were at times pH limited. Hence, it was decided to increase the ammonia dosage within the range of 40-60 because the reactor showed potential to remove more than the initial estimated concentration of 25 mgN/L. Consequently, equation 2.3 (from the literature review chapter) by Boller and Gujer (1986b) was used to determine the required influent alkalinity that will result in non pH limited conditions. This was found to be 390 mg/l as CaCO<sub>3</sub> assuming a maximum ammonia concentration removal of 45 mgN/L (8.6 mg Alk/mg N, marginally higher than the stoichiometric 7.14). Accordingly, 22-30 g/d NaHCO<sub>3</sub> was added to the 200 l/d to ensure non pH limiting conditions. Erring on the side of caution, it was decided to dose the influent feed with 30 g NaHCO<sub>3</sub>.

#### 4.3.1.7 Temperature

The experiment was operated at a constant temperature of 20 °C, which is the standard laboratory temperature. The NTF was wrapped in black plastic to prevent light from penetrating to the media in order to limit algal growth in the reactor.

#### 4.3.1.8 Laboratory scale NTF start-up

The laboratory experiment was commenced in October 2006. The media surface was coated with a biofilm by recirculating activated sludge for two weeks. This biofilm coating assists attachment of the nitrifiers. Initially the experiment was operated with one entry point for the influent and recirculation flows i.e. recirculation and influent pipes fed into a common pipe which discharged the wastewater over the media. This resulted in low ApANRs which could have been ascribed to poor even media wetting, therefore resulting in dry patches on the media. When the performance of the NTF had not improved by the end of 2006, the set-up was reconfigured as illustrated in Figure 4.2 in February 2007.

### 4.3.2 SAMPLE ANALYSIS

Influent and effluent samples were collected daily and since the influent ammonia concentration was constant over a 24hr period, the time at which the samples were collected was not important. Upon collection, the samples were filtered immediately and refrigerated at 5°C until all analyses had been carried out.

The following tests were performed on all the samples that were collected;

- i) COD, filtered
- ii) FSA, filtered
- iii) Nitrates and Nitrites, filtered
- iv) Alkalinity, filtered

All filtered samples are filtered through 0.45µm filter membrane using vacuum filtration. These tests were performed as per standard procedure in the Laboratory procedures - wastewater treatment laboratory at the University of Cape Town. Due to the virtually zero effluent TSS concentration produced by the UCT membrane system, unfiltered COD tests on the influent were not carried out.

## CHAPTER 4: METHOD OF INVESTIGATION

4.1	INTRODUCTION	4-1
4.2	FULL-SCALE INVESTIGATION	4-1
4.2.1	Sample collection	4-2
4.2.1.1	Sample preservation	4-2
4.2.2	Profile sample collection	4-3
4.2.3	Profile sampling	4-3
4.2.3.1	Method of evaluation	4-3
4.2.4	Sample analysis	4-4
4.2.5	Flow measurement	4-5
4.3	DESIGN AND START-UP OF THE LABORATORY SCALE NTF	4-5
4.3.1.1	Flow distribution	4-6
4.3.1.2	Media density	4-6
4.3.1.3	Ventilation	4-7
4.3.1.4	Treated wastewater	4-7
4.3.1.5	Ammonia dosing	4-7
4.3.1.6	Alkalinity	4-7
4.3.1.7	Temperature	4-8
4.3.1.8	Laboratory scale NTF start-up	4-8
4.3.2	Sample analysis	4-8

Figure 4.1: Schematic diagram of laboratory scale NTF set up	5
Figure 4.2: Cross section of the distribution disc	6
Table 4.1: Reactor density ratio experiment results	6

University of Cape Town

## CHAPTER 5

# RESULTS AND DISCUSSIONS ON THE FULL-SCALE NITRIFYING TRICKLING FILTER PERFORMANCE

The full-scale investigation period of external nitrification on single stage operated NTF at Citrusdal WWTP took place between February 2006 to September 2007. The cross-flow plastic media of a specific surface area of  $142 \text{ m}^2/\text{m}^3$  has the following dimensions,  $5.5 \times 5.5$  by  $5.4$  m high. The trickling filter is a tertiary unit which treats secondary effluent from an aerated lagoon followed by a facultative lagoon to promote solids removal. The secondary effluent feed to the NTF is abstracted from the end of the facultative lagoon (Figure 4.1, Chapter 4).

The aim of the research investigation was to evaluate the effect of seasonal changes, hydraulic loading rates (HLRs), ammonia loading rates (ALRs) and influent soluble and particulate organic loading rates (OLRs) have on the full-scale nitrifying performance of the NTF and to explore whether apparent ammonia nitrification rates (ApANRs) of greater than  $1.0 \text{ gN}/\text{m}^2$  media surface/d or ammonia removal efficiencies greater than 80% could be achieved. Empirical actual ammonia nitrification rates (AcANR) were determined by taking profile samples along the TF media depth. The findings from the microbial analysis on some of the profile samples are described in an endeavor to explain the internal behaviour of the NTF and the nitrification results that were observed.

An overview of the performance of the NTF during this investigation period is initially discussed. Due to seasonal changes and disruptions to operating conditions, shorter periods were identified to highlight the effects of the aforementioned parameters on the (ApANR). The AcANR of the NTF is discussed under the selected operating periods and in addition, the ammonia concentration profiles of the individual TF faces are also discussed in detail to elucidate the internal behaviour of the Citrusdal NTF.

### 5.1 OVERVIEW OF THE NITRIFYING PERFORMANCE DURING THE INVESTIGATION PERIOD

The observed performance of the NTF during the winter and summer periods respectively is presented in this chapter taking into account the effect of soluble and particulate influent COD concentration trends and the hydraulic loading conditions on the apparent ammonia nitrification rate performance over the investigation period. The apparent ammonia nitrification rates (ApANRs) are based on the difference in the influent and effluent ammonia masses (Figure 2.2, Chapter 2). This rate does not take into account the internal effects or the inefficiencies of the TF media such as dry media patches due to poor media wetting resulting in non-uniform biofilm growth.

There was no reliable NTF wastewater temperature data routinely collected at the WWTP. However, the ambient air temperatures (obtained from the South African Weather Bureau) have been included in order to give an indication of the temperate differences of the summer and winter seasons at Citrusdal. The summer season extends from October to late April and is characterised by warm temperatures and low rainfall. The winter period, which extends from May to September, receives high rainfall and is characterised by lower temperatures. Table 5.1 summarises the average temperature and rainfall data recorded during the respective seasons of 2006 and 2007.

Table 5.1 Average ambient maximum and minimum air temperatures and rainfall data during the full-scale investigation period

	Maximum	Minimum	Total rainfall
Season	°C	°C	mm
Summer 2006	32.4	15.2	58.70
Summer 2007	33.0	15.9	78.70
Winter 2006	22.9	8.6	259.40
Winter 2007	22.4	8.3	361.95

During the investigation period of 728 days, the performance of the NTF did not reach steady state due to numerous disruptions to the desired optimum operating conditions. From the literature review, the optimal operating conditions are when the operating hydraulic loading rates (HLRs) were 3.0 m/hr or greater, continual supply of oxygen (all 4 fans in operation) and low influent soluble and particulate biodegradable COD concentration and virtually zero suspended solids concentration.

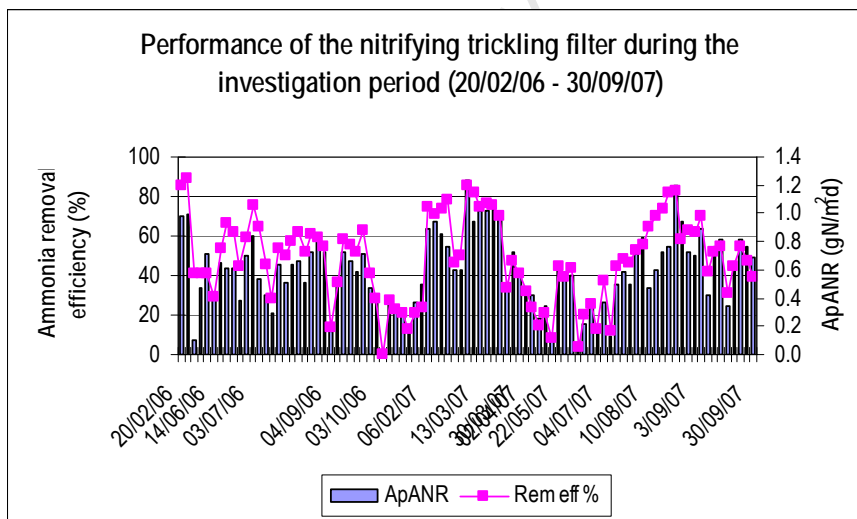

Figure 5.1: Apparent ammonia nitrification rate (ApANR) performance of the trickling filter during the investigation period (20/02/06 – 30/09/07)

The aim was to maintain optimal operating conditions for as long as possible in order to determine the maximum nitrifying capacity of the NTF at Citrusdal. However, frequent mechanical failures of pumps and fans, NTF operator negligence and factors beyond the control of the treatment plant management such as power failures resulted in disruptions to the performance of the NTF. Figure 5.1 illustrates the ApANRS during the investigation period. Maximum ApANRs of 0.84~1.00 gN/m<sup>2</sup>d (which is equivalent to removal efficiencies of 68-88%) were observed during the summer period of the research investigation. Such ApANRs were not achieved during the colder winter season. The reasons for the poor nitrifying performance discussed later on in the chapter.

The NTF operating conditions during the investigation period are summarised in Table 5.2 with the focus being on the highlighted ApANRs results for the summer and winter seasons respectively. The other parameters are the observed operating results associated with the respective average, maximum and minimum ApANRs values.

Table 5.2: Summary of the apparent ammonia nitrification rates of the NTF during the investigation period from February 2006 to September 2007

Parameter	Unit	SUMMER PERIODS				WINTER PERIODS			
		No. of samples	Ave	Max	Min	No. of samples	Ave	Max	Min
Qi	m <sup>3</sup> /hr		41	41	41		41	41	41
HLR <sup>b</sup>	m/hr	30	2.1	2.7	2.3	55	2.2	5.4	2.4
FSA <sub>i</sub>	mgN/l	30	30.4	35.0	33.8	55	30.2	33.9	26.7
FSA <sub>e</sub>	mgN/l	30	16.9	31.5	4.8	55	16.0	25.6	5.9
ALR	gN/m <sup>2</sup> d	30	1.25	1.50	1.45	55	1.21	1.45	1.15
<b>ApANR<sup>a</sup></b>	<b>gN/m<sup>2</sup>d</b>	<b>30</b>	<b>0.59</b>	<b>1.25</b>	<b>0.15</b>	<b>55</b>	<b>0.66</b>	<b>1.20</b>	<b>0.05</b>
SCOD <sub>i</sub>	mgCOD/l	30	81	68	67	55	74	102	39
SCOD <sub>e</sub>	mgCOD/l	30	81	90	61	55	62	59	41
PCOD <sub>i</sub>	mgCOD/l	30	144	123	112	55	123	154	124
PCOD <sub>e</sub>	mgCOD/l	30	147	145	39	55	116	152	96
OLR <sub>t</sub>	gCOD/m <sup>2</sup> d	30	9.27	16.25	4.88	55	8.25	20.49	4.26

NOTE: The maximum and minimum refer only the ApANRs (highlighted)

<sup>a</sup> apparent ammonia nitrification rate; <sup>b</sup> includes effluent recirculation flow

Abbreviation: OLR<sub>t</sub> = total organic loading rate (sum of the particulate and soluble organic loading rates)

The average HLR on the system was 2.1 and 2.2 m/hr for the summer and winter periods respectively. However, 60% and 100% of the data collected during the summer and winter periods of 2006 was at HLR below 1.4-1.5 m/hr. Hence, the performance of the NTF during 2006 was predominantly under sub-optimum hydraulic loading conditions. This explains the lower average ApANRs observed during the summer period 0.59 gN/m<sup>2</sup>d compared to the winter period 0.66 gN/m<sup>2</sup>d. The nitrifying performance of the NTF was expected to improve during the summer because of increased biological kinetic rates due to warmer wastewater temperatures – but the NTF was operating under inadequate hydraulic loading rates (HLRs), which are reflected in the low observed average ApANRs. The rainy winter

season results in improved media wetting and that may explain the higher average ApANRs achieved during the winter period (Table 5.2). The average total organic loading rate (OLR<sub>T</sub>) which is the sum of the soluble and particulate organic loading rates is 11% higher during the summer compared with winter. This is due to the prolific algal growth in the lagoon during the summer.

### 5.1.1 OVERVIEW OF THE INFLUENT ORGANIC LOADING ON THE NITRIFYING TRICKLING FILTER

During the summer period, the average influent soluble COD concentration remained unchanged through the NTF (Table 5.2) hence implying that on average the TF did not remove soluble COD. The average soluble OLR for the summer and winter periods were virtually the same at 3.32 and 3.12 gCOD/m<sup>2</sup>d respectively. Approximately 35% of the total OLRs throughout the investigation period was soluble. Figures 5.2a to 5.2d display the observed influent and effluent COD concentrations to the TF and the associated soluble COD removal rates during the summer and winter periods of the investigation (from 2006 to 2007). The graph shows irregular increases in removal rates. In cases where the effluent concentration was higher than the influent concentration, the removal rate has been accepted as zero.

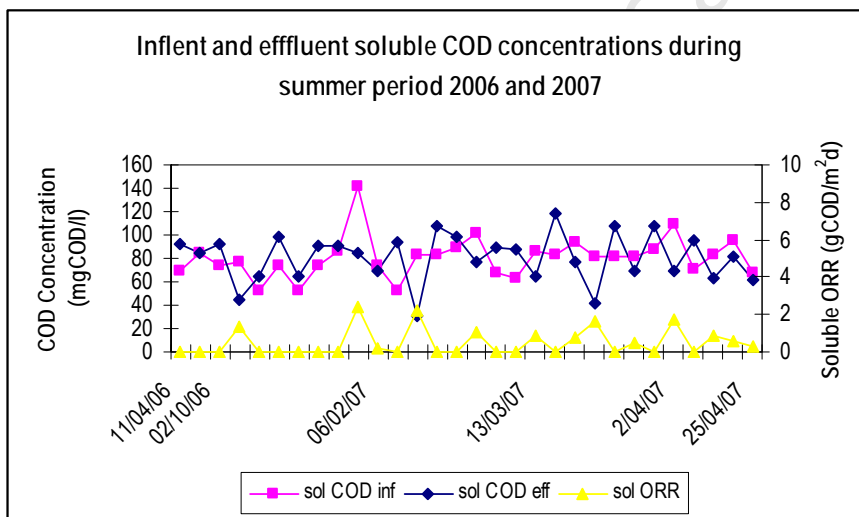

Figure 5.2a: Influent and effluent soluble COD concentrations and associated organic removal rates during the summer period 2006 and 2007

The average soluble organic removal rate (SORR) was found to be 0.52 gCOD/m<sup>2</sup>d. This is in contradiction with the average of the influent and effluent COD concentrations which were virtually the same, hence imply zero soluble ORRs. However this observed average includes the negative removal rates (when the influent COD concentration is less than the effluent) which have been accepted as zero.

Hence, the calculated average is not a true representation of the organics that are removed over time by the NTF. The graphs give a better depiction the organic removal trends of the NTF.

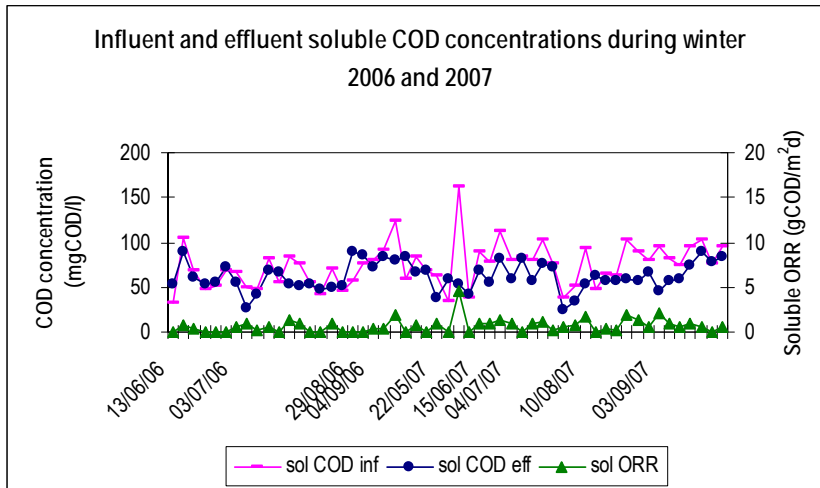

Figure 5.2b: Influent and effluent soluble COD concentrations and associated organic removal during the winter period 2006 and 2007

In comparing Figure 5.2a and 5.2b, it was found that the SORR trend increased during the winter. This is in agreement with the average 14 mgCOD/l difference between the influent and effluent COD concentrations (Table 5.2). This is due to the poorer organics removal capacity of the lagoon as a result of lower wastewater temperatures which decrease kinetic biological reaction rates. Therefore continued organics removal in the NTF was anticipated during the colder winter period.

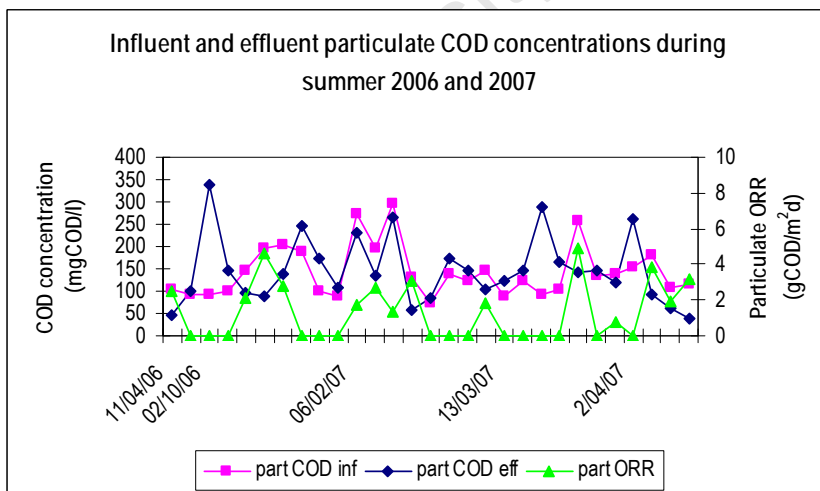

Figure 5.2c: Influent and effluent soluble COD concentrations and associated organic removal during the summer period 2006 and 2007

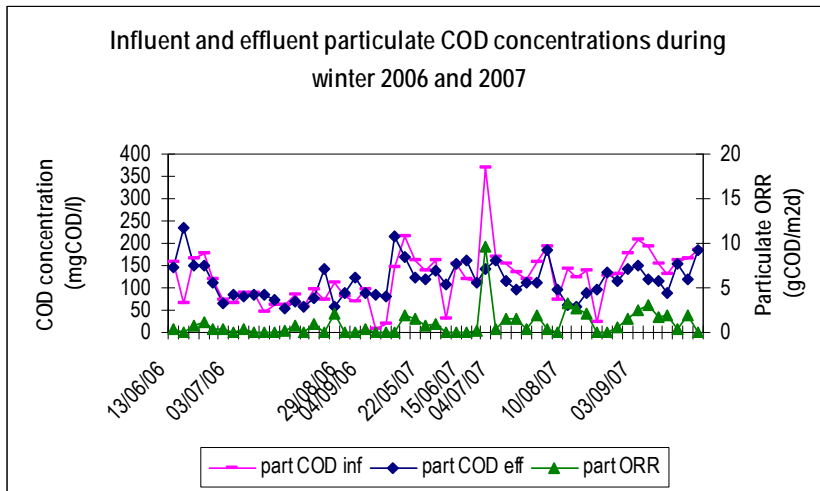

Figure 5.2d: Influent and effluent particulate COD concentrations and associated organic removal during the winter period 2006 and 2007

According to the influent and effluent particulate COD concentration results in Table 5.2 there should be a zero average particulate organic removal rate (PORR) observed during the summer period and minimal removal rates observed during the winter period. In Figure 5.2c, approximately 52% of the particulate ORR data shows a zero removal rate. Similarly, with the trends observed during the summer period, there are random increased PORR trends observed, which make up 48% of the data. The PORRs in Figure 5.2d corroborate the average influent and effluent particulate COD results for the winter period in Table 5.2.

### 5.1.2 EFFECT OF INCREASED HYDRAULIC LOADING ON THE NITRIFYING PERFORMANCE

The NTF effluent recirculation system to increase the HLR has been discussed in Chapter 3 and explained in more detail in Appendix D.

Table 5.3 summarises the operation periods of the recirculation system during the investigation period. The Badu Hydrostar (BHS) 35 1.5 kW pumps (standard large swimming pool pumps) were not robust enough for their intended purpose. The pumps were often out of order due to overheating and operator negligence in maintaining the system. In June 2007, these pumps were replaced with a single, more robust EBARA 1.1 kW pump. The EBARA pump remained in operation until the end of the investigation period in September with no mechanical or wear and tear failures taking place. This single pump had sufficient capacity to provide the same output as three of the BHS 1.5 kW pumps.

Table 5.3: Trickling filter recirculation pumps inventory during the investigation period of the research

Period	Number of days	Pumps in operation	Total HLR (including recirculation) m/hr	Recirculation percentage	Comment
10/10/05-20/02/06	133	2	2.1	30%	one pump on standby
20/02/06-06/03/06	17	0	1.4	0	Power cuts
16/03/06-14/06/06	104	2	1.6	20%	one pump on standby
01/07/06-26/07/06	25	1	1.4	5%	Two pumps out of order
26/07/06-24/08/06	29	2	1.6	20%	one pump out of order
24/08/06-24/11/06	61	1	1.4	5%	Two pumps out of order
24/11/06-11/04/07	140	3	2.3	70%	all 3 pumps in operation
11/04/07-22/05/07	41	3	2.4	80%	Changed type of sprinklers
22/05/07-30/05/07	8	2	2.6	90%	Effect of new Sprinklers
30/05/07-19/06/07	20	1	2.3	73-78%	Two pumps out of order
20/06/07-2/10/07	61	1	2.5	88%	New pump EBARA

The distribution system was found to be sensitive to the type of nozzle sprinkler used. The recirculation improved by 20% when all the recirculation sprinklers were replaced with nozzle sprinklers less sensitive to the presence of suspended solids (like filter flies) in the wastewater. Hydraulic loading rates of greater than 2.3 m/hr were attained from November 2006 until the end of the investigation period in September 2007. These hydraulic loading conditions prevailed for approximately 335 days of the investigation period (46% of the investigation period). For most of the investigation period, the HLRs were < 1.4 m/hr. Figure 5.3 illustrates the ApANRs under the varying hydraulic loading conditions during the investigation period.

The low HLRs conditions during 2006 were due to the inefficient initial design of the TF effluent recycle system and a spate of pump failures. Consequently, the design of the recirculation system was revised to increase its throughput during November 2006. The maximum output of the TF effluent recirculation system was 2.8 m/hr, which is less than the minimum literature requirement value of 3.0 m/hr.

Figure 5.3 illustrates a significant increase in ApANRs when the HLR was increased from 1.4 m/hr to approximately 2.3 m/hr. The ApANR increased from approximately 0.46 to 0.85 gN/m<sup>2</sup>d, this is a 49% increase due to a 41% increase in the HLRs. However, ApANRs started to decline during March 2007 in spite of the increased HLRs. It was conceded that the poor performance of the NTF from March to the end of July 2007 (Figure 5.3) was due to factors other than inadequate HLRs. The possible reasons for the poor performance of the NTF during this period are discussed later in this chapter.

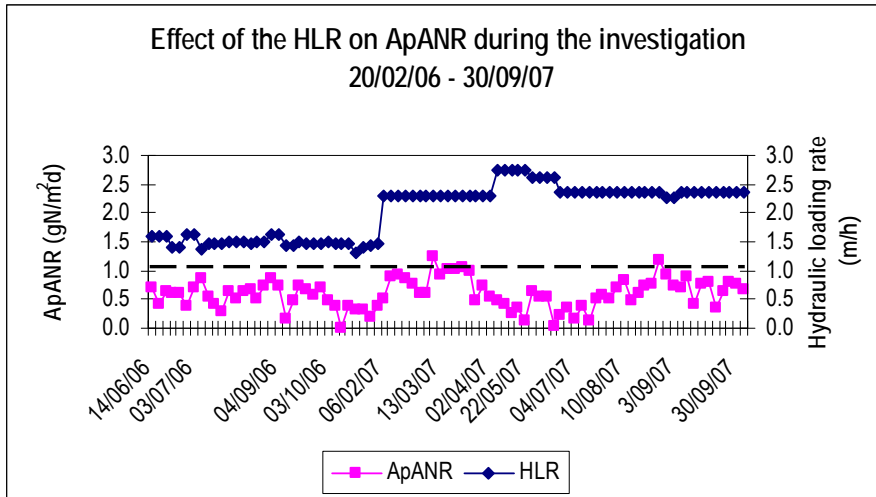

Figure 5.3: Effect of the hydraulic loading rate (HLR) on the apparent ammonia nitrifying performance of the trickling filter (20/02/06 – 30/09/07)

### 5.1.3 OVERVIEW OF THE INTERNAL AMMONIA PROFILE OF THE NITRIFYING TRICKLING FILTER

Profile samples were collected (the method of profile samples collection has been discussed in Chapter 4) from the four sampling ports of the individual TF faces in order to determine the internal performance of the NTF. Figure 5.4 shows a diagram of the East and South face of the TF at Citrusdal. The individual internal performances of the West, East, North and South faces of the TF are discussed in detail in subsequent sections of this chapter. This section describes the overall average internal performance of the NTF during the summer and winter periods respectively. An average profile sample is essentially, an average of the ammonia concentrations measured at the same depth at all four TF faces (e.g. the average ammonia concentration of the NTF from the first profile media depth =  $[N_a(\text{West } 1) + N_a(\text{East } 1) + N_a(\text{North } 1) + N_a(\text{South } 1)]/4$  where 1 refers to the first profile sampling port on the media depth and  $N_a$  refers to the ammonia concentration).

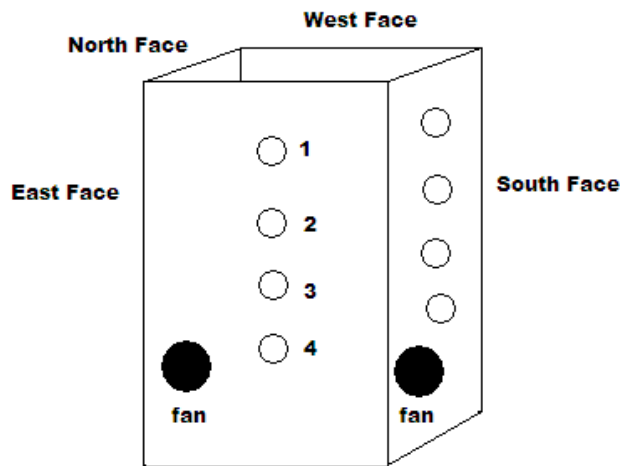

Figure 5.4: Diagram of the East and South faces of the Citrusdal trickling filter

The profile of ammonia concentration with depth for a single-stage plastic media NTF operating optimally is expected to be a uniform linear relationship (Boller and Gujer, 1986a). This linear relationship is indicative of internal biofilm activity that is homogeneously declining with media depth due to ammonia-limited conditions in the lower regions of the TF media depth. These ammonia-limited conditions lead to patchy (reduced) biofilm growth which leads to the expected linear decreasing relationship.

Figure 5.5 illustrates the internal behavior of the NTF during the summer period. The profile samples during 2005 were collected prior to the installation of NTF effluent recycle system. It is likely that the ammonia concentration profiles with depth displayed in Figure 5.5 for 2005 (15/09/05 and 20/10/05) may be due to the predomination of the TF by filter fly larvae because of the then low operating HLRs of 1.4 m/hr. The maximum and minimum ammonia concentration removed during the summers period was 23.4 mgN/l (14/03/07) and 9.8 mgN/l (10/04/07) respectively. An almost linear relationship of ammonia concentration with depth is demonstrated for 16/02/07, 07/02/07 and 14/03/07 with operating HLRs of greater than 2.0 m/hr. However, microbial analyses of these profiles were not conducted to confirm the biofilm activity implied by the almost linear relationship of ammonia concentration with depth depicted in Figure 5.5. The effect that the operation of two out of four fans has on the internal performance of the NTF is evident from the significant change in ammonia profile from March to April 2007. The ApANRs for these two months were 0.96 (14/03/07) and 0.42 (11/04/07) gN/m<sup>2</sup>d.

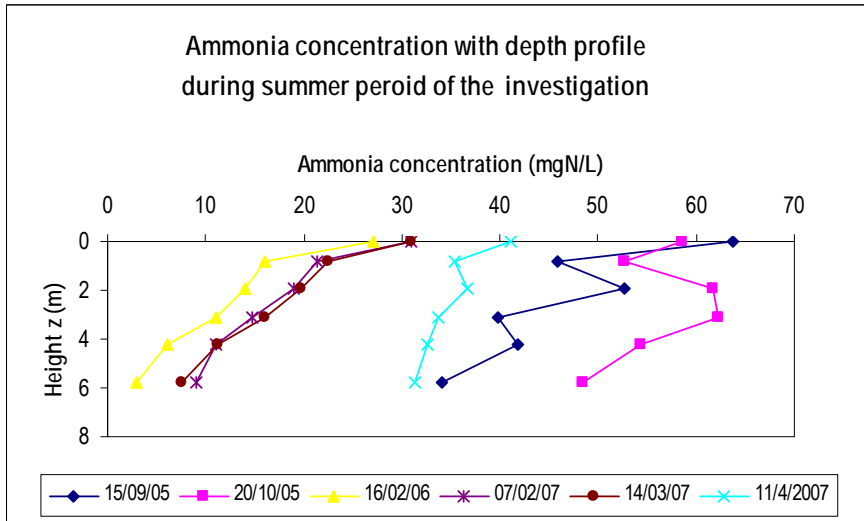

Figure 5.5: Average internal ammonia concentration profile of the nitrifying trickling filter during the investigation summer period

The April (11/4/2007) ammonia concentration profile is the steepest, which is an indication of low ammonia concentration removals. Table 5.4 lists the operating parameters of the NTF when only 2 out of the 4 fans were in operation for a period of three months (after 14 March to May 2007).

Table 5.4: Apparent ammonia nitrification rate of the NTF with 2 of the 4 forced air ventilation fans in operation

	*Temperature Maximum	Temperature Minimum	Total rainfall	HLR	ALR	ApANR <sup>1</sup>
2007	°C	°C	mm	m/hr	gN/m <sup>2</sup> d	gN/m <sup>2</sup> d
March	33.5	15.8	15.70	2.3	1.41	0.83
April	29.8	13.1	45.00	2.6	1.68	0.45
May	25.8	10.3	63.55	2.7	1.33	0.37

\* The reported temperatures are ambient and not of the wastewater temperatures

<sup>1</sup>Apparent ammonia nitrification rates for the respective months

It is evident that the ApANRs are negatively affected by the decrease in ambient temperature and concomitantly presumed to mean a decrease in wastewater temperatures when two fans are in operation. The ambient temperatures have been used because there was no wastewater temperature data. It is speculated that under colder wastewater temperatures the transfer of oxygen to the biofilm is limited especially when the NTF has less than optimum oxygen supply. There was a 56% decrease in ApANR with a 3.7 and 2.7 °C drop in maximum and minimum ambient temperatures respectively and 2 out of 4 fans in operation. This illustrates the sensitivity of the NTF performance to inadequate dissolved oxygen supply via media ventilation.

The internal ammonia profile of the Citrusdal NTF was found to be irregular and non-linear during the winter period (Figure 5.6). There was limited data on the profile performance of the TF during the 2006 winter period. The erratic ammonia concentration profile observed during May 2006 could be mainly due to insufficient media wetting conditions which led to dry and patchy biofilm areas making the NTF susceptible to fly larvae infestation and biofilm foraging. This conclusion was confirmed from microbiological observations – the NTF profile samples were dominated by filter fly remains, algae and *Nematodae* during the winter of period 2007 and it is likely that the same applied for the internal NTF operation during the 2006 winter period.

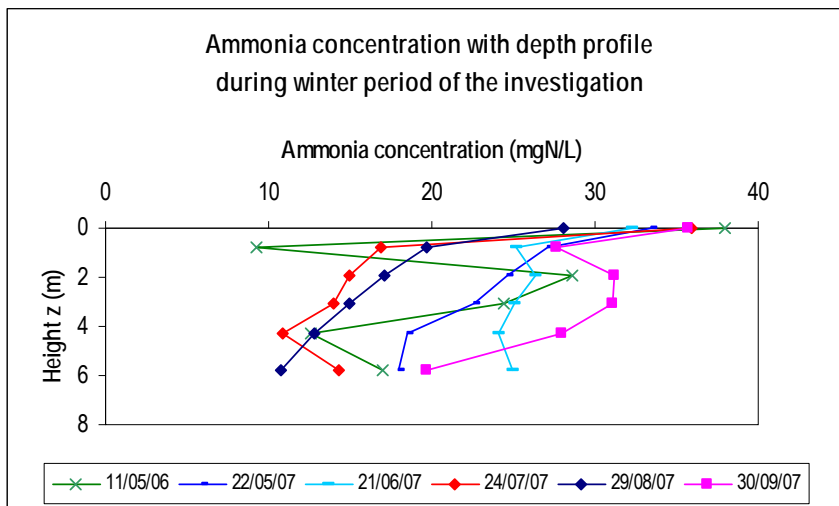

Figure 5.6: Average internal ammonia concentration profile of the nitrifying trickling filter during the investigation winter period

In Figure 5.6, the maximum and minimum ammonia concentrations removed (influent - effluent) were 21.5 mgN/l (0.89 gN/m<sup>2</sup>d) (24/07/07) and 7.4 mgN/l (0.31 gN/m<sup>2</sup>d) (21/06/07) respectively from the data collected over the winter periods of the investigation. The profile samples for 24/07/07 were collected on a day that was preceded by heavy rainfall and there was intermittent rainfall on the day of the profile samples collection. The rainfall received over the two days could have diluted the wastewater flowing through the NTF (but not the influent z=0) and hence falsely indicated prolific biological activity. This is corroborated by the microbial analysis of the July profile samples that showed signs of low nitrifying biofilm activity in any of the profile samples. The TF was infested with *Nematodae*, a limited presence of *Rotifers* and there was significant evidence of fly debris. Moreover, if there was prolific biofilm activity that is associated with such high ammonia removals, the profile for July should have been similar to the profiles of 16/02/06, 07/02/07 and 14/03/07 in Figure 5.6. These profiles are associated with ammonia concentration removals of greater than 22.0 mgN/l and show large ammonia concentration differences between the different depths – the July 07 has a large difference between the influent (z=0) and the first depth (z=0.8m) but within the media the differences in ammonia concentration between the levels is small. Therefore the relatively high ApANRs of 0.89 gN/m<sup>2</sup>d is a false impression of prolific biofilm activity.

## 5.2 INTERNAL BEHAVIOUR OF THE NITRIFYING TRICKLING FILTER

The qualitative analysis method, which has been described in Chapter 4, was used to determine internal predator presence and internal wastewater distribution over the NTF media under the different hydraulic loading conditions. In order to substantiate the qualitative analysis observations and ApANRs, the profile samples were analysed for microbial activity from May until September 2007. This section discusses the findings from the qualitative and microbial analyses of the NTF profile samples in an endeavor to substantiate the observed internal performance of that was discussed in the previous section. Figure 5.7 is a sketch of the position of the profile sampling ports on a typical face of the NTF at Citrusdal.

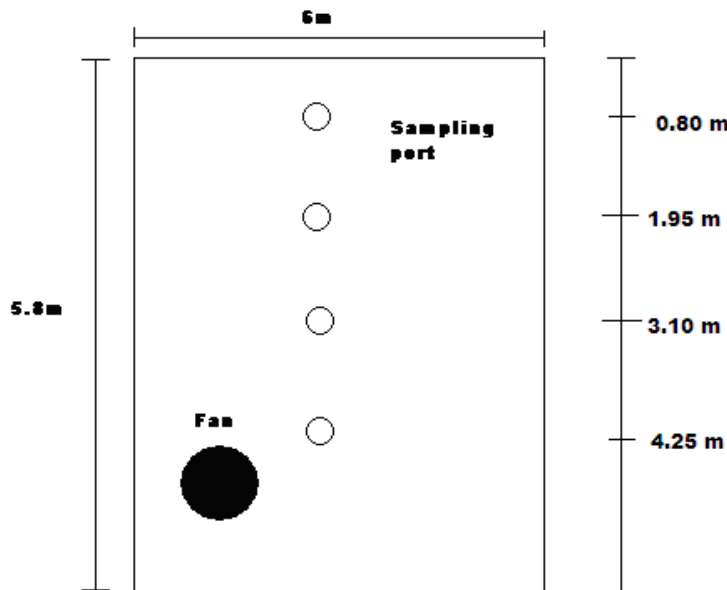

Figure 5.7: Profile sample positions along the NTF media depth

### 5.2.1 MEDIA WETTING

The structural design of the wastewater distribution system over the NTF media may lead to dry media patches that the wastewater cannot infiltrate. In Figure 5.8, the depth of the concrete beam (upon which the influent feed pipe rests) extends into the media and it is not clear how far into the media the beam extension is. It spans from the West to the East face with the profile sampling ports of the respective faces located directly beneath it. The first sampling ports, which are 0.8 m from the top of the TF media, exhibited poor media wetting. It could be that the beam across the TF casts a dry shadow, which would explain the poor media wetting displayed only from the first sampling ports on the East and West faces respectively. Moreover, the pressure of the water decreases from the West to the East face (Figure 5.8)

due to the flow distribution design. Because of this, the East face continuously exhibited the poorest media wetting during the investigation period even under increased HLRs.

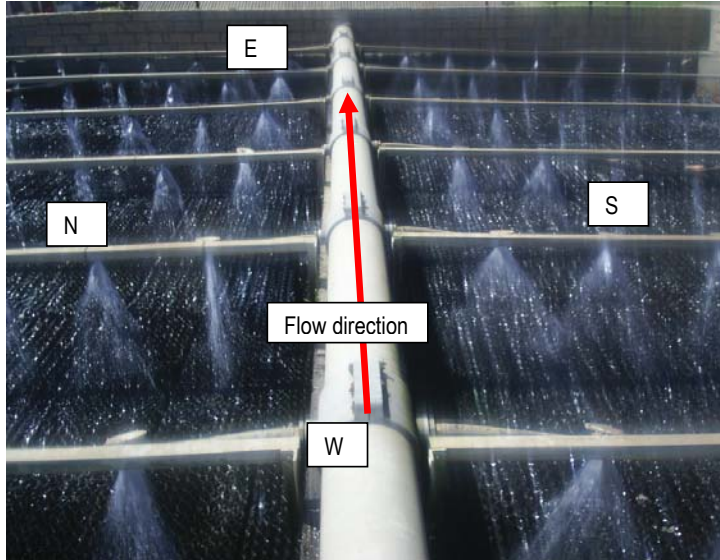

Figure 5.8: Influent flow distribution network of the NTF

A summary of the qualitative analysis regarding predator presence and media wetting can be found in Appendix G. Figures 5.9 and 10 give a diagrammatic summary of the media wetting profile during the investigation period. The media wetting was graded as follows; G = good, A = average and P = poor.

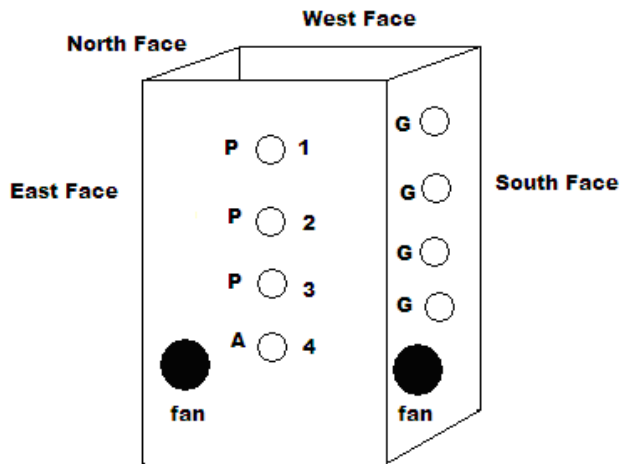

Figure 5.9: A summary of the media wetting through East and South faces

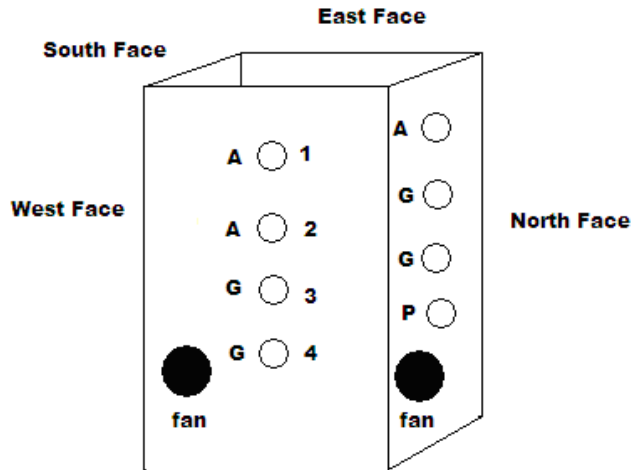

Figure 5.10: A summary of the wetting rate through West and North faces

The media wetting profile for the West face was good, as was expected, because the first couple of sprinkler rows have the highest water pressure and therefore delivers the highest wastewater throughput of all the sprinkles - moving in the easterly direction (Figure 5.8). The media wetting on the East face profile was observed to be poor especially for the first two sampling ports down. It could be that the media is clogged with particulates, which may retard or inhibit the hydraulic pathway of the wastewater over the upper media section of the TF. In addition, the water pressure through the sprinklers along the eastern face is lower than the rest of the TF faces. The last (bottom) sampling port displayed good media wetting presumably due to less particulates clogging the bottom region of the TF. The North face media wetting profile was good on average, especially over the media between the second and third sampling ports. The bottom North face sampling port exhibited poor media wetting which is contrary to the flow through the last sampling ports of all the other profile TF faces (Figures 5.9 and 5.10). The South face displayed good media wetting throughout the investigation period.

Using the qualitative method it was found that across all the profiles of the NTF faces, the observed media wetting did not improve with increased HLR conditions. This method of analysis for media wetting is therefore insensitive to changes in hydraulic loading rate; this is because it was not based on the minimum hydraulic loading rate of 3 m/hr. Nevertheless, the method does give an indication of which parts of the media are not adequately wetted regardless of the total HLR which was its intended purpose.

## 5.2.2 MICROBIAL ANALYSIS OF THE PROFILE SAMPLES

The profile samples collected during the winter period of 2007 (May to September) were analysed for biological activity in an endeavor to gauge whether there was nitrifying biomass activity. The TF profile samples exhibited varying degrees of turbidity i.e. the degree of suspended particles in the collected

wastewater profile sample. The suspended solids in most cases were found to be of true floc and/or fly remains or debris. There was no equipment available during the research period to analyse for the presence of nitrifying biomass in the floc. True floc provides a filamentous network upon which bacteria can attach onto in order to feed. Although the presence of true floc may be a positive sign, in the samples analysed in this investigation, it does not necessarily lead to the conclusion of nitrifying biomass being present. Depending on the level of degradation of organic (COD) and inorganic (ammonia) substrates, certain higher order protozoans may be present. At this NTF site, the following protozoan was found: *Protista*, *Rotifer* and *Paramecium*. The presence of *Protistae* and *Rotifers* indicate complete biodegradation of substrates because they feed off the endogenous residue of the bacteria responsible for the biological degradation. The presence of *Paramecium*, which is a ciliate, is indicative of the intermediate stages of the biological substrate degradation processes. The presence of these protozoans was regarded as a positive sign for ammonia substrate degradation as they indicate varying stages of biofilm activity. Primitive segmented worms (*Nematodae*) were also observed in some of the profile samples. These worms are usually found in raw sewage that has been partially treated and their presence is not seen as positive sign for the possibility of nitrifying biomass activity.

There was significant algae present in the profile samples, even though the profile samples were collected during the winter period. Motile algae, *Phacus*, are able to grow in the TF by moving towards the light. The TF wall structure is a single face brick, which was pervious hence the excessive leaking (Figure 5.11) that was observed. Hence light can penetrate the TF through the cracks of the wall making it conducive for *Phacus* growth on the TF media – especially on the areas where the TF is exposed to direct sunlight for the longest period over a 24-hour period (mainly on the East and North faces of the TF).



Figure 5.11: Leaking on the North face during the investigation period

The effect that the presence of algae has on nitrifying biomass growth could not be ascertained during the investigation period. However, Stone *et al.* (1975) found the presence of algae to have a negative effect on ApANRs during their investigation on externally nitrifying unfiltered secondary effluent from an oxidation pond.

### 5.2.3 PREDATOR PROLIFERATION

The NTF was subjected to a continual presence of filter flies (*Physcoda*) and worms (*Nematodae*) throughout the investigation period. The presence of these predators varied depending on the HLR. The qualitative analysis of the predator proliferation is an observation of the prevalence of fully developed filter flies, snails and worms, from the collected profile samples. There were no snails observed at this site.

Prior to the increase in HLRs by introducing a NTF effluent recycle stream, the West, East and South faces had a high prevalence of developed filter flies despite the good media wetting observed from the South profile. The South and East faces were most affected in the event of low HLRs due to pump failures as they exhibited the most prevalence of filter flies. For HLRs > 2.0 m/hr, a minimal presence of filter flies was observed. Also, the prevalence of worms decrease for HLRs > 2.0 m/hr with an exception of the East face which displayed the highest prevalence throughout the research period. This verifies the observations of the East face which exhibited the poorest wetting rate (Figure 5.9) thus resulting in dry media patches which are conducive the development of filter fly larvae the first state of the life cycle of a filter fly.

It was speculated from the microbial analysis of the profile samples that during periods of warmer wastewater temperatures and low HLRs, the NTF is dominated by the filter fly, *Physcoda*. The fly larvae graze on both the biofilm bacteria and particulate matter in order to obtain energy for metabolic and reproductive processes, which is in agreement with the findings from Parker *et al.* (1989) on predator proliferation in NTFs. During periods of increased HLRs and colder wastewater temperatures, filter fly numbers were observed to decrease. Microbial analysis of the profile samples needs to be carried out on a year round basis in order to verify the speculations made on the internal bacterial activity of the NTF during the summer.

## 5.3 PERFORMANCE OF THE NTF DURING SELECTED OPERATING PERIODS

Due to the seasonal changes and disruptions to operating conditions, shorter periods which highlight good and poor NTF performances have been selected. Period I refers to the performance of the TF during the summer period while Period II refers to the winter period performance.

### 5.3.1 PERFORMANCE OF THE NITRIFYING TRICKLING FILTER DURING PERIOD I-A

Period I-A is the summer periods from October 2005 to end of February 2006 and November 2006 to end of March 2007. It is characterised by good hydraulic loading conditions (HLRs greater than 2 m/hr), full function of at least three of the four fans and high influent particulate COD concentrations due to prolific algal growth that takes place in the facultative aerated lagoon due to warm temperatures and sunlight. Table 5.5 summarises the operating parameter during Period I-A. Samples were only collected during February 2006 for the summer period of 2005/2006, which is insufficient to adequately assess the performance of the NTF during this period. Nonetheless, it has been assumed that it is possible that the NTF exhibited these good nitrification rates from November 2005 as a consequence of the TF effluent recirculation system which was installed mid-October. The average maximum ApANR observed during the investigation was 1.00 gN/m<sup>2</sup>d (February 2006), which is equivalent to a total ammonia mass removal of 23.1 kgN/d. These optimum removal rates were obtained under ammonia-limited conditions with three of the four fans in operation. ApANRs of 0.85 gN/m<sup>2</sup>d (mass removal of 19.6 kgN/d) were obtained under oxygen-limited conditions during the 2006/2007 summer period. This rate is approximately 15% lower than the one attained during February 2006.

Table 5.5: Operating parameters during Period I-A

Parameters	Summer	Nov 05-	Nov 06-			
	Units	Feb 06	Mar07			
No of data	°C	3	15			
Qi	m <sup>3</sup> /hr	40	41			
			Ave	SSD	Max	Min
Influent Ammonia	mgN/l	28.5	30.5	3.3	35.8	23.0
Effluent Ammonia	mgN/l	3.70	10.7	5.8	22.2	4.76
ALR	gN/m <sup>2</sup> d	1.15	1.32	0.15	1.54	0.99
HLR	m/hr	2.2*	2.3	0.0	2.3	2.3
ApANR <sup>a</sup>	gN/m <sup>2</sup> d	1.00	0.85	0.21	1.25	0.48
SCOD <sub>influent</sub>	mgCOD/l	65	80	19	141	50
SCOD <sub>effluent</sub>	mgCOD/l	65	80	20	118	31
PCOD <sub>influent</sub>	mgCOD/l	-	149	64	298	74
PCOD <sub>effluent</sub>	mgCOD/l	-	161	72	340	58

\*estimated value due to lack of reliable flowrate data during 2006

<sup>a</sup> apparent ammonia nitrification rate

The less than optimum ApANRs during the summer period of 2006/2007 could be due to inadequate ventilation because only 2 out of the 4 fans were in operation during March 2007.

The average internal performance of the NTF is depicted in Figure 5.12. The profile is a relatively linear function of ammonia concentration with depth, this is indicative of a homogenous biofilm development that linearly decreased with depth.

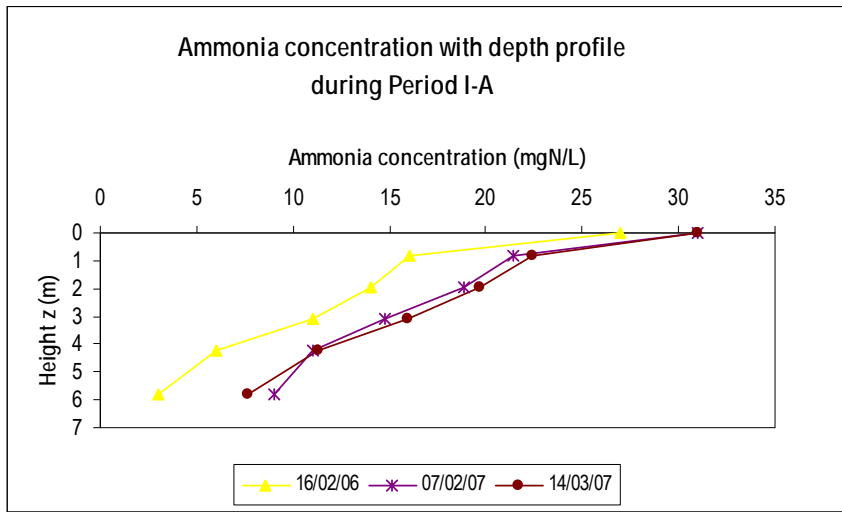

Figure 5.12: Average internal ammonia concentration profile of the nitrifying trickling filter during Period I-A

This profile is associated with single stage NTFs that are operating optimally. In addition, with the effluent ammonia concentration being greater than 5 mgN/l, the ApANRs were achieved under non ammonia limiting conditions. There was no microbial analysis of the summer profiles in Figure 5.7 thus the internal microbial activity could not be determined in order to substantiate the illustrated profiles.

### 5.3.1.1 Influent organic loading rate during Period I-A

The average soluble influent and effluent COD concentrations remained unchanged at an average of 80 mgCOD/l throughout this period, therefore no soluble COD removal took place. The effluent particulate concentration was observed to be 8% higher than the influent concentration (see Table 5.5). This was due to biofilm loss or the algae present in the TF effluent sump, which adds to the particulate organic content of the TF effluent samples. Figure 5.12 depicts the total organic loading rate (OLR<sub>t</sub>) and total organic removal rate (ORR<sub>t</sub>) trends during this period.

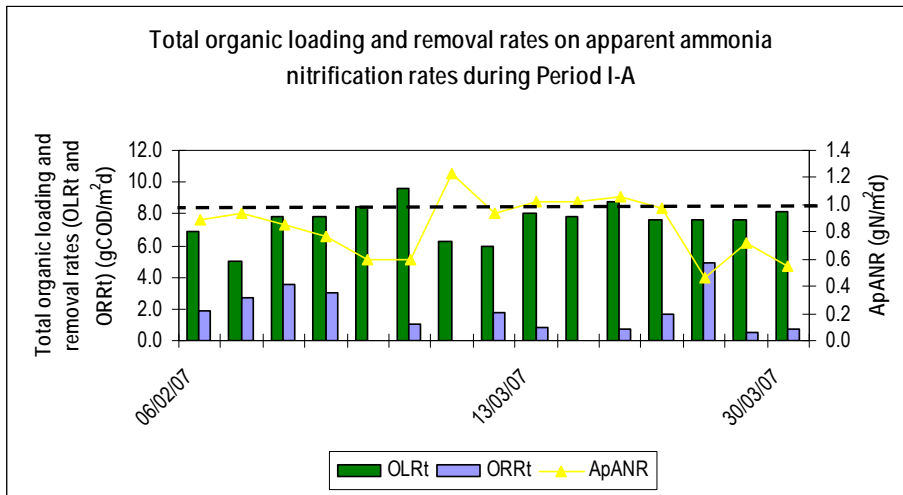

Figure 5.13: Total (includes soluble and particulate) organic loading and removal rates and apparent ammonia nitrification rates during Period I-A

ApANRs of  $\sim 1.0$  gN/m<sup>2</sup>d were achieved under minimal total ORRs as depicted in Figure 5.13. The decline in ApANRs towards the end of March was probably due to the inadequate ventilation (2 out of 4 fans in operation).

### 5.3.2 PERFORMANCE OF THE NITRIFYING TRICKLING FILTER DURING PERIOD II-A

During Period II-A (from August 2006 to end of October 2006) one of the three aerators in the oxidation pond was out of order, only 3 fans were in operation and there was a series of recirculation pump failures. There was aerator out order in the aerated lagoon. This was expected to reduce the COD removal potential of the aerated/facultative lagoon because decreased oxygen supply levels and lowered mixing power. Insufficient mixing power would result in less solids being kept in suspension to facilitate maximum surface area for COD removal by the suspend medium. The spate of pump failures resulted in hydraulic loading conditions that were less than 2.0 m/hr. Therefore, this period is expected to exhibit poor ApANRs due to inadequate wetting conditions and a possibility of increased influent biodegradable organics concentration. Table 5.6 summarises the operating parameters of Period II-A.

The average ApANR during this period was 0.59 gN/m<sup>2</sup>d, which corresponds to a removal efficiency of 41% and is equivalent to a mass removal of 13.6 kgN/d. This is approximately 41% less mass removed when compared to the maximum ApANR of 1.00 gN/m<sup>2</sup>d attained during Period 1-A. The effluent ammonia concentration throughout this period was  $> 5$  mgN/l; hence, the NTF operation was not ammonia-limited. Figure 5.14 confirms this, the ALR trend increases with a decrease in ApANRs thus the poor performance cannot be ascribed to insufficient influent ammonia concentration.

Table 5.6: Operating parameters during Period II-A

Parameters	Winter of 2006	Period II-A Aug-Oct 06			
	Units				
No of data		12			
Qi	m <sup>3</sup> /hr	40			
		<b>Ave</b>	<b>SSD</b>	<b>Max</b>	<b>Min</b>
Influent ammonia	mgN/l	31.5	8.3	49.6	26.9
Effluent ammonia	mgN/l	19.4	10.8	37.9	10.2
ALR	gN/m <sup>2</sup> d	1.45	0.08	1.6.4	1.31
ANR <sup>a</sup>	gN/m <sup>2</sup> d	0.59	0.34	1.32	0.17
HLR	m/hr	1.6*			
SCOD <sub>influent</sub>	mgCOD/l	75	20	124	52
SCOD <sub>effluent</sub>	mgCOD/l	77	16	99	44
PCOD <sub>influent</sub>	mgCOD/l	123	72	214	8
PCOD <sub>effluent</sub>	mgCOD/l	145	82	340	82

\*estimated HLR due to insufficient flowrate data during 2006

<sup>a</sup> apparent ammonia nitrification rate

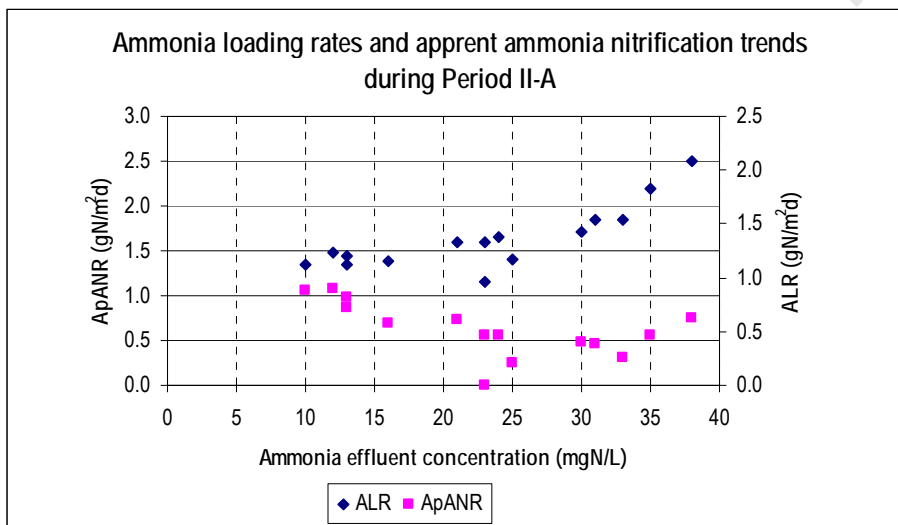

Figure 5.14: Effect of the ammonia loading rate on the ammonia nitrification rate of the trickling filter Period II-A

There were no profile samples collected during this period and hence no microbial analysis was carried out either; thus, the internal performance of the NTF could not be determined.

### 5.3.2.1 Influent organic loading rate during Period II-A

The influent and effluent soluble and particulate COD concentrations remained; on average, unchanged through the TF (see Table 5.6). The total OLR has decreased by 20% and the total ORR increased by 32% compared to Period I-A were the optimum ApANRs were observed. The PORR make up 79% of the total ORR of 1.90 gCOD/m<sup>2</sup>d. This corresponds to an apparent particulate COD removal

concentration of 36 mg COD/l. The soluble ORRs of 0.38 gN/m<sup>2</sup>d are lower than the 0.52 gCOD/m<sup>2</sup>d observed during Period I-A. Figure 5.15 illustrates the nitrifying performance of the NTF under the observed OLR and ORR trends of this period. The poor and irregular nitrifying performance of the NTF illustrated in Figure 5.15 cannot be solely ascribed to the organic loading and removal conditions. ApANRs declined significantly from September to December (Figure 5.15). This could be because of an increase in ambient temperatures, which increases the evaporation rates hence resulting in increased dry patches on the TF media, as the estimated operating HLR of 1.6 m/hr was insufficient for adequate media wetting. The poor nitrifying performance during this period could be due to filter flies colonising the NTF as a consequence of inadequate media wetting conditions coupled with the observed organic removal rates.

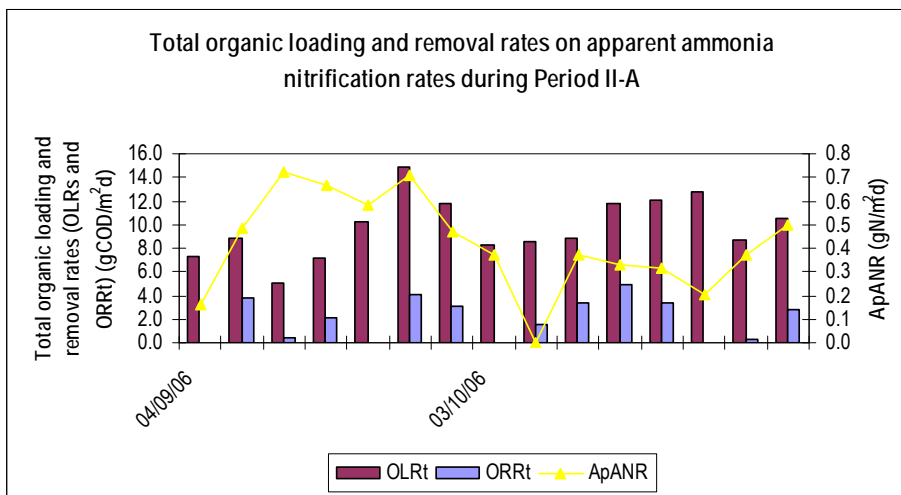

Figure 5.15: Total influent organic loading rates and organic removal rates and the apparent ammonia nitrification rates of the trickling filter during Period II-A

### 5.3.3 PERFORMANCE OF THE NITRIFYING TRICKLING FILTER DURING PERIOD II-B&C

Periods II B&C describe the performance of the NTF during the winter period under HLR > 2.0 m/hr. During Period II-B (from April 2007 to end of May 2007), two of the four fans were in operation and 108.55 mm of rainfall was recorded; Period II-C (from June 2007 to September 2007) all the fans were operating and 298.4 mm of rainfall was recorded. The operating parameters during these two periods are listed in Table 5.7. The effect that the lack of adequate ventilation has on apparent nitrification rates is evident by comparing the NTF performance during Period II-B (poor ventilation) and Period II-C (when maximum ventilation was restored with all four fans in operation). Apparent nitrification rates improved by 34% from 0.41 to 0.62 gN/m<sup>2</sup>d.

Table 5.7: Operating parameters during Periods II-B&amp;C

Parameters	Winter of 2007	Period II-B April-May 07				Period II- C Jun-Sept 07			
	Units								
No of data		9				24			
Qi	m <sup>3</sup> /hr	41				40			
		Ave	SSD	Max	Min	Ave	SSD	Max	Min
Influent ammonia	mgN/l	35.5	4.6	44.8	26.7	29.5	5.5	40.6	16.8
Effluent ammonia	mgN/l	26.1	6.3	34.6	17.4	15.1	5.7	26.9	4.14
ALR	gN/m <sup>2</sup> d	1.53	0.20	1.92	1.15	1.26	0.24	1.74	0.73
ApANR <sup>a</sup>	gN/m <sup>2</sup> d	0.41	0.15	0.64	0.05	0.62	0.26	1.20	0.13
HLR	m/hr	2.7	0.1	2.7	2.6	2.4	0.03	2.4	2.3
SCOD <sub>influent</sub>	mgCOD/l	81	42	162	35	82	17	112	39
SCOD <sub>effluent</sub>	mgCOD/l	63	19	96	39	65	15	90	24
PCOD <sub>influent</sub>	mgCOD/l	130	47	181	29	153	61	369	24
PCOD <sub>effluent</sub>	mgCOD/l	121	67	260	39	122	33	183	58

<sup>a</sup> apparent ammonia nitrification rate

The apparent nitrifying performance under varying ALRs experienced during Periods II B&C is illustrated in Figure 5.16 where the NTF operated under oxygen-limited conditions (effluent ammonia concentration > 5.0 mgN/l). The average ALR decreased from 1.53 gN/m<sup>2</sup>d during Period II-B to 1.26 gN/m<sup>2</sup>d during Period II-C. The decrease in ALRs could be due to the high rainfall received during the months of June and July of Period II-C. These two months received 60% (404.65mm) of the total rainfall that fell during this particular winter period. In addition to the high rainfall, the operating HLR for this winter period was between 2.7 and 2.4 m/hr, which may have resulted in dilute influent ammonia concentrations and hence decreased ALRs as illustrated in Figure 5.16.

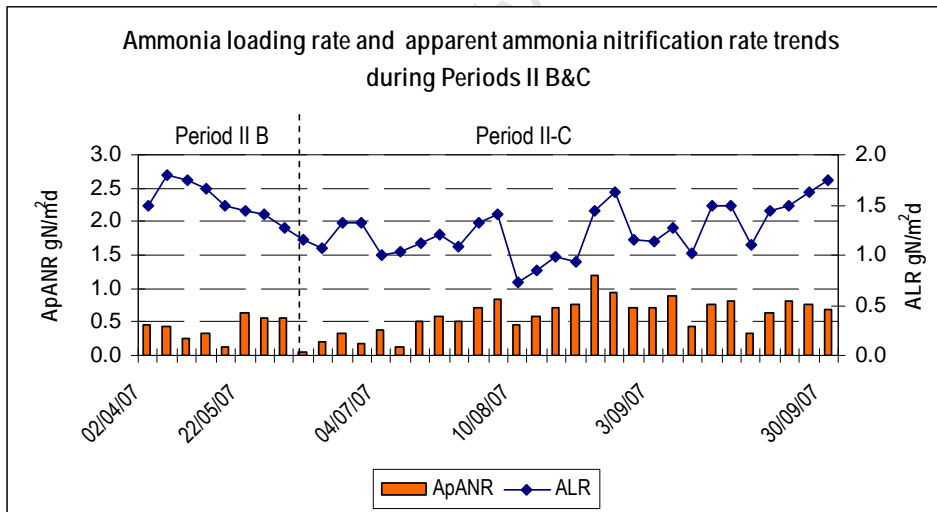

Figure 5.16: Effect of the ammonia loading rate on the apparent ammonia nitrifying performance of the trickling filter during Periods II B&C

The NTF's maximum ventilation capacity of all the four fans in operation was restored from June onwards; however, there was no of significant improvement in apparent nitrification rates. It could be that the lower wastewater temperatures and high rainfall coupled with high HLRs had a negative impact on the biofilm growth. The nitrifying performance of the TF showed signs of recovery towards the end of July but the removal rates did not stabilize. The average ApANR from August to September was 0.72 gN/m<sup>2</sup>d, which is 45% higher than the average of 0.39 gN/m<sup>2</sup>d achieved during June and July when the highest rainfall was received. This improvement in ApANR could be due to the increase in ambient temperatures (which is assumed to mean a rise in wastewater temperature too) because of the change in seasons.

Figure 5.17 illustrates the internal performance of the NTF during Periods II B&C. The profiles are significantly different from the approximately linear profiles obtained during Period I-A. Hence, it has been deduced from these profiles that the biofilm activity was patchy due to non-homogenous biofilm growth. The steep profiles of May and June (Period II-B) are analogous with low removal rates and thus confirm the decline in apparent ANRs due to lack of optimum ventilation. The profiles for Period II-C (July, August and September) are less steep in comparison to Period II-B. However, some of the profiles indicate an increase in ammonia concentration in some areas of the TF. This anomaly is discussed further when the performance of the individual TF faces are inspected in order to further depict the internal behaviour in the subsequent sections of this chapter.

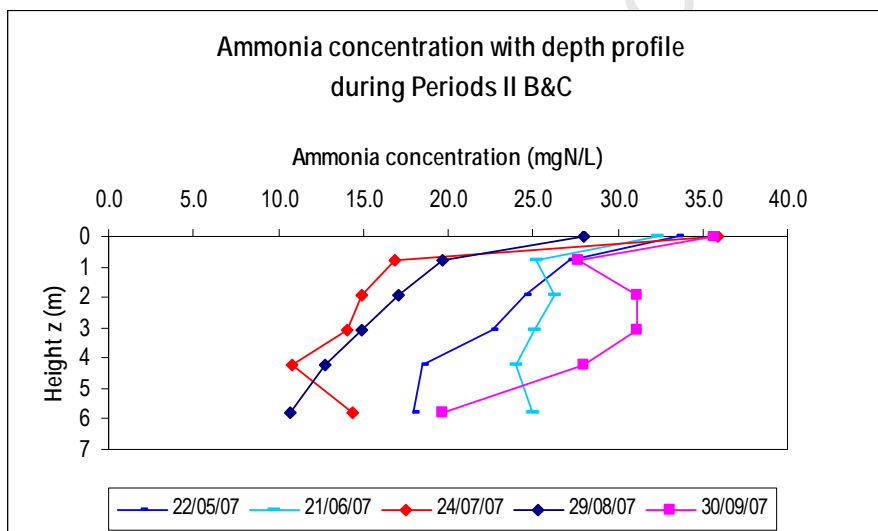

Figure 5.17: Internal ammonia concentration profile of the nitrifying trickling filter during Periods II B&C

Microbial analysis of the profile samples for Periods II B&C suggested that there was limited biofilm activity during this period of lower wastewater temperatures and high rainfall. The NTF was found to be riddled with fly remains and *Nematodae* and there was also an observed presence of true floc. The true

floc could not be further analysed in order to determine its constituencies because of the lack of specialised equipment during the investigation period.

### 5.3.3.1 Influent organic loading rates during Periods II B&C

Figure 5.18 illustrates the total ORR trend during Periods II-B&C. The ORRs appear to be more frequent in comparison to the empirical removal rates during Periods I and II-A.

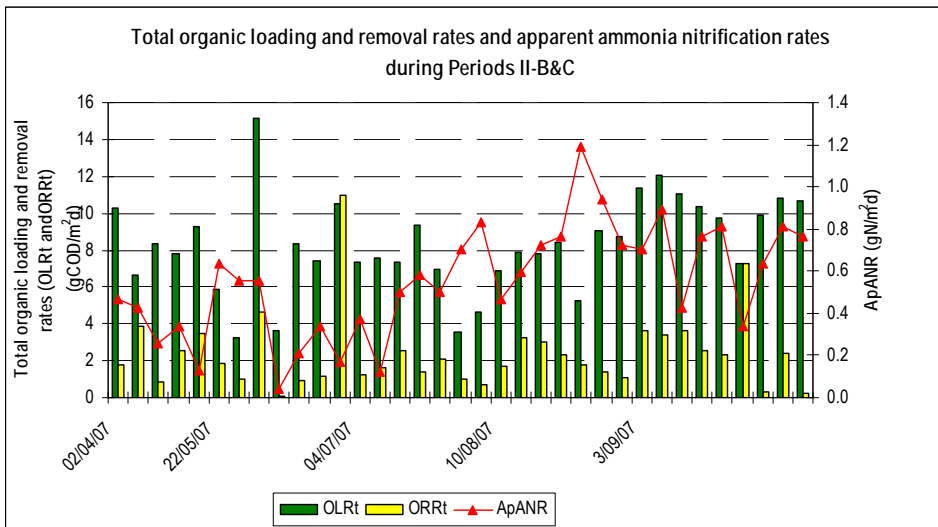

Figure 5.18: Total influent organic loading rates and organic removal rates and the apparent nitrification rates of the trickling filter during Periods II-B&C

The average total OLR during Periods II B&C are virtually the same at 8.97 and 9.96 gCOD/m<sup>2</sup>d respectively. These values are 12% and 2% less than the total OLRs reported during the summer period (Period I-A) respectively. However, the total ORRs (which are also virtually the same for periods B and C) are approximately 46% greater than the total ORRs observed during Period I-A. This further corroborates the assumption made previously that continued organic removal is likely to take place in the NTF due to the poor organic removal performance of the aerated lagoon during the winter season when low wastewater temperatures prevail. The soluble ORRs for Periods II B&C was 1.36 and 1.56 gCOD/m<sup>2</sup>d which corresponds to an apparent soluble biodegradable COD concentration removal of 32 and 38 mgCOD/l respectively. These apparent soluble biodegradable COD concentration are greater than the difference in the influent and effluent COD concentrations recorded in Table 5.7 (18 and 17 mgCO/l for Periods II B&C respectively). This is because the average removal rates include zero ORR instances when the influent COD concentration is less than the effluent. It has been presumed that soluble COD is sufficiently low to inhibit heterotrophic organism growth competition (should be less than 30 mgCOD/l Parker *et al.*, 1986).

The lack of adequate supply of oxygen to the media during Period II-B may have contributed to the poor apparent nitrifying performance of the NTF.

### 5.3.4 NITROGEN BALANCE OVER THE FULL-SCALE INVESTIGATION PERIOD

In this section, the observed ammonia concentrations removed by the NTF during the investigation period are compared with the  $\text{NO}_3 + \text{NO}_2$  (which is abbreviated as  $\text{NO}_x$  in this report) test results and the theoretical ammonia concentration removed as a consequence of the consumption of alkalinity in the TF. The consumed alkalinity was converted to ammonia by dividing the measured alkalinity consumption by 7.14 (WRC, 1984). Table 5.8 summarises the reconciliation of nitrogen over the NTF during the different operating periods.

Table 5.8 Full- scale nitrogen balance on the NTF performance during the investigation period

	FSA	$\text{NO}_3 + \text{NO}_2$	$\text{NO}_2$	Alkalinity
Period	$\Delta \text{ mgN/l}$	$\Delta \text{ mgN/l}$	$\Delta \text{ mgN/l}$	$\Delta \text{ mg/l as CaCO}_3$
I	19.8	35.6	5.6	169 [23.7] <sup>1</sup>
II-A	12.1	Nd <sup>2</sup>	nd <sup>2</sup>	nd <sup>2</sup>
II-B	9.4	13.1	1.1	nd <sup>2</sup>
II-C	14.4	4.5	0.6	98 [13.7] <sup>1</sup>

<sup>1</sup>The value in [ ] is the theoretical  $\Delta$ ammonia concentration =  $\Delta$ Alkalinity/7.14

<sup>2</sup>no data

During Period I-A, under which maximum ApANRs were recorded, the  $\text{NO}_x$  production and the theoretical approach of calculating the removed ammonia concentration as a consequence of the consumed alkalinity was 180% and 120% greater than the measured ammonia concentration from the FSA test. The significant discrepancies in the nitrogen results from these tests make the results inconclusive in verifying the optimum ApANR observed during this period. However, the internal performance of the NTF illustrated in Figure 5.7 substantiates these apparent removal rates. The discrepancies in the tests results could be due to the long waiting periods (approximately 3-4 weeks) before the samples could be analysed for  $\text{NO}_x$  and alkalinity. The profile samples, which were used to describe the internal performance of the NTF, were only analysed for ammonia concentrations. The samples were filtered on site and analysed with in a period of 72hrs.

There was insufficient data to determine the nitrogen balance during Period II-A and because no profile samples were collected during this period, hence the apparent nitrifying performance of the TF could not be verified.

During Period II-C, a nitrogen balance of 95% was achieved when reconciling the results obtained from the FSA test with the theoretical measurement of the removed ammonia concentration and a 31% nitrogen balance was obtained with the reconciliation of the  $\text{NO}_x$  and FSA results. The internal behaviour of the NTF cannot be used in this case to conclusively support to observed ammonia

concentrations removed because the profiles were non-linear and in some cases showed signs of an increase in ammonia concentration with depth. There was also no evidence of prolific internal nitrifying biomass activity from the conclusions drawn from the microbial analysis.

The reconciliation of the FSA and NO<sub>x</sub> results was generally poor. Therefore, it is recommended that in the future, test should be done as soon as the samples are collected in order to avoid the discrepancies found in Table 5.8, which may be due to some biological activities that could have taken place in the preserved samples. The alkalinity test is not time dependent; it has been assumed the long waiting periods should not have had a significant effect on the accuracy of the measurements. It has also been presumed that preserving and freezing the samples would have been adequate to inhibit further biological activity in order to ensure correct COD, FSA and nitrate and nitrite measurements. The discrepancies in the nitrogen balance results seem to refute this assumption.

### 5.3.5 INTERNAL AMMONIA REMOVAL PERFORMANCE OF THE INDIVIDUAL FACES OF THE NITRIFYING TRICKLING FILTER

The performance of the individual faces is discussed in further detail taking into account the ammonia concentration with depth profile and the microbial analysis findings of each face. Microbial analyses were not carried on the profile samples of the NTF collected during the summer period, hence only the ammonia profile graphs during the winter are discussed in this section. Nonetheless, the ammonia profile graphs of the individual faces for the summer period can be found in Appendix G.

#### 5.3.5.1 Internal performance of the West face

Due to the structural design of the NTF influent wastewater distribution system, the first two sampling ports at the top of the West face generally exhibited poor media wetting even under maximum HLR 2.8 m/hr. The West face was the only face to have full function of its fan throughout the investigation period. The relationship of the ammonia concentration with depth is expected to be a 'smooth' linear function with no interruptions, which implies that the nitrifying biofilm decreases uniformly with depth, as previously mentioned. The ammonia concentration profile of the West face, as illustrated in Figure 5.19 deviates significantly from the expected uniform linear relationship.

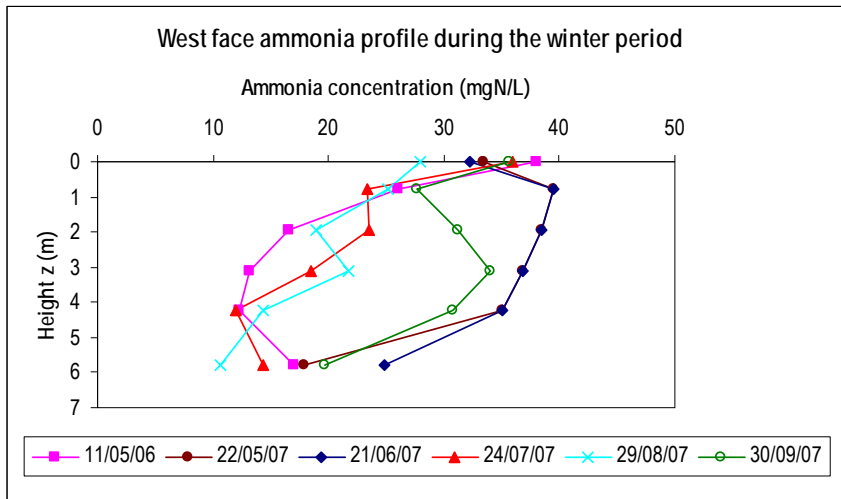

Figure 5.19: Internal ammonia concentration profile of the West face during the winter period

For most of the profiles observed during the winter period, there seems to be an increase in ammonia concentration particularly from the samples taken from the second and third sampling ports. It could be due to the ammonia released when the chitinous exoskeleton of the filter fly and other particulates are broken down in the TF. However, it is doubtful that the released ammonia is as significant as it appears to be in some of the profiles in Figure 5.19 and all the other profile faces (Figures 5.20 to 5.22). For most of the winter period of 2007 there was a fair amount of protozoans, fly remains, algae and floc present. Although the West face did show some ammonia removal, it is doubtful whether a homogenous nitrifying biofilm existed during the winter period.

### 5.3.5.2 Internal performance of the East face

The East face, as mentioned before, displayed the poorest media wetting of all the TF faces due to the wastewater distribution design. The fan on the East face was out of order for a period of three months (March to May 2007). The ammonia concentration profile is not a smooth linear function with depth (Figure 5.20). During most of the profile samples collection, no samples were collected from the first and second sampling ports due to the virtually zero flow through these sampling ports, thus an average of the ammonia concentrations from the other sampling ports on the same level has been used for the respective sampling ports. Hence, these ammonia concentrations from the first and second sampling ports are estimates and not the actual ammonia profile concentrations.

There was also a displayed increase in ammonia concentration with depth from some sampling ports. In some cases, the ammonia concentration from the last sampling port was less than the NTF effluent sump concentration, which resulted in an apparent increase in ammonia concentrations as illustrated in Figure 5.20. This was found to be the case in most of the NTF individual face's ammonia concentration profiles for the summer and winter periods. The NTF effluent sump sample is essentially an average of

the all the individual faces' ammonia concentrations. It could be that some faces have a final (fourth port sample) ammonia concentration which is less than the 'average' from the effluent sump hence resulting in an apparent increase in ammonia profile concentration from the last sampling ports.

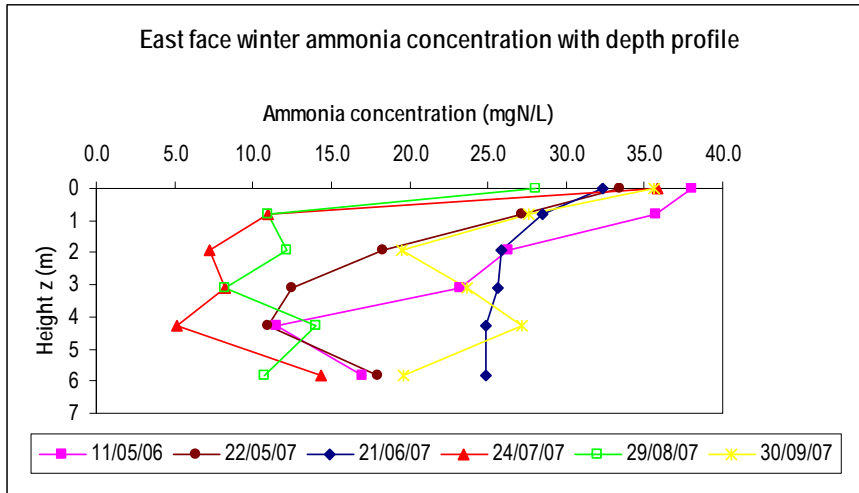

Figure 5.20: Internal ammonia concentration profile of the East face during the winter period

The East face exhibited the poorest nitrifying performance compared to the other faces. The microbial analysis of the samples during the winter period showed a significant presence of algae, fly debris, *Nematodae* and traces of true floc during the months from June to September. During May, the drier month in terms of total rainfall received, there was a significant presence of fly larvae and egg deposits in the profile samples. The East face profile samples had the most significant presence of algae. This may be because the East face is exposed to direct sunlight for the longest period over a 24-hour period compared to the other faces, because the sun rises in an east-northerly direction.

### 5.3.5.3 Internal performance of the South face

The South face showed good media wetting throughout the investigation period. It was exposed to very little direct sunlight over a 24-hour period and is thus expected to have the least presence of algae, which was the case. The South fan was out of order for the longest period of all the fans during the investigation period. The fan was out of order for a period of 8 months (Oct 2006 to May 2007), which was mainly during the summer season.

The ammonia concentration profile of this face is also not a 'smooth' linear relationship (Figure 5.21). There also appears to be an increase in ammonia concentration between the second and third sampling ports. The microbial analysis of the South face profile samples showed limited traces of algae, a high dominance of motile higher order protozoans and true floc with elements of endogenous residue. On occasion, there was a presence of fly debris and *Nematodae* during the drier months of May and

August. The South face showed more positive signs of nitrifying biofilm activity compared to the other faces.

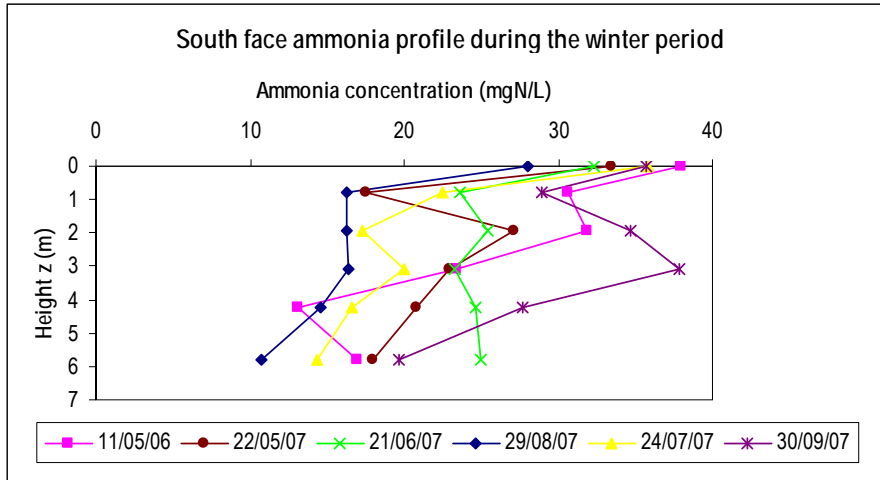

Figure 5.21: Internal ammonia concentration profile of the South face during the winter period

#### 5.3.5.4 Internal performance of the North face

In general, the North face showed evidence of good media wetting with the exception of the last sampling port that displayed poor wetting rates even under HLRs > 3.0 m/hr.

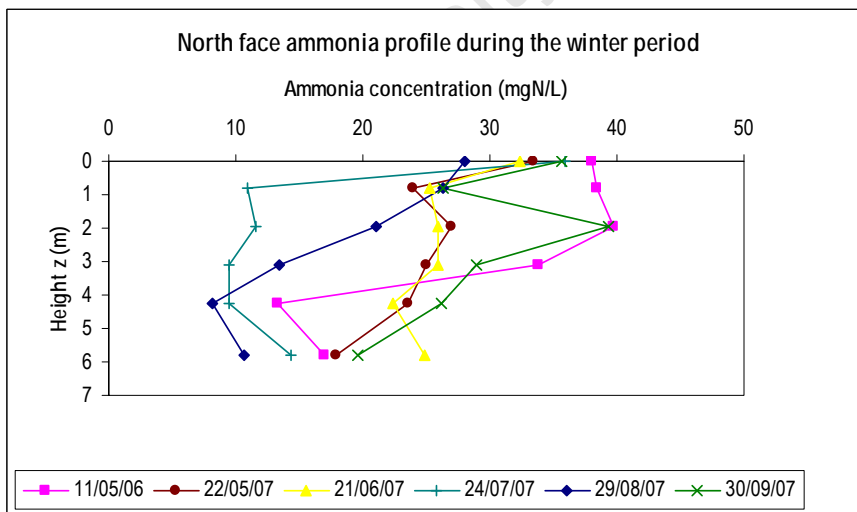

Figure 5.22: Internal ammonia concentration profile of the North face during the winter period

The North face was also exposed to direct sunlight for a considerable length of time during the day because of the sun's movement from an east-northerly to a west-northerly direction over a 24-hour period. Figure 5.22 illustrates the ammonia profile of the North face, which like the other profiles, is not a 'smooth' linear relationship of ammonia concentration with depth. Similar to the other faces too, there is an apparent increase in ammonia concentration with depth between the second and third sampling ports and the fourth and effluent sump samples.

Microbial analysis of the north profile showed a predominance of filter fly remains and *phacus* algae which were on occasion more pervasive than the East face. During the months of higher rainfall, *nematodae*, *rotifers* and fly debris were observed. Traces of true floc and a presence of fly hairs were found in the August profile samples. It is also doubtful whether there was any presence of nitrifying biomass during the winter period of 2007 because the microbial activity that was observed is deemed to have a negative effect on biofilm growth.

#### 5.4 INTERNAL NITRIFICATION RATES OF THE FULL-SCALE NITRIFYING TRICKLING FILTER

The internal ammonia nitrification rates were calculated by taking ammonia profiles which did not include ammonia concentrations of less than 5.0 mgN/l and did not exhibit any increases in ammonia concentration with depth. The calculation procedure was discussed in detail in Chapter 2. Figure 5.23 illustrates how the TF media sections have been divided.

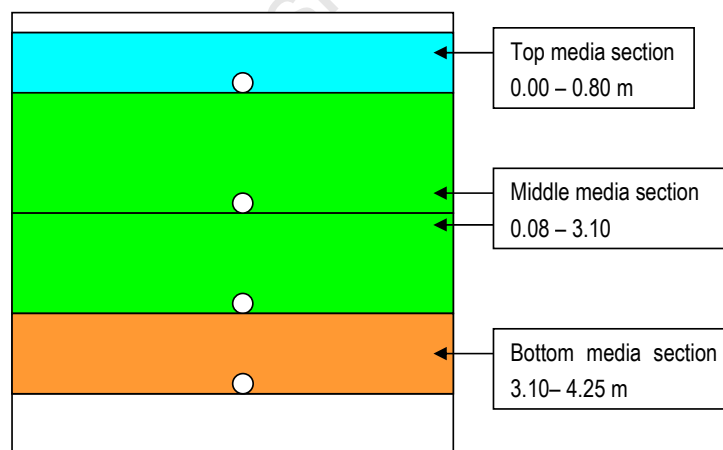

Figure 5.23: Internal trickling filter media sections associated with actual nitrification rates

Figure 5.23 illustrates the actual internal nitrification rates of the NTF as a function of depth. It has been found in literature that nitrifiers are unable to compete in the upper regions of NTFs because high

organic biodegradable COD concentrations enhance the growth of faster-growing heterotrophic bacteria, which deplete the oxygen near the top of the media (Parker *et al.*, 1986). Hence, it was expected that good removal rates should prevail in the middle section (0.80-1.95 m and 1.95-3.10 m) of the TF media. It was presumed that the soluble and particulate biodegradable COD concentrations will be sufficiently low to eliminate competition against biofilm growth and that there would be adequate dissolved oxygen concentration to allow for a more homogenous biofilm growth on this region of media. On the contrary, the bottom (3.10-4.25 m) and the middle (0.80-1.95 m and 1.95-3.10 m) sections of the media were found to exhibit similar actual nitrification rates. The performance of the bottom media section is usually under ammonia-limited conditions because of the decrease in ammonia concentrations with depth through the NTF. However, it is improbable that the middle section could also be operating under ammonia-limited conditions as this would mean that the top media section (0.00 – 0.80) removes over 80% of the influent ammonia concentration. This was found to not be the case, the top section of the TF media removes on average 30 – 40% (6.3 to 11.0 mgN/l) of the influent ammonia concentration under optimal operating conditions when there is prolific biofilm activity.

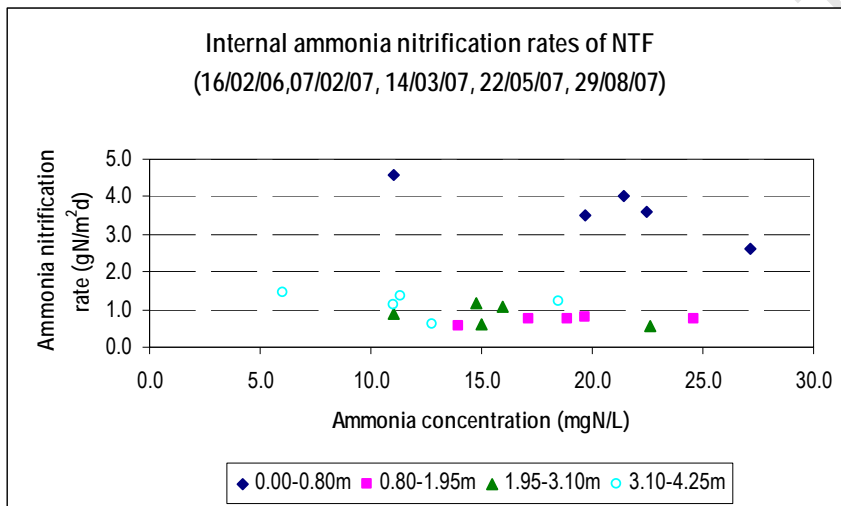

Figure 5.24: Internal ammonia nitrification rates during the investigation period

The ammonia concentration profiles illustrated an increase in ammonia concentration with depth that was observed on all of the individual NTF profiles between the second and third sampling ports (media depth from 0.80 m to 3.10 m which is regarded as the middle section). The poor performance in this media section could be due to *Phacus* algae proliferation that dominated the media surface area, consequently having a negative effect on the biofilm growth. Furthermore, on the exterior wall of the TF, there is visible algal growth on a year-round basis but particularly during the summer period. In order for the algae to grow on the external wall, there must be wastewater leaking from the TF in the regions of the algal growth. Hence, it could be that the extensive leaking of the TF may lead to non-homogenous wastewater distribution over the media and consequently patchy biomass growth. This however, does not explain the apparent increase in ammonia concentration with depth as experience on some individual profiles but it may explain the poor removal rates in this section of the media. The top

section of the media 0.00-0.80 m was found to exhibit the highest actual ANR. Table 6.5 shows the organic removal rates that were observed under the reported actual ANRs in the top section of the TF media.

Table 5.9: The effect of organic removal rates on actual internal ammonia nitrification rates

Date	Particulate organic removal*	Soluble organic removal*	Actual ANR 0.00-0.08 m	Actual ANR 0.80-1.95 m
	gCOD/m <sup>2</sup> d	gCOD/m <sup>2</sup> d	gN/m <sup>2</sup> d	gN/m <sup>2</sup> d
16/02/06	nd <sup>1</sup>	0.00	4.59	0.58
07/02/07	3.87	0.00	4.01	0.73
14/03/07	0.00	0.00	3.58	0.81
22/05/07	1.45	2.63	2.64	0.74
29/08/07	0.77	0.77	3.59	0.71

<sup>1</sup>nd = no data

\* These organic removal rates are the apparent removal rates over the NTF and not profile removal rates

These organic removal rates, reported in Table 5.9, are not the profile removal rates rather they are the observed average ORRs by the NTF. Nevertheless, they have been included to highlight the actual performance of the NTF in the presence or absence of organic removal rates. The data in Table 5.9 suggests that the lower internal ANRs that were observed are not significantly influenced by the apparent removal rates. The lower actual ApANRs during March could have been due to the lower dissolved oxygen concentrations because of the two fans that were out of operation from March to May 2007. The poor performance observe during May was because of the lower seasonal temperatures typical of the winter period coupled with poor ventilation. The high actual removal rates in the top media section suggest that the organic removal rates take place in the middle section of the TF media which is in contradiction to the findings from literature. However, this observation is yet to be verified with profile soluble and particulate COD concentrations with depth; in this research, the profile samples were only analysed for ammonia concentrations.

## 5.5 CONCLUSIONS

The structural design of the NTF at Citrusdal has the following shortcomings:

- The two-phase brick wall was inadequate in containing the wastewater loaded on the TF due to the excessive leaking of the TF that was observed during the investigation period. It was also penetrated by sunlight, which stimulated the growth of motile algae on the TF media. The presences of algae in the NTF is presumed to have had a negative effect on nitrifying biomass growth.

- The distribution of the influent and effluent wastewater systems was designed in such a way that the pressure of the water through the sprinklers decreases from the West to the East. Hence, the East face exhibited poor media wetting throughout the investigation period even at maximum HLRs > 2.8 m/hr.
- The nozzle sprinklers were sensitive to suspended particulates (which were usually in the form of algae) in the TF influent and recycle flows. During summer under high algal proliferation, the sprinklers were frequently clogged resulting in a reduction of the hydraulic output of the influent and recirculation sprinkler systems.
- The initial pumps (BHS 1.5 kW) that were used for the TF effluent recirculation system were not robust enough for continual use and were sensitive to the suspended solids in the effluent sump which required their filters to be cleaned on a regular basis (every 2 to 3 days).

These structural shortcomings resulted in inadequate media wetting conditions, which have a negative impact on the nitrifying performance of the NTF.

The NTF showed improved ApANRs during the summer period (warmer wastewater temperatures) compared to the winter period (colder wastewater temperatures) provided the operating HLRs were > 2.0 m/hr. Maximum ApANRs of 1.00 gN/m<sup>2</sup>d were recorded during the summer period; this is equivalent to a mass removal of 23.1 kgN/d and a removal efficiency of 70-85%. The observed removal rates meet the research objective of achieving ApANRs > 1.0 gN/m<sup>2</sup>d or removal efficiencies of greater than 80%.

The nitrifying performance of the TF is sensitive to low HLRs (less than 2.0 m/hr) especially during the summer period. Citrusdal receives high rainfall during the winter period, hence the TF media wetting is improved during the rainy winter period. The ApANR increased by approximately 49%, from 0.46 to 0.85 gN/m<sup>2</sup>d, when the HLR was increased from 1.4 to 2.3 m/hr during the summer period.

The NTF was subjected to higher total OLRs during the summer period due to prolific algal growth in the lagoon and TF effluent sump. However, higher organic removal trends were observed during the winter period compared to the summer. Soluble and particulate ORR trends exhibited random instances of high removal rates and virtually zero rates. It has been concluded that the random increases in the total ORRs exhibited by the NTF cannot solely explain poor performance of the NTF which was observed at times. The exclusive extent to which the observed total ORR effected the ApANRs could not be ascertained.

Lack of adequate ventilation was detrimental to the performance of the NTF especially during the winter period (colder wastewater temperatures). It is presumed that under such conditions, the transfer of oxygen was significantly affected by temperature. Maximum ApANRs of 0.72 gN/m<sup>2</sup>d were achieved during the winter period of 2007. However, these removal rates were not supported by the microbial analysis results or the ammonia concentration with depth profiles. The high winter rainfall dilutes the ammonia concentration in the open wastewater surfaces such the oxidation pond, the NTF and the TF effluent sump. Hence, good ApANRs achieved during the rainy months may be a consequence of the

wastewater dilution and not prolific biomass activity. Non-linear ammonia profiles were observed from profiles collected during the rainy winter season, under HLRs < 2.0 m/hr during the summer season and under insufficient ventilation during the winter season. This indicates patchy biofilm growth explains the low ApANRs performance of the NTF under the abovementioned operating conditions. The ammonia profile was linear under maximum ApANRs achieved during the summer period.

AcANRs illustrated that there was limited biofilm activity in the middle section of the NTF media. The top section of the TF media removed the highest mass of ammonia per media surface area - AcANRs of 2.6 to 4.6 gN/m<sup>2</sup>/d were observed. This corroborates the findings that the soluble biodegradable COD concentrations removed are sufficiently low allow for the biomass to develop on the top TF media section under optimum operating conditions. The presence of motile algae observed from the profile samples of the middle TF media section has had a negative impact on the growth of the nitrifying biofilm, which would explain the poor actual nitrification rates observed on this media section.

A poor nitrogen balance was achieved because of the significant discrepancies in the results obtained from the FSA and NO<sub>3</sub> + NO<sub>2</sub> and alkalinity tests. The long waiting periods (3 to 4 weeks) before the samples were analysed for the respective tests could have had an effect on the accuracy of the tests results even though the samples were preserved, filtered and frozen until they were analysed for the respective tests. However, the internal performance and microbial analysis of the NTF substantiate the apparent nitrifying performance of the NTF.

## CHAPTER 5: RESULTS AND DISCUSSION ON THE FULL SCALE NITRIFYING TRICKLING FILTER PERFORMANCE

5.1	OVERVIEW OF THE NITRIFYING PERFORMANCE DURING THE INVESTIGATION PERIOD	5-1
5.1.1	Overview of the influent organic loading on the nitrifying trickling filter	5-4
5.1.2	Effect of increased hydraulic loading on the nitrifying performance	5-6
5.1.3	Overview of the internal ammonia profile of the nitrifying trickling filter	5-8
5.2	INTERNAL BEHAVIOUR OF THE NITRIFYING TRICKLING FILTER	5-12
5.2.1	Media wetting	5-12
5.2.2	Microbial analysis of the profile samples	5-14
5.2.3	Predator proliferation	5-16
5.3	PERFORMANCE OF THE NTF DURING SELECTED OPERATING PERIODS	5-16
5.3.1	Performance of the nitrifying trickling filter during Period I-A	5-17
5.3.1.1	Influent organic loading rate during Period I-A	5-18
5.3.2	Performance of the nitrifying trickling filter during Period II-A	5-19
5.3.2.1	Influent organic loading rate during Period II-A	5-20
5.3.3	Performance of the nitrifying trickling filter during Period II-B&C	5-21
5.3.3.1	Influent organic loading rates during Periods II B&C	5-24
5.3.4	Nitrogen balance over the full-scale investigation period	5-25
5.3.5	Internal ammonia removal performance of the individual faces of the nitrifying trickling filter	5-26
5.3.5.1	Internal performance of the West face	5-26
5.3.5.2	Internal performance of the East face	5-27
5.3.5.3	Internal performance of the South face	5-28
5.3.5.4	Internal performance of the North face	5-29
5.4	INTERNAL NITRIFICATION RATES OF THE FULL-SCALE NITRIFYING TRICKLING FILTER	5-30
5.5	CONCLUSIONS	5-32

Table 5.1	Average ambient maximum and minimum air temperatures and rainfall data during the full-scale investigation period	2
Figure 5.1:	Apparent ammonia nitrification rate (ApANR) performance of the trickling filter during the investigation period (20/02/06 – 30/09/07)	2
Table 5.2:	Summary of the apparent ammonia nitrification rates of the NTF during the investigation period from February 2006 to September 2007	3
Figure 5.2a:	Influent and effluent soluble COD concentrations and associated organic removal rates during the summer period 2006 and 2007	4
Figure 5.2b:	Influent and effluent soluble COD concentrations and associated organic removal during the winter period 2006 and 2007	5
Figure 5.2c:	Influent and effluent soluble COD concentrations and associated organic removal during the summer period 2006 and 2007	5
Figure 5.2d:	Influent and effluent particulate COD concentrations and associated organic removal during the winter period 2006 and 2007	6
Table 5.3:	Trickling filter recirculation pumps inventory during the investigation period of the research	7
Figure 5.3:	Effect of the hydraulic loading rate (HLR) on the apparent ammonia nitrifying performance of the trickling filter (20/02/06 – 30/09/07)	8
Figure 5.4:	Diagram of the East and South faces of the Citrusdal trickling filter	9
Figure 5.5:	Average internal ammonia concentration profile of the nitrifying trickling filter during the investigation summer period	10
Table 5.4:	Apparent ammonia nitrification rate of the NTF with 2 of the 4 forced air ventilation fans in operation	10
Figure 5.6:	Average internal ammonia concentration profile of the nitrifying trickling filter during the investigation winter period	11
Figure 5.7:	Profile sample positions along the NTF media depth	12
Figure 5.8:	Influent flow distribution network of the NTF	13
Figure 5.9:	A summary of the media wetting through East and South faces	13
Figure 5.10:	A summary of the wetting rate through West and North faces	14
Figure 5.11:	Leaking on the North face during the investigation period	15
Table 5.5:	Operating parameters during Period I-A	17
Figure 5.12:	Average internal ammonia concentration profile of the nitrifying trickling filter during Period I-A	18
Figure 5.13:	Total (includes soluble and particulate) organic loading and removal rates and apparent ammonia nitrification rates during Period I-A	19
Table 5.6:	Operating parameters during Period II-A	20
Figure 5.14:	Effect of the ammonia loading rate on the ammonia nitrification rate of the trickling filter Period II-A	20
Figure 5.15:	Total influent organic loading rates and organic removal rates and the apparent ammonia nitrification rates of the trickling filter during Period II-A	21
Table 5.7:	Operating parameters during Periods II-B&C	22

Figure 5.16: Effect of the ammonia loading rate on the apparent ammonia nitrifying performance of the trickling filter during Periods II B&C	22
Figure 5.17: Internal ammonia concentration profile of the nitrifying trickling filter during Periods II B&C	23
Figure 5.18: Total influent organic loading rates and organic removal rates and the apparent nitrification rates of the trickling filter during Periods II-B&C	24
Table 5.8 Full- scale nitrogen balance on the NTF performance during the investigation period	25
Figure 5.19: Internal ammonia concentration profile of the West face during the winter period	27
Figure 5.20: Internal ammonia concentration profile of the East face during the winter period	28
Figure 5.21: Internal ammonia concentration profile of the South face during the winter period	29
Figure 5.22: Internal ammonia concentration profile of the North face during the winter period	29
Figure 5.23: Internal trickling filter media sections associated with actual nitrification rates	30
Figure 5.24: Internal ammonia nitrification rates during the investigation period	31
Table 5.9: The effect of organic removal rates on actual internal ammonia nitrification rates	32

Formatted: Tab stops: 2.5", Left

## CHAPTER 6

# APPARENT NITRIFYING PERFORMANCE OF THE LABORATORY-SCALE NITRIFYING TRICKLING FILTER

The laboratory-scale external nitrification (EN) nitrifying trickling filter (NTF) experiment was initiated in an endeavour to assess its performance under a controlled environment; given the numerous limitations experienced at the full-scale investigation at Citrusdal. These limitations have been discussed in Chapter 1. The main ones were; the remoteness of the Citrusdal WWTP, lack of testing facilities and the lack of full time dedicated staff. The laboratory experiment was not a scaled down replica of the full-scale NTF at Citrusdal. The plastic spherical balls used for media in the laboratory-scale NTF makes its performance more comparable to rock media trickling filters (TFs) than high specific surface area plastic media.

The objective was to achieve apparent ammonia nitrification rates (ApANRs) of at least 1.0 gN/m<sup>2</sup>d or greater or ammonia removal efficiencies > 80%. This chapter highlights the effect that hydraulic loading rates (HLRs) have on the apparent nitrifying performance. The measure of apparent nitrification rates was described in Chapter 2; essentially the internal performance of the NTF is not taken into account in the calculation of apparent nitrification rates, which is the mass of the ammonia removed (the difference in TF influent and effluent ammonia mass) per total media surface area (Figure 2.2, Chapter 2). The internal performance of the laboratory experiment was not assessed because there were no profile sampling ports on the TF. A comparison of the optimum performance of the laboratory- and full-scale nitrifying trickling filters (NTFs) is made with maximum nitrification rates that have been published in literature for rock and plastic media TFs.

### 6.1 START-UP NITRIFYING TRICKLING FILTER PERFORMANCE

The laboratory experiment is a single stage operated TF with a cross-section area of 0.02 m<sup>2</sup> filled with plastic media of a 109 m<sup>2</sup>/m<sup>3</sup> media specific surface area. The plastic media, which is made up of hollow plastic spherical balls, has a total length of 1.48 m. The effluent required for external nitrification (EN) should be similar to that of the anaerobic reactor supernatant, being very low in suspended solids and organics and high in ammonia, which is discharged on the NTF in the EN BNRAS system. The laboratory-scale NTF was designed to operate as a tertiary unit that treats final effluent from the UCT NDBEPR membrane system. This effluent has virtually zero suspended solids, low soluble COD and ammonia concentrations and a relatively high nitrate concentration. The effluent was dosed with an ammonium chloride solution to increase the ammonia concentration to ensure non ammonia limiting operating conditions in the NTF.

Table 6.1 summarises the initial calculation for the required influent ammonia concentration at the start of the experiment. The ammonia concentration removed by the system was initially set at 25 mgN/l because this was the maximum concentration removed at the full-scale investigation at Citrusdal. At the start of the experiment, the NTF treated 100L/d of wastewater and this was increased to 200L/d over the experimental period of 335 days in order to find the optimum HLR rate that will result in maximum ApANRs.

**Table 6.1: Ammonia dosing calculation**

Parameter	Unit	Calculation
$A_t$	3.34 m <sup>2</sup>	reactor specific
ApANR <sup>a</sup>	0.75 gN/m <sup>2</sup> d	$N_{rem} * Q_i / A_t$ (fixed)
$Q_i$	100 L/d	fixed
$N_{rem}$	25 mgN/l	fixed
$N_e$	5 mgN/l	$N_i - N_e$ (calculated)
$N_i$	30 mgN/l	varied

Abbreviations:  $A_t$  = total media surface area

<sup>a</sup> apparent ammonia nitrification rate

The experiment was carried out under constant laboratory temperature of 20°C. The trickling filter was inoculated with nitrifiers by recirculating activated sludge for a period of two weeks prior to feeding it with the final effluent from the UCT membrane system at the start of the experiment. This was in order to accelerate biofilm development on the TF media. The initial influent hydraulic loading conditions were such that TF influent flowrate and the TF effluent recycle flowrate had a common pumping source. In this manner the effect that ammonia loading rates (ALRs) and HLRs had on the performance of the NTF were coupled. An increase in the pump out put increased both the ALR and the HLR equally. Table 6.2 summarises the performance of the NTF during the start-up period.

**Table 6.2: Operating parameters during the start-up period of the laboratory-scale NTF**

Parameters	Start-up period Units	Nov 2006-Feb 2007			
		Ave	SSD	Max	Min
No of data		20			
$Q_{influent}$	L/d	108			
$Q_{recycle}$	L/d	108			
$N_{influent}$	mgN/l	44.2	14.9	68.8	14.4
$N_{effluent}$	mgN/l	36.6	16.2	64.0	2.94
ALR	gN/m <sup>2</sup> d	1.36	0.48	2.19	0.44
ApANR <sup>a</sup>	gN/m <sup>2</sup> d	0.23	0.11	0.44	0.02
HLR	m/hr	0.42			

<sup>a</sup> Apparent ammonia nitrification rate

The initial operating parameters are listed in Table 6.2. The recycle ratio was 1.1 with respect to the influent flowrate and the influent ammonia concentration was greater than 30 mgN/l. The effluent wastewater from the UCT NDBEPR membrane system, which was nitrified by the TF, was presumed to have soluble COD concentrations that were on average less than 50 mgCOD/l and assumed unbiodegradable. Hence, during this start-up period, influent and effluent samples were not analysed for soluble COD.

ApANRs of 0.23 gN/m<sup>2</sup>d were achieved during the start up period from November 2006 to February 2007 (120 days). Due to the poor performance of the NTF, it was decided that the design of the NTF should be revised to decouple the effects of the ammonia and hydraulic loading rates in order to allow for more flexibility in independently varying the parameters with the aim of significantly improving the performance of the NTF. It was also decided that analysis for soluble COD should be done in order to verify the influent COD concentrations.

## 6.2 THE EFFECT OF INCREASED HYDRAULIC LOADING RATES ON THE NITRIFYING PERFORMANCE

The laboratory-scale NTF was revised as illustrated in Figure 4.1 (Chapter 4) which allowed for independent entry points for the TF influent flow and effluent recycle and hence independent pumping sources. The performance of the NTF has been summarised into four operating periods. The main distinction between these operating periods is the hydraulic loading rate (HLR). The objective was to find the optimum HLR that would result in ApANRs > 1.0 gN/m<sup>2</sup>d.

**Table 6.3: Performance of the laboratory-scale NTF under different experimental periods**

Period	Date	No. days	Q <sub>i</sub> L/d	Q <sub>R</sub> L/d	HLR m/hr	N <sub>ai</sub> mg/l	N <sub>ae</sub> mg/l	ALR gN/m <sup>2</sup> d	A <sub>p</sub> ANR <sup>1</sup> gN/m <sup>2</sup> d
1	08/03/07- 08/06/07	91	101	158	0.58	46.4	25.5	1.40	0.59
2	09/06/07- 30/06/07	21	101	230	0.66	32.1	10.6	0.97	0.65
3	01/07/07- 14/08/07	45	144	230	0.74	40.5	18.4	1.74	0.95
4	15/08/07- 30/09/07	46	202	230	0.86	39.4	10.8	2.37	1.72

Abbreviations; N<sub>ai</sub>= influent ammonia concentration, N<sub>ae</sub> = effluent ammonia concentration, Q<sub>i</sub> = influent flowrate, Q<sub>r</sub> = recirculation flowrate

<sup>1</sup> apparent ammonia nitrification rates

Table 6.3 summarises the performance of the NTF under the different experimental periods. During Period 1 (March to end of June), the total HLR was increased by increasing the operating recirculation ratio from 1:1 to 1:1.16 (with respect to the influent flowrate) while the ALR remained unchanged. ApANRs improved by 59% (from 0.23 gN/m<sup>2</sup>d to 0.59 gN/m<sup>2</sup>d). Although this was a significant improvement, the ApANRs in Period 1 were substantially less than the minimum objective removal rates of 1.0 gN/m<sup>2</sup>d. There was also a significant number of adult flies observed outside the TF and there were worms visible on the media. The poor performance of the NTF during Period I-A could be due to the filter flies that colonised the media as a consequence of inadequate media wetting conditions during the start-up period. Therefore, it was decided to increase the recirculation flowrate with the aim of eradicating the dry patches on the TF media, which would have been presumably colonised by fly larvae. Hence, during Period 2 the recycle flowrate was further increased to 230 L/d, which was more than double the influent flowrate (recycle ratio of 1:2.3). The ammonium chloride dosage was reduced in order to operate at the initial estimated influent ammonia concentration of 30 mgN/l. There was a 10% improvement in ApANRs during Period 2 with the NTF operating under predominantly ammonia-limited conditions. Consequently, the influent ammonia concentration was increased to approximately 40 mgN/l during Period 3 of NTF operation. In addition, the influent flowrate was also increased by 43% in order to increase the ALRs by 79% compared to the loading conditions during Period 2.

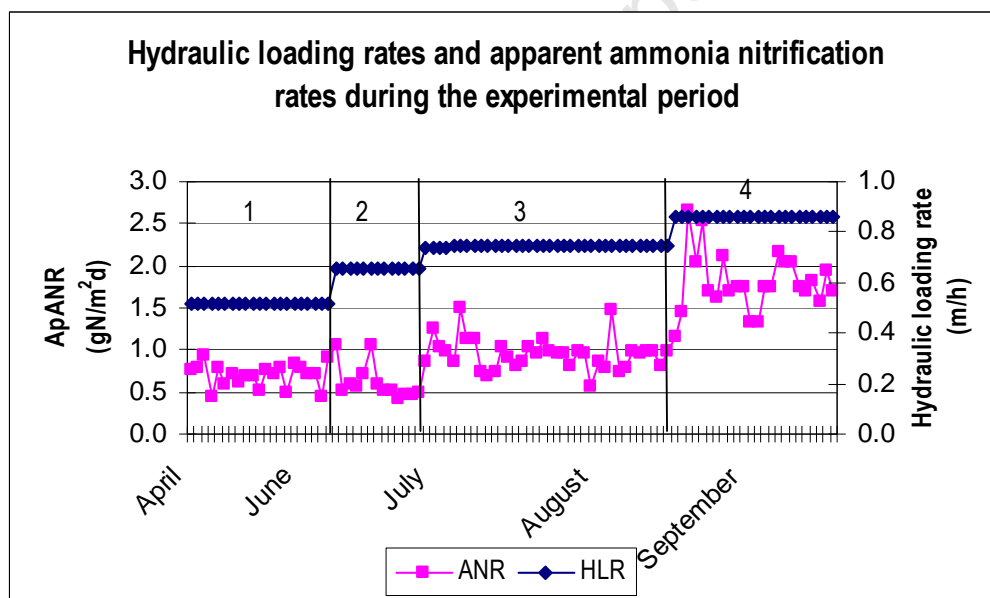

Figure 6.1: Effect of the hydraulic loading rate on apparent ammonia nitrification rates at laboratory-scale

Figure 6.1 illustrates the sensitivity of ApANRs to influent hydraulic loading conditions at laboratory scale. Due to time constraints, it could not be verified whether the maximum apparent ApANR of 1.72 gN/m<sup>2</sup>d (SSD 0.43) achieved was the steady state performance of nitrifying biofilm at laboratory-scale under the operating conditions of Period 4.

Maximum removal efficiency of approximately 80% was achieved for a short period during June (Period 2). However, the high removal rates are not indicative of optimum operating conditions because the ApANRs of 0.58 gN/m<sup>2</sup>d (ALR = 0.72 gN/m<sup>2</sup>d) were obtained under ammonia-limited conditions (effluent ammonia concentration < 5.0 mgN/l). During Period 3, maximum ApANR of 0.95 gN/m<sup>2</sup>d which equivalent to a removal efficiency of 55% of the ALR (of 1.74 gN/m<sup>2</sup>d). This means that the optimum ammonia removal capacity of the biofilm under these high ALRs given hydraulic loading conditions is 55% of the influent ammonia mass. Hence, high removal efficiencies are not necessarily an indication of maximum nitrification rates. During Period 4, which is marked by the notable increase in ApANRs in Figure 6.2, the average removal efficiency achieved was 74%. This is equivalent to an average mass removal of 5.77 gN/d or ApANRs of 1.72 gN/m<sup>2</sup>d when the average ALR was 2.37 gN/m<sup>2</sup>d.

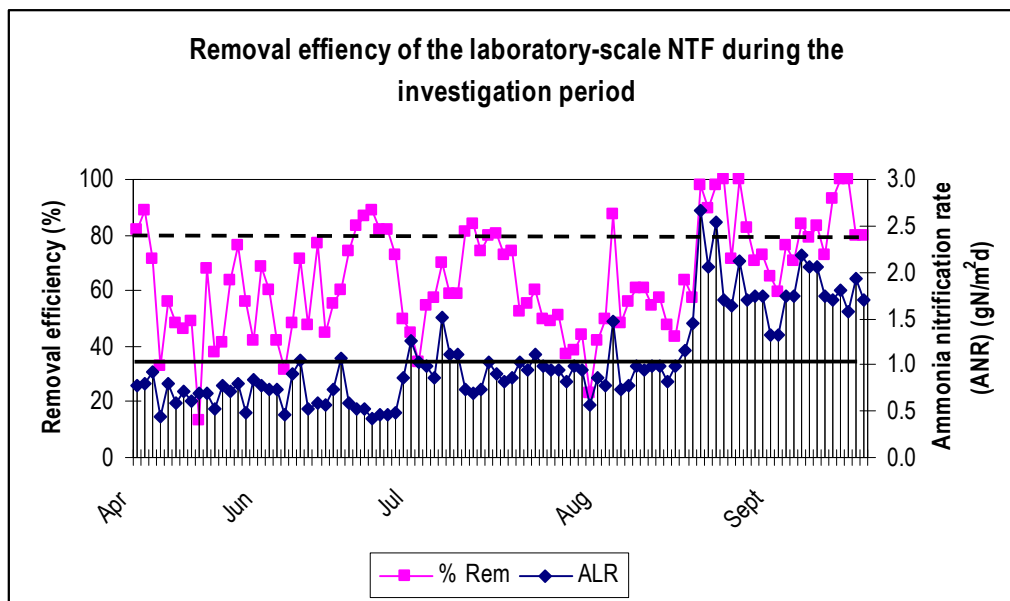

Figure 6.2: Effect of the ammonia loading rate on apparent ammonia nitrification rates during the investigation period

Table 6.4 is a summary of the ammonia concentrations through the NTF from Periods 1 to 3 (April to mid-August 2006).

Table 6.4: Ammonia concentrations through the laboratory-scale nitrifying trickling filter during Period 1, 2 and 3

Parameter	Unit	PERIOD 1				PERIOD 2				PERIOD 3			
		Ave	Max	Min	ssd	Ave	Max	Min	ssd	Ave	Max	Min	ssd
HLR	m/hr	0.58				0.66				0.74			
N <sub>influent</sub>	mgN/L	46.4	72	24	7.8	32.1	68	18	13.1	40.5	70	19	11.9
N <sub>effluent</sub>	mgN/L	25.5	50	4	8.3	10.6	28	2	9.3	18.4	46	3	11.0
ALR	gN/m <sup>2</sup> d	1.40	2.17	0.73	0.24	0.97	2.05	0.54	0.40	1.74	3.02	0.82	0.51
ApANR <sup>a</sup>	gN/m <sup>2</sup> d	0.59	1.08	0.02	0.27	0.65	1.24	0.48	0.13	0.95	1.51	0.56	0.19

The average effluent ammonia concentrations during these was  $> 5.0$  mgN/l, however the minimum effluent ammonia concentration was  $< 5.0$  mgN/l. Table 6.4 together with Figure 6.4 has been used to illustrate the effect that ammonia limited conditions (effluent ammonia concentrations  $< 5.0$  mgN/l) have on ApANRs.

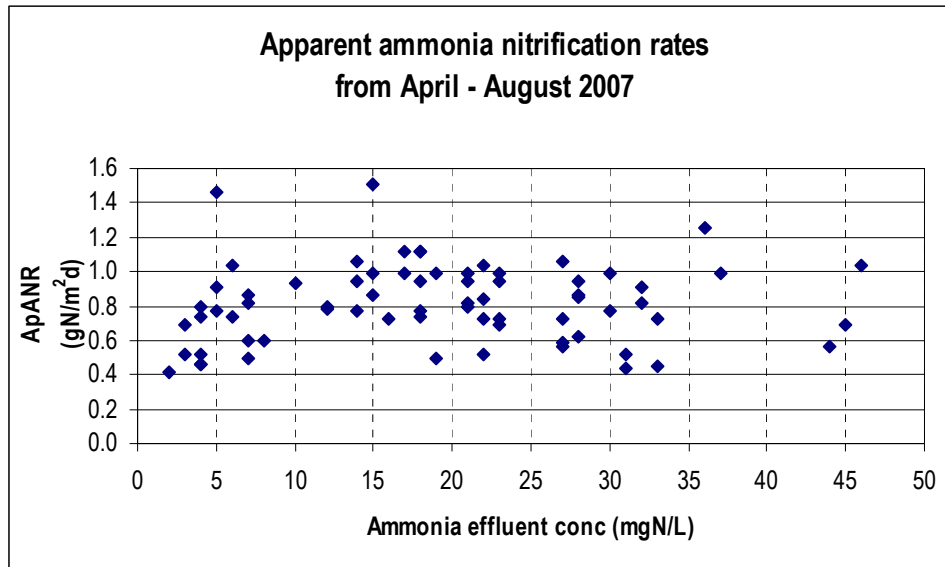

**Figure 6.3: Apparent ammonia nitrification rates of the laboratory-scale nitrifying trickling filter (April to August 2007)**

Ammonia-limited conditions occurred when the ApANRs were between 0.4 to 0.8 gN/m<sup>2</sup>d with corresponding ALRs from 0.5 to 1.1 gN/m<sup>2</sup>d and effluent ammonia concentrations  $< 5.0$  mgN/l. By the end of Period 3, the average ApANR was 0.95 gN/m<sup>2</sup>d (SSD 0.19) under HLRs 0.74 m/hr (over a period of 144 days). The HLR was increased to determine whether there would be any significant improvement to the ApANRs. During Period 4, the influent flow rate was increased from 144L/d during Period 3 to 202 L/d with the recirculation flow rate remaining constant at 230L/d. The influent ammonium chloride dosage was increased accordingly to give an average influent ammonia concentration of 39.4 mgN/l, which is virtually the same as the influent concentration of Period 3. This resulted in a 36% increase in ALRs from Period 3 to 4 and an 87% improvement in ApANRs from 0.95 to 1.72 gN/m<sup>2</sup>d. The improvement in ApANRs as a result of increasing the HLR confirms the sensitivity of the NTF to HLRs observed in Figure 6.1.

### 6.3 NITRIFYING TRICKLING FILTER PERFORMANCE UNDER SOLUBLE ORGANIC LOADING RATES

Table 6.5 summarises the organic loading and removal rates observed during the investigation period.

**Table 6.5: Performance of the laboratory-scale NTF under different experimental periods**

		$Q_i$	$Q_R$	HLR	$A_p\text{ANR}^1$	ALR	$\text{SCOD}_i$	SOLR	SORR
Period	Date	L/d	L/d	m/hr	$\text{gN/m}^2\text{d}$	$\text{gN/m}^2\text{d}$	$\text{mgCOD/l}$	$\text{gCOD/m}^2\text{d}$	$\text{gCOD/m}^2\text{d}$
1	08/03/07-08/06/07	101	158	0.52	0.59	1.40	38	1.14	0.00
2	09/06/07-30/06/07	101	230	0.66	0.65	0.97	38	1.14	0.00
3	01/07/07-14/08/07	144	230	0.74	0.95	1.74	46	1.89	0.32
4	15/08/07-30/09/07	202	230	0.86	1.72	2.37	45	2.70	0.00

<sup>1</sup>Apparent ammoni nitrification rates

Abbreviations:  $\text{SCOD}_i$  = influent soluble COD; SOLR = soluble organic loading rate; SORR = soluble organic removal rate;  $Q_i$  = influent flowrate;  $Q_r$  = TF effluent recycle flowrate

On average, the influent soluble COD concentration during the investigation period was 55 mgCOD/l (SSD 8). The effluent COD concentration on average was approximately 50 mgCOD/l. The negligible COD removed by the system is reflected by the virtually zero soluble organic removal rates (SORR) observed during the investigation period (see Table 6.5). The higher organic removal rates during Period 3 may be due to changes in the characteristics of the matter that makes up the COD fed to the laboratory scale MLE. The system is fed with raw sewage collected from the Mitchells Plein wastewater treatment works in Cape Town, South Africa. New batches of sewage are collected every two weeks. However, during the same period (Period 3),  $A_p\text{ANR}$  of 0.95  $\text{gN/m}^2\text{d}$  were achieved. It is evident from the results in Table 6.5 that the HLR contributed to the improvement in  $A_p\text{ANR}$ s while the influent COD concentration was sufficiently low to not significantly impact on the nitrifying performance of the trickling filter.

## 6.4 NITROGEN BALANCE

A nitrogen reconciliation of the results from the FSA,  $\text{NO}_3 + \text{NO}_2$  and the consumed alkalinity were used to verify the apparent nitrifying performance of the TF. The ammonia removed by the NTF was theoretically calculated by dividing the consumed alkalinity by 7.14 (WRC, 1984). In this dissertation, the  $\text{NO}_3 + \text{NO}_2$  production is denoted as  $\text{NO}_x$ .

**Table 6.6: Nitrogen balance on the laboratory-scale performance during the experimental period**

	FSA	NO <sub>3</sub> + NO <sub>2</sub> ≡ NO <sub>x</sub>	NO <sub>2</sub>	NO <sub>3</sub>	Alkalinity
Period	Δ mgN/l	Δ mgN/l	Δ mgN/l	Δ mgN/l	Δ mg/l as CaCO <sub>3</sub>
1	20.9	28.2	1.5	25.7	130 [18.2] <sup>1</sup>
2	21.5	24.7	3.4	21.3	111 [15.5] <sup>1</sup>
3	22.1	29.3	7.0	22.3	149 [20.1] <sup>1</sup>
4	28.6	32.6	5.8	26.8	176 [30.2] <sup>1</sup>

<sup>1</sup>The value in [ ] is the theoretical Δammonia concentration = ΔAlkalinity/7.14

The wastewater fed to the NTF had an average influent NO<sub>x</sub> concentration of 28.3 mgN/l of which the NO<sub>2</sub> concentration was 1.22 mgN/l. Due to significant influent nitrate concentration values it could not be ascertained whether the NO<sub>2</sub> production was from the NO<sub>3</sub> that was converted by the nitrifying biomass in the TF or from the influent NO<sub>3</sub> concentration. The NO<sub>3</sub> concentration was significantly higher than the nitrogen concentration from the FSA test and the theoretical nitrogen production using the alkalinity consumed in the TF (see Table 6.6). This could be due to errors in the nitrate test procedure. A sample volume of 5 ml had to be diluted fifty times in order to obtain good readings from the nitrates test machine (auto analyser). It is likely that this factor had a significant effect on the accuracy of the nitrate concentration measurements. The discrepancies may also be due to systematic errors of the nitrates and nitrites machine.

During Period 1 (HLR = 0.52 m/hr and ALR = 1.40 gN/m<sup>2</sup>d), a nitrogen balance of 87% was achieved by comparing the FSA results with the alkalinity measurements; 123% with the NO<sub>3</sub> production. The NO<sub>x</sub> production was 30% greater than the observed ammonia removal, which indicates complete nitrification of the influent ammonia. The NTF operated under ammonia limited conditions during Period 2 (HLR = 0.66 m/hr and ALR = 0.97 gN/m<sup>2</sup>d) and there was an observed prevalence of filter flies and worms. The alkalinity measurement yield a nitrogen balance of 72% (with respect to the FSA results) which could be due the effect of the of the predator and ammonia-limited conditions. A 99 and 116% nitrogen balance was achieved with the NO<sub>3</sub> and NO<sub>x</sub> production respectively with respect to the FSA results.

During Period 3 under HLRs of 0.74 m/hr the prevalence of filter flies ceased but the worms were not eradicated; the ALR was increased to 1.97 gN/m<sup>2</sup>d to avoid ammonia-limited conditions. A nitrogen balance of 91 and 100% was achieved with the alkalinity measurements and NO<sub>3</sub> production respectively with respect to the FSA results. The NO<sub>x</sub> production was 33% higher than the FSA results in Table 6.6.

During Period 4 where the highest ApANRs were recorded under HLRs of 20.6 m/d and ALRs of 2.37 gN/m<sup>2</sup>d, a nitrogen balance of 106 and 94% was achieved by reconciling the FSA results with the alkalinity measurements and the NO<sub>3</sub> production respectively. The nitrogen balance confirms the

maximum removal rates obtained during the experimental period. However, the  $\text{NO}_x$  production was 14% greater than the FSA results during this period.

In Table 6.5, it is evident that denitrification occurred in NTF through the investigation period and in some cases up to 33% of the influent ammonia concentration was denitrified. This is attributed to the inefficiency of the spherical ball plastic media to effectively transfer oxygen throughout the TF, similar to rock media, rather than insufficient oxygen supply. The oxygen transfer inefficiency results in dead spaces with no oxygen. Under such conditions, denitrification takes place, hence the notable  $\text{NO}_2$  concentrations observed during the experimental period.

## 6.5 COMPARISON OF THE INVESTIGATION RESULTS WITH LITERATURE

The apparent nitrifying performance of the full-scale and laboratory scale NTF was compared with the maximum nitrification rates obtained under optimal operating conditions in literature (Table 6.7). The maximum performance of the Citrusdal NTF is most comparable with the findings by Parker *et al.* (1989) on their investigation on a pilot-scale single stage, cross-flow plastic media NTF. The treatment capacity of the Citrusdal NTF is two order of magnitudes less than that of Parker *et al.* (1989) which removed a maximum ammonia mass of 3792 kgN/d compared to 23.1 kg/d at Citrusdal. Average ANRs (which were only calculated for ammonia concentrations  $> 5$  mgN/l) of 2.3 gN/m<sup>2</sup>d were achieved by Parker *et al.* (1989). At Citrusdal ApANRs of 1.00 gN/m<sup>2</sup>d were achieved under operating HLRs of 2.3 m/hr compared to 5.0 m/hr in Parker *et al.* (1989) investigation. The Citrusdal NTF may have the potential to achieve higher ApANRs with increased HLRs above 2.0 m/hr.

The plastic spherical balls, which make up the media of the laboratory-scale NTF, are more comparable with the spherical rock media TF in the investigation by Muller *et al.* (2006). This is because although the surface type of media of the rock and plastic spheres differs, both media occupy a low void ratio, which makes them less efficient for oxygen transfer throughout the media and their shape does not offer maximum exposure surface area for biofilm growth compared to cross flow plastic media.

Under a controlled environment, the laboratory-scale NTF achieved maximum ApANRs of 1.72 gN/m<sup>2</sup>d (which is equivalent to a removal efficiency of 72%) under ALRs of 2.37 gN/m<sup>2</sup>d and HLRs of 0.86 m/hr. The full-scale rock media achieved apparent removal rates of 1.25 gN/m<sup>2</sup>d under ALRs of 1.42 gN/m<sup>2</sup>d and total HLRs of 2.6 m/hr (1.3 m/hr per NTF). Furthermore, lower effluent ammonia concentrations were achieved due to the superior performance of two-stage operation of TFs (Muller *et al.*, 2006).

Table 6.7: Comparison of the optimal operating conditions found in literature and laboratory- and full-scale results of this research

Parameter	Units	SOURCE					
		Parker <i>et al.</i> , 1989	Parker <i>et al.</i> , 1995	Parker <i>et al.</i> , 1997	Muller <i>et al.</i> , 2006	Mofokeng <i>et al.</i> , 2008	Mofokeng <i>et al.</i> , 2008
Research type		Pilot-scale	Pilot-scale	Full-scale	Full-scale	Full-scale	Laboratory-scale
No. of NTFs		1	2	2	2	1	1
Q <sub>i</sub>	ML/d	237 x 10 <sup>6</sup>	np	121 x 10 <sup>6</sup>	10.6 x 10 <sup>6</sup>	0.96 x 10 <sup>6</sup>	202 x 10 <sup>6</sup>
Media depth	m	6.7	3.6	7.3	3.6	5.4	1.48
Media type		Plastic Cross flow	Plastic Cross flow	Plastic Cross flow	Rock	Plastic Cross flow	Spherical plastic balls
Media density	m <sup>2</sup> / m <sup>3</sup>	138	140	138	45	142	109
Media surface area	m <sup>2</sup>	1 405	3 563	810 199	115 560	23 100	3.34
Temperature	°C	15	15	16.5	22.4	np	20
HLR	m/hr	5	5	4	2.6	2.3	0.86
ALR	gN/m <sup>2</sup> d	np	2.4	1.68	1.42	1.4	2.37
ApANR	gN/m <sup>2</sup> d	2.3 <sup>b</sup>	2.1 <sup>a</sup>	1.57 <sup>a</sup> (1.73) <sup>b</sup>	1.25 <sup>a</sup>	1.00 <sup>a</sup>	1.72 <sup>a</sup>
Eff. ammonia conc.	mgN/l	14	2.4	1.85	2.37	8.0	10.9
Ammonia removed	mgN/l	16	17.2	24.8	14.8	24.1	28.5
Influent sol. COD conc.	mgCOD/l	7.6	9.9 <sup>1</sup>	11.9 <sup>2</sup>	80-100	81	56
Influent TSS conc.	mgTSS/l	7.7	16.0	14.8	31.7	164 <sup>3</sup>	nil

a = Apparent nitrification rates and b = Average nitrification rates calculated by only considering oxygen-limited region NTFs

<sup>1</sup> 9.9 BOD<sub>7</sub> mg/l

<sup>2</sup> 11.9 CBOD<sub>5</sub> mg/l

<sup>3</sup> 164 mgCOD/l which is particulate

The laboratory-scale NTF performance was also compared to the pilot-scale 2 stage, cross-flow NTF media investigated by Parker *et al.* (1995) based on similar ALRs. The laboratory-scale apparent removal rates were 18% less than the actual ANRs achieved by Parker *et al.* (1995). The two-stage pilot-scale investigation by Parker *et al.* (1995) was expected to exhibit better nitrifying performance because; it employs plastic cross-flow media, which is most efficient for external nitrification application and operating the NTFs in series leads to homogenous biofilm growth and lower NTF effluent ammonia concentrations < 5.0 mgN/l as concluded from the literature review (Chapter 2). However, it is also evident that the laboratory-scale and rock media NTFs can achieve good ammonia removal rates based on the total mass of ammonia removed per media surface even though these type of media are less efficient for optimal external nitrification application.

Relatively good ApANRs were achieved with high influent soluble COD concentrations from the investigations carried out by Muller *et al.* (2006) and Mofokeng *et al.* (2008) in Table 6.7. These reported COD concentrations include both biodegradable and unbiodegradable COD content.

## 6.6 CONCLUSIONS

Maximum apparent removal rates of 1.72 gN/m<sup>2</sup>d (equivalent to a removal efficiency of 72%) were achieved under HLRs of 20.6 m/d. The laboratory-scale results meets the objective of achieving ApANRs of greater than 1.0 gN/m<sup>2</sup>d and although the removal efficiency achieved was less than the objective of 80%; the achieved 72% removal efficiency was regarded as adequate because of the relatively high ALRs of 2.37 gN/m<sup>2</sup>d.

The laboratory-scale nitrifying performance was found to be sensitive to hydraulic loading conditions. ApANRs improved by 45% from the pseudo steady state operation of the NTF during Period 3 when the HLR were increased by 13% and the ALR by 27% during the optimum ApANRs observed during Period 4. The average influent COD concentration of 56 mgCOD/l was sufficiently low to not have an impact on ApANRs

Although there were no profile samples taken, there were visible worms on the TF media throughout the investigation period. There was also a prevalence of adult filter flies observed around the outside of the NTF but they disappeared under HLRs > 0.66 m/hr. A nitrogen balance of 106 and 114% with respect to the alkalinity consumption measurements and NO<sub>x</sub> production verifies the maximum apparent removal rates of 1.72 gN/m<sup>2</sup>d achieved during the experimental period. There was evidence of denitrification nitrification throughout the experimental period. This is ascribed to the inefficient oxygen transfer of the plastic spherical balls media used.

<b>6.1</b>	<b>START-UP NITRIFYING TRICKLING FILTER PERFORMANCE</b>	<b>6-1</b>
<b>6.2</b>	<b>THE EFFECT OF INCREASED HYDRAULIC LOADING RATES ON THE NITRIFYING PERFORMANCE</b>	<b>6-3</b>
<b>6.3</b>	<b>NITRIFYING TRICKLING FILTER PERFORMANCE UNDER SOLUBLE ORGANIC LOADING RATES</b>	<b>6-6</b>
<b>6.4</b>	<b>NITROGEN BALANCE</b>	<b>6-7</b>
<b>6.5</b>	<b>COMPARISON OF THE INVESTIGATION RESULTS WITH LITERATURE</b>	<b>6-9</b>
<b>6.6</b>	<b>CONCLUSIONS</b>	<b>6-11</b>

Table 6.1:	Ammonia dosing calculation	2
Table 6.2:	Operating parameters during the start-up period of the laboratory-scale NTF	2
Table 6.3:	Performance of the laboratory-scale NTF under different experimental periods	3
Figure 6.1:	Effect of the hydraulic loading rate on apparent ammonia nitrification rates at laboratory-scale	4
Figure 6.2:	Effect of the ammonia loading rate on apparent ammonia nitrification rates during the investigation period	5
Table 6.4:	Ammonia concentrations through the laboratory-scale nitrifying trickling filter during Period 1, 2 and 3	5
Figure 6.3:	Apparent ammonia nitrification rates of the laboratory-scale nitrifying trickling filter (April to August 2007)	6
Table 6.5:	Performance of the laboratory-scale NTF under different experimental periods	7
Table 6.6:	Nitrogen balance on the laboratory-scale performance during the experimental period	8
Table 6.7:	Comparison of the optimal operating conditions found in literature and laboratory- and full-scale results of this research	10

## CHAPTER 7

### CONCLUSIONS AND RECOMMENDATIONS

The principal objective of this research investigation was to achieve apparent ammonia nitrification rates (ApANRs) of 1.0 gN/m<sup>2</sup>d and greater or ammonia removal efficiencies exceeding 80% at full-scale and laboratory-scale investigations on external nitrification (EN) in nitrifying trickling filters (NTFs). Actual nitrification rates (AcANR) were only determined under the full-scale operation, from profile samples along the trickling filter (TF) media depth.

Under full-scale investigation the effect that the following parameters; changes in seasons, hydraulic loading rates (HLRs), ammonia loading rates (ALRs) and organic loading and removal rates have on the ApANRs were observed. The main objective of the laboratory investigation was to determine the effect that HLRs have on ApANRs. The conclusions and recommendations drawn from the findings of the full- and laboratory-scale investigations are discussed in this chapter.

#### 7.1 FULL-SCALE INVESTIGATION CONCLUSIONS

##### 7.1.1 APPARENT AMMONIA NITRIFICATION RATES

Average maximum ApANRs of 1.00 gN/m<sup>2</sup>d were achieved during the summer period (warmer wastewater temperatures) under HLRs of 2.3 m/hr compared to 0.62 gN/m<sup>2</sup>d achieved during the winter period (colder wastewater temperatures) under HLRs of 2.4 m/hr. The corresponding maximum ammonia removal efficiency achieved was 76% or ammonia mass removal 23.1 kgN/d under non ammonia-limited conditions (effluent ammonia concentrations > 5mgN/l). ApANRS increased by approximately 49%, from 0.46 to 0.85 gN/m<sup>2</sup>d, when the HLR was increased from 1.4 to 2.3 m/hr during the summer period.

The nitrogen mass balance for the maximum ApANR at full-scale were inconclusive. NO<sub>3</sub> and NO<sub>2</sub> and alkalinity balances of 180 and 120% respectively were obtained with reference to the FSA results. However, the ammonia concentration removed with depth profile substantiated the ApANRs of 1.00 gN/m<sup>2</sup>d. An approximately linear relationship of the ammonia concentration with depth was observed. This is indicative in a linear decline in biomass activity, which according to literature is associated with single-stage operated NTFs. The objective of obtaining ApANRs of 1.00 gN/m<sup>2</sup>d was achieved.

### 7.1.2 THE EFFECT OF ORGANIC LOADING RATES ON APPARENT AMMONIA NITRIFICATION RATES

The NTF at Citrusdal exhibited varying organic loading and removal rates in the summer and winter periods of the investigation. Increased soluble organic removal rates (SORRs) were observed during winter. This was due to the poor organic removal performance of the lagoon under cold wastewater temperatures resulting in lower biological kinetic rates. Hence, biodegradable organics continue to be degraded in the NTF after the lagoon. The higher soluble organic ORRs during the winter contributed to lower ApANRs observed during the same period. Particulate organic loading rates (POLRs) were on average higher during the summer compared with winter. This is due to algal proliferation in the lagoon during the warm summer period, resulting in higher suspended solids loads onto the NTF compared to winter. However, the PORR trend was erratic, high removal rates were observed sometimes and low removal rates at other times for no apparent reason. Particulate organic loading on the NTF is undesirable because it results in overgrowth and clogging of the media. The media may be blocked at certain areas because of the erratic flow distribution displayed from the profile samples.

### 7.1.3 THE EFFECT OF THE HYDRUALIC LOADING RATES ON APPARENT AMMONIA NITRIFICATION RATES

At Citrusdal, under HLRs of 1.3 m/hr (before the TF effluent recirculation system was installed), there was a prevalence of adult filter flies and worms observed from the profile samples which is indicative of dry media patches and patchy biofilm growth. This situation was exacerbated during summer where the average maximum and ambient temperatures were 33 and 16 °C respectively leading to high evaporation rates during the day. The average ApANRs during this period before the recirculation system was installed were 0.69 gN/m<sup>2</sup>d. Predator proliferation was dominant at low HLRs of 1.0-1.5 m/hr and ApANRs ranged between 0.3 to 0.5 gN/m<sup>2</sup>d under these hydraulic loading conditions. ApANRs of 0.85-1.0 gN/m<sup>2</sup>d were achieved during the summer at HLRs of 2.0-2.3 m/hr. The prevalence of filter flies and worms decreased but did not cease at HLRs > 2.0 m/hr.

The pervasiveness of adult flies was observed to be lower during the winter period. The high rainfall during the winter period contributes to improved media wetting hence making conditions less favourable for the development of filter fly larvae. Nevertheless, low ApANRs were observed during winter presumably due to the low wastewater temperature. The average ApANRs of 0.66gN/m<sup>2</sup>d obtained during the winter period were not corroborated by the internal performance of the TF and the results obtained from the analysis of the profile samples for microbial activity, which showed minimal activity. The internal performance of the NTF did not show a linear relationship of ammonia concentration with depth, which was the case when the average maximum ApANRs of 1.00 gN/m<sup>2</sup>d were achieved. This implies that there was limited biofilm activity during the winter period of the investigation.

#### 7.1.4 VENTILATION

The NTF performed best (ApANR of 1.00 gN/m<sup>2</sup>d) with at least 3 of the 4 fans in operation and under HLRs of 2.0-2.3 m/hr during the summer period (warmer wastewater temperature). The ApANRs decreased by 48% (from 0.85 gN/m<sup>2</sup>d to 0.41 gN/m<sup>2</sup>d) when two out of the four fans or more fans were in operation at the beginning of the winter period. It has been concluded from the observation that a combination of inadequate ventilation and colder wastewater temperatures may have lead to limited oxygen transfer to the biofilm that resulted in the decline in ApANRs.

#### 7.1.5 INTERNAL NITRIFYING PERFORMANCE OF THE FULL-SCALE NTF

The internal nitrifying performance of the NTF was determined by plotting ammonia concentration with depth profile. During the summer period under HLRs of > 2.0 m/hr there was a linear decrease in ammonia concentration with depth from the top of the TF indicating homogenous biofilm activity. Under HLRs < 2.0 m/hr, the NTF was colonised by filter flies and the ammonia concentration with depth profiles were non linear which is indicative of patchy biofilm growth as a consequence of the larvae grazing on the biomass. ApANRs obtained during the winter period did not correspond with linearly decreasing ammonia concentration with depth profiles despite HLRs > 2.0 m/hr. Significant traces of algae and presence of worms (*Nematodae*) and to a lesser extent filter flies (*Physcoda*) were observed in the profile samples during the winter period. The observed limited biofilm activity (due to the non-linear ammonia concentration with depth profiles) during the winter period has been attributed to colder wastewater temperatures, increased ORRs, the presence of worms and algae and inadequate ventilation (when 2 fans were out of order).

The AcANRs indicated that the top media section (0.00 – 0.80) of the NTF has the highest AcANRs (3.05 gN/m<sup>2</sup>d) and the middle section (0.80 – 3.10 m) exhibited lower AcANRs (0.66 gN/m<sup>2</sup>d) similar to the bottom media section (3.10 – 5.80) where AcANRs of 0.68 gN/m<sup>2</sup>d were observed. The high AcANRs observed in the top the media layer indicate establish biofilm activity. The AcANRs in the middle media section were expected to be of value in between AcANRs observed in the top and low media sections. The poor performance in the middle media section could be ascribed to the significant presence of algae in the profile samples especially from the NTF walls, which are exposed to direct sunlight for the longest time over a 24-hour period. Growth of motile algae within the NTF may have led to media clogging which retards the hydraulic pathway and may also have had a negative impact on biofilm attachment to media.

### 7.1.6 STRUCTURAL DESIGN OF THE CITRUSDAL NITRIFYING TRICKLING FILTER

The NTF is a single-phase brick wall structure with a square cross sectional area. Excessive leaking of the two-phase wall was observed throughout the investigation period, the situation was exacerbated during under increased HLRs with the introduction of the TF effluent recycle. The growth of motile algae in the NTF is stimulated by sunlight penetrating the cracks of the TF brick well.

The unclarified TF influent from the lagoon had a significant presence of suspended solids (predominately in the form of algae) which clogged the nozzle sprinklers therefore reducing the flow. Hence, the wastewater distribution system was sensitive to the type of nozzle sprinklers used. The distribution system was inefficient in equally distributing the wastewater over the media and required frequent cleaning of the nozzles sprinklers to ensure that maximum HLRs were maintained. The inefficiency of the distribution system resulted in the East face always being subjected to inadequate media wetting conditions even under HLRs > 2.0 m/hr.

## 7.2 LABORATORY-SCALE INVESTIGATION CONCLUSIONS

### 7.2.1 APPARENT AMMONIA NITRIFICATION RATES

Under controlled laboratory conditions, where the temperature was kept constant at 20°C, maximum ApANRs of 1.72 gN/m<sup>2</sup>d were achieved at HLRs of 0.86 m/hr. The ammonia removal efficiency was 73%, which is equivalent to an ammonia mass removal 5.76 gN/d. These maximum ApANRs were achieved under non ammonia-limited conditions (effluent ammonia concentration > 5mgN/l). The ApANRs meet the principal objective of attaining ApANRs ≥ 1.0 gN/m<sup>2</sup>d.

Mass balances of 106 and 114% for alkalinity consumption and NO<sub>3</sub> and NO<sub>2</sub> production with respect to the free and saline ammonia (FSA) tests confirmed the maximum ApANR at laboratory scale.

### 7.2.2 EFFECT OF ORGANIC LOADING RATES ON APPARENT AMMONIA NITRIFICATION RATES

The average influent soluble COD concentration to the laboratory scale was 56 mgCOD/l and on most occasions, zero organic removal rates were observed. Hence, organic loading rates did not have a negative effect on ApANRs at laboratory scale.

### 7.2.3 THE EFFECT OF HYDRAULIC LOADING RATES ON APPARENT AMMONIA NITRIFICATION RATES

The HLRs of the laboratory unit (0.66 to 0.86 m/hr) were much lower than those of the full-scale unit (1.5 to 2.4 m/hr). At HLRs < 0.66 m/hr, there was a prevalence of adult filter flies and worms. The filter flies disappeared under HLRs > 0.66 m/hr but the worms were not eradicated even under HLRs of 0.86 m/hr when the highest ApANRs of 1.72 gN/m<sup>2</sup>/d were observed. The laboratory-scale NTF performance was sensitive to HLR conditions. ApANRs improved from 0.95 to 1.72 gN/m<sup>2</sup>/d with a 15% increase in HLRs.

## 7.3 RECOMMENDATIONS

The following recommendations are made from the conclusions drawn from the full-scale investigation:

- Samples need to be collected on a more regular basis in order to verify the organic and ammonia removal trends of the NTF.
- Samples should be analysed within a week in order to avoid the discrepancies in the nitrogen test results that led to inconclusive nitrogen reconciliation.
- Profile samples should be analysed for dissolved oxygen concentrations and wastewater temperature in order to determine the effect the temperature has on the dissolved oxygen utilization of the biofilm at full scale.
- Profile samples should also be analysed for alkalinity and nitrate/nitrite in order to check the mass balances on the data.
- Microbial analysis of the profile samples is required on a year-round basis to determine the effect of the seasons on the internal microbial activity.
- A clarifying unit is recommended to reduce the TF influent particulate organic loading rate.
- The two-phase brick wall is inadequate for the intended purpose of the NTF - it should be plastered with concrete to make it impervious to prevent wastewater from leaking out and sunlight penetrating in.
- Distribution nozzles that are insensitive to solids are should be used to decrease the maintenance requirement of the hydraulic loading system.
- Maximum ApANRs of 1.00 gN/m<sup>2</sup>/d were achieved under average effluent ammonia concentrations of 5.0 mgN/l which are greater than the standard effluent ammonia requirement of 3.0 mgN/l. In order to attain these low effluent ammonia concentrations without leading to ammonia-limited conditions, it is recommended that two NTFs should be operated in series.

7.1	FULL-SCALE INVESTIGATION CONCLUSIONS	7-1
7.1.1	apparent ammonia nitrification rates	7-1
7.1.2	The effect of organic loading rates on apparent ammonia nitrification rates	7-2
7.1.3	The effect of the hydraulic loading rates on apparent ammonia nitrification rates	7-2
7.1.4	Ventilation	7-3
7.1.5	Internal nitrifying performance of the full-scale ntf	7-3
7.1.6	Structural design of the Citrusdal nitrifying trickling filter	7-4
7.2	LABORATORY-SCALE INVESTIGATION CONCLUSIONS	7-4
7.2.1	Apparent ammonia nitrification rates	7-4
7.2.2	Effect of organic loading rates on apparent ammonia nitrification rates	7-4
7.2.3	The effect of hydraulic loading rates on apparent ammonia nitrification rates	7-5
7.3	RECOMMENDATIONS	7-5

Error! No table of figures entries found.

## 8. REFERENCES

1. Andersson, B., Aspegren, H., Parker, D.S., Lutz, M.P. (1994) *High rate nitrifying trickling filters*. Water and Science Technology, v 29, n 10-11, pp. 47-52
2. Balakrishnan, S and Eckenfelder, W (1968) *Nitrogen relationships in biological treatment processes – III. Denitrification in the modified activated sludge process*. Water Research v 3, pp. 177 – 188
3. Balakrishnan, S and Eckenfelder, W (1970) *Nitrogen removal by modified activated sludge process*. Sanitary engineering division: Proceedings of the American Society of Civil Engineers, v 96, No. SA2.
4. Boller, M., Gujer, W., and Tshui, M. (1994) *Parameters affecting nitrifying biofilm reactors*. Water and Science Technology, v 29, n 10-11, pp 1-11
5. Boller, M. and Gujer, W (1985) *Nitrification in tertiary trickling filters followed by deep-bed filters*. Water Research, v 20, n 11, pp 1363-1373
6. Ekama, G. and Marias GvR. *Chapter five: Nitrification*. CIV 5045 University of Cape Town post graduate course (2006).
7. Evans, E., Ellis, T., Gullicks, H. and Ringelestein, J. (2004) *Trickling filter nitrification performance characteristics and potential of a full-scale municipal wastewater treatment facility*. Environmental Engineering, v 130, No. 11
8. Gray, R., Ritland, G., Chan, R. and Jenkins, D. (2000) *A Nevada facility controls snails with centrate to meet stringent total nitrogen limits*. Water Environment and Technology, v 12 pp 80-83
9. Gullicks, H. and Cleasby, J. (1990) *Nitrification performance of a pilot-scale trickling filter*. Research Journal of Water Pollution and Control Federation, v 62, pp 933-936
10. Gullicks, H. and Cleasby, J. (1986) *Design of trickling filter nitrification towers*. Research Journal of Water Pollution and Control Federation, v 58, No. 1, pp 61-66
11. Gullicks, H. and Cleasby, J. (1990) *Discussion: Nitrification performance of a pilot-scale trickling filter*. Journal of Water Pollution and Control Federation, v 62, No. 40, pp 40-48
12. Gujer, W. and Boller, M. (1985) *Design of a nitrifying tertiary trickling filter based on theoretical concepts*. Water Research, v 20, n 11, pp 1353-1362
13. Hu, Z., Wentzel, M. and Ekama, G. (2000) *External nitrification in biological nutrient removal activated sludge systems*. Water SA, v 26, n 2, April 2000
14. Hu, Z., Sötemann, S., Vermande, S., Moodley, R., Little, C., Lakay, M., Wentzel, M. and Ekama, G. *External nitrification with aid of fixed media trickling filters (TF) to increase the capacity of biological nutrient removal (BNR) suspended medium activated sludge (AS) system. (2000) Water Research Commission, Report No.970/1/02*
15. Hu, Z., Sötemann, S., Vermande, S., Moodley, R., Wentzel, M. and Ekama, G. *Experimental investigation of the external nitrification biological nutrient removal activated sludge (ENBRAS) system*. Biotechnology and Bioengineering, v 83, pp 260-273
16. Lakay T., Wentzel M. and Ekama G. (2002) *Laboratory procedures – wastewater treatment laboratory*. Water research group, Department of Civil Engineering, University of Cape Town

## 8. REFERENCES

17. Logan, B., Hermanowicz, S. and Parker, D (1987a) *Engineering implications of a new trickling filter model*. Research Journal of Water Pollution and Control Federation, v 59, No. 12, pp 1017-1028
18. Logan, B., Hermanowicz, S. and Parker, D (1987b) *A fundamental model for trickling filter process design*. Research Journal of Water Pollution and Control Federation, v 59, No. 12, pp 1029-1041
19. Logan, B. (1993) *Oxygen transfer in trickling filters*. Journal of Environmental Engineering, v 119, No. 6, pp1059-1075
20. Lutz, M., Pratt, A., Parker, D. and Brischke, K. (1990) *Full-scale performance of nitrifying trickling filters*. Presented at 63rd WPCF Conference, Washington, DC, USA
21. Marias, GvR., Ekama, G and Wentzel, M. *Application of the activated sludge model to aerated lagoons*. CIV 5045 University of Cape Town post graduate course notes (2006).
22. Muller, A., Sötemann, S., Wentzel, M., Ekama, G., Saayman, G., Esterhuysen, C. and Snyman, J. (2004) *Practical implementation of external nitrification (EN) in biological nutrient removal activated sludge (BNRAS) systems*. Progress report to WRC, THRIP, Water and Sanitation Service SA (Pty) Ltd (local subsidiary of Ondeo, France. (Not Published)
23. Muller, A., Wentzel, M., Saayman, G., van der Merwe, S., Esterhuysen, C. and Snyman, J. and Ekama, G., (2004) *Fullscale implementation of external nitrification biological nutrient removal at the Daspoort Water Care Works, Tshwane Municipality, B*, Water SA, vol 30 No. 5 pp 585-591.
24. Muller, A., Wentzel, M. and Ekama, G. (2006a) *Estimation of nitrification capacity of rock media trickling filters in external nitrification BNR*. Procs. 9<sup>th</sup> biennial WISA conference and exhibition, Durban, 21-25 May 2006.
25. Muller, A., Wentzel, M., Saayman, G., Esterhuysen, C., Snyman J. and Ekama, G. (2006b) *Two-years operating experience of full-scale external nitrification BNR activated sludge*. Procs. 9<sup>th</sup> biennial WISA conference and exhibition, Durban, 21-25 May 2006.
26. Parker, D., Lutz, M. and Pratt, A. (1990) *New trickling filter applications in the USA*. Water and Science Technology, v 22, n 1/2, pp 215-226
27. Parker, D., Jacobs, T., Bower, E., Stowe, D. and Farmer, G. (1997) *Maximising trickling filter nitrification rates through biofilm control: Research review and full scale application*. Water Science and Technology, v 36, n 1, pp 255-262
28. Parker, D., Lutz, M., Andersson, B. and Aspegren, H. (1995) *Effect of operating variables on nitrification rates in trickling filters*. Water Environment Research, v 67, n 7, pp 1111-1118
29. Parker, D., Lutz, M., Dahl, R. and Bernkopf, S. (1989) *Enhancing reaction rates in nitrifying trickling filters through biofilm control*. Journal WPCF, v 61, n 5 pp 618-631
30. Parker, D. and Richards, T. *Nitrification in trickling filters*. (1986) Journal WPCF, V 58, n 9, pp 896-902
31. Parker, D. and Merrill, D. (1984) *Effect of plastic media configuration on trickling filter performance*. Journal WPCF, v 56, n 8, pp 955-961

## 8. REFERENCES

32. van Haandel, A and Marias, GvR (supervisor) (1981) *Nitrification and denitrification kinetic in the activated sludge process*. Research Report No.W.39
33. Siergrit, H and Gujer, W (1985) *Mass transfer mechanisms in a heterotrophic biofilm*. Water Research, v 19, m 11, pp 1369-1378
34. Siergrit, H and Gujer, W (1987) *Demonstration of mass transfer and pH effect in a nitrifying biofilm*. Water Research, v 21, n 12, pp 1481-1487
35. Stone, R., Parker, D. and Cotteral, J. (1975) *Upgrading lagoon effluent for best practicable treatment*. Research Journal of Water Pollution and Control Federation, v47, n 8, pp 2019-2041

University of Cape Town

**APPENDIX A:  
LITERATURE REVIEW – NITRIFYING TRICKLING FILTER  
MODELS**

University of Cape Town

## 1. NITRIFYING TRICKLING FILTER MODELS

This appendix is a summary of the various endeavours by investigators to model the nitrification performance of NTFs. There have been two categories to the approach of modelling NTFs. The empirical models that are based on apparent nitrification rates are discussed first, followed by the theoretical models that take into account the internal processes in the nitrifying biofilm and require actual nitrification rates.

### 1.1.1 EMPIRICAL NITRIFYING TRICKLING FILTER MODELS

The earliest attempt to model nitrogen removal in trickling filters was done by the U.S. Environmental Protection Agency (EPA) Process Design Manual for Nitrogen Control. The data was collected from trickling filters that followed primary and secondary treatment of COD. Secondary sedimentation was included before the NTF. The data was collected from a single-stage operated NTF with a TF media height of 6.55m packed with vertical-flow media with a media specific density of  $88.6 \text{ m}^2/\text{m}^3$ . Design curves were generated from the collected data to represent the relationship between desired effluent ammonium concentration and required media surface area. These curves were only applicable to NTF sites with the same physical parameters and for temperature ranges between  $7^\circ$  to  $10^\circ \text{ C}$ ,  $13^\circ$  to  $19^\circ \text{ C}$  and  $18^\circ$  to  $22^\circ \text{ C}$ . The application of the design curves was intended to be conservative.

Gullicks and Cleasby (1986) and Parker *et al.* (1989) found the EPA empirical design curves to contain data that exhibited excessive scatter and inaccuracy when applied to the same operating conditions as required. These findings led to the notion that there may be some underlying fundamental shortcomings with regards to the concept and accuracy of the curves. Gullicks and Cleasby (1986) attributed the lack of accuracy and scattered data found from using the EPA curves to; inaccurate calculation procedures and a failure to consider the effect that the loading conditions (hydraulic loading rates (HLRs) and ammonia loading rates (ALRs)) have on the removal capacity of NTFs when they are not adequately accounted for.

Gullicks and Cleasby (1986) proposed a series of design curves for modelling ammonia removal rates in TFs. These curves are based on the fixed-biofilm model (which has been discussed in Chapter 2) and the assumption that trickling filters are generally mass limited. The model takes into account the following variables; influent ammonia concentration, HLR and effects of recycling, and wastewater temperature.

Even though the design concept of the curves is based on the theoretical fixed biofilm theory of the nitrifying biomass, the curves were calibrated using empirical data, which is based on apparent ammonia nitrification rates (ApANRs). The curves were generated by conservatively fitting curves to the data collected on ApANRs in order to represent different nitrification rates with varying ALRs and

HLRs. The ammonia loading rate includes the ammonia concentration that is re-circulated and the hydraulic load includes the recycle.

According to the authors, the main difference between these curves and EPA design curves is that the required media surface area is dictated by the loading criteria (ALR and HLR) while with the EPA curves, it is dictated by the effluent quality regardless of the influent loading conditions. Therefore, their proposed curves are able to better depict the effect that the loading conditions have on the substrate removal efficiency in NTFs.

Nevertheless, the conditions under which the design curves are applicable are the same as for the application of EPA curves (vertical-flow plastic media of  $88.6 \text{ m}^2/\text{m}^3$  media specific density, height of 6.55 m, organic  $\text{COD}_5 < 30 \text{ mg/L}$  and  $\text{SS} < 30 \text{ mg/L}$ ). The design curves are also only limited to a temperature range of  $10 - 14^\circ\text{C}$ . The writers caution their use under temperatures less than  $10^\circ\text{C}$ , hydraulic rates  $> 4.8 \text{ m/hr}$  and media depths less than 6.55m without adequate experimental testing.

The curves developed by Gullicks and Cleasby (1986) are meant to be a simple conservative design application tool for the design of NTFs. The manner in which the curves can be applied in design is described as follows. The weight of ammonia that is loaded on the tower can be calculated from resident information while the effluent ammonia concentration is determined by effluent quality requirements. Approximate ALR and HLR values can be plotted on the design curves in order to determine the ANR and since the media specific density is known ( $88.6 \text{ m}^2/\text{m}^3$ ); the height of the TF can be calculated. Through a procedure of trial and error, a media height of 6.55 m is obtained by varying the hydraulic loading rate.

Evans *et al.* (2004) investigated the validity of the design curves developed by Gullicks and Cleasby (1986) by collecting experimental data from the same NTF that was used by the authors. The data collected during the Evans *et al.* (2004) investigation was found not to match the predicted trickling filter performance predicted by Gullicks and Cleasby (1986). The disparities were attributed to the intended conservative nature of the curves or factors that have not been accounted for or fundamental flaws in the curves. Nevertheless, Evans *et al.* (2004) recommended that sampling ports should be installed along the TF height such that the current model by Gullicks and Cleasby (1986) can be improved to a theoretical model.

Parker *et al.* (1989) concluded from their investigations that without the internal reaction rates, there is no firm basis for the assumption that reaction rates are uniform with depth. Excluding the internal rates in empirical design curves makes the translation of measured rates to different design conditions uncertain. Hence, it is essential to have fundamentally based design curves that can be applied to different site conditions with more accuracy and certainty.

## 1.1.2 THEORETICAL NITRIFYING TRICKLING FILTER MODEL

Gujer and Boller (1985a) presented a theoretical model of the NTF biofilm. The basis of this theoretical study was to provide a tool, which would give insight into the internal mechanisms of NTFs. The following assumptions were made in order to derive the equations for biofilm performance:

1. Within the biofilm, transport of chemical species may be described by molecular diffusion according to Fick's first law in one dimension only.
2. The biofilm is homogeneous with regard to biofilm density and operates at steady state
3. The biofilm is 'deep' i.e. at least one chemical species (limiting substrate) is required by the organisms disappears in the depth of the biofilm.
4. Single organisms are subject to Monod growth kinetics
5. Only one species is present
6. Mass transfer resistance between water and biofilm is negligible.

These assumptions are in agreement with the research that has been done on fixed biofilm models. Gujer and Boller (1985a) postulated a fundamentally based equation that determines the amount of ammonia that is used up in the biofilm. The equation was developed by performing mass balances of the dissolved species around a differential element of the biofilm.

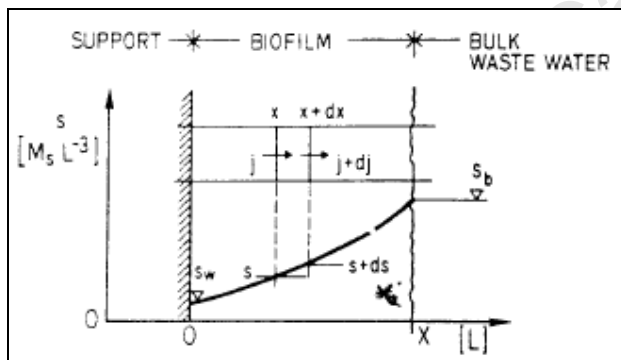

**Figure A1: Definition of terms in a differential volume element of biofilm**

SOURCE: Gujer and Boller (1985a)

$$j_b = [2D' \cdot \mu_{\max} \cdot \gamma \cdot Y]^{0.5} [s_b - s_w - K_s \cdot \ln(s_b + K_s / (s_w + K_s))]^{0.5} \quad (1)$$

Where;

$j_b$  = flux of substrate from bulk to biofilm [ $M_s L^{-2} t^{-1}$ ]

$D'$  = molecular diffusion within the biofilm [ $L^2 t^{-1}$ ]

$\gamma$  = density of active biomass within biofilm [ $M_x L^{-3}$ ]

$Y$  = Yield coefficient [ $M_x M^{-1}$ ]

$s_b$  = substrate concentration in bulk liquid wastewater [ $M_s L^{-3}$ ]

$s_w$  = substrate concentration in bulk liquid wastewater at the wall [ $M_s L^{-3}$ ]

$K_s$  = Monod saturation constant [ $M_s L^{-3}$ ]

The equation assumes a constant molecular diffusion with depth and takes into account Monod growth kinetics. They also developed another equation that estimates the  $s_w$  (see Figure A1) the value of which is generally not always known.

$$D_i'(s_{i,b} - s_{i,w})/v_i = D_i's_{i,b}/v_i \quad (2)$$

Where;

$D_i$  = molecular diffusion in pure water [ $L^2t^{-1}$ ]

$s_{i,b}$  = bulk ammonia concentration [ $M_sL^{-3}$ ]

$s_{i,w}$  = ammonia concentration at the wall [ $M_sL^{-3}$ ]

$v_i$  = stoichiometric coefficient of species 'i' (ammonia)

Note that subscripts 'i' in the equation refers to the limiting substrate

Equations 1 and 2 form the basis of the subsequent equations that quantify the performance of the nitrifying biofilm.

Gujer and Boller (1985a) have also derived equations that quantify actual ammonia nitrification rates (AcANRs) at specific depths along the nitrifying tower using samples collected along the depth to determine the experimental actual nitrification rates. Their data revealed that nitrification rates are temperature and pH dependent and that the diffusivity of oxygen and ammonia affects the nitrifying capacity of the biofilm.

They have assumed that the biofilm kinetic growth rate is a first order rate with respect to the ammonia concentration in the bulk liquid available for sequestration. In order for maximum nitrification rates to be achieved, the operating conditions have to oxygen-limited with effluent ammonia concentrations > 5 mgN/L.

The penetration depth for oxygen (for zero order kinetic rates, effluent ammonia concentrations > 5 mgN/L) can be calculated by the following equation;

$$\beta * T = 2 * D'_{O_2} * s^{\min}_{O_2,b} / (4.33 * j_{N,max}) \quad (3)$$

Where;

$\beta$  = fraction of the total biofilm depth L penetrated with oxygen

$D'_{O_2}$  = molecular diffusion coefficient of oxygen within the biofilm [ $L^2 t^{-1}$ ]

$s^{\min}_{O_2,b}$  = minimum bulk liquid oxygen concentration [ $M_sL^{-3}$ ]

$j_{N,max}$  = the maximum nitrifying capacity of the biofilm at steady state [ $M_sL^{-2}t^{-1}$ ]

Multiplying  $j_{N,max}$  by 4.33 gives the theoretical equivalent oxygen mass of the maximum ammonia nitrified at steady state. The solution to this equation gives the depth of the biofilm that is penetrated by oxygen. Boller and Gujer (1985a) found this depth to vary from 0.60 to 0.22 mm for a temperature range of 5° to 25° respectively. The calculated penetration depth was found to be significantly less than

the depth of a fully developed biofilm which justified their initial assumption, that external mass transfer resistance may be neglected. The increase of oxygen penetration depth with temperature indicates that deeper (thicker) biofilms are achieved at higher temperatures.

The following equation by Gujer and Boller (1985a) was derived from theoretical predictions of nitrification rates (equations 1 and 2). Equation 4 allows for the approximation of nitrification rates for a given bulk ammonia concentration

$$j_n(s, T) = j_{N, \max} \times e^{[0.044(T-10)]} \times \left\{ \frac{s_{N, b}}{N + s_{N, b}} \right\} \quad (4)$$

Where;

T = temperature °C

N = saturation parameter for substrate limitation [ $M_N L^{-3}$ ]

$j_{N, \max}$  = the maximum nitrifying capacity of the biofilm at steady state ( $s = \infty$  and  $T = 10^\circ C$ ) [ $M_N L^{-2} t^{-1}$ ]

For a value of  $N = 1 \text{ g N/m}^3$ , according to Gujer and Boller (1985a), the deviation of the results obtained from the theoretical and approximation equations was found to be insignificant. The equation, however, does not account for Monod relationship or enzyme kinetics for substrate sequestration. In the experiments carried out by Gujer and Boller (1985a), the maximum nitrifying capacity of biofilm achieved was  $0.85 \text{ gN/m}^2\text{d}$  at a temperature of  $10^\circ C$ . Equation (4) has been calibrated for a temperature of  $10^\circ C$  but can be interpolated for other temperatures by using the Nernst-Einstein equation.

Gujer and Boller (1985a) hypothesised that the nitrification rates decrease with depth as a result of patchy biofilm development in the lower depths of the TF media. They have thus proposed a 'line fit' equation to be used in the design of tertiary NTFs.

$$j_N(z, T) = e^{(-kz)} \cdot j_N \quad (5)$$

Where;

$j_N$  = nitrification rate in the top layer of the trickling filter (where  $z=0$ ) using equation (4) [ $M_N L^{-2} t^{-1}$ ]

T = temperature °C

k = empirical parameter that describes the decrease of the nitrification rate with reactor depth [ $L^{-1}$ ]

z = depth coordinate for the reactor [L]

When  $k = 0$ , there is no decline in nitrification rates with depth and conversely, when  $k \neq 0$  there is a decline in nitrification rates with depth. Experiments carried out by Parker *et al.* (1995) indicated that for NTFs operated in two-stage, there is no discernible decline of nitrification rates with depth. However, they found a strong depth effect for single-stage operation and under such operating conditions, a value of  $k \neq 0$  would be used.

Integration of equation 5 gives the solution to the required media depth for maximum predicted AcANRs. The depth has been transformed to a 'depth parameter which is defined as;

$$Zz = s_N - s_{Ni} + N^* \ln (s_{N,i}/s_N) \quad (6)$$

Where;

$s_N$  = the bulk ammonia concentration at  $z = 0$

$s_{N,i}$  = the bulk ammonia concentration at  $z$

This depth parameter yields the following equations at boundary conditions;

$$k \neq 0 \quad Zz = a^* j_{N,max}(T)^* [1 - \exp(-kz)] / (k^* v_h) \quad (6.1)$$

$$k = 0 \quad Zz = z^* a^* j_{N,max}(T) / v_h \quad (6.2)$$

Where;

$v_h$  = the hydraulic loading rate [ $L T^{-1}$ ]

$a$  = the media specific density [ $L^2 L^{-3}$ ]

In order to account for hydraulic loading, Gujer and Boller (1985a) derived an equation that allows for the estimation of recirculation as a percentage of the influent flow on the NTF based on Figure A2.

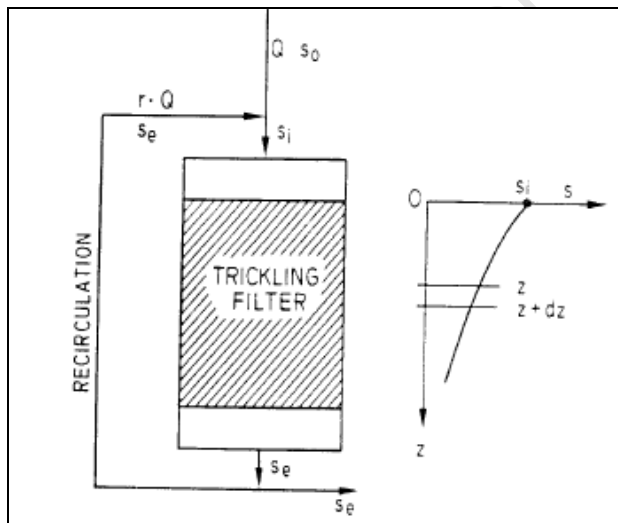

**Figure A2: Definition of recirculation in trickling filter**

SOURCE: Gujer and Boller (1989a)

$$r = (s_0 - s_i) / (s_i - s_e) \quad (7)$$

In many cases in the operation of NTFs, recirculation of TF effluent is required to achieve the optimum HLRs for maximum nitrification rates. This equation is a guideline on what extra pumping capacity will be required to obtain optimal hydraulic loading conditions. The theoretical model of nitrification in NTFs

by Boller and Gujer (1985a) favours decoupling of ALR and HLR and hence the effect that both of these parameters on AcANR can be determined separately.

A design example on the application of the Boller and Gujer (1989) a model equation from their paper is provided below:

Secondary effluent, containing a peak concentration of 20 g N/m<sup>3</sup> should be nitrified to obtain;

<2 g N/m<sup>3</sup> in winter (10°C)

<0.3 g N/m<sup>3</sup> in summer (20°C)

The following information is provided;

$a = 200\text{m}^2/\text{m}^3$

$v_h = 80\text{m}/\text{d}$

$j_{N,\text{max}} = 0.94\text{ g N}/\text{m}^2\text{d}$  at 10°C

$k = 0.11\text{m}^{-1}$

$N = 1\text{ g N}/\text{m}^3$

What is the required recirculation rate in single trickling filter?

**Table A1: Theoretical model design example**

	10°C	20°C	Units	Equation
Height	6	6	m	
$j_{N,\text{max}}$	0.94	1.46*	g Nm <sup>-2</sup> d <sup>-1</sup>	*Equation (5)
$s_N$ (at z=0)	20	20	g Nm <sup>-3</sup>	
$s_N$ (at z)	2	0.3	g Nm <sup>-3</sup>	
k	0.11	0.11	0.11	
$Z_z$ (k ≠ 0)	10.3	16.0	g Nm <sup>-3</sup>	Equation (6)
$s_N$ influent	10.7	12.6	g Nm <sup>-3</sup>	Equation (6.2)
$r$	1.07	0.6	-	Equation (7)

\*the maximum AcANR converted from the value obtained at 10 °C

The theoretical model by Boller and Gujer (1985a) can be used to determine the required media depths and recirculation ratio for maximum AcANRs. However, the model does not account for the effect that the media configuration has on nitrification rates. Parker *et al.* (1989) have found that the oxygen transfer efficiency of plastic media varies widely with media geometry. Hence, Parker *et al.* (1989) have modified equation (5) to account for the effect that media configuration has on nitrification rates.

$$J_{n,\text{max}}(T) = E^* j_{o2\text{max}}(T) / 4.33 \cdot S_N / (N + S_N) \cdot e^{-kz} \quad (8)$$

Where;

E = media effectiveness factor

$j_{o2\text{max}}(T)$  = maximum surface oxygen transfer rate for specific media design [gN/m<sup>2</sup>d]

N = saturation parameter for substrate limitation [M<sub>N</sub>L<sup>-3</sup>]

The model by Logan (1993) (LTF model) has been used to determine  $j_{o2max}$  in equation (8). The factor of 4.33 reflects the unit mass of oxygen consumption per unit mass of ammonia that is oxidized. The division by this number denotes the theoretical zero order nitrification rate in the NTF. The media effectiveness factor  $E$ , is a ratio of the experimental zero-order rate to the theoretical rate. It has been found to be usually less than 1.0 due to biofilm predation, heterotrophic activity, or poor media wetting (Parker *et al.*, 1997). The values of  $E$  and  $k$  can be determined from the reactions rates derived from the ammonia profiling (Parker *et al.*, 1997).

In addition to equation (8), Parker *et al.* (1997) have introduced a ratio  $E_{avg}$ . This is a ratio of the 'average' zero-order nitrification rates calculated at depths in the TF where the ammonia concentration is  $> 5\text{mgN/L}$  to the theoretical oxygen-limited  $AcANRs$ . This term provides an indication of the overall process performance. The average rates differ from the apparent rates by their exclusion of ammonia limited reactions occurring near the bottom of the tower. From their results, Parker *et al.* (1995) found the following variables to affect nitrification rates significantly; temperature, TSS concentration and HLR. The value for  $E_{avg}$  ranged from 0.37 to 0.75 in the results obtained by Parker *et al.* (1995). The decline in the value was due to the effect of one or more of the above mentioned variables.

Essentially, the difference between  $E$  and  $E_{avg}$  is that  $E$  accounts for the media efficiency in allowing for biofilm attachments hence the variables such biofilm predation, heterotrophic activity, or poor media wetting affect it.  $E$  is calculated by using equation (8). On the other hand,  $E_{avg}$  accounts for the factors that affect nitrification rates within the biofilm – such as loading conditions of TSS concentrations, temperature and hydraulic application as previously mentioned.

Parker *et al.* (1995) evaluated the combined effect of the variables that affect  $E_{avg}$  values by using multiple regression analysis. Equation (9) is the result of the multiple regression analysis. The confidence interval for the coefficient of the constant, temperature, TSS concentration and hydraulic loading rate are 75%, 95%, 95% and 95% respectively (Parker *et al.*, 1995)

$$E_{avg} = 0.114 + 0.0217*(Temp, ^\circ C) - 0.00841*(TSS, \text{mg TSS/L}) + 0.0838*(V_h, \text{m/h}) \quad (9)$$

Equation (9) shows that temperature has a modest effect on nitrification rates. Parker *et al.*, 1995 found the  $E_{avg}$  value to increase with an increase in HLRs or switching from single- to two- stage NTF operation. The influent TSS concentration was found to have a strong impact on nitrification rates on the cross-flow media that was investigated. Cross-flow media is more susceptible to blockages than vertical-flow media because it has more media interruptions per media surface area. It has been concluded by Parker *et al.* (1995) that each variable has a significant effect on nitrification rates. Equations (8) and (9) by Parker *et al.* (1989 and 1995) represent a design model that can be used to compare predicted and actual nitrification rates.

Evans *et al.* (2004) attempted to calibrate the empirical model by Gullicks and Cleasby (1990) and the theoretical model by Gujer and Boller (1986a). Their paper was on the research of the nitrifying capabilities of NTFs and combined carbon and ammonia removing trickling filters. They also aimed to

define the variables that affect nitrification rates. They found that the empirical model poorly fit their collected data and that the theoretically based model could not be calibrated well with apparent ammonia removal rates. Hence, a best-fit equation was generated from a statistical regression in their investigation for the design curves by Gullicks and Cleasby (1990) and a non-linear regression function to calibrate the Gujer and Boller (1986a) model. However, they suggested that a customized calibration of the theoretical model would yield better predictions. Evans *et al.* (2004) used the following variables, influent ammonia concentration, HLR, recirculation and temperature as ammonia nitrification predictors in both models. Statistical analyses revealed that 64% of the variability in the ammonia nitrification could not be explained by the defined predictors. The authors concluded that either additional variables need to be considered or the relationship used is not accurate.

The fundamental models provided by Parker *et al.* (1989 and 1995) and Gujer and Boller (1986a) allow for extrapolation to other NTFs operated under different conditions, which could not be previously done with the empirical models. However, in order to use the Boller and Gujer (1986a) model, maximum actual nitrification rates have to be converted to nitrification rates at 10°C. There is no certainty in the accuracy of these converted actual nitrification rates. The theoretical NTF model by Gujer and Boller (1986a) is intended as a guideline tool for design as the model is yet to be verified by experimental data. Investigations are also required to improve and simplify the use of these models.

<b>1. NITRIFYING TRICKLING FILTER MODELS</b>	<b>1</b>
1.1.1    EMPIRICAL NITRIFYING TRICKLING FILTER MODELS	1
1.1.2    THEORETICAL NITRIFYING TRICKLING FILTER MODEL	3
Figure A1: Definition of terms in a differential volume element of biofilm	3
Figure A2: Definition of recirculation in trickling filter	6
Table A1: Theoretical model design example	7

University of Cape Town

<b>TABLE OF CONTENTS</b>	<b>Page</b>
--------------------------	-------------

## **APPENDIX A: LITERATURE REVIEW – NITRIFYING TRICKLING FILTER MODELS**

<b>1. NITRIFYING TRICKLING FILTER MODELS</b>	<b>A-1</b>
1.1.1 Empirical nitrifying trickling filter models	A-2
1.1.2 Theoretical nitrifying trickling filter model	A-3

<b>LIST OF FIGURES AND TABLES</b>	<b>Page</b>
-----------------------------------	-------------

Figure A1: Definition of terms in a differential volume element of biofilm	A-3
Figure A2: Definition of recirculation in trickling filter	A-6
Table A1: Theoretical model design example	A-7

University of Cape Town

**APPENDIX B:  
SUMMARY OF SITE DIARIES**

University of Cape Town

## SITE VISIT

11-12 APRIL 2007

### SITE INVENTORY

- It was drizzling upon arrival. It rained the night of the 11th of April
- All pumps are still working
- East and North face fans are still out of order
- South face seems to have the worst leaks
- Sprinklers are not operating at optimum

### LAGOON

- The unaerated lagoon is very green. The outlet from the lagoon to the Olifants River has been closed

### NITRIFYING TOWER

- The effluent sump wastewater is green
- There is a significant amount of solids on the surface of the effluent in the sump
- The tower samples had a significant presence of filter flies. The North face in particular showed the most presence. Flies were particularly present on the outside of the tower near the north face

### FINAL EFFLUENT POND

- There was no outflow from the final effluent pond
- The pond was greenish in colour too.

Spoke to Koos Kellerman about the replacement of the fans. Currently there is no indication of the length of the waiting period for the replacement of the fans.

### SUSPENDED SOLIDS NTF SAMPLE ANALYSIS

Peter microscopically analysed a sample for the E2 sampling port for microorganisms.

He found the following

- A significant presence of filter fly worms which are indicative of the presence of filter fly larvae
- A significant amount of suspended solids that are a result of endogenous residue probably from the degradation of filter flies that may be trapped in the TF and the skin shedding of the filter fly worms.

He pointed out the filter fly larvae require a lot less oxygen for survival in comparison to the biofilm. Thus their prevalence may increase at low oxygen concentrations and high hydraulic loading rates

- A pesticide could be used to get rid of the flies to reduce the chances of further laying of eggs. In choosing this pesticide care must be taken in ensuring that the chosen pesticide does not produce significant residue

### SITE INSPECTION

- All sprinklers seem to be working well
- Two pumps have been in operation since last visit
- All fans are working, but west face fan is making a funny noise
- Effluent sump is full, must have been raining recently
- South and east walls have a lot of algae growing on them
- Tower is leaking excessively on the lower regions, about 0.5m from the floor
- Pump 1 to be taken back to Cape Town to check for the mechanical fault
- The first aerator in the lagoon has not been in use for about 3 weeks. They are waiting for parts from Cape Town to fix it.
- There is an unpleasant odour emanating from the lagoon

### FLOW MEASUREMENT

Due to time constraints and bad weather, only two orifice plates were checked, namely; 0.075mm and 0.063 mm diameter. All of the flow measurements were done with the sprinklers on.

Pressure gauges were installed. The piping will not be efficient in measuring the pressure across the orifice plate because an algal growth has lined the tubing therefore making it difficult to read the water level. The ultrasonic flow meter was also installed as means of verifying the flow measurement obtained using the orifice plate.

During flow measurement P3 over heated and switched itself off. This is after it had been discovered that the spray pattern with P2, for a typical recirculation sprinkler, covers a bigger area in comparison to when P3 is in operation. This is corroborated by the differences in pressure readings when both these pumps are running alone. P3 generates a pressure that is approximately 20% less than P3. This pump needs to be checked for electrical and mechanical faults.

Theoretically, the flow is meant to be double that of one pump if two pumps are connected in parallel and the pressure is meant to stay more or less the same.

The pressure with two pumps is roughly 10% less than when one pump is running. However, the total flow generated by two pumps operation is less than when one pump is in operation. This means that a lot of energy is lost in the manifold configuration, thus resulting in a reduced total flow when more than one pump is in operation. Table 1 summarises the flow measurement results.

Table 1: Flow measurement using an orifice plate and verification of the obtained results

Pump combination	Orifice plate diameter	FLOW MEASUREMENT METHOD		
		Orifice plate	Bucket & stopwatch	Ultrasonic flow meter
P1 & P2	0.075mm	6675	5000	
P2	0.075mm	9861		9732
P3	0.075mm	8820		6726
P2 & P3	0.075mm	6236		8363
P2	0.063mm	5696		8720
P3	0.063mm	5094		6250
P2 & P3	0.063mm	3602		7530

University of Cape Town

## SITE VISIT

28–29 AUGUST 2007

### SITE INVENTORY

- The recirculation pump was not pumping any wastewater on arrival
- Influent sprinklers seemed to be working relatively well
- All fans operational

### NITRIFYING TOWER

- No scum on the water surface of the effluent sump
- Lots of flies on the outside of the upper regions of the West face

The new recirculation pump needs to be fixed hence it was switched off and the Badu pump was switched on 28/08/07. Mr Visser was too busy to clarify as why the new pump was broken on the day of arrival. It turns out that the influent NTF pump from the lagoon was temporarily out of order for a period that no one seems to be able to confirm. Hence, the effluent sump was empty. The recirculation pump continued pumping air for a period that yet again cannot be confirmed.

Mr Visser cannot confirm when the pump will be fixed. One Badu pump in operation does not give the desired recirculation ratio of at least 1:1. Nevertheless, he did promise to attend to it as soon as possible. The option of purchasing another pump like the new one will take long due to the paper work that municipality requires for purchases over R4000. It is at this point doubtful if further investments in the project can be justified when expensive equipment is broken because of negligence. It is costly to arrange the trips to Citrusdal and if there is no guarantee that the required operating conditions will be maintained as long as possible without any upsets due to negligence then it is not worth the effort.

In 5 weeks, Bless only collected 5 days of samples. This is insufficient data to assess with confidence the performance of the nitrification tower.

**SITE VISIT: SITE INSPECTION****16/FEB/06**

The purpose of this visit was to collect samples in order to analyse any changes in the nitrification rates since the installation of the recirculation system in 06 October 2005. The nitrification tower was also to be assessed for any changes that would be necessary to insure a hassle-free operation of the recirculation system

**NITRIFYING TOWER ASSESSMENT**

North-face fan is not working. According to Bles, Mr Kellerman is expected to come soon and repair it. The tower is leaking excessively. According to the workers this has been going on for about 3weeks prior to the visit.

The leakages occur mainly in the lower region of the tower, about 500mm from the ground. The leakages are worse on the north and south faces in comparison to the east and west faces of the tower.

A remedial measure to remove the water that collects around the tower has been to bury a pipe which will remove water from the n-w corner of the tower and direct it to the influent raw wastewater channel. However nothing has been done about the water that is collecting on the south face of the tower. There has been no problem with the pumps. The pump filters are being cleaned every second day. Currently, two pumps are in operation.

All sprinklers are working efficiently. Both the recirculation and influent flow sprinklers are being cleaned every second day.

The effluent in the sump is not as dark in colour as it has been in the past. There is no foam at the top and the water level in the sump is quite high.

The operation of the recirculation system is satisfactory. There will be no operational changes required.

**SAMPLE COLLECTION**

Samples were collected at the following locations at the plant:

Influent channel

Effluent Lagoon

Influent NT

Effluent NT  
 Final Effluent (of the treatment plant)  
 Profile samples on the tower

**QUALITATIVE EVALUATION OF NTF PORT SAMPLES**

A table has been devised in order to qualitatively evaluate the NTF operational performance.

**METHOD OF EVALUATION**

The wetting rate evaluated by the time it takes for the sample to devise to collect approximately 50ml of sample. A maximum time of one minute is set to collect 50ml. All samples that are collect with a minute will be denoted with an asterisk (\*), which indicates a good wetting rate. Any samples that take longer will be denoted with two asterisks, which indicate a poor wetting rate.

The amount of predator present in the collected sample will be evaluated on a scale of 0 to 3. Where 0 denotes no presence of predators, 1 is for the least presence of the respective predator and 3 the most. Note the first sample core is at the top of the tower.

**Prevailing external conditions**

Ambient temperature: 31.5°C  
 There has been no rain for a long period prior to the visit

*North and South face evaluation 16/02/06*

			Predators						Predators		
NTF FACE	Sample core	Wetting rate	Snails	Worms	Flies	NTF FACE	Sample core	Wetting rate	Snails	Worms	Flies
NORTH	N 1	*	0	0	0	SOUTH	S 1	*	0	0	0
	N 2	*	0	0	0		S 2	*	0	0	0
	N 3	*	0	2	0		S 3	*	0	0	0
	N 4	**	0	2	0		S 4	*	0	0	0

In general, all profile samples had a high content of fine green particles. There was also a significant amount of small insect fragments. The worm content in lower region of the North Face was quite significant. The flow rate in the last port at the bottom of the north face of the tower was very poor.

There was an insignificant presence of filter flies in the samples collected. Although, upon inspection, it has been found that north and south faces are leaking the most, the wetting rate was found to be good.

*West and East face evaluation 16/02/06*

			Predators						Predators		
NTF FACE	Sample core	Wetting rate	Snails	Worms	Flies	NTF FACE	Sample core	Wetting rate	Snails	Worms	Flies
WEST	W 1	*	0	0	0	EAST	E 1	**	0	0	2
	W 2	*	0	0	0		E 2	**	0	0	0
	W 3	*	0	0	0		E 3	**	0	0	0
	W 4	*	0	0	0		E 4	*	0	0	0

There was a significantly greater presence of insect fragments in the samples collected on the West and East faces. The wetting rate on the East face is generally very poor. There was very little sample collected in the third port on this face. However the fourth port, which is directly below the third port, had a good sample collection thus indicating a good wetting rate. There were bits of plastic media collected from the third port. Thus the reason for such little flow through the third port could be due to the plastic media which could have collapsed in the port and consequently constricting flow. Alternatively, another reason for this could be that the last row of sprinklers, nearest to East edge of the tower, are located a bit far from the edge and their effective spray does not cover a large enough area. This could also be the reason why the first sample port has such a significant fly content. The same sprinkler arrangement is true for the west face. However, even though the wetting rate in the first two ports of the west face was poor, 50ml of sample was eventually collected. Conversely, very little sample was collected on the East face. Thus the poor wetting rate on the East face must be as a result of blocked irregular flow pattern. The reason for the blocked media cannot be ascertained at this stage.

**ASSESSMENT OF THE PERFORMANCE OF TOWER**

A qualitative comparison on the performance of the tower was made on the results that were obtained on 15/09/05 prior to the installation of the recirculation system.

*Assessment 15/09/05*

*Assessment 16/02/06*

			Predators						Predators		
NTF FACE	Sample core	Wetting rate	Snails	Worms	Flies	NTF FACE	Sample core	Wetting rate	Snails	Worms	Flies
NORTH	N 1	**	0	0	3	NORTH	N1	*	0	0	0
	N 2	*	0	0	2		N2	*	0	0	0
	N 3	**	0	0	3		N3	*	0	2	0
	N 4	**	0	0	3		N 4	*	0	2	0

The wetting rate on the north face has improved significantly. There are currently no filter flies present.

*Assessment 15/09/05*

*Assessment 16/02/06*

			Predators						Predators		
NTF FACE	Sample core	Wetting rate	Snails	Worms	Flies	NTF FACE	Sample core	Wetting rate	Snails	Worms	Flies
SOUTH	S 1	*	0	0	1	SOUTH	S 1	*	0	0	0
	S 2	*	0	0	1		S 2	*	0	0	0
	S 3	*	0	0	1		S 3	*	0	0	0
	S 4	*	0	0	1		S 4	*	0	0	0

The wetting rate on the south has continued to be good. There is currently no presence of filter flies.

*Assessment 15/09/05*

*Assessment 16/02/06*

			Predators						Predators		
NTF FACE	Sample core	Wetting rate	Snails	Worms	Flies	NTF FACE	Sample core	Wetting rate	Snails	Worms	Flies
WEST	W 1	*	0	0	1	WEST	W 1	*	0	0	0
	W 2	*	0	0	1		W 2	*	0	0	0
	W 3	*	0	1	1		W 3	*	0	0	0
	W 4	*	0	0	1		W 4	*	0	0	0

The wetting rate on the west face has also remained good. There is currently no presence of filter flies.

*Assessment 15/09/05*

*Assessment 16/02/06*

			Predators						Predators		
NTF FACE	Sample core	Wetting rate	Snails	Worms	Flies	NTF FACE	Sample core	Wetting rate	Snails	Worms	Flies
EAST	E 1	**	0	0	3	EAST	E 1	**	0	0	2
	E 2	**	0	0	2		E 2	**	0	0	0
	E 3	**	0	0	3		E 3	**	0	0	0
	E 4	**	0	0	3		E 4	*	0	0	0

The wetting rate along the East face has persisted to be poor. Although the fly content has decreased considerably, there is still a significant fly presence at the top to East face.

Since the installation of the recirculation system on 06 October 2006, the wetting rate of the tower has improved. There has also been a very significant reduction in the presence of filter flies in the tower. The East face of the tower is the only one that has not improved in wetting rate. However, the conditions that now prevail along this face of the tower are not conducive to the development of filter flies. The fly content on this face has been significantly reduced, excluding the first part of the face.

**ANALYSIS**

*Wastewater characterisation 16/02/06*

Parameter	Unit	Influent wastewater (unfiltered)	Influent wastewater (filtered)	Lagoon effluent (filtered)	NTF influent (filtered)	NTF effluent (filtered)	Final effluent (filtered)	Goal
COD	mg/L	1374	343	112	92	92	69	<75
NH <sup>+</sup> <sub>4</sub>	mg/L		60	-	39	3	22	<3
NO <sup>-</sup> <sub>3</sub>	mg/L	-	-	-	5	19	4	<15
PO <sup>-</sup> <sub>4</sub> <sup>3</sup>	mg/L	-	8	9	10	10	9	<10

The COD concentration in the effluent is below the maximum allowable concentration of 75mg COD/L. The plant is thus efficiently removing the organics from the wastewater.

The ammonium removal of the nitrifying tower has improved significantly. Currently the tower is removing 85% of the influent ammonium concentration. This has considerably improved from an average ammonium removal of 31% achieved from the period of 01/07/05 to 05/10/05. However ammonium concentration increases noticeably in the effluent wastewater. This could be due to the presence of organic, in the final effluent ponds, which are releasing ammonium to the water. It is

suggested the plants be cleaned because they make it seem like that plant is not efficiently removing ammonium. The final ammonium concentration in the effluent of the tower ( $3 \text{ NH}_4\text{mg/l}$ ) is at the upper limit of the allowable ammonium concentration in the effluent ( $<3 \text{ NH}_4\text{mg/l}$ ). This is the best ammonium removal performance of the tower. This confirms that an increase in the wetting rate improves ammonium removal in the nitrifying tower.

The phosphates are below the allowable concentration of  $10 \text{ PO}_4^{3-}\text{mg/l}$ . The influent phosphate concentration was  $35.5 \text{ mg PO}_4^{3-}\text{/l}$  on 01/07/05. There has been a drastic reduction in the influent phosphate concentration to  $8 \text{ mg PO}_4^{3-}\text{/l}$ . Samples need to be collected over an extended period to determine the trend of the influent phosphate concentration.

The nitrate concentration ( $19 \text{ NO}_3 \text{ mg/l}$ ) in the effluent nitrifying tower has decreased from  $21 \text{ NO}_3 \text{ mg/l}$  (01/07/05). The influent ammonium concentration which was measured during that time ( $67 \text{ NH}_4\text{mg/l}$ ) is roughly same as the one measured on 16/02/06. However on 01/07/05 the tower was only removing 32% of the influent ammonium in the nitrifying tower.

The performance of the tower has improved significantly since the installation of the recirculation system. The recirculation system has resulted in an increase in ammonium removal from 31% to 85%. The removal percentage exceeds the intended aim of 80%.

## PERFORMANCE OF THE NITRIFYING TOWER

The following graphs depict the performance of the tower with regards to the amount of ammonium removed along the four samples ports on each tower face.

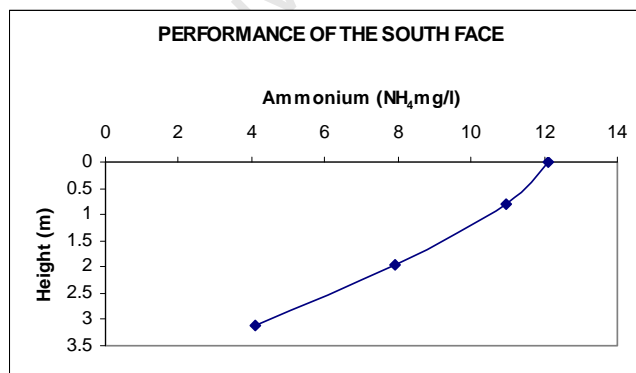

The south face of the nitrifying tower is removing more ammonium in the middle to lower regions of the tower. According to literature the highest removal of ammonium occurs in the upper regions of the tower. However, the performance of this face is still satisfactory regardless of the excessive leaking.

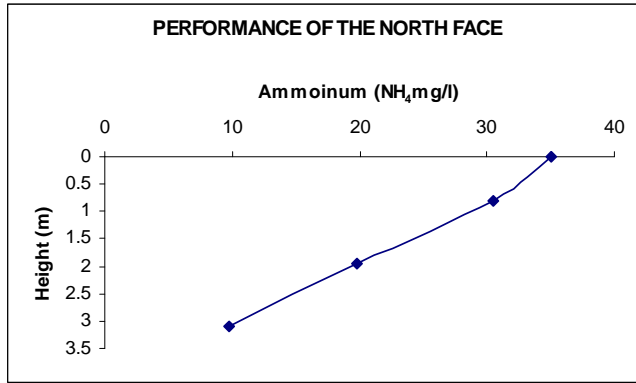

The north face is exposed to higher concentrations of ammonium in comparison to all the other faces. This face also removes the most ammonium in spite of the fan that was found to not be working when samples were taken and the excessive leaking that takes place at the bottom of this face.

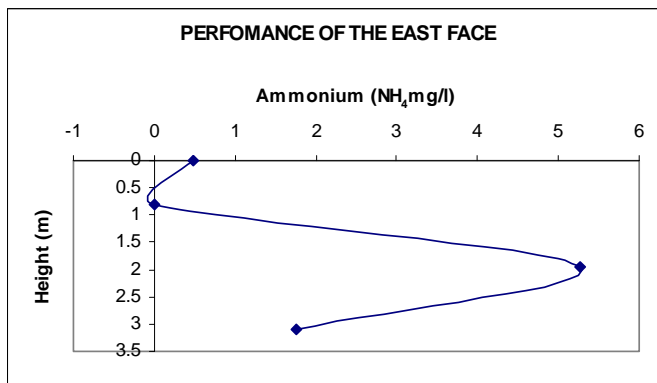

The east face has the poorest performance of all faces. There was no sample collected from the second port which accounts for the irregular shape of the graph. There was also very little sample collected from the last port.

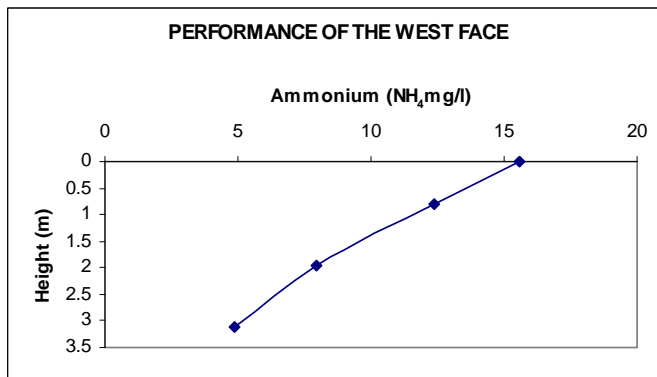

The west face comes second to the north face in terms of exposure to the ammonium concentration. The face performs well with most of the ammonium removed in the upper region of the tower.



In general the tower is performing well. Most of the ammonium is removed in the upper regions of the tower i.e. the region between the top of the medium exposed to air and the first sample port. This is expected because this region has the highest ammonium concentration and oxygen exposure. The poor performance of the east face at the second sample port has had a significant affect on the ammonium removal of the tower.

It is now imperative to install a flow measurement device in order to determine the optimum wetting rate to achieve maximum nitrification.

## SITE VISIT

06 - 08 FEBRUARY 2007

### SITE INSPECTION

- South face fan is still out of order
- The leaking around the tower is not so bad
- All other fans are in working order
- The worst leaks are on the South face in the lower regions of the tower where there is no media
- All sprinklers are in working order
- The wastewater in all units has a green colour. According to Bles this is usually the case during the summer months.

### LAGOON

- In the mornings there were bubbles at the surface of the unaerated lagoon zone.
- The water level in the lagoon is quite low, assumption that a significant amount of water is lost due to evaporation

### FINAL EFFLUENT POND

- No out flow from the pond
- A lot of water also lost to evaporation. Water level decrease by over 300mm from 7am to 3pm (the surface area of the pond is 500m<sup>2</sup>) Thus over 15m<sup>3</sup> of wastewater evaporates during the summer months resulting in no outflow to the Olifants River

### NITRIFYING TRICKLING FILTER

- The flow rate along the east face has improved considerably
- There was no presence of filter flies in the profile samples collected
- The wetting rate in most of the profile sampling ports was good

### SAMPLING

I have organized for samples to be couriered on a weekly basis from Citrusdal. It takes two days for the samples to arrive in Cape Town. Thus to avoid further growth in the samples, Bles has been instructed to do the following:

1. Preserve the samples immediately when he draws them
2. To take two samples and filter the other with a 0.45 µm whatman filter paper
3. To place samples in the freezer until they are to be collected
4. No samples are to be taken on the day that they are meant to be couriered

All samples are preserved for obvious reasons. To prevent any growth that might occur during transportation, one sample is filtered to remove as much solids as possible. The samples are frozen to further prohibit any growth that could take place.

*Assessment 07/02/07*

			Predators						Predators		
NTF FACE	Sample core	Wetting rate	Snails	Worms	Flies	NTF FACE	Sample core	Wetting rate	Snails	Worms	Flies
NORTH	N 1	*	0	0	0	SOUTH	S 1	*	0	0	0
	N 2	*	0	0	0		S 2	*	0	0	0
	N 3	*	0	1	0		S 3	*	0	0	0
	N 4	***	0	1	0		S 4	*	0	0	0

*Assessment 07/02/07*

			Predators						Predators		
NTF FACE	Sample core	Wetting rate	Snails	Worms	Flies	NTF FACE	Sample core	Wetting rate	Snails	Worms	Flies
WEST	W 1	**	0	1	0	EAST	E 1	***	0	0	0
	W 2	*	0	0	0		E 2	**	0	0	0
	W 3	*	0	0	0		E 3	*	0	0	0
	W 4	*	0	0	0		E 4	*	0	0	0

The wetting rate in all profile sampling ports was good. The wetting on the South face was extremely good. The samples collected along this face were also relatively clear. The rest of the samples had a high turbidity. [The solids seemed to be of small fragments of an organisms external ....?](#)

## SITE VISIT

26 JULY 2006

### SITE INSPECTION

- The north face fan has been fixed
- Tower is still leaking
- Pumps 1 and 3 have been out of order for the last 3 weeks
- Pump 1 is due to a mechanical fault
- Pump 3 is due to an electrical fault
- Only pump 2 has been in operation
- No spray from recirculation sprinklers, one pump is insufficient

### OBSERVATIONS ON OPERATION UNITS

- Although the recirculation system has not been operating optimally, there was not sign of predation.
- The tower profile samples have a lot of solid matter. *This could be due to sloughing????*
- There was an outflow from the final effluent pond
- Scum layer in the effluent lagoon. The scum layer is a result of the foam that develops in the aerated zone.
- Foam in the aerated zone. Foam could be due to some bacteria that is present in the wastewater or a product of the degradation of some compound.

### REMEDIAL ACTIONS

- Have all sprinkler nozzles removed whilst there is only one pump in operation.
- Upon a follow up with Boet Visser and Koos Kellerman, the one pump with an electrical fault has been fixed and is in operation as of 01 August 2006. The mechanical fault was due to an object that got lodged in the impeller. I will take it back to Cape Town on my next visit.

### Samples analysis in brief

The tower has removed very little ammonia since the last visit. Of the samples that Bles took, the ammonia concentration decreases by 50% when it reaches the NT. According to the analysis of the samples he took, this means that the poor performance of the tower could also be attributed to the insufficient ammonia loading. His sampling techniques could be in question. Verify.

## SITE VISIT

26 JULY 2006

### SITE INSPECTION

- All sprinklers working well
- All 3 Badu pumps have been replaced with a 1.1kw pump. The north face fan has been fixed
- Tower is still leaking
- Pumps 1 and 3 have been out of order for the last 3 weeks
- Pump 1 is due to a mechanical fault
- Pump 3 is due to an electrical fault
- Only pump 2 has been in operation
- No spray from recirculation sprinklers, one pump is insufficient

### OBSERVATIONS ON OPERATION UNITS

- Although the recirculation system has not been operating optimally, there was not sign of predation.
- The tower profile samples have a lot of solid matter. *This could be due to sloughing????*
- There was an outflow from the final effluent pond
- Scum layer in the effluent lagoon. The scum layer is a result of the foam that develops in the aerated zone.
- Foam in the aerated zone. Foam could be due to some bacteria that is present in the wastewater or a product of the degradation of some compound.

### REMEDIAL ACTIONS

- Have all sprinkler nozzles removed whilst there is only one pump in operation.
- Upon a follow up with Boet Visser and Koos Kellerman, the one pump with an electrical fault has been fixed and is in operation as of 01 August 2006. The mechanical fault was due to an object that got lodged in the impeller. I will take it back to Cape Town on my next visit.

### Samples analysis in brief

The tower has removed very little ammonia since the last visit. Of the samples that Bles took, the ammonia concentration decreases by 50% when it reaches the NT. According to the analysis of the samples he took, this means that the poor performance of the tower could also be attributed to the insufficient ammonia loading. His sampling techniques could be in question. Verify.

## SITE VISIT

14 JUNE 2006

### SITE INSPECTION

- North face fan has been removed for fixing
- It had previously rained hard for two days prior to the visit. The lagoon and effluent NT sump were covered with foam.
- There emergency flow from the lagoon into the Olifants River was relatively strong. The pipe was flowing at about a 1/5 of its capacity.
- There was an out flow from the final finishing pond into the River.
- The recirculation rate is being run with 21/2 pumps in operation.
- The truck arrived with the sewerage from the surrounding farms that use septic tanks and informal settlement that is still using the bucket system. This takes place at the middle of every month.

### OBSERVATIONS ON THE OPERATION UNITS

- Outflow of untreated water from the emergency outflow from the lagoon into the River
- There was an outflow from the final finishing effluent pond into the River.
- The tower is leaking excessively along the lower region of the wall i.e. below the position of the blower fans.
- The East face wall is relatively dry in comparison to the other tower faces.

### FLOW MEASUREMENT

Previously the recirculation flow rate was measured using a bucket and stopwatch method. The value obtained was 5 m<sup>3</sup>/hr. This was much lower than the predicted value from calculations of about 60 m<sup>3</sup>/hr. The head loss coefficient assumed for the sprinklers was an estimated value that could be questionable.

During this site visit, the bucket and stop watch method was carried out again but this time the flow was tested without the nozzles. A flow rate of 20 m<sup>3</sup>/hr was obtained. This verified that the head loss coefficient assumed for the nozzles was indeed grossly under-estimated.

It has then been decided to devise a system that produces a lower head loss. The idea is to remove the nozzles and allow the jet stream to fall on some contraption that will disperse the water onto the media.

## **SAMPLING**

Currently samples are collected on average once a month. This has proved to provide an insufficient data set in order to realistically quantify the performance of the data. Thus Bles has been trained to collect samples during the intermediate periods of the site visits.

Composite samples are collected at the influent to the treatment plant, the influent and the effluent to the NTF. These composite samples are made up the samples that are collected 3 times a day. They preserved and refrigerated until they are collect. A sample will be preserved for maximum of three weeks before it can be analysed.

University of Cape Town

## SITE VISIT

24 – 25 JULY 2007

### SITE INVENTORY

Two recirculation pumps are out of order since 30/05/07. Hence, one pump has been in operation. The BHS pump that is left has been put on standby. Currently a EBARA CMD/A 150m 1.1 kW pump is in operation. This pump yields a flow rate of 31 m<sup>3</sup>/hr under the current operating conditions. This results in a hydraulic loading rate of 3.5m/hr.

There has been a lot of rain in the recent past days. It rained quite heavily on 24 July.

### LAGOON

There appears not to be a significant presence of algae in the oxidation pond anymore. The prevalence of bubbles on the surface of the unaerated zone is not so significant anymore. There is foam on the water surface in the mornings.

### NITRIFYING TOWER

- The sump appears to have less algae
- There is a lot worms floating on the surface water of the effluent sump
- The tower is still leaking as badly
- There is foam on the water surfaces that surround the tower due to the leaking especially in the mornings.

The feed and recirculation flows were measured to be 40 m<sup>3</sup>/hr and 31 m<sup>3</sup>/hr respectively. The recirculation flow increases the hydraulic loading rate by 78%. This results in a hydraulic loading rate of 3.5 m/hr which is still sufficient to provide for adequate wetting conditions.

Boet has replaced the BHS pumps with a a EBARA CMD/A 150m 1.1 kW. This is adequate to achieve the required hydraulic loading rate and also does not require any alterations to the manifold.

### MICROSCOPIC ANALYSIS OF NTF PROFILE SAMPLES

#### E2

Medium murkiness. The flow rate was poor and there was a significant presence of worms.

#### E2 analysis

True floc present but not as much as in E4. *Phycoda seta* also present. No *phacus* but some *Aspidisca* (crawling ciliate) was observed.

#### E4

The flow this face is generally very good. There appeared to be no presence of any of the usual predators. The sample was highly turbid.

#### E4 analysis

Fair amount of true floc present. *Phycoda* (sewage flies) seta (hairs) scattered though out the sample. *Phacus* (motile green algae) present in moderate numbers.

#### N4

Very little flow rate in this last sampling port although the other port exhibited good flow rates. The turbidity of this sample was low and there appeared to be no significant presence of any of the usual predators.

#### N4 analysis

Same amount of floc and seta as in E2 sample. However the *Phacus* was found to be present in greater numbers.

#### W4

Average flow rate though this sampling port. The sample had a low turbidity and insignificant predator presence.

#### W4 analysis

Presence of true floc and *phacus*. A lot of *Phycoda* Chi ton exo skeleton remains observed.

#### W2

Good flow rate and a high turbidity were observed in this sample. There also appeared to be a significant presence of worms.

#### W3 analysis

Presence of true floc and fly remains were observed in this sample. A fair number of protozoons were also observed.

#### S2

Good flow rate and medium turbidity. Not predators were observed from the sample taken.

#### S2 analysis

Presence of true floc and fly remains were observed in this sample. A fair number of protozoons were also observed. This similar to the W3 sample, however the prevalence numbers are lower in S2 than in W3.

#### NOTES:

*Phacus* require light to grow but since they are motile, they move towards the light. Thus it is expected that they will be found in great numbers along the NTF faces that exposed to the sun for the longest period during the day.

Protozoons that were found feed on bacteria and prefer large ones like the nitrifiers.

Chi ton is a polysaccharide like cellulose but it has nitrogen groups instead of hydroxyl groups which is the case in cellulose. It can be assumed that the break down of Chi ton can increase the nitrogen concentration in the NTF but the extent of the increase is uncertain.

University of Cape Town

## SITE VISIT

19 MARCH 2006

Prior to this site visit there had been regular power cuts in the Western Cape. Due to temperatures exceeding 40°C the recirculation pumps at Nitrification Tower had over heated and stopped working. The pumps have been off for a period of two weeks (20/02/06 to 06/03/06). The aim of this site visit was to assess the extent of the impact that the tower being off-line had on its performance.

## SITE INVENTORY

The fan on the north face of the tower is still not working. Mr Kellerman said that he has not been able to fix it due to the leaking of the tower.

The tower is not leaking as excessively as it was during the last visit. There are no more pools of water around the tower. The north-west tower is still leaking significantly.

Mr Visser said the ammonia is degrading the cement in-between the bricks thus resulting in cracks and leakages along the tower. To fix the leaks would require the tower to be put off-line for an indefinite period of time. Thus it is suggested that the leaking be permitted until such time that a reliable set of data has been collected. The results of the last site visit 16/02/06 show that the tower can perform well regardless of the leaking.

The sprinklers are not being cleaned regularly. This hampers the wetting rate of the tower. Bles, who is charged of ensuring maintenance of the tower, is on leave until 13 April 2006.

There is no foam in the sump. The water level is quite high.

### North and South face evaluation 19/03/06

			Predators						Predators		
NTF FACE	Sample core	Wetting rate	Snails	Worms	Flies	NTF FACE	Sample core	Wetting rate	Snails	Worms	Flies
NORTH	N 1	*	0	0	0	SOUTH	S 1	***	-	-	-
	N 2	*	0	3	0		S 2	*	0	0	3
	N 3	*	0	3	0		S 3	*	0	0	3
	N 4	***	-	-	-		S 4	**	0	0	2

The wetting rate on both the north and south faces has declined significantly. However there is no presence of filter flies despite the decline in wetting rate. There was no sample collected from the N4 and S1 sampling ports.

### West and East face evaluation 19/03/06

			Predators						Predators		
NTF FACE	Sample core	Wetting rate	Snails	Worms	Flies	NTF FACE	Sample core	Wetting rate	Snails	Worms	Flies
WEST	W 1	***	-	-	-	EAST	E 1	***	-	-	-
	W 2	**	0	3	0		E 2	***	-	-	-
	W 3	*	0	0	0		E 3	***	-	-	-
	W 4	*	0	0	0		E 4	**	0	3	0

It appears that the east face is not being wetted at all. No samples could be collected from the top three sampling ports. However, it is surprising that there was no filter fly presence in the sample collected from the last sampling port. One would expect there to be a significant filter fly presence, which would be indicative of a fair amount of dry patches, due to the poor wetting rate that exists along this face.

### Wastewater characterisation 19/03/06

Parameter	Unit	Influent wastewater (unfiltered)	Influent wastewater (filtered)	Lagoon effluent (filtered)	NTF influent (filtered)	NTF effluent (filtered)	Final effluent (filtered)	Goal
COD	mg/L	1532	262	65	61	53	61	<75
NH <sup>+</sup> <sub>4</sub>	mg/L		44	-	39	3	22	<3
NO <sup>-</sup> <sub>3</sub>	mg/L	-	-	-	5	19	4	<15
PO <sup>-</sup> <sub>4</sub> <sup>3</sup>	mg/L	-	8	9	10	10	9	<10

## SITE VISIT

13-14 MARCH 2007

### SITE INVENTORY

- The fan on the north face of the tower is still not working. The fan on the East face has been broken since 20 Feb 2007. The fan fittings will have to be retrofitted for a new type of fan. According to Mr Kellerman the currently installed type of fan is no longer being produced.
- The tower is not leaking as excessively as it was during the last visit. There are no more pools of water around the tower. The north-west tower is still leaking significantly.
- All three pumps are still in operation
- The Flotron flow meter which measures the flow into the tower is still out of order. There is no indication of a definite date of fixing the flow meter.
- All sprinklers are operating well.
- A sewage truck arrived on the 14 March 2007. It brought three truck loads of sewage.

### LAGOON

- There are bubbles in the unaerated zone of the lagoon in the mornings. These bubbles are methane gas
- The unaerated zone of the lagoon is green in colour. This indicates a high nutrient content that lead algal growth

### NITRIFYING TOWER

- There is a **scum** layer on the top of the effluent sump in the mornings
- The tower samples generally exhibit a high content of suspended solids
- There was also a high prevalence of worms and a notable presence of the filter flies.
- The first sample port on the south face seems to be blocked. Only a meter of the two meter long sampling device can be inserted.

### FINAL EFFLUENT POND

- During the two days, there was an outflow from the plant into the river in the mornings. The outflow was significantly less when the sprinklers for the golf course were in operation. However during the afternoons there was no out flow. This could be attributed to a combination of surface water loss due to evaporation and the utilisation of the effluent for watering the golf course.

North and South face evaluation 19/03/06

			Predators						Predators		
NTF FACE	Sample core	Wetting rate	Snails	Worms	Flies	NTF FACE	Sample core	Wetting rate	Snails	Worms	Flies
NORTH	N 1	*	0	0	0	SOUTH	S 1	***	-	-	-
	N 2	*	0	3	0		S 2	*	0	0	3
	N 3	*	0	3	0		S 3	*	0	0	3
	N 4	***	-	-	-		S 4	**	0	0	2

The wetting rate on both the north and south faces has declined significantly. However there is no presence of filter flies despite the decline in wetting rate. There was no sample collected from the N4 and S1 sampling ports.

West and East face evaluation 19/03/06

			Predators						Predators		
NTF FACE	Sample core	Wetting rate	Snails	Worms	Flies	NTF FACE	Sample core	Wetting rate	Snails	Worms	Flies
WEST	W 1	***	-	-	-	EAST	E 1	***	-	-	-
	W 2	**	0	3	0		E 2	***	-	-	-
	W 3	*	0	0	0		E 3	***	-	-	-
	W 4	*	0	0	0		E 4	**	0	3	0

It appears that the east face is not being wetted at all. No samples could be collected from the top three sampling ports. However, it is surprising that there was no filter fly presence in the sample collected from the last sampling port. One would expect there to be a significant filter fly presence, which would be indicative of a fair amount of dry patches, due to the poor wetting rate that exists along this face.

## SITE VISIT

11-13 MAY 2006

### SITE INSPECTION

- North face fan is still not working
- 2 and 1/2 pumps are running since last visit
- Tower is still leaking badly
- Influent sprinklers seem to not be spraying efficiently
- Recirculation system pumps are working well
- Effluent in the sump looks dark.

### OBSERVATIONS ON THE OPERATION UNITS

- The influent raw wastewater was dosed with lime at 8am and at 5pm daily.
- There was litter in the unaerated lagoon, which I asked Bles to get rid of.
- There was at the most a trickle of an effluent flow from the final finishing pond.
- There seems to be an over growth of reeds in some of the finishing ponds.

North and South face evaluation 11/05/06

			Predators						Predators		
NTF FACE	Sample core	Wetting rate	Snails	Worms	Flies	NTF FACE	Sample core	Wetting rate	Snails	Worms	Flies
NORTH	N 1	**	0	0	0	SOUTH	S 1	*	0	0	0
	N 2	*	0	0	0		S 2	*	0	0	0
	N 3	*	0	0	0		S 3	*	0	0	0
	N 4	***	0	0	0		S 4	*	0	0	0

The through the North face of the tower was generally unsatisfactory. However, there was no sign of any form of predation. The last sampling port of the face had a lot of *animal debris*.

West and East face evaluation 11/05/06

			Predators						Predators		
NTF FACE	Sample core	Wetting rate	Snails	Worms	Flies	NTF FACE	Sample core	Wetting rate	Snails	Worms	Flies
WEST	W 1	***	0	1	0	EAST	E 1	***	0	0	0
	W 2	***	0	0	0		E 2	***	0	2	0
	W 3	*	0	0	0		E 3	***	0	2	0
	W 4	*	0	0	0		E 4	**	0	2	0

The wetting rate in through these faces is poor. However, there filter fly presence was insignificant. There is a substantial presence of worm along the East face. This has no impact on the nitrifying performance of the tower.

Most of the samples collected from the profile of the tower had a significant content of animal debris. This debris consists mainly of small wing fragments and what could be the by products of the sloughing of the biomass.

The wetting has deteriorated along all the faces of the tower except for the South face. This face has maintained its good wetting rate since the installation of the recirculation system.

## SITE VISIT

22-23 APRIL 2007

### SITE INVENTORY

One recirculation pump is out of order since 20/05/07

Another recirculation pump is leaking even though it is still in operation

All fans have been fixed

The lagoon was flooded over the weekend due to heavy rains

Aerator 2 has been out of order since 21/05/07

### LAGOON

There appears to not be a significant presence of algae in the oxidation pond anymore

There prevalence of bubbles on the surface of the unaerated zone is not so significant anymore.

### NITRIFYING TOWER

- The sump appears to have less algae
- There seems to be less suspended solids in the sump
- However there are flies in the sump. These could have been washed out by the heavy rains that took place over the weekend

Need to speak to Boet Visser about having the recirculation pumps fixed at Citrusdal instead of Cape Town. Having them fixed in Cape Town would result in a month of the tower operating with only two pumps

Decided to stop taking samples from the final effluent finishing pond. Instead samples will be taken at the influent and effluent points of the lagoon. This will help establish the performance of the lagoon with regards to COD and ammonia removal.

### MICROSCOPIC ANALYSIS OF NTF PROFILE SAMPLES

#### E3

Generally the flow on the East face is poor. The sample from E3 had an average flow rate and high turbidity. No worms could be detected with the naked eyes

#### E3 analysis

The analysis showed a significant presence of algae (of the *phacus* species). The turbidity was caused by fragments of developed flies. There was also a significant amount of fly larvae and eggs

## S2

The flow this face is generally very good. Most of the samples are clear. However S2 had a high turbidity and once again no flies or worms were visible with the naked eye.

### S2 analysis

There were algae present in this sample although not as much as in E3. The high turbidity was a result of true floc. True floc is characterised by a dominance of bacteria, inorganic substances, cellulose and endogenous residue. There was also an indication of *protista*, which are higher organisms in particular *rotifers* which feed on endogenous residue.

## N3

The wetting rate on this face is not really consistent. N3 was the only sample that had a good wetting rate on the North face profile. The sample had a low turbidity and there was a significant presence of worms that could be seen.

### N3 analysis

This sample had more fly remains than the sample from E3. Similarly to the E3 sample analysis, there was a very significant presence of algae (green *phacus* algae).

## SITE VISIT

20-24 NOVEMBER 2006

### SITE INSPECTION

- South face fan has been broken since 30/09/06
- All other fans are working
- Funny odor around the tower?
- Aerator 1 in the lagoon was fixed on 14/10/06
- The one pump has been in operation since the last visit on 03/10/06
- All sprinklers seem to spraying well
- The effluent sump had a lot of flies and worms in it
- Flies on the outside of the tower , especially in the lower regions of the tower

The fans that are currently installed are made in the UK. Thus when fans are broken, the municipality has to wait for the parts from the UK. This is both costly and time consuming. Thus Eike has offered to design a retrofit fan whose parts are ready available in South Africa at the municipalities cost.

The unaerated zone in the lagoon is green and there is a lot of litter floating on the water.

Bles is going on holiday for the whole January month in 2007; there is concern as to who is going to look after the tower. William could be a possible candidate. However, thus far no plans have been made to collect samples in the period from this visit until I get back.

### PURPOSE OF THE SITE VISIT

The aim of the site visit was to reconfigure the manifold such in the hope of improving the efficiency of the pump discharge. The bucket and stopwatch method was used to measure the flow. The time was taken to collect a fixed volume of 10 Litres. Previously the maximum water delivered though the recirculation system was roughly 9 m<sup>3</sup>/hr. With the new manifold maximum delivery achieved is approximately 29 m<sup>3</sup>/hr. The three pumps have been left in operation for the time being. Bles will soon be instructed to switch one of the pumps off so that there will at least be one pump on stand-by.

The feed sprinklers a delivering approximately 33 m<sup>3</sup>/hr which correlates with flow meter readings.

## SITE VISIT

03 OCTOBER 2006

### SITE INSPECTION

- Nitrifying trickling filter was switched off on arrival. The South fan has been broken since Friday, 30 September. Thus it was removed for repairs.
- The first aerator is still out of operation. Apparently the electrician is waiting for parts to fix the motor.
- There is an odor around the tower. Could be the algae?
- There are lots flies at the top of the tower. Could the tower be suffering from filter fly larva grazing? Will have to analyse the sample to verify.

### SAMPLING

The tower was off line for approximately 50 minutes before it was put back on line. Samples were collected about half an hour after the tower had been on line. No samples were taken along the sampling ports due to the disruption flow into the tower. However, walked the sample route with Bles to verify the locations where he was taking samples. Collected the samples that Bles had been taken for analysis.

Showed Bles how to filter the samples. From now on he should take duplicate samples at each sampling location, where one is filtered and the other is unfiltered.

## SITE VISIT

02-03 OCTOBER 2007

### SITE INVENTORY

The EBARA pump has been in operation since the last visit in August.

All the fans are working

All sprinklers working satisfactorily

### LAGOON

Scum layer on the surface of the unaerated lagoon zone. The water surface also appears green signifying algae presence.

### NITRIFYING TOWER

- The wastewater in the sump appears to have a presence of algae
- There are no visible suspended solids in the effluent NTF sample
- South face is leaking excessively compared to the other faces
- The sump is filled to the brim with which is unusual as there has not been much rain in the recent past days.
- There are flies on the outside of the West face, particularly between the W1 and W2 sampling ports.
- Filter flies have also been observed on the outside of the North face around the fan vicinity.

This was the last site visit to the CWWTP. The leaks that occur on the NTF are on the bottom 1.0 m area which has no media. Hence the leaks are seen to have not negatively impacted the internal behaviour of the NTF. It just means that there could be difficulties in reconciling the mass balance of nitrogen species on the NTF as the amount of wastewater lost due to leaks cannot be quantified. However, the leaks should be repaired as they undermine the strength of the TF structure and require the wastewater that is leaked to be rerouted to the wwtp inlet works.

## SITE INSPECTION

### NTF

- All fans are working
- The tower is still leaking excessively
- P2 has been running since the last visit
- Last row of recirculation sprinklers (on the East face) are not working. Otherwise all other sprinklers are in working order.
- Scum layer in the effluent sump
- The sump is full (water level is approximately 10 cm from the top of the structure)
- The top sampling port on the south face is blocked making it difficult to draw samples from this port. The port also seems to be slightly small as it is difficult to insert the sampling device with ease, as is the case with other sampling ports.

### LAGOON

- The first aerator is still out of operation.
- There is a scum layer on the anaerobic section of the lagoon.

### FINISHING PONDS

- There is a layer of algae growing on the first two finishing ponds
- There is an outflow to the Olifants River.

### SAMPLING

Samples were taken around the plant. Profile sample of the tower was also taken. Samples that Bles has been taking were collected. Bles has been asked to take an extra sample at the effluent lagoon as measure of checking the influent ammonia concentration. The last batch of sample he took, the NTF influent concentrations were on average half that of the raw influent which didn't make sense. The analysis of his samples showed a lot of variance which couldn't be explained. I have checked with him to make sure that he is taking the influent NTF sample at the right place.

### RECIRCULATION SYSTEM

Pump 3 was taken off to be fixed in Cape Town. The problem with this pump was apparently an electrical one. The pump usually runs for a short while before it overheats and switches off.

P3 has been checked. The o-ring came off and needs to be replaced.

The motor of P1 needs to be replaced....

## SAMPLES ANALYSIS

There is still lot of variance in the analysis results of the sample taken by Bles. Ashley suggested that I should perhaps not wait so long to collect them and get Bles to filter them for liquid and solids separation.

The tower is only removing approximately 50% of the influent ammonia.

### North and South face evaluation 06/09/06

			Predators						Predators		
NTF FACE	Sample core	Wetting rate	Snails	Worms	Flies	NTF FACE	Sample core	Wetting rate	Snails	Worms	Flies
NORTH	N 1	***	0	0	0	SOUTH	S 1	***	0	0	0
	N 2	***	0	1	0		S 2	***	0	0	0
	N 3	***	0	0	0		S 3	***	0	0	0
	N 4	*	-	-	-		S 4	***	0	0	0

### West and East face evaluation 06/09/06

			Predators						Predators		
NTF FACE	Sample core	Wetting rate	Snails	Worms	Flies	NTF FACE	Sample core	Wetting rate	Snails	Worms	Flies
WEST	W 1	***	-	-	-	EAST	E 1	*	-	-	-
	W 2	***	0	0	0		E 2	*	0	0	0
	W 3	*	0	0	0		E 3	*	0	0	0
	W 4	*	0	0	0		E 4	***	0	0	0

In some sampling ports the flow was so little that no sample could be collect. However there was negligible filter fly presence in all of the samples taken from the sampling ports. The ammonia removal profile is does not yet depict the expect profile that has been found in literature.

**Table B1 Summary of site visits to Citrusdal during 2006**

Date	16/02	19/03	11/05	14/06	27/07	24/08	06/09/06	03/10	20-24/11
Purpose	status quo Investigation	S	S	FM	S	FM orifice plate	S	S	recirculation system over-haul and flow measurement
Profile samples	Y	Y	Y	N	Y	N	Y	Y	N
NTF samples	Y	Y	Y	Y	Y	Y	Y	Y	Y

Note: S = sampling, FM = flow measurement, Y = yes, N = no

**Table B2 Summary of site visits to Citrusdal during 2007**

Date	08/02	13/03	11/04	22/05	20/06	24/07	28/08	30/09
Purpose	status quo Investigation	S and FM	S and FM	S and FM	S and FM	S and FM	S and FM	S and FM
Profile samples	Y	Y	Y	Y	Y	Y	Y	Y
NTF samples	Y	Y	Y	Y	Y	Y	Y	Y

Note: S = sampling, FM = flow measurement, Y = yes, N = no

**APPENDIX C:  
EFFLUENT RECYCLE SYSTEM**

University of Cape Town

## 1. INTRODUCTION

The introduction of forced air ventilation to the nitrifying trickling filter (NTF) resulted in a 39% improvement in apparent ammonia nitrification rates (ApANRs). However the effluent ammonia concentration during 2004 was 13.2 mgN/l which does not meet the standard effluent concentration of < 3.0 mgN/l. Hence, it was decided to increase the hydraulic loading rate (HLR) which was 1.3 m<sup>3</sup>/hr by introducing recirculation. According to literature, HLRs greater than 3.0 m<sup>3</sup>/hr should result in improved media wetting, an eradication of filter fly proliferation and consequently improved nitrification rates. The hydraulic loading on TFs can be increased by either; operating two TFs in series and alternating the leading tower regularly or by introducing an effluent TF recycle stream. Due to lack of available infrastructure for two-stage operation of the NTFs, an effluent recirculation system was designed for the single-stage operated NTF at Citrusdal. This appendix describes in brief the design and installation procedures of the effluent NTF recirculation system that was carried out during 2005 and further improvements to the system that were made during 2006.

## 2. EFFLUENT RECIRCULATION SYSTEM

The aim was design a recirculation system which had 2 times the 1Ml loading capacity of the NTF. This was to allow for flexibility in varying the HLR to obtain optimum loading conditions at the site. This estimated recycle ratio of 1:2 with respect to the influent flow rate is equivalent to a HLR of 2.8 m<sup>3</sup>/hr. It is a concern whether the structure of the TF can handle HLR of > 3.0 m<sup>3</sup>/hr because the tower was leaking at HLRs of 1.3 m<sup>3</sup>/hr without recirculation. The total energy head loss of the system was calculated to be 10.5 m of which 6 m is the static head and the local head loss due to pipe fittings is 4.5 m. The head loss through the nozzles was estimated since there was no published head loss coefficient for the particular nozzles that were used (Mofokeng, 2005).

The main components of the recirculation system are described as follows:

### 1) Pumps

Three 1.5 kw Badu Hydro Star (BHS) 35 pumps, each with an output of 33 m<sup>3</sup>/hr were chosen. The combined three pumps provide a flow rate of 99 m<sup>3</sup>/hr, which is more the design requirement of 83 m<sup>3</sup>/hr (2ML). The pump manifold is as illustrated in Figure C1, were each pump is fitted with a valve to allow for flexibility in varying the total flow out put of the system. During 2005, the system operated with two duty pumps with one pump on standby.

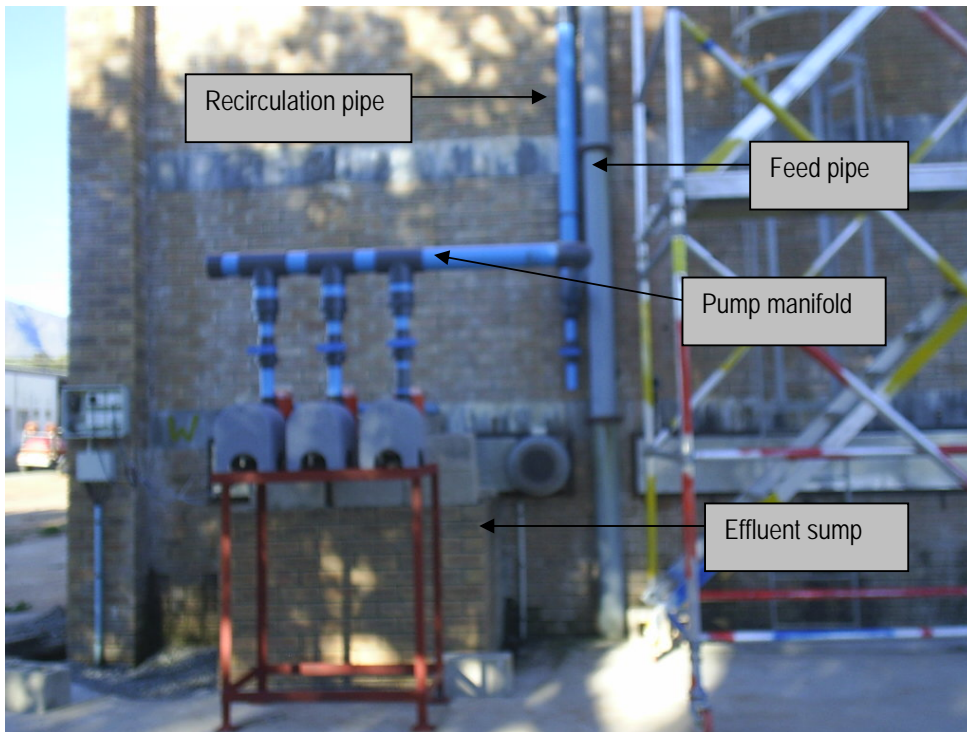

Figure C1: Pump configuration of effluent recirculation system on the West face of the NTF

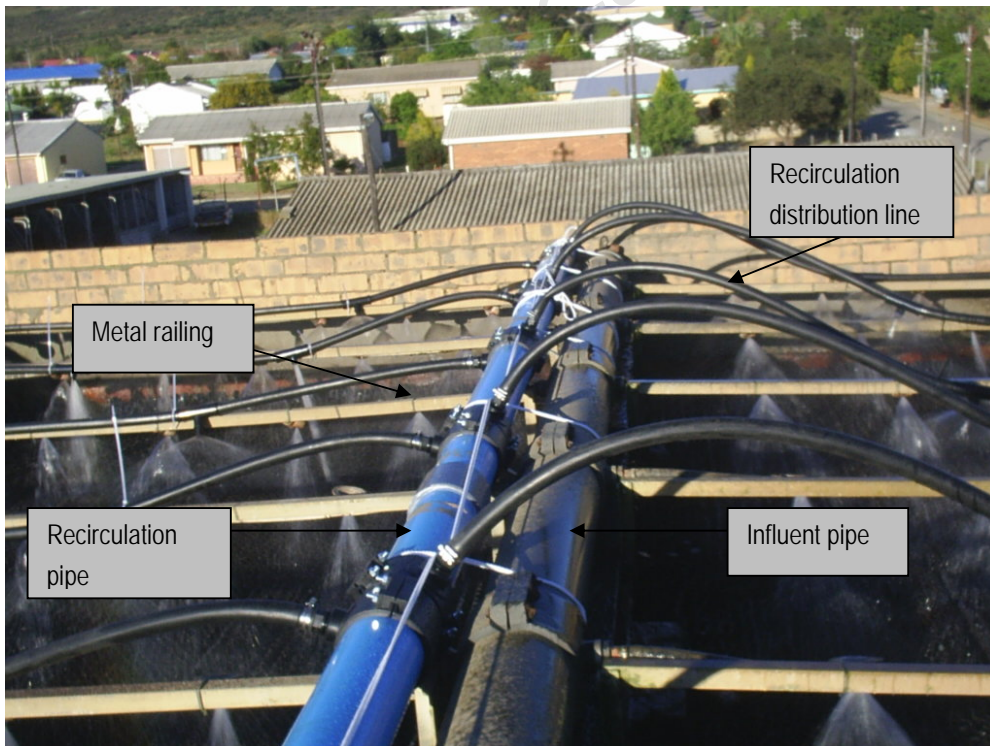

Figure C2: Increased distribution capacity on the NTF

## 2) Distribution system

The distribution system comprises of nozzles that are attached to a metal railing which is approximately 300 mm above the plastic media. The recirculation system added 36 nozzles sprinklers to the existing 71.

### 2.1 OPERATION OF THE RECIRCULATION SYSTEM

The NTF was subjected to high influent suspended solids, mainly in the form of algae, during the summer season. As a result of this, pump filters and recirculation sprinklers were clogged frequently during 2005. The following recommendations were made on the maintenance of the system;

- i) The pump filters should be cleaned at the least 2 times a week, especially during the summer period.
- ii) All the sprinklers (influent and recirculation) should also be cleaned at the least twice a week to prevent them from clogging.

There was no flow measurement device installed on the recirculation system during 2005. Hence the total HLR as a result of the effluent recycle was not determined.

## 3. PERFORMANCE OF THE RECIRCULATION SYSTEM 2006

At the start of 2006, the primary objective was to determine the effect that the increased hydraulic loading had on the ApANRs. The nitrification efficiency had improved from 31% (average value at the end of 2005) to 87 % (average value during February 2006). This is equivalent to an average apparent nitrification rate of 0.69 gN/m<sup>2</sup>d (**16.7 kgN/d removed**) in 2005 and 0.99 gN/m<sup>2</sup>d (**24.4 kgN/d removed**) in February 2006. In other words, the trickling filter removed 32 % more ammonia mass when the hydraulic load was increased. It was thus imperative to quantify the total HLR associated with the improvement in ApANRs.

The estimated flow rate with the assumed friction losses for the distribution sprinklers was approximately 93 m<sup>3</sup>/hr with all 3 pumps in operation. Flow measurements were made using a bucket and a stopwatch during June to attain an approximate total flow rate of the system. The measured flow rate of approximately 5m<sup>3</sup>/hr was significantly less than this predicted value (93 m<sup>3</sup>/hr). It was suspected that the estimated friction loss through the sprinklers must have been grossly underestimated. In addition to this, the design of the recirculation system was inefficient. Firstly, the throughput of put of each sprinkler was on average 3.3 L/min compared to 8.6 L/min for the influent sprinklers. Furthermore, the effluent recirculation system only comprised of 36 sprinklers compared to the 71 influent sprinklers and the effluent recirculation sprinklers were much more sensitive to suspended solids in the wastewater compared to the influent sprinklers. During the summer period

when there was prolific algal growth in the exposed water surfaces, the spray effect of the effluent recirculation sprinklers was observed to decrease compared to the winter. This was assumed to be analogous to a decrease in flow rate. Secondly, the manifold that connected the pumps out put was found to affect the flow rate negatively when two or more pumps were operated. When one pump is operation the manifold pipe is full and when a second pump is switched on, the jet stream hits the flow in the manifold perpendicularly resulting in energy being used up (lost) in increasing the flow with two pumps in operation. This situation was exacerbated when three pumps are in operation. This was corroborated by a decrease in flow rate when two or more pumps were operated (see Table C1). A detailed account of the measures taken to quantify the total hydraulic loading can be found in Appendix D.

**Table C1: Flow measurement using an orifice plate and verification of the obtained results with an ultrasonic portable flowmeter**

Pump combination <sup>1</sup>	Orifice plate diameter	FLOW MEASUREMENT METHOD	
		Orifice plate	Ultrasonic flow meter
	m	m <sup>3</sup> /hr	m <sup>3</sup> /hr
P2	0.075	9.86	9.732
P3	0.075	8.82	6.726
P2 & P3	0.075	6.23	8.363
P2	0.063	5.69	8.720
P3	0.063	5.09	6.250
P2 & P3	0.063	3.60	7.530

<sup>1</sup> One pump (P1) was out of order when the flow measurements were carried out.

After the assessment of the performance of the recirculation system that was installed in 2005, it was decided that the following changes should be made:

- 1) reconfigure the manifold design in Figure C1 (page C-2)
- 2) replace the effluent recirculation sprinklers with sprinklers of a higher through put and less sensitive to solids
- 3) increase the number of sprinklers to at the least match the influent sprinklers

#### 4. IMPROVEMENT TO THE RECIRCULATION SYSTEM IN 2006

The improvements to the design (carried out during November 2006) were done in order to reduce the total friction loss to the system and hence increase the out put of the system. The 90 degree bends in the manifold were replaced with wide 90 degree bends to further reduce the energy loss to the system.

Figure C3 illustrates the new pump manifold. The pumps are now essentially connected in parallel. Each outflow pipe from a pump enters a 160 mm diameter at different levels. The extension lengths of

each pump out flow differ into the 160 mm pipe. A cross section of the 160 mm manifold pipe is illustrated in Figure C4.

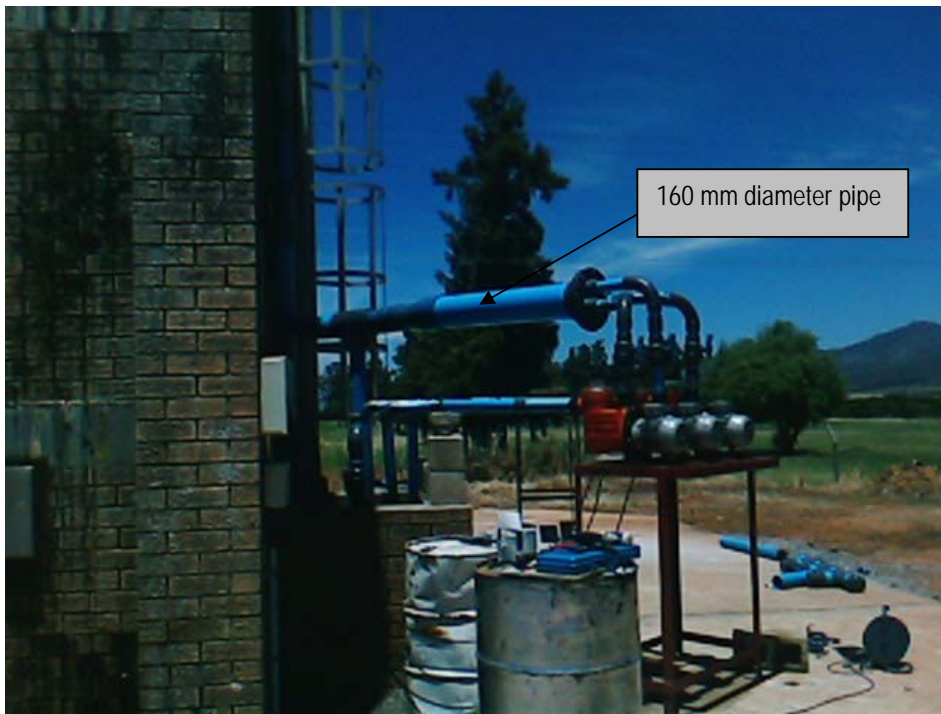

Figure C3: New pump manifold configuration 2006

With the new pump output configuration, the jet streams of the individual pump outflow pump extension do not influence each other because they are parallel to each other. This means that, when the 160 mm is full (with one pump in operation) when another pump is switched on the jet stream is introduced to the flow in a parallel (i.e. it is in the same direction as the flow existing in the pipe). Thus less energy is lost in increasing the flow rate by the joining of the two or more jet streams.

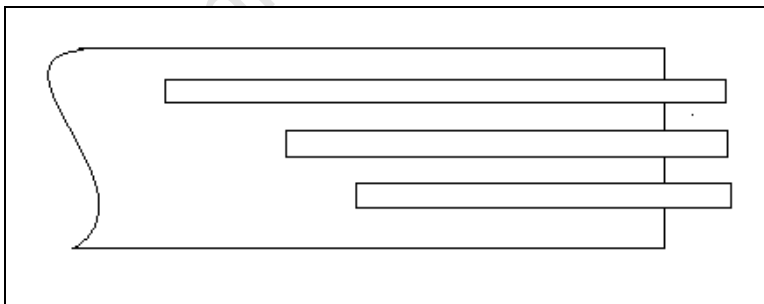

Figure C4: Diagram of the new pump manifold cross section

The effluent recirculation sprinklers were increased to 71 and a new type of sprinkler with a through put of 8.9 L/min was used. The total effluent recirculation flow rate is approximately 40 m<sup>3</sup>/hr with all three pumps in operation. This means that total flow rate to the system has been increased by 100% (ratio of

1:1 with respect to the influent flow rate). This is equivalent to a HLR of approximately 2.7 m/hr, which is less than the required minimum of 3 m/hr recommended in literature.

University of Cape Town

## APPENDIX D: EFFLUENT RECYCLE SYSTEM

1.	INTRODUCTION	1
2.	EFFLUENT RECIRCULATION SYSTEM	1
	2.1 Operation of the recirculation system	3
3.	PERFORMANCE OF THE RECIRCULATION SYSTEM 2006	3
4.	IMPROVEMENT TO THE RECIRCULATION SYSTEM IN 2006	4
	Figure C1: Pump configuration of effluent recirculation system on the West face of the NTF	2
	Figure C2: Increased distribution capacity on the NTF	2
	Figure C3: New pump manifold configuration 2006	5
	Figure C4: Diagram of the new pump manifold cross section	5

<b>TABLE OF CONTENTS</b>	<b>Page</b>
--------------------------	-------------

**APPENDIX C: EFFLUENT RECYCLE SYSTEM**

1. INTRODUCTION	C-1
2. EFFLUENT RECIRCULATION SYSTEM	C-1
2.1 Operation of the recirculation system	C-3
3. PERFORMANCE OF THE RECIRCULATION SYSTEM 2006	C-3
4. IMPROVEMENT TO THE RECIRCULATION SYSTEM IN 2006	C-4

<b>LIST OF FIGURES AND TABLES</b>	<b>Page</b>
-----------------------------------	-------------

Figure C1: Pump configuration of effluent recirculation system on the West face of the NTF	C-2
Figure C2: Increased distribution capacity on the NTF	C-3
Figure C3: New pump manifold configuration 2006	C-5
Figure C4: Diagram of the new pump manifold cross section	C-5

**APPENDIX D:  
FULL-SCALE FLOW MEASUREMENT**

University of Cape Town

## 1. INTRODUCTION

The total influent flowrate to the NTF is required in order to establish operating wetting rates at the Citrusdal NTF and for mass representation of the loading conditions. At the start of the investigation, there was a flowmeter on the pipe that delivers influent wastewater from the lagoon to the NTF. However, this flowmeter was out of order since November 2006. Furthermore, there was no flow measurement device on the recirculation system when it was installed in October 2005.

There were numerous attempts at designing and installing a flow measurement device during the first half of 2006. These are summarised in this appendix together with the final flow measurement procedure that was adopted.

## 2. FLOW MEASUREMENT DEVICES

The following measuring devices were considered, hiring a portable flowmeter, installing an in-line flowmeter on the recirculation feed line or installing an orifice plate flowmeter. The options of either hiring a portable flow meter or installing an in-line flow meter turned out to be too costly considering the limited financial resources at hand. The option of installing an orifice plate was the most economical for the projected research period. Research has shown that orifice plates gave relatively good accuracies, which are within one percent if detail is taken in the design and installation of the orifice plate ([www.usbr.gov/pmts/hydraulic\\_lab/pubs/wmm/chap14\\_03.html](http://www.usbr.gov/pmts/hydraulic_lab/pubs/wmm/chap14_03.html)).

### 2.1 ORIFICE PLATE DESIGN PROCEDURE

The orifice plate design guidelines used were obtained from [www.usbr.gov/pmts/hydraulic\\_lab/pubs/wmm/chap14\\_03.htm](http://www.usbr.gov/pmts/hydraulic_lab/pubs/wmm/chap14_03.htm). Standard taping positions for differential pressure readings of one diameter length upstream of the flange and half a diameter length down stream were used in this design (Figure C1). The advantage of this is that flexibility is given in varying the orifice diameter because the taping positions are based on the diameter of the main pipe and not of the orifice plate.

#### 2.1.1 Determining the coefficient of discharge ( $C_d$ )

The coefficient to discharge was determined mathematically by apply the Stolz equation ([www.usbr.gov/pmts/hydraulic\\_lab/pubs/wmm/chap14\\_03.htm](http://www.usbr.gov/pmts/hydraulic_lab/pubs/wmm/chap14_03.htm)).

$$C_d = 0.5959 + 0.0312\beta^{2.1} - 0.1840\beta^8 + 0.0029\beta^{2.5}(10^6/Re)^{0.75} + 0.0900(L_1/D)[\beta^4/(1 - \beta^4)] - 0.0337(L_2/D)\beta^3 \quad (14-3)$$

where:

$C_d$  = coefficient of discharge

$L_1$  = the tap distance from the upstream face of the plate

$L_2$  = the tap distance from the downstream face of the of the orifice plate

$D$  = the pipeline diameter

$\beta$  = the ratio of orifice diameter to pipe diameter

$Re$  = the Reynolds number ( $VD/\nu$ )

$V$  = the pipeline velocity

$\nu$  = the kinematic viscosity of the water

The use of this equation is regarded to be accurate provided that the pressure taping arrangement is standard ([www.usbr.gov/pmts/hydraulic\\_lab/pubs/wmm/chap14\\_03.htm](http://www.usbr.gov/pmts/hydraulic_lab/pubs/wmm/chap14_03.htm)). It was decided, not to calibrate the orifice plate in order to determine the  $C_d$  value because the error in the flowrate measurement is largely due to inaccurately reading off the pressure gauge rather than inaccurate  $C_d$  values.

### 2.1.2 Predicted flowrates to the system

The three BHS 35 pumps each with a capacity of 1.5 kW did not come with the manufacturers pump characteristic curves. Hence, pump characteristic curves were generated for the recirculation system configuration in order to estimate the total flow that the system will provide with a maximum of three pumps in operation.

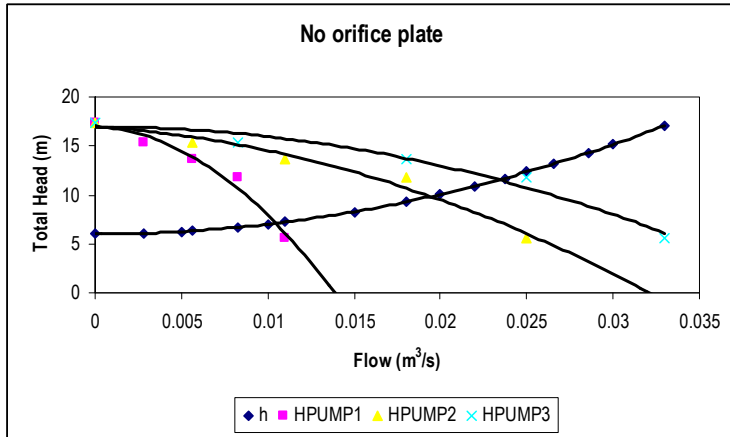

Figure D1: Head loss when there is no orifice plate

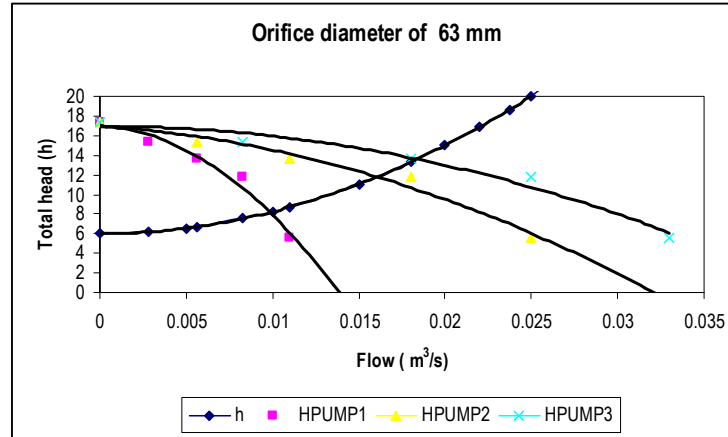

Figure D2: Head loss with a 63 mm diameter orifice plate

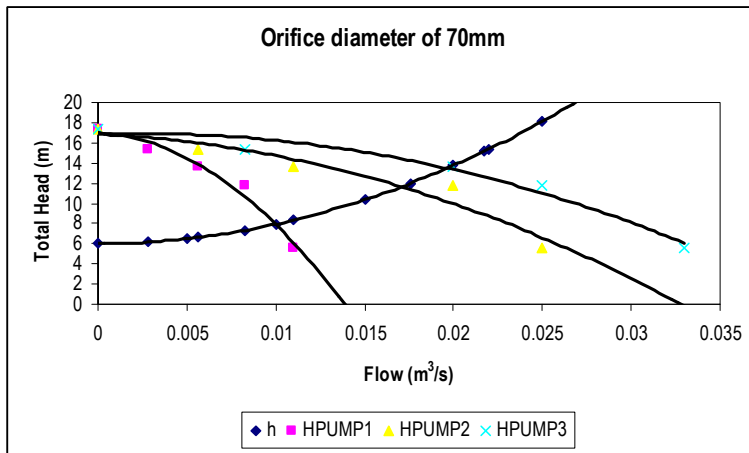

Figure D3: Head loss with a 70 mm diameter orifice plate

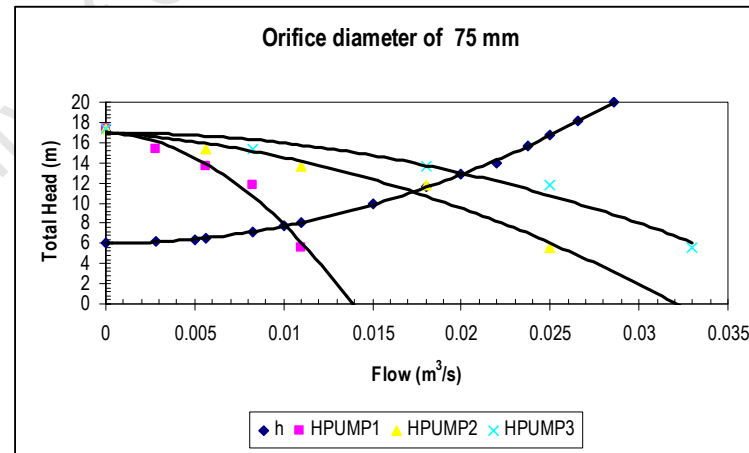

Figure D4: Head loss with a 75 mm diameter orifice plate

The static head to the system was 6 m; the friction loss through the pipe fitting was determined using the minor loss coefficients ( $k$ ) obtained from published values. However, the minor values loss coefficient for the flow through the nozzles was estimated at 0.3 since there were no published values available. This estimated value is 50 % greater than the published value of the minor loss coefficient through a reducer. The  $C_d$  was calculated based on the assumption that  $Re \approx 1 \times 10^6$  and hence remained the same for each orifice diameter tested. Figures C1 to C4 show the predicted flowrates that would be achieved with orifice plate diameters of 63, 70 and 75 mm respectively. Table C1 summarises the maximum flow output of the system with three pumps in operation.

**Table D1: Summary of the predicted flowrates using varying orifice plate diameter flowmeters**

Parameter	Units	No orifice plate	63 mm diameter	70 mm diameter	75 mm diameter
Total head loss (H)	m	12	13.2	13.4	12.9
Flowrate (Q)	m <sup>3</sup> /hr	82.8	64.8	70.2	72.0
$\Delta h$ (orifice)	m	-	3.9	2.9	0.7
$\Delta$ Pressure (orifice)	KPa	-	36	13	6
$C_d$		-	0.61	0.62	0.62

The initial assumption of  $Re$  remaining constant with varying flows through an orifice plate flowmeter was verified by calculating the actual  $Re$  number for the varying flowrates. For the orifice plate diameter flowmeters tested, the following was found;

- Orifice diameter of 63 mm  
 $C_d = 0.62$  for  $Q < 72$  m<sup>3</sup>/hr and  $C_d = 0.61$  for  $Q > 72$  m<sup>3</sup>/hr
- Orifice diameter of 70 mm  
 $C_d = 0.63$  for  $Q < 30$  m<sup>3</sup>/hr and  $C_d = 0.62$  for  $Q > 30$  m<sup>3</sup>/hr
- Orifice diameter of 75 mm  
 $0.65 < C_d < 0.64$  for  $Q < 54$  m<sup>3</sup>/hr and  $C_d = 0.63$  for  $Q > 54$  m<sup>3</sup>/hr

The  $C_d$  does not vary much from the ones calculated based on the assumed  $Re$  value, hence the assumption has been accepted as reasonable.

### 2.1.3 Actual orifice plate flowmeter results

The orifice plates were made from a brass plate with a thickness of 5 mm. The installation took place on 24/08/06. It was decided that a portable flowmeter should be hired in this case in order to verify the results obtained from the flow measured using the orifice plate. Upon the investigators arrival on site, only two of the three pumps on the recirculation system were operating. Hence, the flow measurements were run with only two pumps and not the maximum three as it had been anticipated. Furthermore, due to cost implications, the hired flowmeter was only available to the investigators for one full day, thus there was limited time in which to test all of the orifice diameters. Because of this, only the 63 and 75 mm diameter orifice plates were tested. Table D2 is a summary of the measured flowrates using the orifice plate flowmeter and the ultrasonic portable flowmeter.

**Table D2: Flow measurement using an orifice plate and verification of the obtained results with an ultrasonic portable flowmeter**

Pump combination	Orifice plate diameter	FLOW MEASUREMENT METHOD	
		Orifice plate	Ultrasonic flow meter
	m	m <sup>3</sup> /hr	m <sup>3</sup> /hr
P2	0.075	9.86	9.732
P3	0.075	8.82	6.726
P2 & P3	0.075	6.23	8.363
P2	0.063	5.69	8.720
P3	0.063	5.09	6.250
P2 & P3	0.063	3.60	7.530

The flowrates measured using both devices were significantly lower than the flowrates that were predicted. Theoretically, since the pumps should be operating in parallel, the maximum predicted flowrate for the operation of three pumps means that each pump contributes equivalent flow to the total out put. It is therefore expected that with a 63 and 75 mm orifice diameter the flow out put from one pump should be 21.6 m<sup>3</sup>/hr and 24.0 m<sup>3</sup>/hr respectively. These predicted values are grossly higher than the actual values reported in Table D2. It has been deduced that the assumed value of the minor loss coefficient for the sprinklers was grossly underestimated as it is the only assumption in the calculations that could not be verified. In addition, the ultrasonic flowmeter readings are in most cases higher than those achieved using the orifice plate flow meter. It is suspected the error in the calculation of the flowrate using the orifice plate flowmeter was in the reading of the gauge pressure instruments. Due to such low flowrates, an error in the reading of the upstream and downstream pressure gauges would have a much more significant effect on the flowrate calculations because of the small differential pressure readings that were obtained.

It was also observed that when two pumps were in operation, the total flowrate of the system decreased regardless of the flow measurement device used. This should not be the case if the pumps are operating in parallel, the flow should double. It was inferred from the flow measurement and pressure results, that the manifold that was designed and installed in 2005 was inefficient in providing the required minimum flow out put of approximately 40 m<sup>3</sup>/hr. Hence the manifold system was redesigned, a detailed account of this can be found in Appendix C.

## 2.2 BUCKET AND STOP WATCH METHOD FOR MEASURING FLOW

After the redesign of the recirculation system manifold in November 2006, it was decided that the bucket and stop watch method would be just as effective and economical in measuring the total NTF influent flowrate. It has been assumed the stop watch accuracy is +/- 0.1s and the bucket accuracy is +/- 1%. It was decided that the results would be more accurate if the time that it takes to collect a fixed volume of 10 L of wastewater was measured. On average, the flowrate was measured from approximately 24 % of the recirculation and influent feed sprinklers that were randomly selected. The investigators kept the

time and the plant operators collected 10 L of wastewater in calibrated bucket. Table C3 is a summary of the flow measurements of the influent and recirculation flowrate during the investigation period. The flowmeter on the influent feed pipeline has been out of order since November 2006 and was still not fixed by the end of the research period in September 2007.

**Table D3: Summary of the flowrates obtained using the bucket and stop watch method for the feed and recirculation sprinklers of the NTF**

Year	Month	NTF influent flowrate			NTF recirculation flowrate		
		No. of samples	Flow m <sup>3</sup> /hr	SSD	No. of samples	Flow m <sup>3</sup> /hr	SSD
2006	Nov	27	29.5	0.3	20	29.2	0.4
2007	Feb	12	41.1	0.1	20	27.5	0.5
2007	April	11	40.1	0.2	11	33.1	0.4
2007	May	15	40.8	0.4	17	37.0	0.2
2007	June	15	40.7	0.3	17	30.1	0.2
2007	July	15	40.3	0.2	17	31.4	0.1
2007	Aug	-	-	-	17	27.4	0.1

The standard deviation on the flowrate results using the bucket and stop watch method was regarded to be acceptable. Due to the amount of time spent on devising ways to measure flow on the NTF, the orifice plate was removed and the bucket and stop watch method was adopted permanently so the investigators could concentrate on the main objectives of the research.

<b>1.</b>	<b>INTRODUCTION</b>	<b>D-1</b>
<b>2.</b>	<b>FLOW MEASUREMENT DEVICES</b>	<b>D-1</b>
<b>2.1</b>	<b>Orifice plate design procedure</b>	<b>D-1</b>
2.1.1	Determining the coefficient of discharge ( $C_d$ )	D-1
2.1.2	Predicted flowrates to the system	D-2
2.1.3	Actual orifice plate flowmeter results	D-4
<b>2.2</b>	<b>Bucket and stop watch method for measuring flow</b>	<b>D-5</b>
	Figure D1: Head loss when there is no orifice plate	D-3
	Figure D2: Head loss with a 63 mm diameter orifice plate	D-3
	Figure D3: Head loss with a 70 mm diameter orifice plate	D-3
	Figure D4: Head loss with a 75 mm diameter orifice plate	D-3
	Table D1: Summary of the predicted flowrates using varying orifice plate diameter flowmeters	D-4
	Table D2: Flow measurement using an orifice plate and verification of the obtained results with an ultrasonic portable flowmeter	D-5
	Table D3: Summary of the flowrates obtained using the bucket and stop watch method for the feed and recirculation sprinklers of the NTF	D-6

## TABLE OF CONTENTS

Page

### APPENDIX D: FULL-SCALE FLOW MEASUREMENT

1.	INTRODUCTION	D-1
2.	FLOW MEASUREMENT DEVICES	D-1
2.1	Orifice plate design procedure	D-1
2.1.1	Determining the coefficient of discharge ( $C_d$ )	D-1
2.1.2	Predicted flowrates to the system	D-2
2.1.3	Actual orifice plate flowmeter results	D-4
2.2	Bucket and stop watch method for measuring flow	D-5

### LIST OF FIGURES AND TABLES

Page

Figure D1:	Head loss when there is no orifice plate	D-3
Figure D2:	Head loss with a 63 mm diameter orifice plate	D-3
Figure D3:	Head loss with a 70 mm diameter orifice plate	D-3
Figure D4:	Head loss with a 75 mm diameter orifice plate	D-3
Table D1:	Summary of the predicted flowrates using varying orifice plate diameter flowmeters	D-4
Table D2:	Flow measurement using an orifice plate and verification of the obtained results with an ultrasonic portable flowmeter	D-5
Table D3:	Summary of the flowrates obtained using the bucket and stop watch method for the feed and recirculation sprinklers of the NTF	D-6

**APPENDIX E:  
FULL-SCALE NITRIFYING TRICKLING FILTER PROFILE  
SUMMARY**

University of Cape Town

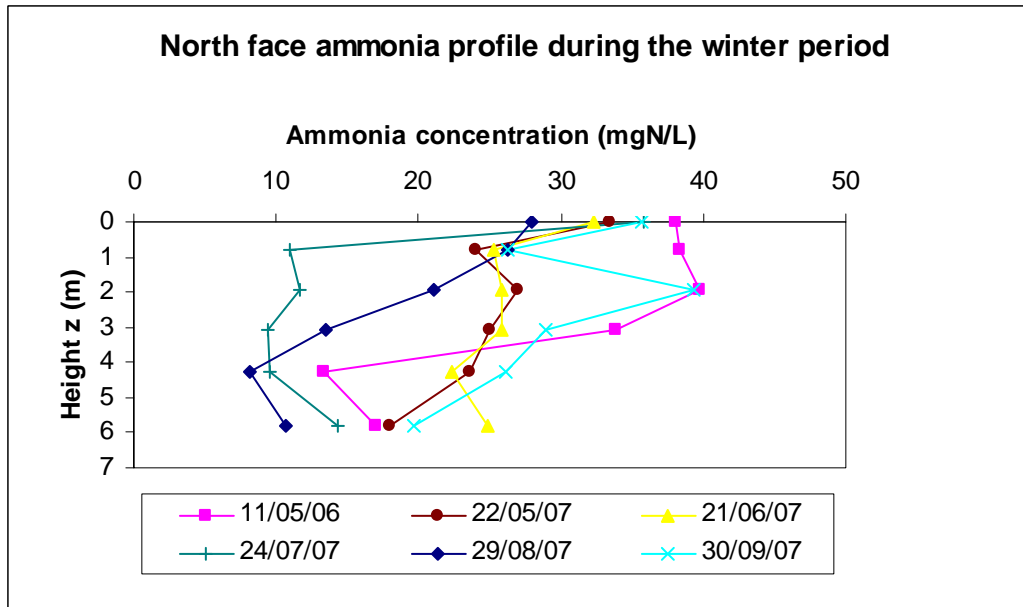

Figure N1: North face ammonia profile during the winter period

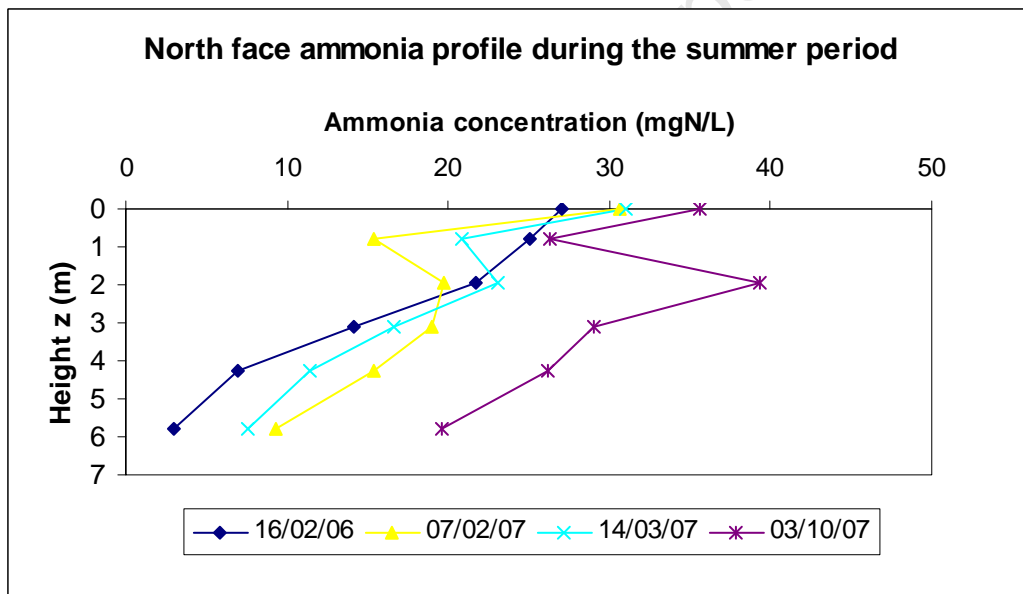

Figure N2: North face ammonia profile during the summer period



Table N2: North Face wetting rate profile

Sampling Port	15/09/05	16/02/06	19/03/06	11/05/06	07/02/07	14/03/07	14/04/07	22/05/07	19/06/07	25/07/07	28/08/07	30/09/07
1	A	G	G	A	G	G	G	P	G	P	P	P
2	G	G	G	G	G	G	G	P	G	G	G	G
3	A	G	G	G	G	G	G	G	G	G	G	G
4	A	G	P	P	P	A	P	A	P	P	P	P
HLR (m/hr)	1.7	2.5	0.6	1.7	2.3	2.3	2.7	2.8	2.3	2.3	2.3	2.3

\*P = poor, A = average and G = good. HLR includes recirculation

yellow colour = summer green colour = winter

Table N3: North Face turbidity profile

Sampling Ports	11/05/06	07/02/07	14/03/07	14/04/07	22/05/07	19/06/07	25/07/07	28/08/07	30/09/07
1	M	H	M	C	M	C	M	M	L
2	C	H	H	C	M	L	H	H	H
3	C	H	M	M	M	L	H	H	H
4	H	L	H	M	M	L	M	H	H
HLR (m/hr)	1.7	2.3	2.3	2.7	2.8	2.3	2.3	2.3	2.3

\*L = low, M = medium and H = high C = clear. HLR includes recirculation

yellow colour = summer green colour = winter

The turbidity profile of the North face (Table N3) showed a good wetting in the second and third sampling ports and the last sampling port a poor wetting rate. The profile turbidity of the North face has been irregular. The turbidity profile samples go from clear at the top regions of the NTF to medium turbidity in the lower regions.

Microbial analysis showed a significant amount of fly debris, *nematode* (worms) and *Phacus* (motile green algae). The presence of true floc was sparse in the North profile samples.

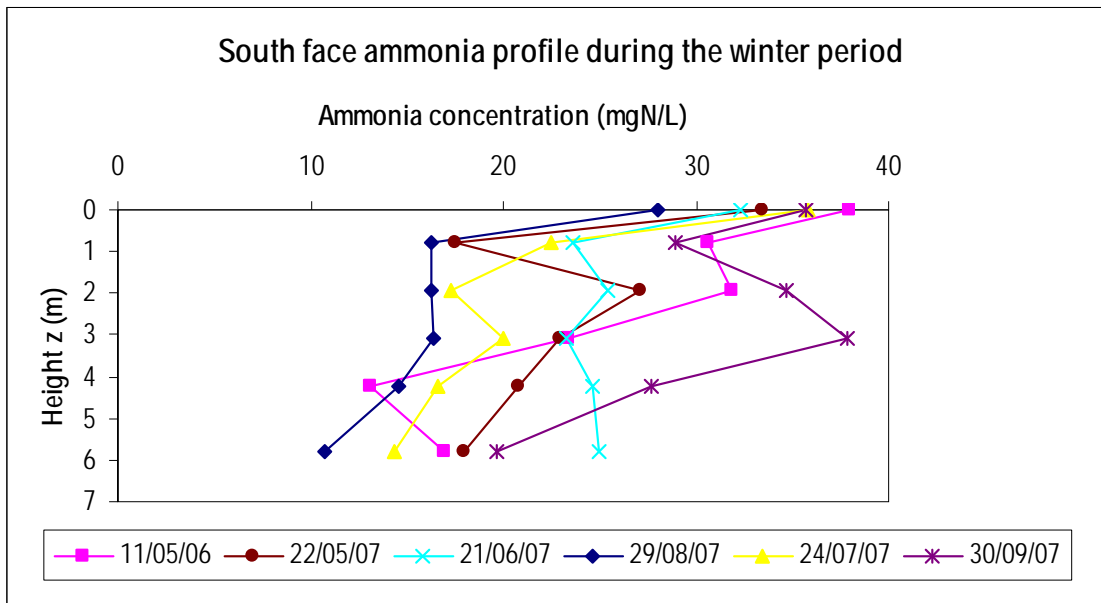

Figure S1: South face ammonia concentration profile during the winter period

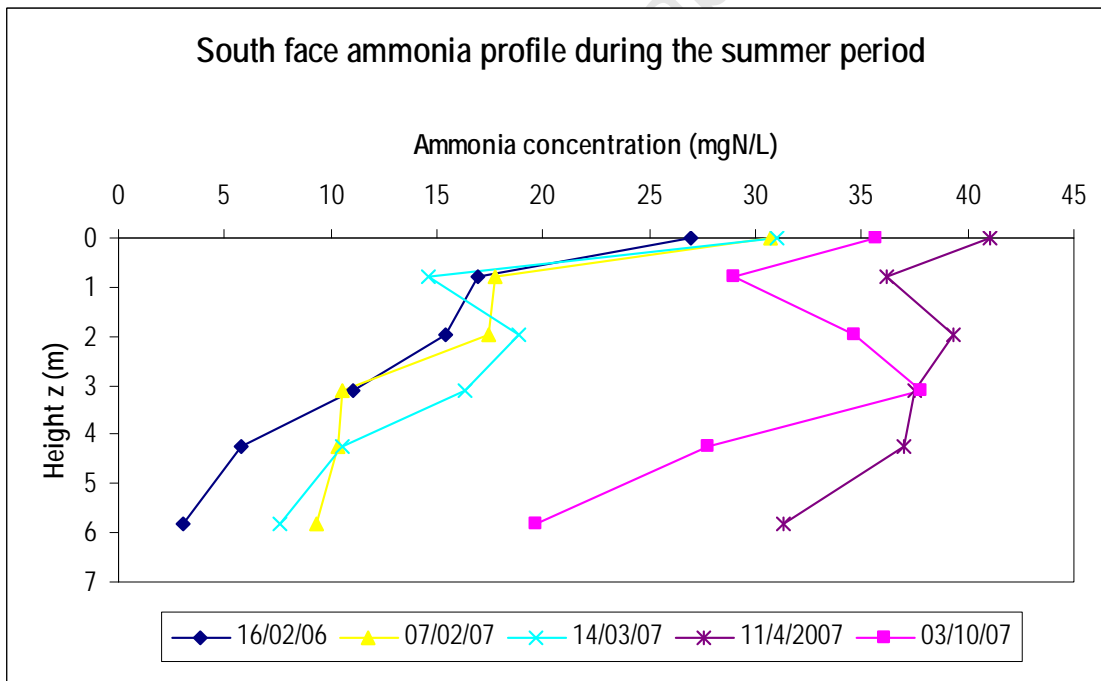

Figure S2: South face ammonia profile during the summer period



Table S2: South Face wetting rate profile

Sampling Port	15/09/05	16/02/06	19/03/06	11/05/06	07/02/07	14/03/07	14/04/07	22/05/07	19/06/07	25/07/07	28/08/07	30/09/07
1	G	G	P	G	G	G	G	G	G	G	P	G
2	G	G	G	G	G	G	G	G	G	G	G	G
3	G	G	G	G	G	G	G	G	G	G	G	G
4	G	G	A	G	G	G	G	G	G	G	G	G
HLR (m/hr)	1.7	2.5	0.6	1.7	2.3	2.3	2.7	2.8	2.3	2.3	2.3	2.3

\*P = poor, A = average and G = good. HLR includes recirculation

yellow colour = summer green colour = winter

Table S3: South Face turbidity profile

Sampling Ports	11/05/06	07/02/07	14/03/07	14/04/07	22/05/07	19/06/07	25/07/07	28/08/07	30/09/07
1	C	L	L	C	C	L	L	L	L
2	H	M	H	M	H	M	H	H	H
3	H	L	M	M	M	L	H	H	H
4	L	L	L	M	L	L	L	L	H
HLR (m/hr)	1.7	2.3	2.3	2.7	2.8	2.3	2.3	2.3	2.3

\*L = low, M = medium and H = high C = clear. HLR includes recirculation

yellow colour = summer green colour = winter

The South face has exhibited the best wetting of the other NTF profile sample faces. The turbidity of the samples ranged from clear to high and the increase in HLR did not have an effect on the turbidity (see Table S3).

Microbial analysis of the South profile samples exhibited a less significant presence of fly debris and nematode in comparison to the other profile samples. There was no alga observed in the samples, which was expected because the South face does not receive direct sunlight. A distinct presence of true floc was observed with a presence of highly motile protozoan which feed on large bacteria such as nitrifiers.

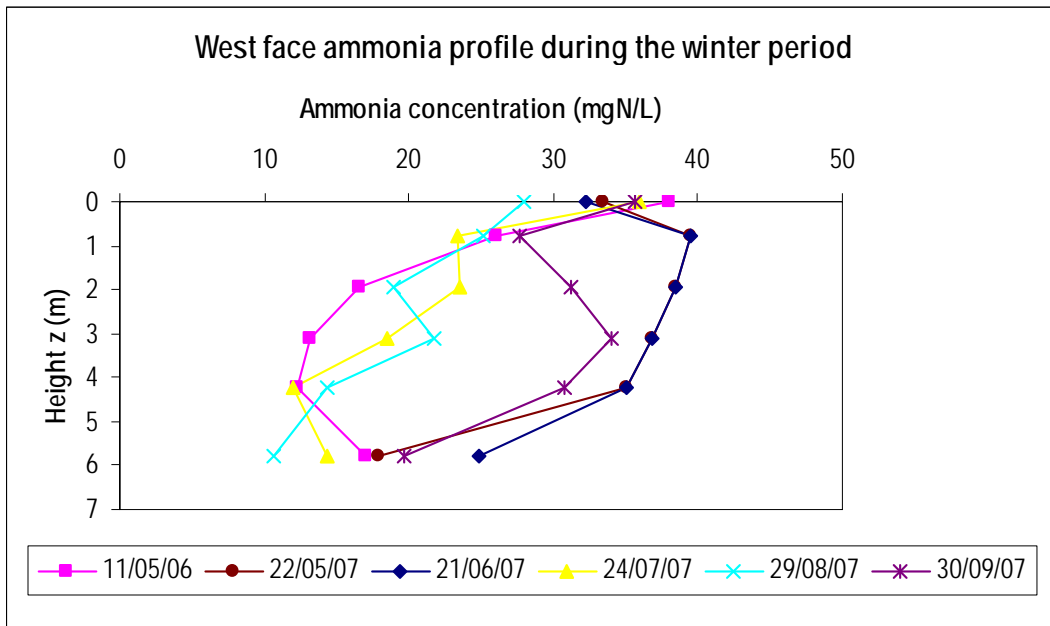

Figure W1: West face ammonia profile during the winter period

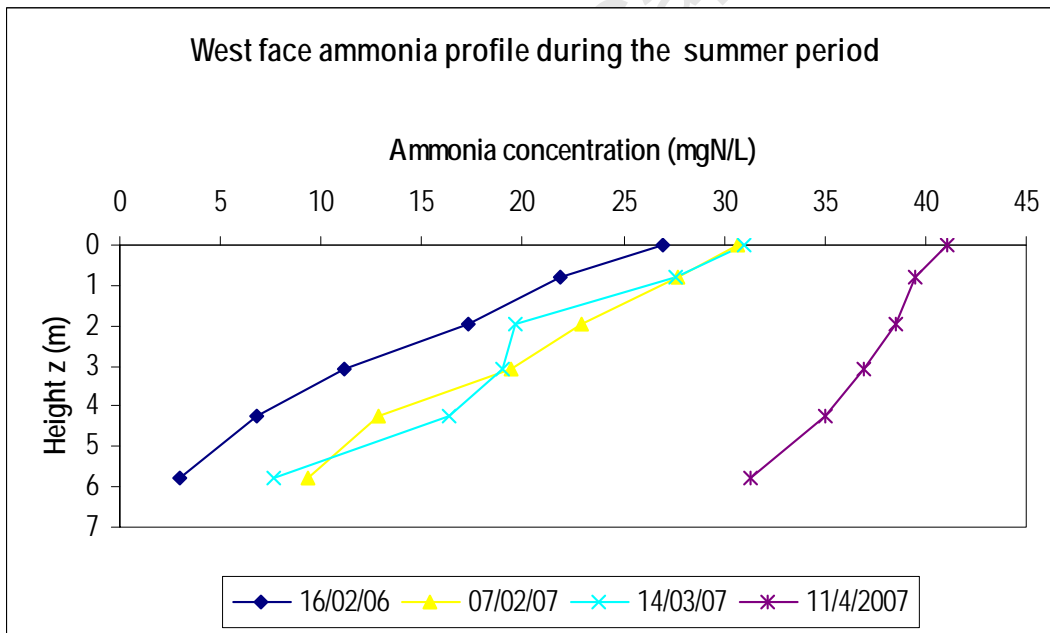

Figure W2: West face ammonia profile during the summer period

Table W1: West Face predation profile

Sample	15/09/05			16/02/06			19/03/06			11/05/06			06/09/06			07/02/07			14/03/07			14/04/07			22/05/07			19/06/07			25/07/07					
Port	Predation			Predation			Predation			Predation			Predation			Predation			Predation			Predation			Predation			Predation								
	F	S	W	F	S	W	F	S	W	F	S	W	F	S	W	F	S	W	F	S	W	F	S	W	F	S	W	F	S	W	F	S	W	F	S	W
1	1	0	0	0	0	0	-	-	-	0	0	1	-	-	-	0	0	1	0	0	1/2	0	0	1	0	0	1/2	0	0	0	0	0	0	0	0	0
2	1	0	0	0	0	0	0	0	3	0	0	0	0	0	0	0	0	0	0	0	0	0	0	0	0	0	0	0	0	0	0	0	1	0	0	0
3	1	0	1	0	0	0	0	0	0	0	0	0	0	0	0	0	0	0	0	0	0	0	0	0	0	0	0	0	0	0	0	0	0	0	0	0
4	1	0	0	0	0	0	0	0	0	0	0	0	0	0	0	0	0	0	0	0	0	0	0	0	0	0	0	0	0	0	0	0	0	0	0	0
Sample	28/08/07			30/09/07																																
Port	Predation			Predation																																
	F	S	W	F	S	W	F	S	W	F	S	W	F	S	W	F	S	W	F	S	W	F	S	W	F	S	W	F	S	W	F	S	W	F	S	W
1	0	0	0	0	0	0																														
2	0	0	0	0	0	0																														
3	0	0	0	0	0	0																														
4	0	0	0	0	0	0																														

\*F = flies; S = snails; W = worms. Scale of 0 to 3 where 0 is the no presence and the 3 is the most  
 \* - denotes no sample collected

Table W2: West Face wetting rate profile

Sampling Ports	15/09/05	16/02/06	19/03/06	11/05/06	07/02/07	14/03/07	14/04/07	22/05/07	19/06/07	25/07/07	28/08/07	30/09/07
1	G	G	P	P	A	G	G	A	A	G	G	-
2	G	G	A	P	G	P	A	P	G	G	P	-
3	G	G	G	G	G	G	G	G	G	G	G	G
4	G	G	G	G	G	G	G	G	A	G	G	G
HLR (m/hr)	1.7	2.5	0.6	1.7	2.3	2.3	2.7	2.8	2.3	2.3	2.3	2.3

\*P = poor, A = average and G = good. HLR includes recirculation

yellow colour = summer green colour = winter

Table W3: West Face turbidity profile

Sampling Ports	11/05/06	07/02/07	14/03/07	14/04/07	22/05/07	19/06/07	25/07/07	28/08/07	30/09/07
1	L	H	L	M	C	C	H	H	-
2	H	M	H	M	H	H	H	H	-
3	C	H	L	C	L	L	M	H	H
4	H	M	L	C	L	L	L	L	H
HLR (m/hr)	1.7	2.3	2.3	2.7	2.8	2.3	2.3	2.3	2.3

\*L = low, M = medium and H = high C = clear. HLR includes recirculation

yellow colour = summer green colour = winter

The West face a poor wetting rate from the analysis of samples from the first two sampling ports, thus it is expected that the turbidity of these sample would be medium to high, which is the case in Table W3.

Microbial analysis was done on the profile winter samples of 2007. The West face always had a significant presence of true floc during the winter period. True floc does not necessarily mean that there is nitrifying biomass present. There was no equipment available during the investigation period for the further analysis of constituencies of the true floc. There was a fair amount of *phacus* (green motile algae) except for during the month of August during which there was no observed biological activity. The profile samples also showed a considerable presence of fly debris or remains, *rotifers* and *nematodes* (primitive segmented worm).

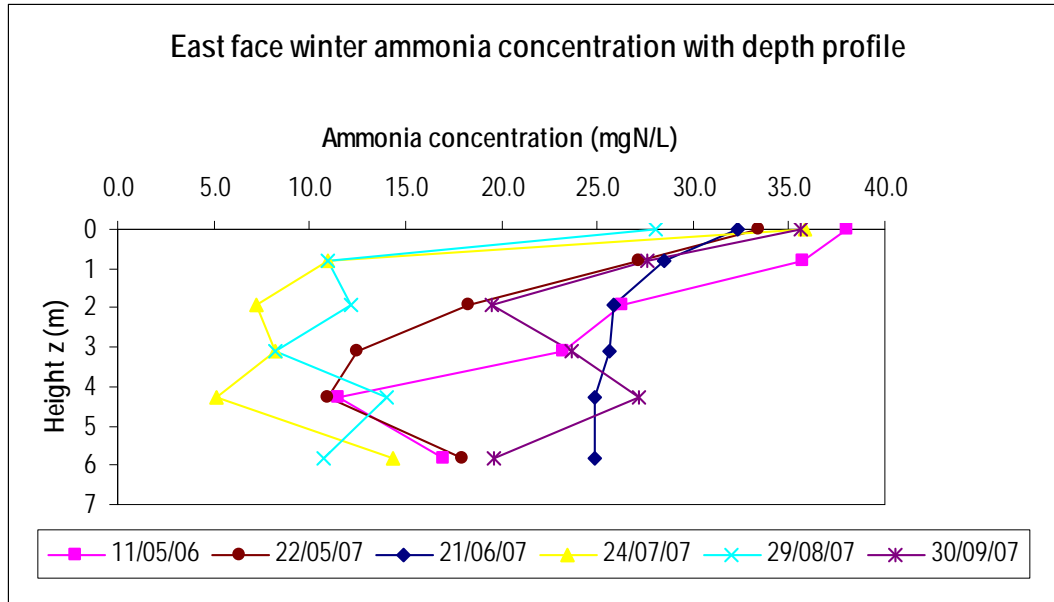

Figure E1: East face ammonia concentration profile during the winter period

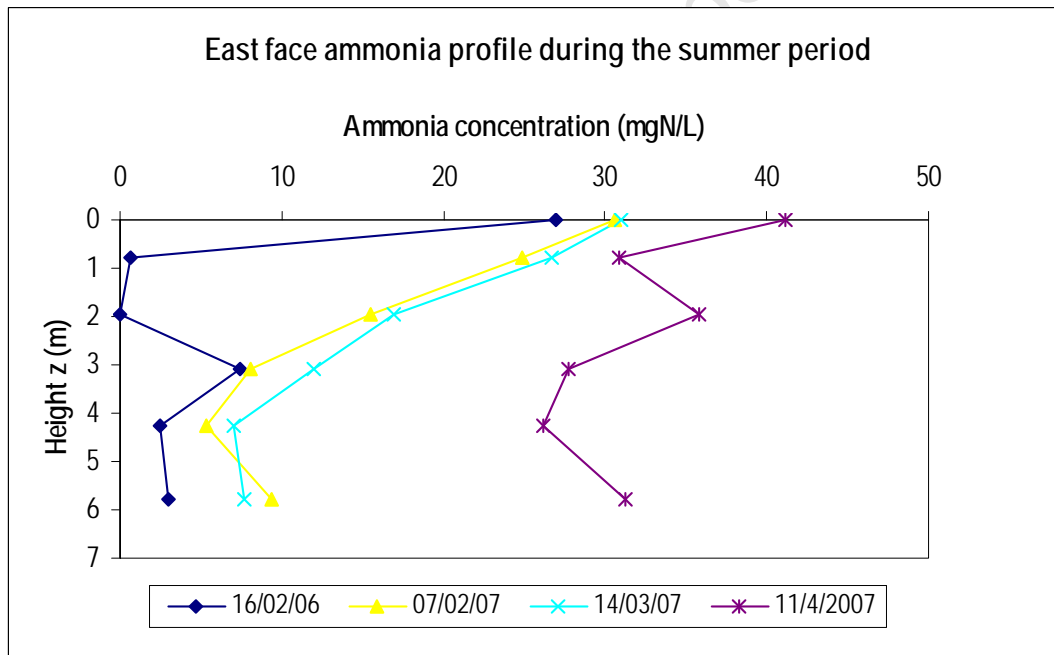

Figure E2: East face ammonia profile during the summer period



Table E2: East Face wetting rate profile

Sampling Port	15/09/05	16/02/06	19/03/06	11/05/06	07/02/07	14/03/07	14/04/07	22/05/07	19/06/07	25/07/07	28/08/07	30/09/07
1	A	A	P	P	P	P	P	P	P	P	-	-
2	A	A	P	P	A	A	A	P	P	P	P	P
3	A	A	P	P	G	P	A	P	G	P	P	P
4	A	G	A	A	G	G	G	G	G	G	A	A
HLR (m/hr)	1.7	2.5	0.6	1.7	2.3	2.3	2.7	2.8	2.3	2.3	2.3	2.3

\*P = poor, A = average and G = good. HLR includes recirculation

yellow colour = summer green colour = winter

Table E3: East Face turbidity profile

Sampling Ports	11/05/06	07/02/07	14/03/07	14/04/07	22/05/07	19/06/07	25/07/07	28/08/07	30/09/07
1	-	M	-	M	-	M	-	-	-
2	H	M	H	M	H	M	M	H	M
3	H	M	M	M	H	L	L	M	H
4	H	H	L	H	H	H	H	H	H
HLR (m/hr)	1.7	2.3	2.3	2.7	2.8	2.3	2.3	2.3	2.3

\*L = low, M = medium and H = high C = clear. HLR includes recirculation

yellow colour = summer green colour = winter

The East face which generally has a poor wetting rate also exhibited profile samples were on average of a medium to high turbidity. The solids were mainly of fly remains. The increase in HLR has not had an effect on the turbidity of the profile samples (see Figure 6.6). The flow was so poor through the first sampling port that in most cases no sample was collected. The East face exhibited significant amount of filter fly larvae and eggs, and *phacus*. The high turbidity of the samples during July and August were due to the presence of true floc. There was also a significant amount of *nematodes* and fly debris present in the samples collected during these months of high rainfall.

## LIST OF FIGURES AND TABLES

Page

### APPENDIX E: FULL-SCALE NITRIFYING TRICKLING FILTER PROFILE SUMMARY

Figure N1: North face ammonia profile during the winter period	E-1
Figure N2: North face ammonia profile during the summer period	E-2
Table N1: North Face predation profile	E-3
Table N2: North Face wetting rate profile	E-3
Table N3: North Face turbidity profile	E-3
Figure S1: North face ammonia profile during the winter period	E-4
Figure S2: North face ammonia profile during the summer period	E-5
Table S1: North Face predation profile	E-6
Table S2: North Face wetting rate profile	E-6
Table S3: North Face turbidity profile	E-6
Figure W1: North face ammonia profile during the winter period	E-7
Figure W2: North face ammonia profile during the summer period	E-8
Table W1: North Face predation profile	E-9
Table W2: North Face wetting rate profile	E-9
Table W3: North Face turbidity profile	E-9
Figure E1: North face ammonia profile during the winter period	E-10
Figure E2: North face ammonia profile during the summer period	E-11
Table E1: North Face predation profile	E-12
Table E2: North Face wetting rate profile	E-12
Table E3: North Face turbidity profile	E-12

TABLE OF CONTENTS	Page
ABSTRACT	i
EXECUTIVE SUMMARY	iii
CHAPTER 1: INTRODUCTION: EXTERNAL NITRIFICATION OF LAGOON EFFLEUNT IN A TERTIARY NITRIFYING TRICKLING FILTER – FULL SCALE INVESTIGATION	
1.1 OBJECTIVE OF THE RESEARCH INVESTIGATION	1-1
1.2 BACKGROUND TO THE STUDY	1-1
1.3 LIMITATIONS TO THE RESEARCH	1-4
1.4 PROBLEMS TO BE INVESTIGATED	1-4
1.5 SCOPE OF THE RESEARCH	1-5
CHAPTER 2: LITERATURE REVIEW	
2.1 INTRODUCTION	2-1
2.2 NITRIFICATION PROCESS DEFINITION AND REQUIREMENTS	2-1
2.3 DEVELOPMENTS OF THE EXTERNAL NITRIFICATION (EN) CONCEPT	2-2
2.4 EXTERNAL NITRIFICATION IN FIXED MEDIA TRICKLING FILTERS	2-3
2.5 FIXED BIOFILM MODEL	2-4

<b>TABLE OF CONTENTS</b>	<b>Page</b>
<b>2.6 MASS TRANSFER IN FIXED BIOFILMS</b>	<b>2-5</b>
2.6.1 Oxygen transfer	2-6
2.6.2 Substrate concentration	2-7
2.6.3 Alkalinity limitation	2-8
<b>2.7 OPTIMUM OPERATING CONDITIONS FOR EFFICIENT TERTIARY NITRIFYING TRICKLING FILTER PERFORMANCE</b>	<b>2-ERROR! BOOKMARK NOT DEFINED.</b>
2.7.1 Type of media	2-8
2.7.1.1 Rock media	2-9
2.7.1.2 Plastic media	2-9
2.7.1.3 Media efficiency in the application of tertiary nitrifying trickling filters	2-9
2.7.2 Influent organic concentration	2-10
2.7.3 Influent total suspended solids concentration	2-10
2.7.4 Influent ammonia concentration	2-11
2.7.5 Ventilation	2-12
2.7.6 Hydraulic loading rate	2-12
2.7.7 Ammonia loading (ALR) and nitrification rates (ANR)	2-13
2.7.8 Predation	2-14
2.7.8.1 Filter fly larvae	2-14
2.7.8.2 Worms	2-15
2.7.8.3 Snails	2-15
2.7.9 The effect of wastewater temperature	2-16
2.7.10 Two- stage operation of nitrifying trickling filters	2-17
<b>2.8 NITRIFICATION RATES IN TERTIARY NITRIFYING TRICKLING FILTERS</b>	<b>2-19</b>
<b>2.9 SUMMARY</b>	<b>2-21</b>

TABLE OF CONTENTS	Page
<b>CHAPTER 3: PRELIMINARY FULL-SCALE NITRIFYING TRICKLING FILTER PERFORMANCE</b>	
3.1 INTRODUCTION	3-1
3.2 BACKGROUND TO THE OPERATION OF THE CITRUSDAL WASTEWATER TREATMENT PLANT (CWWTP)	3-1
3.2.1 Treatment plant layout	3-2
3.2.2 Lagoon operation	3-3
3.2.3 Nitrifying trickling filter	3-3
3.3 INITIAL FINDINGS	3-4
3.4 INITIAL RECOMMENDATIONS FROM THE 2001 INVESTIGATION	3-5
3.5 IMPLEMENTATION OF RECOMMENDATIONS	3-6
3.5.1 Aerated lagoon	3-6
3.5.2 Nitrifying trickling filter	3-6
3.5.2.1 Forced ventilation	3-6
3.5.2.2 Sampling ports	3-7
3.5.2.3 Flow distribution	3-7
3.5.2.4 Recycle of effluent	3-8
3.5.2.5 Flow measurement devices	3-8
3.6 PRELIMINARY RESULTS OF THE PERIOD BETWEEN 2001 -2005	3-8
3.6.1 Internal performance	3-10
3.7 FINAL RECOMMENDATIONS	3-11

<b>TABLE OF CONTENTS</b>	<b>Page</b>
--------------------------	-------------

<b>CHAPTER 4: METHOD OF INVESTIGATION</b>	
---	--

<b>4.1 INTRODUCTION</b>	<b>4-1</b>
<b>4.2 FULL-SCALE INVESTIGATION</b>	<b>4-1</b>
<b>4.2.1 Sample collection</b>	<b>4-2</b>
4.2.1.1 Sample preservation	4-2
<b>4.2.2 Profile sample collection</b>	<b>4-3</b>
<b>4.2.3 Profile sampling</b>	<b>4-3</b>
4.2.3.1 Method of evaluation	4-3
<b>4.2.4 Sample analysis</b>	<b>4-4</b>
<b>4.2.5 Flow measurement</b>	<b>4-5</b>
<b>4.3 DESIGN AND START-UP OF THE LABORATORY SCALE NTF</b>	<b>4-5</b>
4.3.1.1 Flow distribution	4-6
4.3.1.2 Media density	4-6
4.3.1.3 Ventilation	4-7
4.3.1.4 Treated wastewater	4-7
4.3.1.5 Ammonia dosing	4-7
4.3.1.6 Alkalinity	4-7
4.3.1.7 Temperature	4-7
4.3.1.8 Laboratory scale NTF start-up	4-8
<b>4.3.2 Sample analysis</b>	<b>4-8</b>

## TABLE OF CONTENTS

Page

### CHAPTER 5: RESULTS AND DISCUSSIONS ON THE FULL SCALE NITRIFYING TRICKLING FILTER PERFORMANCE

5.1	OVERVIEW OF THE NITRIFYING PERFORMANCE DURING THE INVESTIGATION	
	PERIOD	5-1
5.1.1	Overview of the influent organic loading on the nitrifying trickling filter	5-4
5.1.2	Effect of increased hydraulic loading on the nitrifying performance	5-6
5.1.3	Overview of the internal ammonia profile of the nitrifying trickling filter	5-8
5.2	INTERNAL BEHAVIOUR OF THE NITRIFYING TRICKLING FILTER	5-12
5.2.1	Media wetting	5-12
5.2.2	Microbial analysis of the profile samples	5-14
5.2.3	Predator proliferation	5-16
5.3	PERFORMANCE OF THE NTF DURING SELECTED OPERATING PERIODS	5-16
5.3.1	Performance of the nitrifying trickling filter during Period I-A	5-17
5.3.1.1	Influent organic loading rate during Period I-A	5-18
5.3.2	Performance of the nitrifying trickling filter during Period II-A	5-19
5.3.2.1	Influent organic loading rate during Period II-A	5-20
5.3.3	Performance of the nitrifying trickling filter during Period II-B&C	5-21
5.3.3.1	Influent organic loading rates during Periods II B&C	5-24
5.3.4	Nitrogen balance over the full-scale investigation period	5-25
5.3.5	Internal ammonia removal performance of the individual faces of the nitrifying trickling filter	5-26
5.3.5.1	Internal performance of the West face	5-26
5.3.5.2	Internal performance of the East face	5-27

<b>TABLE OF CONTENTS</b>	<b>Page</b>
<b>CHAPTER 5: RESULTS AND DISCUSSIONS ON THE FULL SCALE NITRIFYING TRICKLING FILTER PERFORMANCE</b>	
5.3.5.3 Internal performance of the South face	5-28
5.3.5.4 Internal performance of the North face	5-29
5.4 INTERNAL NITRIFICATION RATES OF THE FULL-SCALE NITRIFYING TRICKLING FILTER	5-30
5.5 CONCLUSIONS	5-32
<b>CHAPTER 6: APPARENT NITRIFYING PERFORMANCE OF THE LABORATORY-SCALE NITRIFYING TRICKLING FILTER</b>	
6.1 START-UP NITRIFYING TRICKLING FILTER PERFORMANCE	6-1
6.2 THE EFFECT OF INCREASED HYDRAULIC LOADING RATES ON THE NITRIFYING PERFORMANCE	6-3
6.3 NITRIFYING TRICKLING FILTER PERFORMANCE UNDER SOLUBLE ORGANIC LOADING RATES	6-6
6.4 NITROGEN BALANCE	6-7
6.5 COMPARISON OF THE INVESTIGATION RESULTS WITH LITERATURE	6-9
6.6 CONCLUSIONS	6-11

**TABLE OF CONTENTS** **Page**

**CHAPTER 7: CONCLUSIONS AND RECOMMENDATIONS**

<b>7.1</b>	<b>FULL-SCALE INVESTIGATION CONCLUSIONS</b>	<b>7-1</b>
7.1.1	apparent ammonia nitrification rates	7-1
7.1.2	The effect of organic loading rates on apparent ammonia nitrification rates	7-2
7.1.3	The effect of the hydraulic loading rates on apparent ammonia nitrification rates	7-2
7.1.4	Ventilation	7-3
7.1.5	Internal nitrifying performance of the full-scale ntf	7-3
7.1.6	Structural design of the Citrusdal nitrifying trickling filter	7-4
<b>7.2</b>	<b>LABORATORY-SCALE INVESTIGATION CONCLUSIONS</b>	<b>7-4</b>
7.2.1	Apparent ammonia nitrification rates	7-4
7.2.2	Effect of organic loading rates on apparent ammonia nitrification rates	7-4
7.2.3	The effect of hydraulic loading rates on apparent ammonia nitrification rates	7-5
<b>7.3</b>	<b>RECOMMENDATIONS</b>	<b>7-5</b>

**8. REFERENCES**

**APPENDICES**

**APPENDIX A: LITERATURE REVIEW - NITRIFYING TRICKLING FILTER MODELS**

**APPENDIX B: SUMMARY OF SITE DIARIES**

**APPENDIX C: EFFLUENT RECIRCULATION SYSTEM**

**APPENDIX D: FULL-SCALE FLOW MEASUREMENT**

**APPENDIX E: FULL-SCALE NITRIFYING TRICKLING FILTER PROFILE SUMMARY**



## LIST OF FIGURES AND TABLES

Page

### CHAPTER 1: INTRODUCTION: EXTERNAL NITRIFICATION OF LAGOON EFFLEUNT IN A TERTIARY NITRIFYING TRICKLING FILTER – FULL SCALE INVESTIGATION

Figure 1.1: Conventional integration of TFs with BNRAS systems	1-2
Figure 1.2: Proposed integration of trickling filters with BNRAS to achieve ENBRAS	1-3

### CHAPTER 2: LITERATURE REVIEW

Figure 2.1: Potential substrate profiles within the biofilm	2-5
Figure 2.2: Definition of hydraulic loading rate (HLR), ammonia loading rate (ALR), apparent ammonia nitrification rate ( $A_p$ ANR) and actual ammonia nitrification rate ( $A_c$ ANR)	2-13
Table 2.1: NTF experimental performance (Parker <i>et al.</i> , 1995)	2-17
Figure 2.3: Single-stage operation nitrification rates as function of depth	2-18
Figure 2.4: Two-stage operation nitrification rates as function of depth	2-18
Table 2.2: Summary of maximum nitrification rates published in the literature reviewed	2-20

### CHAPTER 3: PRELIMINARY FULL-SCALE NITRIFYING TRICKLING FILTER PERFORMANCE

Figure 3.1: Schematic layout of the Citrusdal Wastewater Treatment Plant	3-2
Table 3.1: Initial analysis of NTF (Muller <i>et al.</i> , 2004 unpublished)	3-4
Figure 3.2: Typical NTF side wall as at 2007	3-7
Figure 3.3: Influent flow distribution network of the NTF	3-8
Table 3.2: Initial apparent nitrification removal efficiency (Adapted from Mofokeng thesis 2006)	3-9
Figure 3.4: Average* NTF Profile Performance before the installation of NTF effluent recycle (*Average of ammonia concentrations taken from all the 4 NTF faces at the same depth)	3-10

### CHAPTER 4: METHOD OF INVESTIGATION

Figure 4.1: Schematic diagram of laboratory scale NTF set up	4-5
Figure 4.2: Cross section of the distribution disc	4-6
Table 4.1: Reactor density ratio experiment results	4-6

## LIST OF FIGURES AND TABLES

Page

### CHAPTER 5: RESULTS AND DISCUSSIONS ON THE FULL SCALE NITRIFYING TRICKLING FILTER PERFORMANCE

Table 5.1	Average ambient maximum and minimum air temperatures and rainfall data during the full-scale investigation period	5-2 5-2
Figure 5.1:	Apparent ammonia nitrification rate (ApANR) performance of the trickling filter during the investigation period (20/02/06 – 30/09/07)	5-2
Table 5.2:	Summary of the apparent ammonia nitrification rates of the NTF during the investigation period from February 2006 to September 2007	5-3
Figure 5.2a:	Influent and effluent soluble COD concentrations and associated organic removal rates during the summer period 2006 and 2007	5-4
Figure 5.2b:	Influent and effluent soluble COD concentrations and associated organic removal during the winter period 2006 and 2007	5-5
Figure 5.2c:	Influent and effluent soluble COD concentrations and associated organic removal during the summer period 2006 and 2007	5-5
Figure 5.2d:	Influent and effluent particulate COD concentrations and associated organic removal during the winter period 2006 and 2007	5-6
Table 5.3:	Trickling filter recirculation pumps inventory during the investigation period of the research	5-7 5-7
Figure 5.3:	Effect of the hydraulic loading rate (HLR) on the apparent ammonia nitrifying performance of the trickling filter (20/02/06 – 30/09/07)	5-8
Figure 5.4:	Diagram of the East and South faces of the Citrusdal trickling filter	5-9
Figure 5.5:	Average internal ammonia concentration profile of the nitrifying trickling filter during the investigation summer period	5-10
Table 5.4:	Apparent ammonia nitrification rate of the NTF with 2 of the 4 forced air ventilation fans in operation	5-10
Figure 5.6:	Average internal ammonia concentration profile of the nitrifying trickling filter during the investigation winter period	5-11 5-11
Figure 5.7:	Profile sample positions along the NTF media depth	5-12
Figure 5.8:	Influent flow distribution network of the NTF	5-13
Figure 5.9:	A summary of the media wetting through East and South faces	5-13
Figure 5.10:	A summary of the wetting rate through West and North faces	5-14
Figure 5.11:	Leaking on the North face during the investigation period	5-15
Table 5.5:	Operating parameters during Period I-A	5-17
Figure 5.12:	Average internal ammonia concentration profile of the nitrifying trickling filter during Period I-A	5-18 5-18
Figure 5.13:	Total (includes soluble and particulate) organic loading and removal rates and apparent ammonia nitrification rates during Period I-A	5-19

## LIST OF FIGURES AND TABLES

Page

### CHAPTER 5: RESULTS AND DISCUSSIONS ON THE FULL SCALE NITRIFYING TRICKLING FILTER PERFORMANCE

Table 5.6:	Operating parameters during Period II-A	5-20
Figure 5.14:	Effect of the ammonia loading rate on the ammonia nitrification rate of the trickling filter Period II-A	5-20
Figure 5.15:	Total influent organic loading rates and organic removal rates and the apparent ammonia nitrification rates of the trickling filter during Period II-A	5-21
Table 5.7:	Operating parameters during Periods II-B&C	5-22
Figure 5.16:	Effect of the ammonia loading rate on the apparent ammonia nitrifying performance of the trickling filter during Periods II B&C	5-22
Figure 5.17:	Internal ammonia concentration profile of the nitrifying trickling filter during Periods II B&C	5-23
Figure 5.18:	Total influent organic loading rates and organic removal rates and the apparent nitrification rates of the trickling filter during Periods II-B&C	5-23
Table 5.8	Full- scale nitrogen balance on the NTF performance during the investigation period	5-25
Figure 5.19:	Internal ammonia concentration profile of the West face during the winter period	5-27
Figure 5.20:	Internal ammonia concentration profile of the East face during the winter period	5-28
Figure 5.21:	Internal ammonia concentration profile of the South face during the winter period	5-29
Figure 5.22:	Internal ammonia concentration profile of the North face during the winter period	5-29
Figure 5.23:	Internal trickling filter media sections associated with actual nitrification rates	5-30
Figure 5.24:	Internal ammonia nitrification rates during the investigation period	5-31
Table 5.9:	The effect of organic removal rates on actual internal ammonia nitrification rates	5-32

### CHAPTER 6: APPARENT NITRIFYING PERFORMANCE OF THE LABORATORY-SCALE NITRIFYING TRICKLING FILTER

Table 6.1:	Ammonia dosing calculation	6-2
Table 6.2:	Operating parameters during the start-up period of the laboratory-scale NTF	6-2
Table 6.3:	Performance of the laboratory-scale NTF under different experimental periods	6-3
Figure 6.1:	Effect of the hydraulic loading rate on apparent ammonia nitrification rates at laboratory-scale	6-4
Figure 6.2:	Effect of the ammonia loading rate on apparent ammonia nitrification rates during the investigation period	6-5
Table 6.4:	Ammonia concentrations through the laboratory-scale nitrifying trickling filter during Period1,2 and 3	6-5
Figure 6.3:	Apparent ammonia nitrification rates of the laboratory-scale nitrifying trickling filter (April to August 2007)	6-6

**CHAPTER 6: APPARENT NITRIFYING PERFORMANCE OF THE LABORATORY-SCALE NITRIFYING TRICKLING FILTER**

Table 6.5:	Performance of the laboratory-scale NTF under different experimental periods	6-7
Table 6.6:	Nitrogen balance on the laboratory-scale performance during the experimental period	6-8
Table 6.7:	Comparison of the optimal operating conditions found in literature and laboratory- and full-scale results of this research	6-10

University of Cape Town