

AN INVESTIGATION INTO THE ATTAINMENT  
OF SPATIAL CONCEPTS BY UNIVERSITY  
SCIENCE STUDENTS

A thesis submitted to the  
University of Cape Town  
in fulfilment of the requirements  
for the degree of  
DOCTOR OF PHILOSOPHY

by

KEVIN ROCHFORD

B.Sc. (Melbourne), B.Ed. (Cape Town), M.Ed. (Cape Town)

Teaching Methods Unit  
University of Cape Town  
Rondebosch, 7700  
Republic of South Africa

August 1984

The University of Cape Town has been given  
the right to reproduce this thesis in whole  
or in part. Copyright is held by the author.

## ACKNOWLEDGEMENTS

My supervisor, Professor J H F Meyer, for his excellent guidance, incisiveness, patience and understanding.

The following members of staff of the University of Cape Town, whose willing support, interest and co-operation enabled the investigation to proceed:

Professor M J Ashley, Department of Education  
Professor E N Keen, Department of Anatomy  
Dr M Fredman, Department of Anatomy  
The late Professor D McKenzie, Faculty of Medicine  
Professor A P Fairall, Department of Astronomy  
Dr D O'Donoghue, Department of Astronomy  
Professor J B Martin, Faculty of Engineering  
Mr A Sass, Department of Mechanical Engineering  
The late Mr B MacKenzie, Faculty of Engineering  
Professor R E Kirsch, Faculty of Medicine  
Professor L S Gillis, Faculty of Medicine  
Professor J V O Reid, Deputy Principal  
Professor D Carr, Deputy Principal  
Dr P A T Wild, Head of Research Administration, and supporting staff  
Professor P E Spargo, Department of Education,  
Professor I de V Heyns, Department of Education,  
Miss C Osborn, Department of Psychology  
Mrs R Donovan, Miss I Waddington, Mrs G Dekker, Mr A Fisher  
and Mr D Paulse, Department of Education  
Mr W P Hirst, Department of Astronomy

Dr M G Cooper, Radiologist

Dr J M Taylor, Council for Scientific and Industrial Research

Mrs J Jenkins, Typist

Mrs A Lloyd, who typed the word-processed manuscript so cheerfully, promptly and efficiently.

The National Foundation for Education Research, U K, who supplied NFER Spatial Test 3.

The financial assistance of both the University of Cape Town and the Human Sciences Research Council towards the costs of this research is hereby acknowledged. Opinions expressed or conclusions reached are those of the author, and are not to be regarded as a reflection of the opinions and conclusions of the Human Sciences Research Council.

Mr P Abrunhosa, Teaching Methods Unit

The British Council

Mr J Newmarch and Mr P Hurley, UCT Computer Centre

Mr D G Perold and Mr P H Boshoff

The regression analyses and tests for normality of data recorded in this investigation were carried out by Professor L.G. Underhill, Department of Mathematical Statistics, University of Cape Town, and by Miss W Milroy. All other statistical work was performed by the author.

My sister, Mrs P Hudson, for her financial assistance and constant personal encouragement.

My parents, both long since deceased, who sacrificed so much to enable me to complete my basic education in faith and with a vision for the future.

My wife, Adelle, and aunt, Sr M Kevin, for their prayerful support and encouragement.

---

This work is dedicated firstly to God who enabled the investigations to proceed and succeed in untold miraculous ways; and secondly to my two infants, Jenna-Lee and Lynden who, together, have provided the inspiration for the existence and ultimate completion of this work.

---

The University of Cape Town has been given the right to reproduce this thesis in whole or in part. Copyright is held by the author.

## LIST OF TABLES

<u>TABLE NO.</u>		<u>PAGE</u>
1.1	(a) An example of a multiple choice question which does not require spatial thinking.	14
	(b) An example of a spatial anatomical MCQ which requires spatial thinking.	
	(c) A further example of a spatial anatomical MCQ which requires spatial thinking.	
1.2	An example of the consistently contrasting performances on spatial and non-spatial examinations of two apparently equally motivated but spatially opposite anatomy students in 1981.	15
3.1	Normal probability plot for the standardized residuals of the data for <u>POPULATION II</u> .	77
3.2	The practical anatomical measures, geometric spatial measures, anatomical spatial measures and non-spatial anatomical measures taken with anatomy students at the University of Cape Town in 1980 and 1981.	84
4.1	t-test results for the differences in performance on practical examinations, essays and the Fredman Test of the 1980 ( <u>POPULATION I</u> ) anatomy students who were failing by mid-year but who were spatial opposites in August, according to the battery of geometric spatial exercises.	97
4.2	t-test results for the differences in performance on spatial and non-spatial MCQs of the 1980 ( <u>POPULATION I</u> ) anatomy students who were failing by mid-year but who were spatial opposites according to the battery of geometric spatial exercises given during interviews in August, 1980.	98
4.3	Corpair correlation matrix for the scores of 38 interviewed students in 1980 ( <u>POPULATION I</u> ).	100
4.4	t-test results for the differences in performance on practical examinations, essays, non-spatial MCQs and the battery of spatial exercises of 25 of the 1980 <u>POPULATION I</u> anatomy students who were failing by mid-year, and who recorded persistent MCQ spatial deficits in every MCQ examination which averaged at least 7% for the whole year.	103

4.5	t-test results for the differences in performance on subsequent practical examinations, essays, spatial MCQs and non-spatial MCQs of the 1981 ( <u>POPULATION II</u> ) anatomy students who were spatial opposites in February according to the battery of spatial exercises.	108
4.6	t-test results for the differences in performance on practical examinations, essays and non-spatial MCQs of the 25 1981 anatomy students from <u>POPULATION II</u> who always score higher on spatial MCQs ( <u>CONTROL GROUP</u> ) and the 1981 anatomy students who record persistent MCQ spatial deficits in both June and November which average at least 8% (Group IIA), 9% (Group IIB), 16% (Group IIC) and 18% (Group IID) over the year.	112
4.7	Corpair correlation matrix for the scores of 37 students in <u>POPULATION II</u> who failed the battery of spatial exercises at the commencement of their course in anatomy in 1981.	113
4.8	The relationship between the number of different sketching errors and omissions in two spatial exercises completed by 139 novice second-year anatomy students ( <u>POPULATION II</u> ) in February 1981 and their subsequent performances in practical examinations in April, June and November.	115
4.9	Results of the geometric spatial testing of <u>POPULATION III(R)</u> in August 1983.	116
4.10	A comparison of the performances on the April and June 1983 examinations of the geometrically spatially able and the geometrically spatially handicapped anatomy students constituting <u>POPULATION III(R)</u> .	118
4.11	Results of the geometric spatial testing of <u>POPULATION IV</u> in August 1983.	121
4.12	Differences between geometrically spatially able and geometrically spatially weak novice anatomy students who were mid-year failures in 1983 ( <u>POPULATION IV</u> ) with regard to mean performances on essay, MCQ and practical examinations.	122
4.13	A comparison of the ultimate fates of the geometrically spatially able and the geometrically spatially weak novice anatomy students who were mid-year failures in 1983 ( <u>POPULATION IV</u> ).	124

4.14	Declining predictive correlation coefficients of different spatial tests and examinations in anatomy.	131
4.15	Empirical data relevant to CASE STUDIES 1 and 2.	136
4.16	Empirical data relevant to CASE STUDIES 3 and 4.	138
4.17	Empirical data relevant to CASE STUDIES 5 and 6.	140
4.18	Empirical data relevant to CASE STUDY 7.	142
4.19	Mean percentage recorded on the first semester class examination by the spatially handicapped and the spatially borderline sub-groups of <u>POPULATION VI</u> relative to the spatially competent sub-group of <u>POPULATION VI</u> using the geometric spatial battery given in March and the Novice Astronomical Spatial Test given in March as the criteria for spatial competence.	148
4.20	Correlations between the scores obtained by <u>POPULATION VI</u>	149
4.21	Results of the regression analysis performed on the dependent and independent variables for <u>POPULATION VI</u> .	152
4.22	Correlations between the scores obtained by <u>POPULATION VII</u> on the tests and examinations in astronomy and the November and December spatial batteries.	155
4.23	Mean percentage drops recorded on tests and examinations in astronomy by the spatially handicapped sub-group of <u>POPULATION VII</u> relative to the spatially competent sub-group of <u>POPULATION VII</u> using the full November Astronomical Spatial Test as the criterion for separating the two groups.	157
4.24	The effectiveness of the UCT March 1983 spatial battery for predicting the June 1983 engineering drawing test results, with the class divided into sixths according to decreasing March spatial performance.	163
4.25	The effectiveness of the UCT March 1983 spatial battery for predicting the November 1983 engineering drawing examination results, with the class divided into sixths according to decreasing March spatial performance.	164

4.26 (i)	Relationships between failing performance in the June engineering drawing examination and (a) below average performance in matriculation mathematics; and (b) outright failure on the March spatial battery.	168
4.26(ii)	Relationships between failing performance in the November engineering drawing examination and (a) below average performance in matriculation mathematics; and (b) outright failure on the March spatial battery.	168
4.27	Correlation matrix for the 185 engineering drawing students with complete data for 1983.	170
4.28	Results of the regression analysis on the intact scores of 185 engineering students using only spatial test score as the independent variable.	172
4.29	Results of the regression on the intact scores of 185 engineering drawing students using all three independent variables.	173
4.30	Random variations in the predictive validity coefficient of the March 1983 spatial battery ( $r=0.65$ ; $N = 273$ for the June 1983 engineering drawing test results), which result when the 273 students are sub-divided alphabetically into groups of 24.	178
I.1	Properties of the geometric spatial battery for the different populations : means, ranges and SD's - <u>APPENDIX I</u>	
I.2	Pass marks set for the four sub-tests of the refined geometric spatial battery - <u>APPENDIX I</u> .	
I.3	Intercorrelation amongst the sub-tests of the geometric spatial battery for <u>POPULATIONS I AND II</u> - <u>APPENDIX I</u> .	

LIST OF FIGURES

<u>FIGURE NO.</u>		<u>PAGE</u>
4.1	A sample item from the geometric spatial battery sub-test "Rotation and Visualization in Three Dimensions".	144

### LIST OF ABBREVIATIONS

DAT	Differential Aptitude Test
DAT-PMAT	Dental Admissions Test - Perceptual Motor Ability Test
ETS	Educational Testing Service
FR	Fail, repeat the whole year
FS	Fail, supplementary examination granted
GFT	Gottschaldt Figures Test
MCQ	Multiple Choice Question
N	Number of subjects in a population or sample
NFER	National Foundation for Educational Research
p	Probability
r	Product moment correlation coefficient
RC	Rotation of Cubes in space
RFT	Rod and Frame Test
RMPBFT	Revised Minnesota Paper Form Board Test
RV	Rotation and Visualization and juxtaposition of geometric objects in three dimensions
SEC	Sectioning of geometric solids
SYN	Synthesis of sections of common geometric solids

INDEX WORDS

Science students  
Science achievement  
University science achievement  
Tertiary science teaching  
Spatial visualization  
Three-dimensional  
Anatomy instruction  
Astronomy instruction  
Engineering drawing instruction  
Mechanical drawing instruction  
Science education  
Remedial science teaching  
Medical students.

AN INVESTIGATION INTO THE ATTAINMENT OF SPATIAL CONCEPTS BY  
UNIVERSITY SCIENCE STUDENTS

A B S T R A C T

This investigation sought answers to three main questions :

1. Irrespective of level of performance in undergraduate anatomy, descriptive astronomy or engineering drawing, do students with poor spatial visualization ability significantly under-achieve in university class examinations in these subjects relative to their spatially competent peers? If this is the case:
2. Can a battery of spatial exercises be employed to diagnose severe three-dimensional impairment amongst students failing in anatomy, descriptive astronomy and engineering drawing and, if so, what is the optimum composition of such a battery?
3. For the purposes of counselling and possible remedial teaching, at which stage during a course of university study should failing students be tested for suspected spatial ineptitude?

The investigation from 1980 to 1983 involved four populations of anatomy students, three populations of astronomy students, one year of engineering students and one group of clinical remedial mathematics students. The academic performances of 1126 students were monitored during this period, and 621 of these students were singled out for special measurement of spatial achievement in their academic subjects.

Geometric spatial ability was measured using a battery of three-dimensional exercises involving the sectioning, joining, translation, rotation and visualization of solid objects.

Anatomical spatial achievement was measured regularly three times per year using university practical examination scores, as well as the students' scores on MCQ anatomy examinations which were classified as three-dimensional by a panel of lecturers in anatomy.

Non-spatial anatomical achievement was measured using the university essay examination scores, together with students' scores on non-spatial items in the MCQ anatomy examinations.

Astronomical spatial proficiency was measured using author-constructed tests of visualization in three dimensions with respect to the positions and movements of heavenly bodies.

The data were analyzed using t-tests, chi-squared tests, correlations and regression analysis. The results showed that spatial ability plays a statistically significant role in determining student performance on examinations in anatomy, descriptive astronomy and engineering drawing. Tests of anatomical spatial proficiency and of astronomical spatial proficiency were found to be much better predictors of academic success than traditional geometrically-based tests of spatial ability. Spatially inept students tended to under-achieve significantly in certain descriptive astronomy examinations (by about 8%), in practical anatomy examinations (by 10% to 20%) and in engineering drawing (by more than 20%), on the average. The spatial measures in anatomy were found to be most powerful when used as mid-year diagnostic instruments rather than as early predictors of academic achievement but, in engineering drawing, they were most effective when administered at the commencement of the course.

The evidence suggests that spatial skills are acquired by most science students during the normal course of their university studies, but that about 2% of students remain grossly permanently spatially disabled, even when repeating a spatially-orientated subject in the year immediately following their outright failure in that subject.

## CONTENTS

	<u>PAGE</u>
ACKNOWLEDGEMENTS	i
LIST OF TABLES	iii
LIST OF FIGURES	vii
LIST OF ABBREVIATIONS	viii
INDEX WORDS	ix
ABSTRACT	x
<u>CHAPTER 1 - THE ORIGINS AND CONTEXT OF THE THESIS RESEARCH</u>	1
Origin and Background of the Problem	1
The Purposes of the Investigation and Statement of the Problem	3
The Nature of the Problem	5
Delimitation of the Problem	9
The Importance of the Problem	10
The Importance of Innovative Technique in Solving the Problem	12
Clarification of Terms	16
Hypotheses	18
Procedure	20
Procedure for the Treatment of the Data	22
Organization of the Remainder of the Thesis	22
Summary of the Chapter	24
<u>CHAPTER 2 - REVIEW OF RELATED LITERATURE</u>	26
A. <u>CONCEPT LEARNING AND SPATIAL VISUALIZATION ABILITY</u>	27
The Nature of Concept Learning	27
The Value of Concept Learning in the Study of Science	32
The Relationship between Learning Concepts in Science and Spatial Visualization	32

	Spatial Visualization as a Primary Mental Ability	35
	The Components of Cognition and Factor Structure of Spatial Visualization Ability	37
	Conclusions that can be drawn about Concept Learning and Spatial Ability in Science	44
	Unanswered Questions and Assumptions arising from the Literature Survey	45
B.	<u>PREVIOUS STUDIES ON THE RELATIONSHIP BETWEEN SPATIAL VISUALIZATION ABILITY AND ACADEMIC SUCCESS</u>	46
	In Medicine and Dentistry	46
	In Astronomy	48
	In Engineering Drawing	52
	Conclusions that can be drawn about the Relationship between Spatial Visualization Ability and Academic Success	58
	Assumptions and Unanswered Questions arising from the Literature Survey	60
C.	<u>STUDIES ON POSSIBLE CAUSES OF SPATIAL INEPTITUDE</u>	62
D.	<u>INVESTIGATIONS UTILIZING SPECIAL TEACHING OR REMEDIAL METHODS FOR STUDENTS DEFICIENT IN THREE-DIMENSIONAL VISUAL PERCEPTION</u>	65
	Conclusions that can be drawn	67
	<u>CHAPTER 3 - EXPERIMENTAL DESIGN, SAMPLE, CRITERION AND PREDICTORS</u>	69
	The Setting for the Investigation	69
	The Populations Selected	70
	Selection of Research Methods	73
	The Design, Development, Refinement and Properties of the Author-constructed Geometric Spatial Battery	73
	Format of the Statistical Analysis	76

<u>EXPERIMENTAL DESIGN SPECIFIC TO ANATOMY</u>	81
Hypotheses	81
Selection of the Criterion Scores and the Predictors	85
Programme Rationale, Execution and Data Collection	85
<u>EXPERIMENTAL DESIGN SPECIFIC TO ASTRONOMY</u>	86
Hypotheses	86
Selection of the Criterion Scores and the Predictors	88
Programme Rationale, Execution and Data Collection	88
<u>EXPERIMENTAL DESIGN SPECIFIC TO ENGINEERING DRAWING</u>	89
Hypotheses	89
Selection of the Criterion Scores and the Predictors	90
Programme Rationale, Execution and Data Collection	90
<u>SUMMARY OF CHAPTER</u>	92
<u>CHAPTER 4 - PRESENTATION AND ANALYSIS OF THE DATA</u>	94
A. <u>RESULTS : ANATOMY</u>	94
The Diagnostic and Predictive Validities of the Measures	95
POPULATION I	
POPULATION II	
POPULATION III(R)	
POPULATION IV	
SUMMARY	
The Discrimination Validities of the Measures	127
The Independence of the Measures	129
Repeating Students	130
Confirmation of Hypotheses	132
Selected Case Studies	134

B.	<u>RESULTS : ASTRONOMY</u>	145
	Exploratory Findings with <u>POPULATION V</u>	145
	The Predictive Validity of the Measures with <u>POPULATION VI</u>	146
	The Diagnostic Validities of the Measures with <u>POPULATION VII</u>	153
	Summary of the Findings with <u>POPULATIONS VI and VII</u>	158
C.	<u>RESULTS : ENGINEERING</u>	161
	The Predictive Validity of the Measures with <u>POPULATION VIII</u>	161
	The Sampling Validity of the Measures	175
	Summary of Findings with <u>POPULATION VIII</u>	177
	<u>CHAPTER 5 - DISCUSSION OF RESULTS</u>	180
	Opening Remarks	180
	Additional Reflections on the Effectiveness of the Geometric Spatial Battery and Subject-based MCQs for Diagnostic and Predictive Purposes	183
	A Critique of the Scientific Model of Investigation Employed in the Present Study	189
	Implications and Recommendations for Future Research	195
	<u>CHAPTER 6 - SUMMARY, CONCLUSIONS AND RECOMMENDATIONS</u>	200
	<u>LIST OF REFERENCES</u>	209
	<u>APPENDICES</u>	

## APPENDICES

- APPENDIX A Examples of sketches made by university anatomy and astronomy students which are indicative of serious perceptual spatial problems
- APPENDIX B Edgar Stones' Schedule for the Teaching of Concepts
- APPENDIX C A concise historical account of attempts to subdivide, classify and amalgamate the sub-divisions of the spatial factor between 1948 and 1964
- APPENDIX D Definitions of seven factors in the ETS Kit of Factor-Referenced Cognitive Tests
- APPENDIX E Correspondence with Educational Testing Service (ETS)
- APPENDIX F The DIPT classification system for spatial tasks
- APPENDIX G Previous studies on the relationship between spatial visualization ability and academic success in physics, chemistry, biology and mathematics
- APPENDIX H A brief account of the findings of recent investigations into the effectiveness of special teaching or remediation methods for students deficient in three-dimensional visual perception
- APPENDIX I The design, development, refinement and properties of the investigator-constructed geometric spatial battery
- APPENDIX J Sample copies of the instruments used with POPULATIONS I to VIII
- The Fredman Synthesis of Anatomical Sections Test
  - Sample examination paper : MCQ Anatomy
  - Sample examination paper : Anatomy Essays
  - Sample examination paper : Descriptive Astronomy
  - The Full Astronomical Spatial Test
  - Sample examination paper : Engineering Drawing.
- APPENDIX K Gross errors made in sketches by students, together with their comments and "explanations"
- APPENDIX L Relationships between anatomical spatial deficits and the number of errors or omissions in students' sketches for POPULATION II
- APPENDIX M Examples of students' spatial misconceptions in astronomy
- APPENDIX N Error analysis of the Full Astronomical Spatial Test.

## CHAPTER ONE

### THE ORIGINS AND CONTEXT OF THE THESIS RESEARCH

#### ORIGIN AND BACKGROUND OF THE PROBLEM

Many researchers have recognized that spatial visualization plays an important role in the learning of science. Apparently the ability to perceive, retain and mentally manipulate objects contributes to successful performance in a wide range of scientific/analytic disciplines. This assumption has been substantiated by many investigations which correlate achievement on pencil-and-paper tests of spatial ability with academic attainment in science courses.

The present study originated with an incidental observation by a lecturer in astronomy at the University of Cape Town. He articulated his concern that many second-year students are unable to visualize and calculate stellar positions in three dimensions given two-dimensional blackboard representations. Another lecturer (in anatomy) concurred that each year certain medical students appear to have poor morphological appreciation. Whether this could be severe enough to cause outright academic failure was unknown. It was also suspected that training in anatomy would help to improve spatial ability.

Eley (1977:62) has suggested that different topic areas in the natural sciences may be differentially dependent upon spatial abilities, and believes it would be worthwhile to engage in detailed task analyses of these different topic areas to determine which amongst them seem most, or least, dependent on some minimal proficiency in spatial abilities. He concluded by suggesting that it would also seem worthwhile to research the degree to which spatial abilities are trainable.

According to Just (1979:1) much is unknown about the exact role of spatial ability in scientific cognitive processes. There is evidence that while high spatial abilities may be an overall predictor of success in science, they are not necessary and sufficient conditions for success in all science courses (Witkin, 1977; Poole & Stanley, 1972).

In a study with college astronomy students, Kelsey (1980) found that the majority of students do not have, and cannot use, the mental structures required to understand the projective spatial relationships involved in astronomical concepts. She concluded that many teaching materials and classroom presentations may be inappropriate for college astronomy students.

In an investigation into the nature of spatial ability and its role in the mathematical problem-solving process with fifth-grade ele-

mentary school pupils, Moses (1977) found that spatial ability is not innate and is modifiable by instruction. Trotty (1977) investigated the improvements in spatial visualization and manipulation of elementary education majors enrolled in a college art course, and found that imagery instruction facilitated higher gains on tests of spatial ability. Gains in art information and art attitude were also significantly related to gains on the DAT<sup>1</sup> and RMPFBT<sup>2</sup> spatial tests.

The background to the present investigation should be seen in the context of the findings of studies such as these.

PURPOSES OF THE INVESTIGATION  
AND STATEMENT OF THE PROBLEM

In an investigation into the factors associated with success in an engineering drawing and design course at the University of the Witwatersrand, Taylor (1980:1) reports that spatial ability does not appear to be strongly related to the results of any of the common matriculation subjects, and that the ability to comprehend

---

FOOTNOTE <sup>1</sup> Differential Aptitude Test

<sup>2</sup> Revised Minnesota Paper Form Board Test

spatial relations varies across a wide spectrum. The Engineering Department estimates that less than five percent of first-year engineering students are completely unable to form visual images of three-dimensional objects. For the purposes of the current study, it is suggested that a similar situation may exist with regard to university anatomy and astronomy students.

The present research seeks answers to questions in five main areas:

1. Irrespective of level of performance in anatomy, descriptive astronomy or engineering drawing, do students with poor spatial visualization ability significantly under-achieve in university class examinations in these subjects, relative to their spatially competent peers? If this is the case :
2. Can a battery of spatial exercises be employed to diagnose severe three-dimensional impairment amongst students failing in anatomy, descriptive astronomy and engineering and, if so, what is the optimum composition of such a battery?
3. For the purposes of counselling and possible remedial teaching, at which stage during a course of university study should failing students be tested for suspected spatial ineptitude? (Such a question assumes a direct, causal relationship between spatial ability and academic success in certain scientific subjects.)

4. If students who are spatially weak commence a university course in anatomy or astronomy, does their spatial performance tend to improve (spontaneously or as an integral part of learning) with increasing exposure to the subject? Do such students achieve three-dimensional visual competence at widely differing rates? Do spatially weak students who fail and repeat their subject, become spatially competent at their second attempt - that is, can spatial ability be learned? Do any students remain grossly spatially disabled over a two year period of university study?
5. Can additional insights be gained into possible causes of handicaps in ability to visualize three-dimensionally?

#### THE NATURE OF THE PROBLEM

A great deal of research has already been conducted into the nature of spatial literacy. Visual perception refers to the ability to make visual sensory stimuli meaningful (Mercer, 1979:265). Its processes involve operations in which elements of visual stimuli are interpreted and organized. Thus, it figures prominently in the educational process.

McCusky (1981) provides extensive evidence to support the hypothesis that the human visual system consists of two principal modes: focal vision and spatial vision. The main function of focal vision is to analyse form and identify objects. Spatial vision is more

holistic; it is the seat of orientation and location processes. This implies that tests of different natures would be required in order to identify university students who experience learning problems stemming from defective focal vision as distinct from learning problems originating in inadequate spatial vision.

Mercer (1979:265-266), Harwell (1982:68-88) and Cosford (1983:1) identify several major components of visual perception. The present investigation makes the assumption that one or more of these different types of visual perception problems may be experienced either singly or in combination by a minority of university science students, and that such disabilities may have a measurable effect on their academic achievement. Visual perception problems may be grouped as follows :

- (a) Visual discrimination problems involve an inability to perceive dominant features in different objects and, thus, to discriminate one object from another. A typical visual discrimination task involves matching various shapes, designs or objects. Students with a problem in this area could experience difficulties with inversions and reversals, with subsequent confusion of symbols or diagrams.
  
- (b) Visual figure-ground problems occur when an object cannot easily be distinguished from its background. Students with

difficulties in this area may experience problems perceiving parts and wholes.

- (c) Visual orientation problems involve position in space. Students with disorders in this area usually record difficulties with spatial relations. The ability to perceive the positions of objects in space in relation to other objects and to the observer is affected.
- (d) Visual form perception problems involve inaccurate two-dimensional representations of three-dimensional objects.
- (e) Visual sequencing problems include omissions, insertions or substitutions of symbols or connecting parts of diagrams by students.
- (f) Visual memory is the ability to recollect the dominant features of a stimulus item or to recall the order of a number of items presented visually. Students with problems in this area may have difficulty recognising geometric objects and symbols accurately.
- (g) Visual constancy problems involve the misinterpretation of changes in size or shape or colour.

- (h) Visual association and visual closure problems occur when a student is unable to identify figures that are presented in fragments, or unable to visualise the missing portion of a partially incomplete object or diagram.

Examples of sketches made by university science students which may indicate the possible occurrence of perceptual difficulties (a) to (h), are reproduced in Appendix A.

Clearly, the existence of these different aspects of visual perception has implications for the number and nature of spatial tests that should be included in a diagnostic battery for use with university science students.

Johnson and Myklebust (1967:248-255) report that, in contrast to their nonverbal visual deficiencies, dyscalculics tend to record verbal abilities ranging from average to exceptionally superior, which may help to explain their occasional admission to universities. Many dyscalculics are deficient in visual-spatial organization, and cannot quickly distinguish differences in shapes, sizes, amounts or lengths. It seems possible that such severely disabled students might even appear from time to time in certain university science courses.

### DELIMITATION OF THE PROBLEM

Although the term "spatial" may apply to objects and concepts in one, two or three dimensions, this investigation is confined almost exclusively to students' visualization in three dimensions.

It is also primarily concerned with valid and reliable methods of identification, rather than methods of remediation of spatial problems. Its chief focus is on the performance of grossly spatially handicapped students who are in danger of failing spatially-orientated courses, despite their satisfactory non-spatial academic achievement in related studies. (Some attention is given, nevertheless, to the association between spatial incompetence and underachievement amongst students whose scholastic performances are above-average in spatially-orientated science courses.)

The present investigation is limited, in the main, to the years 1980-83, and to the studies carried out on four populations of second-year anatomy students, three populations of second-year astronomy students, one population of first-year engineering students, and one population of fourth-year clinical remedial mathematics teachers-in-training, all at the University of Cape Town. It is not a cross-cultural study, nor is it directly concerned with the specific influence of such variables as sex, race, IQ, attitude and motivation on spatial academic achievement. The majority of students involved in the study are of European origin.

THE IMPORTANCE OF THE PROBLEM

Spatial visualization is gradually being recognized as an important factor in scholastic and occupational success, and as a pervasive fundamental mode of thinking (Handler, 1976).

Crowe & Piper (1983:537) have found that freshman community college students who are field independent (spatially competent) and possess a positive attitude toward science score significantly higher on science achievement tests than students who are field dependent and possess a negative attitude towards science. They also point out that few studies have dealt specifically with college students. Baker (1981) reports that amongst undergraduate humanities and science majors, regardless of sex, spatial ability and a positive attitude toward science are factors which influence a choice of career in science.

Siemankowski & MacKnight (1971:23) found that successful college majors in science, mathematics and art performed significantly better on tests of spatial visualization than did non-majors. They also found that successful college physics majors have excellent three-dimensional conceptualization, better than that of any other science, mathematics or art group, while non-science-orientated students were surprisingly inept in this area. This is important because it suggests the possibility of using spatial tests as diagnostic instruments for the early identification of certain science

students who might benefit from specialized supplementary tuition. It also suggests that either spatial ability develops with increasing exposure to science, mathematics and art at university level, or that these courses tend to discriminate against students with spatial visualization which remains inadequate or weak.

Brinkman (1966:178-184) demonstrated that spatial abilities are by no means "fixed", and that suitable remedial work can be effective. On the other hand, Smith (1964:166), the Cambridge Report (1969), and Hill (1970:27), report that spatial abilities do not increase greatly beyond the age of about 15 years. Clarity is needed on this important issue.

In an investigation conducted with English A-level science students and Portuguese first-year university chemistry students, Seddon & Tariq (1982:409) found that in both countries the average level of performance of the students was "far from satisfactory" on a test requiring them to visualize how diagrams of molecules should be drawn after performing a rotation, reflection or inversion on the molecule itself. They also found through factor analysis that the English and Portuguese students set about visualizing the effects of both rotations and reflections in different ways. This finding suggests that a rich field for future investigations may lie within South African universities, with their diversity of local languages and cultural groups.

Cooper & Shepard (1973:172) conclude pertinently when they write "Evidently we still have a way to go before we achieve an adequate characterization of mental images and of mental operations upon mental images". It is hoped that the findings of the present investigation will make an important contribution in this field.

#### THE IMPORTANCE OF INNOVATIVE TECHNIQUE IN SOLVING THE PROBLEM

According to Handler (1976:7008-A), "sound information about ways to develop and to evaluate spatial visualization ability is lacking. The processes used by students in solving complex three-dimensional visualization problems have not been well-documented". It appears that the creation and evaluation of new experimental techniques in the current investigation is warranted.

The first innovation in the present study is the intentional attempt to hold as constant as possible several important variables (age, status, intelligence and level of previous academic achievement) whilst attempting to measure the possible influence of the variable "spatial ability" on the subsequent scholastic performance of several populations of freshman medical students, most of whom are 20 years old, virtually all of whom have passed the Matriculation examination with "A" averages (that is, more than 80%), and all of whom have been keenly selected for each year of intake from amongst some 800 applicants.

The second innovation is the recognition and utilization of the fact that individual test and examination questions in certain university science courses (for example, anatomy, astronomy, surveying and crystallography) can usually be separated dichotomously into items whose answers either depend on effective three-dimensional visualization or are essentially non-spatial in nature. To illustrate this point, examples of spatial and non-spatial multiple choice questions in anatomy from the University of Cape Town April 1980 examination paper are given in Table 1.1. By judiciously monitoring students' spatial and non-spatial achievements as separate variables directly within the context of the particular academic discipline being taught, it is suggested that a more valid documentation of students' spatial progress can be obtained than merely by the repetitious use of geometric batteries of spatial tests throughout the academic year.

When this innovative technique is applied to students of anatomy, a distinctive pattern begins to emerge. Table 1.2 records the results of a typical candidate (Number 1127) who appears to manifest a serious and persistent spatial disability. The contrast with the comparable, but spatially able, student (Number 1101) is immediately apparent. It is not until the performances of these two fellow students are separated into spatial and non-spatial categories, as in Table 1.2, however, that the trends of the individual students -

TABLE 1.1 (a) An example of a multiple choice question which does not require spatial thinking.

(a) Nerve tracts usually classified as commissures include:

1. the cingulum
- 2.\* the corpus callosum
3. ventral spino-thalamic
4. cortico-spinal
5. none of the above.

(b) An example of a spatial anatomical MCQ which requires spatial thinking.

(b) Concerning the action of the trapezius:

1. middle fibres retract the scapula
2. lower fibres elevate the shoulder girdle
3. lower fibres rotate the inferior angle of the scapula laterally
4. both muscles extend (retract) the head
- 5.\* all four statements are correct.

(Select the INCORRECT statement from statements 1 to 4, or choose 5 if all four statements are correct.)

(c) A further example of a spatial anatomical MCQ which requires spatial thinking.

(c) A transverse section of the midbrain at the level of the superior colliculus will show:

1. the substantia nigra
2. the oculomotor nucleus
3. the red nucleus
4. \*the trochlear nerve nucleus
5. all four statements are correct.

(Select the INCORRECT statement from statements 1 to 4, or choose 5 if all four statements are correct.)

TABLE 1.2 An example of the consistently contrasting performances on spatial and non-spatial examinations of two apparently equally motivated but spatially opposite anatomy students in 1981.

(Failing marks are circled.)

STUDENT'S RANDOMISED CODE NUMBER	FEB. SPATIAL BATTERY SCORE (%)	ESSAYS (%)			NON-SPATIAL MCQ SCORES (%)		PRACTICAL EXAMINATION MARKS (%)				SPATIAL MCQ SCORES (%)		FINAL YEAR MARK IN ANATOMY (%)	
		APRIL	JUNE	NOV.	JUNE	NOV.	APRIL	JUNE	OCT.	NOV.	JUNE	NOV.		
1101	97	42	60	55	64	63	75	85	70	58	67	63	58	
1127	48	40	50	56	68	60	20	28	41	38	46	40	50	
		NON-SPATIAL EXAMINING						SPATIAL EXAMINING						
		Both students score equally well, apparently equally motivated.						One student scores consistently well, the other student consistently fails.						

which would otherwise be lost in the conventional class test statistics - begin to emerge clearly and convincingly.

This effective technique is a natural development and refinement of the experimental strategy adopted by Schonberger (1976) in an investigation into the mathematical problem solving abilities of junior high school pupils. She carefully selected mathematical tasks to make three sub-tests of problems differing in amount of spatial or geometric content.

#### CLARIFICATION OF TERMS

Spatial Ability. For the purpose of this investigation, spatial ability is defined as the ability to perceive, retain and recognize (or reproduce) three-dimensional representations of objects in their correct proportions when they are rotated in space, translated, juxtapositioned, projected, sectioned, re-assembled, inverted, re-orientated or verbally described.

Geometric Spatial Proficiency depends on a particular knowledge of the names and shapes of common geometric (as distinct from anatomical) objects.

Anatomical Spatial Proficiency depends on a particular knowledge of the names and three-dimensional properties, characteristics and

relative positions of the various tissues, organs and systems in the human body.

Non-spatial Anatomical Proficiency. Since approximately half of the examining in anatomy at the University of Cape Town requires an element of spatial visualization, and the remainder is non-spatial in nature, a distinction must be made between spatial anatomical performance and non-spatial anatomical performance by medical students.

Astronomical Spatial Proficiency depends on a knowledge of the names, patterns and relative positions, orientations and motions of heavenly bodies, with particular reference to positions and rotations within the setting of spherical geometry.

Non-spatial Astronomical Proficiency is the ability to remember and understand factual astronomical data that is independent of position in space, (for example, the temperatures and chemical compositions of designated stars).

Spatial Orientation measures usually require the subject to rotate mentally a figure in two- or three-dimensional space. Typical paper-and-pencil tests of spatial orientation include the Cubes Comparison Test in which subjects must mentally rotate two or more three-dimensional cubes to determine if they are the same, and the

Card Rotations Test, in which subjects must determine whether irregularly shaped cards have been rotated within a given plane or lifted out of the plane and flipped over.

Spatial Visualization measures generally require the subject to mentally restructure as well as rotate a figure in space. Often the subject is required to visualize an object from a reference frame which is different from that in which it is presented. Typical paper-and-pencil tests of visualization include a Form Board Test in which subjects must visually put together several shaded drawings to form a pre-determined figure, and the Surface Development Test in which a two-dimensional drawing must be mentally cut and folded to make a solid form.

### HYPOTHESES

Specific hypotheses which concern anatomy students only or astronomy students only or engineering students only are listed separately in Chapter 3. The main, broader hypotheses concerning all university science students, irrespective of field of specialization, are as follows :

1. That under-achievement in these scientific courses of study will be significantly related to performance scores on paper-and-pencil tests of geometric spatial ability.

2. That spatial ability will be acquired by a majority of spatially weak students during the course of their mainstream studies in science, but that these spatially disadvantaged students will attain spatial mastery at widely differing rates. A small minority will remain permanently spatially disadvantaged.
  
3. That the predictive validity of paper-and-pencil tests of spatial ability will decrease significantly with increasing time, as spatially inept students who commence courses of science become more spatially competent during their year of studies.
  
4. That a subject-based spatial test constructed within a given scientific discipline will be a significantly better predictor of achievement within that discipline than a merely geometrically-based battery of spatial exercises.
  
5. That a subject-based spatial test constructed within a given scientific discipline will be a significantly better predictor of achievement within that discipline than a subject-based non-spatial test.

## PROCEDURE

The University of Cape Town's academic year commences in February, and final examinations are written in November. In this study batteries of geometric spatial exercises were designed chiefly by the author, in consultation with two qualified teachers of mechanical drawing. These were given to different science classes at different times of the year, but no one class attempted a geometric battery more than once during the period 1980-83. Although the geometric batteries varied slightly from year to year, they had four sub-tests in common. These were designed to measure

1. rotation, visualization and juxtaposition of geometric objects in three dimensions;
2. the identification of diagrams of matching cubes rotated in space;
3. syntheses of sections of common three-dimensional geometric objects; and
4. diagrammatic sectioning of geometric solids.

When the geometric spatial battery was given to novice science classes in February/March, the battery was considered to be chiefly a predictive measure. When the geometric spatial battery was given to science students in August (after the mid-year examinations), the geometric battery was used as both a diagnostic measure in the case of failing students, and as a predictive measure of final examination performance. When the geometric spatial battery was

given to classes in November (after the final examination), it was considered chiefly as a diagnostic instrument.

The validity of the geometric spatial battery as a diagnostic measure was also tested on small numbers of repeating students who had failed anatomy during the previous year. One group was tested in February 1981; the other in August 1983. It was suspected that prolonged exposure to a scientific spatially-orientated academic discipline may reduce the effectiveness of a geometric battery for diagnosing spatial weakness.

Different groups of anatomy students attempted the geometric spatial battery at different times during their studies, viz. at 0 months (February), 6 months (August), 12 months (February of their repeated year), and 18 months (August of their repeated year). Different classes of astronomy students attempted the battery at 0 months (February/March) and at 9 months (November). The engineering students attempted the battery at 0 months (March) only.

In addition to the geometric battery, tests of anatomical spatial ability and astronomical spatial ability were also used as predictive and diagnostic measures at several points during various years. The tests of anatomical spatial ability were constructed by lecturing staff in the Department of Anatomy at the University of

Cape Town. The tests of astronomical spatial ability were constructed by the author.

The design, development, refinement and properties of these various spatial measures are described in detail in Chapter 3.

#### PROCEDURE FOR TREATMENT OF THE DATA

The refinement and treatment of the raw data are also described in detail in Chapter 3. The statistical analysis involved error and discrimination analysis, removal of MCQ inversions and ambiguities, correlational analysis, regression analysis, the use of chi-square and t-tests for significant differences between groups, tests for normality and homoscedasticity of the data, and the use of Fisher's Z-transformation and Fisher's exact probability test to establish statistically significant differences between groups differing in spatial performance.

#### ORGANIZATION OF THE REMAINDER OF THE THESIS

The following chapter begins by reviewing the nature and value of concept learning in science, and its relationship to spatial visualization. A brief, historical review of the factor structure of spatial visualization as a primary mental ability follows, and its implications for concept learning in science are discussed.

A detailed review is made of existing studies on the relationship between spatial visualization ability and academic success in vari-

ous scientific disciplines, and in other academic subjects, and various conclusions are drawn. Studies on possible causes of spatial ineptitude are also mentioned, together with suggestions for specialized remedial teaching techniques for students with disturbances in three-dimensional visual perception.

Chapter 3 deals with the choice of experimental design, selection of the various populations, selection of research methods and measuring instruments, choice of statistical tests, lists of hypotheses for the different populations, selection of criterion scores and predictors, programme execution and data collection, and the refinement, properties and characteristics of the measures.

In Chapter 4 the data are presented and the results analyzed. Chapter 5 is devoted to a discussion of the findings in anatomy, descriptive astronomy and engineering drawing and, finally, in a wider context with particular reference to a critique of the measures, models and modes of investigation employed in the present study, and their implications for further research in this area.

The final chapter summarizes the findings, conclusions and recommendations.

### SUMMARY OF THE CHAPTER

It has been well established that spatial visualization plays an important role in the learning of science, but little is known about the exact role of spatial ability in scientific cognitive processes. Some of the factors which appear to affect the attainment of spatial concepts by university science students include cultural background, sex, race, teaching methods and the duration of instruction.

To date, virtually all investigations into the relationship between spatial ability and academic achievement have been concerned with the performances and achievements of whole classes. Individual failing students, who may be experiencing (and, indeed, may continue to experience) serious spatial learning problems have not been a special focus for study at university level. There appears to be a need for valid and reliable means of identifying the spatial disabilities of such students, particularly if it can be established that spatial incompetence is a statistically significant factor in under-achievement in university science courses such as anatomy, descriptive astronomy and engineering drawing.

The present investigation is believed to be methodologically advanced in that it attempts to hold as constant as possible variables such as IQ, level of academic achievement, age and status

while studying the possible relationship between spatial ability and academic performance in a selected discipline such as anatomy.

The employment of subject-orientated spatial tests in addition to the conventional use of standardised batteries of geometric spatial tests is also believed to be a new methodological advance. Both the spatial and non-spatial performances of individual university science students are monitored for periods of up to two years in a given academic discipline, and different classes within a given subject are investigated over a continuous period of up to four years. More than a thousand students were involved in the study which forms the basis of this thesis research.

## CHAPTER TWO

### REVIEW OF RELATED LITERATURE

The literature review, which provides both the background for, and the theoretical basis of, the investigation is divided into four major sections.

In the first section the theoretical framework necessary for the research is established. It embraces the nature of concept learning, the value of concept learning in the study of science, and the relationship between learning concepts in science and spatial visualization. The importance of spatial visualization as a primary mental ability is described, and its structural components or factors are delineated.

In the second section a review is made of previous studies on the relationship between spatial visualization ability and academic success, with specific reference to courses in dentistry, medicine, astronomy, engineering drawing, chemistry, biology and mathematics.

Studies suggesting possible causes of spatial ineptitude are considered in the third section, and in the fourth section a review is

made of the effectiveness of different specialized techniques for remediating disturbances in three-dimensional visual perception amongst students.

Throughout the literature review conclusions are drawn, and assumptions and unanswered questions arising from the survey are noted.

#### A. CONCEPT LEARNING AND SPATIAL VISUALIZATION ABILITY

##### THE NATURE OF CONCEPT LEARNING

Research into concept learning was stimulated in the 1940s by the work of Smoke (1942) and Heidbreder (1945). Smoke suggested techniques for studying concept formation amongst different groups, and Heidbreder reported the results of a series of studies on concept attainment, much of her work centering on instances of perceptual and verbal presentation of concepts.

Vinacke (1951) made a detailed review of research on concept attainment and, for about 20 years following Vinacke's call for a wider range of experimentation on concept formation, a considerable increase occurred in both the number and variety of investigations. Numerous books on concept learning appeared during this period, and Goodnow, Hunt, Austin, Bruner, Harris and Klausmeier emerged as leading researchers. The

book, A Study of Thinking by Bruner, Goodnow & Austin (1956) has become a definitive work. Concept attainment was defined in terms of the correct classification of objects based on unique sets of dimensions explained by the experimenter.

Dorsey (1978:19-20) points out that a study of the literature on concept formation and related subjects shows that the word 'concept' has not been used with consistency. Under the heading of concept occur such things as learning nonsense words, acquiring new categories of words, the inferring of a new set of objects and even the solving of mathematical puzzles.

Concepts specifically associated with classroom learning, however, have been investigated only relatively recently, for example by Remstad (1967). Subsequently, Joyce & Weil (1972:11-12) tabulated a number of different Models of Teaching which may be employed to enhance concept formation. These include Taba's Inductive Teaching Model; Suchman's Inquiry Training Model; Bruner's Concept Attainment Model; the Developmental Models of Piaget, Sigel and Sullivan; Ausubel's Advance Organizer Model, and Gagné's Conditions of Learning Model.

Ausubel & Robinson (1971:62) define concept formation as "the process of inductively discovering the criterial attributes of a class of stimuli".

More recently, the biologist Novak (1980) has distinguished between a concept and a proposition. Concept is defined as the regularity in events or objects designated by a sign or symbol, whereas propositions are specific relationships between two or more concepts. Propositions gain meaning as the component concepts gain meaning. Concepts grow in meaning as they are related to more and more different concepts in meaningful propositions.

Stones (1979:205-206) has constructed a 12-step SCHEDULE FOR THE TEACHING OF CONCEPTS, and indicates that the last item on his schedule is the acid test of the understanding of concepts. It requires the learner to identify and/or discriminate novel exemplars of the concepts from non-exemplars. Stones' SCHEDULE is reproduced in Appendix B, and is clearly relevant to the teaching and testing of spatial concepts amongst students.

In addition to postulating eight types of general learning, Gagné (1963a; 1963b; 1977) has presented theories of learning by enquiry. He has also formulated theories by which concepts

can be used to improve learning in specific subjects such as mathematics and science. Gagné's system of task analysis forms an essential component of the theoretical framework of the present investigation.

According to the Conceptual Learning and Development Model of Klausmeier, Ghatala and Frayer (1974), there are different levels of concept mastery, and specifiable cognitive operations are needed to attain these levels.

The model discusses not only how to attain these levels, but also explains the conditions of concept attainment itself. Factors affecting concept mastery may be grouped into three categories :

- (a) characteristics of the learner
- (b) characteristics of the instructional situation, and
- (c) characteristics of the concept.

Characteristics of the learner include individual differences such as achievement and cognitive style, as well as the age of the learner. Characteristics of the instructional situation include instructions given before the concept is presented and the manner of presenting the concept. Characteristics of the concept include the number of defining attributes, the nature

of the rule joining the attributes, and the degree of abstraction.

To facilitate concept development, a number of recommendations can be made. These include the use of a rational set of both positive and negative instances, verbal cues concerning relevant attributes, the concept definition with prompting questions related to the definition, synonyms, and sentences using the concept names. In general, providing a combination of these types of information is better than providing a single type. The amount of irrelevant information given should be minimized. Concept instances should be presented simultaneously and ample time should be allowed for study.

From this brief overview of concept learning, it can be provisionally concluded that :

1. There are different levels of concept mastery;
2. Prior to teaching a concept it is important both to ascertain the student's prior knowledge and to carry out a task analysis of the concept;
3. No one 'best' way of enhancing concept formation is known;
4. Concepts grow in meaning as they are related to further concepts;

5. Factors affecting concept attainment are many ; for example, the learner's age and cognitive style and the characteristics of the instructional situation itself;
6. Concepts should be taught in terms of their attributes, and by means of exemplars and non-exemplars;
7. Instances of concepts should be presented simultaneously with ample time allowed for cueing and learning.

#### THE VALUE OF CONCEPT LEARNING IN THE STUDY OF SCIENCE

Voelker & Sorenson (1970) and Ausubel & Robinson (1971) have carried out detailed investigations into the analysis and classification of concepts relevant to the classroom learning of science, particularly at high school level. Piaget (1953) has also carried out extensive studies which centre on the analysis of processes by which young children acquire concepts in mathematics and science. As a result of these studies, there now appears little doubt that concept learning is crucial to learning in science.

#### THE RELATIONSHIP BETWEEN LEARNING CONCEPTS IN SCIENCE AND SPATIAL VISUALIZATION

The ability to judge the relationship of objects in space, to judge shapes and sizes, and to manipulate these objects mentally is generally referred to as spatial visualization abili-

ty. This capacity for perceptual thinking with spatial aspects and relationships of objects has been described as a form of abstract thinking (Weigl, 1941:33).

Many scientific disciplines such as anatomy, chemistry and crystallography have been taught from a structural point of view. The value of structure in the learning of chemistry, for example, was stressed by Floy (1975:1268), the recipient of the 1974 Nobel Prize in Chemistry, when he wrote :

Structural chemistry has provided such a wealth of information that comprehension of spatial relationships between atoms and molecules is a prerequisite if one is to understand this science.

Consequently, it has been particularly important for science students to be able to judge shapes and sizes of objects and the relationship between them in space.

Many of the investigations into visualization and learning for mastery have been associated with military institutions or conducted in primary and secondary schools. The relatively few studies that have taken place at the post-school level have been chiefly in mathematics or engineering (Baker & Talley, 1972:775).

Martin (1966) investigated the extent to which students being trained as mathematics teachers at Washington State University were proficient in spatial visualization abilities, compared with students being trained as teachers of the natural sciences and the social sciences. The results of the study showed:

1. Prospective science teachers scored significantly higher on spatial visualization tests than did prospective teachers in any other areas.
2. Prospective elementary and secondary teachers who had studied advanced courses in mathematics recorded a higher degree of spatial visualization than those with little or no training in mathematics.
3. In general, no significant relationship between scholastic aptitude and spatial visualization was found amongst the 500 students studied.

In a series of well-known studies by Roe (1953), an investigation was carried out into the spatial visualization abilities (amongst others) of outstanding anthropologists, psychologists, and biological and physical scientists. The Princeton Educational Testing Service designed a special battery of tests to be given to these groups. The results of the study showed :

1. Scientists are capable of a high degree of three-dimensional conceptualization.
2. The level of spatial conceptualization varied in each discipline, with physicists showing the highest while the anthropologists were lowest.
3. There was a significant correlation at the one per cent level between age and spatial visualization. In general, those in the lower age bracket, in each group, exhibited the highest degree of spatial visualization skills.

The implications of these findings for the present study are not only that there is a strong relationship between learning concepts in science and spatial visualization ability, but also that conventional, commercially-available tests of spatial ability may be too easy for highly selected university science and medical students. A special battery of spatial exercises may need to be devised for such students.

#### SPATIAL VISUALIZATION AS A PRIMARY MENTAL ABILITY

Until the late 1940s, the mental endowment of children and adults was usually measured and appraised by psychological tests which yielded a single index of intelligence such as the mental age or intelligence quotient. Whilst these psychological tests were of some value in indicating a general mental

capacity, they did not provide a complete profile of this intelligence. Thurstone (1938a, quoted in Dorsey, 1978:26), an early advocate for change in intelligence testing, said

These indices were very useful in estimating the mental endowment of school children. The serious limitation of the IQ as an estimate of mental endowment is that two men may have the same IQ and yet be totally different in the mental abilities that they possess. The fundamental problem in this field is, therefore, to isolate and describe the distinct mental abilities which constitute mental endowment.

As a result of the use of factorial methods during recent years, a number of distinctly different mental abilities have been isolated. Currently the custom is to describe an individual's intelligence in terms of a profile with a rating in each of the separate mental abilities. The mental profile has been found to be more useful than a global score with which to describe the mental ability of a person.

Several of the primary mental abilities are associated with the visualization of objects in space. These are examined in detail in the next section of this chapter. It suffices to say at this stage that many researchers such as Spearman who have worked in the domain of primary mental abilities, have concluded that most individuals who are intelligent are fairly well endowed with spatial visualization ability, but that there are many intelligent people who have poor two- and

three-dimensional appreciation. If such students appear in university science classes, they may experience learning problems severe enough to warrant special attention.

#### THE COMPONENTS OF COGNITION AND FACTOR STRUCTURE OF SPATIAL VISUALIZATION ABILITY

The theory that spatial thought processes constitute an important area of cognition has arisen from several decades of research into the nature of intelligence. The initial part of this literature review places spatial reasoning ability within its historical, developmental context, and concludes with a series of theoretical assumptions on which the present investigation is based.

With a refinement in understanding of the nature and measurement of intelligence has come the recognition of distinct ability factors. Spatial and perceptual reasoning abilities have been separated out from other components of intelligence. This evolution of distinctive cognitive factors contrasts with the once-commonly accepted notion of a single intelligence measure.

Just (1979:6-7) has stated that the first large-scale successful attempts to measure intelligence were developed in France

by Alfred Binet. Working with Theodore Simon, Binet developed tests to measure eleven "faculties" :

1. memory
2. mental imagery
3. imagination
4. attention
5. comprehension
6. suggestibility
7. aesthetic appreciation
8. force of will as indicated by sustained muscular tasks
9. moral sentiments
10. motor skill, and
11. judgements of visual space.

Based on these test results, Binet introduced the concept of "mental age" which implied that intellectual progress develops in a way similar to chronological age. Although Binet claimed that he was measuring 22 faculties, later revisions of his test by Lewis Terman of Stanford University led to the introduction of an Intelligence Quotient or IQ as a means of interpreting the test score.

Perhaps the best known proponent of the general intelligence factor was Charles Spearman (1923), who produced a two-factor

theory of intelligence. He argued that any intellectual activity involves both a general factor "g" which it shares with all other intellectual activities, and a specific factor "s" which, in most cases, it shares with none. Just (1979:7), however, says that it is obvious from Spearman's writings that the "g" factor was clearly predominant and accounted for most of the variance in intelligence test scores.

Soon thereafter, a counter-trend emerged which postulated that intelligence is not a single factor but a multiplicity of factors. Among the researchers advocating this viewpoint was L L Thurstone (1938b) who, in a major work, administered a series of 56 psychological tests to over 200 students at the University of Chicago. Using newly developed factor analytic techniques, Thurstone extracted eight primary factors from the test results. These were

1. number
2. word fluency
3. verbal
4. memory
5. inductive reasoning
6. space
7. perceptual speed, and
8. deductive reasoning.

Educationally this breakdown is of importance. It states that these eight abilities are separable and that, although there are significant correlations amongst the factors, success in one area does not generally imply success in another. Thus we are in a position to determine whether particular abilities may be predictive of success or failure in specialized educational curricula and whether or not any one of these factors can be related to overall academic achievement.

According to Smith (1964:98-100), by 1955, El Koussy had attempted to demonstrate empirically that Thurstone's space factor is, indeed, a subdivision of a broader factor. In addition, he also showed how, during the course of time, this spatial factor had been subdivided into five components. Historically these components were called  $S_1$ ,  $S_2$ ,  $S_3$ , Visualization  $V_z$  and Mental Manipulation  $M_a$ .

Definitions of these symbols, and a full historical account of their origins and subsequent re-classification, subdivision and amalgamation are set out in Appendix C.

Myers (1958) reported that, after 30 years' work on spatial abilities, American psychologists had still not succeeded in clarifying the distinctions between the factors which had been isolated in this field, and that the domain of spatial ability

had not yet been clearly defined. Myers also believed that spatial ability is a wide trait similar in importance to such pervasive traits as verbal intelligence and social intelligence.

Piaget & Inhelder (1956) have stressed that the human's representation of space is built up through the organization of actions performed on objects in space. They suggest that at first these are motor actions and that later they are internalized actions which result in operational systems. Thus spatial ability involves manipulation of the spatial environment, rather than the mere "reading off" of this environment by the perceptual apparatus. This belief, that actions rather than perceptions comprise the essential vehicle for the development of spatial representation, is a cornerstone of Piaget's theory.

Perhaps the most ambitious attempt to factor analyse intelligence as a whole was made by Guilford (1956). In his structure of intellect model, Guilford proposed that there are 120 primary mental abilities, deriving them theoretically from cross-sections of a three-dimensional 5x4x6 matrix. The axes of the matrix he advocated represented

1. processes/operations
2. material/content, and

3. applications of an operation to material or content.

In an attempt to amalgamate much of the literature on factors of intelligence, Ekstrom, French & Harman (1976) of the Educational Testing Service (ETS) produced a "Kit of Factor-Referenced Cognitive Tests". This kit consists of 72 tests which load on 23 factors. Although they have identified 23 factors comprising mental endowment, nevertheless they argue that pure factors are non-existent, and they avoid rigid classification systems such as Guilford's.

Of the 23 factors isolated in the ETS Kit, seven seem to be related to spatial and perceptual abilities. These are

1. flexibility of closure
2. speed of closure
3. visual memory
4. perceptual speed
5. spatial orientation
6. spatial scanning, and
7. visualization.

The ETS manual's definition and explanation of each of these factors is given in Appendix D. Appendix E, however, contains a copy of the letter from ETS indicating a dearth of spatial

tests suitable for use with university anatomy and astronomy students. As a result, the present study utilised author-designed exercises and NFER Spatial Test 3 which is available from the United Kingdom.

Although the ETS manual considers the above seven factors unique, there are a number of studies which conclude that several of the factors are related. These are reviewed by Just (1979:13-14) who points out that the spatial factors flexibility of closure, spatial orientation, and visualization, are often considered intercorrelated, and that the critical component uniting them is the ability to visualize and mentally restructure relationships amongst objects. He concludes that there is still no consensus (in 1979) on the nature of "spatial factors".

Dissatisfied with those conclusions, Wattanawaha & Clements (1982) - after an extensive review of relevant psychological and educational literature, particularly papers on spatial ability by factor analysis, and after consultations with developmental psychologists - developed the DIPT system. This Dimensionality, Internalization, Presentation, Thought Process (DIPT) classification system for spatial questions is an aid for developing a set of spatial questions requiring different kinds of thinking, and is summarized in Appendix F. Investi-

gating sex differences in spatial performance amongst junior high school pupils, the authors conclude that "the DIPT classification system for spatial tasks has great potential for future use by spatial ability researchers". (Page 886).

Based on a logical synthesis of the above literature review, this study will now attempt to draw conclusions about concept learning and spatial ability in science. It will point out unanswered questions and assumptions arising from the literature survey and will list additional assumptions made in the present study with regard to concept learning and spatial visualization.

#### CONCLUSIONS THAT CAN BE DRAWN ABOUT CONCEPT LEARNING AND SPATIAL ABILITY IN SCIENCE

1. Since many scientific disciplines are taught from a structural point of view, it seems particularly important that science students be able to judge the shapes and sizes of objects and the relationship between them in space.
2. The overall level of spatial conceptualization inherent in different branches of science appears to vary from one scientific discipline to another.
3. Young scientists tend to score significantly better on tests of spatial visualization than older scientists.

4. There is a strong relationship between spatial visualization ability and an understanding of scientific concepts in general.
5. There is no single "best" way of enhancing the attainment of spatial concepts by science students.
6. In general, spatial concepts might be taught in terms of their attributes, and by means of exemplars and non-exemplars, in such a way as to link up with the learner's existing knowledge and cognitive style.

#### UNANSWERED QUESTIONS AND ASSUMPTIONS ARISING FROM THE LITERATURE SURVEY

To conclude this section of the literature survey, the present investigation makes the following assumptions based on a logical synthesis of the research cited:

1. Human mental endowment comprises a number of discernably different primary mental abilities which can be at least partially isolated, characterized, described and measured.
2. Several of these primary mental abilities are associated with the visualization of objects in space.
3. Many well qualified, intelligent individuals have poor three-dimensional appreciation, the acquisition of which is trainable.

4. Distinctions between the different spatial factors are not clear-cut. There is still no consensus on the nature of the different factors.
5. For the purpose of this investigation, measures of an individual's "spatial ability" include author-constructed measures of constructs like "flexibility of closure", "visual memory", "spatial orientation" and "visualization" as defined by ETS in Appendix D. These measures, however, do show inter-correlations, and a non-trivial subset of them may fall under a higher-order factor.

**B. PREVIOUS STUDIES ON THE RELATIONSHIP BETWEEN SPATIAL VISUALIZATION ABILITY AND ACADEMIC SUCCESS**

**IN MEDICINE AND DENTISTRY**

In a study of female college students enrolled in various pre-professional courses of study, Osipow (1969) tested the hypothesis that these students will show significant differences on a test of flexibility of closure. Using the Hidden Figures Test, there was a significant F value at the 0.01 level amongst the following groups rank ordered from most field independent (spatially able) through to most field dependent:

1. Dental hygienists
2. Home economists

3. Nurses
4. Special educationists
5. No commitment.

Studying the differences between surgical and psychiatric nursing, Quinlan & Blatt (1972:517) administered the Rod and Frame Test (RFT) to 26 student nurses randomly picked from surgical and psychiatric nursing courses. They found that the RFT and psychiatric grades correlated ( $r=0.55$ ) significantly at the 0.05 level, but that the RFT and surgical grades correlated negatively ( $r=-0.27$ ), but not significantly so. (Higher scorers on the RFT imply greater field dependence or weak spatial appreciation.)

Witkin, et al. (1977) showed that medical students as a group have high spatial abilities, as measured by Witkin's Embedded Figures Test, but this result did not appear to be due to scholastic aptitude.

In an unpublished paper, Goodenough, et al. (1977), researchers at ETS, investigated the relationship between scores on the Embedded Figures Test and specialization in the medical profession. Based on their scores on the spatial test, the medical specialists were classed from most field dependent to most field independent. Rank-ordered from radiology to surgery, internal medicine and psychiatry, the differences be-

tween surgery and psychiatry were significant at the 0.05 level. The authors suggest that long-range prediction about medical career development can be made with some degree of accuracy from knowledge of an individual's cognitive style.

Finally, Just (1979) has recently investigated the relationship between spatial reasoning ability and achievement in a dental school curriculum. He reports that all of the following subjects have a common factor with spatial reasoning ability : orthodontics, endodontics, operative dentistry and dental school grades, as well as overall academic success on the average score in all the scientific disciplines (page 34). In other words, the courses which are most closely related to the actual practice of dentistry, as opposed to courses which represent the scientific and sub-structure of the discipline, tend to require visualization abilities. He concludes, "If one were interested in establishing a criterion for predicting successful completion of higher level dental courses, spatial reasoning would be the primary factor". (Page 123)

#### IN ASTRONOMY

In an investigation into the reasoning ability of college astronomy students, Schatz (1978) found that approximately 30% of the students were unable to use proportions correctly. He

suggested that such students were likely to experience difficulty with astronomical concepts which require the use of functional mathematical relationships, such as Kepler's Third Law and the Doppler effect. In addition, many individuals were expected to experience problems of a spatial/relational nature when plotting or interpreting graphs such as the Hertzsprung-Russell diagram of stellar evolution or the Hubble relationship. He also found that 37% of his college astronomy students could not determine the correct phases of the moons of Mars when observing a physical model removed from their own frame of reference. He questioned strongly whether individuals who experience this difficulty can understand the elaborate figures given in most textbooks to explain spatial concepts such as the phases of the moon, and the seasons.

Teaching eighth grade pupils in a suburban junior high school in Ohio, Bishop (1980) found that overall pupil performance on spatial tests in astronomy was unsatisfactory. The topics taught were the celestial sphere and earth rotation, the seasons, lunar phases and planetary positions and motions. Bishop found that the mean scores of the experimental groups on all six astronomy post-tests in these areas were less than the low figure of 25%, even though these pupils had been taught using a planetarium. The control group fared significantly worse! All pupils were pre- and post-tested for spa-

tial ability with the DAT Space Relations Test. Spatial ability was found to be significantly correlated with performance in the astronomy post-tests.

The superiority of the specially developed planetarium experimental teaching method was shown, but it was also established that most 13-14 year-old pupils were incapable of mastering projective astronomical concepts with any of the teaching methods adopted. However, spatial ability, gender and previous model manipulation experience were found to be important variables affecting performance.

Sonntag (1981) showed that the spatial orientation ability of university science students is a factor that should be considered when designing instructional techniques for classes learning positional astronomy. A completely crossed, two-factor experimental design was utilized to compare the effectiveness of three different teaching methods (planetarium lecture, classroom-celestial globe lecture, and planetarium/classroom-celestial globe lecture) and the effect of student spatial orientation ability (high, medium and low ability groups) on the learning of selected positional astronomy concepts. The results showed that students in the high spatial orientation ability group favoured the classroom teaching method, whereas the low and medium spatial orientation ability

groups performed better on the researcher-constructed Positional Astronomy Achievement Post-test if they were in the planetarium or planetarium/classroom-celestial globe groups.

Using clinical interviews, Kelsey (1980:2539-A) worked with 100 beginning college astronomy students to establish a scale for the tasks (listed from easiest to most difficult):

1. Mountains
2. Tilt of Cones and Rings
3. Mountains and Stars
4. Person-Centered Model Phases of Moon
5. Earth-Centred Model Phases of Moon
6. Top-of-drawing Phases of Moon.

Mental structures associated with tasks (1) and (3) were necessary but not sufficient for dealing with the others. Save for those scoring highest on the Mountains task, there was no significant relationship between grade in the astronomy course and the task subscores. Only 35% of the subjects successfully completed the Tilt of Cone and Rings test and 12% the Top-of-drawing. Those with 20 credits in mathematics and science scored no higher than other students. Kelsey calls for a review of materials requiring projective infralogical reasoning by students with such limited capabilities.

Another negative finding has been recorded by O'Brien (1980:6222-A). Using a population of 138 high school physics pupils, no evidence was found to support the hypothesis that spatial ability, as measured by NFER Spatial Test 3, influences ability or achievement in the study of optics (a component of most astronomy courses) as presented by the PSSC physics course.

It appears that the results of different spatial investigations in astronomy are not always in harmony, and that much may depend on the nature of the astronomical topic selected for study and the nature of the spatial tests chosen to measure spatial ability or achievement. However, there does appear to be some agreement that students with poor three-dimensional visualization may underachieve academically in astronomy.

#### IN ENGINEERING DRAWING

One of the earliest studies conducted with science students at college level was by Stuit & Lapp (1941). A high correlation between scores made on the Minnesota Paper Form Board Test of visualization, and success in both engineering drawing and mathematics was noted, but the correlation with success in physics was not significant.

Blade & Watson (1955) administered two tests of spatial orientation to a group of students entering college. The tests were then readministered after the freshman year. They found that among engineering students there were significant differences in spatial test results between the students with the highest grades and students with the lowest grades (after freshman year). They also found significant spatial test differences based upon a student's chosen engineering specialty. Mechanical engineers had the highest spatial results, followed by electrical, then civil and finally chemical. Comparing the pre- (upon entry) and post- (after freshman year) spatial test results they report that engineering students had a significantly greater gain than non-engineering students. This is tentatively attributed to a spatial training effect associated with studies in engineering.

In a study of 11-13 year-old pupils admitted to the Technical School in Middlesborough in 1950 and 1951, Smith (1960) found that NFER Spatial Test 1 scores correlated 0.62 with performance in an engineering drawing examination written three years later, and that Moray House Space Test 1 scores correlated 0.41 and 0.30 with performance in engineering drawing examinations taken five years later. It thus appeared that spatial ability is a skill which is largely innate.

Stallings (1968) hypothesized that instruction in descriptive geometry in a general engineering course would produce an increase in Spatial Relations Test scores. The resultant data did not firmly support the hypothesis, but the study could have been improved by the use of randomly selected control groups.

In another attempt to improve the ability to visualize spatial relations, Campbell (1969:2354-A) divided 188 high school mechanical drawing pupils into an experimental group and a control group. Both groups were taught by the lecture-demonstration method, but the experimental group also used a programme containing orthographic projection. It was found that the experimental training did not significantly increase pupils' ability to visualize spatial relations.

Marsicano (1975) evaluated tests which can be used for predicting academic success in engineering technology at Pennsylvania State University. He concluded that the traditional combination of high school results and verbal and mathematical scholastic aptitude tests can be improved by including spatial perception and abstract reasoning tests in the predictive battery.

In an article in the Times Higher Education Supplement, Birmingham (1976) described an investigation into cultural variation in spatial and mechanical reasoning undertaken with first year BSc (Hons) engineering students during a ten-year period at a College of Technology (now a Polytechnic). There appeared to be a marked difference in spatial ability - defined as the ability to visualize concrete objects, and to manipulate those visualizations - between students originating from Britain, and those originating from the countries of South East Asia. Although there was no evidence of correlation between spatial ability and general intellectual capacity, it was clear that weakness in the former was a severe handicap in studying engineering subjects. The article did not attempt to suggest whether the differences found between the cultural groups were the results of genetic factors, or the results of differing background experiences.

Whilst Birmingham's study has clear implications for follow-up investigations in Faculties of Engineering in South Africa, the present research is intentionally non-cultural in nature. It is particularly concerned with spatial ineptitude as a likely cause of academic failure in all types of students, irrespective of culture or background. Future culturally-based studies, however, could conceivably employ aptitude tests for spatial perception, such as those described by

Deregowski (1977) and Brohn & Cowan (1977), which have been administered to first year engineering students at the University of Rhodesia (now Zimbabwe) with strong predictive validity.

In an investigation into the results of a first course in engineering drawing at the University of the Witwatersrand, Taylor (1980) used step-wise multiple regression equations to establish that the best combination of predictors in his study consisted of three tests : the DRAT, the Blox and the H Test. The Deductive Reasoning Ability Test (DRAT) is a non-spatial test of logic and inference, but the Blox test is spatial and consists of items which require the respondent to study a particular configuration of cubes, and to identify the same configuration of cubes seen from a different view. In the H Test, which is also spatial, each question consists of a geometric figure which has to be imagined as an object that can be bent or rolled into a three-dimensional model.

Taylor also used the Gottschaldt Figures Test (GFT) which is a measure of flexibility of closure related to Witkin's "field independence" construct. Its predictive effectiveness was reduced by the fact that it correlated with the engineering drawing scores at widely varying levels.

Taylor's findings tend to confirm the appropriateness of the nature of the spatial tests designed for use in the present study with engineering drawing students at the University of Cape Town in 1983.

In Taylor's second report (1983) mention is made of the fact that a large percentage of end-of-year failures in engineering drawing and design obtained lower scores on the BLOX TEST when the time allowed was decreased. It should be noted, too, that intercorrelations between the five spatial engineering drawing and design examinations themselves throughout the year varied from only 0.35 to 0.63 (N=340). Also, the GFT emerged as an important predictor of examination success after the first term, but the multiple regressions indicate the difficulty in making individual predictions.

More recently, Kemp (1983) reports that a newly developed test for assessing competence in the contextualised technical language used by engineers is being used to assess students in their first year of university study.

To conclude this brief 40-year survey of the literature on spatial ability and success in engineering drawing, it appears that only Taylor (1983) has indicated that failing scores in a single sub-test out of a whole battery of sub-tests may be

used to identify students who are likely to experience outright failure in engineering drawing examinations. This observation will be pursued further during the present investigation.

Previous studies on the relationship between spatial visualization ability and academic success in chemistry, physics, biology and mathematics provide additional valuable insights, and are reviewed in Appendix G. Whilst clearly relevant, this subsidiary material does not bear directly on the current literature review.

#### CONCLUSIONS THAT CAN BE DRAWN ABOUT THE RELATIONSHIP BETWEEN SPATIAL VISUALIZATION ABILITY AND ACADEMIC SUCCESS

From this review of previous studies on the relationship between spatial ability and academic achievement in medicine, dentistry, astronomy, engineering, physical science, biology, mathematics and other disciplines, the following provisional conclusions may be drawn :

1. Traditional science-orientated subjects tend to attract students who, as a group, have above average spatial ability.

2. Improvements in spatial visualization scores tend to be associated with a formalized study of certain scientific disciplines over a period of months or years.
3. Spatial reasoning ability is reported to be the single, most important factor determining academic success in certain science subjects.
4. In some science courses, approximately one-third of individuals experience difficulty interpreting two-dimensional text-book representations of three-dimensional objects and their movements, and this problem may exacerbate academic performance to a marked degree.
5. High spatial visualizers, as a group, tend to achieve equally well academically, whether taught in a traditional, formal, didactic manner, or taught using concrete, three-dimensional, manipulable materials. Low spatial visualizers, as a group, however, tend to achieve better on spatially-orientated achievement post-tests when taught by concrete, hands-on methods (such as models in combination with two-dimensional materials, for instance).
6. The effect of the spatial factor on academic achievement varies from discipline to discipline, and even from topic to topic within a given scientific discipline. The measurable effects also vary, depending on the nature and

type of spatial test selected for predictive or diagnostic purposes.

7. In certain scientific subjects - but not in others - the measurement of an individual's spatial visualization ability enables academic achievement to be predicted accurately within clearly defined margins of error.
8. In many areas of science there is a moderate, but significant relationship between competence in spatial visualization and performance in university examinations.

#### ASSUMPTIONS AND UNANSWERED QUESTIONS ARISING FROM THE LITERATURE SURVEY

For the purposes of the present investigation, it is assumed that marked differences in visual perception do occur from individual to individual, and that these variations are associated with, and may even cause, significant underachievement in anatomy, astronomy and engineering drawing at university level. It is assumed that spatial visualization is one of the important components of visual perception which is significantly associated with performance in these scientific disciplines; and that three-dimensional cognition can be measured, in part, by different types of standardized tests of spatial ability which are intercorrelated, with a non-trivial subset of them possibly falling under a higher order factor.

Certain unanswered questions also arise from the literature survey. For example, many of the investigators employed batteries of objective-type sub-tests of geometric spatial ability which yielded global scores. The significance of the performances of testees who passed overall on a battery of spatial ability, but who failed outright in one or more of the component sub-tests, does not appear to have been explored.

The diagnostic and predictive powers of discipline-orientated spatial tests compared to merely geometric tests of spatial ability have not been investigated (except, perhaps, in the case of mechanical drawing). In addition, little work appears to have been done on the use of open-ended tests of spatial ability and on the interpretation and significance of individuals' resultant free responses, such as the drawing of distorted sketches.

Of particularly importance appears to be the dearth of investigations into the establishment of spatial ineptitude as a significant cause of outright academic failure in certain university disciplines. The development of predictive and diagnostic measures for the identification of such students during their courses of study, with a view towards possible early remediation, also calls for investigation.

Finally, whilst a number of studies have been carried out into the relationship between spatial visualization ability and academic success for whole classes in anatomy, astronomy and engineering drawing, no research appears to have monitored the separate spatial and non-spatial learning of university science students month by month, or term by term, through a single year.

C. STUDIES ON POSSIBLE CAUSES OF SPATIAL INEPTITUDE

A number of studies have suggested possible causes of inferior three-dimensional perception. Kilbride and Robbins (1968) found significant correlations between education level and ability to interpret pictorial depth perspective amongst the Baganda in Uganda, whilst Tomkins & Miner (1959) found that White labourers from an isolated and culturally restricted rural community in the USA did not perceive pictures (with depth cues) three-dimensionally, pointing to the importance of environmental stimulation. Bradley (1981) also found a relatively high positive correlation ( $r=0.61$ ) between the level of cognitive development of college biology students and spatial visualization ability.

Work done by Dawson (1967) suggests that personality may be associated with the comprehension of pictorial depth cues. He

found that Africans from tribes in which there was a high level of maternal strictness (and associated field-dependence) comprehended pictorial depth cues less often than individuals from tribes with a low level of maternal strictness (and associated field-independence). Dawson reported that he was able to teach individuals to interpret depth cues, but the field-independent individuals showed the most improvement. He suggested that the reason for this was that field-dependent subjects are more conforming and less open to new experiences, making them more resistant to learning new ideas.

Taylor (1983:16) found that a lack of art training was associated with consistently lower (but not significantly lower) results in engineering drawing at the University of the Witwatersrand. Rolfe (1980:14), on the other hand, lists language factors in addition to cultural factors as possible causative agents of spatial ineptitude amongst engineering students at the University of Rhodesia (now Zimbabwe).

Attempting to answer the question, "Why do American children lag in spatial conceptualization, since relatively sophisticated science programs are available in elementary schools?", Doyle (1980:58) suggests three possible reasons:

- (a) Current syllabuses offer a potpourri of spatially-oriented activities which are not based on a unified learning model such as Piaget's;
- (b) Activities provided are inappropriate for the pupil's level of intellectual development; and
- (c) Science is neglected by elementary teachers who do not consider it important.

Genetic factors may be responsible, in part, for wide variations which seem to occur in spatial visualization. In an investigation into the relationship between spatial ability and preferred handedness in college students, Burnett, et al. (1982) found that extreme handedness was associated with poorest spatial performance. Decreased hemispheric specialization was associated with increased spatial ability, and males outperformed females at all levels of handedness when measured as a continuous variable. Berry, et al. (1980), however, found that there was a significant advantage for right-handed undergraduates on spatial and sequential tasks, and a slight advantage for males. This was attributed to hemispheric interference experienced by left-handers.

Many other investigations, on the other hand, suggest that measured differences in spatial ability between males and females are the result of environmental rather than genetic

factors. After statistically controlling for the amount of coursework taken, or for the amount of previous experience, sex differences tend to disappear on tests of spatial ability (de Wolf, 1981; Williams, 1979; Smail, 1983).

D. INVESTIGATIONS UTILIZING SPECIAL TEACHING OR REMEDIATION METHODS FOR STUDENTS DEFICIENT IN THREE-DIMENSIONAL VISUAL PERCEPTION

In Appendix H a more detailed account is given of the findings of 25 recent investigations into the facilitation of spatial achievement by students in a variety of academic contexts. Whilst clearly relevant, these subsidiary studies do not have a direct bearing on the results of the investigation reported in this thesis. They may be summarized as follows :

1. Students with depth-perception problems can, in general, improve their spatial performances significantly when remediated by means of stereoscopic/planoscopic diagrams or colour/black outlining of diagrams or an audio/written exposition of diagram perception skills or models combined with cued diagrams of the models and shadow-projection machines.
2. A combination of slides of two- and three-dimensional tasks, rotations and three-dimensional image formation,

plus models and manipulatives may improve spatial visualization.

3. The use of line diagrams in both text and test situations tends to improve academic achievement by comparison with a purely verbal approach.
4. The use of the Karplus learning cycle in combination with pupil model manipulation and pupil drawing tends to raise the level of academic achievement in spatially-orientated topics.
5. Students who are emotionally mature and accept the fact that they are spatially disabled tend to improve more than emotionally immature students.
6. The use of trained remedial art specialists is recommended with neurologically-impaired, spatially defective pupils.
7. Pupils who construct models of objects under study over a long period of time (say, six months), or who engage in woodwork, metalwork and technical drawing, tend to achieve better in spatially-orientated subjects and on geometric tests of spatial visualization.

8. The use of visual games, origami, jig-saw puzzles, etc., may facilitate spatial development.
9. The use of stereoscopic drawings tends to increase spatial achievement, but not necessarily in the case of students with severe depth-perception problems.
10. The use of shadow diagrams sometimes produces a significant increase in spatial learning, but sometimes does not.
11. Rotations about an axis are best taught using films with a fine degree of explicitness. Lap-dissolve slides, coupled with  $10^\circ$  shifts in perspective and an optimum exposure time, tend to maximize spatial gains.

#### CONCLUSIONS AND IMPLICATIONS THAT CAN BE DRAWN

A review of findings on the effectiveness of different teaching methods with students deficient in three-dimensional visual perception leads to the following conclusions. Different types of visual problems are often associated with different academic subjects and topics, and the nature and severity of spatial disabilities varies with the age, background, culture, experience and language of individuals. Remedial techniques which are effective in one subject area with one group of students, are not necessarily effective with

other students in different learning situations. The results obtained in previous investigations may guide the teacher or lecturer in the design of remedial instruction, but there is scope for innovation. Evaluation of the effectiveness of experimental, differentiated teaching methods must always be an integral part of spatial instructional processes.

### CHAPTER THREE

#### EXPERIMENTAL DESIGN, SAMPLE, CRITERION AND PREDICTORS

In this chapter the setting for the investigation is presented, and the characteristics of the nine populations chosen for study are described, together with reasons for their selection. The research methods employed in the investigation are identified and the design, development, refinement and properties of the geometric spatial battery are described. The format of the statistical analysis is also explained.

The experimental designs specific to each of the disciplines anatomy, astronomy and engineering are delineated in terms of hypotheses, the selection of criterion scores, the selection of predictors, the characteristics of the measures, the rationale and procedures for execution of the programmes, and the collection of data. Finally, the refinement and characteristics of the measures are described for each of the three disciplines.

#### THE SETTING FOR THE INVESTIGATION

The entire study was conducted in four faculties (Medicine, Science, Engineering and Education) in the University of Cape Town, an English-speaking multi-racial institution of some 11 000 students, of whom approximately 85% are of local European background.

## THE POPULATIONS SELECTED

The nine experimental samples involved a total of 1126 undergraduate students, of whom 621 were selected for more intensive spatial investigation. Four of the samples were second year medical students, three were second year astronomy students, one was a first year class of student engineers, and one was a population of specialized clinical remedial education students. The sizes of the samples varied from N=275 in the case of novice engineering students to N=8 in the case of failed anatomy students who returned to repeat a year. The great majority of students were tested between 1980 and 1983, although certain students were participants in preliminary interviews prior to 1980, and minor items of missing data were gathered early in 1984.

The nature and characteristics of the nine populations, together with the rationale for their selection, are set out below.

POPULATION I consisted of 38 novice anatomy students who were failing by mid-year (June) in 1980. These were interviewed and tested on a battery of spatial exercises in small groups during August 1980.

POPULATION II consisted of 154 novice students of anatomy who were mass-tested using a battery of geometric spatial exercises in February 1981 - that is, at the commencement of their course.

It should be noted that 13 students failed their year of anatomy outright in 1980, and returned to repeat the year in 1981. These were not included in POPULATION II, but are identified separately as POPULATION II(R).

POPULATION III(R) consisted of 8 students who failed their year of anatomy outright in 1982, and returned to repeat their year in 1983. They were tested with two different batteries of geometric spatial tests for the first time in August 1983 - that is after 18 months of lectures, tutorials and practical work in anatomy.

POPULATION IV consisted of 19 novice anatomy students who were failing by mid-year (June) in 1983. They were tested for geometric spatial ability using two different batteries of tests in August 1983.

POPULATION V consisted of 27 science and engineering students attending a popular introductory second-year-level course in descriptive astronomy. They were interviewed either individually or in pairs during the years 1979 to 1981. A variety of these students' spatial misconceptions in elementary astronomy were probed and recorded for the purpose of developing and refining a diagnostic astronomical spatial test appropriate for university science students.

POPULATION VI consisted of 55 novice students registered for the second year course in descriptive astronomy. These were mass-tested at the commencement of their year, using both a battery of geometric spatial exercises and a simplified version of the author's newly-developed astronomical spatial test called the Novice Astronomical Spatial Test. \*

POPULATION VII consisted of 25 novice students in the 1983 descriptive astronomy course who had intact test and examination results. They were given the author's Full Astronomical Spatial Test in November, at the conclusion of their course, followed by the geometric spatial battery which was administered individually.

POPULATION VIII consisted of 275 first year engineering drawing students who were mass-tested, using the geometric spatial battery, in March 1983, that is, at the commencement of their course.

POPULATION IX consisted of 15 adult education students studying clinical remedial teaching. These were mass-tested in mid-1983, using two different batteries of geometric spatial tests, as part of the procedure for establishing the construct validity of these tests.

---

\*

FOOTNOTE

Items in this difficult Novice Test were rehearsed in interviews conducted with POPULATION V students, and required careful spatial reasoning based on a knowledge of the content of the core geography syllabus previously taught at the form 3 (grade 9) level to all (or most) school pupils in South Africa. The reasonable assumption was made that students had already learned in high school about the causes of sunrise and sunset; the phases of the moon and planets; the seasons; the rotation and revolution of the earth and planets in coplanar orbits around the sun; and the use of the Southern Cross to indicate the direction of the South Pole.

### SELECTION OF RESEARCH METHODS

In the initial stages of the investigation, clinical interviews were conducted with anatomy and astronomy students so that emerging spatial misconceptions could be questioned, probed and clarified where possible. Tape-recorded transcripts were made of students' reasoning about instances of spatial visualization. In addition, the Illuminative Evaluation approach of Parlett & Hamilton (1972) was employed when discussing the problem with both lecturers and students. Useful, unexpected and interesting insights were gleaned as a result.

For the major part of this investigation, the ex post facto research method has been employed. Cohen & Manion (1980:148) state that this method is particularly suitable in educational contexts where the independent variable or variables lie outside the researcher's control - for example, when investigating relationships between academic achievement and independent variables such as race, sex, intelligence or, in this case, spatial ability.

### THE DESIGN, DEVELOPMENT, REFINEMENT AND PROPERTIES OF THE AUTHOR-CONSTRUCTED GEOMETRIC SPATIAL BATTERY

Appendix I gives a detailed account of the considerations which led to the adoption of an author-designed battery in preference to commercially available tests of spatial ability. The factors which determined the nature and composition of the geometric spatial

battery are explained, and details of the sub-tests adopted are set out. An account is also given of the refinement of the pilot sub-tests during interviews with 43 anatomy students, and with a panel of nine lecturers in anatomy. The question of the imposition of time limits is also investigated. Details concerning the statistical properties of the battery (means, ranges, reliability coefficients, inter-correlations between sub-tests, and so on), are also set out for the different groups in Appendix I.

At this point, it is sufficient to record that the refined author-constructed geometric spatial battery consisted of four sub-tests, as follows :

- RV Rotation, visualization and juxtaposition of geometric objects in three dimensions.
- RC Rotation of cubes in space.
- SYN Synthesis of sections of common geometric objects.
- SEC Sectioning of geometric solids.

A copy of this refined battery is included in Appendix I, pages I8 to I18.

Science undergraduates' scores on this refined battery ranged from 0 to the maximum of 33, with a mean mark of 25.6 = 77.6% and a SD

of 5.08 = 15.4% (N=537). The Cronbach alpha coefficient for the geometric battery was  $\alpha = 0.82$ . Individuals who were at least one standard deviation below average - that is, who scored less than 63% on this battery, were classified as likely remedial subjects. (This cut-off point is in harmony with the criterion score of 23 out of 36 utilized by Nicholson & Seddon, 1977.) Also, individuals who failed outright on any of the four sub-tests were identified as possible remedial students, in harmony with the criterion recently adopted by Taylor (1983:27).

Finally, the construct validity of the investigator-constructed geometric spatial battery was established using POPULATIONS III(R), IV and IX, by correlating students' scores with the scores they obtained in NFER Spatial Test 3. The result obtained was  $r = 0.84$  (N=42). Calculation of the Cronbach alpha reliability coefficient for NFER Spatial Test 3 yielded  $\alpha = 0.97$  (N=42).

---

FOOTNOTE. NFER, who supplied Spatial Test 3, are not responsible for any of the conclusions reached in this thesis. Copyright precludes the inclusion of NFER 3 questions in Appendix I.

### FORMAT OF THE STATISTICAL ANALYSIS

Normal probability plots for the computed standardized residuals of the measures used in this investigation showed that the data satisfied the criteria of normality and homoscedasticity. (See, for example, Table 3.1.) Thus, the statistical tests, which depend on these properties, could be carried out.

#### Selection of dependent and independent variables

For the four populations of anatomy students, the practical examination scores of April, June and October/November were chosen as dependent variables. The independent variables were :

TABLE 3.1      Normal probability plot for the standardized residuals of the data for POPULATION II

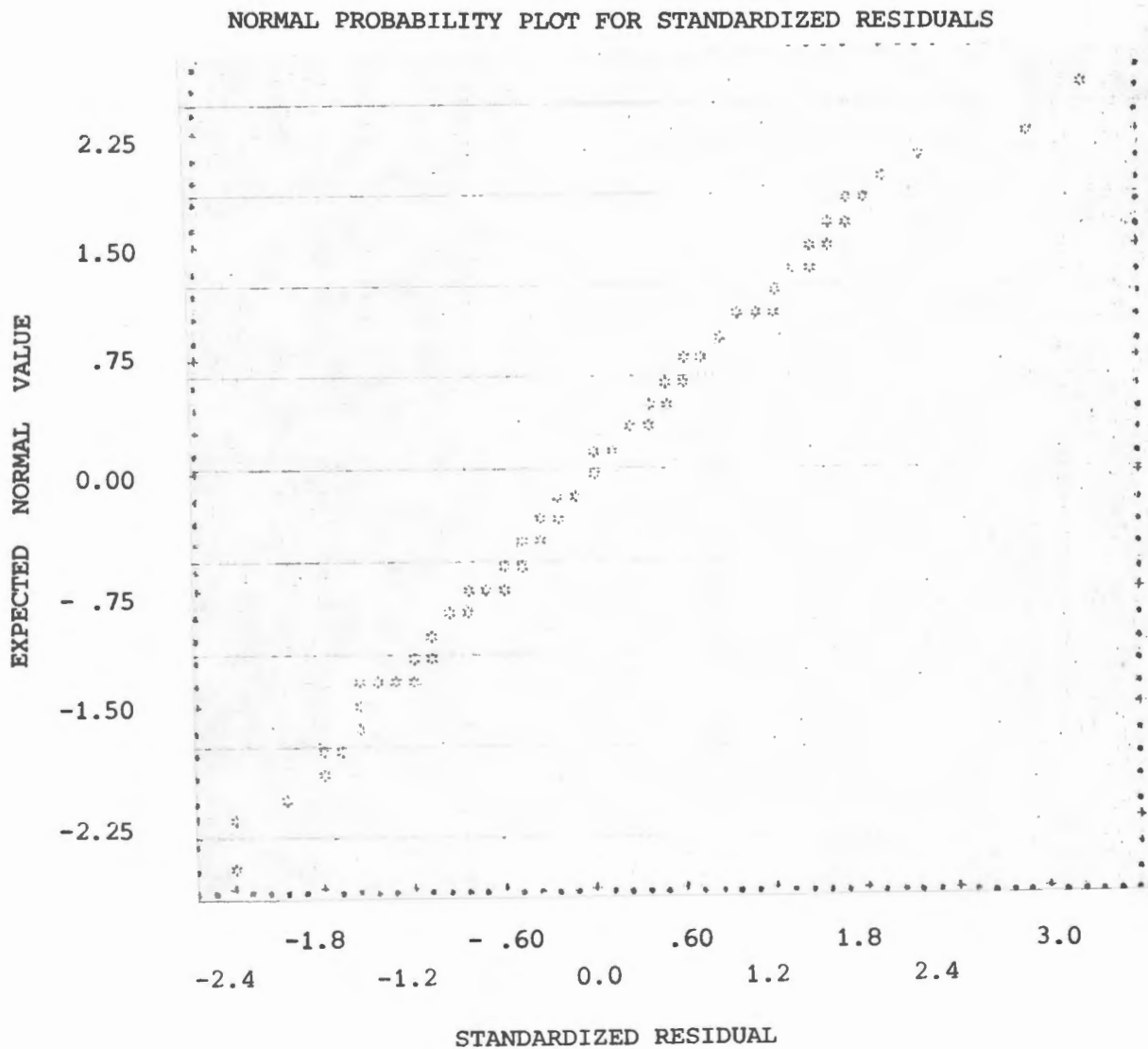

- (i) the geometric spatial battery scores;
- (ii) the spatial MCQ scores in the April, June and November theory examinations;
- (iii) the non-spatial MCQ scores in the April, June and November theory examinations;
- (iv) the essay examination scores of April, June and November; and
- (v) for POPULATIONS I, III(R) AND IV, the August test scores of the Fredman Synthesis of Anatomical Sections Test.

In the case of the astronomy students :

For POPULATION VI, the dependent variable was the first semester examination score in descriptive astronomy. The independent variables were :

- (i) the March geometric spatial battery scores; and
- (ii) the scores obtained in March on the Novice Astronomical Spatial Test.

For POPULATION VII, the dependent variables were the scores on three class tests (May, July and September), and on the final November examination in descriptive astronomy. The independent variables were :

- (i) the geometric spatial battery scores obtained in November; and
- (ii) the scores obtained on the Full Astronomical Spatial Test administered in November - that is, at the end of the course.

In the case of the engineering students (POPULATION VIII), the dependent variables were the June (mid-year) and November (end-of-year) examination results in engineering drawing . The independent variables were :

- (i) the Matriculation aggregate symbol (usually obtained during the previous November);
- (ii) the Matriculation mathematics symbol (usually obtained during the previous November); and
- (iii) the geometric spatial battery scores obtained in March.

The geometric spatial battery was not given to the volunteer astronomy students who comprised POPULATION V.

Copies of the instruments used to measure the dependent and independent variables with the various populations of anatomy, astronomy and engineering students appear in Appendix J.

### Selection of statistical tests

The significance of the under-achievement of spatially weak students in comparison with spatially able students was determined using t-tests for independent samples.

Regression analyses were employed to establish whether spatial ability, as measured by the various spatial tests used in the investigation, accounts for a significant percentage of the variance in the students' academic achievement scores.

Correlational analyses were used to detect significant relationships (which may or may not be causal) between the different variables. Fisher's Z-transformation was employed to examine the significance of differences amongst the individual correlations themselves.

Occasional chi-squared tests and Fisher's exact probability tests were used to test for significant differences between the frequencies of various critical incidents.

### Refinement of the measures

Error and discrimination analyses were performed on anatomical and astronomical measures of achievement set in MCQ format. Item inversions and ambiguities were detected and eliminated using the procedure recommended by Koeslag, et al. (1979).

Items in the Novice Astronomical Spatial Test and the Full Astronomical Spatial Test were checked for their spatial nature, and for ambiguities, by two lecturers in astronomy who worked independently.

The anatomical MCQs were judgementally classified as either "spatial MCQs" or as "non-spatial MCQs" by three different lecturers in anatomy who worked independently. Spatial MCQs required students to visualize in three dimensions; non-spatial MCQs did not. The three lecturers fully agreed on 85% of the 525 MCQs classified, so the remaining 15% of doubtful items were eliminated from the subsequent statistical analysis.

#### EXPERIMENTAL DESIGN SPECIFIC TO ANATOMY

##### Hypotheses

1. That under-achievement in practical anatomy is significantly related to performance scores on paper-and-pencil tests of geometric spatial ability.
2. That when mid-year failures in anatomy are split into two groups on the basis of performance on subject-independent diagnostic paper-and-pencil tests of geometric spatial ability, the spatially competent sub-group will score significantly higher marks than the spatially weak sub-group in those as-

pects of anatomy which require the ability to visualize accurately in three-dimensions.

3. That spatial ability will be acquired by a majority of spatially weak students during the normal course of their year of anatomy, but that a minority of spatially weak students will remain visually handicapped.
4. That the predictive validity of paper-and-pencil tests of spatial ability will decrease significantly with increasing time, as spatially inept students who commence their year of anatomy become more spatially competent (according to spatial MCQ and practical examination scores) during their course of studies.
5. That significant under-achievement in anatomy will be recorded for groups of students who
  - (a) fail outright (in total marks) on diagnostic batteries of geometric spatial exercises; and/or
  - (b) fail outright in one or more sub-tests which comprise a battery of geometric spatial exercises; and/or
  - (c) draw more than one grossly disproportionate\* sketching error in a battery of diagnostic spatial exercises; and/or

- (d) draw more than five mild\* sketching errors in the battery of diagnostic spatial exercises.
6. That spatial ineptitude occurs only amongst anatomy students who fail anatomy or who gain a third class pass in the subject.
  7. That an anatomical spatial MCQ test will be a significantly better predictor of achievement in anatomy practical examinations than the geometric spatial battery.
  8. That the geometric spatial battery will be a significantly better predictor of achievement in anatomy practical examinations than a non-spatial anatomical MCQ test.

---

FOOTNOTE \*Criteria for the classification of students' sketching errors as either "grossly disproportionate" or "mild" are set out in Appendix K.

**TABLE 3.2** The practical anatomical measures, geometric spatial measures, anatomical spatial measures and non-spatial anatomical measures taken with anatomy students at the University of Cape Town in 1980 and 1981.

NATURE OF THE STUDENT POPULATION		POPULATION I (1980)	POPULATION II (1981)
		MID-YEAR FAILURES	NEW INTAKE
POPULATION SIZE		38	154
DEPENDENT VARIABLES	PRACTICAL ANATOMY EXAMINATION MARKS	APRIL PRAC. (%) JUNE PRAC. (%) OCT. PRAC. (%)	APRIL PRAC (%) JUNE PRAC. (%) OCT. PRAC. (%) NOV. PRAC. (%)
INDEPENDENT VARIABLES	GEOMETRIC SPATIAL MEASURES	AUGUST BATTERY OF SPATIAL EXERCISES: <u>RV</u> (10) <u>RC</u> (5) <u>SYN</u> (6) <u>SEC</u> (5) TOTAL: (26)	FEB. BATTERY OF SPATIAL EXERCISES: <u>RV</u> (10) <u>RC</u> (5) <u>SYN</u> (5) <u>SEC</u> (12) <u>IM</u> (5) TOTAL: (37)
	ANATOMICAL SPATIAL MEASURES	APRIL SPATIAL MCQ's (22) JUNE SPATIAL MCQ's (48) AUGUST <u>FRED</u> (6) NOV. SPATIAL MCQ's (113)	JUNE SPATIAL MCQ's (35) NOV. SPATIAL MCQ's (92)
VARIABLES	NON-SPATIAL ANATOMICAL MEASURES	APRIL ESSAY (%) JUNE ESSAY (%) NOV. ESSAY (%) APRIL NON-SPATIAL MCQ's (32) JUNE NON-SPATIAL MCQ's (28) NOV. NON-SPATIAL MCQ's (60)	JUNE ESSAY (%) NOV. ESSAY (%)  JUNE NON-SPATIAL MCQ's (22) NOV. NON-SPATIAL MCQ's (48)
	COMPOSITE MEASURE	FINAL YEAR MARK	FINAL YEAR MARK

Selection of the criterion scores  
and the predictors in anatomy

Table 3.2 summarizes the practical anatomy measures (the criterion scores), the geometric spatial measures, the anatomical spatial measures and the non-spatial anatomical measures (the predictors) performed on POPULATIONS I and II. For POPULATIONS III(R) and IV the geometric spatial measures included NFER Spatial Test 3, and a qualitative test of sketching ability, and were administered in August 1983, otherwise the pattern of testing and examining remained similar to that in 1980 and 1981.

For the purposes of the anatomy investigation, it was easier to use refined MCQ scores uncorrected for guessing. This decision is supported by Cross, et al. (1980) who state that reliability and validity indices offer little to recommend different types of choice-weighted scoring over number-right scoring in tertiary courses.

Programme rationale, execution  
and data collection for anatomy

During the years 1980 to 1983, the normal programme of teaching and examining occurred in anatomy, except for intervention by the geometric spatial battery on one occasion for each of the POPULATIONS I to IV. In an endeavour to find the optimum time for intervention by the geometric battery (that is, at 0 months, after 6 months, or

after 18 months for remedial purposes), the following schedule was executed :

- POPULATION I, 1980 Intervention occurred after 6 months with the mid-year failures only (N=38)
- POPULATION II, 1981 Intervention occurred at the beginning of the course with the intake of novice anatomy students (N=154)
- POPULATION III(R), 1983 Intervention occurred for the first time after 18 months with the students who failed the previous year, and who were repeating (N=8)
- POPULATION IV, 1983 Intervention occurred after 6 months with the mid-year failures only (N=19), to confirm the 1980 findings, but using two different geometric spatial batteries (that is, NFER 3 as well as the author-constructed battery).

#### EXPERIMENTAL DESIGN SPECIFIC TO ASTRONOMY

##### Hypotheses

9. That under-achievement in class tests and examinations in descriptive astronomy is significantly related to performance scores on paper-and-pencil tests of spatial ability for students who

- (a) fail outright (in total score) on a diagnostic battery of geometric spatial exercises; and/or
  - (b) fail outright on a predictive Novice Astronomical Spatial Test; and/or
  - (c) fail outright on a diagnostic Full Astronomical Spatial Test; and/or
  - (d) draw more than one grossly disproportionate sketch on the Full Astronomical Spatial Test; and/or
  - (e) fail outright in one or more sub-tests comprising the battery of geometric spatial exercises; and/or
  - (f) draw more than one grossly disproportionate sketching error in the geometric spatial battery.
10. That spatial ineptitude occurs only amongst astronomy students whose performance on university class tests and examinations is consistently below average.
11. That the Novice Astronomical Spatial Test, administered in March, will be a significantly better predictor of achievement in descriptive astronomy than the geometric spatial battery.
12. That the Full Astronomical Spatial Test, administered in November, will be a better diagnostic measure of spatial inepti-

tude in astronomy than the geometric spatial battery, also administered in November.

Selection of the criterion scores  
and the predictors in astronomy

These have been described in the previous section, under the sub-heading Selection of dependent and independent variables. Copies of the various instruments appear in Appendix J.

Programme rationale, execution and  
data collection for astronomy

POPULATION V, consisting of science students registered for the second-year level course in descriptive astronomy during the years 1979-1981, was used to develop, modify and refine both the Novice Astronomical Spatial Test and the Full November Astronomical Spatial Test. The formulation of these tests occurred using clinical interview techniques.

For each of the POPULATIONS VI and VII, the normal programme of teaching and examining occurred in descriptive astronomy; except for an intervention at one point during each of the two years by the spatial testing programme. POPULATION VI attempted both the geometric spatial battery and the Novice Astronomical Spatial Test together in March - that is, at the commencement of the academic year.

POPULATION VII attempted both the geometric spatial battery and the Full Astronomical Spatial Test in November - that is, at the completion of the course.

The prime purpose of this sequential arrangement was to compare the predictive validities of the geometric and astronomical spatial tests with their diagnostic validities.

Students in both POPULATION VI and POPULATION VII were also asked to make sketches of simple, everyday objects. No marks were assigned for this task, but note was taken if grossly disproportionate sketches occurred.

#### EXPERIMENTAL DESIGN SPECIFIC TO ENGINEERING DRAWING

##### Hypotheses

13. That under-achievement in the first semester examination and in the final examination in engineering drawing is significantly related to performance scores on paper-and-pencil tests of geometric spatial ability. In particular, significant under-achievement in engineering drawing will be recorded for groups of students who
  - (a) fail outright (in total marks) a predictive battery of geometric spatial exercises administered at the commencement of the course; and/or

- (b) fail outright in one or more sub-tests which comprise the battery of geometric spatial exercises; and/or
- (c) draw more than one grossly disproportionate sketching error in the battery.

14. That the geometric spatial battery scores contribute significantly more to the variance in the University examination marks in engineering drawing than either the Matriculation mathematics symbols or the Matriculation aggregate symbols.

Selection of the criterion scores and the predictors for engineering drawing

These have been described earlier under the sub-heading Selection of dependent and independent variables. Copies of the instruments appear in Appendix J.

Programme rationale, execution and data collection for engineering drawing

POPULATION VIII consisted of 275 engineering drawing students. For normal teaching purposes, these were divided into two approximately equal groups which attended a three-hour laboratory session once per week. In March 1983 these groups attempted the geometric spatial sub-tests RV and RC during one laboratory session, and sub-tests SYN and SEC during the following week's practical session. Time limits of 15 minutes were imposed in both cases, but only to

ensure that minimal interference occurred with the normal schedule of laboratory practical work.

Students of engineering drawing were included in the present investigation for several reasons. Firstly, the investigation sought to establish whether the presence of gross sketching errors in students' drawings (which characterize the spatial ineptitude of many anatomy students) would also occur amongst students in other scientific disciplines - that is, can this finding be generalized?

Secondly, it was pre-supposed that the geometric spatial battery is, in itself, almost a pure test of "engineering drawing spatial ability". Hence, it was expected to yield higher predictive correlations with university examination results in engineering drawing than with results in anatomy or in descriptive anatomy, in accordance with the hypothesis that a discipline-orientated test of spatial ability is the most powerful single diagnostic or predictive measure available to university teachers.

Thirdly, it was desired to establish whether a geometric spatial test administered at the commencement of a course in engineering drawing could identify students who were likely to fail on the mid-year and end-of-year university examinations in this subject. If so, the feasibility of implementing appropriate remedial programmes could be investigated.

### SUMMARY OF CHAPTER

In this chapter, the characteristics of nine populations of university students have been described, together with reasons for their selection. The research methods employed in the study have been outlined, and the format of the statistical analysis has been explained.

The design, development, refinement and properties of various spatial measures have been described. The spatial measures employed in the investigation as independent variables are :

- (i) a refined geometric spatial battery consisting of four sub-tests: RV, RC, SYN and SEC
- (ii) NFER Spatial Test 3 (geometric)
- (iii) anatomical spatial MCQ scores
- (iv) the FREDMAN Synthesis of Anatomical Sections Test
- (v) the Novice Astronomical Spatial Test
- (vi) the Full Astronomical Spatial Test, and, possibly
- (vii) the Matriculation mathematics symbols.

The non-spatial measures employed in the investigation as independent variables are :

- (i) anatomical non-spatial MCQ scores
- (ii) essay examination scores in anatomy, and

(iii) the Matriculation aggregate symbol.

The dependent variables are :

- (i) practical examination scores in anatomy
- (ii) class test and examination scores in descriptive astronomy, and
- (iii) mid-year and end-of-year examination results in engineering drawing.

Anatomy and astronomy students in 1983 and 1984 were also asked to make quick, accurate sketches of everyday objects such as a spade, a matchbox and a bus. Note was taken of this exercise only if grossly disproportionate sketches were drawn.

Fourteen different hypotheses have been formulated, and the rationale and procedures for collection of the data and execution of the programmes have been explained for the three disciplines anatomy, astronomy and engineering.

## CHAPTER FOUR

### PRESENTATION AND ANALYSIS OF DATA

In this chapter, a considerable volume of detailed data are presented and analyzed. The application of the various measures previously discussed is presented separately for the three disciplines of anatomy, astronomy and engineering. Summaries are presented on pages 126, 128, 130, 132 to 134, 150, 151, 156, 158 to 160, 177 and 179.

#### A. RESULTS : ANATOMY

Particular note should be taken of the fact that a major thrust in this thesis research has been focussed on the investigation of spatial ability in students of anatomy. Since this is a virtually untouched area of research, the relevant analysis is presented in some detail. In the light of the supporting literature on this important subject, the major findings of this thesis research are, at the time of writing, in the process of being published in a paper in the British Journal, Medical Education, entitled "Spatial Learning Disabilities and Under-Achievement Amongst University Anatomy Students" (Rochford, 1985).

## 1. THE DIAGNOSTIC AND PREDICTIVE VALIDITIES OF THE MEASURES

Although the term "predictive validity" is commonly used in studies of spatial ability, the term "diagnostic validity" is not. Some research workers, such as Messick (1980), advocate the term "diagnostic utility", in which case this expression should replace the term "diagnostic validity" which is used throughout this thesis.

### POPULATION I

POPULATION I consisted of 38 anatomy students out of 170 who were failing by mid-year (June) in 1980. It was suspected that poor three-dimensional appreciation may contribute significantly to this failure rate.

#### (a) The diagnostic and predictive validities of the geometric spatial battery with POPULATION I

The mean score of this group on the geometric spatial battery, administered in August, was 63%. This is significantly ( $p < 0.01$ ) lower than the mean score of 78% which the whole of POPULATION II (N=154) obtained in February 1981. Since it has been well established (for example, Martin, 1968; Bermingham, 1976; O'Brien, 1980) that broad academic achievement and intelligence are generally independent of spatial ability, there appears to be a strong case for analyzing these results in detail.

Tables 4.1 and 4.2 record the results of the t-tests used to investigate the differences in performance on practical and other examinations of 14 failing anatomy students who scored particularly well on the battery of spatial exercises, compared with the 16 failing anatomy students who performed particularly badly on the battery in August 1980. (Students classified as geometrically spatially able score 19 - 24 on the battery of spatial tests; those grouped as geometrically spatially inept score 6 - 14 out of 26 marks on the battery.)

The diagnostic value of the battery of spatial exercises would appear to be high. As expected, both groups score equally well on the non-spatial examinations in anatomy : the April, June and November essay examinations and the non-spatial MCQ areas of the June and November objective-type examinations. The geometrically spatially handicapped group, however, drops more than 17% - that is, on average, more than 17 marks out of 100 - in both the April and June practical examinations (Table 4.1), which is statistically significant ( $p < 0.01$ ), and drops 8% to 10% on spatial MCQs (Table 4.2), relative to the geometrically spatially able group, which is also statistically significant ( $p < 0.05$ ). The difference between the spatially competent and the spatially inept group on the

TABLE 4.1

t-test results for the differences in performance on practical examinations, essays and the Fredman Test of the 1980 (POPULATION I) anatomy students who were failing by mid-year but who were spatial opposites in August, according to the battery of geometric spatial exercises

(A = ABLE : Battery scores 19-24 ; H = HANDICAPPED : Battery scores 6-14)

	PRACTICAL MARKS (%)				ESSAY EXAMINATION MARKS (%)				(MAX 6) FREDMAN TEST						
	JUNE		OCTOBER		APRIL		JUNE			NOVEMBER					
	A	H	A	H	A	H	A	H		A	H				
N	14	15	13	16	14	14	14	14	13	16	14	14	13	3.6	2.1
MEANS	63.3	45.5	55.8	38.3	57.5	49.2	42.2	41.6	39.0	40.6	48.2	50.3			
MEAN DIFFERENCE	-17.8%		-17.5%		-8.3%		-0.6%		+1.6%		+2.1%			-1.5	= -25%
S.D.	12.7	10.5	12.7	12.6	13.3	10.6	6.1	6.0	6.2	7.2	17.8	11.9	1.2	1.0	
S.E.M.	3.4	2.7	3.5	3.2	3.5	2.8	1.6	1.6	1.7	1.8	4.8	3.1	0.32	0.29	
t(SEP)	4.09		3.70		1.82		0.16		-0.32		-0.72		3.61		
t(POOLED)	4.12		3.70		1.82		0.16		-0.31		-0.72		3.59		
p(SEP)	0.004		0.001		0.08		0.88		0.75		0.48		0.001		
p(POOLED)	0.003		0.001		0.08		0.88		0.76		0.48		0.001		
SIGNIFICANCE	p < 0.01**		p < 0.01**		N.S.		N.S.		N.S.		N.S.		N.S.		p < 0.01**
LEVENE F FOR VARIANCES	0.47		0.43		1.11		0.38		0.03		1.82		1.39		
P	0.50		0.52		0.30		0.54		0.83		0.19		0.25		

TABLE 4.2 t-test results for the differences in performance on spatial and non-spatial MCQ's of the 1980 (POPULATION I) anatomy students who were failing by mid-year but who were spatial opposites according to the battery of geometric spatial exercises given during interviews in August, 1980.

(A = ABLE : Battery scores 19-24; H = HANDICAPPED : Battery scores 6 - 14).

	APRIL MCQ		JUNE MCQ		NOVEMBER MCQ	
	SPATIAL	NON-SPATIAL	SPATIAL	NON-SPATIAL	SPATIAL	NON-SPATIAL
N	14	15	13	16	14	14
MEANS (%)	41.1	50.6	47.6	45.9	51.4	52.1
MEAN DIFFERENCE	-9.6%	-7.5%	-8.2%	-0.6%	-4.5%	-0.3%
t (POOLED)	2.24	1.55	1.99		1.07	-0.02
P (POOLED)	0.03	0.13	0.05		0.29	0.99
SIGNIFICANCE	p < 0.05 <sup>a</sup>	N.S	p = 0.05 <sup>*</sup>	N.S	N.S	N.S.

Fredman Synthesis of Anatomical Sections Test is clear-cut (an average 25% drop) and highly significant ( $p < 0.001$ ) too.

The correlations of 0.55 and 0.53 between the battery scores and the April and June practical examination marks (Table 4.3) are also statistically significant ( $p < 0.01$ ), as are the correlations between the battery scores and the April and June spatial MCQ scores, indicating the diagnostic value of the geometric battery.

The efficiency of the August battery of geometric spatial tests in predicting the October results is also evident (although less strong), doubtless because of the more motivated learning which occurs during the second semester when students realize the possibility of outright failure if their practical marks do not improve. In the October practical examination the geometrically spatially inept students obtain an average of 8% less than the high scorers on the geometric battery ( $p = 0.08$ ) (Table 4.1), and the correlation between battery scores and October practical marks is also statistically significant ( $p < 0.05$ ) (Table 4.3).

TABLE 4.3 Corpair correlation matrix for the scores of the 38 interviewed anatomy students in 1980 (POPULATION I)

	JUNE SPATIAL MCQ	JUNE NON-SPATIAL MCQ	(APRIL + JUNE) SPATIAL MCQ	(APRIL + JUNE) NON-SPATIAL MCQ	NOVEMBER SPATIAL MCQ	(A.+J.) NON-SPATIAL MCQ	(APR. + JUNE) SPATIAL MCQ	JUNE NON-SPATIAL MCQ	NOVEMBER NON-SPATIAL MCQ	APRIL PRAC.	JUNE PRAC.	OCTOBER PRAC.	RV	RC	SYN	FRED	SEC	BATTERY TOTAL
JUNE SPATIAL MCQ	1,00																	
JUNE NON-SPATIAL MCQ	0,70	1,00																
(APRIL + JUNE) SPATIAL MCQ	0,95	0,66	1,00															
(APRIL + JUNE) NON-SPATIAL MCQ	0,76	0,84	0,81	1,00														
NOVEMBER SPATIAL MCQ	0,80	0,55	0,84	0,77	1,00													
NOVEMBER NON-SPATIAL MCQ	0,61	0,45	0,61	0,63	0,79	1,00												
APRIL PRAC.	0,58	0,24	0,62	0,46	0,52	0,47	1,00											
JUNE PRAC.	0,65	0,42	0,68	0,55	0,66	0,47	0,79	1,00										
OCT. PRAC.	0,63	0,41	0,67	0,62	0,77	0,62	0,67	0,67	1,00									
RV	0,30	0,03	0,31	0,11	0,12	0,16	0,39	0,31	0,21	1,00								
RC	0,17	-0,01	0,25	0,20	0,16	-0,02	0,31	0,43	0,38	0,42	1,00							
SYN	0,13	0,01	0,15	0,07	0,04	-0,09	0,45	0,36	0,13	0,29	0,42	1,00						
FRED	0,44	0,27	0,47	0,35	0,28	0,28	0,40	0,47	0,20	0,35	0,23	0,39	1,00					
SEC	0,09	-0,17	0,01	-0,09	0,18	0,18	0,39	0,44	0,21	0,30	0,26	0,51	0,21	1,00				
BATTERY TOTAL	0,32	-0,01	0,39	0,13	0,14	0,08	0,55	0,53	0,31	0,86	0,72	0,75	0,63	0,36	1,00			
INTERVIEW IMPRESSION MARK	0,16	-0,08	0,19	0,04	0,02	-0,04	0,47	0,36	0,13	0,64	0,48	0,76	0,54	0,60	0,87	1,00		

Levels of statistical significance

$r \geq 0.25$   $p < 0.05$

$r \geq 0.36$   $p < 0.01$

When the performances of students failing in practical examinations and on spatial MCQs in anatomy are analyzed one by one from April through to November, the value of the battery as a practical diagnostic and predictive instrument can be assessed for individual students. (See, for example, Table 1.2, p15; Table 4.16, p138).

It was found that the geometric battery scores agree with and confirm the anatomical spatial performances of 31 of the 38 failing students; that the results could be interpreted either way in the case of 5 students, due to insufficient data, or debatable scores occurring; and in the remaining 2 cases the validity of the geometric battery as an indicator of individual anatomical spatial performance was refuted - that is, contradictory scores appeared.

Thus the diagnoses made by the geometric spatial battery were in agreement with students' anatomical spatial performances in 82% of cases, were not clear-cut in 13% of cases, and were disputed or contradicted in 5% of cases with POPULATION I.

The predictive validity of the battery was also confirmed in this way with POPULATION I. Twelve of the 16 students

failing the battery in August 1980 did not overcome their anatomical spatial handicaps by November.

(b) The diagnostic and predictive validities of the anatomical spatial MCQ scores of POPULATION I.

Amongst the 38 students who were failing anatomy by mid-year in 1980, were 15 students whose spatial MCQ anatomy examination scores were always at least 7% below their non-spatial MCQ anatomy examination scores from April through to November; that is, their MCQ spatial handicaps were persistent and large enough to be statistically significant. On the other hand, 10 failing students scored better on spatial MCQs than on non-spatial MCQs in both the June and November anatomy examinations, apparently demonstrating their attainment of spatial competence.

t-tests were carried out on the scores obtained by these two groups in practical examinations, in essay examinations, on spatial and non-spatial MCQs and on the battery of spatial exercises. The results are summarized in Table 4.4.

It is clearly evident that persistent significant spatial MCQ deficits are associated with significantly lower battery scores (of the order of 25%) and with persistently lower practical examination scores (of the order of 12% to 17%), whilst performances on non-spatial

TABLE 4.4

t-test results for the differences in performance on practical examinations, essays, non-spatial MCQ's and the battery of spatial exercises of 25 of the 1980 POPULATION I anatomy students who were failing by mid-year, and who recorded persistent MCQ spatial deficits in every MCQ examination which averaged at least 7% for the whole year.

(A=SPATIALLY ABLE ON MCQ'S ; H = PERSISTENTLY HANDICAPPED ON SPATIAL MCQ'S)

	PRACTICAL MARKS (%)						SPATIAL MCQ MARKS (%)						NON-SPATIAL MCQ'S (%)						AUGUST BATTERY (%)		ESSAY MARKS (%)			
	APRIL		JUNE		OCTOBER		APRIL		JUNE		NOVEMBER		APRIL		JUNE		NOVEMBER		APRIL		JUNE		NOVEMBER	
	A	H	A	H	A	H	A	H	A	H	A	H	A	H	A	H	A	H	A	H	A	H	A	H
N	10	14	9	15	10	13	10	14	9	15	10	13	10	14	9	15	10	13	10	15	9	15	10	13
MEANS (%)	57.9	43.9	51.7	34.9	54.4	42.9	38.1	29.4	47.9	37.1	52.0	40.2	52.5	51.1	38.4	44.7	49.3	50.9	19.8	13.3	39.1	39.9	47.7	46.2
MEAN DIFFERENCE	-14.0%		-16.8%		-12.5%		-8.7%		-10.8%		-11.8%		-1.4%		+6.3%		+1.6%		-6.5%	-25%	+0.8%		-1.5%	
S.D.	13.8	7.6	14.0	11.2	13.9	7.8	15.5	11.1	10.2	8.7	11.5	7.9							4.7	4.4				
S.E.M.	4.4	2.0	4.7	2.9	4.4	2.2	4.9	3.0	3.4	2.2	3.6	2.2							1.5	1.1				
t (SEP)	2.92		3.07		2.54		1.52		2.64		2.77								3.48					
t (POOLED)	3.21		3.25		2.73		1.60		2.76		2.91								3.53					
P (SEP)	0.01		0.008		0.02		0.15		0.02		0.01								0.003					
P (POOLED)	0.004		0.004		0.01		0.12		0.01		0.008								0.002					
SIGNIFI-	p < 0.01**		p < 0.01**		p < 0.05**		N.S.		p = 0.01**		p = 0.01**		N.S.		N.S.		N.S.		p < 0.01**		N.S.		N.S.	

essay examinations and on non-spatial MCQs remain the same for the two groups.

Hence, the ability to succeed on MCQs which require spatial visualization, and in practical anatomy, appears to be strongly related to the ability to cope with the battery of spatial tests for POPULATION I.

The ability of the April and June spatial MCQ scores to predict the November practical marks is also evident ( $r = 0.67$ ,  $p < 0.01$  in Table 4.3).

- (c) The diagnostic validity of the individual sub-tests within the battery of geometric spatial exercises for POPULATION I.

It was hypothesized that, irrespective of total battery score, outright failure on any one of the four geometric sub-tests in the battery will be associated with anatomical spatial problems during the year - either in practical work, or in spatial MCQ performance, or in both.

The hypothesis is confirmed for POPULATION I. For the 1980 group it is found that none of the 12 students who are anatomically spatially competent (judging by their practical and spatial MCQ examination results) fails a

single battery sub-test, whilst every one of the 25 students who fail one or more geometric sub-tests simultaneously record spatial problems, particularly in the practical anatomy examinations.

(d) The diagnostic and predictive validity of sketching errors

During the interviews conducted in mid-1980, it was also noted that every student who drew at least one grossly misaligned sketch of a simple three-dimensional object was also found to be manifesting significant anatomical spatial disabilities in practical anatomy examinations and in anatomical spatial MCQs. Seventeen of the 43 students interviewed (that is, 39%) drew seriously spatially defective diagrams of this nature, examples of which are reproduced in Appendix K.

POPULATION II

154 novice anatomy students in 1981

The pattern of testing conducted during 1980 was repeated in 1981 but the amended battery of spatial exercises was given to 154 second year medical students at the beginning of their course in anatomy, in order to establish its long-term predictive value with more certainty. The diagnostic and predictive validities of the spatial MCQs were also reviewed.

(a) The diagnostic and predictive  
validities of the geometric  
spatial battery with POPULATION II

The predictive validity of the battery of geometric spatial exercises was confirmed. Regression equations were computed for different subsets of the 1981 measures, and the subsets that were most efficiently predicted were established. The analysis with POPULATION II revealed that the students' battery scores obtained at the commencement of their year of anatomy made a very significant ( $p < 0.01$ ) contribution to the prediction of both their April and June practical examinations scores.

The regression equations obtained were :

$$\begin{aligned} \text{APRIL PRAC MARK} &= - 5.527 + 0.403 \text{ BATTERY SCORE} \\ &\quad - 0.278 \text{ NOVEMBER ESSAY SCORE} \\ &\quad + 1.395 \text{ FINAL ANATOMY MARK} \end{aligned}$$

$$\begin{aligned} \text{JUNE PRAC MARK} &= - 29.837 + 0.491 \text{ BATTERY SCORE} \\ &\quad - 0.167 \text{ NOVEMBER ESSAY SCORE} \\ &\quad + 1.670 \text{ FINAL ANATOMY MARK} \end{aligned}$$

These equations establish the significant, important and lasting effect of spatial ability on achievement in practical anatomy.

Students who failed the battery in February 1981 recorded drops of 10% and 14% in the April and June practical examinations in anatomy ( $p < 0.01$ ) and 6% in the November practical examinations ( $p=0.05$ ), compared to students who scored well on the battery (Table 4.5). Both groups of students scored equally well on the non-spatial anatomical MCQ and essay examinations.

17 out of 18 students who scored less than 55% on the geometric spatial battery in February subsequently recorded serious anatomical spatial problems during the year, particularly in practical examinations.

A total of 37 of the 154 novices scored less than the pass mark of 63% on the geometric spatial battery. 28 of these 37 cases subsequently manifested marked spatial anatomical problems in practical examinations and/or on MCQs; 3 predictions were borderline confirmations; 2 predictions could be neither confirmed nor disproved with

**TABLE 4.5** t-test results for the differences in performance on subsequent practical examinations, essays, spatial MCQ's and non-spatial MCQ's of the 1981 (POPULATION II) anatomy students who were spatial opposites in February according to the battery of spatial exercises.

( A = ABLE : Battery scores 33 - 37 ; H = HANDICAPPED : Battery scores 0 - 22 )

	PRACTICAL ANATOMY MARKS (%)												ESSAY MARKS (%)			JUNE MCQ MARKS (%)			NOVEMBER MCQ MARKS (%)		
	APRIL		JUNE		OCTOBER		NOVEMBER		JUNE		NOVEMBER		SPATIAL <sup>35</sup>		NON-SPATIAL <sup>22</sup>		SPATIAL <sup>72</sup>		NON-SPATIAL <sup>48</sup>		
	A	H	A	H	A	H	A	H	A	H	A	H	A	H	A	H	A	H	A	H	
N	38	25	38	26	38	26	37	26	36	26	37	26	38	26	38	26	38	26	38	26	
MEANS (%)	57.4	47.3	65.5	51.8	62.9	57.1	67.8	61.5	56.8	52.4	56.3	53.8	51.8	47.2	57.3	53.7	55.5	52.7	59.2	58.7	
MEAN DIFFERENCE	-10.1%		-13.7%		-5.8%		-6.3%		-4.4%		-2.5%		-4.6%		-3.6%		-2.8%		-0.5%		
S.D.	13.1	13.7	14.0	16.4	12.5	14.1	9.6	15.0	4.1	6.2			11.7	13.7							
S.E.M.	2.1	2.7	2.3	3.2	2.0	2.8	1.6	2.9	0.7	1.2			1.9	2.7							
t (SEP)	2.90		3.48		1.70		1.89		1.58				1.42								
t (POOLED)	2.93		3.59		1.74		2.03		1.68				1.46								
P (SEP)	0.006		0.001		0.10		0.07		0.12				0.16								
P (POOLED)	0.005		0.001		0.09		0.05		0.10				0.15								
SIGNIFICANCE	p 0.01**		p 0.01**		N.S.		N.S.		N.S.				N.S.						N.S.		

certainty due to insufficient data (since students were absent from subsequent examinations); and 4 predictions proved to be incorrect.

Thus, the predictions made by the geometric battery with POPULATION II were in harmony with students' subsequent anatomical performances in 84% of cases, were not clear cut in 5% of instances, and were contradicted in 11% of cases. These figures are consistent with those obtained for POPULATION I. (See page 101.)

In the case of POPULATION II, however, it should be noted that 13 of the identified 37 novice students who failed the geometric spatial battery in February, nevertheless subsequently scored relatively high marks on every examination in anatomy during 1981 and were never in danger of failing. Far from refuting the predictive validity of the battery, the majority of these students proceeded to score significantly lower on spatial MCQs compared to non-spatial MCQs. Under normal circumstances, it is doubtful whether their spatial weakness in anatomy would ever have been detected.

This finding is important because it demonstrates that poor three-dimensional appreciation amongst anatomy stu-

dents occurs at almost all levels of achievement and, in part, probably accounts for relatively low correlation coefficients which are normally obtained between measures of spatial ability and academic achievement.

Finally, 23 students who failed both the February battery and subsequent practical examinations in anatomy, dropped an average of more than 10% on spatial MCQs relative to non-spatial MCQs in anatomy ( $p < 0.01$ ).

(b) The diagnostic and predictive validities of the anatomical spatial MCQ scores of POPULATION II

The diagnostic validity of the spatial anatomical MCQs would appear to be high. Compared with students who were always spatially able, according to their MCQ spatial performances in June and November, students who recorded persistent, average drops of at least 8% on spatial MCQs relative to non-spatial MCQs in anatomy, also recorded drops of 10% on the June practical examination in anatomy ( $p=0.01$ ). Students with MCQ spatial deficits averaging at least 18% over the whole year dropped 13%, 15% and 11% respectively in the April, June and October practical examinations in anatomy ( $p < 0.05$ ). These spatially opposite groups scored equally well on the essay examinations in anatomy, but the spatially handicapped group

consistently scored 8% to 11% better on the non-spatial MCQs ( $p < 0.01$ ). The complete analysis is set out in Table 4.6.

The predictive validity of the June spatial MCQ scores was also confirmed. They correlated 0.59 with the October practical examination marks ( $p < 0.01$ ) and 0.76 with the final year marks ( $p < 0.01$ ) for the 37 students who failed the battery of spatial exercises in February 1981. By contrast, the June non-spatial MCQ scores correlated only 0.46 and 0.59 respectively (Table 4.7).

(c) The predictive validity of the battery's sub-tests was confirmed

22 of the 25 students who failed badly in one or more geometric sub-tests in February subsequently manifested serious spatial problems in anatomy, particularly in practical work.

(d) The predictive validity of sketching errors

40 of the 47 students who drew one or more grossly distorted freehand diagrams of simple, common objects on battery exercises SYN and SEC in February, subsequently manifested significant evidence of anatomical spatial disability, especially in practical examinations.

**TABLE 4.6 t-test results for the differences in performance on practical examinations, essays and non-spatial MCQ's of the 25 1981 anatomy students from POPULATION II who always score higher on spatial MCQ's (CONTROL GROUP) and the 1981 anatomy students who record persistent MCQ spatial deficits in both June and November which average at least 8%(GROUP IIA), 9%(GROUP IIB), 16%(GROUP IIC) and 18%(GROUP IID) over the year.**

	PRACTICAL EXAMINATION MARKS (%)				ESSAY EXAMINATION MARKS (%)			NON-SPATIAL MCQ'S (%)				GROUPS
	APRIL	JUNE	OCTOBER		JUNE	NOVEMBER		JUNE (22)	NOVEMBER (48)	JUNE/NOV. (70)		
N (CONTROL)	25	25	25		25	25		25	25	25		CONTROL GROUP
MEANS (%)	56.9	69.4	66.0		61.6	58.4		53.1	58.2	56.5		Spatial MCQ marks always higher than non-spatial MCQ marks.
N (IIA)	55	54	54		52	52		53	53	51		GROUP IIA Persistent spatial MCQ deficits of at least 8%
MEANS (%)	53.1	59.9	61.1		56.8	58.5		64.3	66.2	65.9		
MINUS MEAN A	-3.8%	-9.5%	-4.9%		-4.8%	+0.1%		+11.2%	+8.0%	+9.4%		
t	1.06	2.5	1.34									
P	0.29	0.01	0.18									
SIGNIFI-	N.S.	p=0.01**	N.S.		N.S.	N.S.						
N (IIB)	49	48	49		46	46		47	47	45		GROUP IIB Persistent MCQ spatial deficits of at least 9%
MEANS (%)	51.8	58.2	59.2		55.6	57.6		63.9	65.6	65.4		
MINUS MEAN B	-5.1%	-11.2%	-6.8%		-6.0%	-0.8%		+10.8%	+7.4%	+8.9%		
t	1.32	2.89	1.85									
P	0.19	0.005	0.07									
SIGNIFI-	N.S.	P 0.01**	N.S.		N.S.	N.S.						
N (IIC)	16	16	16		16	16		16	16	16		GROUP IIC Persistent MCQ spatial deficits of at least 16%
MEANS (%)	49.1	56.9	57.9		56.8	56.2		63.1	66.4	65.6		
MINUS MEAN C	-7.8%	-12.5%	-8.1%		-4.9%	-2.2%		+10.0%	+8.2%	+9.1%		
t	1.62	2.32	1.68									
P	0.11	0.01	0.10									
SIGNIFI-	N.S.	P 0.05*	N.S.		N.S.	N.S.						
N (IID)	8	8	8		8	8		8	8	8		GROUP IID Persistent MCQ spatial deficits average from 18% to 24%
MEANS (%)	43.6	54.9	55.3		56.5	57.3		63.8	66.3	65.6		
MINUS MEAN D	-13.3%	-14.5%	-10.7%		-5.1%	-1.2%		+10.8%	+8.1%	+9.0%		
t	2.47	2.31	2.06									
P	0.02	0.03	0.05									
SIGNIFI-	P 0.05*	P 0.05*	p=0.05*		N.S.	N.S.						



Also, 27 of the 34 students who made five or more mild sketching errors and omissions in battery sub-tests SYN (Synthesis of Sections of Solid Objects) and SEC (Sectioning of Solid Objects), subsequently failed in one or more practical examinations ( $\chi^2 = 22.9$ ,  $p < 0.001$ , Table 4.8). This data is analyzed in greater detail in Appendix L.

These results offer considerable support for the suggestion that students' sketches of simple three-dimensional objects can be used for both diagnostic purposes (as in 1980) and for predictive purposes (as in 1981).

#### POPULATION III(R)

This group of 8 out of 165 students failed anatomy outright in 1982, and returned to repeat the year in 1983. They were then tested with both the geometric spatial battery and NFER Spatial Test 3 for the first time in August 1983 - that is, 18 months after they had commenced the course. Their scores are recorded in Table 4.9 and, on this basis, the eight students were classified as four geometrically spatially handicapped and four geometrically spatially able.

TABLE 4.8 The relationship between the number of different sketching errors and omissions in two spatial exercises completed by 139 novice second-year anatomy students (POPULATION II) in February 1981 and their subsequent performances in practical examinations in April, June and November.

		NUMBER OF STUDENTS WHO SUBSEQUENTLY FAILED IN ONE OR MORE PRACTICAL EXAMINATIONS	NUMBER OF STUDENTS WHO SUBSEQUENTLY PASSED ALL PRACTICAL EXAMINATIONS
NUMBER OF DIFFERENT SKETCHING ERRORS AND OMISSIONS ON THE COMBINED FEBRUARY TASKS <u>SYN</u> AND <u>SEC</u>	0 - 4	36	62
	5 - 20	34	7

$$\chi^2 = 22,9 ; \text{d.f.} = 1 ; p < 0.001$$

Table 4.9 Results of the geometric spatial testing of POPULATION III (R) in August 1983

STUDENT NO.	NFER SPATIAL TEST 3		AUTHOR-CONSTRUCTED GEOMETRIC SPATIAL BATTERY (PASS MARK 63%)		DOES THE STUDENT APPEAR TO HAVE A GEOMETRIC SPATIAL PROBLEM ?
	%	NO. OF SUB-TESTS FAILED	%	NO. OF SUB-TESTS FAILED	
8201 R	72	1	54	3	YES
8202 R	76	1	38	4	YES
8203 R	58	3	27	5	YES
8204 R	69	3	50	3	YES
8205 R	85	1	69	0	NO
8206 R	96	0	87	0	NO
8207 R	92	0	77	0	NO
8208 R	98	0	89	0	NO

(a) The diagnostic validities of the geometric spatial batteries with POPULATION III(R)

Although the number of students involved in the analysis is too small for the results to be generalized, a comparison is made of the performances of the geometrically spatially able and the geometrically spatially handicapped anatomy students in Table 4.10.

At first glance, it appears that both groups' performances in the repeated year are approximately equal, implying that practical anatomical spatial ability may be learned, given sufficient time. A vertical comparison of the non-spatial MCQ performances of the two groups, however, indicates that the spatially handicapped students are superior by an average of 20% in April and 15.7% in June. This implies that the geometric spatial battery has again been successful in diagnosing significant deficits in MCQ spatial performance in anatomy.

Additional support for this conclusion may be derived from a comparison of the average marks of the two groups in 1982, that is, in the previous year of anatomy which

TABLE 4.10

A comparison of the performances on the April and June 1983 examinations of the geometrically spatially able and the geometrically spatially handicapped anatomy students constituting POPULATION III (R).

		APRIL EXAMINATION: MEAN SCORES					JUNE EXAMINATION: MEAN SCORES				
PRAC.	SPATIAL	MCQ			ESSAY	PRAC	SPATIAL	MCQ		NET DIFFERENCE	ESSAY
		NON SPATIAL	NET DIFFERENCE	NON SPATIAL				NET DIFFERENCE			
GEOMETRICALLY SPATIALLY ABLE (N = 4)	71.8%	61.3%	51.8%	+9.5%	54.0%	69.3%	48.7%	55.3%	-6.4%	36.0%	
GEOMETRICALLY SPATIALLY HANDICAPPED (N = 4)	70.3%	61.5%	71.8%	-10.3%	49.5%	73.0%	65.2%	71.0%	-5.8%	42.0%	

they failed. It was found that the geometrically spatially handicapped group (N=4) was 7% to 8% superior on the non-spatial essay examinations than the geometrically spatially able group (N=4), although there was no significant difference between their mean practical examination scores in April, June and October 1982. Because of the small samples, however, these data are, at best, only suggestive.

(b) The diagnostic validity of the anatomical spatial MCQ scores for POPULATION III(R)

Each of the four students in POPULATION III(R) who passed the geometric spatial battery scored equally well (or equally badly) on both spatial and non-spatial MCQs. Three of the four students who failed the battery, on the other hand, still recorded large MCQ spatial deficits in March 1983 (for example, -26%), but by June 1983 most of the MCQ spatial drops were not significant.

(c) The diagnostic validity of individual sub-tests within the battery of geometric spatial exercises for POPULATION III(R)

The results set out in Table 4.9 support the diagnostic technique of noting students who fail sub-tests on a standardized battery of tests of spatial visualization ability.

(d) The diagnostic validity of gross sketching errors for POPULATION III(R)

The observations recorded in Table 4.9 are wholly consistent with those made in 1980 and in 1981.

POPULATION IV

In 1983, 19 novice anatomy students out of 166 were failing by mid-year (June). These constituted POPULATION IV, and were mass-tested by means of the geometric spatial battery and NFER Spatial Test 3 in August - that is, six months after the commencement of their course. Their scores are recorded in Table 4.11 and, on the basis of these results, 10 students were classified as geometrically spatially handicapped, and 9 as spatially competent.

(a) The diagnostic and predictive validities of the geometric spatial batteries with POPULATION IV

Table 4.12 records the results of the t-tests used to investigate the differences in performance on practical and other university examinations between the two groups.

STUDENT NO.	N F E R 3		AUTHOR-CONSTRUCTED GEOMETRIC SPATIAL BATTERY (PASS MARK 63%)			DOES THE STUDENT APPEAR TO HAVE A GEOMETRIC SPATIAL PROBLEM ?
	%	NO. OF SUB-TESTS FAILED	%	NO. OF SUB-TESTS FAILED	GROSS SKETCHING ERRORS ?	
8301	76	2	30	4	YES	YES
8302	90	1	49	3	YES	YES
8303	56	3	47	1	YES	YES
8304	59	3	45	5	YES	YES
8305	87	0	54	2	YES	YES
8306	77	0	56	3	NO	YES
8307	94	0	54	3	YES	YES
8308	79	1	52	1	NO	YES
8309	59	4	48	2	YES	YES
8310	89	0	72	1	YES	YES ?
	MEAN = 76.6%		MEAN = 50.7%			
8311	94	0	74	0	NO	NO
8312	95	0	80	0	YES	NO ?
8313	98	0	80	0	NO	NO
8314	92	0	78	0	NO	NO
8315	100	0	77	0	NO	NO
8316	100	0	79	0	NO	NO
8317	94	0	89	0	NO	NO
8318	85	0	87	0	NO	NO
8319	94	0	87	0	NO	NO
	MEAN = 94.7%		MEAN = 81.2%			

TABLE 4.12 Differences between geometrically spatially able and geometrically spatially weak novice anatomy students who were mid-year failures in 1983 (POPULATION IV) with regard to mean performance on essay, MCQ and practical examinations.

	MEAN ESSAY EXAMINATION MARKS		MEAN MCQ EXAMINATION MARKS				MEAN PRACTICAL EXAMINATION MARKS				MEAN FINAL YEAR MARK FOR ANATOMY	
	(NON-SPATIAL)		NON - SPATIAL				( SPATIAL )					
	APRIL	JUNE	APRIL	JUNE	APRIL	JUNE	APRIL	JUNE	APRIL	JUNE		NOVEMBER
GEOMETRICALLY SPATIALLY ABLE STUDENTS (N = 9).	39,8%	21,1%	26,1%	32,2%	39,1%	36,3%	27,7%	39,0%	43,6%	52,7%	54,5%	45,4%
GEOMETRICALLY SPATIALLY WEAK STUDENTS (N=10)	35,6%	17,8%	22,7%	25,3%	32,1%	27,1%	17,4%	25,4%	29,8%	41,0%	43,4%	37,6%
MEAN DROP IN ANATOMY EXAMINATION PERFORMANCE BY SPATIALLY WEAK STUDENTS	-4,2%	-3,3%	-3,4%	-6,9%	-7,0%	* -9,2%	* -10,3%	** -13,6%	* -13,8%	* -11,7%	-11,1%	- 7,8%
						t=1.97	t=1.89	t= 3.24	t= 1.86	t= 1.85	t = 1.38	t = 1.24
	NON-SPATIAL MEASURES				SPATIAL MEASURES							

\* Significant drop p < 0,08  
 \*\* Significant drop p < 0,01

NOTE: October Practical Marks omitted due to absences by spatially weak students.

Once again, the diagnostic value of the geometric spatial battery is confirmed. The geometrically spatially weak failing students significantly under-perform by 11.1% to 13.8%, on average, in the April, June and November practical examinations, compared to the spatially able failing students. They also under-score by a significant 13.6% on all anatomical spatial MCQs set between February and June 1983 (that is, on two examinations and two practice tests combined), although they also found the non-spatial MCQs more difficult than the spatially able group in this particular year- which does tend to counteract partially the statistical significance of the 13.6% spatial MCQ deficit obtained with POPULATION IV. Table 4.13 demonstrates that, statistically, the spatially competent failing students had a much better chance of improving their performance and passing during the second semester than did the spatially handicapped failing group, who were more likely to continue to fail their year outright.

(b) The diagnostic validity of the sub-tests with POPULATION IV

The results laid out in Table 4.11 confirm the value of noting students' failures in the individual sub-tests of the geometric spatial battery. This single, simple tech-

TABLE 4.13 A comparison of the ultimate fates of the geometrically spatially able and the geometrically spatially weak novice anatomy students who were mid-year failures in 1983 (POPULATION IV).

	PASSED THE YEAR AS A WHOLE BY NOVEMBER 1983	FAILED THE YEAR AS A WHOLE: CLASSIFIED AS "FAIL : REPEAT" OR "FAIL : SUPPLEMENTARY"	ABSENT OR WITHDRAWN.
GEOMETRICALLY SPATIALLY ABLE ( N = 9 )	6	2	1
GEOMETRICALLY SPATIALLY WEAK ( N = 10 )	2	7	1

Using Fisher's Exact Probability Test, the difference between the ultimate fates of the spatially able mid-year failures and the spatially weak mid-year failures is significant ( $p = 0,04$ ).

nique diagnosed all ten spatially handicapped students, and incorrectly classified none of the nine spatially able students.

The sub-tests of NFER 3 were partially successful, too, correctly identifying six of the ten spatially handicapped students. There appears to be a case for amending the Manual which accompanies NFER Spatial Test 3. Failures in any one sub-test appear to be just as important as pass or fail in total score. Anatomy students who scored 90% on NFER Spatial Test 3, but who unexpectedly failed just one of its sub-tests, were found to record significant spatial MCQ deficits of up to 28% in anatomy examinations.

(c) The diagnostic validity of gross sketching errors with POPULATION IV

The findings recorded in Table 4.11 demonstrate that this exercise successfully diagnosed eight of the ten spatially handicapped students, and incorrectly classified only one of the nine spatially able students.

SUMMARY FOR THE DIAGNOSTIC AND PREDICTIVE  
MEASURES USED WITH POPULATIONS I TO IV

To consolidate this section, the use of critical levels of performance such as low total battery scores, very low battery sub-task scores, persistently large MCQ spatial anatomical deficits, and the number and quality of errors in sketches made by students are particularly good diagnostic and predictive indicators of serious anatomical spatial weaknesses.

When used in combination with each other, their diagnostic utility and predictive validity is exceptionally high. Essay scores and other non-spatial marks in anatomy such as non-spatial MCQ scores have neither predictive nor diagnostic validity with regard to the manifestation of serious anatomical spatial handicaps amongst medical students. Clearly these findings must have implications for the teaching and the nature of the assessment of anatomy students.

## 2. THE DISCRIMINATION VALIDITIES OF THE MEASURES

Rothman & Kerenyi (1980) report that for second year medical students at the University of Toronto, correlation coefficients between practical examination scores and multiple-choice marks in the first and second term examinations in pathology were 0.46 and 0.55, respectively (N=250). The corresponding correlations obtained for the whole 1981 class of anatomy students at the University of Cape Town (POPULATION II) are comparable (N=154). When the spatial and non-spatial components of these anatomy examinations are separated from each other, however, the measures become much more discriminating and significantly higher correlation coefficients are obtained amongst groups of spatially handicapped students.

Table 4.3 records correlations between sets of spatial and non-spatial scores for students in POPULATION I, the majority of whom have low spatial ability. The correlations between spatial MCQ marks and practical examination scores for a given month are higher, and are as great as 0.77, whereas the correlations between the non-spatial MCQ marks and practical scores for a given month are depressed, and are as low as 0.24.

Thus, the spatial MCQ mark is a more discriminating predictor than the corresponding non-spatial MCQ mark of subsequent practical scores and of other marks which contain elements of spatial thinking,(such as the final year mark) in virtually every instance. In addition, many differences between pairs of spatial and non-spatial predictive correlation coefficients are statistically significant, e.g:

POPULATION I : (Table 4.3)

June spatial MCQ / November spatial MCQ	r=0.80	} p=0.003
June non-spatial MCQ / November non-spatial MCQ	r=0.45	

April prac / June spatial MCQ	r=0.58	} p=0.03
April prac / June non-spatial MCQ	r=0.24	

POPULATION II battery failures : (Table 4.7)

June spatial MCQ / June prac	r=0.68	} p=0.02
June non-spatial MCQ / June prac	r=0.32	

POPULATION II practical failures :

June spatial MCQ / June prac	r=0.51	} p=0.01
June non-spatial MCQ / June prac	r=0.12	

Significant differences between pairs of correlation coefficients were established using Fisher's Z-transformation.

For POPULATION I (Table 4.3), the ability of the August battery of spatial exercises to discriminate between the spatial and non-spatial anatomical MCQ scores of June 1980 is also statistically significant ( $p=0.02$ ).

### 3. THE INDEPENDENCE OF THE MEASURES

An indication of the independence or the inter-dependence of the measures may be gained from Table 4.3. The data presented strongly suggest that pairs of variables recording correlation coefficients which are consistently significantly different from zero are inter-dependent - that is, are causally related. It is also evident, however, that performance on the battery of geometric spatial exercises is completely independent of performance on non-spatial MCQs, as expected. This is also confirmed with POPULATION II (Table 4.7). It is also noteworthy that performance on non-spatial MCQs in anatomy is strongly related to spatial performance in anatomy, undoubtedly due to their common medical content.

A summary of the declining predictive correlation coefficients of different spatial tests and examinations in anatomy is recorded in Table 4.14.

#### 4. REPEATING STUDENTS

Thirteen students who failed their year of anatomy outright in 1980, returned to repeat the year in 1981. These were designated as POPULATION II(R). Eleven of these 13 students failed in 1980 manifesting large, persistent spatial deficits in anatomical spatial MCQs, as well as failing in practical examinations. They also performed badly on the battery of geometric spatial exercises.

By the end of their second year, however, only 6 of the 11 spatially inept students were still failing in one or more ~~more~~ practical examinations, and only 4 of these were still recording large spatial deficits in MCQs in anatomy.

It appears that the majority of spatially handicapped failed students do benefit spatially from repeating their year, but that several do not, despite two years of intensive teaching and examining.

**TABLE 4.14** Declining predictive correlation coefficients of different spatial tests and examinations in anatomy.

	SPATIAL MCQ		PRACTICAL EXAMINATIONS	
	JUNE	NOVEMBER	JUNE	OCTOBER/ NOVEMBER
APRIL PRAC. (1980, N=43)	0.58**	0.42**	0.79**	0.67**
APRIL PRAC. (1981, N=154)	0.45**	0.44**	0.69**	0.58**
APRIL PRAC. (1981, N=38)	0.52**	0.57**	0.72**	0.65**
AUGUST BATTERY (1980, N=43)	0.32**	0.14	0.53**	0.31*
FEBRUARY BATTERY (1981, N=154)	-	-	0.19**	0.04
JUNE PRAC. (1980, N=43)	0.65**	0.66**	-	(0.67)
JUNE PRAC. (1981, N=154)	0.62**	0.58**	-	(0.69)
JUNE PRAC. (1981, N=38)	0.68**	0.60**	-	(0.70)
(APRIL & JUNE) SPATIAL MCQ (1980, N=43)	-	(0.84)	0.68**	0.67**
JUNE SPATIAL MCQ (1980, N=43)	-	(0.80)	0.65**	0.63**
JUNE SPATIAL MCQ (1981, N=154)	-	(0.61)	0.62**	0.52**
JUNE SPATIAL MCQ (1981, N=38)	-	(0.69)	0.68**	0.59**

N = 43 refers to POPULATION I plus 5 volunteer anatomy students.

N = 154 refers to POPULATION II.

N = 38 refers to the battery failures of POPULATION II.

\* Significantly different from zero ( $p < 0.05$ )

\*\* Significantly different from zero ( $p < 0.01$ )

This pattern was repeated with the spatially inept students who failed anatomy outright in 1982, and who repeated the year in 1983. The repeating anatomy students performed better on a battery of geometric spatial tests than novice anatomy students who failed their first half year, suggesting that spatial ability may be acquired through over-learning and repetition.

#### 5. CONFIRMATION OF HYPOTHESES

The first four sub-sections of this report on the results obtained with POPULATIONS I to IV may be summarized by saying that all of the following hypotheses (except No. 6) are confirmed :

Hypothesis No. 1 - "That under-achievement in practical anatomy is significantly related to performance scores on paper-and-pencil tests of geometric spatial ability" is confirmed with POPULATIONS I, II, III(R) and IV.

Hypothesis No. 2 - "That when mid-year failures in anatomy are split into two groups on the basis of performance on subject-independent diagnostic paper-and-pencil tests of geometric spatial ability, the spatially competent sub-group will score significantly higher marks than the spatially weak sub-group in those aspects of anatomy which require the ability to visu-

alize accurately in three-dimensions" is confirmed with POPULATIONS I and IV.

Hypothesis No. 3 - "That spatial ability will be acquired by a majority of spatially weak students during the normal course of their year of anatomy, but that a minority of spatially weak students will remain so" is demonstrated with ALL FOUR POPULATIONS.

Hypothesis No. 4 - "That the predictive validity of paper-and-pencil tests of spatial ability will decrease significantly with increasing time, as spatially inept students who commence their year of anatomy become more spatially competent during the course of studies" is confirmed using POPULATIONS I and II, in particular.

Hypothesis No. 5 - "That significant under-achievement in anatomy will be recorded for groups of students who

- (a) fail outright (in total marks) on diagnostic batteries of geometric spatial exercises; and/or
- (b) fail outright in one or more sub-tests which comprise a battery of geometric spatial exercises; and/or
- (c) draw more than one grossly disproportionate sketching error in a battery of diagnostic spatial exercises; and/or

(d) draw more than five mild sketching errors in the battery of diagnostic spatial exercises"

is confirmed with ALL FOUR POPULATIONS.

Hypothesis No. 6 - "That spatial ineptitude occurs only amongst anatomy students who fail anatomy or who gain a third class pass in the subject" is refuted with POPULATION II.

Hypothesis No. 7 - "That an anatomical spatial MCQ test will be a significantly better predictor of achievement in anatomy practical examinations than a geometric spatial battery" is confirmed with POPULATIONS I and II.

Hypothesis No. 8 - "That a spatial anatomical MCQ test will be a significantly better predictor of achievement in anatomy practical examinations than a non-spatial anatomical MCQ test" is also confirmed with POPULATIONS I and II.

## 6. SELECTED CASE STUDIES

Perhaps the most stimulating and intriguing part of the whole of the present investigation occurs when the marks of individual students, who are suspected of being spatially handicapped, are examined one by one against the background of information gathered about them through interviews, case studies and the method of illuminative evaluation. In this section, a

brief reference will be made to seven students, sampled from POPULATIONS I to IV. Additional observations are cited in Appendix K which contains a great deal of valuable case study material.

The empirical data relevant to CASE STUDIES 1 and 2 are set out in Table 4.15.

The first case study student records consistently significant deficits on spatial anatomical MCQs relative to non-spatial anatomical MCQs throughout his year, and his practical marks are always cause for concern. His overall year mark reaches a bare pass only on the strength of his good performances on the non-spatial MCQ items in anatomy. When interviewed at mid-year, he remarked that he found the Rotation of Cubes sub-test on the geometric battery incomprehensible. Even when handling models of a cone, a tile, a cylinder and a horse-shoe, and holding them to the window in an attempt to "see" the orthogonal sections, the student experienced great difficulties, and particularly long periods of time were recorded before he offered satisfactory answers in the Synthesis of Sections sub-test. This student confided that his dominant left hand had caused him so many problems with his writing that, before he left school, he had been referred to a psychologist who had diagnosed severe spatial ineptitude, and who had dissuaded the student from pursuing a career in engineering or even medi-

TABLE 4.15 Empirical data relevant to CASE STUDIES 1 and 2

CASE STUDY NO.	GEOMETRIC SPATIAL BATTERY SCORE	GROSS SKETCHING ERRORS?	SPATIAL MCQ % MINUS NON-SPATIAL MCQ %			PRACTICAL EXAMINATION SYMBOLS *		
			APRIL	JUNE	NOVEMBER	APRIL	JUNE	NOVEMBER
1	31%	YES	-11%	-13%	-8%	BP	FF	BP
2	23%	YES	-33%	-15%	-5%	FF	FF	F

\* BP = Borderline pass  
 F = Fail 40% - 49%  
 FF = Fail <40%

cine. That he managed to pass anatomy at all is probably a credit to his tenacity and purposefulness.

The second case study student in Table 4.15 appears to be even more handicapped than the first. She records a similar pattern of results, and also reaches a bare pass at the end of the year only on the strength of her good performances on the non-spatial MCQ items in anatomy. When interviewed, she remarked that it was impossible for her to visualize the blocks and cubes in the geometric battery accurately rotated, and complained strongly that in the anatomy practical examinations she was not allowed to pick up the specimens on display and rotate or invert them. She objected to the time limit of 50 seconds allowed with each specimen, and voiced her anguish at not knowing how other students could work out the required answer when the demonstration object was deliberately placed upside down by the examiners. Finally, she remarked how difficult she had found zoology practicals in an earlier year when she was required to draw three-dimensional diagrams, complete with dotted lines for perspective effect, which she was never able to accomplish.

The empirical data relevant to CASE STUDIES 3 and 4 are set out in Table 4.16. The pattern of results obtained by these two students are characteristic of many spatially weak stu-

TABLE 4.16 Empirical data relevant to CASE STUDIES 3 and 4

CASE STUDY NO.	GEOMETRIC SPATIAL BATTERY SCORE	GROSS SKETCHING ERRORS?	June MCQ Spatial %	June MCQ Non-Spatial %	June Prac. Exam. %	Nov. MCQ Spatial %	Nov. MCQ Non-Spatial %	Oct. Prac. Exam %
3	65%	YES	34	64	26	34	52	32
4	48%	YES	46	64	28	36	52	33

dents who fail examinations in anatomy. It is only by resolving the students' MCQ scores into 'spatial anatomical' and 'non-spatial anatomical', however, that the nature of their problem begins to emerge. Failing scores on the geometric battery, in practical examinations and on spatial MCQs contrast dramatically with satisfactory non-spatial performances in anatomy.

The empirical data relevant to CASE STUDIES 5 and 6 are presented in Table 4.17. These two students are representative of about a dozen students in each year who fail the geometric battery outright but who score well on all tests and examinations in anatomy. For a reason which has not yet been established, these students score well in practical work but significantly underachieve on spatial MCQs which require the visualization in imagination of the anatomical feature or structures concerned. The geometric battery usually detects these students, but practical examinations in anatomy, which appear to be highly spatial in nature, do not. This requires further investigation.

The final, and the most fascinating case study is set in the context of the performances of the 13 students comprising POPULATION II(R). Eleven of these students failed outright in 1980, manifesting significant spatial deficits in anatomical

TABLE 4.17 Empirical data relevant to CASE STUDIES 5 and 6

CASE STUDY NO.	GEOMETRIC BATTERY SCORE	JUNE MCQ's (57)			NOVEMBER MCQ's (120)			PRACTICAL EXAMINATION SCORES		FINAL YEAR MARK
		SPATIAL CORRECT (35)	NON-SPATIAL CORRECT (22)	DEFICIT	SPATIAL CORRECT (72)	NON-SPATIAL CORRECT (48)	DEFICIT	JUNE	NOV	
								80%	82%	
5	43%	57%	73%	-16%	72%	83%	-11%	80%	82%	74%
6	48%	54%	68%	-14%	57%	73%	-16%	64%	76%	66%

spatial MCQs, as well as failing in practical examinations and on the spatial geometric battery. By the end of their repeated year, however, all but four of these students appeared to have achieved at least minimal proficiency in anatomical spatial examinations. One of these four exceptions was a most unexpected case, and a summary of his performance during the two-year period is reproduced in Table 4.18.

This particular candidate was and still is a national chess champion, presumably able to think and visualize quickly, clearly and accurately in two dimensions. The natural assumption that he will be spatially competent in three dimensions is not only disproved; the student also appears to have an almost permanent spatial disability which even repeating a year of anatomy has failed to eradicate.

Another intriguing fact is that this student failed outright in all sub-tests of the geometric battery, except the first one, RV:Rotation and Visualization in Three Dimensions, for which he speedily gained almost full marks. How did he achieve this?

TABLE 4.18 Empirical data relevant to CASE STUDY no. 7

GEOMETRIC SPATIAL BATTERY SCORE	GROSS SKETCHING ERRORS?	YEAR	SPATIAL MCQ % MINUS NON-SPATIAL MCQ %			PRACTICAL EXAMINATION SYMBOLS*		
			APRIL	JUNE	NOVEM.	APRIL	JUNE	NOVEM.
46%	YES	NOVICE	- 27%	- 12%	- 7%	F	FFF	FF
			N/A	- 11%	- 13%	P	BP	FF
		REPEATING						

\* BP = Borderline pass  
 F = Fail 40% - 49%  
 FF = Fail 30% - 39%  
 FFF = Fail < 30%

If one re-examines this sub-test in the light of the student's two-dimensional prowess, the problem apparently resolves itself. Figure 4.1 is a sample item from sub-test RV which requires one of the blocks A, B, C, D or E to fit exactly into the uppermost block. To derive the correct answer, however, it is apparently not necessary to rotate any of the blocks through three full dimensions. By merely covering the master block at the top and rotating in the plane of the paper (that is, in two dimensions), each of the blocks A to E through about  $90^\circ$ , like a knight's move in chess, block C immediately becomes the obvious misfit - a technique and result which, although correct, was never the intention of the test designer. This suggested explanation, however, is a mere logical deduction. Since the student was not asked personally at the time, it remains speculative.

---

FOOTNOTE Throughout this discussion of the seven case studies, the confidential percentage marks obtained by students on university tests and examinations have been replaced by tabulated symbols in cases where the students referred to might be readily identifiable.

FIGURE 4.1     A sample item from the geometric spatial battery sub-test  
"Rotation and Visualization in Three Dimensions".

B. ( )

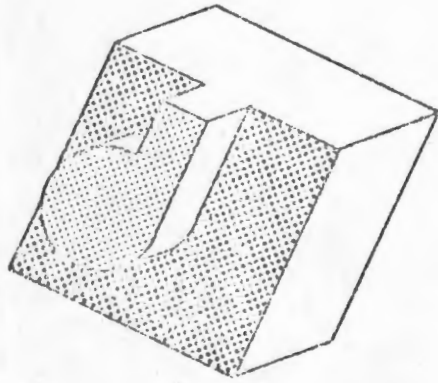
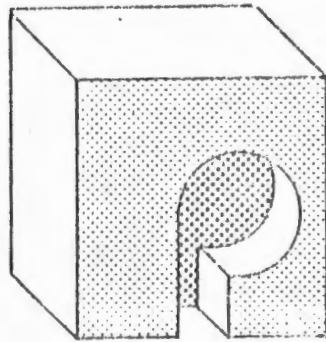

A.

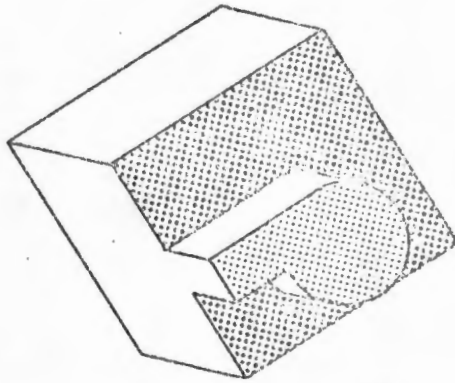

B.

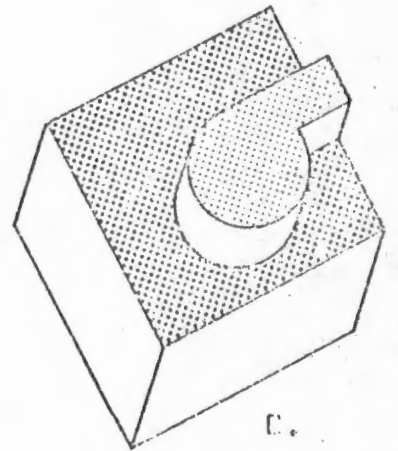

C.

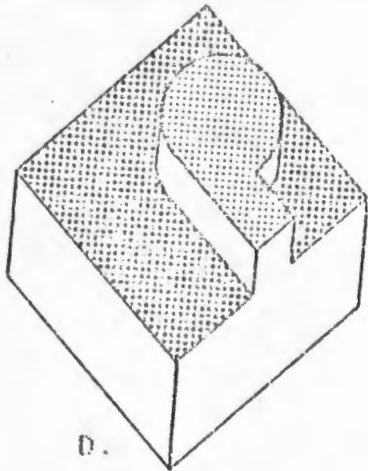

D.

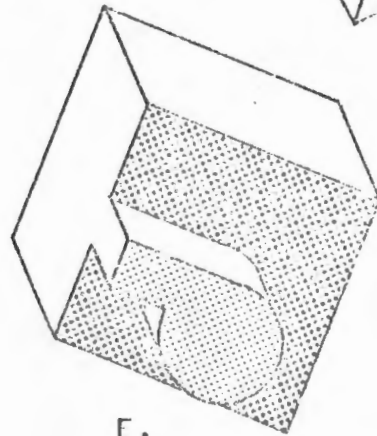

E.

**B. RESULTS : ASTRONOMY****1. EXPLORATORY FINDINGS WITH POPULATION V**

POPULATION V consisted of 27 science students attending a popular introductory second-year-level course in descriptive astronomy who were interviewed either individually or in pairs between 1979 and 1981. Discussing and probing students' astronomical spatial concepts by means of photographs and models, it was found that students experienced difficulties in the following areas :

- (i) visualizing lunar and planetary phases from different frames of reference;
- (ii) deriving the directions of the rotation and revolution of the Earth around the Sun from observation and reason;
- (iii) plotting the relative positions of stars in a constellation subsequent to its partial rotation in the sky;
- (iv) co-ordinating the positions in space of a revolving heavenly body and its axis of rotation;
- (v) co-ordinating in space the relative positions of the components of a binary star and the major and minor axes of its apparent orbit;

- (vi) visualizing the shapes of galaxies and orbits from changing frames of reference;
- (vii) explaining the retrograde loops of the outer planets against the background of constellations; and
- (viii) interpreting the light curves of variable stars.

Many misconceptions were recorded, and these helped to form the distracters in the MCQs on both the Novice Astronomical Spatial Test and the Full Astronomical Spatial Test filed in Appendix J. (The Novice Test consists of questions 1, 2, 3, 6, 8, 11, 12 and 17 of the Full Astronomical Spatial Test.) Examples of students' errors and misconceptions are reproduced in Appendix M.

## 2. THE PREDICTIVE VALIDITY OF THE MEASURES WITH POPULATION VI

POPULATION VI consisted of 55 novice students with intact scores attending the second-year course in descriptive astronomy at the University of Cape Town. These students were mass-tested at the commencement of their year, using both the battery of geometric spatial exercises and the Novice Astronomical Spatial Test constructed by the author.

Scores on the geometric battery ranged from 12% to 97%, with a mean of 66.5% (N=55). The pass mark adopted was that derived from the four populations of anatomy students - that is, 63%.

Scores on the Novice Astronomical Spatial Test ranged from 0% to 97%, with a mean of 49.4% (N=55). The pass mark was set at 44%.

13 of the 55 students failed simultaneously both the geometric spatial battery and the Novice Astronomical Spatial Test and, for predictive purposes, are labelled as "spatially handicapped".

30 of the 55 students passed both the geometric spatial battery and the Novice Astronomical Spatial Test and, for predictive purposes, are labelled as "spatially able".

The results obtained for the two groups on the first semester university examination in descriptive astronomy are presented in Table 4.19. It is found that the spatially handicapped group scores an average of 9.2% less than the spatially able group, which is a statistically significant deficit ( $p=0.01$ ). 8 of the 13 handicapped students failed, whereas only 10 of the 30 spatially competent students failed the first semester examination in astronomy.

Table 4.20 records the correlation coefficients between the dependent and independent variables for POPULATION VI. The correlation of  $r=0.61$  between the Novice Astronomical Spatial

Mean percentage recorded on the first semester class examination by the spatially handicapped and the spatially borderline sub-groups of POPULATION VI relative to the spatially competent sub-group of POPULATION VI using the geometric spatial battery given in March and the Novice Astronomical Spatial Test given in March as the criteria for spatial competence (N = 55)

	Students who were both Geometrically Spatially Handicapped and Astronomically Spatially Handicapped in March (N = 13)	Students who were Spatially Borderline either Geometrically or Astronomically in March (N = 12)	Students who were Geometrically Spatially Competent and Astronomically Spatially Competent in March (N = 30)
Mean scores for May Class Test in Astronomy (corrected for guessing)	48.3%	56.5%	57.5%
Mean % Drop Relative to the Spatially Competent Group	-9.2%**	-1.0%	-

\*\* Significant difference  $p < 0.01$

TABLE 4.20      Correlations between the scores obtained by POPULATION VI

(N = 55)

	Novice Astronomical Spatial Test (given in March)	Geometrical Spatial Battery (given in March)
First semester examination in Astronomy	0.33**	0.16
Geometric Spatial Battery (March)	0.61**	-

SIGNIFICANCE:

$r \geq 0.22$

$p < 0.05$

$r \geq 0.31$

$p < 0.01$

Test and the geometric spatial battery suggests, but does not prove, that both are measuring an ability to visualize in three dimensions, but in different contexts.

The correlations also indicate that the Novice Astronomical Spatial Test is a statistically significant ( $p < 0.01$ ) predictor of level of achievement on the first semester examination in descriptive astronomy, but that the purely geometric spatial battery is not, despite a significant ( $p < 0.01$ ) relationship between them.

Although both the geometric and astronomical spatial tests have significant diagnostic validity, nevertheless their predictive correlation coefficients are low with respect to performance level in descriptive astronomy. An analysis of the scores of the 55 students in POPULATION VI reveals that failure on both the geometric and astronomical spatial predictors occurs for students at almost all levels of achievement on the university examination in astronomy. The first semester astronomy marks of the spatially failing students range from 26% to 68%. This large spread of scores reduces the size of the predictive coefficients relating spatial ability to academic achievement scores, but does not invalidate the diagnostic purpose of the spatial tests which is to indicate those stu-

dents who are likely to under-achieve by about 9% at any level of performance in descriptive astronomy.

The results of the regression analyses performed on the data are reproduced in Table 4.21, firstly with the independent spatial variables separate, and secondly with the variables combined. In addition to confirming the significant contribution to the university examination scores made by the Novice Astronomical Spatial Test ( $t=2.50$ ), the  $R^2$  factor of 0.106 nevertheless indicates that little of the variance in the first semester astronomy examination scores is attributable to the scores on the March Novice Astronomical Spatial Test. The  $R^2$  factor of 0.108, obtained by including the scores on the geometric spatial battery as well, improves the figure by a negligible amount. Inclusion of the geometric battery scores in the multiple correlation coefficient scarcely improves this statistic either ( $r=0.325$  increases to  $r=0.328$ ).

It is concluded that a knowledge of the descriptive astronomy taught in the lecture course itself probably accounts for most of the variance in the scores obtained by students in the university astronomy examination; but that astronomical spatial ability does play a significant ( $p < 0.01$ ) role in modifying these marks.

TABLE 4.21 Results of the regression analysis performed on the dependent and independent variables for POPULATION VI.

```

REGGY .05
INPUT THE DEPENDENT VARIABLE ** MAY
INPUT THE INDEPENDENT VARIABLE ** AST
INPUT THE DEGREE OF FIT ** 1

```

TERM	COEFFICIENT		B/SIGMA(B)	CONFIDENCE INTERVAL	
	B	SIGMA(B)	T	LOWER	UPPER
B0	44.6902	4.4470	10.0496	35.7686	53.6117
B1	.2115	.0844	2.5048	.0421	.3809

THE THEORETICAL VALUE FOR T AT THE 0.025 LEVEL AND 53 DF = 2.006

## REGRESSION ANALYSIS TABLE

SOURCE	SS	DF	MS	F
TOTAL (CORRECTED)	7868.10909	54	145.70572	
REGRESSION (CORRECTED)	832.84203	1	832.84203	6.274
RESIDUAL	7035.26707	53	132.74089	
CORRECTION FACTOR	167145.89091	1		

MULTIPLE CORRELATION COEFFICIENT = .325  
R SQUARED FACTOR = .106  
THE SIGNIFICANCE OF REGRESSION = .9853  
(SIGNIFICANCE: AREA UNDER CURVE FROM 0 TO COMPUTED F)

TYPE 1 FOR MORE REGRESSION, 0 TO STOP \*\*

VM READ

```

REGGY .05
INPUT THE DEPENDENT VARIABLE ** MAY
INPUT THE INDEPENDENT VARIABLE ** GEO
INPUT THE DEGREE OF FIT ** 1

```

TERM	COEFFICIENT		B/SIGMA(B)	CONFIDENCE INTERVAL	
	B	SIGMA(B)	T	LOWER	UPPER
B0	48.6553	5.5737	8.7295	37.4733	59.8372
B1	.0973	.0802	1.2136	-.0636	.2582

THE THEORETICAL VALUE FOR T AT THE 0.025 LEVEL AND 53 DF = 2.006

## REGRESSION ANALYSIS TABLE

SOURCE	SS	DF	MS	F
TOTAL (CORRECTED)	7868.10909	54	145.70572	
REGRESSION (CORRECTED)	212.73459	1	212.73459	1.473
RESIDUAL	7655.37450	53	144.44103	
CORRECTION FACTOR	167145.89091	1		

MULTIPLE CORRELATION COEFFICIENT = .164  
R SQUARED FACTOR = .027  
THE SIGNIFICANCE OF REGRESSION = .7717  
(SIGNIFICANCE: AREA UNDER CURVE FROM 0 TO COMPUTED F)

TYPE 1 FOR MORE REGRESSION, 0 TO STOP \*\* 0

Cont/...

TABLE 4.21 (Cont.)

REGGY .05  
 INPUT THE DEPENDENT VARIABLE \*\* MAY  
 INPUT THE INDEPENDENT VARIABLE \*\* AST AND GEO  
 INPUT THE DEGREE OF FIT \*\* 1  
 TYPE 1 FOR CROSSTERMS, 0 IF NOT \*\* 0

TERM	COEFFICIENT		B/SIGMA(B)	CONFIDENCE INTERVAL	
	B	SIGMA(B)	T	LOWER	UPPER
B0	45.7851	5.5486	8.2517	34.6486	56.9217
B1	.2336	.1077	2.1692	.0175	.4497
B2	-.0329	.0981	-.3351	-.2297	.1639

THE THEORETICAL VALUE FOR T AT THE 0.025 LEVEL AND 52 DF = 2.007

REGRESSION ANALYSIS TABLE

SOURCE	SS	DF	MS	F
TOTAL (CORRECTED)	7868.10909	54	145.70572	
REGRESSION (CORRECTED)	848.00597	2	424.00299	3.141
RESIDUAL	7020.10312	52	135.00198	
CORRECTION FACTOR	167145.89091	1		

MULTIPLE CORRELATION COEFFICIENT = .328  
 R SQUARED FACTOR = .108  
 THE SIGNIFICANCE OF REGRESSION = .9497  
 (SIGNIFICANCE: AREA UNDER CURVE FROM 0 TO COMPUTED F)

TYPE 1 FOR MORE REGRESSION, 0 TO STOP \*\*

VM READ

Finally, only 5 out of the 55 students in POPULATION VI drew grossly distorted sketches on the geometric spatial battery. Their marks on the first semester examination in astronomy ranged from 40% to 75%. Clearly, the use of sketching errors for predictive purposes in this instance cannot be justified.

23 students, however, failed one or more sub-tests of the geometric spatial battery. Their mean score on the University examination in astronomy at the end of the first semester was 52.5%, compared with the class mean of 57.5% (N=55). The difference of 5% is, however, not statistically significant ( $p=0.20$ ).

3. THE DIAGNOSTIC VALIDITIES OF  
THE MEASURES WITH POPULATION VII

POPULATION VII consisted of 25 students in the 1983 descriptive astronomy course who had intact test and examination results. At the conclusion of their course in November, which all 25 students passed, they were given the author-constructed Full Astronomical Spatial Test (Appendix J), followed by the geometric spatial battery administered individually in December. Under these conditions the assumption was made that the content matter was known adequately by the students.

Scores on the geometric battery ranged from 20% to 97% with a mean of 69.8%. The pass mark adopted was 63% again.

Scores on the Full Astronomical Spatial Test ranged from 14% to 86% with a mean of 55.0% (N=25). An error analysis of the Full Astronomical Spatial Test appears in Appendix N. It was necessary to delete only question (9)(1) from the test due to an inversion of the answers to this item.

Table 4.22 records the correlation coefficients obtained between scores on the two end-of-year diagnostic spatial tests and marks on the May, July and September class tests, and on the November examination in descriptive astronomy. It is found that the Full Astronomical Spatial Test has excellent diagnostic and retrospective predictive validity, with correlation coefficients ranging from 0.83 to 0.87. In contrast, the coefficients for the geometric spatial battery range from only 0.06 to 0.48.

Despite its low predictive validity with respect to levels of performance in astronomy, the geometric battery still serves a useful supportive role in the diagnosis of under-achievement in astronomy. POPULATION VII was divided into spatially handicapped and spatially able sub-groups on the basis of performance on the Full Astronomical Spatial Test. Students classified as astronomically spatially handicapped scored between 22% and 50% (N=10), whereas those categorized as astronomical-

TABLE 4.22      Correlations between the scores obtained by POPULATION VII  
on the tests and examinations in astronomy and the November  
and December spatial batteries      (N = 25)

	Full November Astronomical Spatial Test	Geometric Battery (December)
Test 1 (May)	0.84	0.48
Test 2 (July)	0.83	0.06
Test 3 (Sept.)	0.86	0.18
November Examination Section A	0.87	0.12
November Examination Section B	0.85	0.23
Geometric Battery (December)	0.60	-

SIGNIFICANCE : 'r  $\geq$  0.22      p < 0.05  
                   r  $\geq$  0.31      p < 0.01

ly spatially able scored between 64% and 86% (N=11), on the Full Astronomical Spatial Test given in November.

The results are recorded in Table 4.23. The spatially competent students score significantly higher marks on the May and September class tests in descriptive astronomy, on Section A of the November examination, and on the average total mark in descriptive astronomy. They also score significantly better on the geometric spatial battery ( $p < 0.001$ ), which supports its use as a corroborative diagnostic instrument.

It is concluded that the POPULATION VII students who were spatially handicapped in astronomy experienced a significant average deficit of more than 7% throughout 1983 on the tests and examinations set in descriptive astronomy.

These spatially handicapped students were by no means all potential failures in astronomy. As in anatomy, spatial ineptitude in astronomy was found at all levels of achievement on departmental tests and examinations.

Finally, only 2 students out of the 25 in POPULATION VII drew grossly distorted sketches on the geometric spatial battery, so no conclusions can be drawn. On the Full Astronomical Spatial Test administered in November, however, 16 of the 25

TABLE 4.23

Mean percentage drops recorded on tests and examinations in astronomy by the spatially handicapped sub-group of POPULATION VII relative to the spatially competent sub-group of POPULATION VII using the Full November Astronomical Spatial Test as the criterion for separating the two groups.

	MEAN SCORES FOR CLASS TESTS IN ASTRONOMY			MEAN CLASS TEST TOTALS %	ASTRONOMY EXAMINATION : MEAN SCORES FOR NOV.		MEAN MARK TOTALS %	YEAR'S MEAN FINAL MARKS %	MEAN GEOMETRIC BATTERY SCORE DECEMBER %
	MAY %	JULY %	SEPT. %		SECT. A %	SECT. B %			
ASTRONOMICALLY SPATIALLY HANDICAPPED (NOV. RAW SCORE 3 TO 11) N = 10	70.8	69.2	64.0	68.0	66.3	65.6	66.6	65.9	59.0
ASTRONOMICALLY SPATIALLY COMPETENT (NOVEMBER RAW SCORE 14 TO 19; MAX. = 22) N = 11	78.2	73.5	73.5	75.1	79.7	68.6	73.8	72.8	83.3
MEAN % DROP	-7.4%*	-4.3%	-9.5%*	7.1%*	-13.4%**	-3.0%	-7.2%*	-6.9%	-24.3%**

\* Significant difference  
 \*\* Significant difference

p < 0.05  
 p < 0.01

students drew more than one gross sketching error, examples of which are reproduced in Appendix M. All 16 students failed the Full Astronomical Spatial Test. It is concluded that not only is an astronomical spatial test the best instrument for diagnosing spatial ineptitude amongst astronomy students, but that a small section of this test could well require students to make sketches of astronomical bodies and constellations seen from changing frames of reference.

4. SUMMARY OF THE FINDINGS WITH POPULATIONS VI AND VII

The findings obtained with the astronomy students may be summarized by saying that the following hypotheses were either confirmed or lacked sufficiently strong statistical support:

HYPOTHESIS No. 9 - "That under-achievement in class tests and examinations in descriptive astronomy is significantly related to performance scores on paper-and-pencil tests of spatial ability." was confirmed with POPULATIONS VI and VII in the following respects :

- (a) For students who failed outright (in total score) on a diagnostic battery of geometric spatial exercises;
- (b) For students who failed outright on the predictive Novice Astronomical Spatial Test;

- (c) For students who failed outright on the diagnostic Full Astronomical Spatial Test; and
- (d) For students who drew more than one grossly disproportionate sketch on the Full Astronomical Spatial Test.

The hypothesis was not confirmed statistically in the following respects :

- (e) For students who failed outright in one or more sub-tests comprising the battery of geometric spatial exercises; and
- (f) For students who drew more than one grossly disproportionate sketching error in the geometric spatial battery.

HYPOTHESIS No. 10 - "That spatial ineptitude occurs only amongst astronomy students whose performance on university class tests and examinations is consistently below average" was refuted with both POPULATION VI and POPULATION VII.

HYPOTHESIS No. 11 - "That the Novice Astronomical Spatial Test will be a better predictor of achievement in descriptive astronomy than the geometric spatial battery" received support only at the significance level  $p = 0.10$  with POPULATION VI.

HYPOTHESIS No. 12 - "That the Full November Astronomical Spatial Test will be a significantly better diagnostic measure of spatial ineptitude in astronomy than the geometric spatial battery" was confirmed with POPULATION VII ( $p < 0.001$ ).

C. RESULTS : ENGINEERING

POPULATION VIII consisted of 275 first year novice engineering students who were mass-tested using the geometric spatial battery in March 1983, that is, at the commencement of their course.

Scores on the geometric battery ranged from 0% to 100%, with a mean of 77.0% (N=275). Once again a pass mark of 63% was adopted for the spatial battery.

Since Matriculation marks are confidential, only symbols for Matriculation mathematics and the Matriculation aggregate were available.

1. THE PREDICTIVE VALIDITY OF THE MEASURES WITH POPULATION VIII

(a) The predictive validity of the geometric spatial battery

Approximately one sixth of POPULATION VIII failed the geometric spatial battery outright in March (N=46), so, for the purpose of statistical analysis, the whole of the

engineering class was divided into sixths on the basis of increasing geometric battery score.

The effectiveness of the spatial battery for predicting the June and November examination results at all levels in engineering drawing, and particularly for diagnosing and predicting likely failures, is manifested in Tables 4.24 and 4.25 respectively.

The results are clear-cut. 44 of the 46 students who failed the geometric spatial battery in March attempted the June examination. These students' marks reveal an average deficit of more than 20% relative to the mean performance of the adjacent sixth of the class who were just borderline on the spatial battery (Table 4.24). Of the 44 students who failed the spatial battery outright in March, 31 failed in June and 2 were absent - that is, fully three-quarters of this lowest scoring group could have been offered remedial assistance, with justification, from the beginning of the academic year.

Whilst students scoring less than 63% on the March spatial battery were considered to have failed it outright, the sub-set of 20 students who scored less than 50% on

**TABLE 4.24** The effectiveness of the UCT March 1983 spatial battery for predicting the June 1983 engineering drawing test results, with the class divided into sixths according to decreasing March spatial performance.

MARCH SPATIAL BATTERY SCORES			JUNE TEST RESULTS								
			AVERAGE JUNE %	AV. JUNE % DROP BETWEEN INTERVALS	NO. OF STUDENTS IN EACH CLASSIFICATION						
Performance Intervals	%	N			1	2+	2-	3	F (30-49)	FF (<30)	Absent
Excellent	100-93	46	77,1	-	27	6	12	1	0	0	2
Very Good	93-86	46	72,9	4,2% Drop	22	12	7	3	2	0	0
Good	85-80	46	68,4	4,5% Drop	17	6	14	4	4*	1	0
Satisfactory	80-74	46	66,2	2,2% Drop	13	5	13	11*	4	0	0
Borderline	73-63	46	61,5	4,7% Drop	12	4	12	8	9	1	0
Outright Fail	61-0	44	41,1	20,4% Drop	2	1	6	4	15*	16	2

274

Each cell with an asterisk contains one 1982 student who repeated the course in 1983. (Six other students repeating Engineering Drawing in 1983 were absent during the spatial testing in March. Their results are not included in the above table).

**TABLE 4.25** The effectiveness of the UCT March 1983 spatial battery for predicting the November 1983 engineering drawing examination results, with the class divided into sixths according to decreasing March spatial performance.

MARCH SPATIAL BATTERY SCORES			NOVEMBER 1983 EXAMINATION RESULTS						
			NO. OF STUDENTS IN EACH CLASSIFICATION						
PERFORMANCE INTERVALS	%	N	1	2+	2-	3	FS	FR	ABS
Excellent	100-93	47	32	8	6	1	0	0	0
Very Good	93-86	47	22	7	9	6	1	1	1
Good	85-80	46	15	8	13*	5	3	1	1
Satisfactory	80-74	46	12	8	12	8*	3	1	2
Borderline	73-63	46	10	3	17	9	3	2	2
Outright Fail	61-0	46	2	0	7	14	(5)	(11)*	(7)

278

Each cell with an asterisk contains one 1982 student who repeated in 1983.

the March spatial battery fared even worse in June. The average June mark for these 20 students (who constituted the spatially poorest sub-group in March) was depressed to 34.0% (compared to 61.5% for the students who were merely borderline on the March spatial battery). There appears little doubt as to the diagnostic value of the geometric spatial battery for novice engineering drawing students.

At the other end of the performance scale a similar predictive effect occurs- that is, three-quarters of students who performed in the top sixth on the March spatial battery subsequently pass with distinction in June (Table 4.24).

In general, the better a student's performance on the March spatial battery, the better were that student's chances of scoring a first class pass in June. Any possible causal relationship, however, is blurred by the effect of learning which may have occurred between March and June, even for certain students who under-performed on the March spatial battery. The correlation between the geometric battery and the June examination scores is  $r=0.65$  ( $N=273$ ), and possibly reflects, in part, this learning effect.

By November 1983 (Table 4.25), some improvement has occurred, but the overall pattern of results remains the same. 46 students failed the spatial battery outright in March. By November 37 of these have either dropped out of the course as a result of their bad failure in June, or have recorded FR or FS in November, or have gained a third class pass. Thus, more than 80% of identifiable students who failed the geometric spatial battery in March could have benefited from special academic support from the commencement of their course.

All 7 students in Table 4.25 who failed the geometric battery in March, and who were absent for the November examination, scored less than 40% in the June examination. They may have dropped out of the course because of spatial handicaps.

All 11 students in Table 4.25 who failed the March spatial battery, and who are classified as FR in November, scored less than 56% for the geometric battery.

Some students who failed the March spatial battery improve their performances in engineering drawing between June and November. Whereas 33 of the spatially weak students failed (or were absent) in June (Table 4.24), by

November, only 23 of these students have dropped out or failed - that is, 10 more students now pass (Table 4.25).

The correlation between the geometric spatial battery given in March and the November examination results in engineering drawing is  $r=0.62$  ( $N=243$ ).

- (b) A comparison of the diagnostic and predictive validities of the the Matriculation mathematics symbol, the Matriculation aggregate and the geometric spatial battery

Tables 4.26(i) and 4.26(ii) record the relative diagnostic importance of below-average performance in Matriculation mathematics and outright failure on the geometric spatial battery, with respect to subsequent failure in the June and November examinations respectively.

Whereas the March geometric spatial battery correctly identifies 61% of the students who fail in June, the Matriculation mathematics symbol identifies only 21% of these failures.

Similarly, the March geometric battery identifies 44% of students who fail in November or who are absent or with-

TABLE 4.26 Relationships between failing performance in the June engineering drawing examination and (a) below average performance in matriculation mathematics, and (b) outright failure on the March spatial battery.

	No. of students with known D or E symbols for matric. maths.	No. of students failing outright on the March spatial battery
	34	44
No. of students subsequently failing the June examination	7 = 21%	27 = 61%

TABLE 4.26 (ii) Relationships between failing performance in the November engineering drawing examination and (a) below average performance in matriculation mathematics; and (b) outright failure on the March spatial battery.

	No. of students with known D or E symbols for matric. maths.	No. of students failing outright on the March spatial battery
	33	46
No. of students subsequently failing the November examination (or absent / withdrawn)	Failing + absent/ withdrawn 4 + 2 = 6 = 18%	Failing + absent/ withdrawn 13 + 7 = 20 = 44%

drawn, whilst the Matriculation mathematics symbol identifies only 18% of these students.

A correlation matrix (Table 4.27) has been computed for the 185 students out of the 275 novices comprising POPULATION VIII who have intact data for all five variables (namely, the geometric spatial battery, the Matriculation mathematics symbol, the Matriculation aggregate symbol, the June engineering drawing examination and the November engineering drawing examination).

The results indicate that the Matriculation aggregate is significantly related to performance in engineering drawing in both June and November, but that the Matriculation mathematics symbol is not. The geometric spatial battery, however, remains the single best predictor of achievement scores in engineering drawing, being strongest, incidentally, with the prospective chemical engineers ( $r=0.80$  and  $r=0.72$  for June and November, respectively), and lowest with the prospective electrical engineers ( $r=0.42$ ), and mechanical engineers ( $r=0.38$ ) in June 1983. This finding is the reverse of that reported by Blade & Watson (1955) as reported earlier in Chapter 2.

TABLE 4.27 Correlation matrix for 185 engineering drawing students with complete data for 1983.

	MARCH SPATIAL BATTERY	MATRIC MATHS SYMBOL	MATRIC AGGREGATE SYMBOL	JUNE TEST	NOVEMBER EXAM SYMBOL
MARCH SPATIAL BATTERY	1,00	-0,02	0,19	0,54*	0,52
MATRIC MATHS SYMBOL		1,00	0,12	-0,01	0,00
MATRIC AGGRE- GATE SYMBOL			1,00	0,27	0,36
JUNE TEST				1,00	0,77
NOVEMBER EXAM SYMBOL					1,00

Footnote: \*  $r = 0,65$  for the whole Engineering Drawing class (N=273).

Significant Correlations:  $r \geq 0,14$   $p < 0,05$

A regression analysis was carried out on the data for the 185 engineering drawing students with intact scores on the two dependent variables (the June and November examination results) and three independent variables (the geometric battery, the Matriculation mathematics symbol and the Matriculation aggregate). A regression analysis indicates the best way of combining for predictive purposes the students' scores on the three independent variables.

The results of the analysis are set out in Tables 4.28 and 4.29. It is found that, for the 185 students with intact scores, the resulting predictive multiple correlations are little better for predicting June and November examination performance than the single correlations obtained using the geometric spatial battery on its own. The geometric battery scores alone account for 54.3% of the variance in the June examination marks; addition of the remaining independent variables increases this figure to only 57.0%. The corresponding figures for the amount of variance predicted in the final November examination marks are 51.5% increased to 57.9%, respectively.

The regression analysis also indicates that it is the statistically significant Matriculation aggregate which

TABLE 4.28     Results of the regression analysis on the intact scores of 185 engineering students using only spatial test score as the independent variable

TOTAL CLASS

JUNE

Using only Spatial Test score as the independent variable.

Equation

$$y = 23,633 + 0,5554x_1$$

T Statistic

$b_1$	8,748	*	$r^2 = 0,543$
-------	-------	---	---------------

NOVEMBER

Using only Spatial test score as independent variable.

Equation

$$y = 30,89 + 0,453x_1 \qquad r^2 = 0,515$$

T Statistic

$b_1$	8,1193	*	7	1,973
-------	--------	---	---	-------

\* Significant at 5% level.



causes the marginal increases in the predictive multiple correlations. The small negative coefficients for the Matriculation mathematics symbol indicate multicollinearity problems with the data.

(c) The diagnostic validity of the sub-tests of the geometric spatial battery

Merely noting the names of engineering students who failed in one or more of the battery's sub-tests in March is not an effective means of diagnosing likely failures in the June examination. 70 students failed one or more geometric sub-tests in March. Of these, 36 passed in June and 34 failed in June.

It is concluded that, for students of engineering drawing, the total score on the battery of geometric spatial exercises, rather than sub-test failures, is the critical predictor of subsequent performance in this subject.

(d) The diagnostic validity of gross sketching errors with students of engineering drawing

28 students out of the 278 who attempted the geometric spatial battery in March 1983 drew grossly disproportionate sketches in their answers to the sub-tests SYN and SEC. 18 of these 28 students subsequently passed the June examination.

It is concluded that, for students of engineering drawing, the total score on the battery of geometric spatial exercises, rather than the occurrence of grossly distorted sketches, is the critical predictor of subsequent achievement in this subject.

2. THE SAMPLING VALIDITY OF THE MEASURES

An interesting discrepancy has been pointed out in Table 4.27 with regard to the correlation coefficient obtained between scores on the March spatial battery and marks on the June engineering drawing examination. For the whole of POPULATION VIII, the correlation is  $r=0.65$  ( $N=273$ ) but, for the students with intact data during 1983, the correlation obtained is only  $r=0.54$  ( $N=185$ ). This discrepancy may be partly attributable to random sampling.

To investigate this possibility, the 273 students were randomly divided into two groups on the alphabetical basis of surname initials. 142 students had surnames from A to L, and 131 from M to Z. The following correlations between scores on the geometric spatial battery and the June examination were obtained :

Surnames A to L     $r=0.59$     (N=142)

Surnames M to Z     $r=0.67$     (N=131)

This finding is important since it provides a guide to margins of error which may occur in other correlation coefficients, such as those obtained with the POPULATION II anatomy students (N=154).

With smaller groups of students such as those in POPULATION I (N=38), POPULATION IV (N=19), POPULATION VI (N=55) and POPULATION VII (N=25), wider sampling errors may be expected in the results reported earlier in this chapter.

To investigate this possibility further, the 273 engineering students comprising POPULATION VIII were randomly sub-divided into 10 groups of 24 students, plus one group of 33 students on the alphabetical basis of surname initials. Correlations between the scores on the geometric spatial battery and the

June examination marks in engineering drawing were re-calculated for each of these sub-groups, and the findings are recorded in Table 4.30.

The range of correlation coefficients obtained for these samples of 24 students is great. The lowest is  $r=0.38$  ( $N=24$ ) which, statistically, is not significant. The highest is  $r=0.94$  ( $N=24$ ) which is nearing perfection. These findings illustrate that many of the results reported in this chapter with small populations are likely to be surrounded by large margins of error, and cannot always be taken at face value, except perhaps when all the trends are in the same direction for a given population.

### 3. SUMMARY OF FINDINGS WITH POPULATION VIII

The findings obtained with the engineering students may be summarised by saying that the following hypotheses were either confirmed or refuted by the data gathered :

HYPOTHESIS No. 13 - "That under-achievement in the first semester examination and in the final examination in engineering drawing is significantly related to performance scores on paper-and-pencil tests of geometric spatial ability" was confirmed with POPULATION VIII in the following respects :

TABLE 4.30 Random variations in the predictive validity coefficient of the March 1983 spatial battery ( $r=0,65$ ;  $N=273$  for the June 1983 engineering drawing test results), which result when the 273 students are sub-divided alphabetically into groups of 24.

<u>SURNAME INITIALS</u>	<u>N</u>	<u>r</u>	
A - B	24	0,52	
B - D	24	0,59	
D - G	24	0,52	
G - H	24	0,48	
H - K	24	0,58	
K - M	24	0,71	
M - M	24	0,48	
M - P	24	0,94	Highest
P - R	24	0,38	Lowest
R - S	24	0,77	
<u>S - Z</u>	<u>33</u>	<u>0,61</u>	
<u>A - Z</u>	<u>273</u>	<u>0,65</u>	

(For  $r > 0,42$   $p < 0,05$ )

- (a) (i) For students who failed outright (in total score) on a diagnostic battery of geometric spatial exercises; and
- (ii) For students at all levels of performance on the battery of geometric spatial exercises.

The hypothesis was not confirmed in the following respects :

- (b) For students who failed outright in one or more subtests of the geometric battery; and
- (c) For students who drew more than one grossly disproportionate sketching error in the geometric battery.

HYPOTHESIS No. 14 - "That the geometric spatial battery scores contribute significantly more to the variance in the university examination marks in engineering drawing than either the Matriculation mathematics symbols or the Matriculation aggregate symbols" was confirmed.

## CHAPTER FIVE

### DISCUSSION OF RESULTS

In this chapter the discussion of results takes place in four stages. Following a few, brief, preliminary remarks, the discussion proceeds to examine in detail the strengths and weaknesses, and the advantages and disadvantages of subject-based spatial MCQs and the geometric spatial battery which are pivotal to the findings recorded. After this, the experimental design employed in the present investigation is scrutinized, and, finally, the implications and recommendations of the findings for further research are set out.

#### OPENING REMARKS

In the story A Scandal in Bohemia, Sherlock Holmes says :

It is a capital mistake to theorize before one has data. Insensibly one begins to twist facts to suit theories, instead of theories to suit facts.

Data uncovered during the current investigation have resulted in the recording of certain unanticipated findings. Previous studies with astronomy students, for example, have established the existence of significant relationships between geometric spatial

ability and academic achievement in topics dealing with positional and projective astronomy (for example, Schatz, 1978; Kelsey, 1980; Bishop, 1980; and Sonntag, 1981). The author did not expect, however, that under-performance on tests of spatial ability would be associated with significant under-achievement in a course of astronomy designed to be purely descriptive in nature; yet this occurred for the two consecutive years investigated. It would appear that the ability to visualize positions and rotations in three dimensions is an important pre-requisite for understanding the content of descriptive astronomy, even when this is not explicitly examined.

A second unexpected finding with both the anatomy and astronomy students was that, even after a year of intensive study in these subjects, some students appear to manifest only a rudimentary appreciation of three-dimensional relationships, whether geometrically, anatomically or astronomically. Their visual disability appears to be deeply ingrained in their cognitive functioning, and relatively untouched by normal teaching processes at university level. It seems scarcely credible that students who gain "A" aggregates in Matriculation (that is, over 80%) and, therefore, would appear to be capable of a high degree of abstract thinking, might need to be taught using specially designed, concrete, remedial materials. These findings surely have implications for Piaget's theory of cognitive functioning, which tends to classify thinkers

as essentially concrete or essentially formal past the age of 18 years.

A third unexpected finding occurred with the students of engineering drawing. Blade & Watson (1955) found that the predictive validity of a battery of geometric spatial tests was greatest with prospective mechanical and electrical engineers, and least with prospective chemical engineers. The present investigation (1983) found the reverse trend, so this aspect of the research is being replicated in 1984 prior to the publication of these findings.

Winn (1982:20-21) has recently pointed out the directions in which he believes that cognitive-based research into visualization in learning and instruction should proceed. He writes :

It seems fair to say that because the cognitive approach tackles the great complexities of learning processes, it offers a more complete account of learning ... Designers will have to start thinking and designing in terms of cognitive processes, rather than in terms of overt learner performance, and this will require that they be aware of cognitive research ... Future research will have to address the questions of cognitive processes and instructional strategies simultaneously.

The findings of the present study appear to support these assertions.

ADDITIONAL REFLECTIONS ON THE EFFECTIVENESS OF THE  
GEOMETRIC SPATIAL BATTERY AND SUBJECT-BASED SPATIAL  
MCQs FOR DIAGNOSTIC AND PREDICTIVE PURPOSES

In an investigation into spatial factors affecting results in an engineering drawing and design course, Taylor (1983:19;32) indicates that the prediction of individual scores is extremely complex, especially if students who attempt batteries of geometric spatial tests are unmotivated. He recommends that ways be found to optimize the motivation of all students on spatial tests if individual predictions are to be made.

The present investigation appears to have partially succeeded in this goal by

- (a) making the measurement of students' spatial abilities in anatomy part of the normal regular, university examining programme, using MCQs separated into spatial and non-spatial types, when students are likely to be most highly motivated; and
- (b) inviting students who fail academically by mid-year to attempt one or more of the batteries of geometric spatial tests.

The fact that from 1980 to 1983 more than 90% of these anatomy students arrived voluntarily at the times appointed for the testing indicates that gentle persuasion, coupled with the prospect of outright failure on the year as a whole, can be sufficient motivation for co-operation.

The innovative technique of using deficits on subject-based spatial MCQs relative to non-spatial MCQs for diagnostic purposes, however, has several weaknesses :

1. It works best when spatial and non-spatial items occur with approximately equal frequency on an MCQ examination paper.
2. Since many failing students are likely to score low marks on MCQ tests, the technique is subject to wide margins of error unless there are at least 50 or 60 items on each test, even allowing for the removal of some items due to inversions, and other items due to uncertainty about the correct classification of their spatial nature.
3. Occasionally a spatially handicapped student actually scores better on spatial MCQs than on non-spatial MCQs - for instance, when the non-spatial MCQs sample subject matter which is unfamiliar to that particular student. Hence, if individual predictions are to be made, more than one spatial/non-spatial MCQ test should be given over a period of one to two months.

Turning to the strengths and limitations of the battery of geometric spatial exercises in the current study, one can begin by noting its various correlations with academic results in different discip-

lines. With whole classes these are generally in the range 0.60 to 0.70 (N=+370) for engineering drawing; 0.10 to 0.20 (N=55) for descriptive astronomy; 0.10 to 0.30 (N=154) for practical anatomy; and 0.05 to 0.15 (N=154) for anatomical spatial MCQ performance.

Low correlations with whole classes have, in the past, been characteristic of most investigations into spatial ability (with the obvious exception of Technical Drawing and its closely allied subjects). Many researchers have noted them with somewhat apologetic disappointment or resignation - for example, Crow & Piper (1983;540), and Just (1979:32) who writes :

The significant correlations reported in this study are generally in the .25 to .35 range. It can be argued that correlations of this magnitude, while significant, are not actually important. A correlation of .335 only accounts for 11% of the variance. In reviewing the statistics reported in the studies cited in the literature review, one finds similar correlations.

There are primarily two reasons why this occurs. First, the prediction of grades or results on a test is very difficult since so many factors enter into the grading process; secondly, the DAT-PMAT test was used as a criterion for selection into the dental school, and therefore this study examines only a relatively homogeneous population which falls within a narrow bandwidth on this measure. Given these limitations, correlations of the order of .3 are important in these types of studies.

Dissatisfied with such attempts to explain away the existence of relatively low correlations between geometric spatial ability and academic performance in a given subject, the present investigation has established that spatially handicapped students are commonly

found at virtually all levels of academic achievement from failure through to distinction. It is this situation which tends to lower the correlation coefficient appreciably. When both spatially able and spatially weak students who are passing their university examinations are removed from the population under study, correlations of 0.10 to 0.30 (N=154) may rise to 0.55 (N=37 academic failures), to use the practical anatomy example. These correlation coefficients may be further increased from 0.60 to 0.80 by changing the geometric spatial battery into an anatomical spatial test; or increased from 0.80 to 0.90 in the case of astronomy students by changing the geometric battery into a full astronomical spatial test.

Clearly, the magnitude of the correlation coefficients between spatial ability and level of academic performance vary so much, (depending on the nature, composition and size of the target population, and the nature, composition and length of the spatial tests adopted), that their interpretation appears to be more important than their actual size. For instance, even batteries of tests having very low correlations with level of academic achievement, have been shown in the present study to be very significant discriminators between spatially opposed groups of students within large populations. This would appear to be a noteworthy result.

Nevertheless, the use of a battery of geometric spatial exercises in an investigation such as the present one, cannot escape critical reflection.

With regard to the nature and composition of the geometric battery, the optimum number and type of sub-tests comprising the battery has still to be resolved. The use of solid demonstration test models, rather than paper-and-pencil tests with drawings, has not been explored. The standardized Blox Test and H Test used by Taylor (1980;1983) with university engineering students, should be validated with anatomy and astronomy classes.

Particularly unsettling is the finding that gross sketching errors made on the geometric battery (which, presumably, is subject-independent), can be used to identify spatially handicapped anatomy students, but not spatially inept engineering drawing students.

Perhaps the most serious concern with the author-designed spatial battery is that enunciated by Borich & Bauman (1972) who compared statistically the French and the Guilford-Zimmerman measures of spatial orientation and spatial visualization factors. They found that variance due to authorship was greater than variance due to the traits themselves. It is possible that this finding may also apply to the geometric spatial battery utilized in the current study.

Additional problems concern the marking of the geometric spatial battery. Firstly, in many cases, two students obtained the same global mark for the battery, yet their patterns of correct answers and errors and omissions were entirely different. Can one then say that their spatial competencies are truly numerically equal? Secondly, should a student who fails outright in one or more subtests of the battery be additionally negatively penalized in total score? If so, by how much? Thirdly, it was found that, when no time limits were imposed on answering the spatial battery, many students who scored full (or almost full) marks were below average on time-to-completion. Should their scores have been correspondingly penalized? Clearly, by arguing one way or the other in all these cases one can almost arbitrarily assign whichever spatial marks one chooses to a particular group of students, and thus statistically "prove" a hypothesis in almost any way one wishes. Such possibilities do tend to undermine the predictive and diagnostic validities of a battery of spatial tests.

Finally, it was found that, from year to year, fully one-third of all novice anatomy students manifest significant spatial ineptitude which is clearly revealed in their performances on tests and examinations conducted throughout their year of study. In descriptive astronomy, one quarter of the class and, in engineering drawing, the bottom one-sixth of the class (from a spatial point of view) is likely to need remedial assistance from the commencement of the

course. This illustrates the importance of establishing norms for populations of students in different scientific disciplines, as part of the process of validating diagnostic materials and remedial teaching procedures.

A CRITIQUE OF THE SCIENTIFIC MODEL OF  
INVESTIGATION EMPLOYED IN THE PRESENT STUDY

Although the current investigation has adopted a classical ex post facto empirical research method, it has also attempted to widen its exploratory base by incorporating aspects of the illuminative evaluation model (Parlett & Hamilton, 1972), case studies and clinical interviews into its research strategy.

One of the weaknesses of ex post facto studies is that the findings simply illustrate the hypotheses; they do not actually test them. Furthermore, a relationship noted may actually exist, but it is not necessarily the only relationship, nor is it, perhaps, the crucial one.

Parlett & Hamilton (1972) advocate the use of illuminative evaluation to take into account the wider contexts in which educational programmes function. Its primary task is description and interpretation rather than measurement and prediction, although these last two concerns are not excluded from the approach. The illuminative

evaluation model has not been fully deployed in the current investigation, but an attempt has been made to overcome the shortcomings of empirically-based research which Parlett & Hamilton fault in the following five ways :

OBJECTION No. 1

Rarely can 'tidy' results be generalized to an 'untidy' reality. Whichever approach is used, there is a tendency for the investigator to think in terms of 'parameters' and 'factors' rather than 'individuals' and 'institutions'. Again, this divorces the study from the real world (pages 5-6).

COMMENT - The present investigation has, indeed, studied not only different subject disciplines and classes of students by name, it has also traced the spatial development of hundreds of students one by one from month to month, from term to term, and even from year to year on an individual basis. The problem is, indeed, a real one for many university students.

OBJECTION No. 2

Before-and-after research designs assume that innovating programmes undergo little or no change during the period of study. This built-in premise is rarely upheld in practice (page 6).

COMMENT - On the contrary, the present investigation has assumed that changes will occur from month to month during the period of study, and has attempted to monitor some of the more important variables, even changing or deleting or re-defining these mid-stream during the longitudinal studies conducted.

OBJECTION NO. 3

The methods used in traditional evaluations impose artificial and arbitrary restrictions on the scope of the study. For instance, the concentration on seeking quantitative information by objective means can lead to neglect of other data, perhaps more salient to the innovation, but which is disregarded as being 'subjective', 'anecdotal' or 'impressionistic' (pages 6-7).

COMMENT - The case studies reported for the anatomy students in the present investigation appear to support the importance of these assertions.

OBJECTION NO. 4

Research of this (empirical) type, by employing large samples and seeking statistical generalizations, tends to be insensitive to local perturbations and unusual effects. Atypical results are seldom studied in detail. Despite their significance for the innovation, or possible importance to the individuals and institutions concerned, they are ironed out and lost to discussion (page 7).

COMMENT - From the beginning of the present investigation, which commenced with the clinical interviewing of individuals, it has been the atypical results which have attracted particular attention, generating new hypotheses and new lines of investigation, for example, in the design of spatial test items, and in new interpretations of data.

OBJECTION NO. 5

Finally, this (empirical) type of evaluation often fails to articulate with the varied concerns and questions of participants, sponsors and other interested parties (page 7).

COMMENT - All students who took part in clinical interviews, or who were mass-tested with the geometric spatial battery, were encouraged to ask questions or to express their concerns at the end of the testing session. Some requested further telephone consultations; others asked that their spatial scores be made known to them privately, rather than publically; others criticised the wording of certain questions; others volunteered details of their life history; and so on.

Approximately 100 pages of hand-written notes were transcribed from tape recordings made with such students, and these formed the basis of the sample case studies reported in Chapter 4. A concerted effort has been made to be concerned with "real" events, in "real" contexts in "real" time, and to be concerned with the meanings of spatial events for students, as distinct from a concern to measure "behaviour" (Millar, 1983:117).

What characterises case study research is the capacity of the process to generate question after question, often in unpredictable forms. For example, should medical students who suffer a severe and lasting three-dimensional disability be allowed to continue their undergraduate studies on the understanding that they will subsequently specialize in a relatively non-spatial area like psychiatry or dietetics? Should a larger or a smaller fraction of

MCQs in anatomy examinations be non-spatial in nature? Should spatially handicapped students be given longer periods of time in practical anatomy examinations? Should the geometric spatial battery scores be marked according to a confidence-rating scale? How should an interviewer or lecturer react to a student who insists that she does not have a spatial problem, when all the empirical evidence available indicates that her three-dimensional visualization is one of the worst on record? Should staff demonstrators in practical anatomy tutorials pay more attention to left-handed students than to right-handers? Should hyper-tense students first be told that their scores on the geometric spatial battery can in no way lower their year's mark for anatomy, astronomy or engineering drawing, as the case may be, yet poorly motivated students be informed that their scores can affect their year marks? Should students leave a clinical interview satisfied that their knowledge of anatomy or astronomy has increased, or should they leave without any feedback? Should a grossly spatially handicapped student with a final, overall, year mark of 48% be given a compensatory pass instead of being required to repeat a failed year? Should the present investigation have been conducted at all? The questions are endless.

The illuminative evaluation model, the clinical interview approach and the case study method, however, all have their problems and weaknesses.

The first of these, Ruddock (1891:34) identifies as false coherence

in these terms:

In evaluation, as in other forms of enquiry, there is a danger of imposing a conceptual order upon an empirical chaos. If our evidence forces us to conclude that the field we are investigating is a confusion of conflicts and contradictions, how are we to transcend this confusion? Are we writing in bad faith if we attempt to give a coherent account of a process which is not coherent?

Millar, (1983:122) continues :

This problem is closely related to another, that of "objectivity". Case studies are criticised as being highly subjective forms of enquiry, and so they are. Two researchers studying the same "case" will inevitably differ in their selection of salient data, their series of framing questions, and even their grasp of major dynamics. Each will speak and think from a perspective that itself enters the case as an interpretive framework. What this means is that the case researcher's perspective itself requires exposure and problematising as part of the presentation of the study. Concealment, not subjectivity, is the crime. The case study addresses the critique of subjectivity by presenting findings, procedures, basic data, and its own frame of reference for public scrutiny and attack. It does not claim the status of "truth" or "last word"; it simply invites confrontation by a better analysis.

By using a combination of empirical and anthropological paradigms, the present investigation has probably come closer to this "truth" than would be the case had only a single research method been employed.

IMPLICATIONS AND RECOMMENDATIONS  
FOR FUTURE RESEARCH

The findings revealed by the current investigation have several implications for teaching and testing in spatially-orientated subjects at university level:

1. It is recommended that tests of spatial ability alone should never be used to admit or debar any student from commencing a course of study in anatomy, astronomy or engineering drawing.
2. If it is desired to diagnose the existence of spatial weaknesses in students for the purposes of special remedial instruction or prediction, it is recommended that specifically subject-based spatial tests be developed and validated in the particular discipline concerned (such as dentistry, radiology, architecture, crystallography, surveying, and so on); and that purely geometric spatial tests be used as subsidiary, confirmatory, diagnostic instruments only.
3. The optimum time for diagnosing serious spatial ineptitude during a course of study appears to vary from subject to subject. It is recommended that lecturers in different scientific disciplines determine this for themselves by trial and error. In anatomy at the University of Cape Town the optimum time for diagnosis appears to be after six months; in engineering drawing it is at the commencement of the course.

4. If the philosophy of a given university department is to provide special academic support for students with known disabilities, then there appears to be a strong case for extending this support to spatially inept students in anatomy, astronomy and engineering, as a matter of policy.
  
5. Finally, an implication of the findings of the present investigation concerns the psychological nature of spatial ability itself. Is it a skill to be developed, or is it an inherited capacity (like handedness or colour-blindness) which can be altered relatively little by experience?

Garry & Kingsley (1970) draw attention to this distinction when they write :

At any given moment each individual is possessed of certain abilities, that is, available and developed skills for performing acts of varying complexity, and certain capacities or potentials for development of future skills. Abilities are measured by achievement and performance tests; capacities are measured by intelligence and aptitude tests.

The results obtained in the current study appear to indicate that, for most science students, spatial visualization is a skill which can be acquired, though admittedly at widely differing rates. For a small minority of students (perhaps 2%-3%), however, spatial visualization appears to be a capacity for which they have an almost permanently low aptitude.

Many recommendations can be made for future research:

1. Since no previous investigations appear to have been conducted into spatial ineptitude as a significant and likely cause of under-achievement and failure in both anatomy and descriptive astronomy, there is an open field for research into the development of remedial teaching methods which will prove effective with students who manifest different types of spatial visualization problems. Possible starting points are described in Appendix H.
2. Recent work by Szabo, Dwyer & De Melo (1981) strongly supports the use of properly integrated visualization in the teaching-learning-testing process in human physiology. Whether the format of university theory examination papers in anatomy and descriptive astronomy should be changed to make them diagrammatic, rather than purely verbal, could be investigated.
3. The influence of home language and cultural background on spatial visualization ability in school and university science subjects offers a rich field for research, particularly in South Africa with its diversity of indigenous and immigrant population groups.

4. It is possible that some science students experience not only spatial visualization problems, but other visual difficulties as well, such as figure-ground problems, visual discrimination problems, visual sequencing problems, visual memory problems, visual constancy problems, visual closure problems, and so on. Whilst there appears to be evidence in students' sketches that this may be so, a new and much more rigorous and extensive investigation is required.
5. The current investigation could be repeated in other university science subjects such as surveying, physiotherapy, radiography, geology, electron microscopy and architecture, to name just a few.
6. Interactions of spatial ability with other factors such as attitude, home background, hobbies and interests, and so on, could be investigated in different disciplines.
7. The effectiveness of the diagnostic battery of geometric spatial exercises could be explored with different combinations of sub-tests in order to maximize its validity with different types of students.

8. The problem of the early identification of science students who are burdened with a virtually permanent and severe spatial difficulty is, perhaps, the most challenging and urgent area of research awaiting investigation.

Perhaps it is fitting to conclude with the following extract from the work of Chase & Simon (1973:278-279) which was discovered in connection with the case study of the unfortunate student chess champion (Chapter 4) who, surprisingly, appeared to remain almost permanently disabled in three dimensions, even after studying anatomy for two years:

Our specific aim in the experiments described in this paper has been to explain why it has been impossible to find non-chess tasks (such as general memory span) that measure chess skill, and to give some account of where that skill lies. Our answer is that chess skill depends in large part upon a vast, organized, long-term memory of specific information about chessboard patterns. Only chess-related tasks that tap this organization (such as the 5-second recall task) are sensitive to chess skill. Although there clearly must be a set of specific aptitudes (e.g. aptitudes for handling spatial relations) that together comprise a talent for chess, individual differences in such aptitudes are largely overshadowed by immense individual differences in chess experience. Hence, the overriding factor in chess skill is practice. The organization of the Master's elaborate repertoire of information takes thousands of hours to build up, and the same is true of any skilled task (e.g. football, music). That is why practice is the major independent variable in the acquisition of skill.

CHAPTER SIXSUMMARY, CONCLUSIONS AND RECOMMENDATIONS

In this final chapter, a brief resumé of the present investigation is presented with respect to its origin, its points of departure from earlier studies, its findings, how it reinforces and links up with the results obtained by other research workers, and the recommendations it makes for future research.

The present investigation differs from earlier studies in several ways.

Firstly, no previous investigations appear to have been conducted into the association between performance on spatial tests and academic achievement in anatomy and descriptive astronomy as individual subjects at university level. In particular, no use appears to have been made of tests of three-dimensional visualization and spatial orientation to diagnose, identify and predict individual students likely to under-achieve significantly and/or fail in anatomy and descriptive astronomy.

Secondly, no previous studies appear to have used a combination of both purely geometric spatial tests plus subject-based spatial tests (specially constructed within the context of an academic discipline itself) for diagnostic and predictive purposes.

Thirdly, no other research appears to have monitored comparatively the subject-based spatial and non-spatial performances of individual students, term by term, within a given spatially-orientated course of study, particularly with regard to both theory and practical examinations in the sciences.

More than 1000 students were involved in the present investigation and, of these, more than 600 were singled out for individual spatial monitoring. In all three disciplines (anatomy, descriptive astronomy and engineering drawing), it was found repeatedly that, over a four year period, student under-achievement is significantly related to performance scores on paper-and-pencil tests of spatial ability. It was also found that poor three-dimensional appreciation occurs at virtually all levels of achievement in anatomy and astronomy, but that the majority of spatially weak students demonstrate an increasing mastery of the three-dimensional aspects of their courses as their year of studies progresses. A small minority of students (perhaps 2% - 3%), however, appear to remain virtually permanently spatially disadvantaged, even at the end of two

years' exposure to a subject like anatomy which they repeat if they fail. This finding appears to support the related conclusion of Taylor (1980) who comments that less than 5% of first year engineering students at the University of the Witwatersrand are completely unable to form visual images of three-dimensional objects.

It was also found that the predictive validity of all paper-and-pencil tests of spatial ability decreases significantly with increasing time over a period of nine months or so, probably due to the spatial learning which occurs during an academic year. Brinkman (1966), Trotty (1977) and Moses (1977) also found that spatial ability is not innate, and is modifiable by instruction. In addition, the present study found that individual students achieve spatial competence at widely differing rates.

Many previous investigations have shown that there is a moderate, but significant relationship between spatial visualization ability and an understanding of scientific concepts in general. The present research has shown, however, that a subject-based spatial test, constructed by university teachers in a given scientific discipline, is a significantly better predictor of achievement within that discipline than a merely geometrically-based battery of spatial exercises. A subject-based spatial test is also a better diagnostic indicator of spatial ineptitude within a given scien-

tific discipline than a purely geometric spatial measure, although the two tend to correlate strongly, and are most effective when used in combination with each other.

One of the reasons for planning the present investigation to run over a period of at least four years was to try to establish the optimum month of the year for diagnosing and identifying students who would be likely to fail their year outright in a given academic subject as a result of severe three-dimensional visual impairment. Although the present investigation could only strongly infer (rather than prove) a direct causal relationship, it was established that that diagnostic spatial tests are best administered to engineering drawing students at the commencement of their course, to anatomy students at the University of Cape Town at mid-year, and to students of descriptive astronomy at any time during their studies due to the high pass rate which this popular astronomy course enjoys at this University.

In a broader context, the present investigation reinforces and links up with the many other earlier spatial studies which have established that the overall level of spatial conceptualization inherent in different branches of science varies from one scientific discipline to another, and even from one form of examination to another within a particular scientific subject. It also confirms

that the measurable effects vary, depending on the nature and type of tests selected for predictive or diagnostic purposes.

Of particular importance is the fact that the practical anatomy findings of the present investigation support the related conclusions of Just (1979) who found that the courses in his college dental curriculum which tended to require visualization abilities to a significant degree were those which were most concerned with the actual practice of dentistry, such as orthodontics, endodontics and operative dentistry. The findings with astronomy students in the present investigation support the conclusions of Kelsey (1980) and Sonntag (1981) that the spatial orientation ability of university science students is a factor to be considered when designing instructional techniques for classes learning basic astronomy. The findings with engineering drawing students are in harmony with those of Taylor (1980;1983) whose work identified spatial and other factors which affect student performance in a university engineering and design course.

On the other hand, the findings of the present investigation appear to contradict those of Blade & Watson (1955) who reported that prospective mechanical engineers were the most spatially competent students and prospective chemical engineers the least. The reverse finding, noted with 1983 students at the University of Cape Town,

is currently being verified with the 1984 class of engineering drawing students (N=280), and the findings will be separately published in due course.

The present investigation also points out the need to establish new norms for populations of students in different scientific disciplines as part of the process of validating diagnostic materials and remedial procedures. If commercially available tests of spatial ability are too easy for highly selected university medical or science students, lecturers in different disciplines may need to devise and validate their own, more difficult spatially-related subject-based diagnostic instruments.

The findings of the present investigation have several implications. University lecturers are cautioned against the use of spatial tests to exclude prospective students from entering a course of study in anatomy, astronomy or engineering drawing. To date there appears to be no way of distinguishing between prospective students who will achieve spatial skills rapidly, and those who will remain virtually permanently spatially handicapped through an entire course.

Secondly, it now seems almost inevitable that a good deal of future work on spatial performance in scientific subjects may well centre on the production, development and validation of discipline-

orientated measures of spatial ability, which appear to be more powerful predictive and diagnostic measures than merely geometric spatial tests. Geometric spatial tests, however, should still be retained, but it appears that their future role may become subsidiary and confirmatory.

The optimum points in time for administration of these tests, however, may well vary from one academic discipline to another. These have still to be established for a variety of scientific subjects such as surveying, physiotherapy, radiography, geology, architecture, crystallography, dentistry, organic chemistry, electron microscopy, meteorology, and so on.

Additional research is needed into the design of specialized teaching methods for students who acquire spatial visualization skills slowly (or not at all) in different areas of science. Also, decisions are required as to whether spatially disadvantaged students should be allowed an extended period of time during anatomy practical examinations, or whether the pass mark should be different for such students.

Another point which needs to be pursued is a recommended change in the marking procedure for batteries of spatial tests. It appears that a serious failure in even one geometric sub-test is usually

indicative of a spatial problem in anatomy and astronomy, even when the total (global) spatial battery score is high. This matter should be raised with the authorized distributors of standardized test materials such as Princeton's Educational Testing Service and the National Foundation for Educational Research in Britain, for possible ratification.

A further area for investigation is the extent to which university written examination papers in the sciences should contain illustrative drawings. A related problem, which arose during the investigation with anatomy students, concerns the fact that some students always pass their practical anatomy examinations well, yet underachieve consistently by approximately 15% throughout their year on unillustrated spatial MCQ anatomy examinations in relation to non-spatial MCQ anatomy examinations. This suggests that certain students may possess one type of visual skill, yet be deficient in another type.

Clearly, the present investigation needs to be repeated using students from different language and cultural groups, particularly in anatomy and astronomy, and especially in a country like South Africa.

Finally, the findings of this exploratory investigation need to be ratified in closer detail using more suitably validated tests, particularly where the identification of potential student failures is concerned. The commercially available NFER Spatial Test 3 which was employed, appears to be too easy for university science students as a whole. The officers at the Educational Testing Service also indicated that their spatial tests are unsuitable for the present investigation. Just (1979), whose doctoral dissertation investigated the spatial abilities of dental students, indicates that he is familiar with the ETS Kit of Factor-Referenced Cognitive Tests, but that he found it necessary to use his own battery of geometric spatial exercises. This author has followed suit, but Taylor (1980;1983) has used the suitably validated Blox Test successfully with university students of engineering drawing, and agrees with Deregowski who recommends the Space Relations Test. (Taylor, 1984: Personal Communication.) The findings described in the present investigation need to be validated by means of such carefully constructed tests before they can be fully accepted at face value.

---

LIST OF REFERENCES

- AUSUBEL, D.P. & ROBINSON, F.G. 1971  
School Learning : An Introduction to Educational Psychology.  
Holt, Rinehart & Winston.
- BAKER, D.R. 1981  
The Differences amongst Science and Humanities Males and Females. Unpublished paper presented at the annual meeting of the National Association for Research in Science Teaching - 54th, Grossinger's in the Catskills, Ellenville, New York, April 5-8.
- BAKER, S.R. & TALLEY, L.R. 1972  
The relationship of visualization skills to achievement in freshman chemistry. Journal of Chemical Education, vol. 11, no. 49, p775-776.
- BAKER, S.R. & TALLEY, L.R. 1974  
Visualization skills as a component of aptitude for chemistry - a construct validation study. Journal of Research in Science Teaching, vol. 11, no. 22, p95-97.
- BATTISTA, M.J., et al. 1982  
The importance of spatial visualization and cognitive development for geometry learning in preservice elementary teachers. Journal for Research in Mathematics Education, vol. 13, no. 5, p332-340.
- BERLOQUIN, P. 1980  
Geometric games. Unwin Paperbacks.
- BERMINGHAM, P.J. 1976  
Are ideas in three dimensions beyond you? Times Higher Education Supplement, November 5, p11.
- BERRY, G.A., HUGHES, R.L. & JACKSON, L.D. 1980  
Sex and handedness in simple and integrated task performance. Perceptual and Motor Skills, vol. 51, no. 3, part 1, p807-812.
- BESAG, F.P. & GREENE, J.B. 1981  
Unsafe at any score : standardized testing at a correctional facility. The Generator. The American Educational Research Association, vol. 11, no. 2, Spring, p29-53.
- BISHOP, J.E. 1978  
Developing students' spatial ability. The Science Teacher, vol. 45, no. 8, November, p.23.

- BISHOP, J.E. 1980  
The Development and Testing of a Participatory Planetarium Unit Emphasizing Projective Astronomy Concepts and Utilizing the Karplus Learning Cycle, Student Model Manipulation, and Student Drawing with Eighth Grade Students. Unpublished Ph.D., The University of Akron.
- BLADE, M.F. & WATSON, W.S. 1955  
Increases in spatial visualization test scores during engineering study. Psychological Monographs, vol. 69, no. 12, p1-13.
- BORICH, G.D. & BAUMAN, P.M. 1972  
Convergent and Discriminant Validation of the French and Guilford-Zimmerman Spatial Orientation and Spatial Visualization Factors. Paper presented at the American Psychological Association's 80th Annual Meeting, Honolulu, Hawaii, September 2.
- BRADLEY, C.F. 1981  
The Effects of Different Stimulation Modes on the Science Achievement of College Students with Varying Levels of Spatial Visualization Skill and Cognitive Development. Unpublished Ed.D., University of Georgia.
- BRENDZEL, S.D. 1981  
The Relationship between Proportional Reasoning and Visual Spatial Ability. Unpublished Ed.D., Rutgers University, The State University of New Jersey. Dissertation Abstracts International, vol. 42, p1574-A.
- BRINKMAN, E.H. 1966  
Programmed instruction as a technique for improving spatial visualization. Journal of Applied Psychology, vol. 50, p178-184.
- BROHN, D.M. & COWAN, J. 1977  
Teaching towards an improved understanding of structural behaviour. The Structural Engineer, vol. 55, no. 11, p496-515
- BRUNER, J.A., GOODNOW, J. & AUSTIN, G.A. 1956  
A Study of Thinking. New York : John Wiley and Sons.
- BURNETT, S.A., et al. 1981  
Spatial ability and handedness. Intelligence, vol. 6, no. 1, p57-68.
- BURNETT, S.A. & LANE, D.M. 1980  
Effects of academic instruction on spatial visualization. Intelligence, vol. 4, no. 3, p233-242.

## CAMBRIDGE CONFERENCE 1969

Report on Goals for the Correlation of Elementary Science and Mathematics. Houghton Mifflin.

## CAMPBELL, G. 1969

Programmed Learning in Mechanical Drawing : An Experiment to Determine the Effect of Presenting Programmed Units of Selected Elements of Orthographic Projection on the Ability of Pupils to Visualize Spatial Relations. New York University. Dissertation Abstracts International, vol. 30, p2354-A.

## CHASE, W.G. &amp; SIMON, H.A. 1973

The mind's eye in chess. Visual Information Processing. William G. Chase, ed. Academic Press, p215-281.

## COHEN, L. &amp; MANION, L. 1980

Research Methods in Education. Croon Helm Ltd.

## COONEY, T.J. &amp; DAVIS, E.J. 1964

Teaching concepts and generalizations in mathematics and science. Harvard Educational Review, vol. 34, Spring, p204-216.

## COOPER, L.A. &amp; SHEPARD, R.N. 1973

Chronometric studies of the rotation of mental images. Visual Information Processing. William G. Chase, ed. Academic Press, p75-176.

## COSFORD, Q. 1983

Training visual perception I. Clinic News. Cyclostyled bulletin of the Athlone School Clinic Association, Cape Town, September.

## CROSS, L.H., ROSS, F.K. &amp; GELLER, E.S. 1980

Using choice-weighted scoring of multiple-choice tests for determination of grades in college courses. Journal of Experimental Education, vol. 48, no. 4, p296-301.

## CROW, L.W. &amp; PIPER, M.K. 1983

A study of the perceptual orientation of community college students and their attitudes toward science as they relate to science achievement. Journal of Research in Science Teaching, vol. 20, no. 6, p537.

## DAVIES, T.N. 1976

The span of visual perception in engineering drawing. The Communicator of Scientific and Technical Information, England, April, p2-11. Cited in Kemp (1983), p 258.

## DAVIES, T.N. 1982

Visual perception associated with the graphic communication of information. Research Scheme R3128, Ministry of Overseas Development, Chester, England, January. Cited in Kemp (1983), p258.

- DAWSON, J.L.M. 1967  
Cultural and physiological influences upon spatial-perceptual processes in West Africa, part I. International Journal of Psychology, vol. 2, p115-128.
- DEREGOWSKI, J.B. 1977  
A Report on a Preliminary Investigation of the Difficulties Experienced by the First Year Students in Engineering Drawing. Department of Psychology, University of Rhodesia.
- DE WOLF, V.A. 1981  
High school mathematics preparation and sex differences in quantitative abilities. Psychology of Women Quarterly, vol. 5, no. 4, p555-567.
- DICKSON, M.H. 1974  
A Comparison of the Use of Models and Photographs in the Learning of Stereochemistry. Abstracts of Chemical Education Research, University of East Anglia, p3.
- DORSEY, W.W. 1978  
The Relationship between Visualization Skills and Learning Science Concepts of Freshman, Sophomore, Junior and Senior Premedical Students at Talledega College. Unpublished Ed.D., East Texas State University.
- DOYLE, J.J. 1980  
The order of attainment of eight projective groupings : an analysis of Piaget's spatial model. Journal of Research in Science Teaching, vol. 37, no. 1, p55-58.
- EASTMAN, P.M. & SALHAB, M. 1978  
The interaction of spatial visualization and general reasoning abilities with instructional treatment on absolute value equations. Journal for Research in Mathematics Education, vol. 9, no. 2, p152-154, March.
- EKSTROM, R., FRENCH, J. & HARMAN, H. 1976  
Manual for the Kit of Factor-Referenced Cognitive Tests. Educational Testing Service, Princeton, New Jersey.
- ELEY, M. 1977  
Spatial and verbal abilities in graduates in the natural sciences compared to graduates in other fields. The Australian Science Teachers' Journal, vol. 23, no. 3, p59-63.
- EL FARRA, 1982  
The Understanding of Stereochemistry Operations. Unpublished Ph.D., University of East Anglia.
- EL KOUSSY, A.A.H. 1935  
The Visual Perception of Space. Ph.D. Thesis in British Journal of Psychology, Monograph Supplement, Cambridge University Press.

- EL KOUSSY, A.A.H. 1955  
The Directions of Research in the Domain of Spatial Aptitudes.  
Edition of the Centre National de la Recherche Scientifique,  
Paris.
- ENIAIYEJU, P.A. 1981  
Understanding the Diagrammatic Representation of Rotation in  
Molecular Structures. Unpublished Ph.D., University of East  
Anglia.
- FLOY, P.J. 1975  
The importance of structure in learning chemistry. Science,  
vol. 188, p1268, June 27.
- FRENCH, J.W. 1951  
The description of aptitude and achievement tests in terms of  
rotated factors. Psychometric Monograph No. 5.
- GABEL, D. & SHERWOOD, R. 1980.  
The effect of student manipulation of molecular models on  
chemistry achievement according to Piagetian level. Journal of  
Research in Science Teaching, vol. 17, no. 1, p75-81.
- GAGNÉ, R.M. 1963a  
The learning requirement for enquiry. Journal for Research in  
Science Teaching, vol. 1, no. 2, p144-153.
- GAGNÉ, R.M. 1963b  
Learning and proficiency in mathematics. The Mathematics  
Teacher, vol. 56, December, p620-625.
- GAGNÉ, R.M. 1977  
The Conditions of Learning. Holt, Rinehart & Winston.
- GARRY, R. & KINGSLEY, H.L. 1970  
The Nature and Conditions of Learning. New Jersey : Prentice  
Hall, 3rd ed.
- GOODENOUGH, D.R., et al. 1977  
Cognitive styles in the development of medical careers. ETS  
Research Bulletin, p7-21. Quoted in Just (1979) p3;23-24.
- GUILFORD, J.P. 1956  
The structure of intellect. Psychological Bulletin, vol.53,  
p267-293.
- HANDLER, J.R. 1976  
An Exploratory Study of the Spatial Visualization Abilities  
and Problem Solving Processes Exhibited by High School  
Mathematics Students while Solving a Set of Geometry  
Problems. Unpublished Ed.D., The University of Tennessee.  
Dissertation Abstracts International, vol. 37, p7008-A.

- HARWELL, J.M. 1982  
How to Diagnose and Correct Learning Difficulties in the Classroom. New York : Parker.
- HEIDBREDER, E. 1945  
The attainment of concepts : terminology and methodology.  
Journal of General Psychology, vol. 35, October, p 191-193.
- HILL, D.M. 1970  
Report on two spatial abilities. Lab-Talk, Journal of the Science Teachers' Association of Victoria, vol. 14, no. 5, p27.
- HOLFORD, D.G. 1969  
A study of the Effectiveness of Stereoscopic Viewing in the Learning of Spatial Relationships in Structural Chemistry. Unpublished M.Sc., University of East Anglia.
- HUDSON, W. 1960  
Pictorial depth perception in sub-cultural groups in Africa.  
Journal of Social Psychology, vol. 52, p183-208.
- HYMAN, B.S. 1982  
The Role of Student Manipulation of Molecular Models and Spatial Visualization Ability on Achievement in College Level Organic Chemistry. Unpublished Ph.D., Columbia University Teachers College.
- JOHNSON, D.J. & MYKLEBUST, H.R. 1967  
Learning Disabilities : Educational Principles and Practices. New York : Grune & Statton.
- JOYCE, B. & WEIL, M. 1972  
Models of Teaching. Prentice-Hall.
- JUSOH, I.B. 1979  
Understanding the Pictorial Representation of Rotation in Molecular Structures. Abstracts of Chemical Education Research, University of East Anglia, p9-10.
- JUST, S.B. 1979  
Spatial Reasoning Ability as Related to Achievement in a Dental School Curriculum. Unpublished Ed.D., Rutgers University, The State University of New Jersey.
- KELSEY, L.T.G. 1980  
The Performance of College Astronomy Students on Two of Piaget's Projective Infralogical Grouping Tasks and their Relationship to Problems Dealing with Phases of the Moon. Unpublished PhD., The University of Iowa.
- KEMP, A. 1983  
Graphicacy and literacy in engineering education. The South African Mechanical Engineer, vol. 33, September, p256-260.

- KILBRIDE, P.L. & ROBBINS, M.C. 1968.  
Linear perspective, pictorial depth perception and education among the Baganda. Perceptual Motor Skills, vol. 27, p601-602.
- KLAUSMEIER, H.J., GHATALA, E.S. & FRAYER, D.A. 1974.  
Conceptual Learning and Development : A Cognitive View. New York : Academic.
- KOESLAG, J.H., MELZER, C.W. & SCHACH, S.R. 1979  
Inversions in true/false and in multiple choice questions - a new form of item analysis. Medical Education, vol. 13, p420-424.
- LEAN, G. & CLEMENTS, M.A. 1981  
Spatial ability, visual imagery and mathematical performance. Educational Studies in Mathematics, vol. 12, no. 3, August, p267-299.
- LOHMAN, D.F. 1979  
Individual Differences in Speed and Level in Spatial Ability. Unpublished Ph.D., Stanford University.
- MARSICANO, A.J. 1975  
The prediction of academic success in engineering technology. Engineering Education, vol. 66, p268-271.
- MARTIN, B.L. 1966.  
Spatial Visualization Abilities of Central Washington State College Prospective Elementary and Secondary Teachers of Mathematics. Unpublished Dissertation, Oregon State University.
- MCCLOSKEY, P. 1979  
The facilitation of spatial ability and problem solving in adolescent pupils through learning in design. Educational Review, vol. 31, no. 3, p259-267.
- MCCUSKEY, S.M. 1981  
Age Changes in Spatial and Object Orientation as Measured by Architectural Preference and EFT Visual Performance. Unpublished D.Arch., University of Michigan.
- MERCER, C.D. 1979  
Children and Adolescents with Learning Disabilities. Columbus, Ohio : Charles E. Merrill.
- MESSICK, S. 1980  
Test validity and the ethics of assessment. The American Psychologist, vol. 35, no. 11, p1012-1027.
- MICHAEL, W.B., GUILFORD, J.P., FRUCTER, B. & ZIMMERMAN, W.S. 1957  
The description of spatial-visualization abilities. Educational Psychological Measurement, vol. 17, p185-199.

- MILLAR, C.J. 1983  
Educational case studies : an introduction to a research perspective. Research Methods for Higher Degrees, Steinberg, M.B., ed. Faculty of Education, University of Cape Town, p115-125
- MORRIS, S.H. & UPTON, P.K. 1979  
A problem associated with the teaching of the physical sciences. The School Science Review, vol. 61, no. 214, p349-353
- MOSES, B.E. 1977  
The Nature of Spatial Ability and its Relationship to Mathematical Problem Solving. Unpublished Ph.D., University of Indiana.
- MUNDY, J.F. 1980  
Spatial Ability, Mathematics Achievement and Spatial Training in Male and Female Calculus Students. Unpublished Ph.D., University of New Hampshire. Dissertation Abstracts International, vol. 41, no. 11, May.
- NICHOLSON, J.R. & SEDDON, G.M. 1977  
The influence of secondary depth cues on the understanding of Nigerian schoolboys of spatial relationships in pictures. British Journal of Psychology, vol. 68, p327-333.
- NOVAK, J.D. 1980  
Learning theory applied to the biology classroom. The American Biology Teacher, vol. 42, no. 5, p280-285.
- O'BRIEN, W.H. 1980  
An Investigation of the Relationship between Spatial Achievement and the Achievement of High School Students in the Study of PSSC Physics. Boston University School of Education. Dissertation Abstracts International, vol. 40, p6222-A, June.
- OSIPOW, S.H. 1969  
Cognitive styles and educational-vocational preferences and selection. Journal of Counselling Psychology, vol. 16, p534-546.
- OYEDIJI, S.I. 1978  
An Investigation into the Self Instructional Remedial Method for Pictorial Depth Perception with the Nigerian Students. Abstracts of Chemical Education Research, University of East Anglia, p3.
- PARLETT, M. & HAMILTON, D. 1972  
Evaluation as Illumination : a new approach to the study of Innovatory Programs. Occasional Paper No 9. Centre for Research in the Educational Sciences, University of Edinburgh, October.

- PIAGET, J. 1953  
How children form mathematical concepts. Scientific American,  
vol. 189, November, p74-79.
- PIAGET, J. & INHELDER, B. 1956  
The Child's Conception of Space. London : Routledge and Kegan  
Paul.
- POOLE, C. & STANLEY, G. 1972  
A factorial and predictive study of spatial abilities.  
Australian Journal of Psychology, vol. 24, no. 3, p317-320.
- PORTER, C.F. 1982  
The Effects of Two-Dimensional, Three-Dimensional, and a  
combination of Two- and Three-Dimensional Instructional  
Strategies on the Achievement of High School Biology Students  
with Varying Levels of Spatial Visualization Ability,  
Cognitive Development, and Gender. Unpublished Ed.D.,  
University of Georgia.
- QUINLAN, D.M. & BLATT, S.J. 1972  
Field articulation and performance under stress : Differential  
predictions in surgical and psychiatric nursing training.  
Journal of Consulting and Clinical Psychology, vol. 39, p517.
- REMSTTAD, R.C. 1969  
Optimizing the Response to a Concept Test through Sequential  
Classroom Experimentation. Technical Report No 85. Wisconsin  
Research and Development Centre for Cognitive Learning,  
Madison, p25-50. Mentioned in Dorsey (1978), p20.
- ROE, A. 1953  
A psychological study of eminent psychologists and  
anthropologists, and the comparison with biological and  
physical scientists. Psychological Monographs, vol. 67, p1-  
54. See also Dorsey (1978), p27;39.
- ROLFE, J.M. 1980  
Correlation between Spatial Perception Aptitude Tests and the  
Brohn-Cowan Tests of Understanding of Structural Behaviour.  
Unpublished paper presented at the Workshop on Spatial  
Perception. University of the Witwatersrand, Johannesburg,  
April 8-9.
- ROSS, A.R. 1976  
The Remedial Treatment of Problems of Depth Perception in  
Diagrams. Unpublished M.Sc., University of East Anglia.
- ROTHMAN, A.I. & KERENYI, N. 1980  
The assessment of an examination in pathology consisting of  
multiple-choice, practical and short essay questions. Medical  
Education, vol. 14, p341-344.

- ROVET, J.F. 1974  
Can Spatial Skills be Acquired Via Film? An Analysis of the Cognitive Consequences of Visual Media. Unpublished Ph.D., University of Toronto. Dissertation Abstracts International, vol. 37, p7649-A.
- RUDDOCK, R. 1981  
Evaluation : A Consideration of Principles and Methods. Manchester Monographs. University of Manchester.
- SCHATZ, D. 1978  
Student reasoning ability and astronomy teaching. Newsletter of the International Astronomical Union : Commission 46 - Teaching of Astronomy, vol. 3, p4-8.
- SCHATZ, D. & LAWSON, A.E. 1976  
Effective astronomy teaching : intellectual development and its implications. Mercury, vol. 5, no. 4, July/August, p6-13.
- SCHONBERGER, A.K. 1976  
The Interrelationships of Sex, Visual Spatial Abilities and Mathematical Problem Solving Ability in Grade Seven. Unpublished Ph.D. The University of Wisconsin-Madison. Dissertation Abstracts International, vol. 37, p3536-A.
- SEDDON, G.M. & TARIQ, R.H. 1982  
The visualization of spatial transformations in diagrams of molecular structures. The European Journal of Science Education, vol. 4, no. 4, p409-420.
- SEEBER, F.P. 1981  
A Study of the Effect upon Physics Achievement of the Use of Spatial Reasoning in the Teaching of Introductory Physics. Unpublished Ed.D., Rutgers University, The State University of New Jersey (New Brunswick).
- SHARO, E.J. 1962  
Physics, Mathematics and Visual Spatial Relations : an Investigation of Aptitude. Unpublished Ph.D. dissertation, New York University, p1-35.
- SHUBBER, K.E. 1982  
Understanding Rotation in Molecular Diagrams. Unpublished M.Sc., University of East Anglia.
- SIEMANKOWSKI, F.T. & MacKNIGHT, F.C. 1971  
Spatial cognition : success prognostication in college science courses. Journal of College Science Teaching, vol. 1, no. 1, p56-59.
- SMAIL, B. 1983  
Spatial visualization skills and technical crafts education. Educational Research, Journal of the NFER, vol. 25, no. 3, p230-231.

- SMITH, I.M. 1964  
Spatial Ability : Its Educational and Social Significance.  
University of London Press.
- SMOKE, K. 1942  
An objective study of concept formation. Psychometrics Monographs, vol. 42, pl-5. Cited in Dorsey (1978), pl7-18.
- SONNTAG, M.A. 1981  
An Experimental Study of Teaching Method, Spatial Orientation Ability and Achievement in Selected Topics of Positional Astronomy. Unpublished Ph.D., University of Colorado at Boulder.
- SPEARMAN, C. 1923  
The Nature of Intelligence and the Principles of Cognition.  
New York : MacMillan.
- STALLINGS, W.M. 1968  
The effect of teaching descriptive geometry in General Engineering 103 on spatial relations test scores. Report No. RR-280, Office of Instructional Resources, Illinois University, September 26.
- ST. JOHN, P.A.W. 1978  
Effects of a Remedial Art Programme for Visuo-Spatial-Motor Skills on Drawings by Neurologically Impaired Children : A Multi-Case Study. Unpublished Ed.D., Columbia University Teachers College.
- STONES, E. 1979  
Psychopedagogy : Psychological Theory and the Practice of Teaching. Methuen & Co. Ltd.
- STUIT, D.B. & LAPP, C.J. 1941  
Some factors in physics achievement at the college level. Journal of Experimental Education, vol. 9, p251-253.
- SZABO, M: DWYER, F.M. & DE MELO, H. 1981  
Visual testing - visual literacy's second dimension. Educational Communication and Technology - Journal of Theory, Research and Development, vol. 29, no. 3, pl77-187.
- TALLEY, L.H. 1973  
The use of three-dimensional visualization as a moderator in the higher cognitive learning of concepts in college level chemistry. Journal of Research in Science Teaching, vol. 10, no. 3, p263-269.
- TARIO, R.H. 1982  
Problems in Teaching Stereochemistry and the Second Law of Thermodynamics. Unpublished PhD., The University of East Anglia.

- TAYLOR, J.M. 1980  
Factors Associated with Success in an Engineering Drawing and Design Course. Special Report No 314, National Institute for Personnel Research, Council for Scientific and Industrial Research, Johannesburg, South Africa.
- TAYLOR, J.M. 1983  
Factors Affecting Results of an Engineering Drawing and Design Course ; Part Two. Unpublished paper, National Institute for Personnel Research, Council for Scientific and Industrial Research, Johannesburg.
- THURSTONE, L.L. 1938a  
Primary mental abilities. Psychometric Monograph, no. 1.
- THURSTONE, L.L. 1938b  
Primary Mental Abilities. Illinois : University of Chicago Press.
- THURSTONE, L.L. 1950  
Some primary abilities in thinking. University of Chicago Psychometric Laboratory Report, no. 59.
- TOMKINS, S.S. & MINER, J.B. 1959  
The Tomkins-Horn Picture Arrangement Test. New York : Springer.
- TROTTY, S.A.G. 1977  
An Examination of the Relationship of Imagery Instruction to the Spatial Visualization and Manipulation, Art Information and Attitude, and Qualitative Visual Art Performance of Elementary Education Majors. Unpublished Ph.D., Purdue University. Dissertation Abstracts International, p5807-A.
- VINACKE, W.E. 1951  
The investigation of concept formation. Psychology Bulletin, vol. 48, January, p1-31.
- VAN ARSDEL, J. 1983  
Children's drawings as an assessment of cognitive style. Educational Research. Journal of the NFER, vol. 25, no. 1, February, p74-75.
- VOELKER, A.M. & SORENSON, J.J. 1970  
Items for Measuring the Level of Attainment of Selected Classificatory Science Concepts by Intermediate Grade Children. Working Paper No 58, Wisconsin Research and Development Centre for Cognitive Learning, Madison.

- WATTANAWAHA, N. & CLEMENTS, M.A. 1982  
Qualitative aspects of sex-related differences in performances on pencil-and-paper spatial questions, grades 7-9, Journal of Educational Psychology, vol. 74, no. 6, p878-887.
- WEIGL, E. 1941  
On the psychology of the so-called process of abstraction. Journal of Abnormal and Social Psychology, vol. 36, January, p3-33.
- WILLIAMS, J.D. 1979  
Stages of Piagetian Tasks and Spatial Relations in University Students. Paper presented at the Ninth Annual Conference on Piagetian Theory and its Implications for the Helping Professions. Los Angeles, California, February 2-3.
- WINN, W. 1982  
Visualization in learning and instruction : a cognitive approach. Educational Communication and Technology - Journal of Theory, Research and Development, vol. 30, no. 1, p 3-25.
- WITKIN, H.A. 1977  
Field dependent and field independent cognitive styles. Review of Educational Research, vol. 47, p1-64.
- WITKIN, H.A.; MOORE, C.A.; OLTMAN, P.K.; GOODENOUGH, D.R.; FRIEDMAN, F.; OWEN, D.R. & RASKIN, E. 1977  
Role of the field dependent and field independent cognitive styles in academic evolution : A longitudinal study. Journal of Educational Psychology, vol. 69, no. 3, p197-211.
- WOLFLE, D. 1940  
Factor analysis to 1940. Psychometric Monograph, no. 3.
- WORMACK, L. 1980  
Restructuring ability among premedical and pre dental minority students. Journal of Research in Science Teaching, vol. 17, no. 6, p577-582.
- WORSNOP, J.G. 1975  
An Investigation into the Possible Remedial Effect of Stereoscopic Projection in the Field of Pictorial Depth Perception. Abstracts of Chemical Education Research, University of East Anglia, p4.
- WRIGHT, G.S. 1982  
Sex Differences, Spatial Visualization Ability and the Effects of Induced and Imposed Imagery on Problem Solving Performance. Unpublished Ph.D., University of Southern California. Dissertation Abstracts International, vol. 43, no. 1 July, p115-A.

ZIMMERMAN, W.S. 1954a

The influence of item complexity upon the factor composition of a spatial visualization test. Educational Psychological Measurement, vol. 14, no. 1, p106-119.

ZIMMERMAN, W.S. 1954b

Hypotheses concerning the nature of spatial factors. Educational Psychological Measurement, vol. 14, no. 2, p396-400.

APPENDIX A

EXAMPLES OF SKETCHES MADE BY UNIVERSITY ANATOMY  
AND ASTRONOMY STUDENTS WHICH ARE INDICATIVE OF  
SERIOUS PERCEPTUAL SPATIAL PROBLEMS.

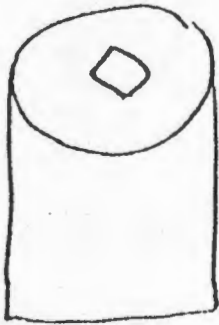

CYLINDER WITH SQUARE HOLE

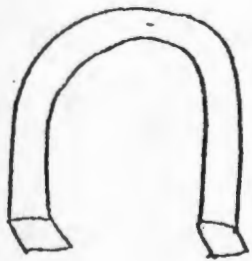
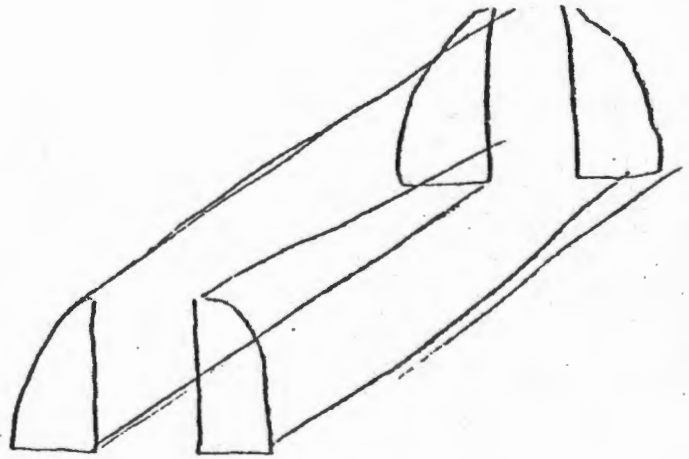

HORSESHOE.

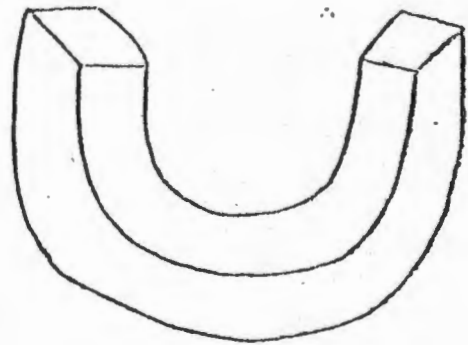

SPADE

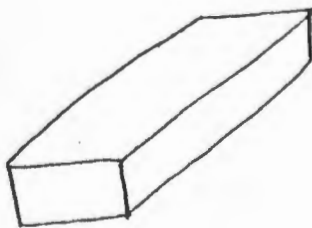

MATCHBOX

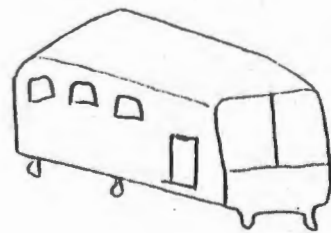

BUS

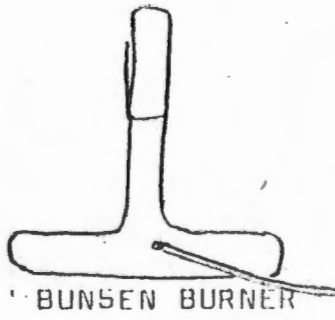

BUNSEN BURNER



BUNSEN BURNER



SHOE

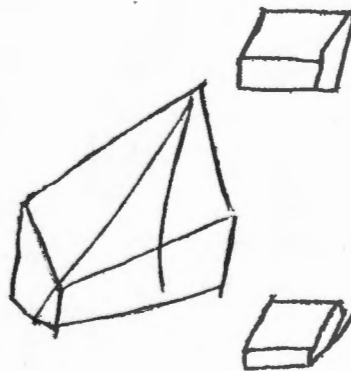

MATCHBOX

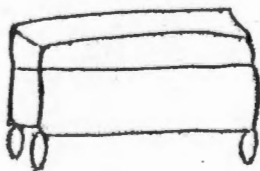

BUS

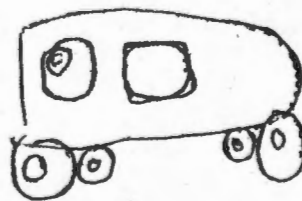

BUS

APPENDIX B

EDGAR STONES' SCHEDULE FOR  
THE TEACHING OF CONCEPTS

APPENDIX B

Stones (1979) sets out the following schedule for the teaching of concepts:

A. PRE-ACTIVE

- 1) Make a task analysis of the teaching objectives to identify the key concepts involved, the subordinate concepts, specific examples, methods of presentation, pupils' activities and modes of evaluation.
- 2) Ascertain pupils' prior knowledge. If this is not possible plan for diagnosis at the interactive stage.

B. INTERACTIVE

- 3) Give a preliminary idea of the nature of the new learning.
- 4) Explain terms to be used in labelling the new concepts and their attributes and call to mind existing concepts relevant to the new learning.
- 5) Provide initially a series of simplified exemplars with few attributes to facilitate identification of the criterial attributes.
- 6) Increase the salience of the criterial attributes to enable pupils to discriminate readily between criterial and non-criterial attributes.
- 7) Provide a series of exemplars sequenced to provide a complete range of criterial attributes as economically as possible.
- 8) Provide non-exemplars in counterposition to exemplars to enhance discrimination between criterial and non-criterial attributes.
- 9) Provide new exemplars and non-exemplars and ask the pupils to identify the exemplars. Provide feedback for each discrimination.
- 10) Encourage the pupils to use their own language in explaining the nature of the concepts.
- 11) Provide suitable cueing throughout to ensure that pupils gradually become independent in their ability to identify novel exemplars of the concepts.

C. EVALUATIVE (This process is naturally much the same procedure as would be applied in diagnosing prior level of ability.)

- 12) Present novel exemplars of the concepts for the pupils to identify and/or discriminate from non-exemplars.

APPENDIX C

A CONCISE HISTORICAL ACCOUNT OF  
ATTEMPTS TO SUB-DIVIDE, CLASSIFY  
AND AMALGAMATE THE SUB-DIVISIONS  
OF THE SPATIAL FACTOR BETWEEN  
1948 and 1964.

## APPENDIX C

A CONCISE HISTORICAL ACCOUNT OF ATTEMPTS TO SUB-DIVIDE, CLASSIFY  
AND AMALGAMATE THE SUB-DIVISIONS OF THE SPATIAL FACTOR BETWEEN  
1948 AND 1964

By 1955 El Koussy had not only attempted to demonstrate empirically that the spatial factor is a sub-division of a broader factor, he had also shown how the spatial factor, during the course of time, had been sub-divided into five components :  $S_1$ ,  $S_2$ ,  $S_3$ , Visualization  $V_z$  and Mental Manipulation  $M_a$ . These components were explained as follows :

- (i)  $S_1$  is "the ability to recognize the identity of an object when it is seen from different angles... the ability to visualize an object in rigid configuration when it is moved into different positions" (Thurstone, 1950; quoted in Michael, et al, 1957 : 188);  
"an ability to make discriminations as to the direction of motion (appreciating spatial directions from the body), such as up and down, left and right, and in and out"  
(Guilford, 1948; quoted in Smith, 1964 : 85).  
The flags test is a good example of sub-factor  $S_1$ .
- (ii)  $S_2$  is "the ability to imagine the movement or internal displacement among the parts of a configuration" (Thurstone, 1950; quoted in Michael, et al., 1957: 188).  
Tests of mechanical movement and surface development are suitable examples of sub-factor  $S_2$ .
- (iii)  $S_3$  is "the ability to think about those spatial relations in which the body orientation of the observer is an essential part of the problem." (Thurstone, 1950; quoted in Michael, et al., 1957 : 188).
- (iv)  $V_z$ , Visualization, requires the mental manipulation of visual objects involving a specified sequence of movements. The object appears within a more or

less/.....

less complex stimulus pattern. The individual finds it necessary mentally to rotate, turn, twist or invert one or more objects, or parts of a configuration according to relatively explicit directions as to what the nature and order of the manipulations should be. The examinee is required to recognize the new position, location, or changed appearance of objects that have been moved or modified, within a more or less complex configuration. In some instances he is required to present a record of his solution by drawing appropriate responses (Michael, Guilford, Fruchter & Zimmerman, 1957). It involves a manipulative visual-imagery process (Humphries, 1947). The punched holes test, the form board test, mechanical comprehension, paper folding, surface development, and descriptions of painted blocks or cubes are examples of tests of  $V_z$ .

- (v)  $M_a$  : Mental manipulation appears to overlap the spatial domain. Salam - referred to by El Koussy (1955)-devised thirteen tests involving visualization and manipulation separately or simultaneously and was able to separate clearly the two factors, visualization,  $V_z$ , and mental manipulation,  $M_a$ . Salam found that this wide factor occurred not only in three-dimensional spatial material, but also in numerical and verbal abilities.

Unfortunately these five components  $S_1$ ,  $S_2$ ,  $S_3$ ,  $V_z$  and  $M_a$  are neither exclusive nor independent of each other, and at least two are virtually identical, as we will see.

French (1951) attempted to summarize all of the investigations since 1928 and he sub-divided spatial ability into only three factors which he named :-

- (vi) S(Space) : The ability to perceive spatial patterns accurately and to compare them with each other. This appeared to enter into the perception of both two-dimensional and three-dimensional space (Wolfe, 1940). This factor appeared prominently in tests requiring the subject to react to spatial relations, to read plans or blueprints, or to tell quickly whether two drawings represent the same or opposite sides of asymmetrical figures such as flags.
- (vii) SO (Spatial Orientation) which seemed to involve a person's ability to remain unconfused by the varying orientations in which a spatial pattern may be presented.
- (viii) (S)V<sub>z</sub> (Spatial Vizualiation) : The ability to comprehend imaginary movement in three-dimensional space, or the ability to manipulate objects in imagination. (This factor appears to be very similar to (iv) V<sub>z</sub>.)

According to Smith (1964 : 90), however, these last three factors are not clearly separable.

Thurstone (1950) proposed another component of the spatial factor in addition to S<sub>1</sub>, S<sub>2</sub> and S<sub>3</sub>:-

- (ix) K(Kinaesthetic imagery), a highly tentative factor found only in the Hands test and the Bolts test, and thought to represent merely a left-right discrimination with respect to the location of the human body.

Guilford and Lacy (1947) proposed that spatial ability comprised not only Spatial Relations S<sub>1</sub>, S<sub>2</sub> and S<sub>3</sub> and the Visualization factor, V<sub>z</sub>, but also :-

- (x) L, a length estimation factor, and
- (xi) P, a perceptual speed factor.

In 1957/.....

In 1957 Michael, Guilford, Fruchter and Zimmerman, while attempting to synthesize the work of French, Thurstone, et al., proposed that spatial ability comprises only three factors with a certain amount of overlap or correlation amongst them. The three components are  $V_z$ , Visualization; K, kinaesthetic imagery, and :-

- (xii) SR-0, Spatial Relations and Orientation, which was thought to enter into the ability to comprehend the nature of the arrangement of elements within a visual stimulus pattern, primarily with respect to the examinee's body as the frame of reference. In a typical test of this factor, when the entire configuration (or a principal component of it) is moved into a different position, the objects within the pattern hold essentially the same relationships to one another.

According to Michael, et al. (1957), SR-0 could be regarded as a composite of French's Space (S) and Spatial Orientation (SO), and also forms more or less a composite of Thurstone's  $S_1$  and  $S_3$  factors.

They also stated that  $V_z$ , Visualization, is essentially the same as Thurstone's  $S_2$ -factor, a conclusion fully supported by Smith (1964 : 90).

Thus factors (i)  $S_1$ , (ii)  $S_2$ , (iii)  $S_3$ , (vi) S and (vii) SO described above may be deleted and replaced by just (iv)  $V_z$  and (xii) SR-0.

Hence the twelve possible, historical factors named so far were reduced to a mere six, as follows :-

- |         |   |
|---------|---|
|         | (iv) $V_z$ , Visualization                    |
|         | (v) $M_a$ , Mental manipulation               |
|         | (ix) K, Kinaesthetic imagery (tentative)      |
| Minor   | (x) L, Length estimation                      |
| factors | (xi) P, Perceptual speed, and                 |
|         | (xii) SR-0, Spatial Relations and Orientation |

Furthermore/.....

Furthermore, Smith (1964 : 90) points out that tests of Spatial Visualization and Spatial Orientation have correlated from 0.50 to 0.75 with different groups of students, and since 0.75 is not far short of the reliability coefficient for some of these tests (e.g. 0.89), there would seem to be a strong case for considering (iv)  $V_z$  and (xii) SR-0 to be sub-factors of a single, broad, spatial factor rather than as separate factors. He adds :-

In spite of the numerous studies carried out with large samples of testees and the many discussions, seminars and symposia conducted on the problem since the early investigations by Kelley and Thurstone, it cannot be said that clear-cut distinctions have been established .... between the different spatial factors and especially between SR-0 and  $V_z$ . (Page 95)

To reduce the above list of five or six possible factors even further, Zimmerman (1954) showed with his Visualization of Manoeuvres test using a model aircraft with aviation students, that the three factors (xi) P, Perceptual Speed, (vi) S, Space and (iv)  $V_z$ , Visualization measured merely the degree of difficulty or complexity of the task tested. The simplest form of the test (an aircraft turn or bank) had by far the highest loading in P, Perceptual Speed; the moderately difficult form (two movements of the aircraft) was the best measure of the Space factor, S; and the most difficult form (to predict the orientation of the model aircraft after three manoeuvres) proved to be the best measure of  $V_z$ .

Zimmerman also concluded that Thurstone's  $S_1$  and  $S_2$  could likewise be simply distinguished on the basis of the degree of difficulty and complexity involved, so were not different factors.

In an/.....

In an attempt to define the critical attribute of the Visualization sub-factor  $V_z$  Smith (1964 : 96) proposed that the  $V_z$ - loading of a test "depends on the degree to which it involves the perception, retention, and recognition (or reproduction) of a figure or pattern in its correct proportions. Success on this item must depend critically on an ability to retain and recognize (or reproduce) a configuration as an organized whole". The relations between the parts of the configuration must be grasped implicitly.

Although Smith (1964) argued that there would seem to be a strong case for considering both  $V_z$  and SR-0 to be sub-factors of a single, broad, spatial factor rather than as separate factors, he does report that the best  $V_z$  tests for measuring aptitude for engineering are three-dimensional tests, and among two dimensional tests the best are those which depend most on visualization.

APPENDIX D

DEFINITIONS OF SEVEN FACTORS

IN THE E T S KIT OF

FACTOR-REFERENCED

COGNITIVE TESTS.

REFERENCED COGNITIVE TESTS

Flexibility of Closure - the ability to hold a given visual percept or configuration in mind so as to disembed it from other well defined perceptual material.

Although not supported by the manual, Witkin, et al. (1962) concluded that field dependence/independence and flexibility of closure are the same dimension. The Hidden Figures Test which was developed by Jackson, et al. (1964) as a shortened version of the EFT, loads on this factor.

Speed of Closure - the ability to unite an apparently disparate perceptual field into a single concept.

Tests of this type require the subject to mentally reorganize and unify an incomplete visual stimulus.

Visual Memory - The ability to remember the configuration, location, and orientation of figural material.

This factor relates to the ability to store visual material in memory while eliminating irrelevant material.

Perceptual Speed - Speed in comparing figures or symbols, scanning to find figures or symbols, or carrying out other very simple tasks involving visual perception.

This factor is related to flexibility of closure, but does not require the subject to disembed the figures or symbols.

Spatial Orientation - The ability to perceive spatial patterns or to maintain orientation with respect to objects in space.

Tests which load on this factor usually involve the ability to mentally rotate an object in two or three dimensional space.

Spatial Scanning - Speed in exploring visually a wide or complicated spatial field.

Tests of maze tracing ability load on this factor.

Visualization - The ability to manipulate or transform the image of spatial patterns into other arrangements.

APPENDIX E

CORRESPONDENCE WITH THE  
EDUCATIONAL TESTING SERVICE

(ETS)

## UNIVERSITY OF CAPE TOWN

(WITH WHICH IS INCORPORATED THE SOUTH AFRICAN COLLEGE)

FACULTY  
OF  
EDUCATION

TELEPHONE 69-8531

RONDEBOSCH,  
7700  
South Africa.  
80. 12. 30.

The Information Division  
Educational Testing Service  
Princeton  
New Jersey 08540  
U.S.A.

Dear Sir,

I would be grateful if you could provide me with details as to the nature, availability and cost of tests of spatial reasoning ability suitable for use with secondary- and tertiary-level students, particularly paper and pencil tests of ability to see and reason in three dimensions with reference to such subjects as anatomy, astronomy, architecture, engineering, chemistry, geography, crystallography, etc.

Could you include in your reply details as to approximate airmail and surface mail costs, together with details of the conditions under which the tests may be used? Please could you also supply details of further tests which may be relevant such as Thurstone's Hidden Patterns Test, Thurston's Paper Folding Test, the Card Rotations Test and the NFER Spatial Tests?

Yours faithfully  
*K. Rochford*  
K. Rochford  
(Lecturer)

EDUCATIONAL TESTING SERVICE



PRINCETON, N.J. 08541

609-921-9000  
CABLE-EDUCTESTSVC

January 28, 1981

K. Rochford, Lecturer  
University of Cape Town  
Rondebosch  
7700  
SOUTH AFRICA

Dear Madam/Sir:

Thank you for contacting Educational Testing Service for information about purchasing tests that we publish. We do not, however, produce any tests that would be suitable for the purposes that you described.

We have enclosed a pamphlet of information on bibliographies that we have compiled, which list tests of other publishers that may be of use to you. On these bibliographies, each test is described and publishers' addresses are provided so that you may contact them for sample copies.

We hope that you find this information helpful. Please feel free to contact us at any time.

Sincerely,

Alicia Dodd  
Assistant  
Test Collection

PS. Thurstone's Hidden Patterns and Paper Folding Tests are available from:  
Education Industry Service, 1225 East 60th. St., Chicago, IL 60637.  
The NFER Spatial Tests are available from NFER Publishing Company, Ltd.,  
Darville House, 2 Oxford Rd. East, Windsor, Berkshire SL4 1DF England

APPENDIX F

THE DIPT CLASSIFICATION SYSTEM

FOR SPATIAL TASKS

### The DIPT Classification System for Spatial Tasks

#### Dimensionality (D)

- 1: A question requiring 1-dimensional thought.
- 2: A question requiring 2-dimensional thought, but not 3-dimensional thought.
- 3: A question requiring 3-dimensional thought.

#### Internalization (I)

- 0: The question can be done at the perceptual level. There is either no need for a visual image to be constructed, or the only visual image needed is a duplicate of a given stimulus or an image corresponding to a simple translation of all or part of the stimulus.
- 1: There is a need for a visual image to be constructed, but in order to do the question there is no need to transform the image in the mind.
- 2: There is not only a need for a visual image but in order to do the task this image must be operated upon (transformed) in the mind.

#### Presentation (P)

- 0: The expected answer form does not require a final visual image to be described, identified, or drawn on paper.
- 1: The answer is a picture which has to be identified from a number of different pictures which are presented in diagrammatic form, or are described by words or actions. The picture to be identified must correspond to the final visual image associated with the task.
- 2: The answer requires that the final visual image be represented by a drawing, or be described in words or by hand or other movements.

#### Thought process (T)

- 0: The task specifies the mental operation which needs to be carried out.
- 1: The task does not specify the mental operation but enough information is given for this to be determined.

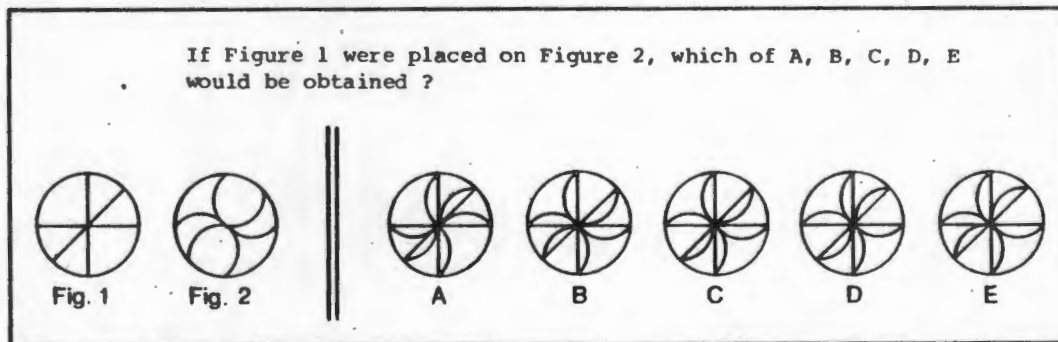

Figure 2. A question with DIPT classification (2,1,1,0). (DIPT = Dimensionality, Internalization, Presentation, Thought Process.)

APPENDIX G

PREVIOUS STUDIES ON THE RELATIONSHIP

BETWEEN SPATIAL VISUALIZATION

IN PHYSICS, CHEMISTRY

BIOLOGY AND MATHEMATICS

APPENDIX GPREVIOUS STUDIES ON THE RELATIONSHIP BETWEEN SPATIAL VISUALIZATION  
ABILITY AND ACADEMIC SUCCESS IN PHYSICS, CHEMISTRY, BIOLOGY AND  
MATHEMATICSIN CHEMISTRY AND PHYSICS

The association between spatial visualization, competence and success in the physical sciences has been demonstrated in many different studies. Siemankowski & MacKnight (1971), for example, compared the three-dimensional conceptual abilities in science majors, non-science majors, and students majoring in different areas of science at the State University College at Buffalo, New York. The selected students were given two spatial tests, the Survey of Space Relations Ability (SSRA) and Survey of Object Visualization (SOV). The scores on the two tests were combined and the means calculated. The following ranks were obtained :

Non-science majors            (lowest scores)  
Chemistry majors  
Biology majors  
Geology majors  
Physical Science majors    (highest scores)

Eley (1977) confirmed this pattern of results with post-graduate teachers-in-training in Tasmania.

Talley (1973) proposed that spatial visualization skills are associated with problem-solving in chemistry. He demonstrated that the appropriate use of small, individual, molecular model kits enhanced performance on a test of spatial visualization, and on questions at cognitive levels above recall on Bloom's taxonomy, such as critical reasoning.

Baker & Talley (1974) found an average correlation of 0.43 between scores on a test of spatial visualization and scores on problem-solving items with 40 first year college students and 12 senior chemistry students at West Liberty State College in Virginia. They used two of Thurstone's tests : the Surface Development Test and the Paper Folding Test. These investigators concluded that visualization skills may have served as a catalyst in enhancing the ability of students to function more effectively in undergraduate chemistry. (Apparently Baker and Talley assumed that visualization skills were independent of academic ability, at least for the purpose of their investigation.)

These findings complement those of Sharo (1962) whose subjects were 60 pupils between the ages of 15 and 19, and of high scholastic achievement, at Stuyvesant High School in New York. He reported that the highest correlations occurred between spatial visualization skills and performances on physics tests, followed by correlations between visualization skills and performances on mathematics tests, and that there was negligible correlation between visualization skills and English test scores.

Working with Nigerian chemistry pupils, Nicholson & Seddon (1977) showed that, if diagrams are depth-cued correctly, they are as effective as photographs in assisting schoolboys to perceive three-dimensionally.

In an investigation into difficulties associated with chemistry pupils' ability to visualize rotation in molecular diagrams, Eniaiyaju (1981) administered two diagnostic tests to 149 third and fourth form students in England and to 701 fourth and fifth form students in Nigeria. The results of the diagnoses indicated that a significant proportion of English and Nigerian pupils could not visualize rotation in molecular diagrams, particularly around the vertical and horizontal axes.

Following up the work of Baker & Talley, Hyman (1982) divided into three groups a population of students in an organic chemistry course at an academically-orientated liberal arts college. He found that requiring students merely to observe lecture-demonstrations with molecular models was equally as effective as ensuring that the students actually manipulated the models themselves, in increasing achievement over those who received neither demonstrations nor manipulations. Hyman concluded that a well-organized lecture demonstration with molecular models is a satisfactory means of helping students to acquire a better understanding of chemical spatial concepts. He also found that achievement on certain examination questions was significantly related to initial spatial visualization ability.

A great deal of research in chemical education at the University of East Anglia is currently concerned with problems encountered by students in understanding three-dimensional spatial relationships in diagrams, and the visualization of movements of three-dimensional molecular structures, for example, rotation, reflection or translation, or a combination of these movements.

In an investigation into pupils' understanding of operations in stereochemistry El Farra (1982) identified deficiencies in

visualizing the pictorial depth in diagrams drawn to represent three-dimensional structures. Two tests, the Framework Test (based upon crystal structures) and the Cues Test (based upon molecular structures), were given to 598 Kuwaiti secondary school pupils, aged 15-16 years, to assess their understanding of four depth cues, that is, overlap, foreshortening of lines, distortion of angles and relative size. 92 of these pupils were identified as spatially deficient. In addition, the problem of understanding reflection, rotation and inversion in diagrams was investigated. Four tests, that is, the Mirror Image, the Rotation, the Inversion and the Molecular Diagram Tests were administered to 402 Kuwaiti subjects randomly selected from secondary school, university and science teacher levels. The results of ANOVA indicated that years of schooling significantly affected performance on the tests. Also, it was concluded that there is a hierarchical connection between tasks associated with visualizing rotation and inversion and those associated with visualizing depth in a static structure diagram.

Finally Tariq (1982) has recorded the results of his diagnostic investigations into the simple operations of reflection, rotation and inversion in diagrams of molecular structures. A test was constructed to assess the average level of performance in absolute terms on these operations among pupils of

different countries at G C E "A" level, or its equivalent. The study was carried out nationally in schools in England and Wales, and the failure rate varied between 18% and 48% across different tasks. In other countries (Pakistan, Portugal and Cape Verde), however, the failure rate varied between 40% and 90% across different tasks.

The likely implications of such findings for schools in South Africa, with its multiplicity of language and cultural groups, are obvious, and a challenge for future investigations.

To summarize, there is a moderate, but significant, relationship between spatial visualization competence and achievement in certain areas of physical science. The inability to visualize pictorial depth in diagrams, and the inability to visualize rotation in molecular diagrams is widespread, and cause for concern. The use of photographs and properly depth-cued diagrams appear to assist three-dimensional perception, and the carefully organised use of molecular models appears to enhance spatial ability in organic chemistry.

#### IN BIOLOGY

Two recent, similar studies have investigated the relationship between varying levels of spatial visualization skill and

achievement on examinations in the topic mitosis/meiosis and DNA structure.

Bradley (1981:89-96) divided a class of college biology students into three treatment groups. One group (N=24) were taught using raised diagrams, the second group (N=24) studied using projected 35mm slides of the raised diagrams, and a third group (N=25) were taught with overhead projector transparencies and assembled models. Measures of spatial visualization ability (Paper Folding Test Vz-2) and level of cognitive development were administered to all subjects. It was found that :

- (1) the first two groups scored significantly higher than the third group on an Immediate Achievement test in biology;
- (2) the second group (slides) scored significantly higher on a Retention test than the other two treatment groups;
- (3) the significant effects of spatial visualization ability and level of cognitive development occurred consistently across the measures of Immediate and Retained achievement;
- (4) subjects with high spatial ability scored significantly higher than those with low spatial ability;
- (5) on a visual sub-test of the DNA topic test, students with high spatial visualization ability scored high marks regardless of treatment, but students low in spatial

ability scored markedly lower when learning with the transparencies and models as compared with the other two treatments.

Porter (1982) carried out a similar investigation, studying the effects of three instructional treatments on the Immediate and Retained Achievement of 139 rural tenth grade biology pupils studying the topics mitosis/meiosis, DNA/protein synthesis and homeostasis. One treatment used only two-dimensional materials such as diagrams, pictures or 2-D models; one treatment used only three-dimensional materials; and the third instructional treatment used a combination of both two- and three-dimensional materials. Amongst the conclusions drawn were :

- (1) The combination of 2-D and 3-D instruction appeared to have been the most effective strategy;
- (2) Spatial visualization ability had little relationship with achievement, but the achievement of students of varying levels of spatial ability tended to be consistent across gender;
- (3) The effects of treatment on achievement scores across :
  - (a) cognitive development
  - (b) spatial visualization ability, and
  - (c) genderappear to have been consistent.

The apparent contradictions between some of the findings of these two investigations should be noted; for example, the combination of 2-D and 3-D instruction appeared to have been the least effective treatment with Bradley (1981), but the most effective instructional treatment with Porter (1982). The anomalies may have occurred due to the small numbers of students assigned to the different treatment groups. (The present investigation found, for instance, that merely dividing a class of 264 engineering students into eleven sub-groups of 24 students alphabetically, sometimes produced cantly different findings from sub-group to sub-group. See Table 4.30.)

#### IN OTHER ACADEMIC SUBJECTS

Burnett & Lane (1980) administered two spatial visualization tests to 142 students before and after two years of college study. They found that students majoring in mathematics and the physical sciences improved more than those majoring in the humanities and social sciences. Female physical science majors improved more than male physical science majors. It appears that the study of selected academic subjects may indirectly or directly increase spatial visualization performance.

Many additional investigations have shown that spatial visualization scores are greater at the end of courses in geometry, and that mathematics achievement can be used as a valid index of spatial visualization ability. (See, for example, Martin (1966); Moses (1977); Eastman & Salhab (1978); Brendzel (1981); and Battista, et al. (1982).)

In the case of college mathematics, however, Lean & Clements (1981) found that spatial ability and knowledge of spatial conventions had less influence on performance than expected. An analysis of 116 students revealed that those who preferred to process mathematical information by verbal-logical means outperformed more visual students on tests at college level.

APPENDIX H

A BRIEF ACCOUNT OF THE FINDINGS OF RECENT  
INVESTIGATIONS INTO THE EFFECTIVENESS OF  
SPECIAL TEACHING OR REMEDIATION METHODS  
FOR STUDENTS DEFICIENT IN THREE-  
DIMENSIONAL VISUAL PERCEPTION

APPENDIX H.A BRIEF ACCOUNT OF THE FINDINGS OF RECENT INVESTIGATIONS INTO THE EFFECTIVENESS OF SPECIAL TEACHING OR REMEDIATION METHODS FOR STUDENTS DEFICIENT IN THREE-DIMENSIONAL VISUAL PERCEPTION.

Recorded in this appendix are the findings of 25 recent investigations into the facilitation of spatial performance by students in a variety of academic contexts. In order, findings are presented for the following areas : (1) General (2) Mathematics (3) Biology (4) Astronomy (5) Art and Engineering Drawing (6) Physics (7) Chemistry.

(1) General

Mercer (1979 : 264) has stated that some remedial students learn best via a visual input, whereas others may learn best via an auditory or a tactile input. In addition, a specific perceptual modality may represent a weak or inefficient pathway for learning. Thus, for optimum learning to occur, one must consider an individual's strong and weak modalities before planning instructional alternatives. Dyscalculics, for example, tend to learn best through the auditory modality, with two-dimensional figures and gross motor activities being recommended during initial remediation (Johnson and Myklebust, 1967 : 253-255).

Rovet (1974) contested Piaget's contention that the development of skills, including mental skills, depends mostly on active manipulations of objects in the real world. She used films to demonstrate a spatial process (mentally rotating an object) with varying degrees of explicitness. Her subjects were nine-year-old pupils from five schools near Toronto. Both the films and the criterion tests were based upon a task requiring the subjects to determine whether a pair of abstract cubic figures, oriented differently in space, were representations of the same object. In the most explicit film, one figure was shown to rotate about an axis to the orientation of the other figure. The partially explicit film showed spatial transformations with incomplete rotations while the implicit film showed no rotational transformations. It was concluded that film can

indeed/.....

indeed facilitate the development of cognitive skills and that this development depends on the explicit quality of the presentation as well as on the initial skills of the viewer.

Ross (1976) carried out an investigation with Nigerian junior secondary school pupils who experienced difficulties of depth perception in diagrams. He determined the remedial effect of various internal prompts incorporated into instructional programmes on the understanding of diagonal, horizontal and vertical spatial relationships in diagrams of framework structures. The treatments were (i) stereoscopic/planoscopic diagram presentation, (ii) colour/black outlining of diagram features, and (iii) audio/written exposition of diagram perception skills. All three treatments were found to be effective compared to controls ( $p < 0.005$ ). It was also found that the audio mode of exposition had a significant effect on the understanding of diagonal spatial relationships by first year pupils, which appears to corroborate Mercer's (1979) statement above. Ross's major finding was that the whole programme was effective in alleviating difficulties in the understanding of the three types of spatial relationships found in the diagrams.

In another investigation in Nigeria into remediating inadequate pictorial depth perception amongst grammar school pupils and teachers' training college students, Oyediji (1978) used an inexpensive self-instruction remedial programme on four conventional depth cues. The remedial stimuli included models, cued diagrams of the models and shadow-projection machines. The results of the experiment indicated that a well-formulated instructional programme could be as effective as any other remedial method with the Nigerian subjects.

## (2) Mathematics

Many investigations have established that spatial visualization ability is highly related to mathematical problem-solving performance

but/.....

but Wright (1982) showed that the use of selected visual adjuncts for enhancing the mathematical problem-solving ability of the 14-year-old pupils are equally useful for both high and low spatial ability subjects, and especially for female subjects.

At the college level Mundy (1980) pre-tested 250 first-semester calculus students at the University of New Hampshire on precalculus background, spatial visualization, and calculus background. The subjects were then assigned to one of three treatment conditions : audiovisual spatial training (AV), audio-visual-tactile spatial training (AVT), and a control condition. The content of the AV spatial training materials included slides of two- and three-dimensional tasks, rotations and three-dimensional image formation. The AVT training included models and manipulatives in place of certain spatial slides. The results suggested that the AV training was more influential for females than for males, and that the AVT training was more influential than the AV training, at least for males. It was also found that spatial training may play a role in the solution of certain types of integral calculus problems.

### (3) Biology

Szabo, Dwyer & De Melo (1981 : 179; 182) investigated the role of visuals in the learning of an instructional unit describing the human heart, its parts and their internal processes. They assumed that spatial material may be visually coded, even when presentation is auditory. They studied the effect of verbal instruction alone versus verbal instruction complemented by simple line drawings. Their findings statistically strongly supported the use of properly integrated visualization in the teaching-learning process, that is, in both the testing and instructional phases. They infer that the inclusion of line diagrams in the testing situation will improve the summative performance of visually weak students in biology.

### (4) Astronomy/.....

#### (4) Astronomy

Sonntag (1981) compared the effectiveness of three different teaching methods (planetarium lecture, classroom-celestial globe lecture, and planetarium/classroom-celestial globe lecture) and the effect of student spatial orientation ability (high, medium and low ability groups) on the learning of selected positional astronomy concepts at the University of Colorado. He found significant interactions between teaching method and spatial orientation ability on the post-test. In particular, the low and medium spatial orientation ability groups performed better on the post-test, if they were in the planetarium or planetarium/classroom celestial globe sections. Students in the high spatial orientation ability group, however, favoured the classroom teaching method. Sonntag concluded that students' spatial orientation ability is a factor that should be considered when designing instructional techniques in college astronomy classes that teach positional astronomy.

In another investigation Bishop (1980) studied the effects of two different teaching methods on the learning of basic topics in astronomy by junior high school pupils. The topics - such as the seasons, lunar phases and planetary positions and motions - all stressed projective spatial ability. The two teaching methods were a traditional planetarium treatment, and a developed experimental approach using the Karplus Learning Cycle (based on the work of Piaget), pupil model manipulation and pupil drawing. The superiority of the developed experimental unit was demonstrated on both immediate and delayed post-tests relative to a third, no-treatment, control group. Pupils who had experienced the traditional planetarium unit also performed significantly better on a unit test in astronomy than the no-treatment group. (The fact that the majority of pupils in the experimental group were unable to answer correctly 75% of the questions on any of the six astronomy post-tests, however, implies that the spatially weak pupils scored particularly badly, despite the

"favourable"/.....

"favourable" teaching methods employed. This is surely cause for concern).

(5) Art and Engineering Drawing

The remediation of perceptual-motor skills has been largely directed towards young children, but St John (1978) explored the effects of a special, spatial, developmentally-based, sequenced programme of 21 remedial art sessions on the visio-spatial-motor skills of older (9 - 11 years), neurologically-impaired pupils who had visuo-spatial disabilities. Compared with a control group, the experimental group significantly improved in drawing ability. The programme required some adjustments and modifications for each child, and the degree of gain for each individual was linked to (a) the type of deficit, whether visuo-spatial or motor, (b) the severity of the deficit, (c) self-acceptance of disabilities and emotional maturity, and (d) predominantly global or perceptual style. The findings of this investigation suggest the necessity for trained visual arts specialists who would be sensitive to the diagnostic and prescriptive dimensions of a programme for grossly spatially disabled students in art or engineering drawing.

Smail (1983) demonstrated that the spatial visualization skills of 11-year-olds may be enhanced by twelve weeks' introductory lessons in technical drawing and three-dimensional work in wood and metal. She also produced evidence that sex differences in spatial visualization scores are the results of environmental rather than innate factors, and can be modified by experience.

Davies (1976; 1982) has developed remedial techniques for spatially disadvantaged engineering students. These involve the building of simple models of the objects which the student is having difficulty drawing, as well as the use of stereoscopic drawings to illustrate the object in three-dimensional space.

These/.....

These have been used and extended by Van der Merwe, under the leadership of Kemp (1983 : 258) at the University of the Witwatersrand, and the resulting support course in engineering drawing has been effective in developing spatial perception abilities.

Davies (1982) has also described a number of elementary remedial exercises which may be given to young scholars to develop spatial perception, such as dot-to-dot drawings, pictures with hidden objects, origami, jig-saw puzzles, and a form of card game Snap, involving discrimination between shapes. The use of visual games, of the type illustrated in the book by Berloquin (1980), can also be useful in expanding this visual competence.

#### (6) Physics

In a study of the effect upon physics achievement of the use of an eleven-hour spatial reasoning intervention phase in the teaching of introductory college physics, Seeber (1981) found that the intervention training in perception, rotation-orientation and visualization had its greatest impact on post-test scores of perception ability and, to a lesser extent, on rotation-orientation scores. He concluded that spatial ability can be trained, but, unfortunately, his investigation could not extend to students who voluntarily withdrew from the physics course, and who were significantly inferior in perception ability compared to the subjects who continued on in the course. It is conceivable, but by no means certain, that his remedial methods may have been less successful with such students.

#### (7) Chemistry

Talley (1973) taught 102 freshman chemistry students to translate chemical interactions into concrete structured molecular models. These students performed significantly better on summative achievement tests as compared to students who were not taught to visualize with concrete models. See also Baker & Talley (1974).

In a later/.....

In a later investigation with over 300 chemistry pupils in high school courses, Gabel & Sherwood (1980) found that subjects who manipulated models over a long period of time (at least a semester), scored significantly better on achievement tests in chemistry than pupils who merely watched the teacher manipulate the models over the same period of time. Formal thinkers and concrete thinkers made similar gains. These findings partially contradict those of Hyman (1982), indicating the need for further investigation with length of time as a continuous variable.

Dickson (1974) studied the comparative effectiveness of the use of models and photographs for the acquisition of three-dimensional concepts in the stereochemistry of optical activity. The subjects were 297 pupils in ten schools in Northern Ireland. The results showed that both programmes were effective, but that one programme was not significantly better than the other.

In another investigation, Jusoh (1979) studied the effect of three possible programmes in improving third and fourth year high school pupils' understanding of the pictorial representation of rotation in molecular structures about an axis. The three methods were the diagram programme, the model programme and the shadow programme. The results indicated that only the latter two programmes did improve pupils performance, and that there was no difference between them in effectiveness.

Holford (1969) investigated the feasibility of using stereoscopic presentation to improve the visualization of spatial relations in structural chemistry amongst 67 sixth form pupils. Compared to the use of single photographs of structured models, the use of stereoscopic photographs in the programme and post-test led to a significantly better performance on tests dealing with the structure of three-dimensional crystals. Worsnop (1975), however, found that the use of stereoscopic projection was ineffective as a remedial aid to improving depth perception amongst poor 14-year-old English perceivers.

In an/.....

In an attempt to remediate difficulties connected with Nigerian pupils' ability to visualize rotation in molecular diagrams, Eniayeju (1981) used 35mm slides containing diagrams of rotated molecular models, projected in a sequence of 10°, 30° or 60° jumps by using the lap-dissolve or conventional slide projection technique. 252 pupils were randomized into a 3 x 4 factorial design involving three rotation shifts crossed with four remediation groups. Analysis of the post-test scores showed that, coupled with remediation in four pictorial depth cues, the lap-dissolve treatment, involving 10° shifts in the presentation of diagrams, was the most effective.

In a related investigation El Farra (1982) designed a remediation procedure to improve 105 English students' understanding of the diagrammatic representation of reflection. The experiment involved the use of nine video programmes based on 35mm slides containing a sequence of 180 diagrams showing ten theoretical steps of reflection performed on each of 18 molecular structures. However, the programmes differed in their dissolve times (3,4,5 seconds), and between successive diagrams and their exposure intervals (5, 7½, 10 seconds). Analysis of scores on the Reflection Test indicated that (i) five of the programmes were significantly effective as remedial devices; (ii) the different exposure-intervals significantly affected the performance on the test; and (iii) changing the dissolve time did not have a significant effect.

Finally, Shubber (1982) also investigated the possibility of using specially designed remediation programmes to alleviate the problems encountered by secondary and tertiary Bahrainian students. Six types of remedial programme were recorded on video tapes and tested on students who showed difficulty in visualizing rotation from molecular diagrams. Each programme consisted of models rotating with one of three different speeds, and either with, or without, shadow prompts. Analysis of post-test results showed that (i) experimental groups in two out of five educational

institutions/.....

institutions demonstrated a significant improvement in understanding rotation in molecular diagrams; (ii) varying the speed of rotation of the molecular models did not affect understanding; and (iii) remediation by no-shadow programmes were found to be more effective than remediation by shadow programmes.

APPENDIX I

THE DESIGN, DEVELOPMENT,  
REFINEMENT AND PROPERTIES  
OF THE AUTHOR-CONSTRUCTED  
GEOMETRIC SPATIAL BATTERY

APPENDIX I

THE DESIGN, DEVELOPMENT, REFINEMENT AND PROPERTIES OF THE AUTHOR-  
CONSTRUCTED GEOMETRIC SPATIAL BATTERY.

1. The need for an author-designed geometric spatial test

The geometric spatial battery used with advanced medical and science undergraduates in the present investigation was constructed and developed by the author in collaboration with two qualified teachers of mechanical drawing. The decision to opt for the author -designed exercises rather than commercially-available geometric spatial tests resulted from several considerations.

Firstly, the readily available NFER Spatial Test 3, which was developed in England primarily for a target population of high school pupils, proved to be too easy for a sample of second-year anatomy students, nearly half of whom were spatially weak, ( $\bar{x} = 83.9\%$ ,  $N = 27$ ). Besag and Greene (1981 : 53) point out :-

The appropriateness of any test should always be questioned; (and) if the test is not normed on a population similar to the population to be tested, a more appropriate test, or no test should be used.

They also say that when non-standard youth are matched against standardized test norms for the purpose of track placement or labelling, anomalous results can be obtained (page 29).

Secondly, the writer's correspondence with Educational Testing Service (which is reproduced in Appendix E) indicates a dearth of tests appropriate to the present study.

Thirdly, Just (1979 : 16) points out that it is debatable whether certain tests which have been used in studies correlating academic success with spatial ability, are actually measures of flexibility of closure. He singles out the Embedded Figures Test, the Rod and Frame Test, the Group Embedded Figures Test and the Body Adjustment Test, and comments that all of these may not measure a unitary factor, since they do not always correlate. In his doctoral dissertation Just investigated the spatial abilities of dental students using his own battery of geometric spatial

exercises/....

exercises in place of the ETS Kit of Factor-Referenced Cognitive Tests with which he was particularly familiar. The present author has followed suit.

Finally, since the prime purpose of the present study is the diagnosis of specific outright academic failure, rather than the establishment of general correlational trends, it seems appropriate that tests of spatial ineptitude should be developed, modified and improved as an integral part of the investigation itself.

## 2. The design and development of the geometric spatial battery

A number of major considerations influenced the nature and composition of the author-designed geometric battery of sub-tests.

Firstly, a preliminary analysis of past examination papers in anatomy (Appendix J) suggested that students who lack one or more of the following spatial skills may experience learning difficulties in anatomy:-

- i) the ability to orientate the features of a body under rotation;
- ii) the ability to reconstruct in imagination and to visualize the whole shape of a solid body given its component orthogonal sections;
- iii) the ability to visualize and draw accurate cross-sections through a given body; and
- iv) the ability to recognize and draw from memory a common object given only a verbal description of it.

Secondly, Just (1979 : 16 - 17) says that measures of spatial orientation and of visualization ability are generally tests which require the subject to restructure mentally and/or rotate a figure in two- or three-dimensional space. Spatial orientation usually requires only rotation; visualization requires both rotation and restructuring. Often these tasks require the subject to visualize an object in a reference frame which differs from that in which it is presented.

Typical paper and pencil tests of spatial orientation include the Cube Comparisons Test in which subjects must mentally rotate two

or more/.....

or more drawings of cubes to determine if they are the same, and a rotation of objects test, in which subjects must determine whether irregularly shaped objects have been rotated within a plane or lifted out of the plane and flipped over. Typical paper and pencil tests of visualization require subjects to put together in imagination several drawings to form a pre-determined figure; or to visualize solid forms created by cutting and folding two-dimensional drawings.

A combination of these first two major considerations resulted in the construction of the following five sub-tests in the geometric battery of spatial tests :-

<u>RV</u>	Rotation, visualization and juxtaposition of geometrical objects in three dimensions.
<u>RC</u>	Rotation of cubes in space.
<u>SYN</u>	Synthesis of sections of common geometrical objects.
<u>SEC</u>	Sectioning of geometrical solids.
<u>IM</u>	Image-synthesis.

The fifth task, IM Image-synthesis, was based on the suggestion of Morris and Upton (1979), but this sub-test was eliminated from the geometric battery subsequent to February 1981 when it failed to yield consistently significant results.

Whereas the first two sub-tests RV and RC were constructed using a multiple choice format, the sub-tests SYN and SEC required testees to make sketches. Van Arsdel (1983 : 75) states that requiring subjects to draw figures can be used to assess field-dependence/independence in individuals above the age of ten years, although very little research, if any, appears to have been carried out into the spatial significance of sketching errors made by older subjects.

A copy of the refined geometric battery appears on pages I8 to I19 of this appendix. In August 1980 and August 1983 a brief sub-test of anatomical spatial ability was added to the geometric spatial battery. This was composed by Dr Fredman of the Department of Anatomy at the University of Cape Town and was designed to test students' ability to synthesize into a whole the three orthogonal sections of a tissue or organ in the body. It pre-supposed an elementary knowledge of anatomy. FRED, the Fredman synthesis of anatomical sections tests, is reproduced in Appendix J.

Time limits were imposed for each of the sub-tests in the geometric battery in 1980 only. Time limits were abandoned after 1981 when it was demonstrated that spatially weak students dramatically underperformed with or without them. This finding is in harmony with that of Lohman (1979).

A pilot study using the unrefined geometric spatial battery was conducted with 43 anatomy students during the interviews held in August 1980. 37 of these students were mid-year failures, and 5 were volunteers. An item analysis of their responses quickly led to the elimination of many questions which were too easy, or which were ambiguous. The students' scores were then re-calculated using the refined sub-tests, and these were used for the subsequent spatial statistical analysis.

The refined geometric battery was then given to a panel of nine lecturers in anatomy for further possible purification. Eight of the nine lecturers scored at least 90% on the battery. (One lecturer who scored less was old and retired, and appeared to confuse right and left in three dimensions.)

### 3. Properties of the geometric spatial battery

On the following pages are tabulated

- i) the properties of the geometric spatial battery (means, ranges and SD's) for the different populations of undergraduates;
- ii) the pass marks set for the four sub-tests of the refined geometric spatial battery; and
- iii) intercorrelations amongst the sub-tests of the geometric spatial battery for POPULATIONS I and II.

Table I.1    Properties of the geometric spatial battery  
for the different populations : Means, ranges  
and SD's

	POPULATIONS	N	GEOMETRIC SPATIAL BATTERY		
			MEAN	RANGE	SD
I	Anatomy : mid-year failures plus five volunteers	37 + 5	63.3%	23% - 92%	19.6%
II	Anatomy : novices	154	77.6%	32% -100%	15.4%
IIR	Anatomy : 19 mid-year failing novices plus 8 fail/repeats	27	64.0%	27% - 89%	19.1%
VI	Astronomy : novices	56	66.9%	21% - 96%	19.8%
II	Astronomy : End-of-year students with intact records	25	73.0%	20% -100%	14.9%
II	Engineering Drawing : novices	273	76.9%	0% -100%	15.6%
IX	Clinical Remedial Teachers	15	34.5%	15% -84%	14.6%

Table I.2      Pass marks set for the four sub-tests of  
the refined geometric spatial battery

<u>SUB-TEST</u>	<u>MAX. POSSIBLE SCORE</u>	<u>PASSING SCORE</u>
RV	8	5
RC	5	2
SYN	5	2½
SEC	15	6
<hr/>		
FOR THE BATTERY AS A WHOLE	33	22

Table I.3      Intercorrelations amongst the sub-tests of the  
geometric spatial battery for POPULATIONS I and II

POPULATION I (1980) + 5 VOLUNTEER ANATOMY STUDENTS (N = 43)

	RV	RC	SYN	SEC
RC	0.42**			
SYN	0.29*	0.42**		
SEC	0.30*	0.26	0.51**	
FREDMAN	0.35*	0.23	0.39**	0.21

\* p < 0.05

\*\* p < 0.01

POPULATION II (1981) (N = 154)

	RV	RC	SYN	SEC
RC	0.38**			
SYN	0.42**	0.39**		
SEC	0.51**	0.49**	0.53**	

\*\* p < 0.01

I ROTATION AND VISUALIZATION IN THREE DIMENSIONS

Each of the following eight items consists of a block with an opening or openings and five other blocks with projecting points.

From the alternative blocks in each item chose the one whose projecting point or points fit exactly into the block with the opening or openings.

In each item there is only one block which fits.

Example

(   ) a.

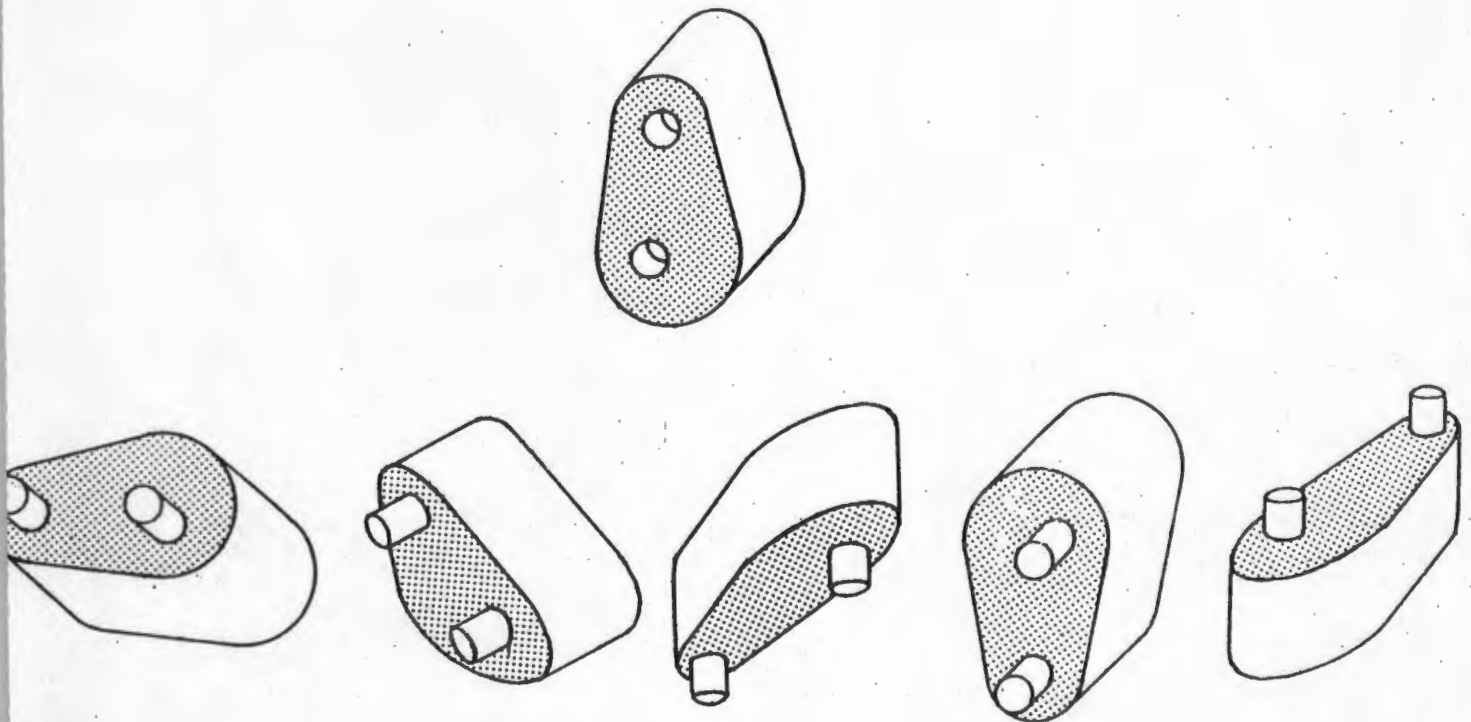

A.

B.

C.

D.

E.

Block B is the only one that fits exactly on the block with the openings in such a way that the projecting points fit into the openings. You would write "B" in the brackets in front of a, thus: ( **B** ) a.

Attempt an answer to every question, even if sometimes you have to guess.

( ) 1.

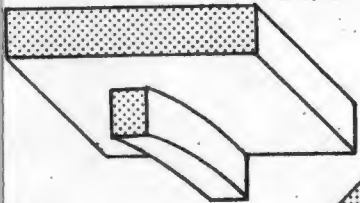
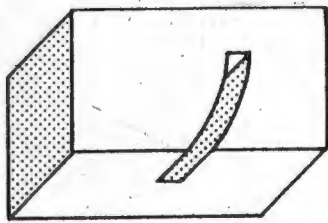

A.

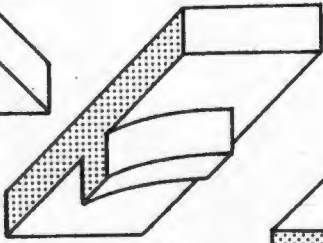

B.

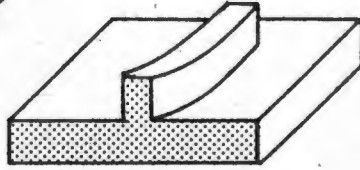

C.

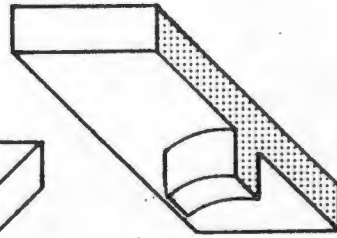

D.

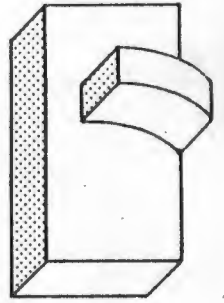

E.

( ) 2.

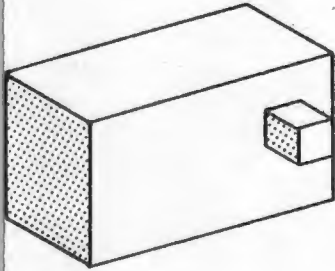
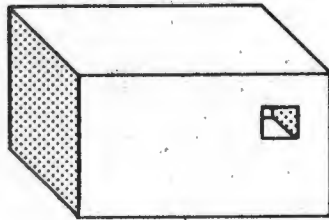

A.

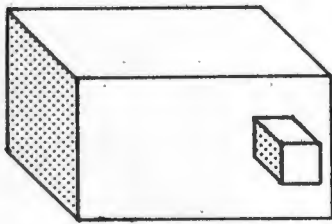

B.

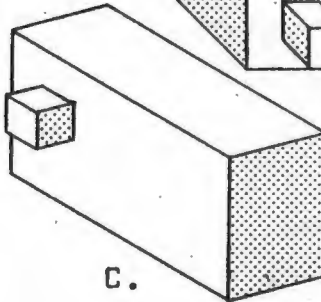

C.

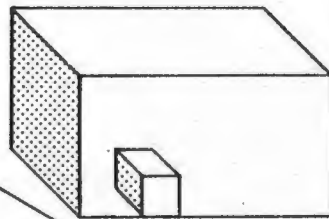

D.

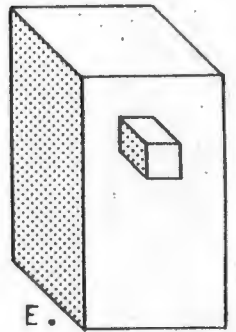

E.

( ) 3.

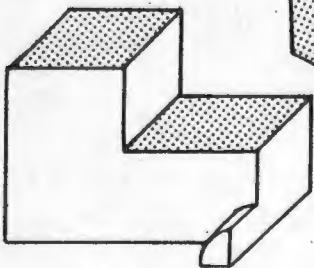
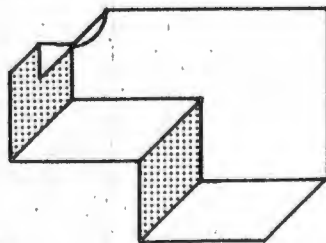

A.

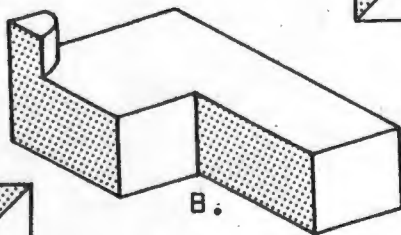

B.

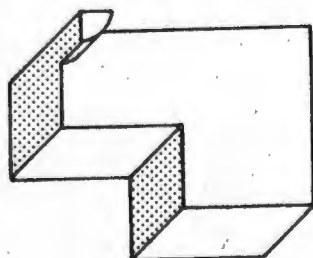

C.

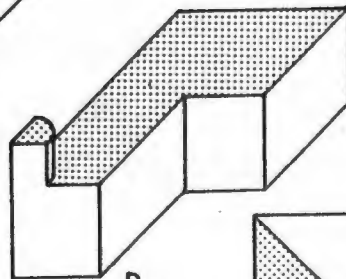

D.

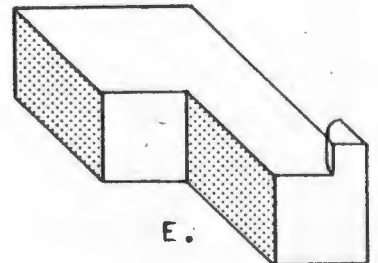

E.

( ) 4.

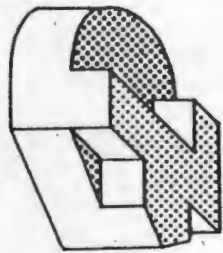
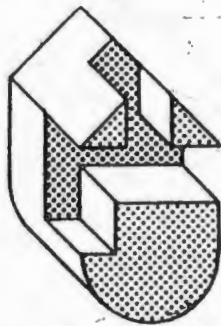

A.

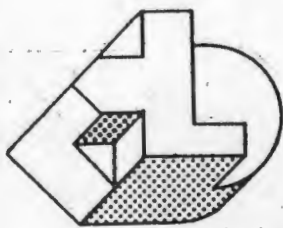

B.

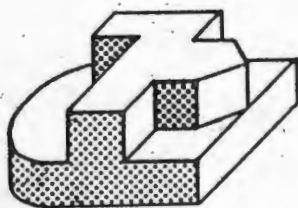

C.

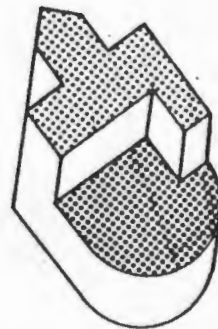

D.

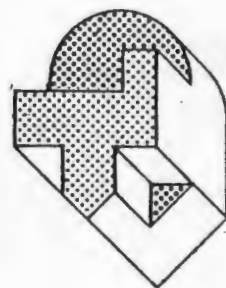

E.

( ) 5.

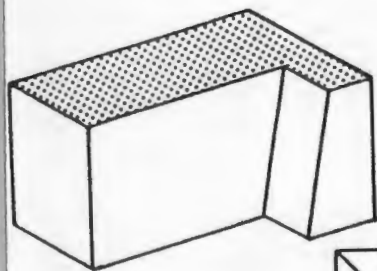
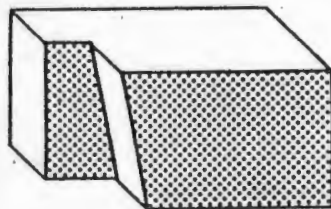

A.

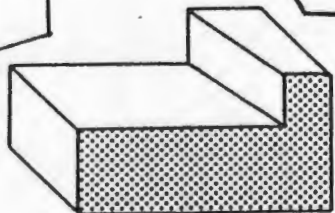

B.

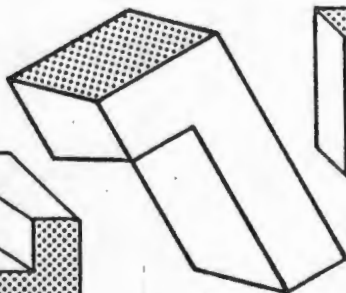

C.

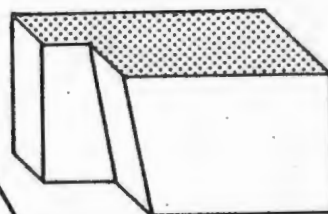

D.

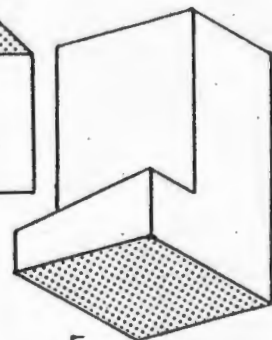

E.

( ) 6.

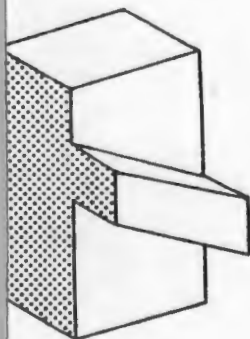
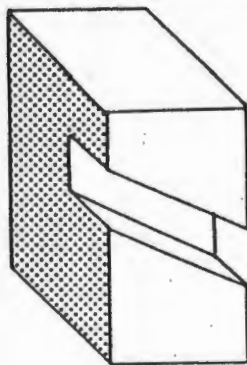

A.

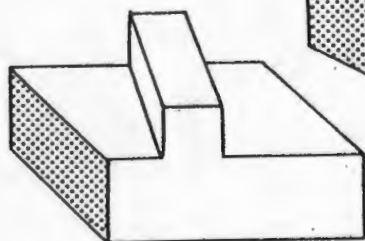

B.

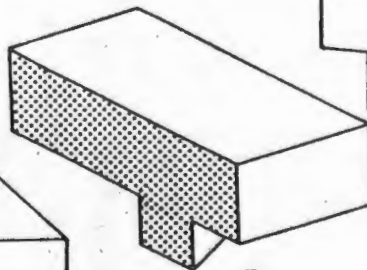

C.

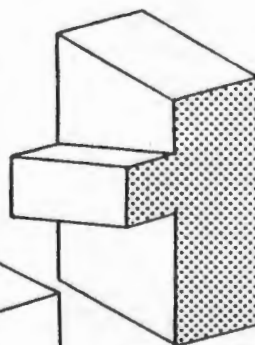

D.

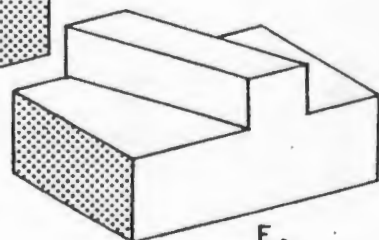

E.

7. ( )

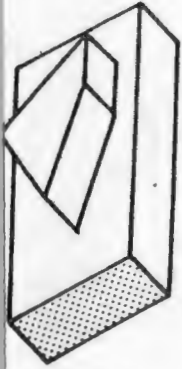
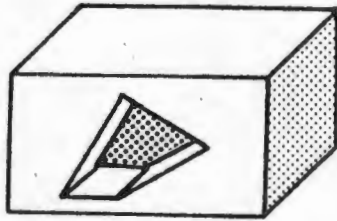

A.

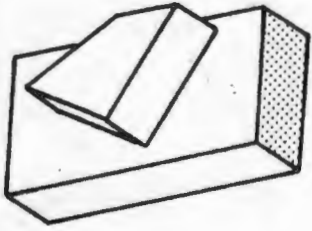

B.

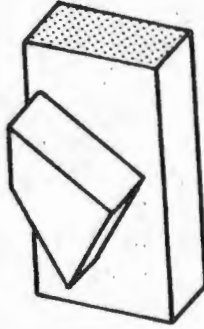

C.

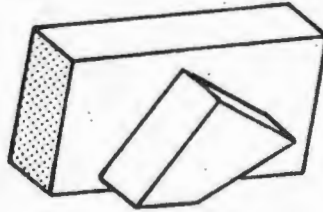

D.

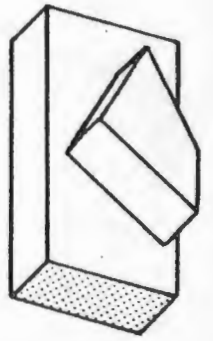

E.

8. ( )

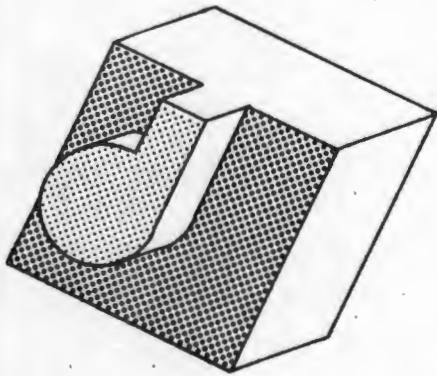
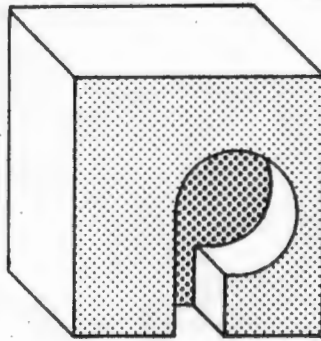

A.

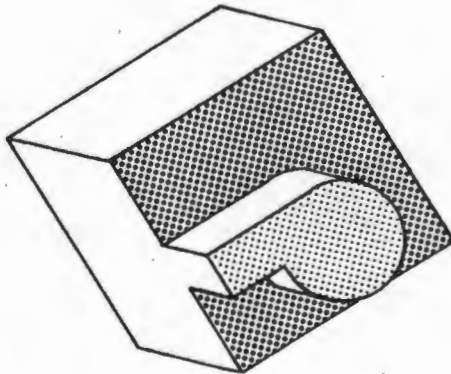

B.

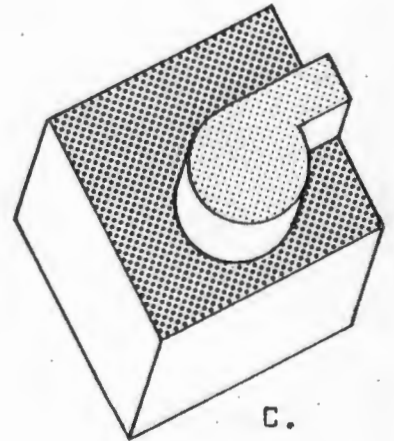

C.

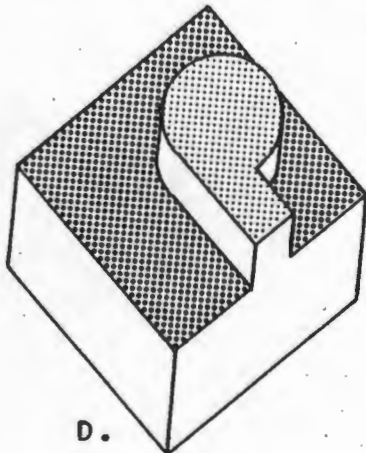

D.

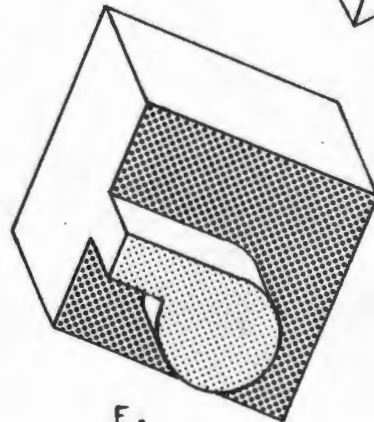

E.

II ROTATION OF CUBES

Find the one cube that does not belong with the other four, and write your answer inside the brackets in front of the number of each item.

The cubes may be rotated or turned over in any direction. In every case four of the five cubes are identical. Name the odd one out.

) 1.

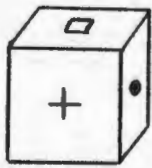

A

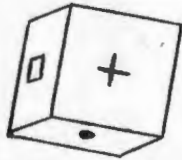

B

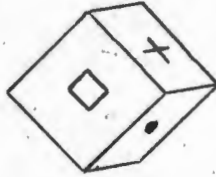

C

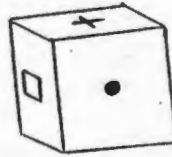

D

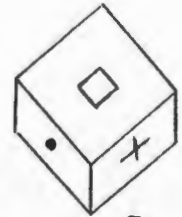

E

) 2.

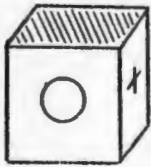

A

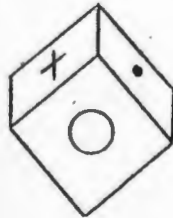

B

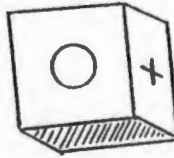

C

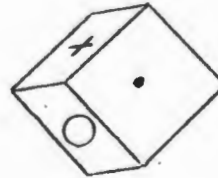

D

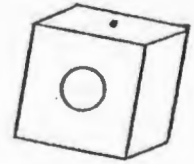

E

) 3.

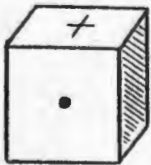

A

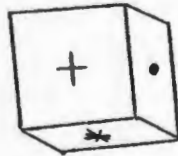

B

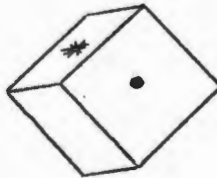

C

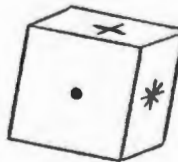

D

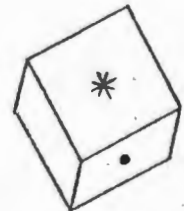

E

) 4.

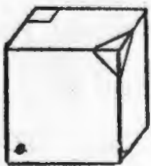

A

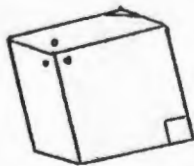

B

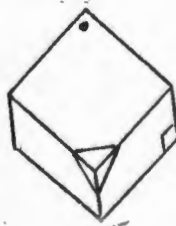

C

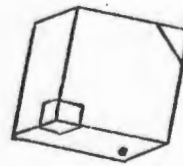

D

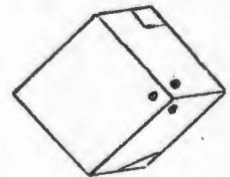

E

) 5.

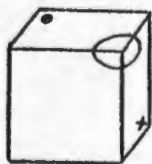

A

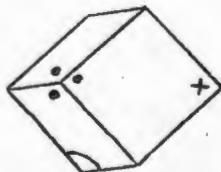

B

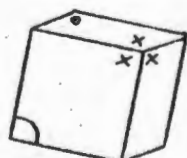

C

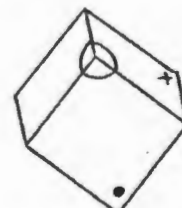

D

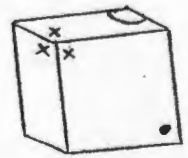

E

NAME : \_\_\_\_\_

### III SPATIAL SYNTHESIS TEST

When any object, such as a brick, is placed on a table, it can be cut into two parts in many ways. In this test we will make only three different cuts which we will call (i) a north-south vertical cut; (ii) an east-west vertical cut; and (iii) a horizontal cut.

Suppose, for example, we wish to saw in half a long block of wood which has two square ends:-

(i) The north-south vertical cut

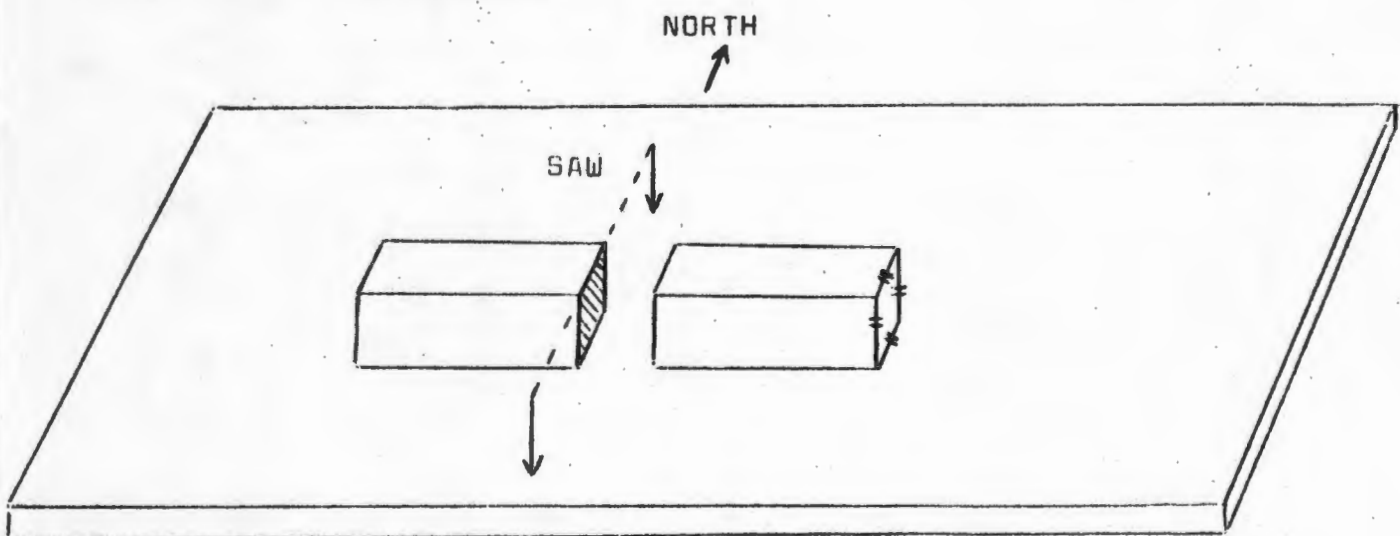

In the above diagram the block has been sawn in half by a north-south vertical cut. The shaded section indicates the newly-sawn face of the wood, and is, in fact, a square.

(ii) The east-west vertical cut

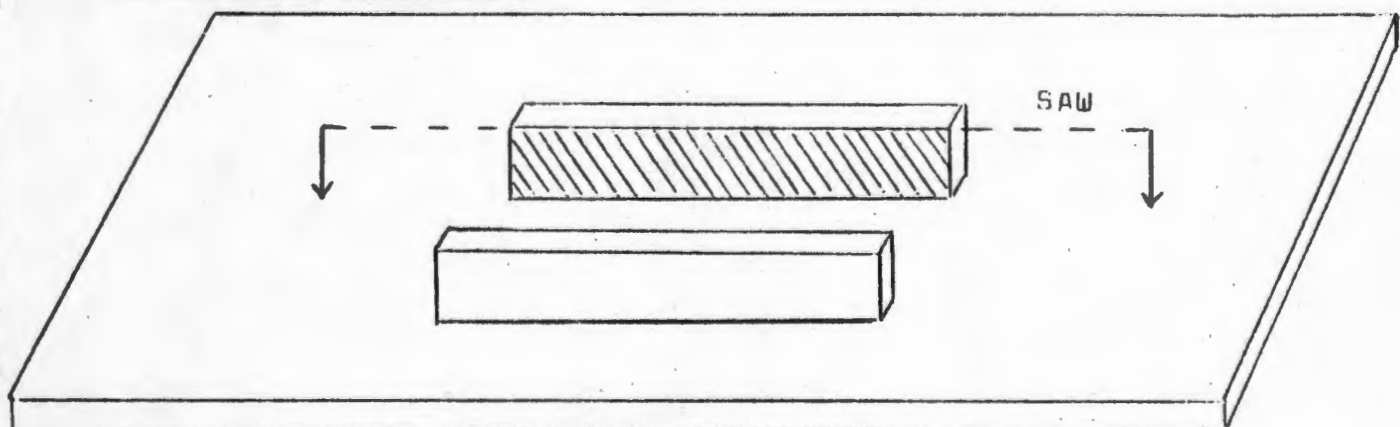

In the preceding diagram the original block has been sawn in half by an east-west vertical cut. The shaded section indicates the newly-sawn face of the wood, and is a rectangle.

(iii) The horizontal cut

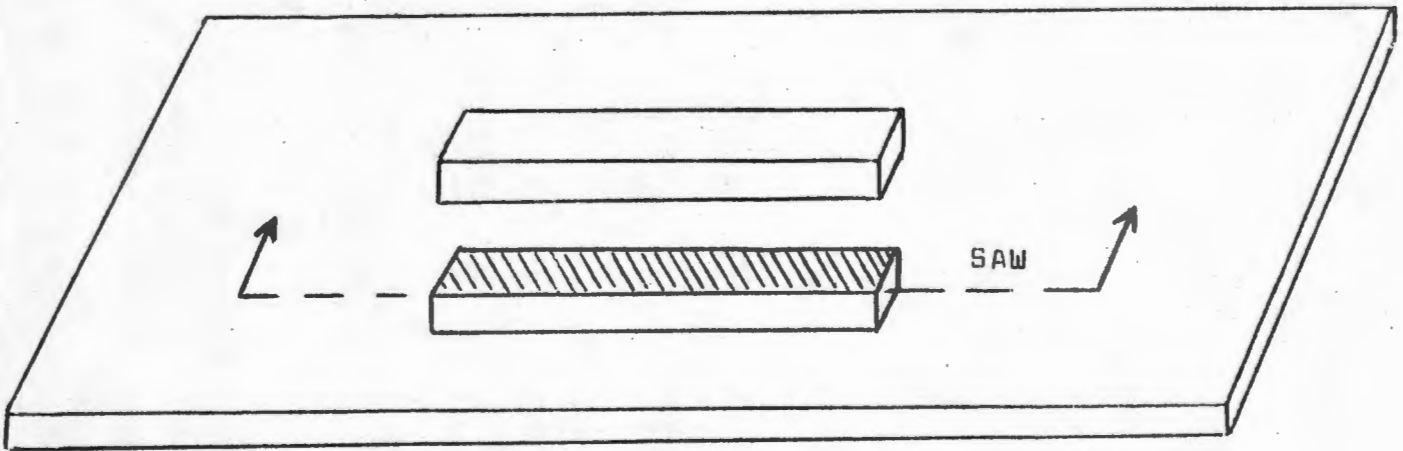









In the above diagram the original block has been sawn in half by a horizontal cut. The shaded section indicates the newly-sawn face of the wood, and, in this case, is also a rectangle.



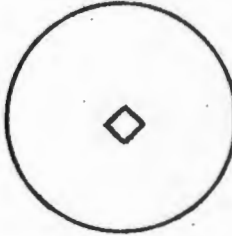

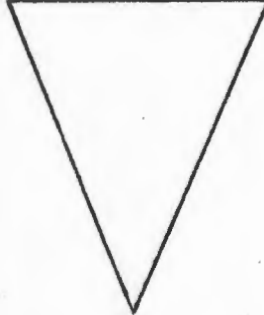

In the following items you are given diagrams of the north-south vertical section, the east-west vertical section and the horizontal section through a three-dimensional object. You are required to deduce the shape of the whole object from its three sections, and to sketch it in the empty space alongside its sections.

There is only one answer per item, i.e. one three-dimensional object deduced from the three two-dimensional sections drawn. If you make a mistake with your sketch, draw your improved sketch on the back of this page, and number the item appropriately.

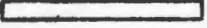
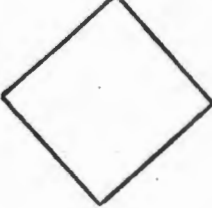
Finally, describe each object in words by giving it a label or name, e.g.

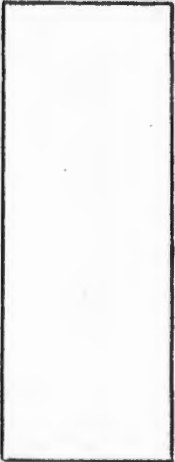
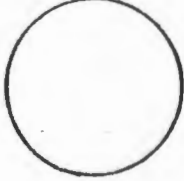
"a square-based pyramid."

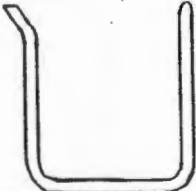





	NORTH-SOUTH VERTICAL SECTION	EAST-WEST VERTICAL SECTION	HORIZONTAL SECTION	ANSWER
EXAMPLE				 <p data-bbox="1181 616 1428 772">A solid hemisphere with a square hole through its axis.</p>
1				
2				

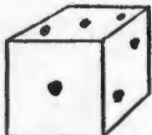

	NORTH-SOUTH VERTICAL SECTION	EAST-WEST VERTICAL SECTION	HORIZONTAL SECTION	ANSWER
3				
4				
5				

NAME : \_\_\_\_\_

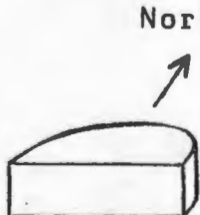
IV SECTIONING TEST

The five objects given below are to be viewed when sectioned in three planes at right angles to each other, as described in the previous test. For each section begin with the original object, slice it in the plane indicated, and sketch the appearance of the resulting two-dimensional section.

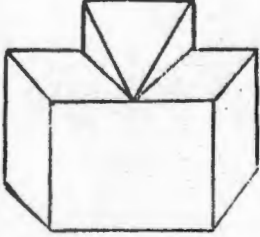
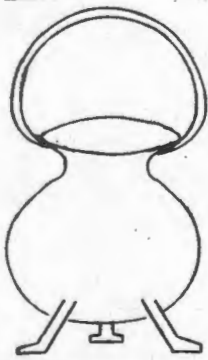
	OBJECT	NORTH-SOUTH VERTICAL SECTION	EAST-WEST VERTICAL SECTION	HORIZONTAL SECTION
EXAMPLE	DICE 			
1	A SEMI-CIRCULAR PRISM North 			
2	A HORIZONTAL PENCIL, OF HEXAGONAL CROSS- SECTION, WHOSE TIP POINTS NORTH North 			

	OBJECT	NORTH-SOUTH VERTICAL SECTION	EAST-WEST VERTICAL SECTION	HORIZONTAL SECTION
3	<p style="text-align: center;">North ↑</p> 			
4	<p>COOKING POT</p> 			
5	<p>A COIL OR SPIRAL STRETCHED VERTICALLY</p> 			

NAME : \_\_\_\_\_

IX DRAWING

In each space make a drawing of the object named there. Make the drawings large, as shown in the diagram of the door in the first space. Do not spend a lot of time on detail, but be sure that you draw the outline of the shape correctly. Use a pencil and rubber if you think you may wish to alter your drawings.

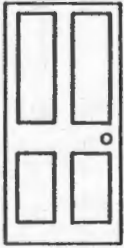
<p>(1)</p>  <p>DOOR</p>	<p>(2)</p> <p>SPADE</p>	<p>(3)</p> <p>COKE OR PEPSI BOTTLE</p>
<p>(4)</p> <p>KRAAL</p>	<p>(5)</p> <p>BUNSEN BURNER</p>	<p>(6)</p> <p>SHOE</p>
<p>(7)</p> <p>MATCHBOX</p>	<p>(8)</p> <p>BUS</p>	<p>(9)</p> <p>FRONT VIEW OF JAMESON HALL (WITH ITS SIX PILLARS)</p>

APPENDIX J

SAMPLE COPIES OF THE INSTRUMENTS

USED WITH POPULATIONS I TO VIII

THE FREDMAN SYNTHESIS OF  
ANATOMICAL SECTIONS TEST

SAGITTAL

CORONAL

TRANSVERSE

1

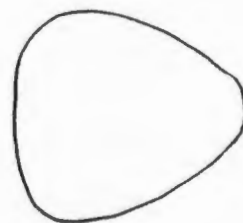

2

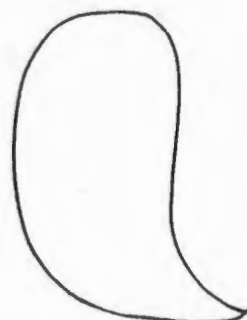

3



4

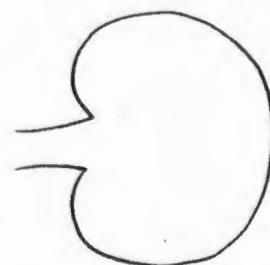
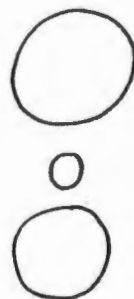

5

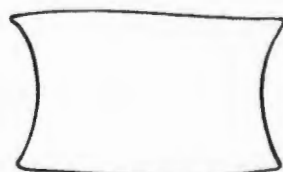
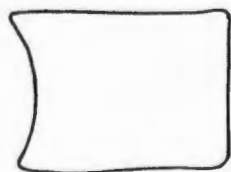

6

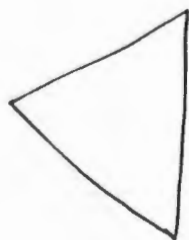

3D VIEW

SAGITTAL

CORONAL

TRANSVERSE

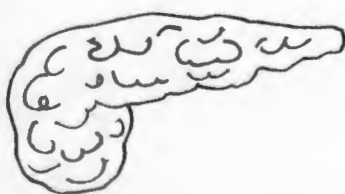
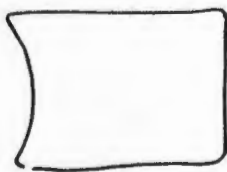
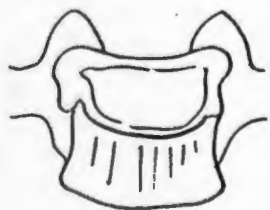
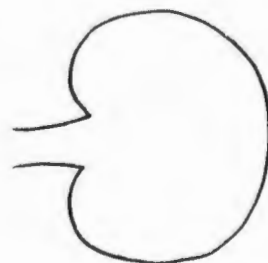
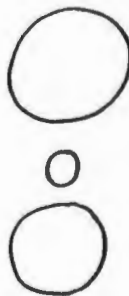
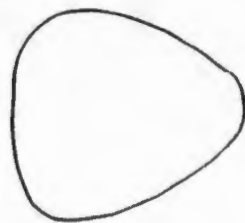

ERROR ANALYSIS OF THE FREDMAN TEST  
FOR 37 FAILING STUDENTS INTERVIEWED  
IN AUGUST 1980

Question No.	ANSWER	NUMBER OF STUDENTS			ERRORS
		CORRECT	WRONG	NO ATTEMPT	
1	HEART	13 = 35%	9	15	STOMACH (7) RT. ATRIUM (1) LIVER (1)
2	LUNG/ RIGHT LUNG/ PLEURA	33 = 89%	11	3	PANCREAS (1)
3	LIVER	24 = 65%	5	8	SPLEEN (4) ADRENAL GLAND (1)
4	FOETUS/ EMBRYO	12 = 32%	22	3	KIDNEY (22)
5	VERTEBRAL COLUMN/ VERTEBRA/ BODY OF VERTEBRA/ LUMBAR VERTEBRA	12 = 32%	11	14	KIDNEY (2) VEIN (1) SPLEEN (1) MEDIASTINUM (1) LIVER (1) CELL (1) MUSCLE (1) DIAPHRAGM (1) TRACHEA (1) ABDOMEN (1)
7	PANCREAS	15 = 41%	4	18	SPLEEN (1) RIB (1) INTESTINE (1) BRAIN SINUS (1)

SAMPLE EXAMINATION PAPER :

MCQ ANATOMY

UNIVERSITY EXAMINATIONS : OCTOBER/NOVEMBER 1980

ANATOMY (2nd year MB ChB & B Sc Med.)

MULTIPLE CHOICE QUESTIONS

C E R T I F I C A T I O N

KINDLY NOTE:

1. Make sure your name and computer number appear on your answer sheet
2. Please mark your answers 1 to 5 in INK and make sure that your figures are clear and do not resemble each other. If you do not know the answer mark 0 or leave blank. If you wish to alter an answer please cross your old answer out first - do NOT alter figures as they stand - or no attempt will be recorded.

## UNIVERSITY EXAMINATIONS : OCTOBER/NOVEMBER 1980

ANATOMY (2nd year MB ChB & B Sc Med.) MULTIPLE CHOICE : CERTIFICATION

Complete the following sentences (questions 1 - 17) by choosing the best of the alternatives set out:

1. The superior constrictor muscle of the pharynx is supplied by:

- 1 cranial accessory (to the vagus) nerve
- 2 glossopharyngeal nerve
- 3 cervical sympathetic fibres
- 4 superior laryngeal nerve
- 5 recurrent laryngeal nerve

2. The atlas has:

- 1 a body
- 2 a spine
- 3 an anterior tubercle on its transverse process
- 4 a large vertebral foramen
- 5 all of the above

3. The external carotid artery ends by dividing into its two terminal branches:

- 1 in relation to the neck of the mandible
- 2 at the superior border of thyroid cartilage
- 3 superficial to parotid gland
- 4 related to the angle of the mandible
- 5 none of the above

4. The dilator pupillae muscle is supplied by:

- 1 the oculomotor nerve
- 2 the ophthalmic nerve
- 3 the abducent nerve
- 4 the sympathetic nerve
- 5 none of the above

5. The jugular foramen lies between the occipital bone and the \_\_\_\_\_ bone:

- 1 sphenoid
- 2 petrous temporal
- 3 parietal
- 4 maxillary
- 5 none of the above is correct

6. Features of the interatrial septum are:

- 1 crista terminalis
- 2 limbus fossae ovalis
- 3 sinuatrial node
- 4 intervenous tubercle
- 5 none of the above

contd.....

7. The immediate posterior relation of the pericardium covering the left atrium is:
- 1 the oesophagus
  - 2 the trachea
  - 3 the thoracic duct
  - 4 the vertebral column
  - 5 the left crus of the diaphragm
8. Increased gastro-intestinal peristalsis involves nerve fibres classified as:
- 1 sympathetic afferent
  - 2 sympathetic efferent
  - 3 parasympathetic afferent
  - 4 parasympathetic efferent
  - 5 somatic afferent
9. Arrange the following 5 items in a function sequence:  
Which of the 5 items comes FOURTH on your list?
- 1 pons
  - 2 internal capsule
  - 3 pyramid
  - 4 precentral gyrus
  - 5 crus cerebri
10. The termination of the gonadal veins is as follows:
- 1 both veins end in the inferior vena cava
  - 2 the right vein ends in the right renal vein and the left ends in the inferior vena cava
  - 3 the right vein ends in the inferior vena cava and the left ends in the left renal vein
  - 4 both end in renal veins
  - 5 both end in the internal iliac veins
11. Psoas major arises in part from:
- 1 12th rib
  - 2 iliopubic eminence
  - 3 lateral arcuate ligament
  - 4 thoracolumbar fascia
  - 5 lumbar intervertebral discs

contd....

12. The portal vein and its tributaries:

- 1 drain midgut derivatives only
- 2 drain foregut and midgut derivatives only
- 3 do not communicate with systemic veins
- 4 have numerous venous valves
- 5 none of the above is correct

13. The ductus deferens hooks round the lateral aspect of:

- 1 the obliterated umbilical artery
- 2 deep circumflex iliac artery
- 3 inferior epigastric artery
- 4 medial umbilical ligament
- 5 all of the above

14. Recto-uterine pouch (of Douglas):

- 1 lies anterior to the uterus
- 2 transmits the inferior rectal vein
- 3 contains the uterine tubes (Fallopian)
- 4 forms part of the anal canal
- 5 none of the above is correct

15. Inversion of the foot is brought about by contraction of the following muscles:

- 1 peroneus longus and tibialis posterior
- 2 peroneus longus and peroneus brevis
- 3 tibialis anterior and tibialis posterior
- 4 peroneus longus and tibialis anterior
- 5 none of the above is correct

16. Closely related to flexor digitorum superficialis is:

- 1 musculocutaneous nerve
- 2 ulnar nerve
- 3 median nerve
- 4 radial nerve
- 5 deep branch of radial nerve

17. When the truncus arteriosus divides, the aorta is separated from:

- 1 pulmonary vein
- 2 subclavian artery
- 3 pulmonary trunk
- 4 common carotid artery
- 5 none of the above is correct

Select the INCORRECT statement from statements 1 to 4 in the following questions (18 - 70), or choose 5 if all four statements are correct

18. Muscles attached to the occipital bone include:

- 1 rectus capitis posterior minor
- 2 trapezius
- 3 semispinalis capitis
- 4 sternocleidomastoid
- 5 all 4 statements are correct

19. The thyroid gland:

- 1 develops as a downgrowth from the dorsum of the tongue
- 2 develops mainly from branchial arches
- 3 receives blood from branches of the external carotid and subclavian arteries
- 4 is related to the cricoid cartilage
- 5 all 4 statements are correct

20. In front of scalenus anterior lies:

- 1 phrenic nerve
- 2 transverse cervical artery
- 3 suprascapular artery
- 4 second part of subclavian artery
- 5 all 4 statements are correct

21. Surfaces articulating in the wrist (radiocarpal) joint include:

- 1 distal surface of radius
- 2 proximal surface of scaphoid
- 3 proximal surface of lunate
- 4 head of ulna
- 5 all 4 statements are correct

22. Muscles attached to the humerus include:

- 1 brachialis
- 2 brachioradialis
- 3 biceps
- 4 pronator teres
- 5 all 4 statements are correct

contd....

23. Structures attached to the coracoid process of the scapula include:

- 1 long head of biceps brachii muscle
- 2 coracobrachialis muscle
- 3 trapezoid ligament
- 4 pectoralis minor muscle
- 5 all 4 statements are correct

24. The vertebral artery:

- 1 is a branch of the subclavian artery
- 2 gives spinal, meningeal, and cerebellar branches
- 3 grooves the posterior arch of the atlas
- 4 joins its fellow vertebral artery at the lower border of the pons
- 5 all 4 statements are correct

25. Adductors of the shoulder joint include:

- 1 pectoralis major
- 2 teres major
- 3 deltoid
- 4 latissimus dorsi
- 5 all 4 statements are correct

26. Tributaries of the brachial vein/veins include:

- 1 basilic vein
- 2 cephalic vein
- 3 venae comitantes of radial artery
- 4 venae comitantes of ulnar artery
- 5 all 4 statements are correct

27. Among the muscle groups supplied by the posterior divisions of the brachial plexus are:

- 1 extensors of the elbow joint
- 2 extensors of the fingers
- 3 extensors of the wrist joint
- 4 abductors of the fingers
- 5 all 4 statements are correct

28. Axillary nerve:

- 1 is derived from posterior cord
- 2 supplies deltoid
- 3 traverses quadrangular space
- 4 supplies teres major
- 5 all 4 statements are correct

contd....

29. The third ventricle of the brain:

- 1 is continuous with the cerebral aqueduct
- 2 has the thalamus as its lateral wall
- 3 contains the choroid plexus
- 4 has hypothalamic structures in its floor
- 5 all 4 statements are correct

30. The hemiazygos vein drains:

- 1 oesophagus
- 2 pleura
- 3 left intercostal spaces
- 4 spinal cord and spinal meninges
- 5 all 4 statements are correct

31. Concerning the conducting system of the heart:

- 1 the A-V bundle divides into 2 branches
- 2 the Purkinje system is found in both ventricles
- 3 the atrioventricular node is continuous with the A-V bundle
- 4 the sinu-atrial node is not connected with the atrio-ventricular node directly
- 5 all 4 statements are correct

32. Parietal pleura is attached to:

- 1 chest wall
- 2 pericardium
- 3 suprapleural membrane
- 4 diaphragm
- 5 all 4 statements are correct

33. Branches of an intercostal nerve are:

- 1 motor to intercostal muscles
- 2 lateral cutaneous
- 3 collateral
- 4 anterior cutaneous
- 5 all 4 statements are correct

34. The fifth rib:

- 1 is attached to two vertebral bodies
- 2 is attached to one transverse process
- 3 has a costal cartilage which is attached to the sternum
- 4 has a branch of an intercostal nerve along its upper border
- 5 all 4 statements are correct

contd....

35. The left frontal lobe of cerebral cortex includes:

- 1 motor cortex
- 2 premotor cortex
- 3 auditory cortex
- 4 speech centre, usually
- 5 all 4 statements are correct

36. Concerning the bronchi:

- 1 the carina is a feature of the division of the trachea into principal bronchi
- 2 the left principal bronchus is a more direct continuation of the trachea than the right
- 3 the right upper lobe bronchus is given off early in the root of the lung
- 4 bronchial arteries supply the bronchial walls
- 5 all 4 statements are correct

37. Cranial nerve nuclei situated in the grey matter in the floor of the 4th ventricle include:

- 1 XII
- 2 X
- 3 VIII
- 4 IV
- 5 all 4 statements are correct

38. Following a peripheral nerve lesion, the following signs would be found:

- 1 flaccidity of muscles supplied by the nerve
- 2 loss of pain and temperature sensation
- 3 loss of the sense of touch
- 4 no loss of proprioception
- 5 all 4 statements are correct

39. The fornix:

- 1 is essentially an association tract
- 2 ends anteriorly in the mamillary body
- 3 ends posteriorly in the hippocampus
- 4 has the septum pellucidum attached to it
- 5 all 4 statements are correct

40. Ascending spinal tracts include, or are found in, those named:

- 1 fasciculus gracilis
- 2 spinothalamic
- 3 sulcomarginal
- 4 intersegmental (fasciculi proprii)
- 5 all 4 statements are correct

41. The internal capsule includes:

- 1 corticospinal tracts
- 2 corticopontine tracts
- 3 thalamic radiations
- 4 mamillothalamic tract
- 5 all 4 statements are correct

42. Movements of the vertebral column include:

- 1 flexion
- 2 extension
- 3 lateral flexion
- 4 rotation
- 5 all 4 statements are correct

43. Concerning the spinal cord:

- 1 the adult spinal cord ends at the level of lower border of L5
- 2 the filum terminale is the extension of the spinal pia mater below the conus medullaris
- 3 the filum terminale penetrates the spinal dura at S2
- 4 filum terminale attached to dorsum of coccyx
- 5 all 4 statements are correct

44. Suboccipital triangle is bounded by:

- 1 obliquus capitis superior
- 2 obliquus capitis inferior
- 3 rectus capitis posterior major
- 4 rectus capitis posterior minor
- 5 all 4 statements are correct

45. Branches of the abdominal aorta include:

- 1 inferior mesenteric
- 2 middle suprarenal
- 3 iliolumbar
- 4 median sacral
- 5 all 4 statements are correct

46. The ureter:

- 1 has smooth muscle in its walls
- 2 originates from the renal pelvis
- 3 crosses the pelvic brim
- 4 joins the superior surface of the bladder
- 5 all 4 statements are correct

contd....

47. Derivatives of the fascia transversalis include:

- 1 femoral sheath
- 2 internal spermatic fascia
- 3 fascia of quadratus lumborum
- 4 fascia lining abdominal surface of diaphragm
- 5 all 4 statements are correct

48. The anterior relations of the right kidney include:

- 1 the descending part of duodenum
- 2 jejunal coils
- 3 right colic flexure
- 4 the right lobe of the liver
- 5 all 4 statements are correct

49. The trigone of the bladder:

- 1 is the least mobile part of the organ
- 2 has the openings of urethra and both ureters
- 3 is covered by smooth transitional epithelium
- 4 lies immediately anterior to the rectum in the female
- 5 all 4 statements are correct

50. The prostate:

- 1 surrounds the commencement of the urethra in the male
- 2 is situated in the true pelvis
- 3 has a posterior surface related to the rectum
- 4 has a fibrous sheath (capsule)
- 5 all 4 statements are correct

51. The female urethra:

- 1 begins at the bladder neck
- 2 lies in the anterior wall of the vagina
- 3 opens into the vestibule
- 4 is about 10 cm in length
- 5 all 4 statements are correct

52. The vagina:

- 1 has recesses called fornices
- 2 is related to the rectum
- 3 is joined to the cervix uteri
- 4 is related to the urethra
- 5 all 4 statements are correct

contd....

53. The pelvic splanchnic nerves:

- 1 come from the sacral plexus
- 2 supply the bladder
- 3 supply the descending colon
- 4 contain post-ganglionic parasympathetic fibres
- 5 all 4 statements are correct

54. The round ligament of the uterus:

- 1 lies in the inguinal canal
- 2 attaches to the labium majus
- 3 is situated between the layers of the broad ligament
- 4 is accompanied by the genital branch of the genito-femoral nerve
- 5 all 4 statements are correct

55. The spermatic cord contains:

- 1 ductus deferens
- 2 testicular artery
- 3 pampiniform plexus of veins
- 4 lymphatics from testis
- 5 all 4 statements are correct

56. Muscles in the superficial perineal pouch include:

- 1 ischiocavernosus
- 2 bulbospongiosus
- 3 superficial transverse perineal
- 4 external anal sphincter
- 5 all 4 statements are correct

57. The perineal membrane:

- 1 is limited posteriorly at the level of a line joining the ischial tuberosities
- 2 is common to superficial and deep perineal pouches
- 3 has the bulb of the penis on its inferior aspect
- 4 is pierced by the urethra
- 5 all 4 statements are correct

58. Muscles supplied by the obturator nerve include:

- 1 adductor longus
- 2 adductor magnus
- 3 obturator externus
- 4 obturator internus
- 5 all 4 statements are correct

contd....

59. The ductus deferens:

- 1 starts at the epididymis
- 2 passes through the inguinal canal
- 3 descends on the lateral side of the seminal vesicle
- 4 joins the duct of the seminal vesicle to form the ejaculatory duct
- 5 all 4 statements are correct

60. The skin over the femoral triangle is supplied by:

- 1 anterior cutaneous branches of femoral nerve
- 2 lateral cutaneous nerve of thigh
- 3 femoral branch of genitofemoral nerve
- 4 saphenous nerve
- 5 all 4 statements are correct

61. The ischial spine is attached or closely related to:

- 1 sacrospinous ligament
- 2 coccygeus muscle
- 3 internal pudendal vessels
- 4 nerve to obturator internus
- 5 all 4 statements are correct

62. Combinations of muscles with their actions on the hip joint are:

- |   |                              |   |                 |
|---|------------------------------|---|-----------------|
| 1 | gluteus maximus              | - | extension       |
| 2 | gluteus medius               | - | abduction       |
| 3 | gluteus minimus              | - | medial rotation |
| 4 | ilio-psoas                   | - | adduction       |
| 5 | all 4 statements are correct |   |                 |

63. Branches of the posterior tibial artery supply:

- 1 the ankle joint
- 2 the heel
- 3 muscles in the sole
- 4 the toes
- 5 all 4 statements are correct

64. The superficial peroneal nerve:

- 1 supplies peroneus longus
- 2 pierces deep fascia of the lower leg
- 3 supplies dorsal digital branches to both sides of the second toe
- 4 originates as a branch of the common peroneal nerve near the knee
- 5 all 4 statements are correct

contd....

65. Gluteus maximus muscle:

- 1 is attached to the sacrotuberous ligament
- 2 is attached to the posterior part of the ilium
- 3 is supplied by the superior gluteal nerve
- 4 has the inferior gluteal artery lying deep to it
- 5 all 4 statements are correct

66. Derived from entoderm are:

- 1 yolk sac
- 2 allantois
- 3 vitelline duct
- 4 septum transversum
- 5 all 4 statements are correct

67. The umbilical artery:

- 1 is partly obliterated after birth
- 2 arises from the internal iliac artery
- 3 its patent part is the superior vesical artery
- 4 its obliterated part is a fibrous cord in the lateral umbilical peritoneal fold
- 5 all 4 statements are correct

68. The dorsal columns of the spinal cord convey ascending tracts which are:

- 1 proprioceptive pathways
- 2 touch pathways
- 3 pressure pathways
- 4 pain pathways
- 5 all 4 statements are correct

69. Combinations of nerve and muscle are:

- 1 flexor pollicis longus - anterior interosseus nerve
- 2 flexor digitorum superficialis - median nerve
- 3 pronator quadratus - anterior interosseus nerve
- 4 flexor carpi ulnaris - ulnar nerve
- 5 all 4 statements are correct

70. The following are formed from the mesoderm of the embryo:

- 1 bone
- 2 muscle
- 3 nerve cells
- 4 blood vessels
- 5 all 4 statements are correct

contd....

Answer the following questions (71 - 88) according to the following key:

- 1 If A, B, C are correct
- 2 If A, C are correct
- 3 If B, D are correct
- 4 If any other combination (including all four statements), or only one of the statements, is correct
- 5 If none of the four statements is correct

71. The visceral (inferior) surface of the liver is related to:

- A the spleen
- B the duodenum
- C the left kidney
- D right flexure of colon

72. The posterior triangle of the neck:

- A has the trapezius as its postero-lateral border
- B is roofed by the investing layer of the deep cervical fascia
- C has the external jugular vein enter it through its roof
- D contains the external carotid artery

73. The median nerve supplies:

- A flexor pollicis brevis
- B palmar interossei
- C adductor pollicis
- D palmaris longus

74. Concerning the triceps muscle:

- A it has an attachment to the scapula
- B it is supplied by both radial and axillary nerves
- C it is attached to the olecranon
- D the tendon of its long head passes through the shoulder joint

75. Muscles extending the wrist joint:

- A extensor carpi radialis longus
- B extensor carpi ulnaris
- C extensor digitorum
- D brachioradialis

76. Opening into the hiatus semilunaris of the middle meatus are:

- A sphenoid sinus
- B frontal sinus
- C nasolacrimal duct
- D some ethmoidal sinuses

contd....

77. The lingual nerve:

- A is a branch of maxillary nerve
- B supplies sensation to anterior part of tongue
- C supplies the genioglossus muscle
- D is joined by the chorda tympani

78. The lateral pterygoid muscle is inserted into:

- A the neck of the mandible
- B the capsule of the temporomandibular joint
- C the intra-articular disc of the temporomandibular joint
- D the angle of the mandible

79. Concerning the brain:

- A both arachnoid and pia mater are present on the surface of the brain removed from the cranial cavity
- B the cerebellum occupies the posterior cranial fossa
- C the central sulcus runs anteriorly, laterally and inferiorly
- D the temporal lobe consists of 3 vertically disposed gyri

80. The following muscles are supplied by the dorsal rami of spinal nerves:

- A levator scapulae
- B splenius capitis
- C rhomboid minor
- D semispinalis capitis

81. Related to the visceral surface of the spleen will be found:

- A stomach
- B left kidney
- C colon
- D diaphragm

82. Accompanying the aorta through the diaphragm may be the following structures:

- A the left vagus nerve
- B the thoracic duct
- C the left phrenic nerve
- D the azygos vein

83. Bounding the ischiorectal fossa are:

- A the obturator internus muscle
- B the levator ani
- C the sacrotuberous ligament
- D quadratus femoris

contd....

84. The fibular collateral (lateral) ligament of the knee joint:

- A is attached to the head of the fibula
- B is attached to the lateral meniscus
- C splits the tendon of biceps femoris
- D tightens when the knee is fully flexed

85. Relations of the femoral canal include:

- A iliopsoas muscle
- B femoral vein
- C femoral artery
- D inguinal ligament

86. The corpus callosum:

- A roofs the lateral ventricles
- B consists of association fibres
- C consists of commissural fibres
- D is the only cerebral commissure

87. The 'spring' ligament:

- A is the plantar calcaneo-navicular ligament
- B is the plantar calcaneo-cuboid ligament
- C maintains the medial longitudinal arch of the foot
- D maintains the lateral longitudinal arch of the foot

88. In the nerve supply of the scalp, the nerves mentioned arise from:

- |   |                    |   |                 |
|---|--------------------|---|-----------------|
| A | zygomaticotemporal | - | mandibular      |
| B | supraorbital       | - | ophthalmic      |
| C | greater occipital  | - | cervical plexus |
| D | auriculotemporal   | - | mandibular      |

contd....

Answer the following questions (89 - 90) according to the following key:

- 1 If statements A & B are both true and their relation IS causal
- 2 If statements A & B are both true but their relation is NOT causal
- 3 If statement A is true and B is false
- 4 If statement A is false and B is true
- 5 If statement A is false and B is also false

89. A. Muscles of expression are supplied by the facial nerve

BECAUSE

B. their mesoderm migrated from third branchial arch.

90. A. Lumbar spinal segments are represented in the sciatic nerve

BECAUSE

B. the lumbosacral trunk arises from lumbar spinal nerves.

SAMPLE EXAMINATION PAPER :

ANATOMY ESSAYS

UNIVERSITY EXAMINATIONS : NOVEMBER 1983

A N A T O M Y : FIRST PAPER

(2nd year MB ChB)

---

Time: THREE hours

ALL questions to be attempted

CERTIFICATION multiple choice questions to be answered on the sheet provided  
QUESTIONS 1, 2, & 3 to be answered in SEPARATE BOOKS

CERTIFICATION MULTIPLE CHOICE QUESTIONNAIRE (see attached sheets).

(The question and the answer sheet will be collected at the end of 60 minutes).

N.B. The maximum possible mark derived from Certification and Grading is 100

The maximum mark for Anatomy Essay questions in Paper 1 and Paper 2

is 100. Question 4 will be in Paper 2.

1. Describe the course and distribution of the left vagus nerve, from the point where it leaves the brain stem. [30]
2. Describe the course, distribution and anastomotic connections of the femoral artery and its branches in the thigh. [20]
3. Describe the diaphragm (including its respiratory function), and give an account of its embryology. [30]

SAMPLE EXAMINATION PAPER

IN DESCRIPTIVE ASTRONOMY

UNIVERSITY OF CAPE TOWN  
DEPARTMENT OF ASTRONOMY

ASTRONOMY (a)

FINAL EXAMINATION 1983 OCTOBER 17

Time allowed: 3 hours

Total marks: 140

Please check that your copy of this paper has a total of 9 printed pages.

**ENTER YOUR NAME:** .....

SECTION A  
(60 marks)

Constants:

$G = 6,67 \times 10^{-11} \text{ Nm}^2 \text{ kg}^{-2}$   
 $1 \text{ solar mass} = 2 \times 10^{30} \text{ kg}$   
 $\text{Hubble constant } H = 55 \text{ km s}^{-1} \text{ Mpc}^{-1}$   
 $1 \text{ pc} = 3,08 \times 10^{13} \text{ km} = 3,26 \text{ light years}$   
 $c = 3 \times 10^8 \text{ ms}^{-1}$

Attempt ALL questions in this section

Fill in answers in the spaces provided

This section counts 3/7 of the marks for the whole paper. It is divided into 60 marks so that you can budget on just over one minute per mark and just over an hour for the whole section. Individual marks per question are indicated in parentheses in the right hand margin.

1. Describe, very briefly, how the apparent size (angular diameter) of the Sun's disk compares with that of the Moon. (2)

ENTER NAME: .....

2.

Astronomy (a)  
continued:

October 1983

For the next 6 questions we will consider a hypothetical planet and moon system with parameters as follows:

	<u>Mass</u>		<u>Radius</u>
Planet	$1,5 \times 10^{26}$ kg		$10\ 000\ \text{km} = 10^7\ \text{m}$
Moon	$1,5 \times 10^{23}$ kg		$1\ 000\ \text{km} = 10^6\ \text{m}$

Distance between centre of Planet and centre of Moon is  $20\ 000\ \text{km} = 2 \times 10^7\ \text{m}$

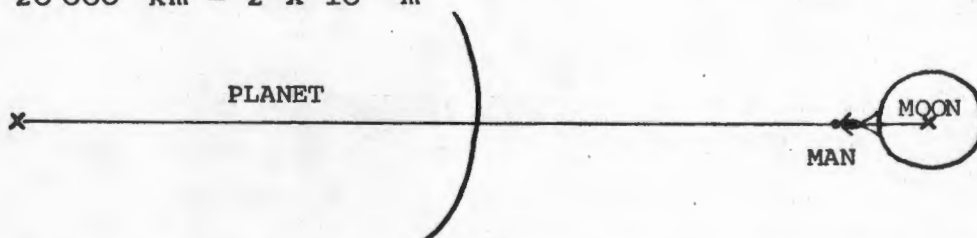

2. How far from the centre of the Planet does the centre of mass of the Planet/Moon system lie? (3)

3. How big is the gravitational force of attraction between the Planet and the Moon? (4)

4. Consider a man of mass 100 kg standing on the Moon at the point closest to the planet (see diagram). What is the gravitational force exerted on the man by the Moon? (4)

ENTER NAME: .....

3.

Astronomy (a)  
continued:

October 1983

---

Working space for Question 4

5. How would you say that the answer to the previous question compares with the gravitational force (i.e. weight) of the man had he been on the surface of the Earth? (2)
6. Now calculate the gravitational force exerted on the man by the Planet. (The answer might surprise you). (4)
7. What can you deduce from the answers to Questions 4 and 6 - both in terms of the man and perhaps the Moon as well? (6)

4.

Astronomy (a)  
continued:

October 1983

---

Space for Question 7

8. Briefly describe why the Royal Observatory at the Cape of Good Hope was founded. (5)

[YOU ARE NOW HALF WAY THROUGH SECTION A]

Page 5/Question 9/.....

5.

Astronomy (a)  
continued:

October 1983

---

9. If Star A has apparent magnitude 2.5 and Star B apparent magnitude 5.0, what is the ratio of their apparent luminosities? (3)

10. A cluster of stars contains a main sequence star with identical spectral type to that of the Sun. This star has apparent magnitude 15 whilst our Sun has absolute magnitude 5. What is the distance to the cluster? (3)

12. Describe some of the objects you have seen on the Palomar and UK Sky Survey photographs. (5)

6.

Astronomy (a)  
continued:

October 1983

---

13. Why is it appropriate for the perfect gas law to be applied to the Sun's interior, even though the density is so high? (2)

14. If the Sun is losing mass at the rate of  $4 \times 10^9$  kg per second (as hydrogen fuses into helium), what is its energy output per second? (3)

15. Make a rough sketch of what you think an Sc galaxy looks like. (2)

ENTER NAME: .....

7.

Astronomy (a)  
continued:

October 1983

---

16. The oxygen emission line, normally at  $5007\text{\AA}$  wavelength is redshifted to  $5200\text{\AA}$  in the spectrum of a distant galaxy. What is the implied velocity of recession? (3)

17. Assuming Hubble expansion, what is the implied distance of the galaxy in the previous question? (2)

18. If the Hubble constant was found to be  $110 \text{ km s}^{-1} \text{ Mpc}^{-1}$  instead of  $55 \text{ km s}^{-1} \text{ Mpc}^{-1}$ , what consequences would it have cosmologically? (4)

8.

Astronomy (a)  
continued:

October 1983

---

19. If the mass and radius of the Earth were both doubled, by what factor would its surface gravity change? (2)

20. Which planet has the greatest relative concentration of mass towards its centre? (1)

- END OF SECTION A -

ENTER NAME: .....

9.

Astronomy (a)  
continued:

October 1983

---

SECTION B  
(80 marks)

Attempt any FOUR of the following essay questions

1. Using a sequence of diagrams, with explanatory text, demonstrate that you understand where the Earth is located relative to the surrounding universe, and what the main constituents of this universe are. (An exact replica of the passageway board sequence is not expected).
2. Describe in some detail how (a) the Sun; (b) the Moon and (c) the planets appear to move against the celestial sphere.
3. Write an account of instruments and observatories in modern astronomy.
4. What is a star? Why is its surface hot? How is it formed and what governs its rate of evolution? What is its future?
5. Write an essay on binary stars, including those with very small separations and resulting effects.
6. What is the evidence for a "big bang" origin to our universe? What can we say of its geometry and future evolution.
7. Describe the surface of Mars.
8. Write on the possibility of the existence of extraterrestrial civilisations and communication and contact with such.

THE FULL ASTRONOMICAL SPATIAL TEST

within which is incorporated

THE NOVICE ASTRONOMICAL SPATIAL TEST

CONSISTING OF QUESTIONS



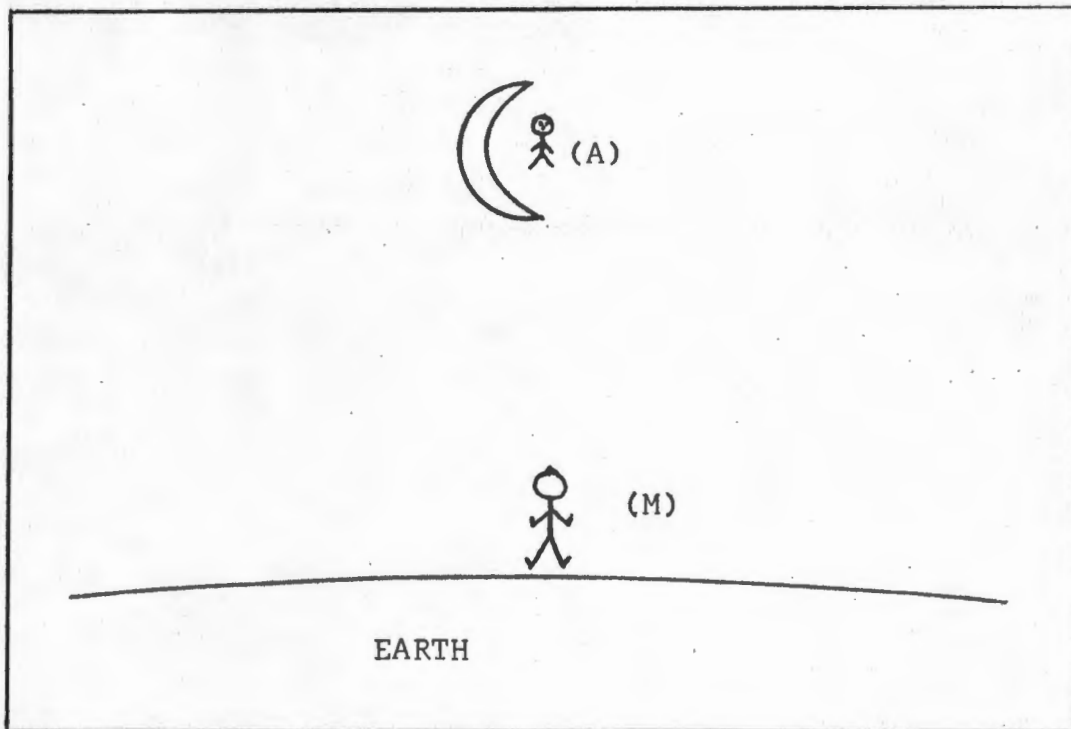

1, 2, 3, 6, 8, 11, 12 and 17.

THE FULL ASTRONOMICAL SPATIAL TEST

- (1) The following diagram shows a man (M) standing on the Earth, looking at the crescent Moon. An astronaut (A) is standing on the Moon looking back towards the Earth.



What is the phase of the Earth as seen by the astronaut (A)? Circle the one best answer:-

- (1) A crescent Earth 
- (2) A half Earth 
- (3) A gibbous Earth 
- (4) A full Earth 
- (5) A new Earth 
- (6) I cannot visualize the answer.

(2) Circle the one best answer:-

Viewed from the North Pole, the Earth

(1) rotates anticlockwise on its axis and revolves clockwise around the Sun;



(2) rotates anticlockwise on its axis and revolves anticlockwise around the Sun;



(3) rotates clockwise on its axis and revolves anticlockwise around the Sun;



(4) rotates clockwise on its axis and revolves clockwise around the Sun.



(5) I am unable to work out the answer.

(3) Study the following diagram in which are given positions of the Sun, Mars, and Mars' two moons - Phobos and Deimos. The plane of Mars' orbit is in the plane of the page.

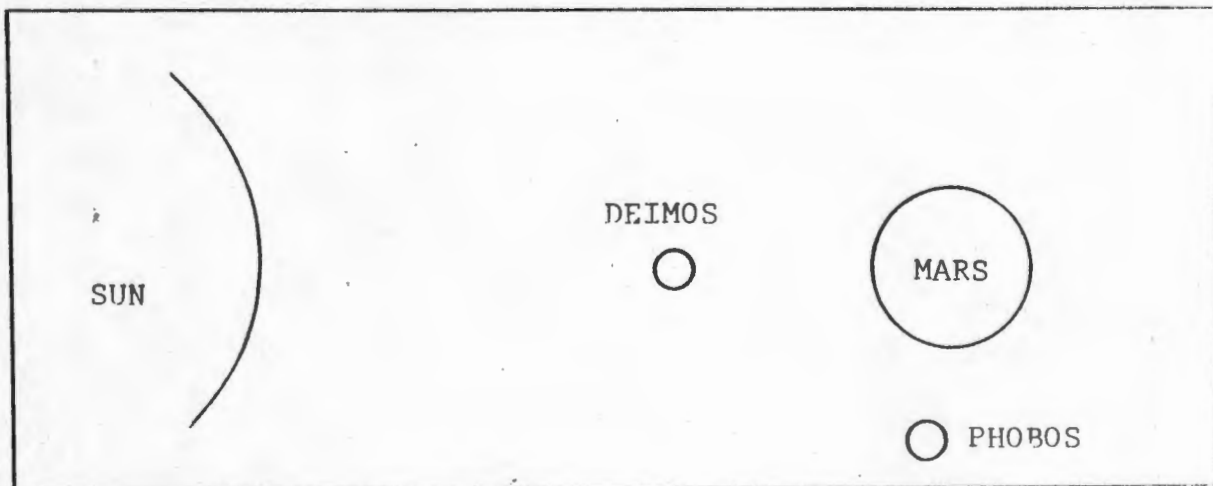

Circle the one best answer:-

The phase of Phobos, as viewed from Deimos, is

(1) crescent

(2) half

(3) gibbous

(4) full

(5) new

(6) I am unable to visualize the answer.

- (4) Sirius A is a much more massive star than its companion Sirius B. Both stars constitute a moving binary system. In the diagrams below, the dotted line represents the movement of the centre of gravity of this binary system across the page from left to right. The continuous line represents the apparent path in the sky of Sirius A, and the broken line represents the apparent path of Sirius B. Which of the following four diagrams most accurately depicts the apparent paths in the sky of Sirius A and Sirius B compared to each other? Circle the one best answer.

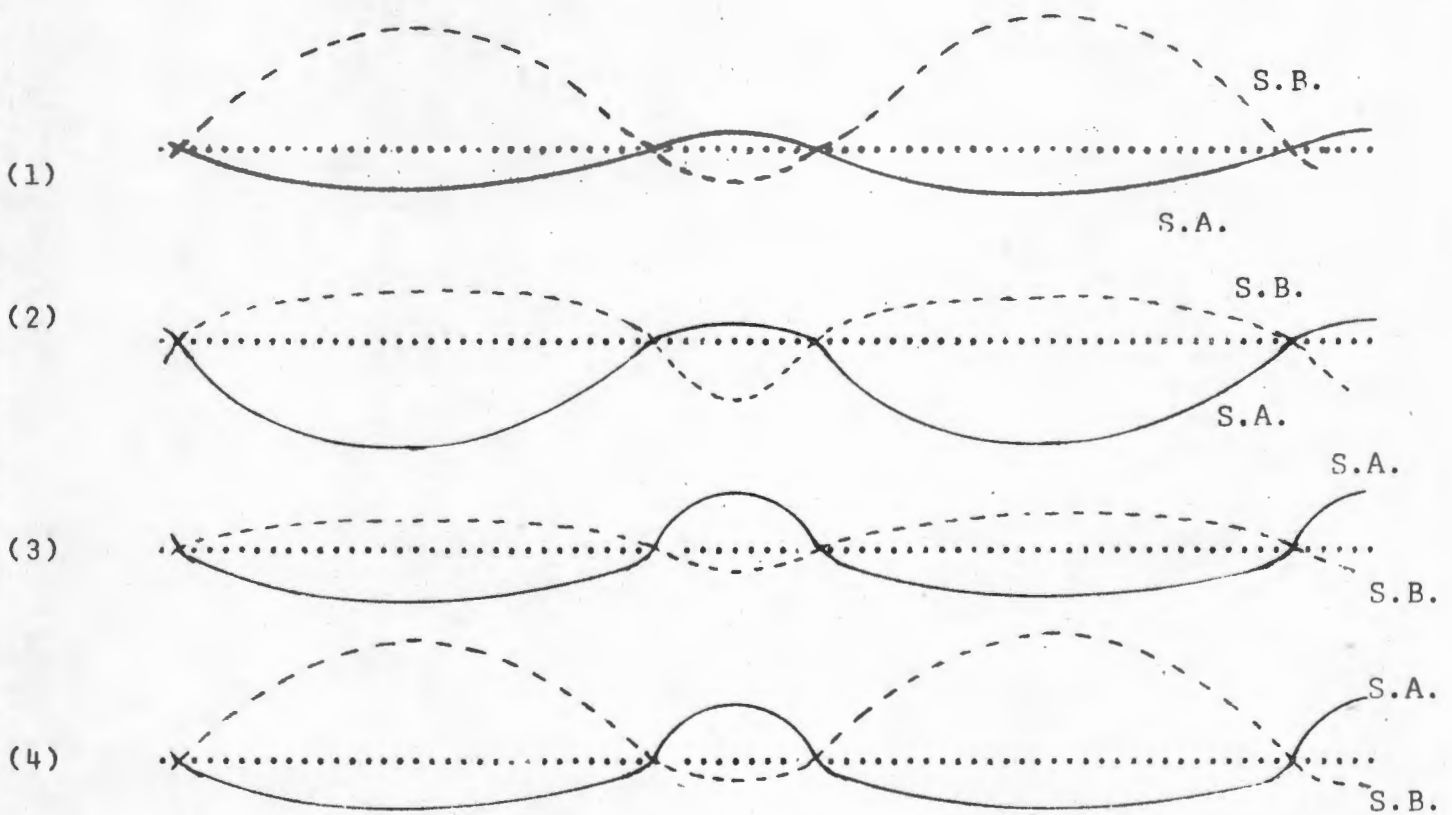

- (5) I am unable to work out the answer.

(5)

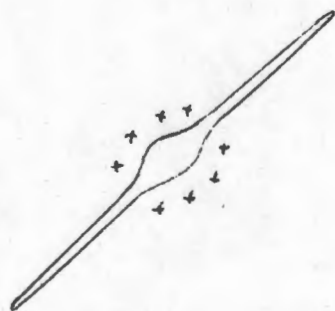

← . P

If the Andromeda Nebula could be viewed side-on, its shape would appear somewhat like that depicted above. The little crosses around the core of the galaxy represent globular clusters.

Suppose that, instead, the frame of reference of the observer could be moved from above the page to the point P, looking at the plane of the Andromeda galaxy itself. What do you think the observer would see? Sketch the new appearance of the nebula in the space below, as the observer would see it from point P.

(6)

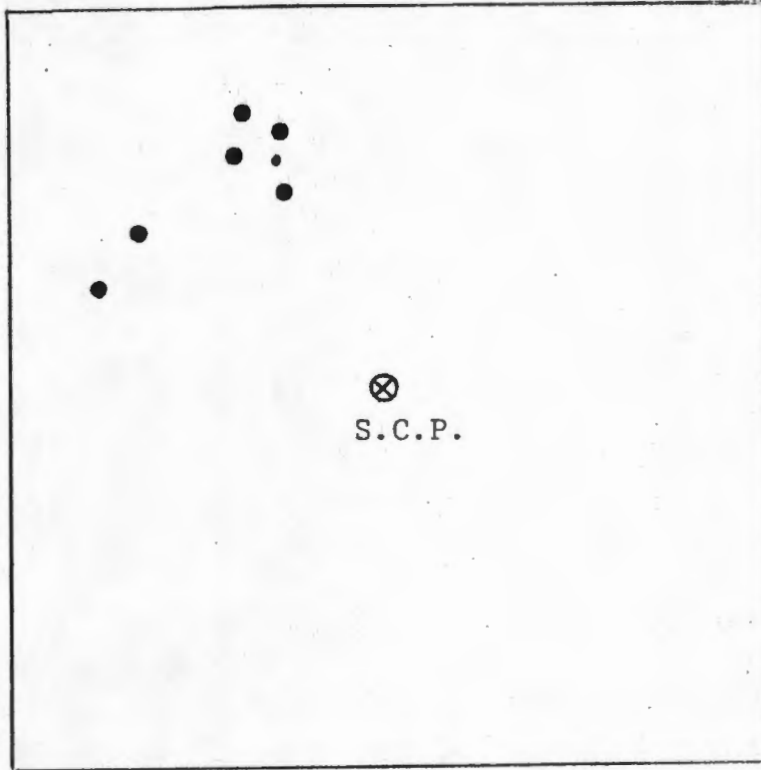

DIAGRAM A

The above DIAGRAM A depicts the position of the Pointers and the Southern Cross relative to the South Celestial Pole at 18h30 on July 30. Twelve hours later, at 06h30 on July 31, the position of the Pointers relative to the South Celestial Pole is depicted in DIAGRAM B. Draw in as accurately as possible on DIAGRAM B below, the new positions of the five main stars of the Southern Cross as they would appear at 06h30 on July 31.

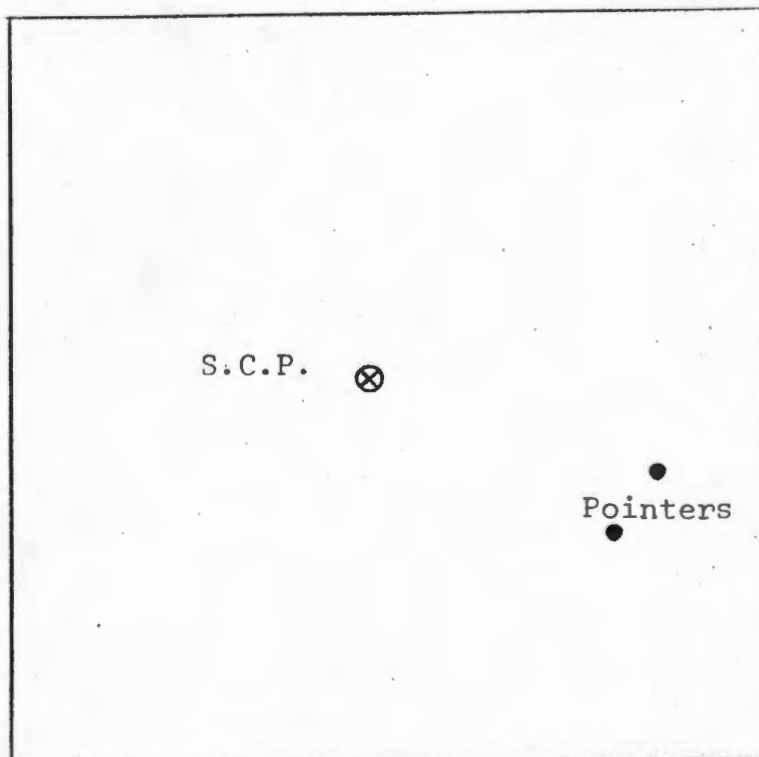
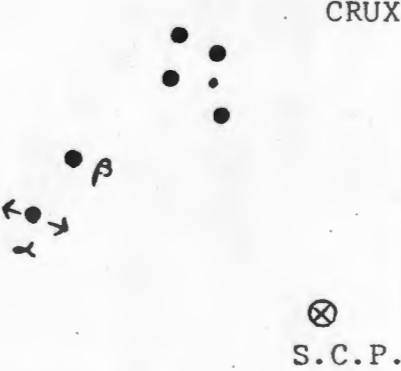
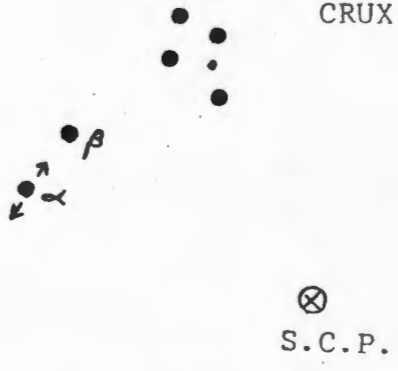
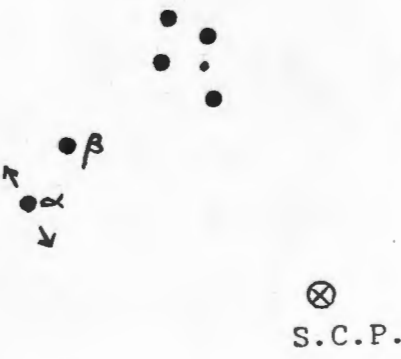
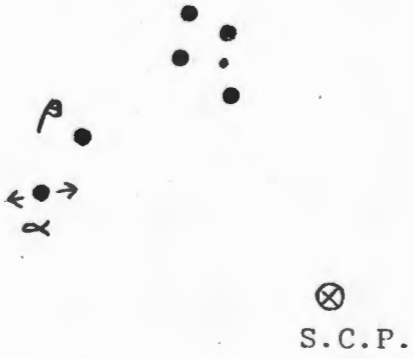

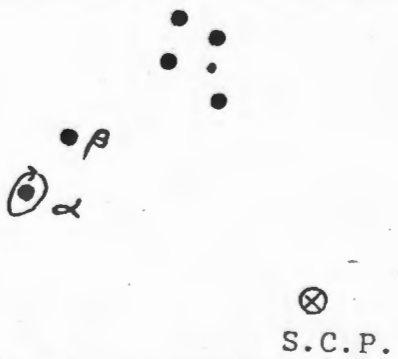

DIAGRAM B

(7) The parallax of  $\alpha$ -Centauri is 0,75" of arc. Which of the following six diagrams most accurately depicts the direction of its apparent movement relative to  $\beta$ -Centauri during the course of one year? (Circle the one best answer).

 <p>(1) Oscillating in a North-South direction.</p>	 <p>(2) Oscillating in an East-West direction.</p>
 <p>(3) Oscillating in a direction <math>23\frac{1}{2}^\circ</math> West of North.</p>	 <p>(4) Oscillating in a direction <math>23\frac{1}{2}^\circ</math> East of North.</p>
 <p>(5) Following an anticlockwise elliptical path.</p>	 <p>(6) Following a clockwise elliptical path.</p>

- (8) The axis of Uranus is tilted  $98^\circ$  relative to a normal to its orbital plane, compared with an inclination of  $23\frac{1}{2}^\circ$  for the axis of the Earth.

On the diagram below draw in the axes of both the Earth and Uranus to illustrate their relative inclinations:-

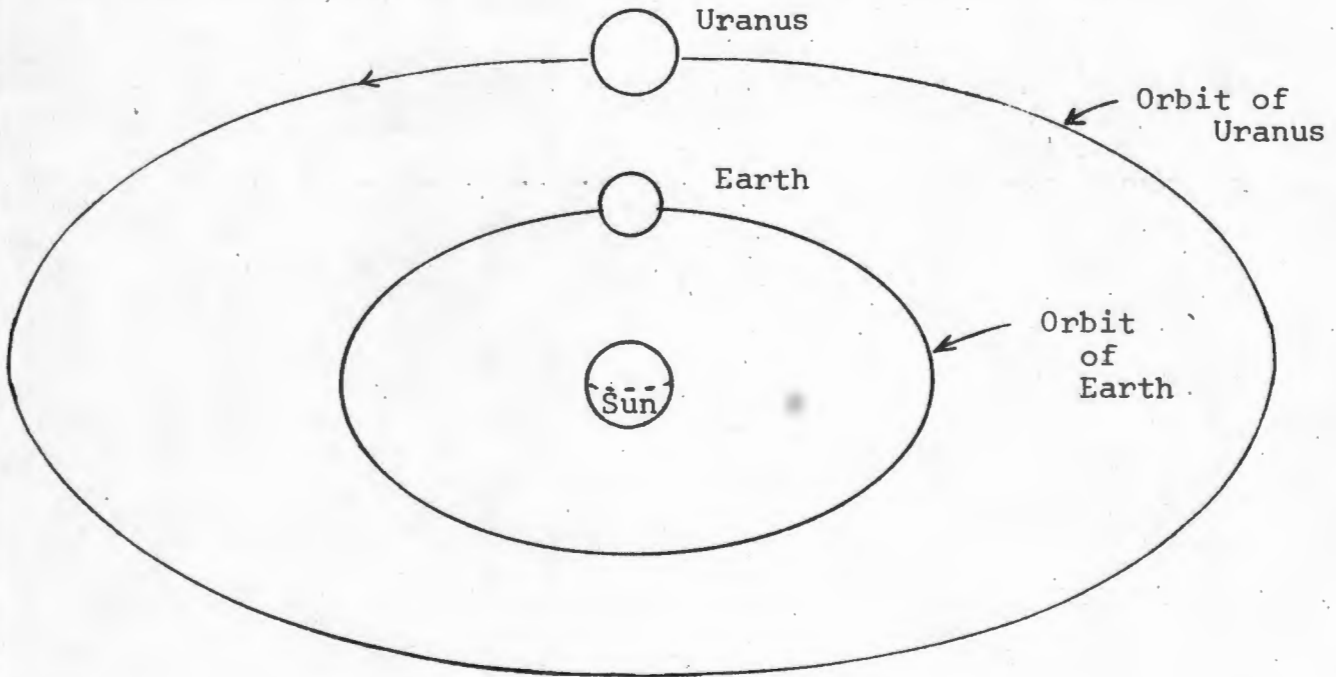

- (9) The two graphs below show plots of the positions of the galactic and globular clusters of galaxy X as seen from star Y inside galaxy X.

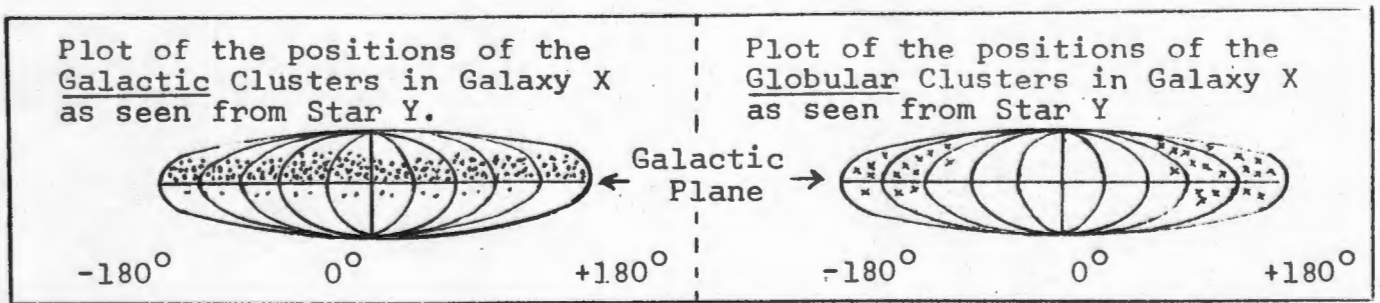

What can you conclude about

- (i) The position of Star Y relative to the plane of Galaxy X? .....
- (ii) The position of Star Y relative to the centre of galaxy X? .....

(10) The accompanying diagram depicts the apparent orbit of the close binary Star Xi Cephei.

Draw on this diagram the position of the major axis of the binary system.

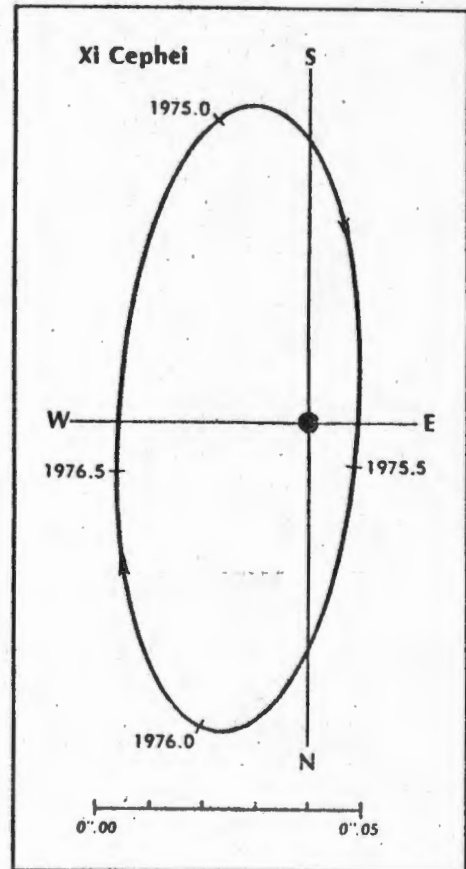

The apparent orbit of Xi Cephei.

(11) The following diagram shows the retrograde loops of Mars, Jupiter and Saturn during 1979-80.

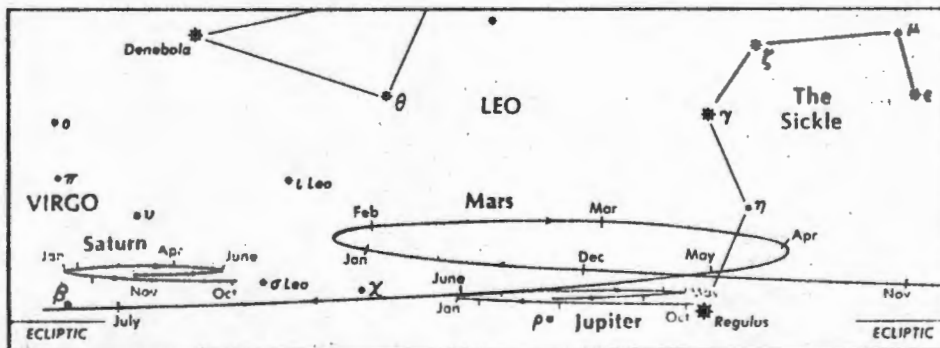

- (1) Briefly explain why the loops in the sky do not appear as straight lines .....
- (2) Briefly explain why the loop of Mars is the biggest. (Use sketches if necessary).

- (12) Mercury rotates on its own axis in 59 days and revolves around the Sun in 88 days. The diagram below represents the orbit of Mercury in the plane of the page, with crater "C" on Mercury directly facing the Sun.

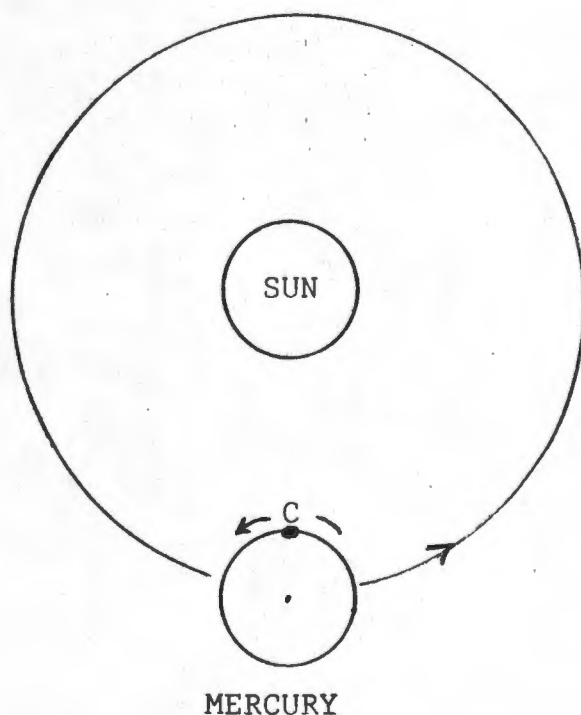

If the planet now continues to revolve around the Sun from the position given, draw in on the above diagram a circle to show

- (i) the position of Mercury after 22 days, with the new position of crater C clearly marked;
  - (ii) the position of Mercury after 59 days, with the new position of crater C clearly labelled.
- Label your answers (i) and (ii).

QUESTIONS 13, 14 AND 15 REFER TO THE FOLLOWING DIAGRAM OF THE ORBITS OF THE COMPONENTS X AND Y OF A DOUBLE STAR

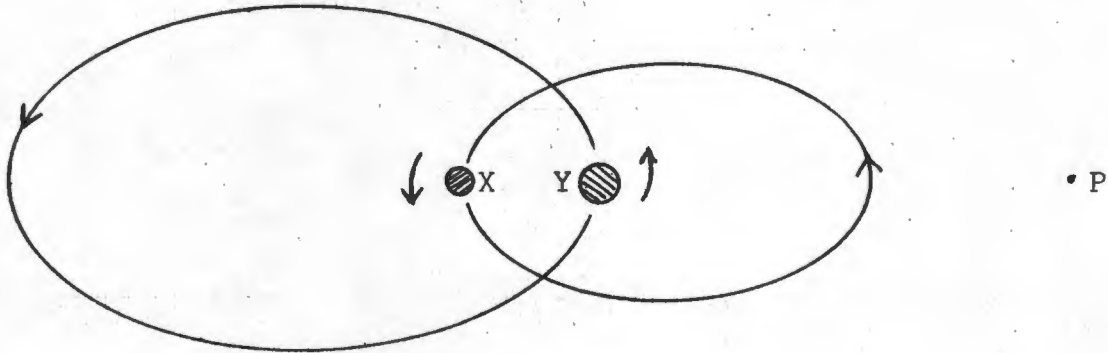

(13) Circle the one best response:-

With regard to the relative masses of stars X and Y in the above diagram:-

- (1) Star X is definitely more massive than Star Y.
- (2) Star Y is definitely more massive than Star X.
- (3) It is possible that both Star X and Star Y have equal masses.
- (4) Star X is losing mass more rapidly than Star Y.
- (5) Star Y is losing mass more rapidly than Star X.

(14) Circle the one best response:-

Viewed from the right, below the distant point P on the above diagram, the shapes of the orbits of X and Y will appear as follows:-

- A. Depending on the position of distant point P, the orbit of X may appear circular while the orbit of Y will appear elliptical.
- B. Depending on the position of distant point P, the orbit of Y may appear circular while the orbit of X will appear elliptical.
- C. Depending on the position below distant point P, either both orbits will appear circular, or both orbits will appear elliptical.
- D. /..... p.t.o.

- D. The orbits of both X and Y will usually appear circular.
- E. The orbits of both X and Y will always appear elliptical.
- F. I am unable to visualize the answer.

(15) Given that C is the centre of gravity of the binary system, then, when Star Y is at position Y in its orbit, Star X will be at position

- (1) 1  
 (2) 2  
 (3) 3  
 (4) 4  
 (5) 5

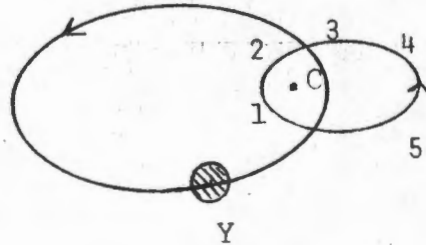

(Circle the one best response).

(16) Explain, with diagrams, how it is possible for an Earth-bound observer to see up to 57% of the Moon's surface when the Moon always keeps the same face towards Earth.

(17) Under what circumstances could a camera, photographing the surface of a planet, produce the following sequence of phases diminishing in size with time?

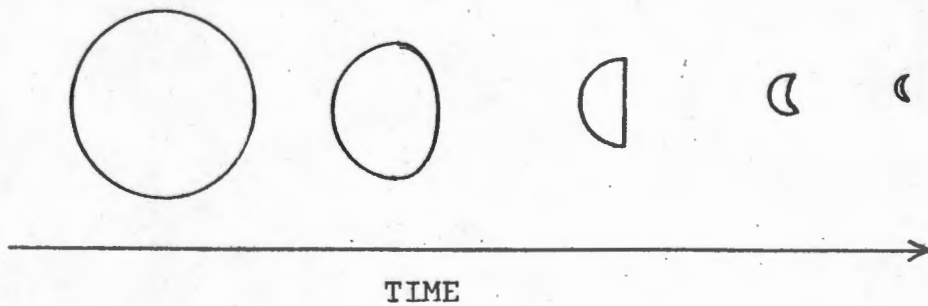

ANSWER: .....

.....

(Be careful; the correct answer is unusual, and not immediately obvious at first glance).

(18) THIS LAST QUESTION IS OPTIONAL.

The light curve of a variable star is a record of how its observed brightness changes over a period of time. On the next pages are the light curves of variable stars (1) to (6). Next to each light curve you are required to write one of the letters A, B, C, D, E, F or G which you think best explains the curve, given the following possible alternative explanations:-

- A. This light curve indicates an eruptive variable star such as a dwarf nova.
- B. This light curve is that of a Cepheid variable star.
- C. This light curve indicates an elliptical orbit with two stars of unequal luminosity revolving around a common centre of gravity, and partially eclipsing each other.
- D. This light curve indicates an elliptical orbit with two stars of unequal luminosity revolving around a common centre of gravity, and undergoing total and annular eclipses.
- E. This light curve indicates two partially eclipsing stars of unequal luminosity revolving around a common centre of gravity; the orbit is circular rather than elliptical.
- F. This light curve indicates two partially eclipsing stars of unequal luminosity revolving around a common centre of gravity, but so close to each other that the powerful gravitational and tidal forces generated deform them into ellipsoids; the orbit is circular rather than elliptical.
- G. This light curve indicates two partially eclipsing stars of similar size and surface brightness revolving around a common centre of gravity, but so close to each other that the powerful gravitational and tidal forces generated deform them into ellipsoids; the orbit is circular rather than elliptical.

ANSWERS:

Write A, B, C, D, E, F or G in each of the boxes below.

(1)

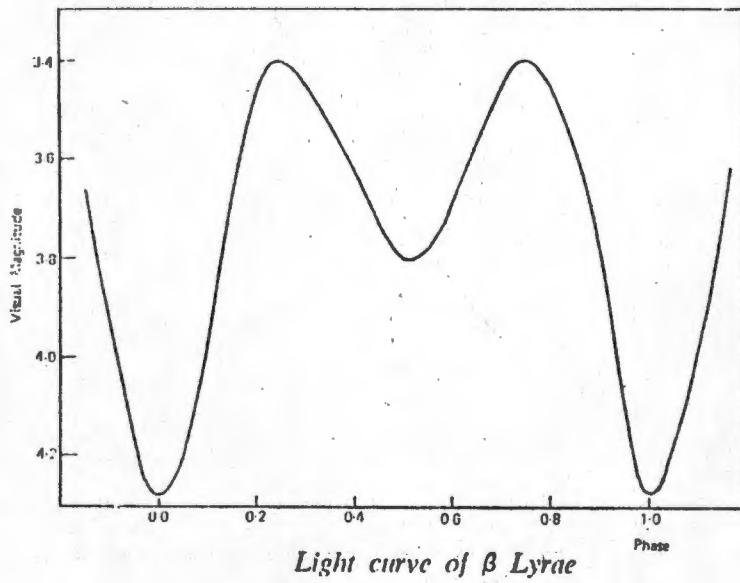

ANSWER:

(2)

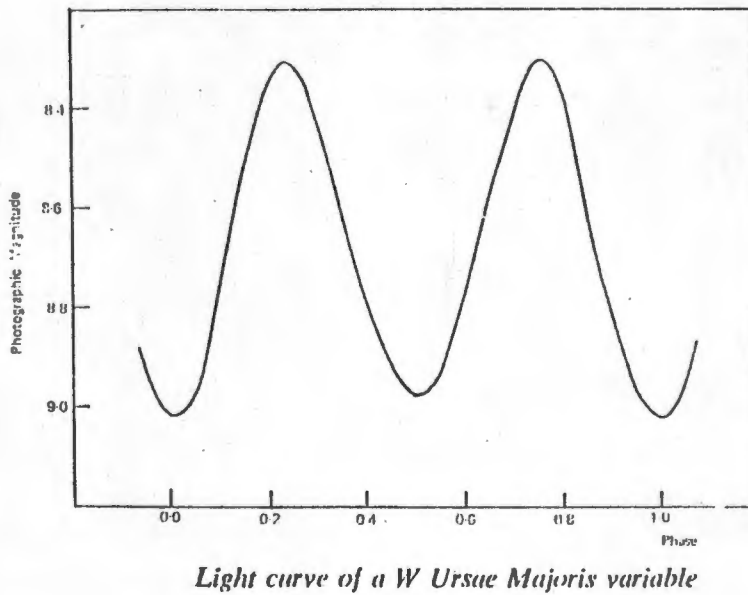

ANSWER:

(3)

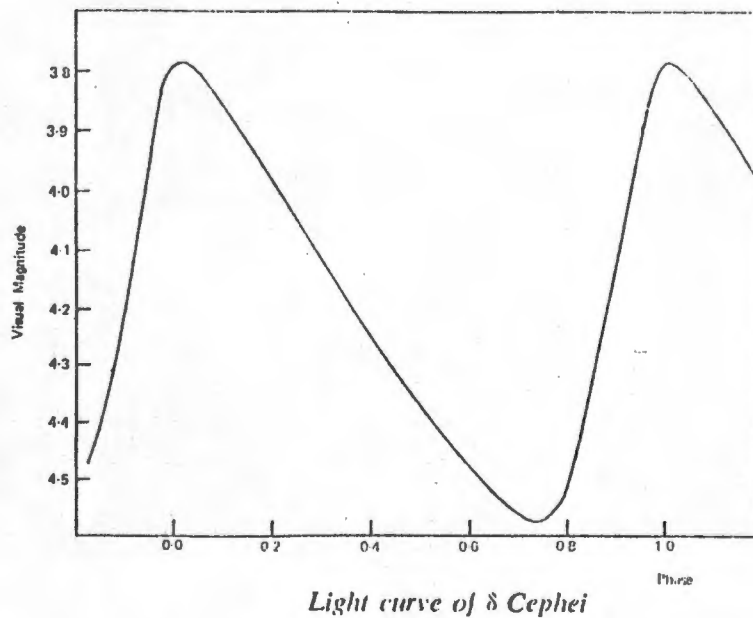

ANSWER:

(4)

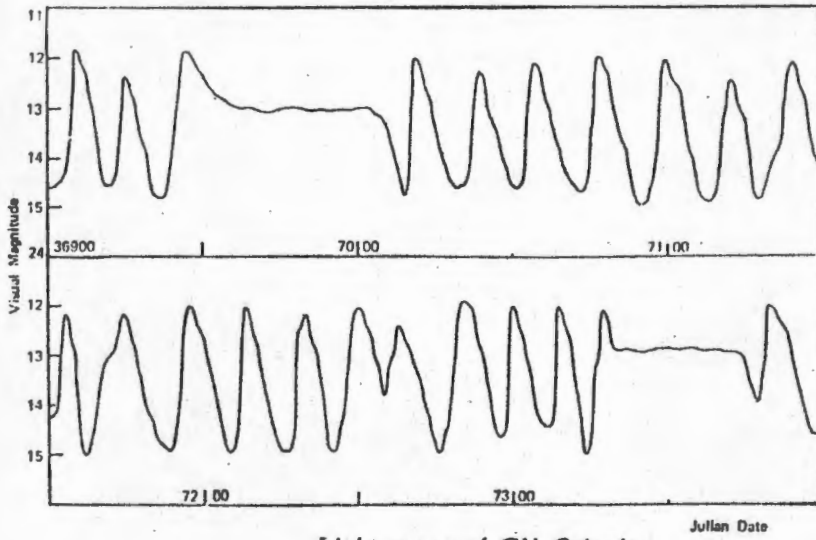

Light curve of CN Orionis

ANSWER:



(5)

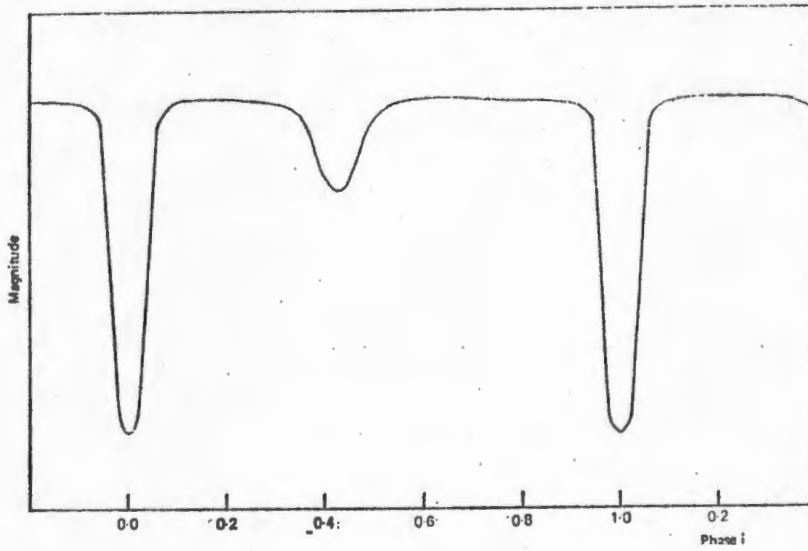

ANSWER:



(6)

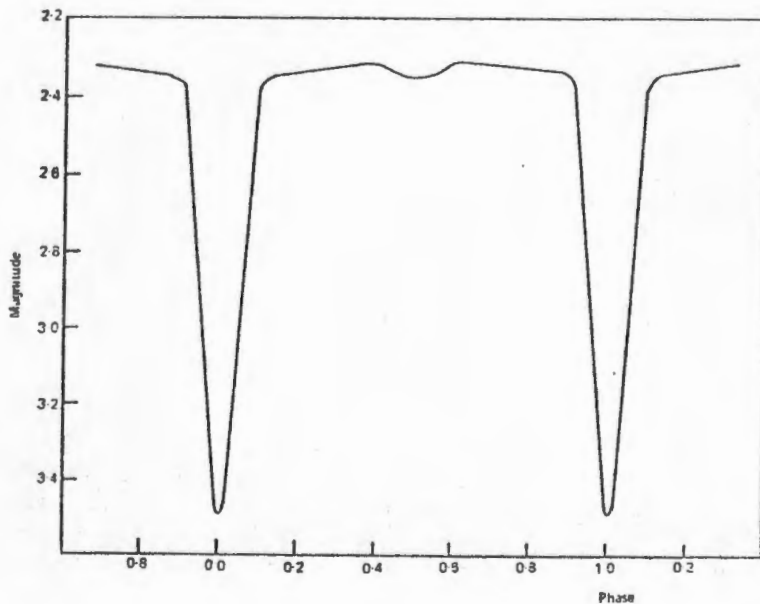

ANSWER:



SAMPLE EXAMINATION PAPER

IN ENGINEERING DRAWING

UNIVERSITY OF CAPE TOWN  
DEPARTMENT OF MECHANICAL ENGINEERING

JUNE 1983

B.Sc. in Mechanical Engineering

Time: THREE Hours

Note:

1. Write your name and desk number on all four worksheets
2. Answer ALL FOUR Questions
3. Credit will only be given for solutions where the construction or method is clearly shown. Presentation is therefore important.
4. All orthographic projections are in third angle.
5. ALL WORKSHEETS, whether attempted or not, must be handed in at the end of the examination period.
6. Remove any masking tape or staples from the worksheet and see that the sheets are arranged in the order as presented.
7. New sheets will only be available in exchange for spoilt sheets.

**Given:** The side view and the incomplete top view of an object one half of which is a right hexagonal pyramid the other a right cone.  
**Required:** Draw a sectional front view on AB and complete the top view by drawing a sectional top view on CD. Project the true shape of the section. As the section is symmetrical about a centre line, only one half need be drawn. Presentation is important in this drawing.

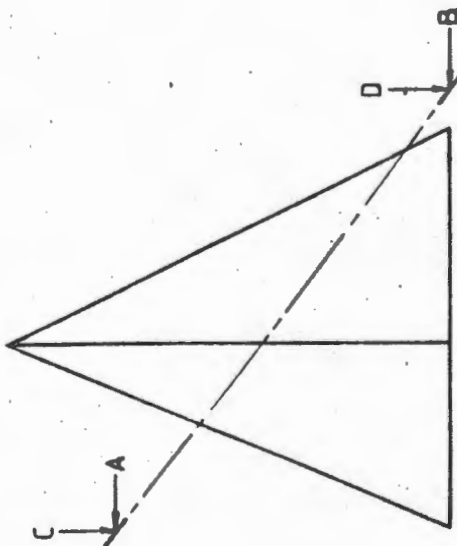
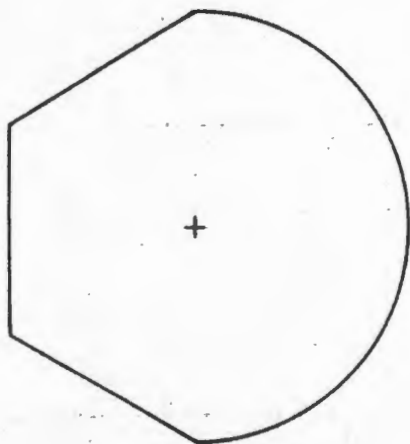

WORK SHEET	Question ONE (30 Marks)	SCALE	1 : 1	ESTIMATED TIME	ACTUAL TIME	INITIALS	SURNAME	DESK NO	MARKS
		DATE							
EXERCISES IN ENGINEERING GRAPHICS AND DESIGN									

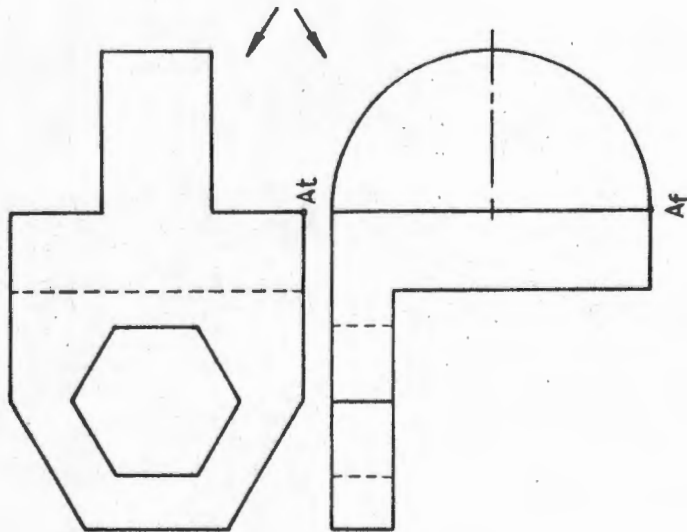

+ A0

+ A1

Given: The top and front views of an object.  
 Required: In the space provided draw two pictorial views of the object, one in isometric projection the other an oblique view in cabinet projection. Hidden detail must not be shown.

WORK SHEET	Question Two (20 Marks)	SCALE 1 : 1	ESTIMATED TIME Minutes	ACTUAL TIME Minutes	INITIALS	SURNAME	DESK NO	MARKS
		DATE						
EXERCISES IN ENGINEERING GRAPHICS AND DESIGN								

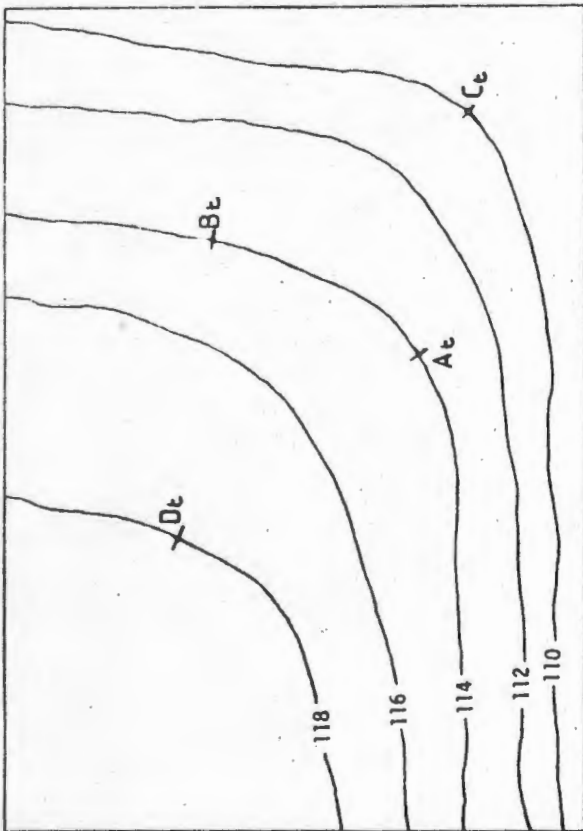

**Given:** A section of a contour map showing points A, B and C where a mining company in prospecting an ore seam drilled three vertical holes. From the ground surface, the ore seam was found 20m below A, 11m below B and 20m below C. Point D is the entrance to an existing vertical shaft 20m deep.

**Required:** Find the strike and dip of the seam. It is planned to build an exploration tunnel from the existing mine shaft at D to the bottom of the hole at C. The centre line of the tunnel is to lie on the surface of the ore seam. Find the depth from the surface at D from which the exploration tunnel should be started as well as the slope of the tunnel. All points and construction must be clearly marked.

Answers STRIKE  
DIP  
DEPTH  
SLOPE

WORK SHEET	Question THREE (25 Marks)	SCALE 1 : 500	ESTIMATED TIME	ACTUAL TIME	INITIALS	SURNAME	DESK NO	MARKS
		DATE						
EXERCISES IN ENGINEERING GRAPHICS AND DESIGN								

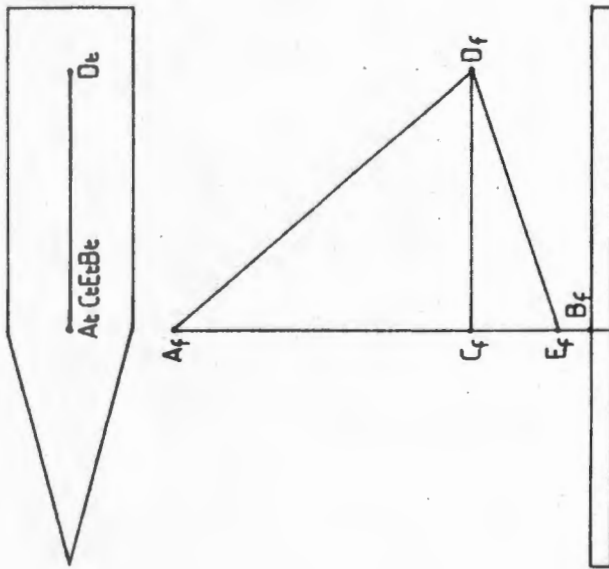

+B<sub>t</sub>

+B<sub>f</sub>

HRP

FRP

**Given:** A windsurfer is shown in schematic form above. The sail can be considered to be a flat plane. The windsurfer is seen by an observer to be sailing in a direction S45°W with the mast making an angle of 50° to the water. The bearing of the mast in the top view is 415°E. The boom (line CD) is parallel to the water and on the south-east side of the board.

**Required:** In the space provided draw the top and front views of the windsurfer as seen by the observer. Use the same scale used in the schematic drawing. Find the true angle of the sail to the water. Label all points and construction.

**Answer:** TRUE ANGLE OF SAIL TO WATER =

WORK SHEET	Question FOUR (25 Marks)	ESTIMATED TIME		ACTUAL TIME		INITIALS	SURNAME	DESK NO	MARKS
		Minutes	Minutes	Minutes	Minutes				
		DATE							
EXERCISES IN ENGINEERING GRAPHICS AND DESIGN									

APPENDIX K

SKETCHING ERRORS MADE BY  
STUDENTS, TOGETHER WITH  
THEIR COMMENTS AND  
"EXPLANATIONS"



## APPENDIX K

GROSS ERRORS IN SKETCHES MADE BY STUDENTS, TOGETHER WITH THEIR COMMENTS  
AND "EXPLANATIONS" (TWO PENALTY MARKS WERE AWARDED FOR EACH GROSS ERROR).(a) Spatial Synthesis Test

Students in 1980 were required to deduce and draw and name the shapes of common objects, given sections of them through the sagittal, coronal and horizontal planes.

Students in 1981 were required to do the same given north-south and east-west vertical sections and the horizontal section.

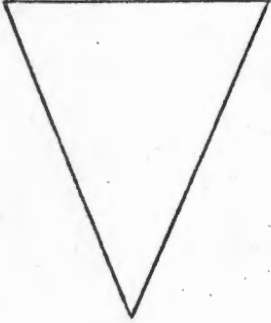
(i) Cone

	NORTH-SOUTH VERTICAL SECTION	EAST-WEST VERTICAL SECTION	HORIZONTAL SECTION	ANSWER
1				

A champion chess player with 3D visual problems, Student No. 1 pondered the problem for several minutes; made the following tentative, incorrect sketch; and finally named the object a "cylinder".

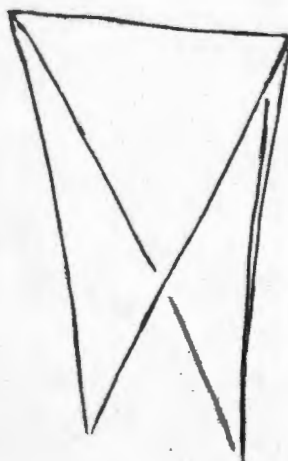

*cylinder.*

Apparently he could not appreciate that the two triangular sections shared a common vertical axis instead of a common base line.

In 1981 seven students drew diagrams of the cone which were considered to be grossly defective. Six of these students revealed an inability to visualize a continuously curved surface given only straight lines in its section:-



Triangular Hook

Student No. 5



circle-based inverted triangle

Student No. 6



Isosceles  $\Delta$  with a round stalk

Student No. 7



Student No.8



Triangle with semicircular base.

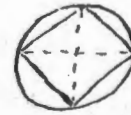

Student No.9



Student No. 11

Student No.11 incorrectly assumed that the horizontal section remains constant in size and form throughout the body

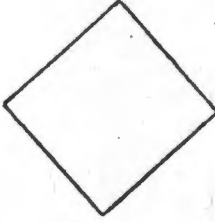

	NORTH-SOUTH VERTICAL SECTION	EAST-WEST VERTICAL SECTION	HORIZONTAL SECTION	ANSWER
3				

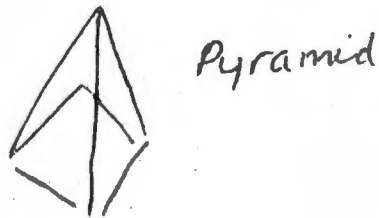

The synthesis of the sections of the tile baffled Students Nos.12, 13, 14 & 15. in 1980. When an explanation was offered after two minutes both had difficulty following until a polystyrene model was used.

Student No. 16 , with spatial MCQ drops of -36% and -17% relative to her non-spatial MCQ scores in April and June 1981, drew the following pyramid:-



Apparently she had difficulty mentally holding the "pointed" section in a horizontal position while manipulating the other two sections in her mind.

(iii) Cylinder

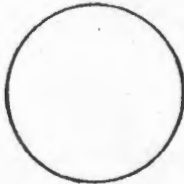
	NORTH-SOUTH VERTICAL SECTION	EAST-WEST VERTICAL SECTION	HORIZONTAL SECTION	ANSWER
4				

In 1980, No.12 took one minute to deduce the correct answer, but No.15 remained baffled yet again. He could not understand how a solid circular object could have straight lines in its sections. Not until the cylinder was held against the window and viewed from afar was the rectangular shape perceived and comprehended.

Student No. 20 (1980) confused the direction of cutting with the direction of viewing. If a cut were made frontally in the sagittal plane, for example, she did not realize that the eye then had to move horizontally through  $90^\circ$  to view the "inside contents" of the sectioned half-object from the side; or the half-object itself had to be rotated horizontally through  $90^\circ$  to be viewed frontally by the stationary eye.

Student No. 17 manifested the same problem as No.15 in 1980. When his fellow student, being tested at the same time, announced that he had drawn a cylinder, the discussion went as follows:-

Student No.17 (E): "No. It can't be. (Nervous laugh).  
Every section through a cylinder will be - will  
be - circular."

Interviewer (I): "Every section?"

(E): "No, not every section. But it wouldn't be a  
rectangle."

(I): "Let's look at a model of a cylinder."

(E): "I don't think a section that way - sagittal or  
coronal - would be rectangular."

(I): "Just hold it up to the light" (He does so with  
another nervous laugh.) Now what do you see  
there? (Long pause). Just hold it away from  
you. (Pause).

(E): "I see all the curves there." (Another  
nervous laugh.)

(I): "Ignore the curves. Now just make a section  
through here like this."

(E): "It makes a rectangle."

(I): "You see?"

(E): "Well, I wasn't sure." (Nervous laugh).

(I): "That's a hard one, isn't it?"



(E): "Yes." (Laughs nervously again).

In 1980 No. 21 contemplated the sections for several  
minutes before guessing a cylinder. Student No.22 took 30  
seconds this time, and was now using the test as learning.  
No.23 drew the correct shape, but  $90^\circ$  out of orientation:



*cylinder*

(iv) Horseshoe

	NORTH-SOUTH VERTICAL SECTION	EAST-WEST VERTICAL SECTION	HORIZONTAL SECTION	ANSWER
2				

Incomplete sketches for this were made by No.14 in 1980, and by five students in 1981:-

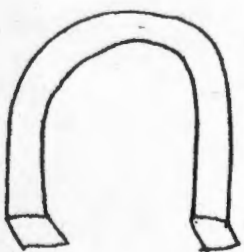

Student No. 14

HORSESHOE.



Student No. 28



Student No. 30

Solid semi  
circular object  
with a  
semi circular  
base -



Student No. 29



Student Nos. 10 and 31

Student No.4 also lacked drawing skill with reference to perspective:-

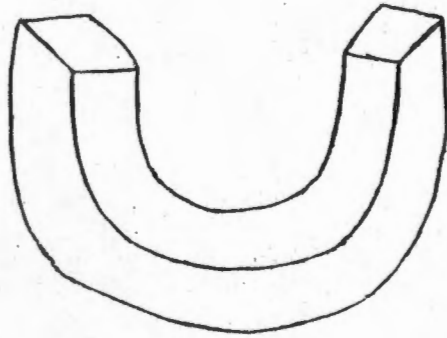

Student No. 32 grossly reduced the semi-circularity of the horseshoe:-







Student No. 33 :-



round hole thro  
middle of cylinder

(v) Punctured hemisphere

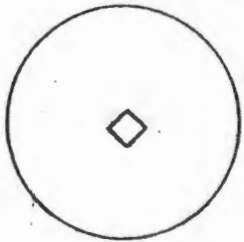
This item was used only intermittently with the 1980 students, depending on the time available.

	NORTH-SOUTH VERTICAL SECTION	EAST-WEST VERTICAL SECTION	HORIZONTAL SECTION	ANSWER
EXAMPLE				 <p data-bbox="1161 797 1406 958">A solid hemisphere with a square hole through its axis.</p>

The responses of students Nos.14 and 17 in 1980, reproduced below, are indicative of spatial visualization problems - involving lack of perspective in drawings and the unnecessary extension of lines when drawing three-dimensional objects on paper :-

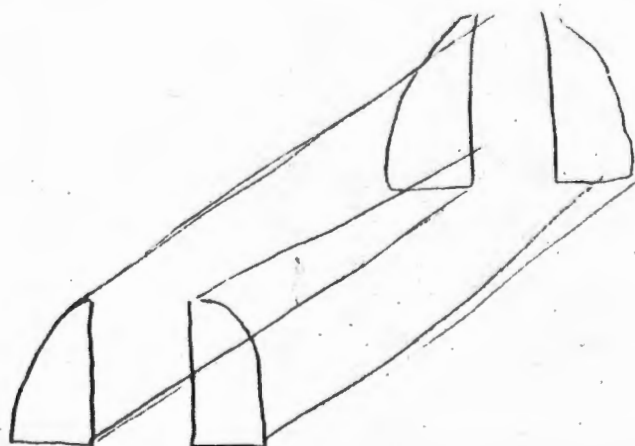
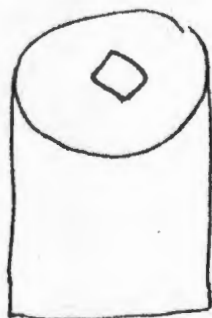

(b) CROSS-SECTIONAL DRAWING TEST(i) Semi-circular prism.

In 1980 the following glass model was shown to students who were required to sketch its appearance when viewed in the sagittal, coronal and horizontal planes:-

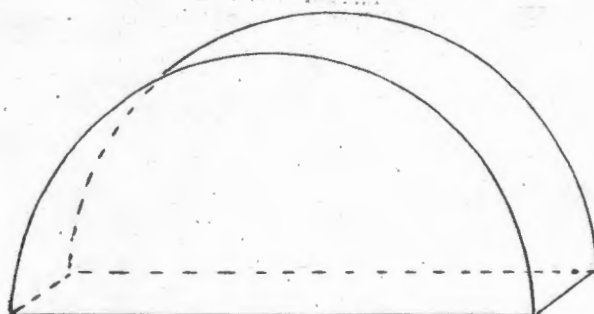

The horizontal section through the model of the prism on display caused the most difficulties. The drawings of the badly handicapped 1980 students

Nos. 3 and 35 are reproduced on the right. These two students were interviewed together. Since both of their sketches are incorrect, they were invited to look at each others' answers and to justify their drawings to each other without knowing the correct answer. Their thinking patterns are reproduced below:-

---

HORIZONTAL PLANE

---



---

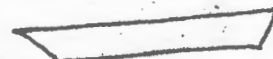

HORIZONTAL PLANE

---



- INTERVIEWER (I): "If we cut the prism horizontally through there, the figure seen will be - ?"
- Student No.35 (D): "Rectangle and rounded."  
 (I): "Look at each others' answers." (Laughter).  
 "You agree with each other in part. Who is right? Decide between you and tell me when you agree."  
 (D): "How did you get a straight line?"
- Student No. 3 (G): "Because it goes - I don't know." (Nervous laughter). "When you cut something it loses its circularity." (Pause). "Well, I'm thinking of those blocks that children play with, like, they've got a circle at the top, but the bottom is like a trapezium."  
 (I): "Convince each other that the edges are going to be either curved or straight."  
 (G): "Curved or straight?"  
 (D): "I'll go along with you - straight."  
 (G): "No, you mustn't." (Laughter).  
 (D): "Well, they have to be straight, but you are also wrong".  
 (G): "Yes, now I know." (She draws another diagram).  
 "Right angles."







Another student who experienced difficulty with the semi-circular prism in 1980 was No.1. His attempts at drawing the various sections are reproduced below:-







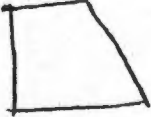

MODEL NO.	SAGITTAL PLANE	CORONAL PLANE	HORIZONTAL PLANE
1			

Clearly he did not appreciate that a sagittal section must be viewed along a normal to the plane of the cut; and his horizontal section is incorrectly orientated by  $90^\circ$ , and drawn without right angles.

In 1981 the following sketches were judged to be grossly distorted:

(1) North - South Vertical Section

SKETCH	STUDENT NO.
	11.
	37.
	38.
	32.
	39.
	40.
	41.

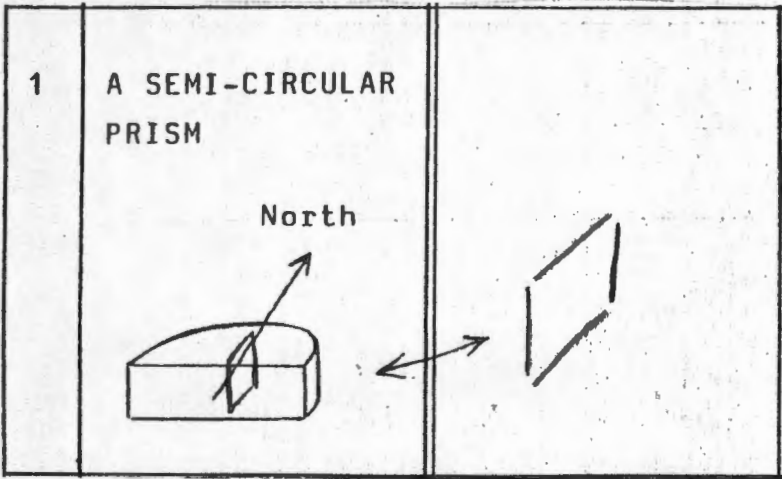

SKETCH	STUDENT NO.
	42.
	43.
	44.
 	31. 45.
 	46. 47.
	48.



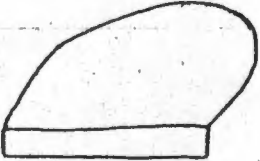

Student No. 49

(2) East - West Vertical Section

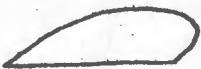

SKETCH	STUDENT NO.
	39  50  51
	52
	30.
	11.

SKETCH	STUDENT NO.
	53.
	48.
	10.
	56.

(3) Horizontal Section

SKETCH	STUDENT NO.
	55.
	56.

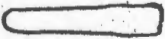
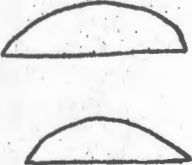
(3) Horizontal Section (contd.)

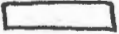
SKETCH	STUDENT NO.
	57.
	32.  29.
	30.
	58.
	59.

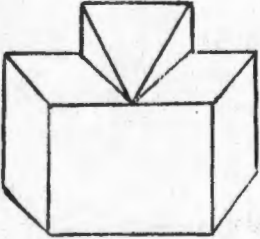
	OBJECT	NORTH-SOUTH VERTICAL SECTION	EAST-WEST VERTICAL SECTION	HORIZONTAL SECTION
3	<p data-bbox="212 376 312 409">North</p> 			

52 sketches indicating serious perceptual difficulties were recorded for the block combination. Since a given drawing error was made by upto half a dozen different students in many cases, the following page summarises the grossly defective sketches made by the students:-

(1) North - South Vertical Section

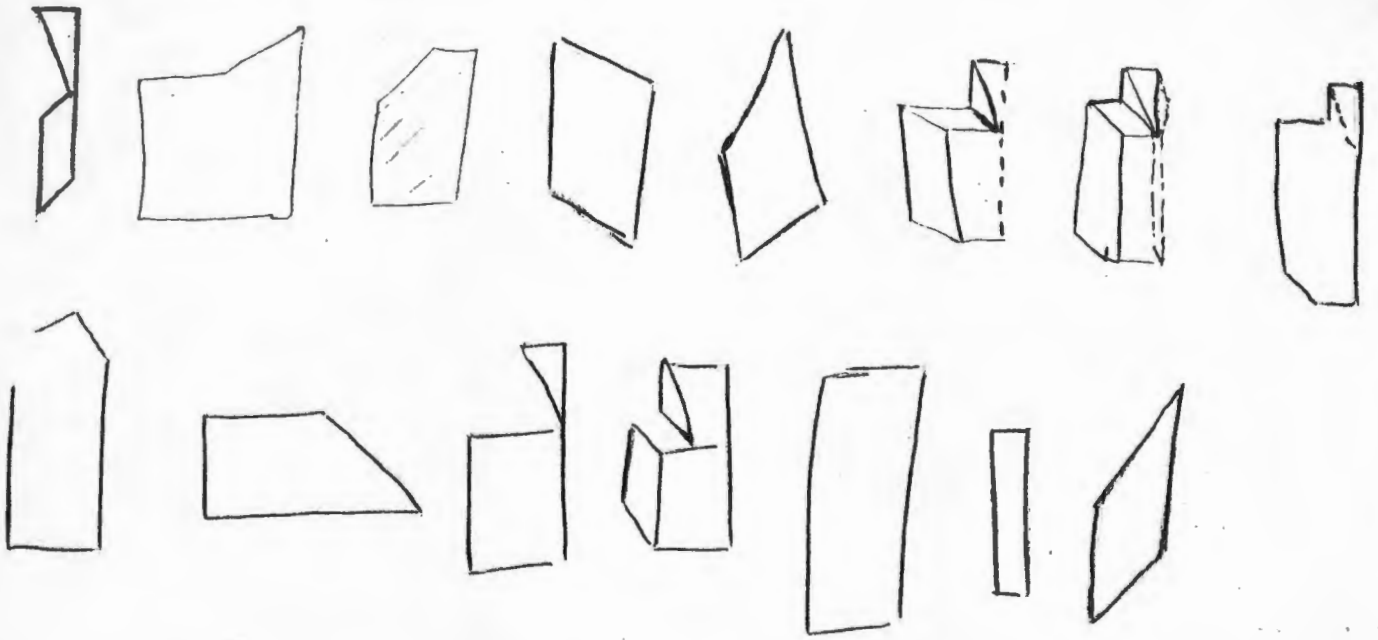

(2) East - West Vertical Section

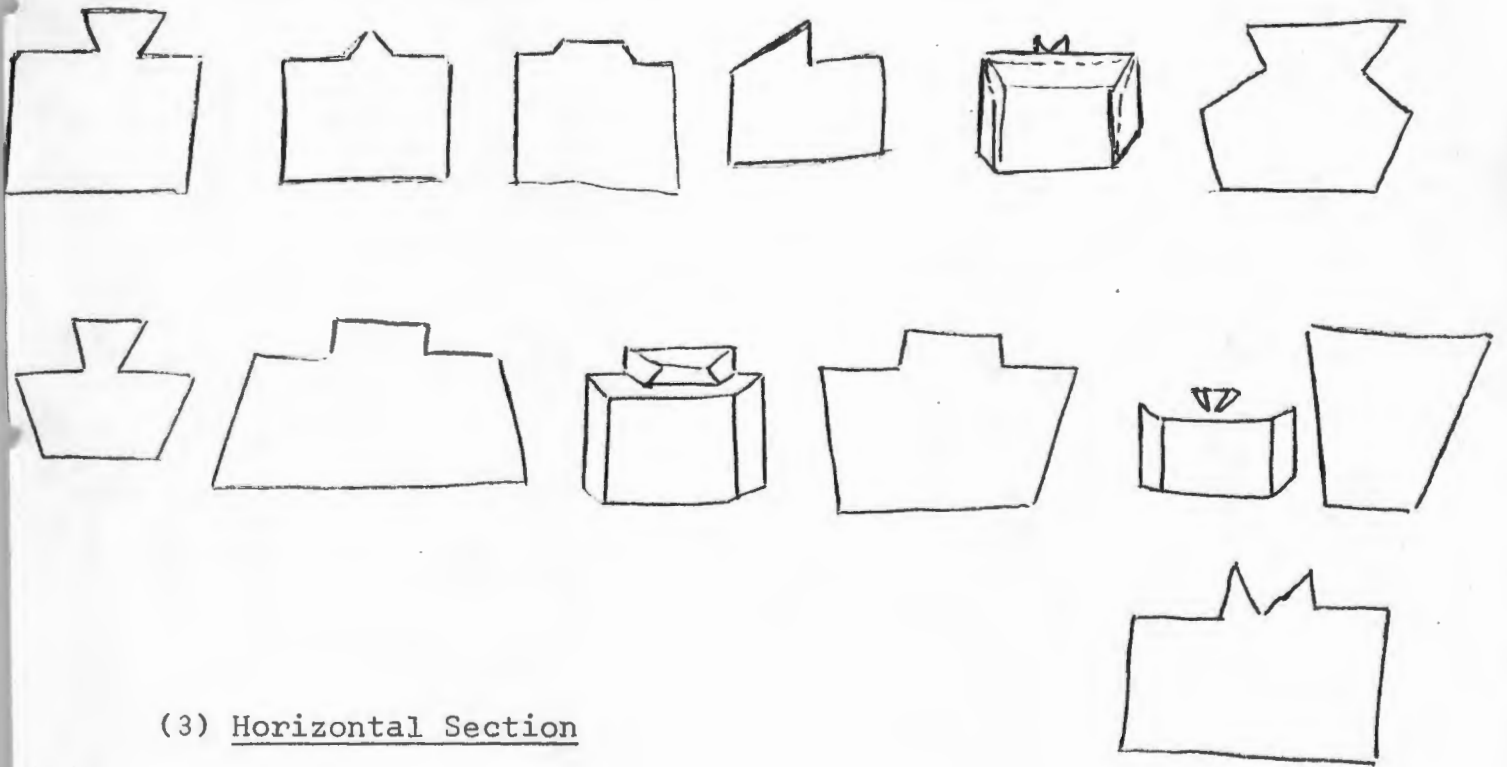

(3) Horizontal Section



MILD ERRORS IN SKETCHES MADE BY STUDENTS - BOTH SPATIALLY ABLE AND SPATIALLY HANDICAPPED (ONE PENALTY MARK WAS AWARDED FOR EACH ERROR).

(a) SPATIAL SYNTHESIS TEST

(i) Cone

47 students out of 154 incorrectly sketched an inverted cone in 1981 (31%) :

(ii) Horseshoe

23 students incorrectly sketched an elongated, rather than a semi-circular horseshoe in 1981 (15%) :

(iii) Tile

2 students drew the tile with the correct shape but the wrong orientation :



(iv) Cylinder

9 students correctly identified the object, but drew the cylinder considerably flattened (6%) :



(b) CROSS-SECTIONAL DRAWING TEST

(i) Semi-circular prism



(1) North-South Vertical Section (1981 students)

- a)  or  16 students made one of these errors (10%).
- b) 23 students sketched the North-South section as long as, or longer than, the East-West section (15%).
- c) 2 students drew the correct shapes, but in the wrong order.
- d)  4 students drew this shape.



(2) East-West Vertical Section (1981 students)

- a)  1 student.
- b)  1 student
- c)  4 students
- d) 2 students put the sections in the wrong order.





(3) Horizontal Section

- a)  2 students
- b)  1 student

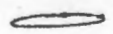

(ii) Kidney(1) North-South Section

- a)  4 students; b)  1 student.

(2) East-West Section

- a)  or  3 students
- b)  1 student
- c)  6 students

(3) Horizontal Section

- a)  1 student
- b)  1 student
- c) 2 students drew the sections in the wrong order.

(iii) Block(1) North-South Sectiona)  3 studentsb)  or  8 studentsc)  2 students(2) East-West Section

Nil

(3) Horizontal Sectiona)  2 students

b) 10 students drew the sections in the wrong order.

(iv) Eye(1) North-South Sectiona)  1 studentb)  16 students(2) East-West Section 4 students(3) Horizontal Sectiona)  11 studentsb)  3 studentsc)  2 studentsd)  1 studente)  1 student

f) 1 student drew the sections in the wrong order.

APPENDIX L

RELATIONSHIPS BETWEEN ANATOMICAL SPATIAL DEFICITS  
AND THE NUMBER OF ERRORS OR OMISSIONS IN  
STUDENTS' SKETCHES FOR POPULATION II

A PRACTICAL ANATOMICAL SPATIAL HANDICAP IS EVIDENT; FAILING PRACTICAL MARKS OCCUR FROM APRIL TO JUNE	AN MCQ ANATOMICAL SPATIAL HANDICAP EXISTS: DROPS OF 10% OR MORE RELATIVE TO THE MCQ NON-SPATIAL SCORES OCCUR	FAILURES IN PRACTICAL WORK ARE OVERCOME BY OCTOBER: THE PRACTICAL EXAMINATION IS NOW PASSED	FAILURES IN PRACTICAL WORK ARE OVERCOME BY NOVEMBER: THE PRACTICAL EXAMINATION IS PASSED	THE MCQ SPATIAL HANDICAP IS OVERCOME BY NOVEMBER: A DROP OF MORE THAN 4% RELATIVE TO NON-SPATIAL MCQ'S IS ACHIEVED	THE 1981 YEAR OF ANATOMY IS PASSED AS A WHOLE IN NOVEMBER	NUMBER OF STUDENTS IN THE GROUP	AVERAGE NUMBER OF DIFFERENT ERRORS OR OMISSIONS MADE IN THE STUDENTS' SKETCHES (MAX. 20)
YES	YES	NO	NO	NO	NO : FS or-FR	4	6,8
YES	YES	NO	NO	NO	YES	2	8,0
YES	YES	NO	-	NO	YES	4	5,0
YES	YES	NO	NO	YES	YES	1	6,0
YES	YES	YES	YES	NO	YES	7	5,9
YES	YES	-	YES	NO	YES	9	5,0
YES	YES	-	YES	YES	YES	8	5,4
YES	YES	YES	YES	YES	YES	7	5,3
YES	NO	NO	NO	-	YES	5	6,6
YES	NO	-	YES	-	YES	14	6,9
YES	NO	YES	YES	-	YES	9	6,2
NO	YES	-	-	NO	YES	27	3,3
NO	YES	-	-	YES	YES	7	2,0
NO	NO	-	-	-	YES	68	2,2
DATA UNUSABLE OR MISSING e.g. STUDENTS ABSENT, WITHDRAWN FROM THE COURSE, FAILING SO BADLY THAT THEIR MARKS CANNOT BE ANALYSED, ETC.							
						15	-

Sub-division of POPULATION II into 15 groups according to the severity and persistence of spatial handicaps in anatomy examinations throughout '98.

APPENDIX M

EXAMPLES OF STUDENTS' SPATIAL  
MISCONCEPTIONS IN ASTRONOMY

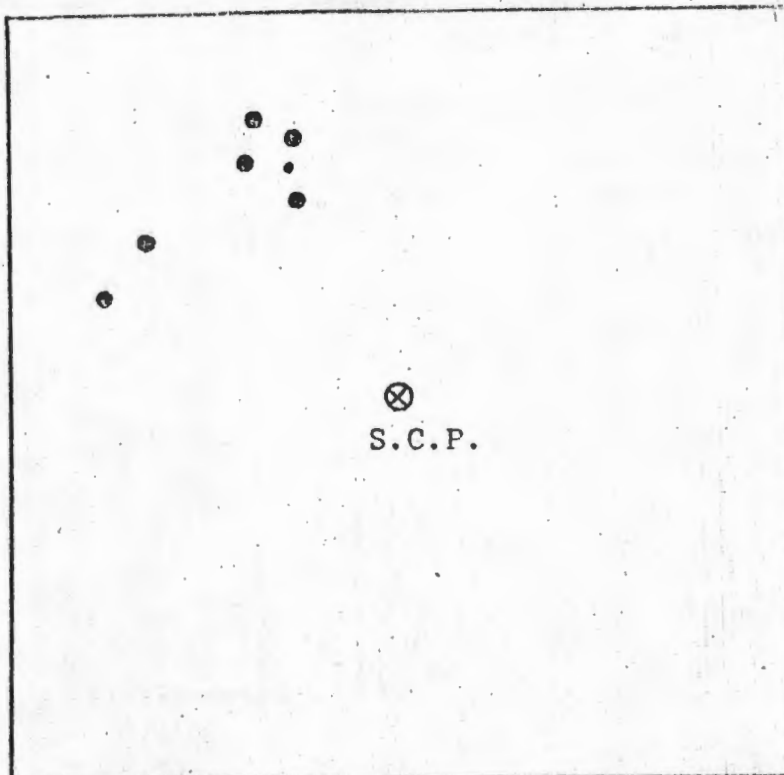
DIAGRAM A

The above DIAGRAM A depicts the position of the Pointers and the Southern Cross relative to the South Celestial Pole at 18h30 on July 30. Twelve hours later, at 06h30 on July 31, the position of the Pointers relative to the South Celestial Pole is depicted in DIAGRAM B. Draw in as accurately as possible on DIAGRAM B below, the new positions of the five main stars of the Southern Cross as they would appear at 06h30 on July 31.

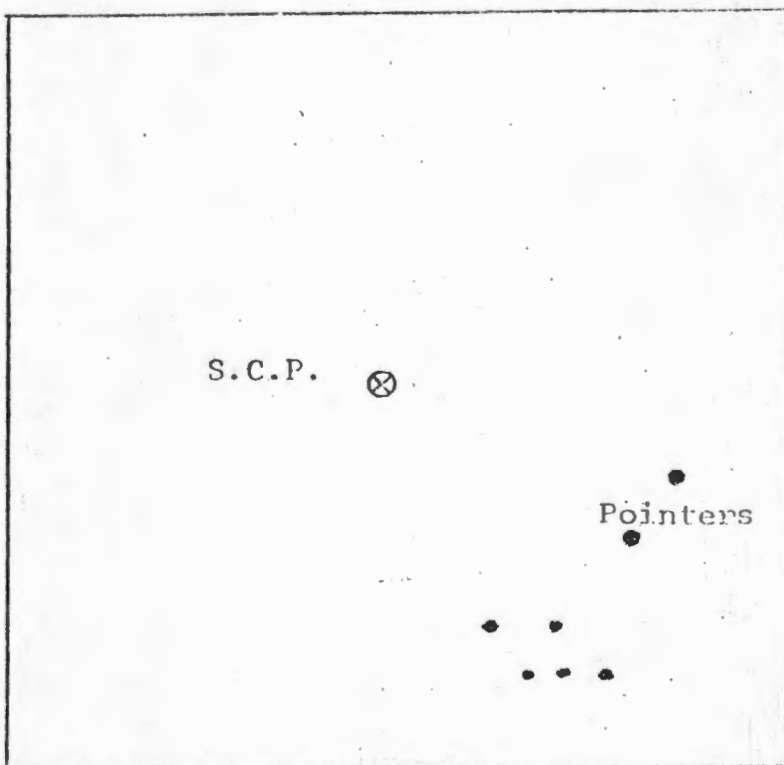
DIAGRAM B

Under what circumstances could a camera, photographing the surface of a planet, produce the following sequence of phases diminishing in size with time?

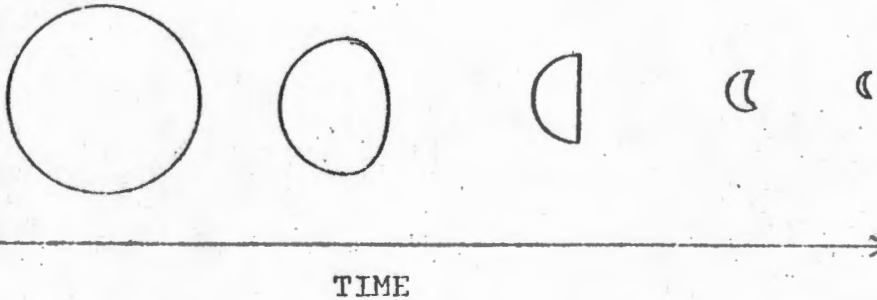

ANSWER: .. If... the... shutter... of... the... camera... ..  
 .. is... opened... for... only... short... periods... of...  
 time

(Be careful; the correct answer is unusual, and not immediately obvious at first glance).



(5)



If the Andromeda Nebula could be viewed side-on, its shape would appear somewhat like that depicted above. The little crosses around the core of the galaxy represent globular clusters.

Suppose that, instead, the frame of reference of the observer could be moved from above the page to the point P, looking at the plane of the Andromeda galaxy itself. What do you think the observer would see? Sketch the new appearance of the nebula in the space below, as the observer would see it from point P.

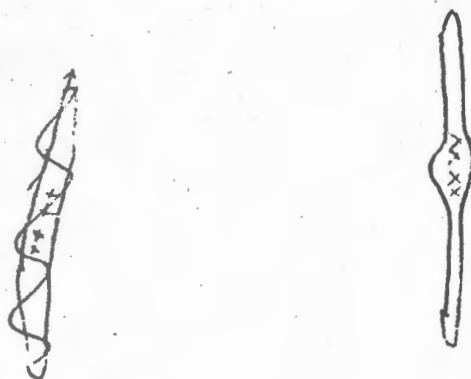

(5)

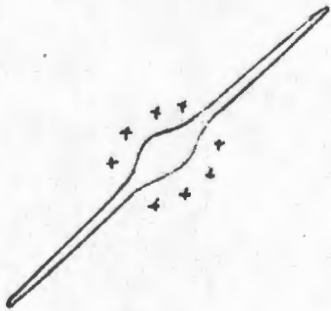

If the Andromeda Nebula could be viewed side-on, its shape would appear somewhat like that depicted above. The little crosses around the core of the galaxy represent globular clusters.

Suppose that, instead, the frame of reference of the observer could be moved from above the page to the point P, looking at the plane of the Andromeda galaxy itself. What do you think the observer would see? Sketch the new appearance of the nebula in the space below, as the observer would see it from point P.

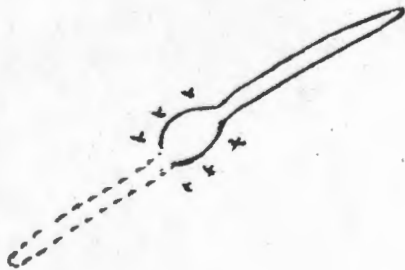

APPENDIX N

ERROR ANALYSIS OF THE  
FULL ASTRONOMICAL SPATIAL TEST

ERROR ANALYSIS OF ASTRONOMICAL SPATIAL TEST

Question	Percentage of Students Selecting Each Response (* indicates correct response)	Discrimination Index of each question : FAIR < 0,20 GOOD < 0,30 EXCELLENT < 0,40	Question Inversions Present?
(1)	(1) 19 (2) 0 *(3) 67 CORRECT (4) 7 (5) 7 (6) 0	0,50 Excellent	No
(2)	(1) 7 *(2) 74 CORRECT (3) 7 (4) 7 (5) 4	0,36 Good	No
(3)	(1) 15 (2) 15 *(3) 66 CORRECT (4) 4 (5) 0 (6) 0	0,35 Good	No
(4)	*(1) 82 CORRECT (2) 0 (3) 0 (4) 11 (5) 7	0,07 Poor	No
(5)	CORRECT : 46	0,21 Fair	No
(6)	CORRECT : 71	0,21 Fair	No

## Error Analysis of Astronomical Spatial Test - contd.

Question	Percentage of Students Selecting Each Response (* indicates correct response)	Discrimination Index of each question: FAIR < 0,20 GOOD < 0,30 EXCELLENT < 0,40	Question Inversions Present?
(7)	(1) 4 (2) 18 (3) 0 (4) 14 *(5) 39 } (6) 14 } 53 CORRECT	0,43 Excellent	No
(8)	CORRECT : 75	0,14 Poor	No
(9) (1)	CORRECT : 29 "SAME PLANE" : 32 "ABOVE THE PLANE" : 21 NO ATTEMPT : 18	0,14 Poor	Yes?
(9) (11)	CORRECT : 25 "CENTRE" : 32 "NEAR CENTRE" : 11 OTHER : 7 NO ATTEMPT : 21 "ON THE PERIPHERY" : 4	0,57 Excellent	No
(10)	CORRECT : 4 NO ATTEMPT : 36 OTHER : 60	0,07 Poor	No
(11) (1)	CORRECT : 46 NO ATTEMPT : 18	0,50 Excellent	No
(11) (2)	CORRECT : 71 NO ATTEMPT : 14	0,28 Fair	No

## Error Analysis of Astronomical Spatial Test, continued.

Question	Percentage of Students Selecting Each Response	Discrimination Index of each question :	Question Inversions Present?
	(* indicates correct response)	FAIR < 0,20	
		GOOD < 0,30	
		EXCELLENT < 0,40	
(12) (1)	Correct : 68	0,50 Excellent	No
(12) (11)	CORRECT : 68	0,50 Excellent	No
(13)	* (1) 43 CORRECT (2) 7 (3) 29 (4) 7 (5) 7 NO ATTEMPT : 7	0,14 Poor	No
(14)	(A) 14 (B) 0 * (C) 61 CORRECT (D) 4 (E) 14 (F) 4 NO ATTEMPT : 4	0,36 Good	No
(15)	(1) 0 (2) 7 * (3) 89 (4) 4 (5) 0	0,07 Poor	No
(16)	3 marks : 7 2 marks : 21 1 mark : 54 0 marks : 4 No attempt : 14	0,17 Poor	No
(17)	CORRECT : 50 NO ATTEMPT : 14	0,14 Poor	No

VOLUNTARY QUESTION	Number of students (out of 23 volunteers) selecting each response. (Correct response is circled)							
	A	B	C	D	E	F	G	N/A
18 (1)	1	1	4	2	5	⑥	0	4
18 (2)	1	8	1	0	1	0	⑩	2
18 (3)	3	⑪	2	0	0	2	3	2
18 (4)	⑪	2	2	0	0	1	3	4
18 (5)	1	0	⑭		6	1	0	1
18 (6)	0	0	2	11	⑤	0	0	5

For Question 18 taken as a whole, students failing the above test score an average of  $\frac{212}{6} = 37\%$ ,

whilst those passing the above test score an average of

$$\frac{311}{6} = 52\%$$

on question 18.