

# PRIMARY HEALTH CARE FACILITIES FOR STREET CHILDREN

A Study of the Street Children's Requirements  
in Designing Community Hospitals in Angola

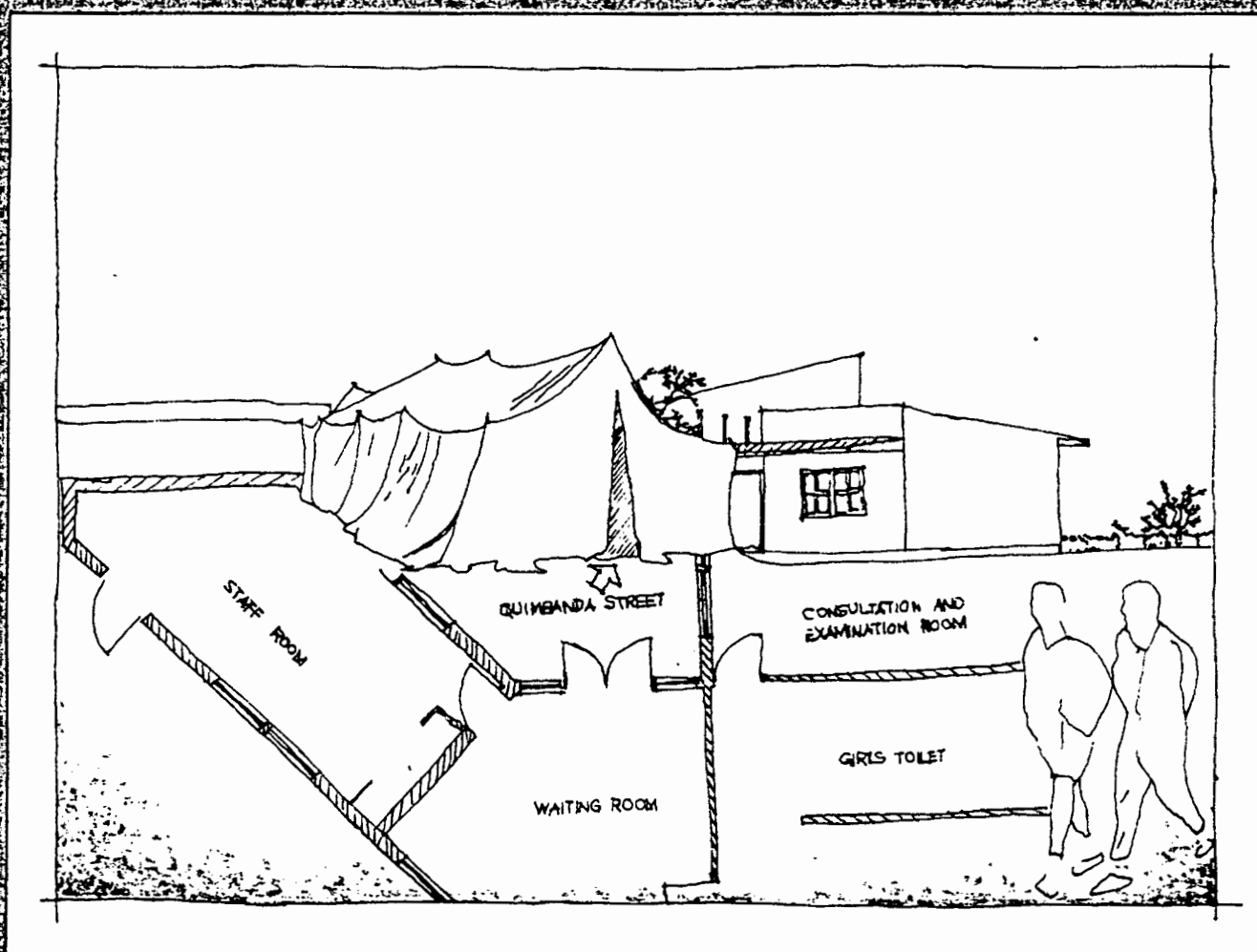

João Joaquim Gunza Cavota

The copyright of this thesis vests in the author. No quotation from it or information derived from it is to be published without full acknowledgement of the source. The thesis is to be used for private study or non-commercial research purposes only.

Published by the University of Cape Town (UCT) in terms of the non-exclusive license granted to UCT by the author.

# PRIMARY HEALTH CARE FACILITIES FOR STREET CHILDREN,

A Study of the Street Children's Requirements in Designing Community Hospitals in Angola

---

João Joaquim Gunza Cavota

A Dissertation Submitted to the Faculty of Fine Arts and Architecture of the University of Cape Town, Cape Town, for the degree of Master of Architecture

Cape Town, April 1997

The University of Cape Town has been given  
the right to reproduce this thesis in whole or  
in part. Copyright is held by the author.

## ABSTRACT

This dissertation studies the delivery of health care to street children. It investigates the existing street children's facilities and the health system in Angola in order to determine an appropriate type of health facilities for the special health needs of these children.

The study was based on a review of bibliographic material on street children and related subjects. The findings from this review were tested through a series of interviews with professionals working with street children in Angola and with street children randomly selected from shelters and on the streets in Luanda. The questionnaires were designed for evaluation of the street children's facilities, the health system and to determine street children's preferences and attitudes towards formal institutions in a context where the main cause of family disintegration was war.

The study concluded that street children's health needs in Angola would be better catered for through independent primary health centres provided with partial in-patient services (temporary sleeping and eating facilities for children under medical care). These centres would serve mainly children with no access to shelters and those living in shelters without health centres. The study formulates guidelines and presents a design example of the type of facility proposed.

## DECLARATION

I declare that this dissertation is my own, unaided work. It is being submitted for the degree of Master of Architecture in the University of Cape Town, Cape Town. It has not been submitted before for any degree or examination in any other University.

João Joaquim Gunza Cavota

Cape Town, March 24, 1997.

In memory of my beloved brother

André

Victim of the Angolan civil conflict

## ACKNOWLEDGEMENTS

I would like to acknowledge the guidance from my main supervisor Professor I.C. Prinsloo who supported me in this research since the preliminary studies stage; Ass. Prof. Derek Japha, my second supervisor and head of Masters Programme whose criticism and suggestions contributed positively to the final work.

My thanks to Ms O'Brei of Department of Social Work, Ms Scot of Department of Statistics, Keith Cattel of Department of Construction Economics and Management and Dr. Power of Department of Paediatrics at Red Cross Hospital for their help on aspects related to their specialities which this study dealt with.

I am deeply grateful to Nicola Keller who reviewed the style of this work. My special appreciation to Arlene Archer my English teacher and one of my best friends who taught me this language and who made my studies a pleasant experience.

I would also like to express my gratitude to the professionals working with street children who helped me in Cape Town and in Luanda, in particular Ms Coletta of Claremont Shelter, Dr. Manuela of the Angolan Institute of Children, and Dr. Casimira Bens of UNICEF office in Luanda, for their kindness in sharing their experiences with me; to Victor Leonel who helped me interviewing street children; and to all street children interviewed who responded openly to the questionnaires and who directed us to places where we could work safely.

Finally, I would like to thank the German Academic Exchange (DAAD) for their financial support; Otto Greger, Director of the Department of Architecture in Luanda, who played a key role for the award of this scholarship; and Ms Beata Kirch, Vice Consul of the German Consulate in Cape Town who has always responded promptly to all administrative matters related to the scholarship.

## LIST OF ACRONYMS

AIDS	- Acquired Immuno Deficiency Syndrome;
APV	- <i>Accao Pela Vida</i> (Action For Life): a Non-Governmental Organization in Luanda;
BIREMI	- A Brazilian medical database
FEBEM or FUNABEM	- <i>Fundação Nacional do Bem do Menor</i> (National Foundation for Child Welfare): A Brazilian state institutions network;
HIV	- Human Immuno-Deficiency Virus;
INAC	- <i>Instituto Nacional da Criança</i> (National Institute of Children - Angola);
INTERNET	- A worldwide computer network;
Kz	- Kwanzas: the Angolan currency;
MINARSE	- <i>Ministério da Reinserção Social</i> (Ministry of Social Reintegration): Angola;
NGO	- Non-Governmental Organization;
ONAM	- <i>Organização Nacional da Ajuda Multifacética</i> (National Organization for Outreach Help): a Non-Governmental Organization in Luanda;
UCT	- University of Cape Town;
UNICEF	- United Nations International Children's Emergency Fund;
WHO	- World Health Organization.

## TABLE OF CONTENTS

ABSTRACT .....	i
DECLARATION .....	ii
ACKNOWLEDGEMENTS .....	iv
LIST OF ACRONYMS .....	vi
LIST OF ILLUSTRATIONS .....	xii
INTRODUCTION .....	1
CHAPTER 2	
THE INTERNATIONAL PHENOMENON OF THE STREET CHILD .....	9
2.1 Introduction .....	9
2.2 History .....	10
2.3 Definition .....	10
2.4 Characteristics of the street children .....	11
2.5 Causes of the existence of the street children .....	12
2.6 Demography .....	13
2.7 Problems and health needs of street children .....	14
CHAPTER 3	
ANGOLA .....	16
3.1 General context .....	16
3.2 Climate .....	17
3.3 Economy .....	18

3.4	Population .....	19
3.5	Culture .....	20

## CHAPTER 4

### STREET CHILDREN IN ANGOLA .....

4.1	Statement of the problem .....	22
4.2	Field work .....	23
4.2.1	Method .....	24
4.2.2	Evaluation of the existing shelters .....	27
4.2.2.1	Number of shelters and period of their existence .....	27
4.2.2.2	Location .....	27
4.2.2.3	Programme and services provided .....	28
4.2.2.4	Type of construction .....	28
4.2.2.5	Capacity .....	28
4.2.2.6	Funding .....	29
4.2.2.7	Intake Criteria .....	30
4.2.2.8	Deficiencies .....	30
4.2.3	Mobile clinic .....	30
4.2.4	Communal kitchens .....	31
4.2.5	Opinion of the professionals working with street children .....	31
4.2.5.1	Shelters' principals .....	31
4.2.5.2	Government institutions .....	32
4.2.5.3	International Non-Governmental Organizations .....	32
4.2.5.4	Proposed improvement .....	33
4.2.6	Assessment of the actual health care delivery to street children .....	33
4.2.7	Suggested location of the street children's health centres .....	34
4.2.8	Results of interviews with street children .....	35
4.2.8.1	Sample .....	35

4.2.8.2	Age and sex .....	35
4.2.8.3	Origin .....	36
4.2.8.4	Schooling .....	37
4.2.8.5	Access to Health Care .....	37
4.2.8.6	Types of diseases, period of cure and place of convalescence ...	40
4.2.8.7	Attitude towards health facilities .....	42
4.2.8.8	Diet .....	43
4.2.8.9	Problems .....	43
4.2.8.10	Opinion on the creation of a health care centre exclusively for street children .....	43
4.2.8.11	Proposed location .....	44
4.2.9	Summary of the health care problem relating to street children in Angola ..	44

## CHAPTER 5

	HEALTH FACILITIES .....	46
5.1	Street children's problems in regard to facilities .....	46
5.2	Definition of the type of health facilities required .....	48
5.2.1	General considerations .....	48
5.2.2	Functions .....	50
5.2.3	Climate considerations .....	50
5.3	Primary health care facilities for street children .....	52
5.3.1	Objectives .....	52
5.3.2	Criteria for location of health centres for street children .....	53
5.3.3	The user group and their requirements .....	55
5.3.4	Size and number of units required .....	57
5.4	The prototypical building .....	64
5.4.1	Design brief .....	64
5.4.2	Schedule of accommodation .....	66
5.4.2.1	Description of activities and rooms .....	66

	5.4.2.1.1	Reception .....	66
	5.4.2.1.2	Waiting area .....	70
	5.4.2.1.3	Consultation, examination and treatment rooms ..	72
	5.4.2.1.4	Sleeping area .....	74
	5.4.2.1.5	Staff room .....	77
	5.4.2.1.6	Kitchen .....	78
	5.4.2.1.7	Laundry .....	80
	5.4.2.1.8	Store .....	80
5.4.3	Construction materials .....		83
5.4.4	Services .....		85
	5.4.4.1	Water supply .....	85
	5.4.4.2	Electricity .....	87
	5.4.4.3	Sewage .....	87
	5.4.4.4	Ventilation system .....	88
5.5	Project implementation .....		88
	5.5.1	Budgets .....	89
	5.5.2	Cost control assessment .....	90
5.6	Case study .....		93
	5.6.1	Location .....	93
	5.6.2	Design concepts .....	95
	5.6.3	Technical specifications .....	97
	5.6.3.1	Structure .....	97
	5.6.3.2	Walls .....	97
	5.6.3.3	Roofs .....	97
	5.6.3.4	Openings .....	99
	5.6.3.5	Technical installations .....	99

## CHAPTER 6

CONCLUSIONS .....	100
-------------------	-----

APPENDIX A

DETAILS OF THE CASE STUDY DESIGN ..... 105

APPENDIX B

PHOTOGRAPHS OF STREET CHILDREN AND SHELTERS IN LUANDA ..... 109

APPENDIX C

QUESTIONNAIRE FORMS ..... 114

REFERENCES ..... 122

SELECTED BIBLIOGRAPHY ..... 125

## LIST OF ILLUSTRATIONS

1.	Table of proportions of street children in Luanda according to their origins .....	36
2.	Table of street children's visits to health facilities in Luanda .....	38
3.	Table of frequency of sickness of street children in Luanda .....	39
4.	Table of health facilities used by street children in Luanda .....	39
5.	Graph showing the most frequent diseases reported by the street children in Luanda .....	40
6.	Table of correlation between type of diseases and sleeping place during convalescence period .....	42
7.	Table of preferences per type of health facility among street children in Luanda .....	43
8.	Solar Diagram showing advised building orientation in Luanda .....	51
9.	Table of planing units of a health centre for street children, their areas and occupancy .....	63
10.	Relationship matrix .....	64
11.	Flow chart .....	65
12.	Prototypical reception .....	69
13.	Prototypical waiting room .....	71
14.	Prototypical consultation, examination and treatment room .....	73
15.	Prototypical sleeping room .....	76
18.	Prototypical staff room .....	77
16.	Prototypical kitchen and laundry .....	79
19.	Prototypical store room/pharmacy .....	81
17:	Prototypical bath and toilets .....	82
21.	Case study: site plan .....	94
23.	Case study: floor plan .....	96
24.	Case study: cross section and elevations .....	98

## INTRODUCTION

This research was undertaken with the objective of studying the provision of primary health care facilities with a special emphasis on the needs of street children in Luanda in Angola.

The health care delivery process has generated some debate within the medical profession as to what type of facilities are the most appropriate for street children, and there is no consensus or single obvious solution. The basic question is whether stand-alone health care facilities for street children are viable, or whether these facilities will work only if they are attached to other facilities which street children will use, such as shelters.

Some of the major issues in this debate relate to institutional character and the responses of street children to it. Street children are widely held to ignore formal institutions for psychological reasons, and because they fear to be involved with official authorities (Scheper-Hughes 1994; Cockburn 1991 et al.). For this reason, many researchers (Ross 1991 et al.), including some South African doctors specialising in health care for children consulted prior to the beginning of this study, considered shelters with attached medical facilities to be the best option, because these facilities have shown to be effective in situations where street children are suspicious of other institutions. On the other hand, many books and articles discussing health care problems faced by street children have considered typical existing health facilities to be inadequate. Examples of the inadequacy of these facilities in assisting street children are the findings from studies entitled "Health Status of Street Children in Cape Town" by Gebers (1990), "Health and Health Needs of Homeless and Runaway Youth" by Farrow (1992) and "The Neglected Health Care Needs of Street Youth" by Sherman (1992). These studies investigate the extent of the health problems of street children and they make an appeal for urgent restructuring of health systems in order to provide proper health care to these children. The importance of shelters as facilities for street children is not denied in this study, nor are the conclusions reached by previous studies in this field regarding the special psychological characteristics of the street children.

Street children are a particularly pressing problem in Angola. They are one of the negative effects of war

which the country has experienced for a long period of time. Children separated from their families left their homes seeking safer places, and then found themselves living in the street life. What these children need above all are shelters and food in order to survive, and for this reason most of the funds and initiatives dealing with street children in Angola have been directed to the provision of shelters and food. Some of these shelters are provided with basic health care facilities, but for the most part street children are forced to seek their health care in an already overburdened public health care system that has erected various obstacles to their obtaining reasonable access to health services.

Good health is the primary condition for every human being that must be ensured for one's success in life. When someone plans his or her future the execution and success of such projects depends mostly on the health status of that person at a specific time. Health care is particularly important to street children. It is necessary to take into account that life in the street exposes them to many sources of health hazards, for example, poor diet, inappropriate sleeping arrangements, scavenging, and also their vulnerability to many kinds of injuries due to their being knocked down by cars or assault (by older street children's gangs or other members of society or even the police). There are also problems arising from the abuse of solvents and drugs and from sexual abuse, which spreads sexually transmitted diseases among the street children.

When these health problems occur, street children in Angola face two problems when it comes to accessing health care. The first is that facilities to cope with their special needs are not available. The second is that they must seek health care within a system that performs poorly in general terms. Most underdeveloped countries have had many difficulties in providing health care to their inhabitants, and these general difficulties have created problems for street children seeking access to health care. In Angola, and especially in Luanda, the problem with public health care provision is reflected in a poorly developed health care structure. There are three levels in the Angolan health care system hierarchy:

- Level one, constituted by the regional and provincial general hospitals and some specialized hospitals, such as maternity and hospitals for infectious diseases.

- Level two, constituted by general and specialized clinics.
- Level three, constituted by primary health centres.

There are only three hospitals at the provincial level to deal with many people, and these hospitals are supported by a few level-two clinics and primary health centres. Many people with health problems that could be treated in small health centres have therefore been forced to go to the provincial hospitals. This problem was aggravated by the poor services given at the existing community health centres, and by the undefined boundaries of tasks between the different levels. The World Health Organization and UNICEF give special attention to the care of children and their mothers. They are the most vulnerable groups, especially in developing countries, and here priority is given to primary health care (Power 1994). These are the groups particularly affected by problems in the public health care system in Angola, which cannot deliver effective levels of primary health care.

Even if the Angolan public health care hierarchy was fully functional, however, it might also be insufficient to deal with the special health care problems of street children. Street children are prone to the same diseases as any other children, but it is more complicated to treat them. Even if they are given medicines, it does not help if after treatment they must face the harshness of nights in the open air. They need an appropriate place to stay, at least during the period of medical care. However, in-patient services are provided only in the second and higher level hospitals. This means that street children can be prevented from returning to the streets only if they make use of the facilities of hospitals of second and higher levels. Admissions to these type of hospitals in Luanda were conditioned by referrals from trusted entities and children were required to be accompanied by adults. This obstacle could be avoided by suggesting to authorities not to apply these rules to street children. This is unlikely to happen due to the overcrowding which provincial hospitals are confronted with. Many of the diseases from which street children suffer do not require hospitalisation in the case of patients with access to housing. Hospitalisation is required only because they have nowhere else to go, and street children therefore would take up valuable space in these facilities for this reason alone, i.e. medical conditions which could be dealt with further down the

health care hierarchy must be referred to hospitals to ensure recovery.

This research was, therefore, prompted by two main considerations that makes plausible the hypothesis that specialised health facilities for street children may be the best option in Angola. First, authorities have distinguished between street children in contexts where poverty or other similar social problems are the primary cause of family breakdown, and contexts where war or civil strife is the primary cause. Angola is in the latter category, and it is not clear whether street children there would necessarily react to institutional facilities in the same way as street children in different contexts, where they are on the streets for reasons such as the breakdown of families. Second, there are not enough shelters to get all street children off the streets in Angola, and it is unlikely that funding for sufficient shelters will become available in the short or medium term, therefore many street children's' health care needs are not catered for except by a patently malfunctioning public health care system.

The study addresses the following questions:

1. In what ways have existing primary health care facilities failed in providing for the health care needs of street children?

This question is discussed in Chapter Two, Chapter Three and in the first section of Chapter Five. Chapter Two is a review of the street child phenomenon around the world, in order to establish trends of primary health care delivery to street children. This chapter deals with findings from the review of international literature. Chapter Three stresses the economic, social, cultural and geographical aspects of Angola, which constitute the background of the street children in this country. The section discussing street children's problems in regard to facilities (in Chapter Five) concludes the discussion of this question.

2. Are street children in Angola likely to use specialised primary health care facilities?

The answer to this question is found in Chapter Four. This chapter presents the result of the field work conducted in Angola and it discusses the implications of the outcome to the health care delivery to street children there. The questions this study aimed to answer required an in-depth study of special aspects in countries where the main cause of street children were war or civil strife. The conclusions about the special psychological characteristics of street children were mostly based on studies conducted in developed countries, or in developing countries which were not at war. It was therefore necessary to study attitudes of street children with different background than the background of those children which other studies were focused on. Angola was chosen as the venue for the field work, since this is a typical country where the effects of war are still visible.

3. Are primary health care facilities catering just for street children possible in the economic and medical context of Angola?

This question has two components which are addressed. The first component is the economic aspect of Angola which is introduced briefly in the background section, in Chapter Three, and it is enhanced in the cost control assessment section in Chapter Five. The first section gives an overview of the economic situation of the country at the time of this study and in the past, and the second section analyses its implications to the provision of health care facilities for street children.

The second component is the medical aspect, which is dealt with in Chapter Four based on the result of interviews with doctors and street children in Angola.

Chapter Five is a discussion of the issues raised in the preceding introductory chapters. This discussion is complemented with guidelines for designing facilities of the type found to be the most suitable for the delivery of health care to street children in Angola, and a design example of such facility.

Chapter Five gives answers to the following questions:

4. What features should distinguish health facilities for street children from ordinary primary health care facilities?
5. How should these facilities be integrated into the Angolan health care system and how should they relate to other institutions offering services to street children?
6. How could primary health care facilities catering for a broader range of users be adapted to cater better for the special needs of street children?
7. How should guidelines be written to communicate the core requirements of facilities for street children?

These questions required research on the following core issues:

- Economic, social and medical constraints; to determine whether specialised facilities for street children were feasible and possible;
- Architectural innovations (as opposed to administrative or social); to determine the extent to which such innovations could assist in better catering for the medical needs of street children.

In addition to these core issues, the following background issues were also investigated:

- The existing health-care hierarchy; this was necessary to illustrate the shortage and/or inadequacy of the small health centres in general, and how they dealt with the street children in particular;

- The medical problems of the street children; to show in what ways they were badly catered for.

To address these issues and questions the study required the following:

- Library research to establish whether there were precedents elsewhere for clinics or other health facilities dealing especially with street children;
- Discussion with primary health care professionals about the problems with actual approaches in providing primary health care facilities in Angola;
- Structured interviews with a statistically valid sample of street children in Luanda to identify their attitudes to health care facilities. For the interviews, the questionnaire forms were drawn up in Portuguese. These forms were completed during the interviews. Some observations and important opinions that did not fit into the form were recorded on tape or written on a separate sheet of paper and attached to the form for later processing;
- Structured interviews with health care professionals, shelters' principals, representatives of Non-Governmental Organizations and representatives of Governmental institutions about the special needs of these children;
- Studies of existing shelters and community health care centres to identify deficiencies. This was done by fieldwork in Luanda. Photographs of important aspect of buildings were taken;
- Identification of the economic and medical constraints on the provision of specialised facilities;
- Analysis of data to establish what architectural approach best suited to providing the type of facility needed, leading to the development of guidelines for these facilities;

- Studies of the form of architectural guidelines for public facilities;
- Studies of prototypical project units of the type of facility needed;
- Execution of a design to test the guidelines.

This required as primary material results of interviews and observations in the field. The secondary materials were books, journals, and reports dealing with the health care needs of street children.

The principal objective of this research was therefore to study health facilities for street children from an architectural point of view, focusing on space planning, functionality and appropriate character, and taking into consideration economical and social constraints; to investigate the viability of stand alone health care facilities for street children in Luanda.

## CHAPTER 2

### THE INTERNATIONAL PHENOMENON OF THE STREET CHILD

#### 2.1 Introduction

Homelessness is a phenomenon associated with chronic poverty. This phenomenon is observed both in rich and poor countries. The imbalance of distribution of wealth, wars and other natural catastrophes leave many families with no resources which enable them access to proper housing and services. Many of these families have the streets as a resort for their livelihood and shelter.

Street children and street youth are homeless young people and they are the result of family disintegration which is, in its turn, a result of poverty in some countries, and war in others. The reason for family breakdown in countries at war can also be poverty, since the war breaks the economic system and settlements of a country leaving people poor and homeless.

There has been discussion whether or not it is possible to bring about the extinction of the street child phenomenon. The extinction of this phenomenon is possible if all factors that cause the existence of street children are eliminated. Many researchers have concluded that the key for preventing children from becoming street children is family support, and to minimise the problems faced by poor families.

Poverty in developing countries can not be eliminated in a short period of time. Even in rich countries there are many families living at the same level of poverty as poor families in developing countries. Given the fact that the street child phenomenon is a contemporary dilemma of all countries, and the numbers are constantly increasing, facilities for them should not be restricted to certain groups. They should be accessible to all street children, they should be available whenever they are needed and there should be facilities for interventions in all sectors. These facilities should be flexible for later conversion in the case

of the extinction of the phenomenon. Although the extinction of street children in a country is a very remote possibility, it is possible that demands could decrease and no longer justify the provision of such facilities. At the same time efforts should be made to finding solutions for reintegration of street children into their communities and measures should be taken for prevention of family disintegration in order to reduce the number of street children or keep all street children off the streets.

## 2.2 History

The phenomenon of street children has been observed for many years. Abandoned children existed in many ancient societies. It is only the nature of the concept which has been changing with time. In the Roman Era, unwanted children were sold as slaves; in the Middle Ages, there were many children surviving in rural areas on their own, because they had lost their parents in war; and during the industrial revolution in London, an estimated thirty thousand children were living on the streets (Peacock 1994).<sup>1</sup>

However, the phenomenon has become a matter of social concern only recently (Cockburn 1988; Keen 1990 et al.). Since the early 1980's there has been an increasing world wide effort monitored by UNICEF in order to minimise the problems faced by these children as a short term objective, and to determine solutions for preventing children from leaving their homes, as a long term objective.

## 2.3 Definition

The following definition of street children given by UNICEF (Inter-NGO 1983) is adopted for the purpose of this study.

---

1

*There is very little publication on the history of street children. Most discussions on this issue refer to one book, by Peacock (1994).*

*A street child is any boy or girl who has not reached adulthood for whom the street (in the widest sense of the word, including any unoccupied dwellings, waste lands, etc.) has become his or her habitual abode and/or sources of livelihood and who is inadequately protected, supervised or directed by a responsible adult.*

The street children are classified in two categories according to their relationship to the streets: children "on" the streets and children "of" the streets. Children "on" the streets are children working on the streets who return home at night. Children "of" the streets are those children who live on the streets. The field work in Angola was targeted mainly to the children "of" the streets. Even though children "on" the streets face the same health risks as the children "of" the streets, they usually have some support from their families. Therefore if children in this category had health problems their relatives would help them in finding sleeping arrangements.

Excluding stereotypes associated with street children, many studies use other terminologies such as "homeless children", "runaway children", "street youth", "homeless youth", etc. The reason for diversity of designations given to street children is the ambiguity of the concept of childhood. The age or stage in the life of a person where childhood stops and where adulthood starts is not clearly defined (Burman 1988). The age of transition is usually determined by law and it changes significantly from one law to another. Therefore, there is not a specific range of age for street children and another one for street youth. In this study both groups are considered as a whole.

#### **2.4 Characteristics of the street children**

Street children in various cities share some common characteristics, although they have to adapt themselves to the specific conditions of the city they live in. The common characteristics related to their health problems are:

- Suspicion - street children are held to be very suspicious of adults. Most of them have experienced many social atrocities ranging from physical harassment to sexual abuse. These constitute the main reasons why street children consider that adults have abandoned them and it makes these children distrust formal institutions and reluctant to disclose true stories (Cockburn 1991 et al.).
- Low self esteem - the majority of the street children believe that they do not have any future and that they have no ability to perform a valuable activity in society.
- High risk behaviour - many studies on street children (Howard, 1993 et al.) have found that many of them were mentally disturbed, and that they were highly suicidal. Abuse of drugs and solvents is another factor contributing to their psychological disturbances.

Street children are of both sexes and they are usually found in the city centres, commercial areas and tourist areas. The activities of street children include carrying bags, car washing, selling goods, car parking, petty theft, prostitution, etc.

## **2.5 Causes of the existence of the street children**

The existence of street children is attributed to many causes. The most common reasons given in many studies on street children are:

- Poverty
- Unemployment
- Overcrowding
- Family upheaval
- Parental rejection

- Alcohol abuse among parents
- School failure
- Hope for freedom on the streets.

Another reason that is held to cause home withdrawal for many adolescents is sexual orientation. Kruks (1991), found 68 street youth that identified themselves as homosexuals in a study of 620 street youth receiving medical care at a children's hospital in Los Angeles. Of these, 80 per cent are homosexual street youths and they stated that their sexual orientation was the primary cause of their being on the streets. They were forced to leave home because of negative preconceptions among parents and society in general associated with homosexuality.

It is also important to consider that the number of street children tend to increase during periods of instability or periods of considerable social change (Peacock 1994).

## **2.6 Demography**

The exact number of street children in each country is difficult to determine. The statistics available are based on "guess-estimates"(Gebers 1990). There is an estimated number of 30 million street children around the world, according to UNICEF. Of this number about 75 per cent are children "on" the streets and they are mostly boys. Street girls constitute approximately one third of the total. The largest number of street children is said to be found in Brazil which has between 7 to 8 million children living "on" the streets (Rosa 1992).

## 2.7 Problems and health needs of street children

*"Life without shelter corrodes physical well-being in 1000 different ways, most of them too obvious to belabour here. Much that ails children requires little than a day or two at home in bed - but what if you have neither home nor bed? Nothing is quite so therapeutic to the ailing child as the tender, loving care of a parent. But homelessness is a means of existence in which tenderness, love and care are often in short supply."* (Wright 1993a)

Street children are exposed to many health hazards. They face problems resulting from poor diet, inappropriate sleeping arrangements, being knocked down by cars, and assaulted by older street children's gangs and by other members of the society. The diet of street children is generally poor, and scavenging is a regular practice for many street children as a means of obtaining food. They sleep under bridges, in bushes, abandoned cars, at doorways of buildings, and so on (Gebbers 1990; Wright 1993b et al.). Other health problems arise from substance abuse, sexual abuse and suicidal behaviour.

Many studies on the health of street children have found the health status of these children to be poor. They were found to be underdeveloped physically in relation to their ages. Comparisons between sheltered homeless children and housed poor children concluded that homeless children had poorer health status than housed ones. These children were more likely to have anaemia, measles and less immunization than their counterparts (Parker 1991 et al.). Gebbers (1990), found 59.7 per cent in a sample of 159 street children in Cape Town that had never visited a health facility since they had been living on the streets. Wright (1993b), found 51 per cent in a sample of about 1016 street children that had not been seen by a physician or other health professionals for more than one year when he analyzed data of street children seen at the "Proyecto Alternativos" in Tegucigalpa (Honduras) between the age of 1 to 22. In the same study 5 per cent had never been seen by a physician before the programme started.

## CHAPTER 3

### ANGOLA

#### 3.1 General context

Angola is an African country situated on the South West coast of Africa. The country lies between the 4'22" and 18'03" latitudes South, and 24'05" and 11'41" Longitudes East of Greenwich. The country shares borders with the Republic of Congo in the North; with the Republic of Zaïre in the North and North-East; with Zambia in the East; and with Namibia in the South. The Western border is the Atlantic coastal line. The total area of Angola is of 1 246 700 square kilometres divided into 18 provinces, with Luanda the capital.

Angola is a country with a very long history of war. The country has experienced war since independence in 1975, as an extension of the guerrilla warfare against the Portuguese colonialists. The most devastating period of war started in the early 1980's, affecting especially the South and the South-East of the country. Since then people have been living under a destabilized economy: roads have been blocked; and bridges and railways have been destroyed. Some attempts were made to restore the functionality of the main roads, but restored road systems did not last long before being destroyed again. This situation has made the transportation of goods and communication by land non-viable.

Disorganization is present in the country in all sectors. There are high levels of corruption, a high rate of inflation, high costs of living, and widespread hunger and poor standards of health care. In the field of architecture and construction there has been a complete absence of housing policies and public services development programmes, and very little actual provision of building and services has taken place. So, as an alternative, people built informal settlements surrounding the urban areas, the

"*Musseques*" as they are called in Angola, which literally means '*The unpaved suburbs*'.

During the most intensive period of conflict, the places of relative safety were the cities, in particular those on the coast. Luanda, as the capital of the country, was the safest place. In addition to this, the country has been living on imported goods, the primary places of delivery for these goods have been the "*4 de Fevereiro*" airport and "*Porto de Luanda*" harbour. Only an insignificant amount of goods could arrive at other provinces. Some of these goods were lost in struggles during transportation, and more were stolen from the stores while waiting for transportation. Therefore people sought Luanda not only for safety, but also as a way to be closer to the source of the basic products.

### 3.2 Climate

The climate of Angola is tropical hot humid, and it is traditional sub-Equatorial climate in the North of Cabinda province. Its climate alternates a dry and cold season with a rainy and hot one. However, the climate varies significantly throughout the country influenced by the following factors:

- Difference of latitude - from the North region to the South region of the country;
- Difference of altitude - from the coastal region to the high plateau in the central region and;
- The cold Benguela Current.

These three factors make temperatures decrease from North to South, and from the coast to the interior regions. Hence four zones are distinguished:

- A hot zone with heavy rainfalls in the Cabinda province;
- A humid zone with moderate temperatures in the high plateau in the central region;
- A dry zone with moderate temperatures in the coastal zone from Luanda to Namibe and;
- An arid zone with high temperatures in the desert of Namibe.

### 3.3 Economy

The general context of Angola was highly marked by the effects of the war and by the inappropriate administration of natural resources. Before independence, 85 per cent of the population (the rural population) grew their own food. Angola exported oil, diamonds, iron ore, coffee, sisal, cotton, bananas and sugar (Bhagavan 1986).

The state of economy inherited after independence was poor. When the colonialists realized that the independence of the country was evident, they started leaving the country taking with them skilled labour and machinery. They destroyed some of the infrastructure they could not take with them (Bhagavan 1986). This state of economy required extensive reforms and reconstruction, but instead, the country emerged into a new era of civil conflicts which destroyed the remaining infrastructure and human resources left.

The main sources of income during this period were the oil industry and diamonds. However, the income from these resources were mostly spent on defence. There were no investments in the development of the industrial sector; agriculture has been made impractical through lack of resources. The country relied on imported goods and on international aid.

Inflation had reached high rates, accompanied by weakening of the currency in relation to the US Dollar (1\$ = Kz78 000 in April 1996). The high level of corruption was another factor which contributed to the economical instability in Angola. As a result of these factors associated with low salaries, most people had low purchase capacity, which forced many people (including children) to sell at informal markets or even on the streets as an alternative source of income.

Since the problem of street children has become aggravated, international relief agencies have extended their funding programme range. Initially representatives of these agencies were only involved

in rescuing people (especially women and children) from the most affected areas to safer places, and providing them with basic products and health care. Their activities were afterwards extended which then included helping local NGO's in funding projects destined to street children. It was therefore, the responsibility of the people involved in management of projects for street children decide what interventions were most needed and how to apply the funds allocated to them efficiently.

### 3.4 Population

The exact number of the Angolan population was unknown at the time this study was undertaken. Estimates were based on the 1970 census which was the last accurate survey conducted in the country. In 1980 a survey was conducted but its result was unreliable and it has not been published officially. The Angolan Institute of Statistics estimated that Angola had approximately 10 million people in 1995. More than 40 per cent of the population were children under the age of 15 years.

Information about the urban population was also uncertain. In 1970 the total population of Angola was 5 620 000 of which 15 per cent were living in urban areas (Bhagavan 1986). This picture was changed by independence and during the subsequent years of civil conflicts. Most of the Angolan population was concentrated in the cities with the majority being in Luanda. The ever increasing migration from rural areas to the cities combined with high birth rates made the cities grow quickly, whereas the infrastructures remained the same. Luanda for instance had in 1995 a water supply system designed to serve less than one million people whereas its population has grown from 1.2 million in 1983 to approximately three million by 1995. The construction of a new water supply system that would fulfill the increasing demands of a growing urban population was suspended a few years before independence. The new system would replace the existing one that was unlikely to operate satisfactorily after 1973. There was a project for a new hydroelectric dam being implemented. It was not clear whether the new project was requested by the government or whether it was imposed by the financier institutions. The context was not favourable for such a project, and as a result, its conclusion

has been delayed due to instability in the area of intervention. Many areas in Luanda were not supplied with canalized water and the residents of the areas served by such an out-of-date and over-utilized system were forced to use water sparingly.

Similarly, the drainage system in Luanda required upgrading. The sewerage discharged directly into the sea without any prior treatment. The system was initially designed only for drainage of rainwater. Each dwelling was supposed to be connected to a private septic tank. With time that purpose was simply ignored, and the same system was being used both for drainage of rainwater and for sewage from buildings. This factor, added to the poor supply of drinking water, was to some extent responsible for many diseases such as cholera and malaria which were very frequent in Luanda, especially in the rainy periods. There was another project in progress attempting to build treatment plants along the coast in order to collect sewage from all areas of the city to treat before discharging it into the sea.

The rural population was estimated to be approximately 85 per cent of the total population. Rural areas had a very low density of population with large areas of land without a single house. Most of the undeveloped land was rich in natural resources and was good soil for agriculture. However, this land has been used as battle fields and it was unexplored.

### 3.5 Culture

The Angolan people have diverse ethno-linguistic origins. Historians group them in eight ethno-linguistic groups corresponding to the following African languages most spoken in Angola:

- Fiote in Cabinda enclave;
- Kicongo in Zaire and Uige provinces;
- Kimbundo in the Centre-North and Centre-West parts of the country;
- Umbundo in the central region;

- Kwanhama in the South-West region;
- Nganguela in the South and;
- Cokwe in the Centre-East part of the country.

It was not possible to determine the predominant ethnic group in terms of numbers. It was supposed that the centre of the country was the most populous area which was predominantly "*Ovimbundu*" ethnic group. But this was not the case in the urban areas, where people from many different parts of the country were found. In Luanda, for instance, the original residents of the city, the "*Muxiluandas*" - an ethnic group of fishing people - did not constitute majority of the Luandan residents. Their economic activity gave them financial stability and relative economic independence even during the era of colonialism. This position helped them to maintain their culture and hegemony, and therefore the younger generations from these families were expected to follow their family traditions.

The majority of the population in Luanda were immigrant from different regions. Some of them settled themselves in the periphery and others were accommodated in refugee camp facilities. They were the ones who were more likely to lose their cultures of origin and street children generally came from these families.

## CHAPTER 4

### STREET CHILDREN IN ANGOLA

#### 4.1 Statement of the problem

In Angola, the phenomenon of street children was greater in Luanda and increased with the influx of newly arrived rural migrants (people from areas at war). Street children were observed in small numbers in the rest of the Angolan provinces. Cities in the Southern part of the country are more homogeneous than Luanda, even though this was the region most affected by the war. People of that part of the country are more likely to be mutually supportive and consider themselves as a family. Homeless families in the South of the country had been settled down in "*campos de deslocados*", a type of refugee camp, and children without parents were usually given to an "*Uncle*", an informal foster parent, that looked after them. Other cities in the North and interior of the country were too small (if not abandoned) and therefore street children did not exist there in appreciable numbers.

Facilities for street children were scarce. There were few NGO's and religious institutions in Angola who were working with homeless families. They helped homeless families with temporary shelters (mostly camping type facilities), food, clothing and health care. Occasionally private companies (national or foreign) donated goods for street children, or they engaged themselves in fund raising and collecting donations destined to help street children. A commission supported by an international NGO called '*Save the Children UK*', was created with the objective of locating and reuniting children and their families. Only in the second half of 1994, were the first shelters inaugurated in Luanda, and a radio station started a programme for fund raising destined to build a shelter for street children. This shelter would provide sleeping and eating arrangements. It will not include health care facilities.

Some of the existing shelters in Luanda had health centres for medical care of children accommodated

there. The major concern was however, the health care of children living in shelters without health centres, and children with no access to shelters. Sick children living in shelters without health centres were assisted by a doctor who went to these shelters on scheduled days, and those living on the streets were assisted by a mobile clinic. These facilities did not deliver adequate health care to them. The facilities were not available at certain periods when children needed services and there was no provision of sleeping facilities for sick children who were not living in shelters. Most children in these conditions sought health care to provincial hospitals in order to overcome the intermittent character of these facilities.

#### 4.2 Field work

Projects for provision of health care facilities require careful study of the particular needs of the different user groups during the planning stage, in order to achieve good results in the implementation of the project. The objective of the field work carried out in Angola was to determine:

- Deficiencies in providing health care to the street children;
- The special health needs of street children;
- The street children's attitudes to health care facilities and to other formal institutions, and;
- The feasibility of creating health care facilities exclusively for street children.

Most of the professionals interviewed during the field work in Angola were in favour of the idea of creating primary health care facilities for street children. According to their opinion, there was a need for health facilities with personnel awareness about the sort of users they would deal with. Others feared that it would promote home withdrawal among children. They supported the idea of promoting activities that would lead to the extinction of the street child phenomenon, such as family support, skills training and reintegration of children into their families.

Among street children, there was a widespread desire to get a place where they could find appropriate

sleeping arrangements and food. They looked forward to any programme aimed at improving their living conditions.

#### 4.2.1 Method

The study was conducted in two stages:

The first stage was carried out through bibliographical review of works discussing issues related to street children and through informal interviews with Social Workers and Doctors. It was conducted in Cape Town, South Africa, from February to August 1996. During this period the study was focused on determining whether or not there were precedents elsewhere for clinics or other health facilities dealing especially with street children; to gather information about the special health needs of the street children;

The search of references was conducted in all databases available at University of Cape Town (UCT) libraries except in the BIREMI database because of deficiencies of accessing this database through the INTERNET (a worldwide computer network).

Informal interviews were conducted with Doctors at Red Cross Hospital and at the Department of Public Health, University of Cape Town; interviews with Social workers were conducted at Department of Social Work, University of Cape Town and at institutions working with street children in Cape Town (Claremont Shelter and Streets Drop-In-Centre).

The second stage of the study was carried out through a field work in Angola from August to December 1995. From 28/08/95 to 07/10/95 the study was carried out in Luanda. The first two weeks were dedicated for interviews with the heads of institutions responsible for coordination of relief programmes destined to help people in situations of emergency in Angola, including street children. The objective

was to get information from these institutions about:

- Existing programmes both in Luanda and in other provinces;
- The location of facilities for street children;
- Places where street children gather and;
- A full list of institutions involved in the process.

The institutions contacted in Luanda were:

- Offices of international and Local Non-Governmental Organizations.
- Ministry of Social Reintegration (MINARSE).
- National Institute of Children (INAC)

Interviews with the principals of the existing shelters, as well as with the health representatives and social workers of these shelters, started in the third week. During the same period, interviews were also conducted with doctors. Appointments were made according to the availability of each person to be interviewed. This interviews were conducted with :

- Four shelters' principals;
- Six representatives of Non-Governmental Organizations dealing with street children;
- Four representatives of Governmental institutions (MINARSE offices in Luanda and Lubango, and INAC offices in Luanda and Benguela);
- Three Doctors at the Paediatric Department of the Hospital Maria Pia and at the National Health Office in Luanda.

At the same time preliminary contacts with children living on the streets were initiated with the help of social workers at one of the existing shelters (shelter "Centro da Praia do Bispo"). Visits were made

in the evenings and early mornings.

In the sixth week, interview forms were handed to the social workers of three shelters. These shelters were chosen because they were the closest ones to the places where the children gather. Interviewees were given explanations on how to fill in the forms and they were introduced to the objective of each question as well as the general objective of the survey. The children to be interviewed were selected randomly, both in the shelters and on the streets. Children living in shelters were interviewed by the Social Worker of the respective shelter, and children living on the streets were interviewed by the researcher together with a student of the fourth year of Architecture at University Agostinho Neto in Luanda.

One week was reserved for visits to three other cities (Benguela, Lobito and Lubango). Luanda and these three cities were considered by the local authorities as being the cities with the most street children in Angola. The objective of these visits was to observe in the field the situation of street children in other cities, and to complement the information obtained in Luanda. The institutions contacted in these cities were:

- UNICEF office;
- INAC office;
- MINARSE office.

In these cities, informal talks were also conducted with street children and other homeless people living in refugee camps.

The outcome of the field work highlighted two main factors. The first factor was that during the study the people to be interviewed used to postpone their appointments repeatedly with intervals greater than one week. The second factor was the children's eagerness for a solution to their principal needs. Some

children living on the streets did not want to respond to the questionnaire, alleging that they had been interviewed before but they had not seen any concrete solution. In many cases they felt disappointed after they were told that the study had mainly academic purposes.

Statistical records in Luanda were not available, all data was obtained through interviews. The data collected was coded and analyzed by computer with the help of the Department of Statistics, University of Cape Town. There were some gaps during the data processing either because of inaccuracy of some answers or because of unanswered questions. Quantitative data was, in some cases, based on estimations, non-numeric responses (such as "*many times*", "*few times*") were removed from the analysis for accuracy.

#### **4.2.2 Evaluation of the existing shelters**

Four of the seven shelters operating in Luanda were surveyed. Forms were designed in order to assess the quality of the facilities and services offered to street children. These forms were filled in during interviews with the principals of the shelters and afterwards visits of the facilities were conducted. Photographs of special aspects of the buildings were taken and some observations and important opinions that did not fit into the forms were recorded on tape for later processing.

##### **4.2.2.1 Number of shelters and period of their existence**

The National Institute of Children in Angola (INAC) estimated that 20 shelters were required in order to accommodate all street children in Luanda. By the date of the interviews, there were 7 shelters in operation and 2 under construction. The oldest of the shelters surveyed had been operating since August 1994. All shelters were filled on the date of inauguration. Since then, only children referred by members of an institution or organization working with street children have been admitted at some shelters.

#### **4.2.2.2 Location**

Shelters for street children were located at the periphery of the city. The distances from the city centre, where the great number of street children were found, to the places where shelters were located, range from two to five kilometres. The areas where these shelters were located were either predominantly residential (Futungo and Palanca suburbs) or industrial (Petrangol and Viana suburbs).

#### **4.2.2.3 Programme and services provided**

The common features of the shelters in Luanda were the sleeping areas, eating areas, recreation areas, and toilet facilities. One of the shelters surveyed did not have a kitchen incorporated. Its food was being prepared at the sponsor company's kitchen. There were two shelters without health centres and they had to rely on external health facilities. Sick children at these shelters had been taken to provincial hospitals under supervision of the shelter's staff, or a doctor had been to these shelters on scheduled days for medical consultations.

Education and training facilities were only available at one shelter, which had classrooms and workshops. Other shelters had their children registered at normal schools.

#### **4.2.2.4 Type of construction**

Amongst the shelters surveyed there were two types of construction:

The most prevalent type was based on modern architecture using low cost materials. These buildings were made of plastered brick walls with paint finishes, and had ridge roofs which were made of fibrocement sheets. There were three shelters in this category. However, two of these shelters were buildings that were initially designed for a different purpose. One occupied the building of a bankrupted

governmental building company, and the other had hired two wings of a budget holiday accommodation facility.

The second type of construction was observed at one shelter. This was a temporary facility based on tents and containers.

#### 4.2.2.5 Capacity

The shelters surveyed had accommodate 525 altogether with an average of 60 children per shelter (highest 350 children). This number represented 81.7 per cent of all street children living in shelters which was approximately 642 children. The number of children living in shelters was about 16.05 per cent of the total estimated number of street children in Luanda.

There were no plans available at the shelters surveyed neither were their principals able to give information about the dimensions of the different areas of their institutions.

The number of children accommodated in each shelter were:

Palanca Shelter	- 350 children
Futungo Shelter	- 65 children
Tecnocarro Shelter	- 60 children
APV Shelter	- 50 children

At the time of the survey, none of the shelters had space available to admit new children. Moreover, the principals stated that the number of children accommodated was over the real capacity of the shelters.

#### **4.2.2.6 Funding**

All shelters were run on a non profit basis. These shelters were integrated in the emergency programme aimed to help people at war. It was also part of the governmental programme for social reintegration. They were being funded mainly by international Non-Governmental Organizations, and by local private companies. The Government Institutions were dedicated mainly to policy making, planning and coordination. However, the Government had a funding programme called "*Social Development Fund*" (discussion with ONAM 1995) available for all social and/or economical development projects.

#### **4.2.2.7 Intake Criteria**

Children living in shelters were assessed prior to their admittance to a shelter. Social Workers made contact with children on the streets. Those children that showed better capacity of adaptation to institution life were selected and were offered a place in a shelter. In all shelters most of the children had been living there for more than six months.

#### **4.2.2.8 Deficiencies**

Problems varied from one shelter to another. A common problem was the insufficiency (or lack in some cases) of medicines. A principal of one shelter considered the existing store and dressing rooms as inadequate, and thought that the shelter needed a staff area. Another principal had as a main concern the lack of a health centre and transport.

#### **4.2.3 Mobile clinic**

The mobile clinic was an ambulance that had been going to different points in town from Monday to

Friday evenings. The ambulance was operating with two Nursing Sisters and two Social Workers.

There was one mobile clinic operating in Luanda. It started operating in September 1994 with the objective of providing curative care and counselling to the street children who were not living in shelters. Children in need of special care were being taken to the provincial hospitals where the mobile clinic staff supported them with food and medicine.

The mobile clinic failed due to the fact that it was not always available when it was needed. Also, it had limited capacity and limited range of services on offer. It was considered to cover approximately ten per cent of the street children's health needs (according to one of the mobile clinic's social workers).

Also, the costs of operation and maintenance were considered to be expensive, especially for a country which was not a manufacturer of such technology.

#### **4.2.4 Communal kitchens**

Communal kitchens were open air spaces where food was prepared and served to needy people. These type of facilities were destined for all refugees. Communal kitchens were more common in other provinces than in Luanda.

#### **4.2.5 Opinion of the professionals working with street children**

##### **4.2.5.1 Shelters' principals**

At the time of the interviews, shelters in Luanda had been operating for about one year. Most people working with street children stated that they had had little experience of dealing with street children previously.

Three of the principals supported the idea of building health centres for street children. According to them, these health centres would serve both children living on the streets and children living in shelters. They were of the opinion that it would enable them to refer their children to such centres, instead of using provincial hospitals where the staff were not prepared to deal with street children.

Another principal supported the idea of integrating these facilities into communal health centres. According to this principal, all primary health centres should be upgraded in order to improve the health care delivery for entire communities, instead of looking only at the street children's needs. The process of upgrading the community health centres would include the provision of special areas in the centres specially for street children, according to the same principal.

#### 4.2.5.2 Government institutions

There were three groups of opinions amongst the representatives of Governmental institutions:

Non-institutionalization of street children's facilities;

Comprehensive programmes and;

Those who considered the street children to be the same as any other human being.

Non-institutionalization reflected the opinion of those who thought that creation of street children's facilities would stimulate the desire of children to leave home, and that underprivileged parents would encourage their children to go to the streets. They argued that some children had better conditions in shelters or even on the streets than at home or at a refugee camp, and that the number of street children had been increasing since welfare programmes started. *"A boy that washes cars earns more than his father working at a state company"* said one of them, and that *"Many cases of adoption processes have been cancelled because parents claimed their children. They feared to lose their children forever. It shows that some children living in orphanages are not true orphans"*.

The second group were those who considered the development of programmes aimed at the street children necessary. They were of the opinion that it was opportune to create a network of institutions providing comprehensive services for street children, such as shelters, feeding schemes, health care centres and, education and recreation facilities.

The third group were mainly Doctors who were interviewed. They said that they were not concerned with the nature or origin of their patients, and therefore, they dealt with street children in the same way as they dealt with any other patients.

#### **4.2.5.3 International Non-Governmental Organizations**

Funding programmes were the major concern of the international NGO's which were operating in Angola. They were helping the local NGO's and the state institutions in funding relief-programmes. They stated that they would support any programme that proved to be feasible. In most cases, the opinions of the international NGO's were confirmations of the opinions of the local institutions which constituted their main partners.

#### **4.2.5.4 Proposed improvement**

The suggestions for improvement of health care delivery to the street children had trends of suggesting the improvement of the health system in general. They proposed, among others, the following interventions:

- Staff Training in order to increase awareness about the special needs of the street children;
- Upgrading of the existing communal health centres;
- Improvement of the social conditions of the medical and paramedical staff;
- Provision of the essential drugs and supplies at hospitals and primary health centres;

- Promotion of public education programmes;
- Creation of comprehensive services for street children.

#### **4.2.6 Assessment of the actual health care delivery to street children**

Current health care delivery was considered to be inappropriate not only for the street children, but also for the rest of the community. The low salaries and poor living and working conditions of the medical staff, scarcity of the essential drugs and supplies were, among others, the reasons that were considered to contribute to the bad quality of service given at the existing primary health centres and at the provincial hospitals. As a consequence of this situation, street children living in shelters without a health centre, and those living on the streets, did not have appropriate access to health care.

#### **4.2.7 Suggested location of the street children's health centres**

Most professionals suggested as the location for facilities for street children (including health care facilities), places near to the city centre where street children customarily work and sleep. The obstacle, however, was that most of the unoccupied sites had been sold to private individuals. On the other hand, there were still many people that viewed street children as an inconvenience in the city centre. These people would oppose the approval of applications for building street children's facilities on sites in the city centre.

## **4.2.8 Results of interviews with street children**

### **4.2.8.1 Sample**

The total number of children interviewed both in shelters and on the streets was 177. Of this number, 137 children were interviewed from the 12<sup>th</sup> of September to the 10<sup>th</sup> of October 1995, and 40 children were interviewed from the 13<sup>th</sup> to 21<sup>st</sup> of December 1995. In the second series, interviews were conducted only at areas where children were not interviewed during the previous sessions. The objective was to avoid interviewing the same children more than once. However, during the data processing stage, coded data was checked and five repeated entries were detected and deleted from the database. The final sample considered was of 172 street children. Of this number 112 children were living in shelters, 58 were children living on the streets and 2 children with unknown living places

There was an estimated total of 4000 street children in Luanda (discussion with INAC 1995). Of these, 1300 were thought to be children "of" the streets, which was the group to be studied. The sample considered represented 12.9 per cent of the total population to be studied.

### **4.2.8.2 Age and sex**

The children interviewed were all male. Street girls were mostly in foster care and others were children "on" the streets, and therefore, were out of the scope of this study. The age ranged from 5 to 18 years old, with a mean age of 13.02 years. The children interviewed in shelters were on average older than the ones interviewed on the streets. The mean age of the children interviewed in shelters was 13.4 years old with age ranging from 9 to 18 years old. The mean age of the children interviewed on the streets was 12.2 years old and their age ranged from 5 to 17. Amongst children interviewed in shelters, the most frequent age was 14 (represented by 26.8 per cent) and for their counterparts on the street, the most frequent age was 12 (represented by 24.1 per cent).

Table 1 - Proportions of street children in Luanda according to their origins.

ORIGIN	LIVING PLACE						TOTAL	
	IN SHELTERS		ON THE STREETS		NOT SPECIFIED			
	Nr	Percent	Nr	Percent	Nr	Percent	Nr	Percent
Other provinces	61	54.46	49	84.48	1	50.00	111	64.53
Luanda	40	35.71	7	12.07	1	50.00	48	27.91
Unknown	11	9.82	2	3.45	0	0.00	13	7.56
TOTAL	112	100.00	58	100.00	2	100.00	172	100.00

#### 4.2.8.3 Origin

The children interviewed came from 13 different provinces of the total 18 provinces. Luanda was represented by 27.9 per cent (48 children), 64.53 per cent came from other provinces and 7.6 per cent were children of unknown origin. Of the children interviewed in shelters 54.5 per cent were children from other provinces, 35.7 per cent were children born in Luanda and 9.8 per cent of unknown origin. Of those children interviewed on the streets 84.5 per cent were children from other provinces, 12.1 per cent born in Luanda and 3.4 per cent of unknown origin.

There was not a perceptible relationship between the origin of children and their preference for living either on the streets or in shelters. The principal factor was the lack of space in shelters, which left children with no alternative but to live on the streets.

Children from other provinces came mostly from provinces affected by war in the late 80's and early 90's such as Malanje, K. Norte and Uige. During that period, transport from these provinces to Luanda was secured by international NGO's.

#### **4.2.8.4 Schooling**

More than 70 per cent of the children interviewed both in shelters and on the streets had not concluded the 4<sup>th</sup> year of schooling. 6.4 per cent had never been at school.

#### **4.2.8.5 Access to Health Care**

The health status of street children in Luanda was in general weak. Children were asked if they had been sick during the past six months to the date of interview. 137 children (79.7 per cent) had been sick. Of these children, 32 had not visited a health facility or seen by any physician, and 34 had been refused admission to a health facility at least once.

The proportion between the children that had been sick and the children that had not been sick amongst the children interviewed in shelters, was not very different amongst the children interviewed on the streets. The proportions were respectively 80.4 and 79.3 per cent.

Table 2 - Visits to health facilities

	Had been sick		Had not been sick		Total	
	Nr	Percent	Nr.	Percent	Nr.	Percent
Children that had visited a health facility	100	58.14	1	0.58	101	58.72
Children that had not visited a health facility	32	18.60	29	16.86	61	35.47
Not specified	-	-	-	-	10	5.81
TOTAL	132	76.74	30	17.44	172	100.00

Places where children went for treatment were mostly the health centres attached to shelters (80 cases), and the provincial hospitals (29 cases). Provincial hospitals tended to be more visited by children living on the streets (15 per cent) and the health centres attached to shelters tended to be more used by children living in shelters (54.3 per cent). Other facilities used by the street children were: the mobile clinic (6.4 per cent) and community health centres (1.4 per cent).

The frequency of sickness per child was on average 3.02 times. 48 per cent of the total number of children interviewed had been sick three times or more (mode 5 times), which meant that each child had been sick at least once, every two months.

Table 3 - Frequency of sickness

TIMES OF SICKNESS	IN SHELTERS		ON THE STREETS		TOTAL	
	Number	Percent	Number	Percent	Number	Percent
Once	15	12.0	13	10.4	28	22.4
Twice	27	21.6	16	12.8	43	34.4
Three times	11	8.8	4	3.2	15	12.0
Four times	-	-	3	2.4	3	2.4
Five times and more	29	23.2	7	5.6	36	28.8
TOTAL	82	65.6	43	34.4	125	100.0

Table 4 - Health facilities used by street children

PLACE OF TREATMENT	IN SHELTERS		ON THE STREETS		TOTAL	
	Number	Percent	Number	Percent	Number	Percent
Shelter's health centre	76	57.1	3	2.3	79	59.4
Provincial hospital	8	6.0	21	15.8	29	21.8
Health centre	1	0.8	1	0.8	2	1.5
Mobile clinic	-	0.0	5	3.8	5	3.8
Others	2	1.5	7	5.3	9	6.8
Did not bother	-	0.0	9	6.8	9	6.8
TOTAL	87	65.4	46	34.6	133	100.0

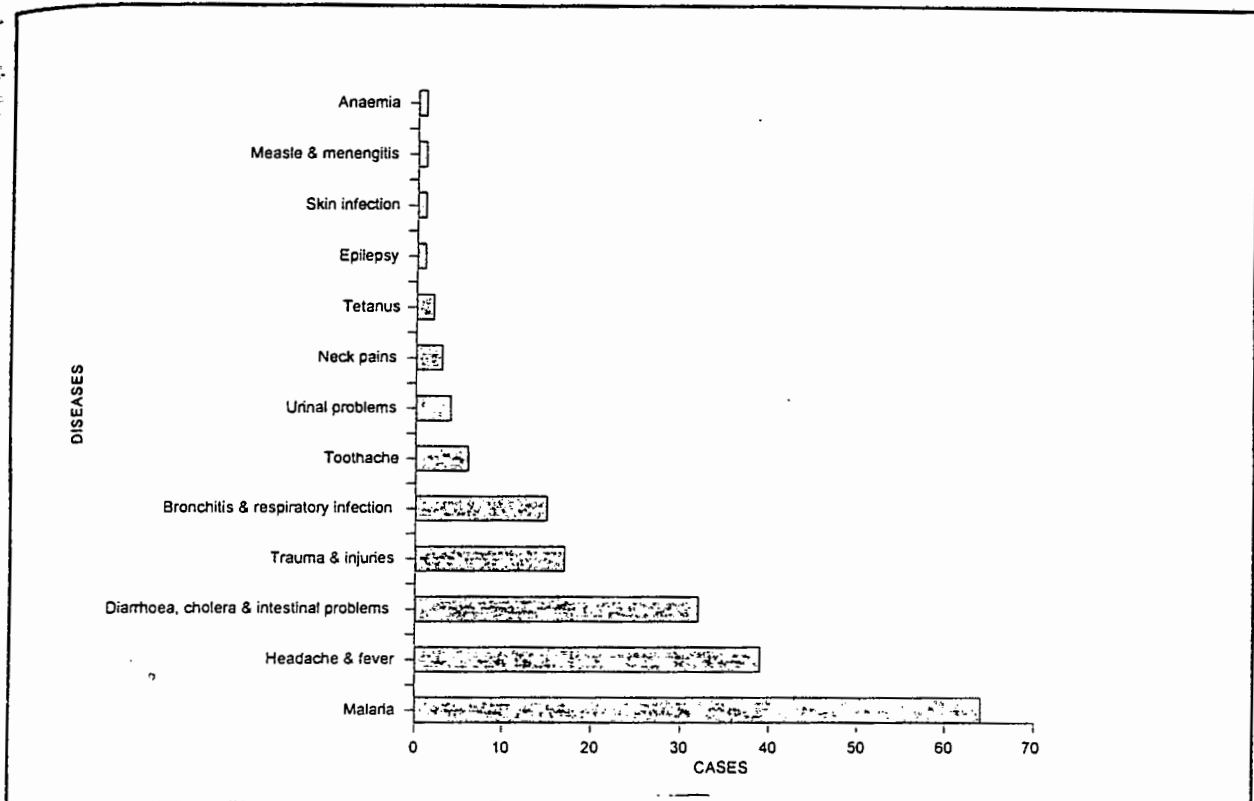

Fig. 1 - Frequency of diseases

#### 4.2.8.6 Types of diseases, period of cure and place of convalescence

The types of diseases most frequently observed were infectious diseases, which were linked to poverty in general and inappropriate sanitation in particular. The most observed diseases in the sample considered were:

- Malaria with 64 cases;
- Headaches and fever with 39 cases;
- Cholera, diarrhoea and other intestinal problems with 32 cases;
- In addition trauma and injuries were also high, with 17 cases.

The length of the period of cure varied according to three factors: place of treatment, place of convalescence and type of diseases.

- Place of treatment - children were more likely to go to a hospital or to a shelter's health centre for diseases with periods of cure equal or longer than seven days. the mean was 5.1 days for children interviewed in shelters and 3.9 for children interviewed on the streets.
- Sleeping place - sleeping places were linked to places of treatment, i.e. children slept at a shelter or at a hospital, if they were treated at these places. For these cases, the length of period of cure was mostly seven days or more.

Children slept on the streets when they were treated at a community health centre, mobile clinic or if they did not have any treatment at all. This tended to be for minor diseases and the length of period of cure was less than three days in most cases.

- Types of diseases - the types of diseases with the highest length of period of cure were: malaria, cholera, diarrhoea and other intestinal problems. The period of cure was on average 5.0 days for cases of malaria. Cases of cholera, diarrhoea and other intestinal problems the length of the period of cure was on average 4.2 days. These diseases were also the most frequently observed.

Table 5 - Correlation between type of diseases and sleeping place

DISEASES	AVERAGE PERIOD OF CURE			
	Streets	Shelter	Hospita	TOTAL
Headaches and fevers	3.6	2.7	5.1	3.6
Cholera, diarrhoea and other intestinal problems	3.1	4.6	6.0	4.2
Malaria	4.5	5.0	5.5	5.0
Trauma and injuries	5.2	4.2	6.5	5.5
Toothaches	7.5	6.2	1.5	5.5
TOTAL	4.78	4.54	4.92	4.76

#### 4.2.8.7 Attitude towards health facilities

Of the 172 street children interviewed, 50 per cent considered the services offered at the existing health facilities (big hospital and primary health centres) as good, 11 per cent as average and 6.5 per cent considered them as bad. This tendency was because of the composition of the sample. Children living in shelters were taken to these hospitals by the shelter's staff and therefore they were helped better than those that went alone. This was the reason why among sheltered street children, 53.4 per cent classified the services offered there as being good, 31.0 per cent as average and 6 per cent as bad. However, of the children that had been refused admission to a hospital 17.3 per cent were children living in shelters and 31.6 were children living on the streets. The reasons given by others were lack of medicines in 11 cases, 4 cases because the facility was full and 2 cases because they went alone.

A health centre just for street children would be the mostly preferred health facility. It was wanted more by children interviewed on the streets than by children interviewed in shelters. 51.7 per cent of the children interviewed on the streets answered that they would prefer to use a health centre just for street

children, whereas amongst children interviewed in shelters only 30.4 per cent had the same preference. This last group of children favoured the health centre incorporated to a shelter (35.7) whereas children interviewed on the streets only 6.9 favoured this type of health facility.

Table 6 - Preferences per type of health facility among street children in Luanda

PREFERENCES	IN SHELTERS		ON THE STREETS		TOTAL	
	Number	Percent	Number	Percent	Number	Percent
Health centre just for street children	34	22.7	30	20.0	64	42.7
Shelter's health centre	40	26.7	4	2.7	44	29.3
Provincial hospital	19	12.7	10	6.7	29	19.3
Community health centre	6	4.0	7	4.7	13	8.7
TOTAL	99	66.0	51	34.0	150	100.0

#### 4.2.8.8 Diet

Children living in shelters had regular meals, both in number of meals per day, and in quality. These children had three daily meals and their diet was based on rice and maize porridge.

Children interviewed on the streets were more likely to have irregular meals. More than 60 per cent had less than three meals per day. They got food from the vicinity, the street workers or they bought it themselves. However, the type of food that children interviewed on the streets ate, was similar to that of children interviewed in the shelters

#### 4.2.8.9 Problems

As found by previous researchers, the primary concerns of the street children in Luanda were also shelter and food. Health care, education and entertainment constituted secondary priorities for them.

When asked about their main problems of keeping themselves healthy, 31.4 per cent were concerned about their personal hygiene, 20.4 per cent were concerned about inappropriate health care and lack of medicine, and 16.3 were concerned about inappropriate diet.

#### **4.2.8.10 Opinion on the creation of a health care centre exclusively for street children**

86.6 per cent of the children interviewed both in shelters and on the streets were in favour of creating a health centre just for street children. 102 (59 per cent) were children interviewed in shelters and 45 (26.2 per cent) were children interviewed on the streets.

#### **4.2.8.11 Proposed location**

Children interviewed in shelters were more likely to suggest places near to shelters, and those interviewed on the streets preferred sites in town, where street children usually gather. In both cases children had a tendency to suggest sites near to places where they were living.

#### **4.2.9 Summary of the health care problem relating to street children in Angola**

- Location of health facilities: Shelters which had built in health centre were located in areas far from areas where street children concentrate and therefore, they were not easily accessible on foot.
- Availability of health facilities: the number of shelters with built in health centres was not sufficient in order to accommodate and provide medical care to all street children in Luanda. No provision of special services has been made at community health centres or at provincial hospitals in order assist street children. They were dealt with in the same way as patients who had homes and who had family support.
- Non comprehensive character of services offered at the existing health facilities: health services offered at shelters, community health centres and mobile clinic have not addressed simultaneously the medical, sleeping and eating needs of children which had no access to

shelters. Shelters and community health centres addressed the needs of specific groups of users which were not compatible with the needs of the children living on the streets; the mobile clinic provided medical care only. It has not addressed the need for improvement of sleeping and eating conditions.

- Diet: street children in Luanda had a poor and irregular diet. This status associated with the poor quality of drinking water, bad personal hygiene and ignorance of basic measures of sanitation had as a consequence increased the risk of contracting infectious diseases, weaken their immunization capacity and delayed their convalescence.

## CHAPTER 5

### HEALTH FACILITIES

#### 5.1 Street children's problems in regard to facilities

The review of international literature revealed interest in giving only shelter and food to the street children. There were shelters, soup kitchens and other similar facilities that provided mainly sleeping arrangements and food. The health care of street children had been highly neglected or it had not been properly delivered. Most of the existing health facilities were designed for homeless people in general and these facilities were usually located in the vicinity of shelters for homeless people. There were few facilities directed exclusively for delivery of health services to street children. These facilities were found in Toronto, London, Tegucicalpa, Melbourne, Seattle, New York and Los Angeles. In most other cities street children were generally assisted at shelters that had health centres or at community health centres.

The following are the types of health facilities for street children which were found during the review of international bibliography:

- Mobile vans - this type of health facility was found to be operating in London and Toronto (Gebbers 1990). They intended to address street children's health needs by going to places where these children gather.
- Health centres attached to a shelter - these were small health centres built in shelters and they were the most common types of health facilities for street children globally. These health centres mainly assisted children living in the associated shelter.
- Clinics for street youth - they existed in the USA. These clinics have been giving free health care to street youth in the evenings (Sherman 1992; Deisher 1991 et al.). A similar centre

exists in Melbourne, Australia, as part of a community health centre which gives services to the street children. It provided four hour evening services, once a week (Wales 1991). In Latin America, only Honduras was found to have developed a health programme for street children. The programme called "*Proyecto Alternativos*" had six sites in Tegucigalpa with five of these sites located in open-air markets (Wright 1993b). No description of the physical characteristics of the facilities was available. The "*Proyecto Alternativos*" aimed at providing primary health care on-site and had as its principal activities: first aid, curative care, assessment, counselling and prevention.

In general terms, facilities and services directed at street children were basically of two types: prevention and rehabilitation services.

- Prevention - prevention programmes are interventions directed at the causes of street children. They included working with the communities where street children came from and their families, in order to determine the causes and find methods of prevention. They also included working directly with children on the streets in order to build trust. Data collection and research were also part of the programmes.
- Rehabilitation - rehabilitation programmes are interventions directed at working with street children in order to prepare them for reintegration into society or to reunite them with their families and communities.

These interventions were implemented through:

- Street work - this was being done by social workers who went on the streets and made contact with street children.
- Drop in Centres - these were non-residential facilities where children went for food, and where bathing, clothes washing and recreation facilities were available.

- Shelters - these facilities offered comprehensive services to street children. They generally included sleeping arrangements, food, health care, education and recreation.

Other facilities, although with the objective of helping street children, were found to be unsuitable for the street children's life style. Brazil, for instance, the country with the most street children in Latin America, had developed state institutions for the welfare of children called "*FEDEM*" or "*FUNABEM*", initials from "*Fundacao Nacional do Bem do Menor*" in Portuguese, which means '*National foundation of child welfare*'. These facilities had almost the same characteristics as the "*Places of Safety*" in South Africa. Children were removed from the streets for re-education, and they were forced to live locked in institutions for indeterminate periods of time under poor living conditions whilst suffering ill-treatment (Scheper-Hughes 1994). Brazil was also strongly accused of having developed death squads responsible for the disappearance of street children.

## **5.2 Definition of the type of health facilities required**

### **5.2.1 General considerations**

Special primary health centres separated from shelters would be the option which would fulfill the health requirements of street children in Angola. The assessment of the existing health facilities for street children in Luanda (health centres attached to shelters and a mobile clinic) have shown that these facilities did not meet the needs of all street children. Children living on the street had no access to health centres at shelters and the mobile clinic was not permanently available.

The evaluation of the community health facilities in Luanda and the health system in Angola in general was unfavourable to health care of street children. The desperate need to find alternative sources of income in order to balance the low salaries of governmental companies' employees have made health care services very expensive in Angola. Even though health care services at governmental hospitals were supposed to be free of charge, patients had to buy medicines and pay medical practitioners informally in order to obtain reasonable services.

Attitudes of street children towards health facilities showed evidence that they were not suspicious of formal institutions and that they would prefer to use specialized facilities.

The guidelines and the case study presented in this study give an array of information for designing health care facilities for street children in order to meet the following conditions:

- The design of functional facilities which meet the special health needs and characteristics of street children;
- Design of well integrated health care facilities for street children which allows easy access from areas where these children concentrate and from existing facilities serving them;
- Creation of facilities with flexible spaces allowing eventual conversion to areas having different purposes from which these spaces were initially designed for.
- Creation of multi-functional spaces which allow the same spaces to perform different functions simultaneously or during different periods;
- Creation of low cost facilities through careful selection of sites, construction materials and medical equipment which are found to be financially viable and technically appropriate;
- Creation of health facilities adapted to the different economic, technological, climatic, topographical and urban features of specific contexts.

Although this study was based on information obtained in Angola, guidelines can be used and adapted for designing health facilities for street children living in similar condition as the street children in the Angolan context.

## 5.2.2 Functions

The primary health care facilities for street children are proposed to include the following services:

- Basic treatment of common health problems of street children;
- Prevention of infectious diseases;
- Health education;
- Promotion of basic sanitation and personal hygiene;
- Counselling and;
- Temporary sleeping arrangements and food supply during convalescence.

## 5.2.3 Climate considerations

During hot seasons in Luanda, temperatures vary from 24 to 31 °C, and during cold seasons temperatures vary from 18 to 29°C. Relative humidity is above 70 per cent throughout the whole year. The limit of comfort for this level of humidity is between 22 to 27°C. Therefore, it is necessary to cool and dehumidify the interior of buildings in order to achieve acceptable levels of comfort.

In these climatic conditions, cross ventilation is essential in all areas of the health centre. Long façades should be orientated to North and South directions and they should be protected against direct solar incidence. However, orientation should be adjusted to the direction of predominant wind which is South Westerly in Luanda. The long axis of the building should be rotated 15 degrees clockwise to the South West direction (see fig 2), in order to balance sun incidence and air flow inside the building. Buildings in Luanda with this orientation get sun during some period of the day and they are easily protected with shading devices, overhanging roofs and verandas. The desired velocity of air flow in interiors of buildings can be regulated through the size of openings which are usually between 40 to 80 per cent of the wall area. The openings in the windward direction should be smaller than the ones at the exit side in order to increase the velocity of the indoor air.

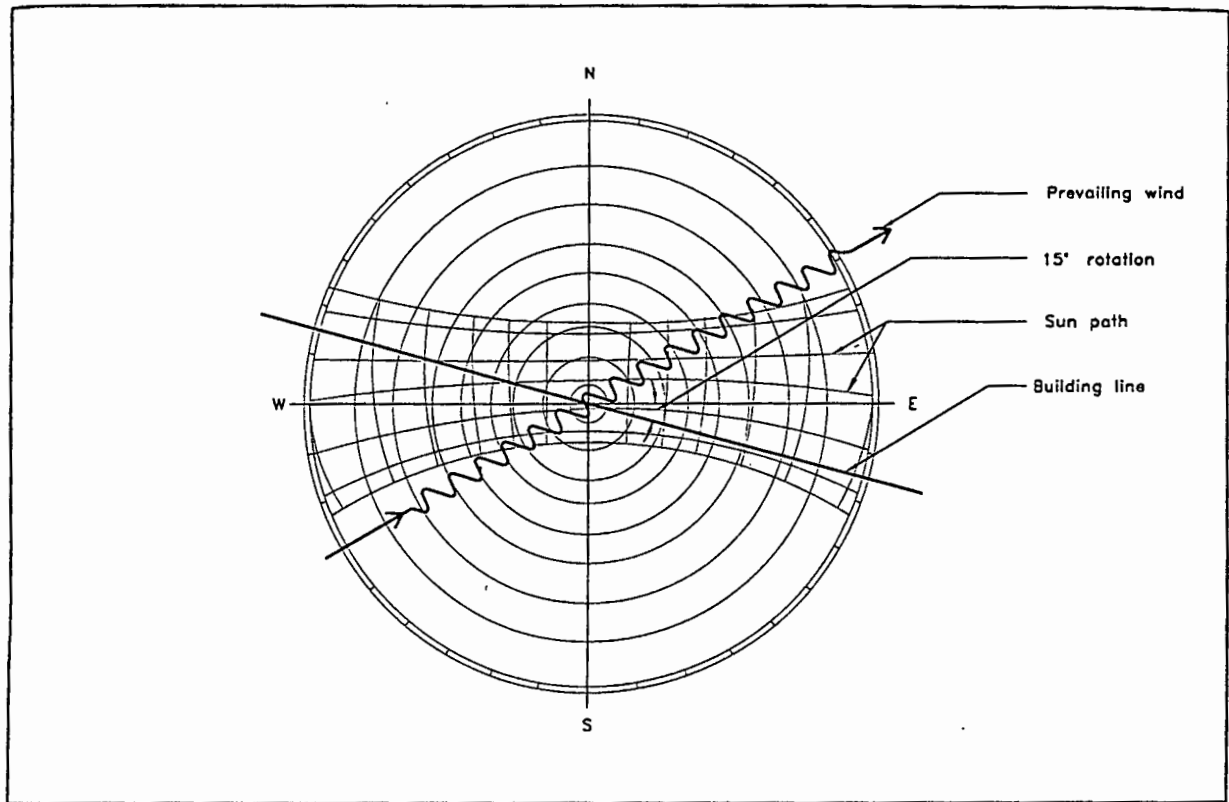

Fig. 2 - Solar diagram showing recommended building orientation in Luanda.

Cities in the interior of the country have moderate temperatures. There, ventilation is desirable during the hot season. However, heating is necessary during cold seasons. Shading devices for buildings in these regions should be adjustable, and buildings should be orientated in such a way as to balance sun incidence and wind direction with the objective of protecting buildings against excessive heat during hot seasons and allowing the sun penetrate into buildings during cold ones.

In hot climates, roofs should be designed with two layers separated by a ventilated space. Water proofing must be carefully considered in cities in the interior where rainfalls are heavy in some periods of the year. Pitched roofs should be given preference to flat ones and their slopes should be well studied. The construction, water proofing and maintenance of fibrocement pitched roofs are cheaper than concrete flat roofs. This last type requires more specialized technicians and imported materials.

### 5.3 Primary health care facilities for street children

#### 5.3.1 Objectives

The primary health care centres for street children are intended to perform the following tasks:

- Give basic medical assistance to street children, complemented with partial in-patient services (sleeping and eating facilities).

The principal objective of these health centres is the integration of specialized health facilities for street children into the traditional health care delivery systems in Angola, in order to assist those children with no access to shelters and those living in shelters which have no built in health centres. They are also proposed to serve as a second resort for shelters with built in health centres before children are sent to provincial hospitals. These health centres should also assist children from families living below the acceptable level of poverty, especially in cities such as Luanda, where people have few alternatives to choose the type of health facilities where they can seek health care. Services for these children would be charged at low rates as a means of fund raising for operation of the health centres.

- Serve as a means of approaching children in order to build trust and encourage them to use specialized facilities;

The fact of making health care facilities available should be complemented with constant health education. There are also some non-street children who seek health care facilities in cases of terminal diseases only. Street children are not isolated from the cultures of the community where they come from. In addition to suspicion, there are other factors which may make street children reluctant to seek health care at an early stage (sociocultural and economic factors).

These centres should be used as means of introducing children to the advantages of diseases prevention; as means of showing them how accessible and affordable health care is, if they use the right facility; and how they would benefit by using the various services offered by other institutions for street children.

- Provide facilities for training and research on the field of health care of street children.

Research on street children is not yet well documented in Angola. These centres could be used by medical students for training and research in the field of health care for street children. Medical students in training could act as a philanthropic team which would help in reducing costs for medical staff at these centres.

### **5.3.2 Criteria for location of health centres for street children**

The access to health care is conditioned to three factors : availability, geographical distribution and financial capacity of users (Joseph 1984).

- Availability - the number and capacity of facilities provided which is able to cover the needs of all prospective users.
- Geographical position - the location of facilities in areas where the distances to every potential sources of users are balanced.
- Financial capacity - the affordability of users to pay for the services which the facilities provide.

Health facilities should be available and distributed according to the different needs of all members of the community for which the facilities are intended to serve. The facilities must be able to deal with the most common diseases of all social stratum, age groups and genders. Street children constitute a particularly difficult group of people because of their health attitudes. As discussed in previous chapters, most of them tend to neglect their health for various reasons. One of these reasons is that

street children consider health care as a second priority in their lives, and most of them work even when they are sick. Health facilities for street children should be made as accessible as possible. They should be located within a radius which allows easy access, with special reference to travel time and costs of transport. When designing health facilities for these children, geographical distribution is a key factor to be considered in order to guarantee access.

Street children are usually found near to the city centres, traffic lights, shopping centres and tourist places. They find in these places what they need for their survival activities: guarding and/or washing cars, begging, shoe shining, selling goods, petty crime etc. (Ennew 1986 et al.) The selection of sites should be made taking into consideration the distances of such areas from the existing facilities offering services to street children. Health centres for street children should be located within short travelling distances from places where street children work, sleep, or concentrate for meals or entertainment. The travel distances should be within thirty to forty five minutes walking time, or within a radius of 400 to 800 metres (Engelhardt 1956). If shelters without health care facilities could send their children to these centres without needing a means of transport, it would be advantageous in order to reduce costs.

However, unoccupied sites are usually scarce in city centres. Therefore, the proposed health centres for street children could be either new buildings or old ones converted into health centres. Community health centres located in areas accessible to street children could be adapted by including sleeping and eating arrangements in them. The community health centres adapted to deal with street children would assist these children in the evenings and other members of the community during the day.

### 5.3.3 The user group and their requirements

During the field work in Luanda, street children reported health problems related to bad sanitation, poor quality of drinking water, inappropriate diet and accidents. The most frequent ailments were malaria, fever, intestinal problems and injuries. The length of period of convalescence was on average 4.8 days. There were cases where the period of convalescence was more than seven days. According to medical studies (Spring-House 1995; Dhiman 1992), patients with diseases like malaria, cholera and diarrhoea under proper medical care take 2 to 4 days for complete recovery. Street children in Luanda had such long periods of recovery from sicknesses because of inappropriate health services, their weak resistance due to undernourishment and instable climatic conditions in places where they slept. It is necessary that treatment takes place under proper conditions in order to achieve efficient results. For instance, people exposed to damp and cold conditions were more likely to develop respiratory infections. Health conditions of patients with such problems would deteriorate if they remained in the same environment during treatment. Diarrhoea and cholera are water born diseases which cause dehydration. The treatment of these diseases require replacement of the lost liquids in the body. Liquids for rehydration should be free of the pathogens which cause such diseases. However, good quality of water can not be guaranteed, if during treatment, children use the same source of water supply as the one they were using at the time they were infected.

Abuse of solvents and alcohol is common practice among street children on their attempts in coping with the stressful street life. Psychological disorders have negative influences to physical well being. Therefore, primary health centres for street children should give attention to alcohol counselling and drug detoxification. Children should be taught to cope with stress without turning to stimulants. Older street children should be introduced to measures of safe sex practice for prevention of sexually transmitted diseases.

Street children get consumers during office hours, when shops are open, parking is full and traffic is intense. This is the most profitable period for their survival activities. In the evening, only those children

involved in evening jobs and those involved in criminal activities are busy. Most of them are free during this period. Evenings are, therefore, the appropriate periods for the operation of health facilities for street children.

Other aspects are the proportion between street boys and girls, the age range, and the poor health appearance characteristic of street children.

Female street children are few in proportion to boys. In Luanda, for instance, children living on the streets were mostly male. Female children were usually in foster care or at refugee camps under supervision of adults. On the other hand, street children share the same spaces on the streets, and they would stay at these centres for a relatively short period of time. Luanda would require the provision of more health facilities for boys than for girls.

The ages of the street children interviewed ranged from 5 to 18 years old. Those over the age of eighteen years old would not require the same care as the younger ones. Health facilities for street children can not be conceived as paediatric health centres. Their spaces should be designed, and their equipment selected in order to fulfill the requirements of both children and adults.

Due to the fact that street children's poor health appearance helps them with begging for money, food or other goods, they might not look for health care. Hence, the need for co-operation with social workers in making constant contact with children on the streets, informing them about the existence of these centres and encouraging them to make use of such facilities. It should be done in conjunction with other institutions and professionals working with street children.

#### 5.3.4 Size and number of units required

Size in the system of classification of health facilities usually refers to the number of beds the facility has. A health facility with an ideal number of beds for its size (local, provincial or national), should have all beds occupied every day without having to deny admissions to new patients due to the insufficient number of beds. This status of equilibrium is only achieved if the number of patients leaving the facility on a certain day is equal to the number of patients admitted. If there are more patients leaving the facility than those admitted, the number of unoccupied beds increases. On the other hand, if there are more patients admitted than patients leaving this number decreases. The first hypotheses would lead to a critical stage where the health facility would be left without any internal patient, and the second hypothesis would lead to a stage where the facility would have no available beds for admission of new patients. A well planned health facility should balance these two critical situations. It is, therefore, necessary to review the medical history of the population and to determine their attitudes towards stay in hospitals. The data collected would be used in determining average admissions per day, average length of stay, future trends and the impact of the planned facility on the actual situation.

The size and quantity of health centres for street children required are determined by the number of street children to be served, the frequency of sickness and by the average period of convalescence (period of permanence at the centre). Such as any facility for street children (discussion with social workers in Cape Town), health care centres for street children should be of reduced capacity in order to allow better follow up of children. It is also appropriate for better geographical distribution. The capacity of these centres should be up to fifteen beds. In cases where the total number of beds required is higher, it should be subdivided into various centres which satisfies this characteristic.

Exact numbers of street children are difficult to determine but there are sources which provide an approximate number of street children in a city at a given time. In some cases it is over estimated and it includes children living on the streets and working children. Many studies on street children (UNICEF Inter-NGO 1983; Anneci 1992 et al.) set the proportion between children "on" the streets and children

"of" the streets to 25 per cent constituted by children living permanently on the streets, and 75 per cent constituted by working children. This general rule can be used in determining an approximate number of children living permanently on the streets who would need sleeping facilities during the period which they would be under medical care.

The number of beds  $B$  required for the health centres for street children in a city are determined by the following formula, adapted from Allen (1976):

$$[1] \quad B = P \cdot t$$

Where

$P$  = Number of patients admitted per day  
 $t$  = Average length of stay (in days)

The number of health centres  $C$  required is obtained through dividing the total number of beds  $B$  by the number of beds per centre  $B_1$  (with the Number of beds per centre equal or less than 15 beds);

$$[2] \quad C = \frac{B}{B_1}$$

And the area of the sleeping area  $S$  is obtained through multiplying the number of beds per centre  $B$ , by the area per bed  $S_1$ :

$$[3] \quad S = B_1 \cdot S_1$$

A study conducted by Doctor Leitão (1995) found that most community health centres in Luanda assisted between 20 to 50 children per day. If all children assisted at those centres were living on the streets and considering an average length of stay of one week, the sleeping area for such demand would require the following number of beds:

$$P = \frac{20 + 50}{2}$$
$$= 35 \text{ Children per day}$$

$$t = 7 \text{ days}$$

The replacement of the above values with  $P$  and  $t$  in formula [1] gives the following total number of beds:

$$[1] \quad B = P \cdot t$$
$$= 35 \times 7$$
$$= 245 \text{ beds}$$

In order to get an accurate figure of the number of primary health care centres for street children required it would be necessary to determine how many of the children assisted at the community health centres considered in the example above were living on the streets, and what was the average length of convalescence of those children. These figures were not available when the field work was conducted in Angola. In such cases, a series of interviews with a significant sample of users is required. The survey should be carried out with the objective of determining an average period of convalescence and a percentage of sick children during a certain period of time. The percentage of sick children gives an index of sick children per day  $I_p$  which is obtained by the following formula:

$$[4] \quad I_p = \frac{P_1}{P_2}$$

Where

$P_1$  = Number of sick children during the period considered

$P_2$  = Number of children of the sample considered

Assuming that all days of the period considered have equal percentages of sick children, then the expected number of patients admitted per day  $P$  would be:

$$[5] \quad P = \frac{I_p \cdot P_t}{t_n}$$

Where

$P_t$  = Estimated number of street children

$t_n$  = Number of days of the period considered

And the average period of convalescence  $t_c$  reported by the children interviewed corresponds to the average period  $t$  during which patients would remain at the health centre:

$$[6] \quad t = t_c$$

From formulae [4], [5] and [6], formula [1] becomes:

$$[7] \quad B = \frac{P_1 \cdot P_t \cdot t_1}{P_2 \cdot t_2}$$

Where

$B$  = Number of beds

$P_1$  = Number of sick children during the period considered

$P_t$  = Estimated Number of street children

$t_1$  = Average period of convalescence

$P_2$  = Number of children of the sample considered

$t_2$  = Number of days of the period considered

Applying these formulae using data from section 4.2.8 (the result of interviews with street children) the number of health centres for street children required in Luanda would be determined as follows:

Approximate number of street children  
both categories of street children = 4000 children  
children "on" the streets = 1300 children

Average length of stay = 4.76  $\approx$  5 days (Average period of convalescence)

Period considered = January - June 1995 (181 days)

Number of children who had been  
sick during this period = 132 children

Sample considered = 172 children

Number of beds per centre = 15 beds

$$\begin{aligned} [4] \quad I_p &= \frac{P_1}{P_2} \\ &= \frac{132}{172} \\ &= 0.76 \end{aligned}$$

$$\begin{aligned} [5] \quad P &= \frac{I_p \cdot P_t}{t_n} \\ &= \frac{0.76 \times 4000}{181} \\ &= 16.96 \text{ admissions per day} \end{aligned}$$

$$\begin{aligned} [1] \quad B &= P \cdot t \\ &= 16.96 \times 5 \\ &= 84.80 \text{ beds} \end{aligned}$$

The same result can be obtained applying formula [7]

$$\begin{aligned} [7] \quad B &= \frac{P_1 \cdot P_t \cdot t_1}{P_2 \cdot t_2} \\ &= \frac{132 \times 4000 \times 5}{172 \times 181} \\ &= 84.80 \text{ beds (considering both categories of street children)} \\ &\text{And...} \\ &= \frac{132 \times 1300 \times 5}{172 \times 181} \\ &= 27.56 \text{ beds (considering children "on" the streets only)} \end{aligned}$$

The Number of centres required is obtained applying formula [2]:

$$\begin{aligned} [2] \quad C &= \frac{B}{B_1} \\ &= \frac{84.80}{15} \\ &= 5.65 = 6 \text{ centres} \end{aligned}$$

After determining the number of beds and the number of health centres required, each area is designed according to the following dimensions:

Table 7 Planning units of a health centre for street children, their areas and occupancy.

Planning Unit	Quantity	Area	occupancy	Notes
Reception and records	1	10.89 m <sup>2</sup>	1 Receptionist 1 Patient 1 Escort	
Waiting room	1	10.86 m <sup>2</sup>	15 seats maximum	1 to 1.5 m <sup>2</sup> per person
Consultation room	2	17.64 m <sup>2</sup>	1 Professional 1 Patient 1 Escort	Also used for examination, treatment and doctors' clerical work (office).
Staff room	1	10.89 m <sup>2</sup>	1 Doctor	Rest room for overnight doctors
Sleeping area	2	43.56 m <sup>2</sup>	15 beds maximum, 1 doctor or nurse or social worker	Single room 7.93 m <sup>2</sup> Two beds or more 7.5 m <sup>2</sup> per bed.
Kitchen	1	6.38 m <sup>2</sup>	1 Cook	
Laundry	1	5.36 m <sup>2</sup>	1 Launderer	
Store	1	17.64 m <sup>2</sup>	1 Storekeeper or pharmacist	
Combined bath, shower and toilets	1	10.89 m <sup>2</sup>	-	
Public toilets	2	17.64 m <sup>2</sup>	-	One for male, one for female and one for paraplegics.

## 5.4 The prototypical building

### 5.4.1 Design brief

The design of spaces for health care facilities for street children should take into account the concept of economy, flexibility and multi-functionality. Local materials should be given preference. Natural ventilation and daylight should be well explored in order to avoid the need of mechanical ventilation or the need for artificial lighting during the day.

Consultation, examination and treatment activities can be either performed in two combined consultation-examination-treatment rooms, or in one consultation-examination room with one separated treatment room. These spaces should be distributed in a way as to create a single block. Consultation and examination rooms are also destined for clerical activities of doctors and social workers. One of these rooms should be sufficiently spacious to allow at least two beds or couches in order to use this room in cases of patients with diseases which require isolation. The advantage would be that the centre would be able to assist other patients without interruption.

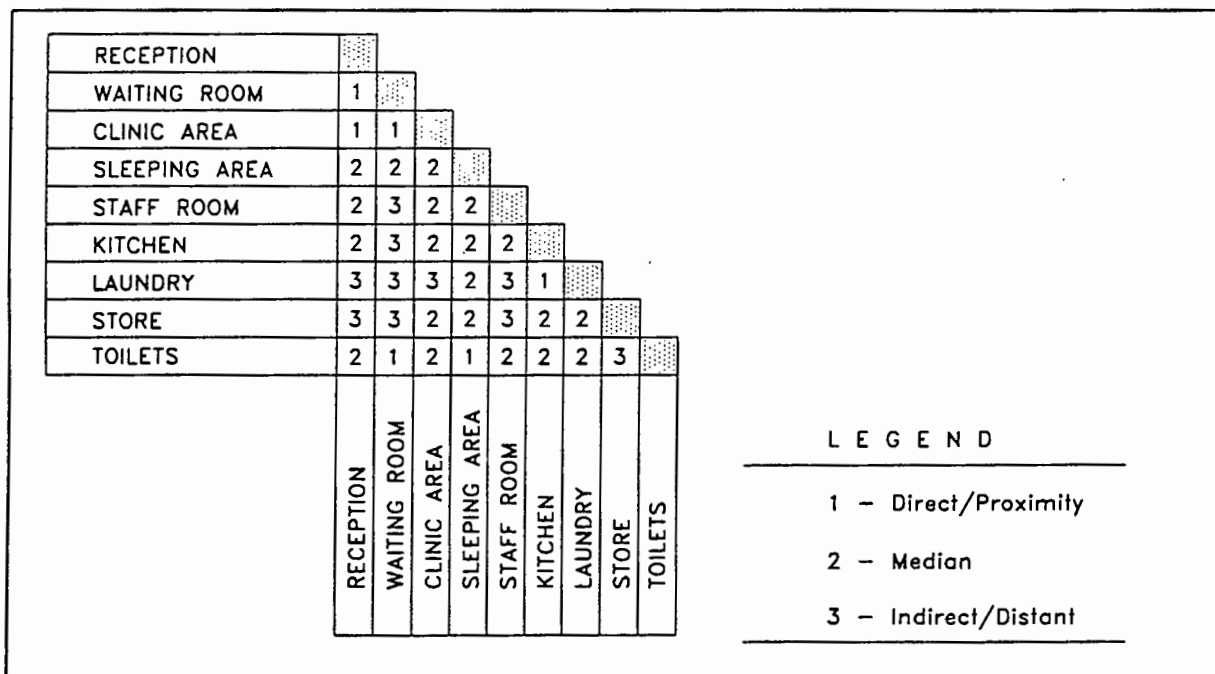

Fig.3 - Relationship matrix

The waiting room must be designed in order to be used for health education which can be attended by all interested children. Its capacity should be at least the same as the capacity of the sleeping area.

The kitchen should have areas for preparation, serving and washing up dishes. Eating facilities should be provided in the sleeping area or children should eat at the bed side. The centre should have a general store for goods of long term use. Goods of immediate use should be kept in cabinets in the respective area where such goods are needed.

A small pharmacy and a laboratory for basic laboratory testing are optional. Medicines could be supplied to patients with prescriptions from the store room, and laboratory testing performed in the examination rooms.

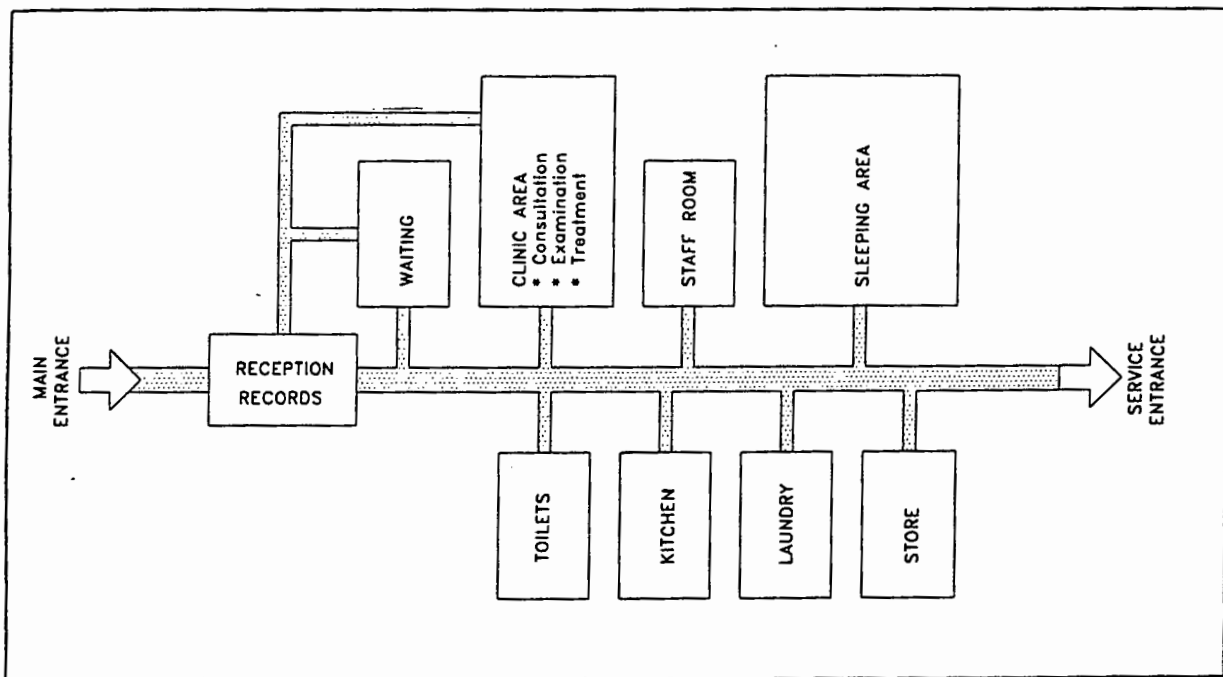

Fig. 4 - Flow chart

## **5.4.2 Schedule of accommodation**

Regardless of its size or level, the basic structure of a health facility is comprised of a reception, waiting, diagnosis, treatment and service spaces. The complexity of these areas vary according to various factors. The most important factors are the size of the facility (health centre, clinic, municipal, provincial or national hospital) and speciality (specialised, general or teaching hospital). In a provincial hospital, for instance, each unit (emergency, out-patients and in-patient departments) has a similar structure of an independent health facility, where each unit interacts and complements the functions of other departments.

Primary health centres for street children are proposed to have the following areas:

- Clinical Area - Reception, waiting, Examination, consultation and treatment;
- Sleeping area - bedrooms
- Services - Kitchen, laundry, store, staff room and toilets.

### **5.4.2.1 Description of activities and rooms**

#### **5.4.2.1.1 Reception**

The reception is a small space where patients have the first contact with the centre for inquiries, appointments and visits. It can also be used for storage of records if a separate records room is not included in the programme. The design of this space should be friendly and attractive to newcomers and it should have wide openings as to reflect both continuity of the external environment and the freedom which street children enjoy on the streets. Receptions in traditional health centres are designed to ensure patients that other members in the centre do not hear the interview between patients and the receptionist, and that patients are not overlooked, in order to make them disclose their problems in case of sensitive ailments (Cammock 1981). In the case of street children this factor is irrelevant. Firstly, street children are used to exposures. Secondly, the disease patterns among them

does not require great discretion, except for older street children who might seek help for gynaecological problems. This factor can be ignored since such cases are occasional. Therefore, sound should be controlled just for audible conversation. Sight obstructors are not required for this space.

Since the reception is a transitional area to the waiting room, it should be located near to the main entrance and in close relationship with the waiting room, clinical area, staff room and toilets. Patients in the waiting room should be able to hear calls and answer them without the need to leave their seats (Cammock 1981). It is also important that patients coming to the health centre should be able to get to other areas without going through the reception if they would not like to be scrutinised by the receptionist. The doctor on duty should be able to access the reception easily during evening services when only two people are working (one doctor and one warden). There should be a communication window between the reception and one of the consultation-treatment rooms which is used in such periods. This window should be kept open during late hours in order to allow the doctor supervise the reception area, and it should be locked during office hours when all personnel are present.

Walls and floor finishes as well as furniture (the counter in particular) should be made of washable material. It is essential to maintain the reception area tidy in order to promote sanitation and hygiene among street children.

The reception should be furnished with a counter, one adjustable stool (chair) and shelves (Cammock 1981). Lockers should be arranged against the wall at the back of the receptionist in cases where the reception area is also used for record storage. The area for reception with records storage lockers is 10.89 square metres. If records are stored in a separate room, the area for reception can be reduced to 6.93 square metres.

Cross ventilation in this space is essential especially for building in cities in the coastal region where minimum and maximum temperatures and levels of relative humidity are on average very high (Luanda, Benguela and Lobito cities). Windows should be equipped with adjustable devices which

guarantee permanent ventilation. The velocity of air flow inside the building should be moderate in order to avoid the blowing about of papers lying on the counter.

Temperature should be maintained at comfort levels as to allow indoor clothes (24 - 25 °C). Room sound proofing should be reduced up to 35 db approximately for audible conversation. Daylight should be acceptable for reading and writing appointments and records. Artificial lighting is necessary for evening services.

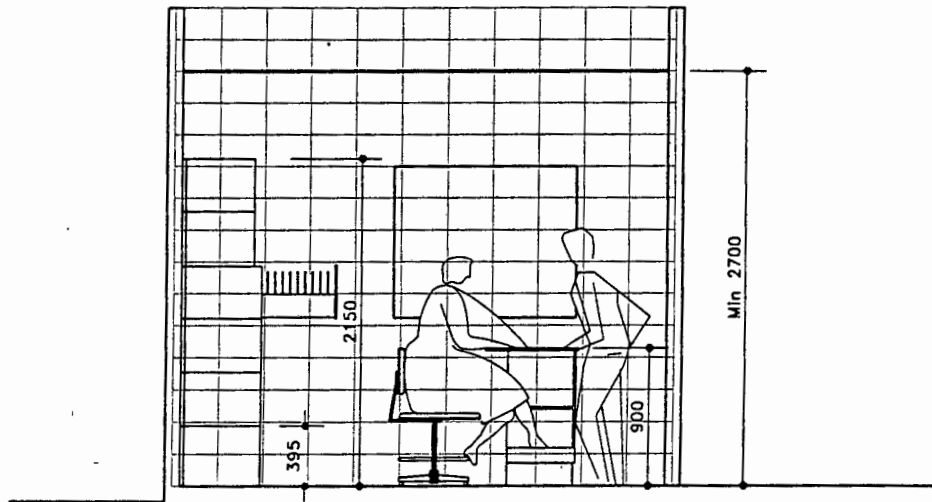

SECTION

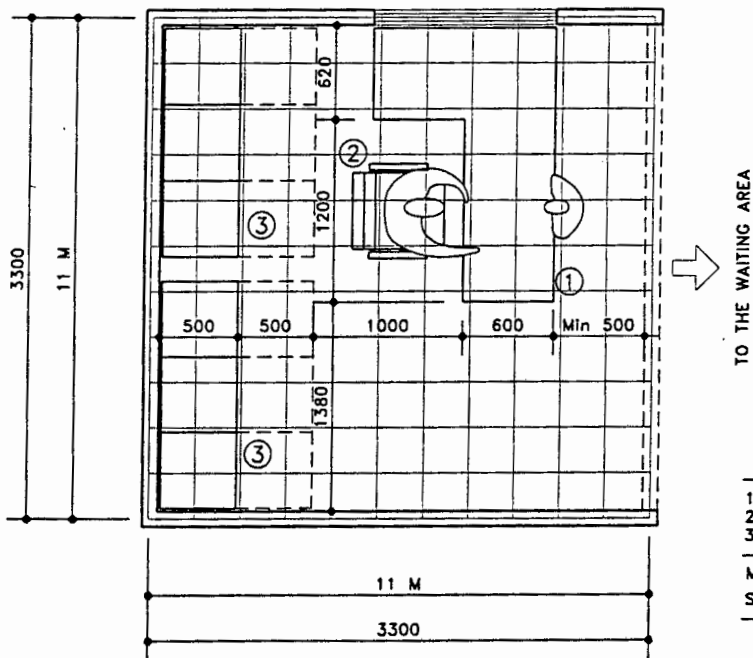

PLAN

Fig. 5 - Reception.

#### 5.4.2.1.2 Waiting area

The waiting area is the space where children wait seated for their appointments with doctors or social workers; where children attend health education classes; and where they stay during the convalescence period or when they come to visit their friends.

This space can be combined with recreation area consisted of a semi-covered area facing the back yard. The open space should be attached to a covered lobby leading to the clinical area and the reception area. This option is advantageous due to the fact that during health education sessions children in the surrounding areas would join the session, including non-street children.

Rustic floor finishes which resembles the surrounding pavements would be acceptable for this space and it should be made of washable materials.

Furniture for this area consists of long benches. Seats should be arranged against walls or in rows with side spaces for circulation.

The net area required for the waiting room is unlimited since the number of participants is variable. However, the number of seats should be limited according to capacity of the centre, site available and financial resources. Area per seat is 1 to 1.5 square metres and the waiting room should not be less than 10.8 square meters.

The waiting room should be well ventilated. Natural ventilation and daylight are the most appropriate for economical reasons and for the open character of this space. Sound exclusion is not critical in this area. It is only necessary for patients to be able to hear calls from the reception and from the consultation room. It should, however, be located at the opposite side of the main entrance where the noise produced by children in the waiting area could be dispersed outside without disturbing other areas. It also provides sight for distraction while children wait for their turn and it helps them dissipate stress. The waiting room should therefore be designed as a multipurpose area which includes waiting, education and recreation activities.

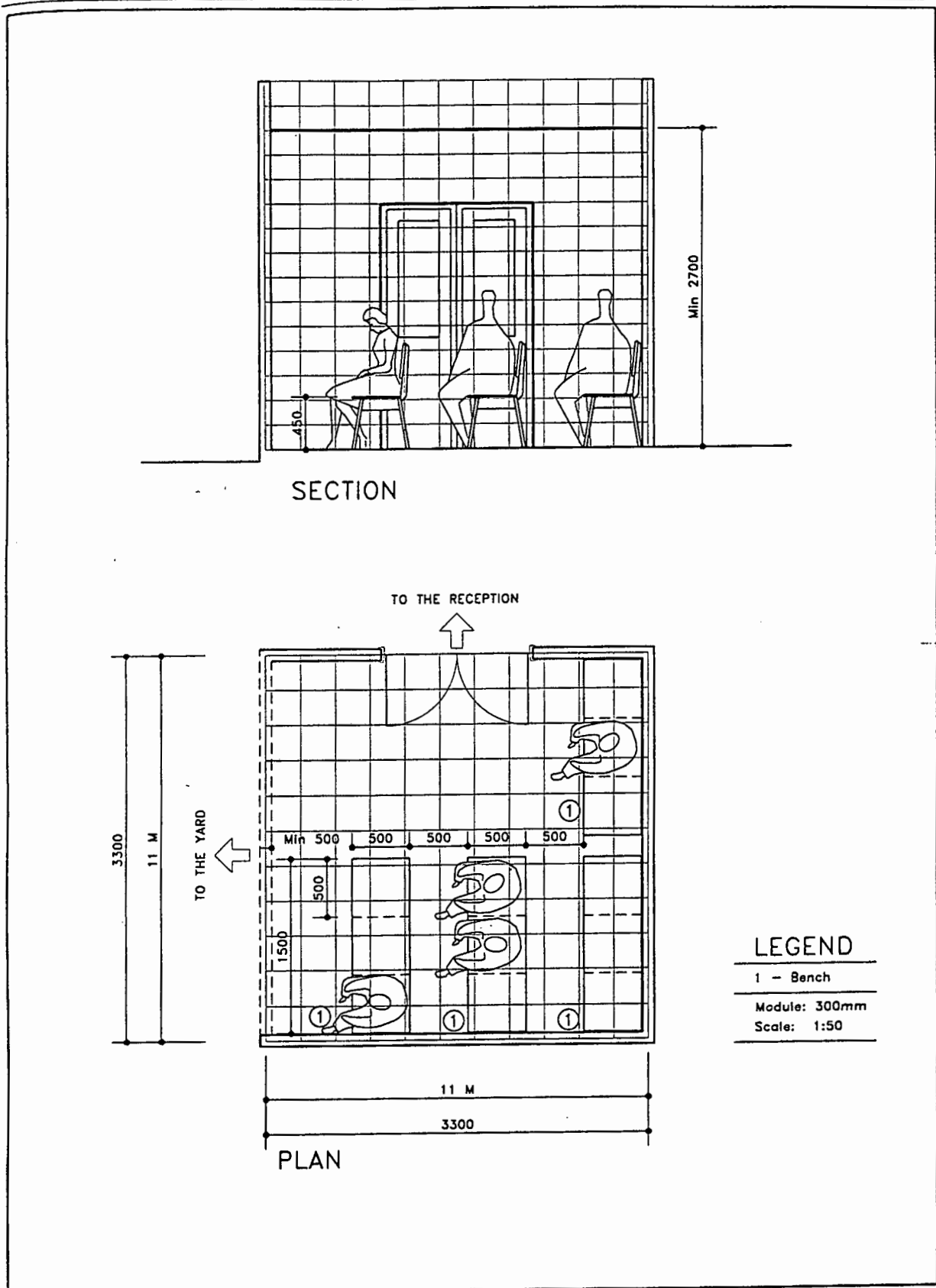

Fig. 6 - Waiting room

#### 5.4.2.1.3 Consultation, examination and treatment rooms

This is the area of the centre where medical activities and doctor's clerical work are performed. Consultation, examination and treatment are similar activities. Rooms for these activities have the same requirements (Cammock 1981). Two rooms designed for this purpose would be sufficient for health centres for street children. It is advisable, however, that a third room be provided, with sufficient space for two beds or two couches which can be used as an isolation room in cases of children with infectious diseases who are waiting transference to specialized hospitals.

Sanitation and hygiene is particularly important in this area. Such as in the reception area, the furniture, walls and floor finishes of the consultation, examination and treatment rooms should also be made of washable material. This room should be provided with hoses linked to the sewage system for connection of sanitary facilities at special beds for patients with cholera.

Furniture for consultation, examination and treatment should be one couch, desk lamp, work top, waste paper bin, disposal bin, hand basin, desk, two to three chairs and cabinets. Other activities performed in these rooms such as basic laboratory testing for malaria, and small surgery for treatment of wounds require special equipment. This equipment should be portable so that it can be stored in cabinets underneath or above worktops (see prototypes included in this chapter).

Minimum area for these rooms is 17.64 m<sup>2</sup>. These rooms should be located in the middle of the building, between the waiting and reception area with easy access to toilets and to the staff room.

Ventilation, temperature and sound reduction should be controled up to the standards specified for the reception area. However, cross ventilation in this area can be undesirable for certain activities (small surgeries for instance), since the surrounding areas can constitute a source of infections.

Daylight is essential for consultations. Artificial lighting is required for examination and treatment activities even in cases where maximum daylight conditions are explored.

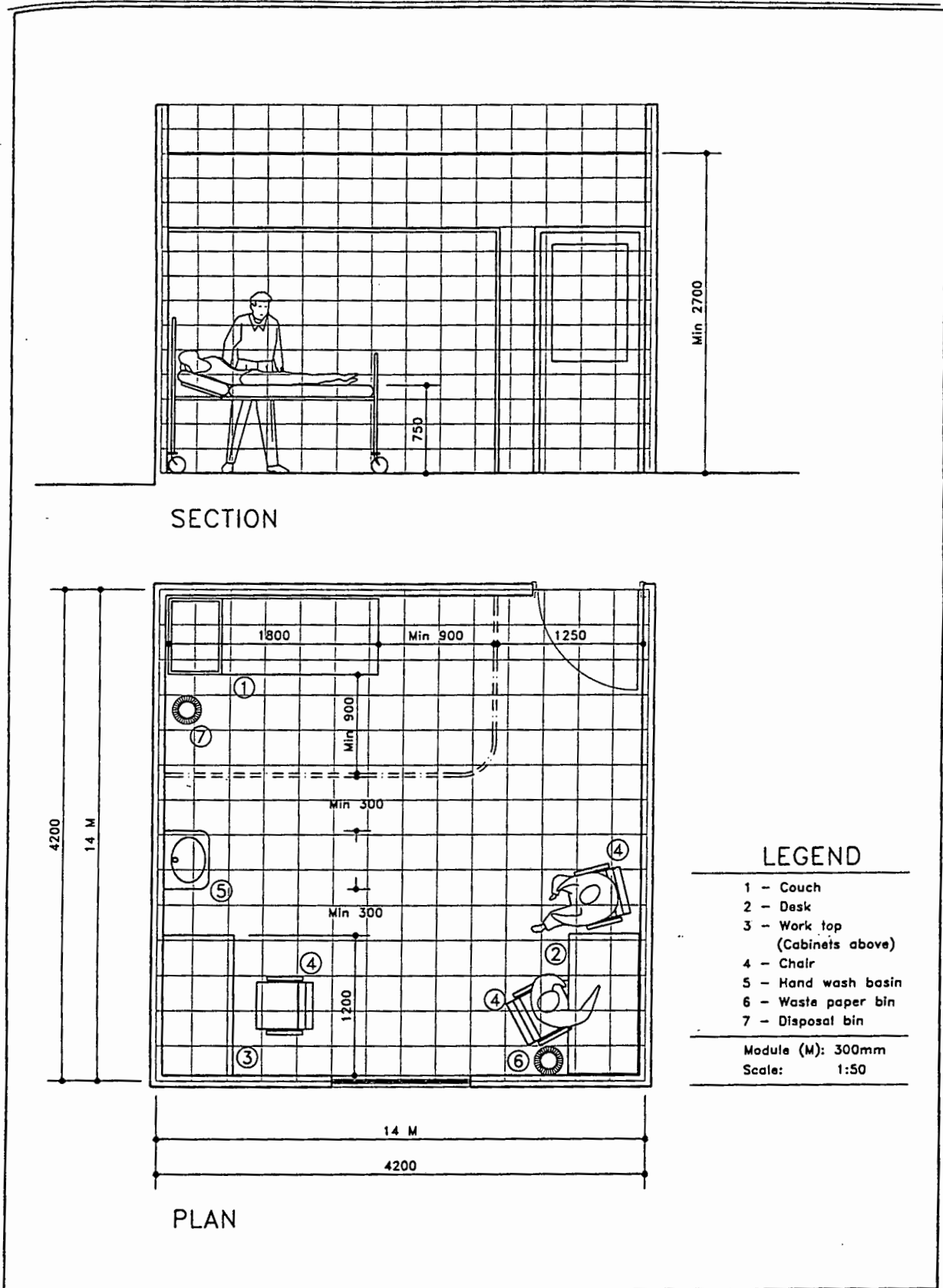

Fig. 7 - Consultation, examination and treatment room.

#### 5.4.2.1.4 Sleeping area

Sleeping conditions have great influence on human well being. They also have influence on a patient's recovery. Temperature and moisture in the sleeping area must be maintained at comfortable levels, and the quality of air must be the least polluted possible for reasonable well being. Some patients, require special conditions for treatment. Burns, for instance, require an environment free of bacteria; the health status of patients with respiratory infections can deteriorate if they are exposed to damp and cold conditions. The sleeping conditions on the streets are hazardous for the health of street children. Risk is increased for these children when they get sick and there are only the traditional health facilities available, where all patients are supposed to have homes. Food, medicines, money and other basic goods are relatively accessible for street children. People in the vicinity rarely offer sleeping places to them unless people have sufficient confidence in some children and use them to guard their assets. Even in such cases they are offered places like parked cars and cubicles for guards which have similar conditions to their traditional sleeping places.

The provision of sleeping areas in the health centres for street children is intended to enable sick children have a proper environment for convalescence without the need of being referred to higher level hospitals. Children should be allowed to stay at the centre up to seven days. On average, minor diseases take two to four days when patients are under proper medical care. Children who require longer periods of treatment should be transferred to higher level hospitals.

The sleeping area should have an independent entrance from the clinical area, and direct access to toilets and to the service area (kitchen and laundry). Separation of the sleeping areas should be compatible with the gravity of the disease. For instance, children with infectious diseases waiting to be transferred to specialized hospitals should be accommodated in separate rooms from other children in order to prevent the spread of such diseases.

The minimum area for sleeping rooms is 7.93 square metres for single rooms and 7.5 square metres per bed for rooms with two or more beds. The maximum capacity per room should be six beds

arranged in two rows of three beds with circulation in the middle. The total number of beds of all sleeping rooms of the centre should not be more than 15 beds.

Each bed should be provided with a cabinet which is used for storage of personal belongings. The sleeping area is also used for meals. Children should eat at bedsides using the top of their cabinets. Eating facilities, if provided, should be arranged at one end of the room consisting of a low table and chairs.

This area should be quiet, well ventilated and it should have good lighting for examination and reading of prescriptions.

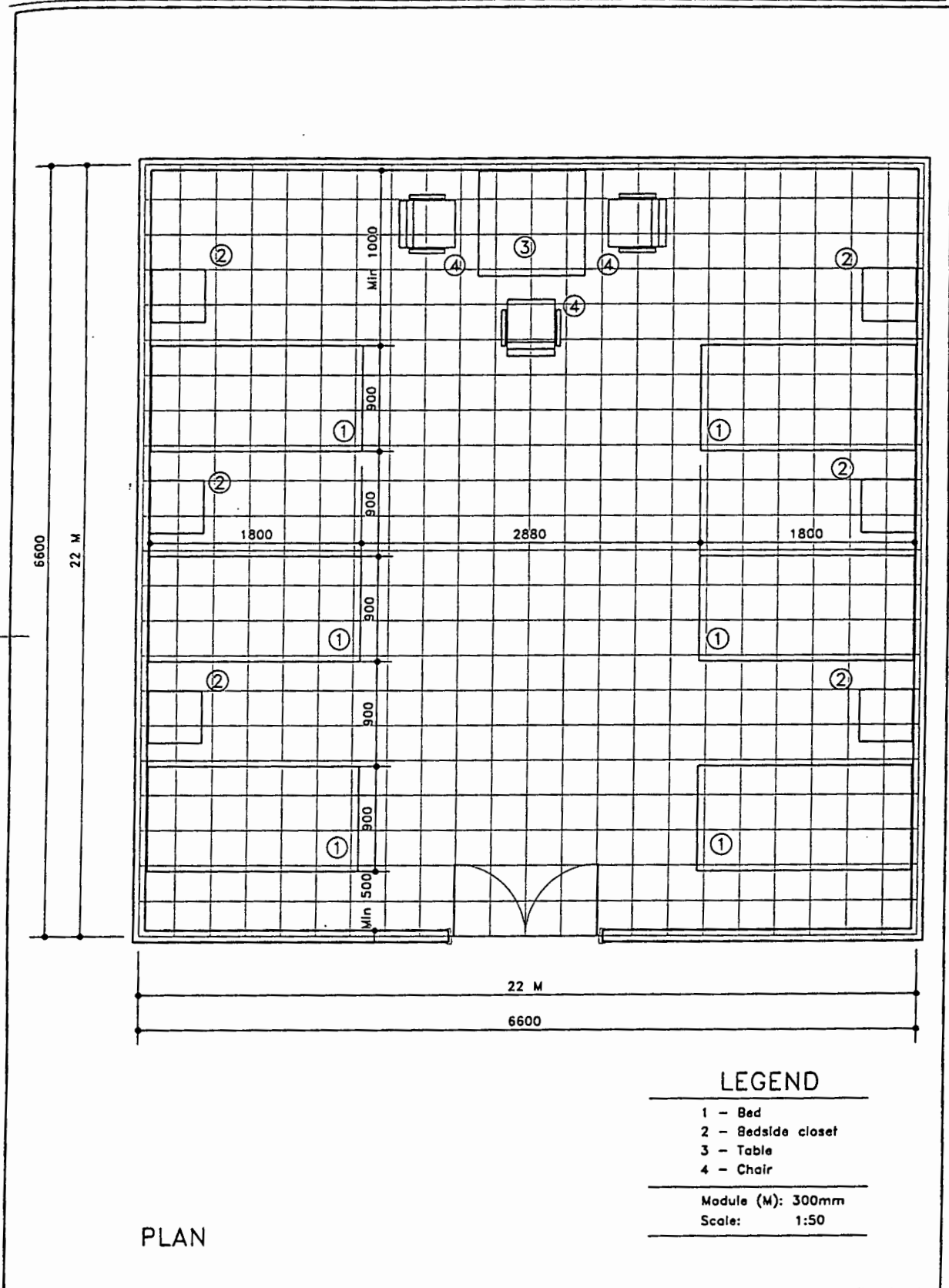

Fig. 8 - Sleeping room.

### 5.4.2.1.5 Staff room

The staff room is a rest space for the doctor in duty. The location and entrance of this room should allow access without contact with unwanted patients. however it should be located in close relationship with the clinical area.

The staff room can also be designed for use by other members of staff for tea. It should be equipped preferably with folding furniture which can be kept against a wall when it is not in use. Furniture for the staff room includes a bed, a table, chairs and wardrobes. The minimum space required for this space is 10.89 square metres. Temperature and lighting in this room should be controlled as to allow domestic activities.

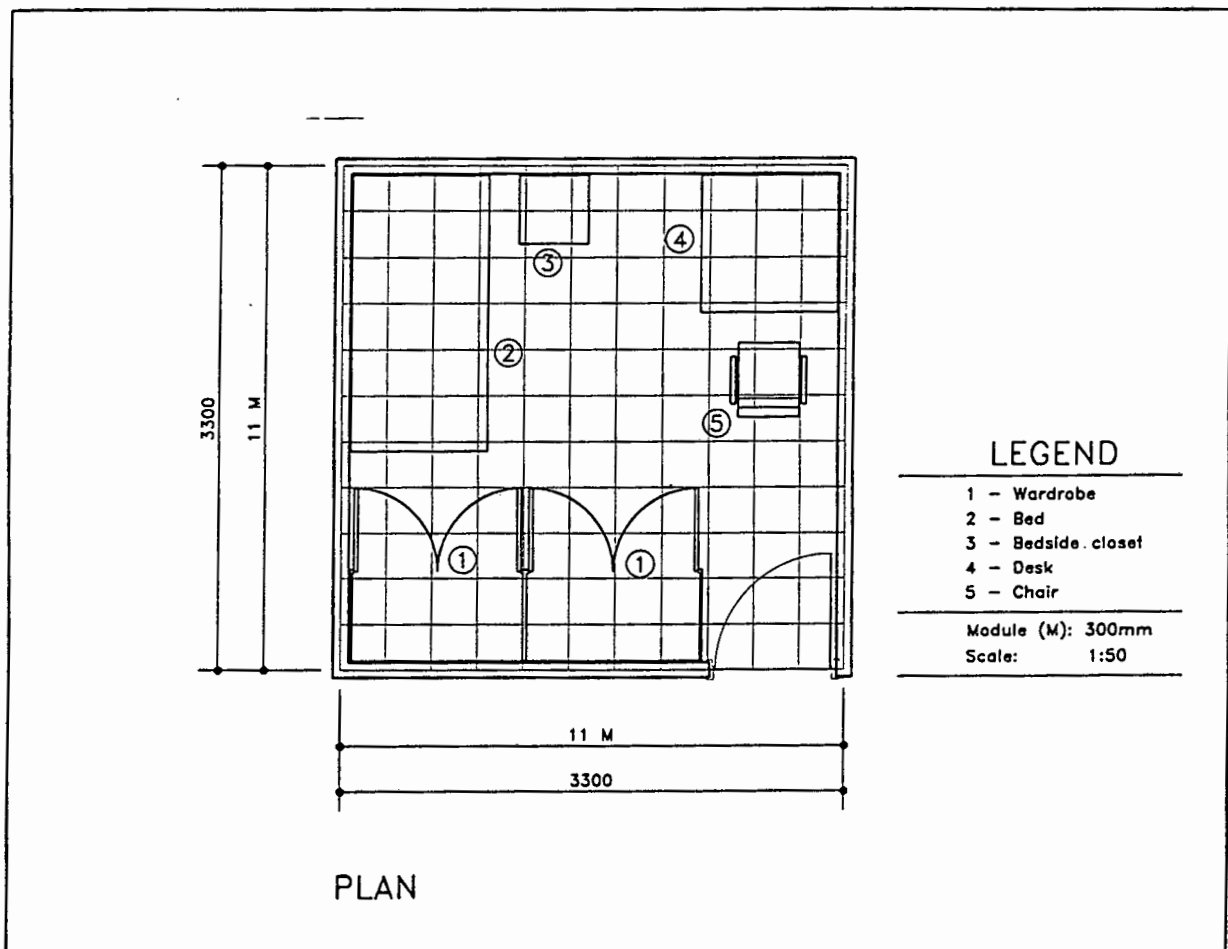

Fig. 9 - Staff room

#### 5.4.2.1.6 Kitchen

Food supply is the second characteristic after sleeping facilities which make these types of primary health centres different from the traditional ones. In Luanda, children who were living on the streets were more likely to have irregular meals. Most of them had between one to two meals per day. In addition to this irregularity was the poor diet. It leads to malnutrition which decreases the body's resistance to diseases. However, it should be clear from the planning stage that food supply and sleeping facilities are only complementary functions of the health centre. It should not be misunderstood and children only in need of food and shelter be admitted. Otherwise, health centres would be full and those in medical care would be forced to go back to the streets after treatment. Food supply and shelter are objectives of feeding and residential institutions such as shelters, orphanages and soup kitchens. Even in cases of children with chronic malnutrition which require medical care, these centres should only give basic assistance and then refer them to higher level hospitals.

The kitchen should be located near to the sleeping area and laundry. It should have independent access for food delivery. Its location close to the laundry and toilets is convenient for plumbing and sewage in order to reduce costs.

The kitchen should be well ventilated and designed with domestic characteristics for preparation, serving and washing up dishes.

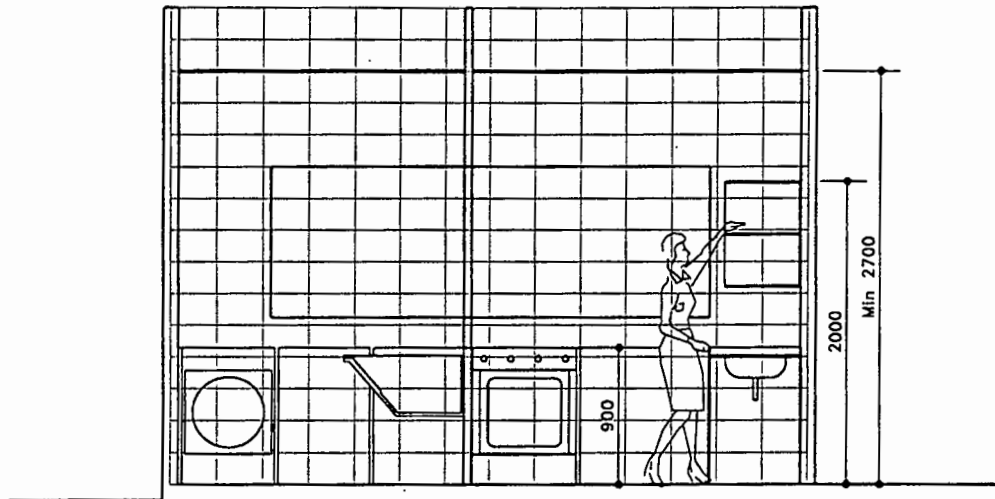

SECTION

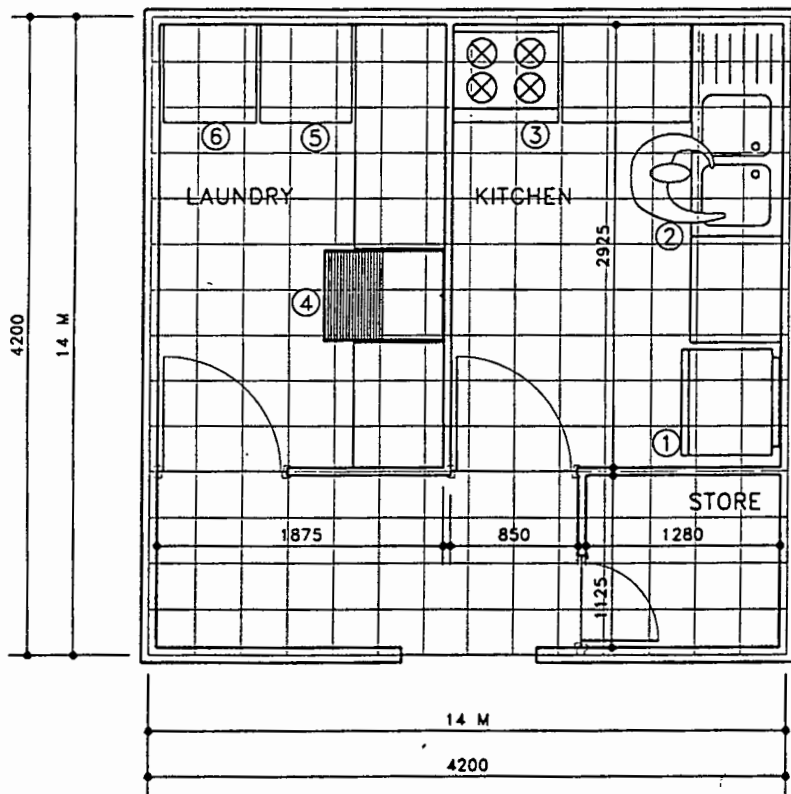

PLAN

LEGEND

- 1 - Fridge
- 2 - Sink
- 3 - Stove
- 4 - Hand washing sink
- 5 - Washing machine
- 6 - Drier

Module (M): 300mm  
Scale: 1:50

Fig. 10 - Kitchen and laundry.

#### **5.4.2.1.7 Laundry**

Water and electricity cuts are frequent in most Angolan cities. This aspect should be considered carefully during the design of laundries. Even if the centres are provided with alternative sources of electricity and water supply, hand washing would possibly be more frequent than the use of automatic systems in such circumstances. Laundries should be provided with hand washing sinks and a drying area outside. It should have the character of a self service facility. In general, street children have nobody to look after them. They are accustomed to look after themselves and, therefore, those with minor health problems would wash their clothes themselves. The staff would only be responsible for laundering of clothes of children in critical condition. When there is water and electricity for operation of the washing machines, dryers and irons, laundering should be done by a staff member in order to avoid hazardous situations and avoid explaining to children how to operate the equipment.

#### **5.4.2.1.8 Store**

The store is a room for storage of food, medicines, clothes, spare beds and cleaning equipment. It is not necessary to create different store rooms for different items. Differentiation can be made through shelves, cabinets and lockers.

The store room serves all areas of the centre. Its location should be easily accessible from any part of the centre but it is not necessary for it to be located in the middle of all areas, since goods in this room are for long term use. All areas should be provided with cabinets in which goods for immediate use are stored. It should have external access to a area accessible by car for loading and unloading of goods.

If the store room is also used for delivery of medicines to patients with prescriptions it should be provided with a chair and a small counter facing to a window. It should be illuminated and ventilated to the level of the reception area.

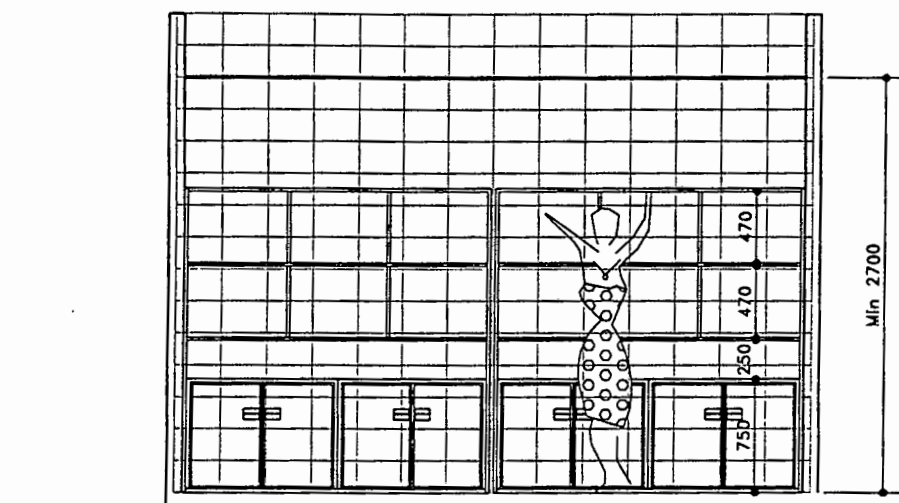

SECTION

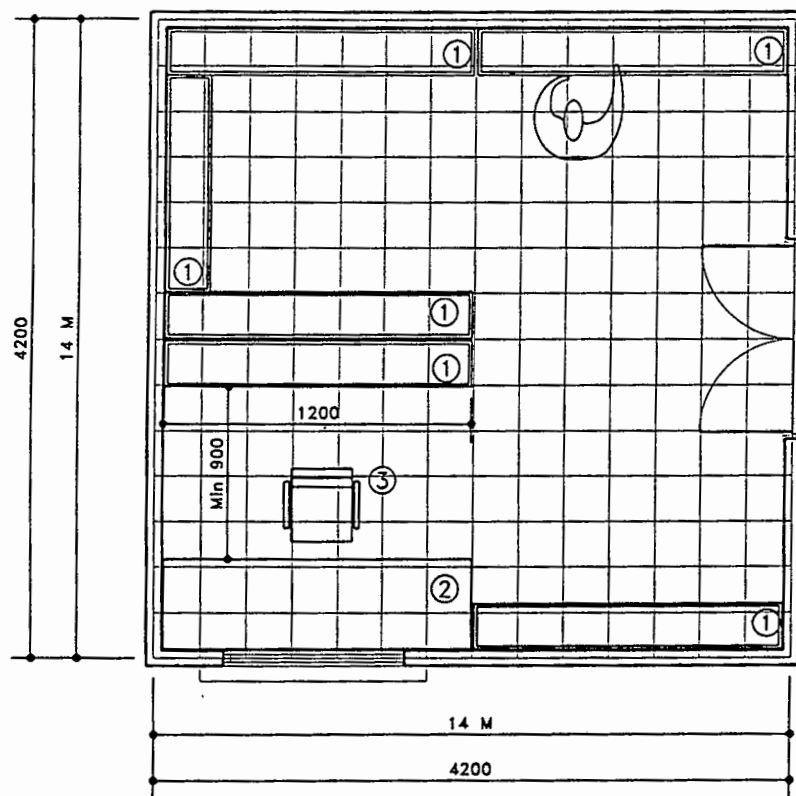

PLAN

LEGEND

- 1 - Shelf
- 2 - Counter
- 3 - Chair

Module (M): 300mm  
Scale: 1:50

Fig. 11 - Store room/pharmacy.

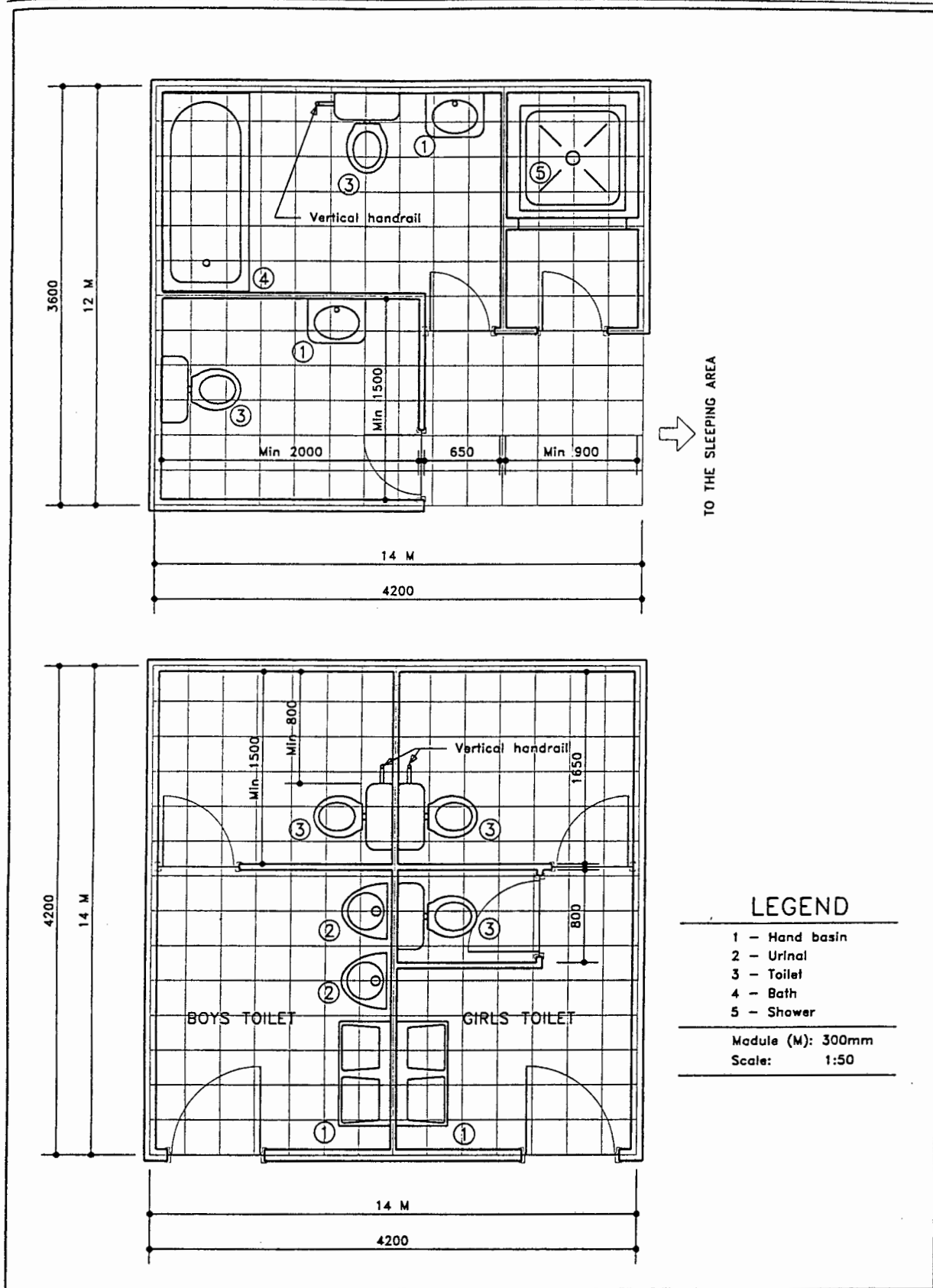

Fig. 12 - Bath and toilet.

### 5.4.3 Construction materials

The selection of material is conditioned to climatic conditions, availability of local material and financial resources.

Climatic conditions influence or, determine in some cases, the selection of type of material to be used. Comfortable internal spaces can be achieved through a combination of materials with high reflection properties and low thermal conductivity (capacity), in hot humid regions where cooling of internal spaces of buildings is required (in costal cities such as Luanda and Lobito); and combination of materials with low insulation and high thermal capacity in order to transmit heat into internal spaces, in cold regions where heating is required. In the hot humid regions of Angola, external walls and roofs should be well insulated. They should be built with materials which prevent excessive heating of internal spaces resulted from direct solar radiation. The ideal solution for external walls and roofs in this region is the creation of two layers separated by a ventilated space between the external and the internal layers. Ventilation between the two layers prevents the transmission of heat from the external layer to the internal one. However, in low cost projects, economy stands before excellence, it is necessary to minimise cost of construction through a compromise of cost, technical requirements and quality. The appropriate solution for external walls in these conditions is the use of 200 mm holed bricks, plastered and painted with light colours. Holed brick walls retain air which has the function of thermal insulation. This characteristic combined with the high reflection property of light colours reduces significantly the impact of sun and prevents excessive heating on internal spaces. This option is economically preferable than the use of double walls with ventilated internal spaces. Double walls consume more material and, are more complicated to build, especially for projects where public participation is required.

An intermediate solution is necessary in the central region of Angola where temperatures vary from moderate in the rainy season to cold in the dry season. Roofs and external walls should be of material

with thermal insulation which prevents excessive heat gain in hot seasons or excessive heat loss in cold seasons. In this region, walls should be made of solid clay bricks damp proofed for protection against occasional heavy rain falls. The concept described above with regard to roofs of buildings in the coastal region is also applicable to the central region, differing only on the slope which should be more than 25 degrees in this last region.

Interior dividing walls should be made of prefabricated timber panels with washable paint finishes, except in damp areas (toilets, kitchen and laundry). These last areas should be made of brick walls covered with glazed tiles up to 1.700 metres high. Prefabricated panels of regular modules are suitable in temporary buildings for reuse in possible alterations. Also, timber panels are easily manufactured locally. The area of wall where hand wash basins are fitted should be covered with impervious material, to at least 1.50 metres high and 45 centimetres wide on both sides.

Material for roofs should be preferably fibrocement sheets laid on steel trusses, and suspended ceilings made of plywood. The space between the roof and ceiling should be ventilated in order to reduce transmission of heat into internal spaces. Ceilings should be painted with washable paint in white or other light colours. In Luanda, prices of fibrocement sheets are usually uniform at all retail stores and at the informal market. At the time of this study, there was only one company which manufactured fibrocement sheets. Some sheets came from other provinces or they were imported. Prices varied according to the proportion of sheets made in Luanda and those made outside, and demands. However, fibrocement sheets were considerably cheaper than tiles which were manufactured by foreign companies.

The roof structure should be preferably of steel trusses, since there were many small companies which manufacture this type of truss. Timber trusses are made by foreign building companies and they are more expensive.

However, some construction materials are not manufactured locally . This situation compels designers to opt for imported materials. Floor finishing materials, and accessories for kitchens and toilets are not manufactured locally. Floor finishes in clinical and sleeping areas require material of good quality in order to maintain acceptable hygiene standards. Floors made of rustic materials or uncovered concrete are not appropriate in these areas. Treatment and sleeping areas should have compact concrete floors covered with impervious washable material of long duration. Careful examination of the local market would give a picture of type of materials and prices which satisfy economic and technical requirements for these type of buildings.

#### **5.4.4 Services**

The principle of cost reduction to which health centres for street children are restricted is applied to the design of the technical installations for this type of building. This section stresses basic aspects to be taken into account for the design of low cost plumbing, electricity, and sewage systems of health centres for street children. It analyses the Angolan context, demands and economical factors at the time of this study. It suggests alternative solutions in order to overcome the inadequacy of the existing systems. However, it does not make an extensive analysis of technical components. Technical handbook or official norms should be consulted in order to obtain detailed technical information.

##### **5.4.4.1 Water supply**

The location of the main system of water supply must be considered during the site selection, in addition to other factors which influence the location of primary health care centres for street children discussed in previous sections. Distances between buildings and the main water supply system influences costs and pressure of water in buildings. The proximity of the building to the main system of water supply reduces the length of pipes to be used which reduces costs. Pressure of water decreases with the increase of the distance between the building and the main duct. The pressure

reduces not only because of physical factors (topography and friction) but also due to the number of buildings connected to the same pipe in that interval which increases in direct proportion with distance. In some cases the pressure becomes too weak which requires creation of tanks for water collection, and afterwards, water is pumped from these tanks to buildings or to elevated tanks from where it is sent by gravity to the buildings.

Storage and treatment of water must be carefully considered during the design of these facilities in any Angolan city. The intermittent character of water distribution in most Angolan cities, where water supply can be interrupted for periods ranging from a few hours to weeks, requires careful attention in order to guarantee acceptable quality and quantity of water necessary to meet the demands of the centre. Inappropriate disposal of sewerage and worn pipes have lead to leakage of infected water into the water system, which constitutes a health threat for users if water is drunk without previous treatment. Therefore, it is necessary to have complementary treatment of water destined for cooking and drinking.

Areas where there is no running water should be avoided. Some areas in Luanda have been without running water for many years and people living in these areas rely on buying water from trucks. These areas would require creation of wells which are not appropriate for health facilities although they would be relatively cheaper than convectional systems, specially in central cities where underground water is abundant and their levels are close to the surface.

The provision of hot water is a secondary requirement which depends on climate conditions and financial resources. It is not critical in costal cities where water temperatures are acceptable throughout the whole year. In central cities the provision of hot water should be provided only in baths and showers. Kitchen sinks, laundries and hand washing basins should be provided with cold water only.

#### **5.4.4.2 Electricity**

Electricity should be calculated for lighting, sockets for low power appliances and sockets for high power appliances. Location of the main system of electricity is essential. Power failures are frequent in all Angolan cities, especially in the rainy season. An alternative source of electricity is necessary in order to prevent interruption of services during power failures. A small motor generator with capacity of supplying energy for lamps and low voltage sockets would be adequate. Appliances of high energy consumption should be used only when the main system is restored.

#### **5.4.4.3 Sewage**

Before a site is selected, it is necessary to carry out a brief study of the surrounding buildings in order to determine the type, state and location of sewerage disposal systems - to determine if buildings are connected to individual (private) septic tanks or they are connected to a general sewage system, and if there are systems of treatment of refuse or not. This information helps the designer to decide whether the sewerage will be discharged to an existing system or if it would be appropriate the creation of an independent septic tank; and whether sewerage will require partial or full treatment before it is discharged to the main system. The system of sewage disposal to be adopted must be clear from an early stage of the design process.

None of the Angolan cities had a sewerage treatment plant at the time of this study. In Luanda for instance, sewerage was being discharged to the sea without previous treatment. Many areas of cities had their sewerage systems blocked and the restoration of such systems could not be achieved in short term period. In cases like this it is viable to use septic tanks. Careful attention must be paid to the location of drinking water storage tanks and septic tanks in order to avoid infections.

#### **5.4.4.4 Ventilation system**

The use of complicated mechanical equipment should be avoided. Such equipment does not only increase the cost of construction but also requires regular supply of energy and maintenance which are scarce and irregular in Angola. The use of air conditioning appliances must be avoided. Even in rooms where natural ventilation is deficient, preference should be given to ceiling or portable fans. Medicines which require storage at constant levels of temperature should be kept in portable refrigerators in order to avoid having to have air conditioning in entire rooms where these medicines are stored.

#### **5.5 Project implementation**

The construction and operation of the health care for street children is proposed to be done by local NGO's. These NGO's should be legally recognized and licensed by the local government. The creation of a non profit organization in Angola has political implications and it involves legal procedures which are time consuming. Projects of health care for street children should be an extension of the program of interventions of a established Local Non-Governmental Organizations, in order to avoid delays or cancellations for judicial reasons.

The institutions responsible for project implementation should promote campaigns for community mobilization. Massive community involvement should be sought from the planning stage. The community should be informed about the objectives of the project and how the future users and the society in general would benefit from such a project. Local leaders and influential members should be involved in decision making and coordination, or in lobbying to the local authority for approval of applications for sites. Professionals of various specialities and auxiliary workers should be mobilized in order to offer their services free of charge. Other members could participate indirectly by donating construction materials or money. Street children should be stimulated to participate, which would

provide them with temporary remunerated employment.

### **5.5.1 Budgets**

The institutions responsible for the implementation of these projects should promote campaigns of fund raising. International NGO's provided funds for projects destined to help street children in Angola. These funds were allocated to local NGO's or governmental institutions provided that the projects were feasible and that the objectives of the project were within the scope of interventions to which such funds were intended. Institutions responsible for implementation of primary health centres for street children projects should have a general knowledge of potential funding institutions and their areas of interventions, before approaching them. However, funds should not only be expected from these institutions. Fund raising is not only necessary for money which covers the cost of construction (including the cost of project). It is also necessary to secure a permanent source of income for staff salaries, drugs and obtaining other supplies, food, water and electricity bills, and maintenance. When the instability in the country is over and emergency programmes are no longer justified, international financial aid to Angola may stop. In such a situation, the institution should be able to identify other sources for complementary funds - government grants, community gifts, private companies, religious groups, government funds, sponsorship, auctions, farms or small stores for sale of donated goods which can not be applied directly to the project.

The process of fund raising requires planning and it involves costs (Cuthbert 1992). The team responsible for fund raising should seek sponsorship from a radio station, television or other mass media which would make advertisements free of charge.

### 5.5.2 Cost control assessment

Access to health care is also conditioned to the financial capacity of the user. Health care must be affordable financially in order to make health services accessible for all and promote equity among the members to which it has been proposed to serve (Joseph 1984). Hence, users must pay for costs of travelling, consultation, examination and treatment, except in systems where health care is subsidized. Street children have petty income which barely covers their expenses on food. The proposed primary health care centres for street children should have the character of non-profit institutions, which means that they do not generate direct revenue from services offered.

The objective of cost effectiveness assessment is to determine whether or not it is worthwhile to implement a project. One technique of assessing cost effectiveness is from the balance between the estimated cost of a project and its expected profit (Miller 1988; Reuthinger 1970, et al). The other procedure is to assess the balance between financial resources available for a project and its estimated cost. Both methods require approximate knowledge of costs of the project for which the feasibility study is intended. Building project appraisals are based on costs of similar projects implemented previously. Past projects give an average cost per square metre which can be used to calculate the approximate cost of a new project.

There were no databases of costs for buildings of the type proposed when this study was conducted. Estimates of costs were only possible using as a base the costs of the existing communal health centres and shelters for street children. From communal health centres it would be possible to estimate costs of the medical component of the centre (staff, medicine, medical equipment, water and electricity), and from shelters it would be possible to evaluate approximately the cost of the sleeping area of the health centre (food and beds). However there were no records of such information at the institutions surveyed in Angola. Representatives of the institutions contacted were neither able to give detailed information about costs of construction nor costs of operation of their institutions. The reasons

were, among others, the fact that most shelters were operating in old buildings adapted to shelters which had no records of the construction costs available. Hospitals with in-patient facilities could give an idea of the costs per bed. However costs of operation for a big hospital would be more expensive than it should be for low cost health centres for street children. On the other hand records with such information were also not available at such institutions.

There are no concrete funds for these kind of projects. If the project is found to be necessary, the institution responsible for the implementation of such project has to raise whatever amount of money the project requires. It means that funds required are determined by the magnitude of the project. It is not possible to assess the feasibility for these kind of projects through the balance between financial resources available and the estimated cost, since one of the variables is not known.

It is also not reliable to use predefined values which the building companies in Angola use for costing their work. The use of such values could lead either to underestimates or overestimates of the cost of a project. The reason is that primary health centre for street children constitute a new category which has not been considered when the range of such prices was established.

The cost control in these circumstances can be assessed accurately only by estimating costs using prototypes designed taking into account minimum spaces requirement for each planning unit, appropriate layout and equipment required. Each planning unit is measured separately in order to determine quantities of material required for building each component, cost of labour, cost of project, equipment, percentages for taxes, damages and other indirect costs involved. These costs vary according to many factors. The most important factors are:

- Time of construction;
- Context of the place where the centre is intended to be built;

- Type of preliminary works required;
- Cost of land;
- Cost of labour;
- Type of Builder;
- Availability of local materials;
- Nature of manpower;
- Regimen and applicability of taxes;
- Use or not of public participation.

The sum of costs of all units gives approximate cost of the project which is the amount of money which the team responsible for implementation of the project would have to raise. Several projects implemented using this process would help creating a database which can be used for future projects.

## 5.6 Case study

The purpose of this design was to provide a typical layout of a proposed health centre for street children. The design was also intended to serve as a draft, which the entity interested in implementing this project could use as a basis for elaborating working drawings.

### 5.6.1 Location

The site considered was situated at the junction of the Quimabanda and Paiva de Andrade streets at Lumeji square in Luanda (see fig. 13). It was located in the city centre at a distance of approximately 600 metres from the main areas where street children slept (Mutamba and Amilcar Cabral Squares, Lello, BPA and Escola Portuguesa). The surrounding areas consisted mainly of office buildings, and the site was close to the main streets which lead to areas where shelters for street children were located. The site was at the edge of a parking zone where people undertaking driving tests parked their cars. There was a former kiosk which sold bread from subsidised governmental bakeries on one end of the site. It is proposed to demolish in this design. The area was also used as a taxi terminus and by street vendors who sold small goods to people waiting for taxis or buses. These characteristics attracted street children.

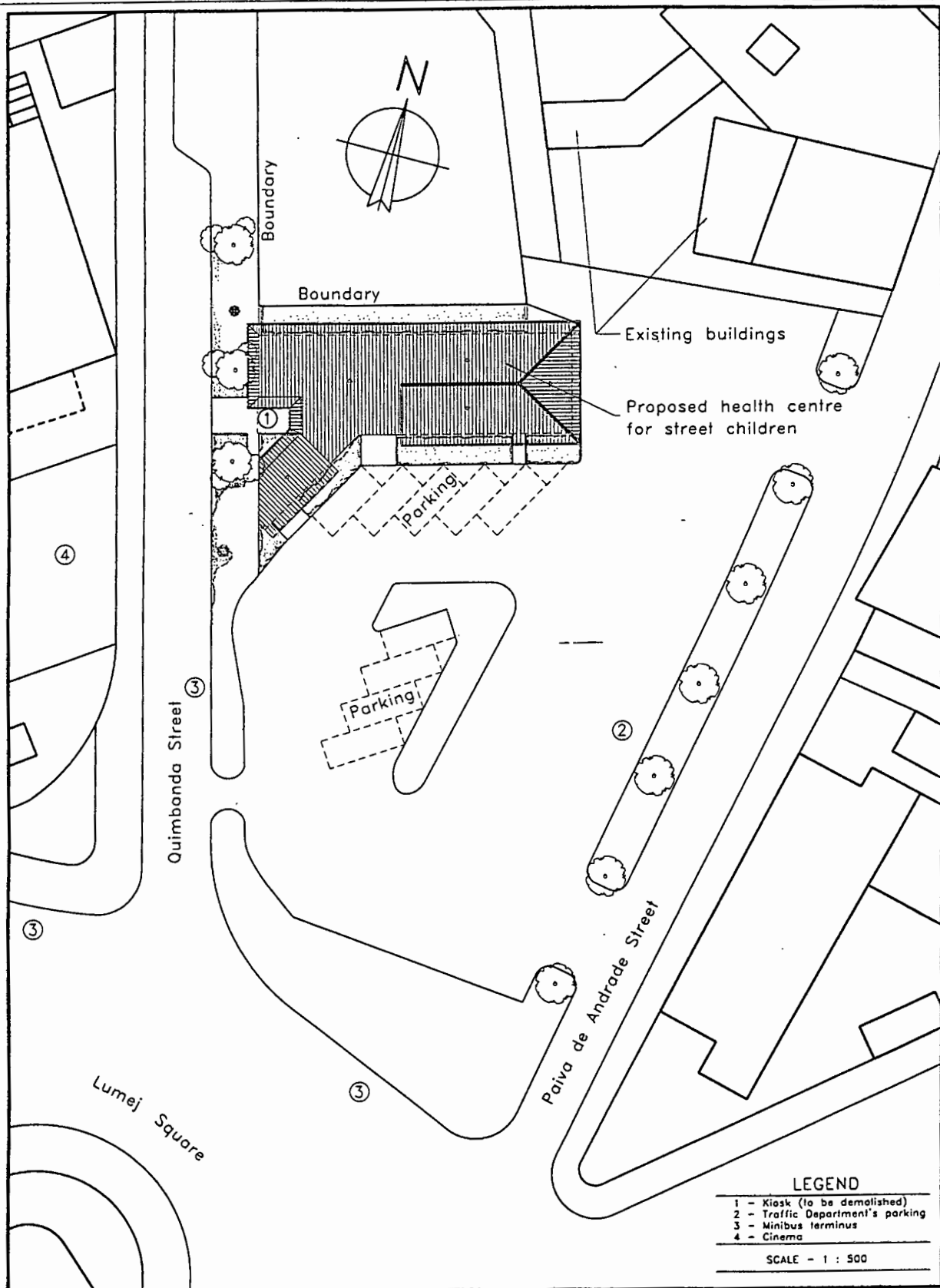

Fig. 13 - Case study: site plan.

### 5.6.2 Design concepts

The limited space available conditioned the layout and dimensioning of the spaces. The dispositions in the guidelines discussed in the previous chapter were therefore slightly changed in order to adapt them to the characteristics of the site and to the actual context.

The orientation of the building was consistent with the boundaries. The long façades have been orientated to North West and South East.

The centre has been subdivided into three blocks:

- Medical block - containing a reception, waiting room, a combined consultation-examination room, one treatment room, a staff room and toilets;
- Sleeping block - containing two sleeping rooms with three beds each and a bath, and;
- Service block - containing a kitchen, laundry and store.

The total floor area of the centre was 241.14 square metres of which 48.5 per cent was occupied by the medical area, 34.2 per cent by the sleeping area and 17.3 by the service area.

The centre would admit up to 14 children per week at a rate of two admissions per day and for an average period of three days.

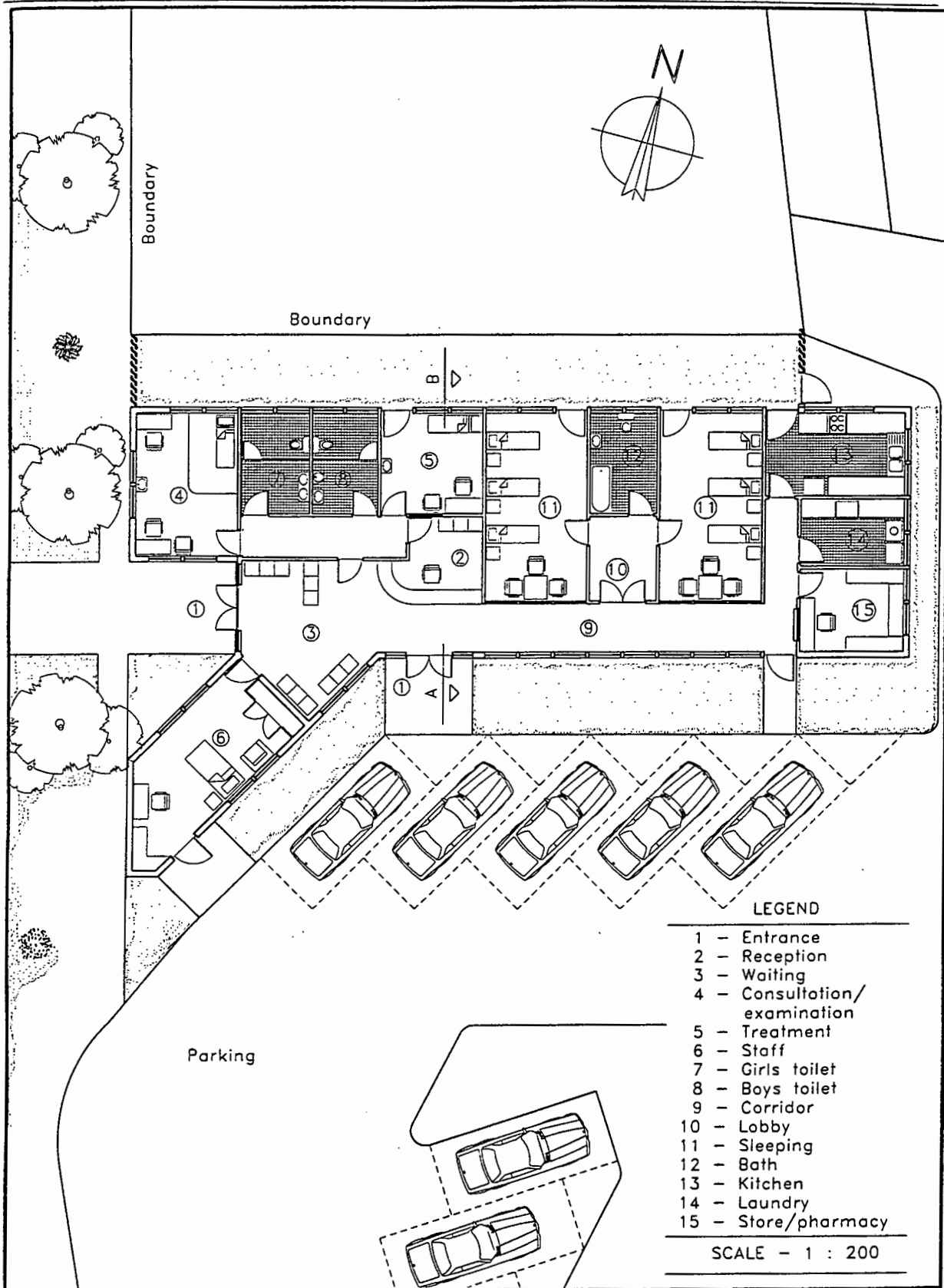

Fig. 14 - Case study: floor plan (see appendix A for details).

### **5.6.3 Technical specifications**

#### **5.6.3.1 Structure**

The structure of the building has been proposed to be 700X250 millimetres concrete footing at 500 millimetres below the earth line for external and structural walls. However these dimensions should be subject to adjustment by a structural engineer during the working drawings stage. The roof structure would be steel trusses made to order according to the different lengths of spans, as shown in the roof plan.

#### **5.6.3.2 Walls**

External walls have been proposed to be made of 300X200X200 millimetres holed bricks and internal dividing walls of 300X200X90 millimetres holed bricks, except in the sleeping area. The walls of this area would be of prefabricated panels which could be removed to extend the sleeping area. The extended sleeping area would incorporate the treatment room and the reception. In such cases, the reception would also function in the waiting area and the treatment room could function in the staff room.

#### **5.6.3.3 Roofs**

Roofs would be ridge roofs of fibrocement sheets painted in red which would match the roof style of the surrounding buildings. However, if during the implementation stage the funds raised are sufficient, this material could be replaced with tiles. Ceilings would be in 3 millimetres thick plywood panels painted in light colours.

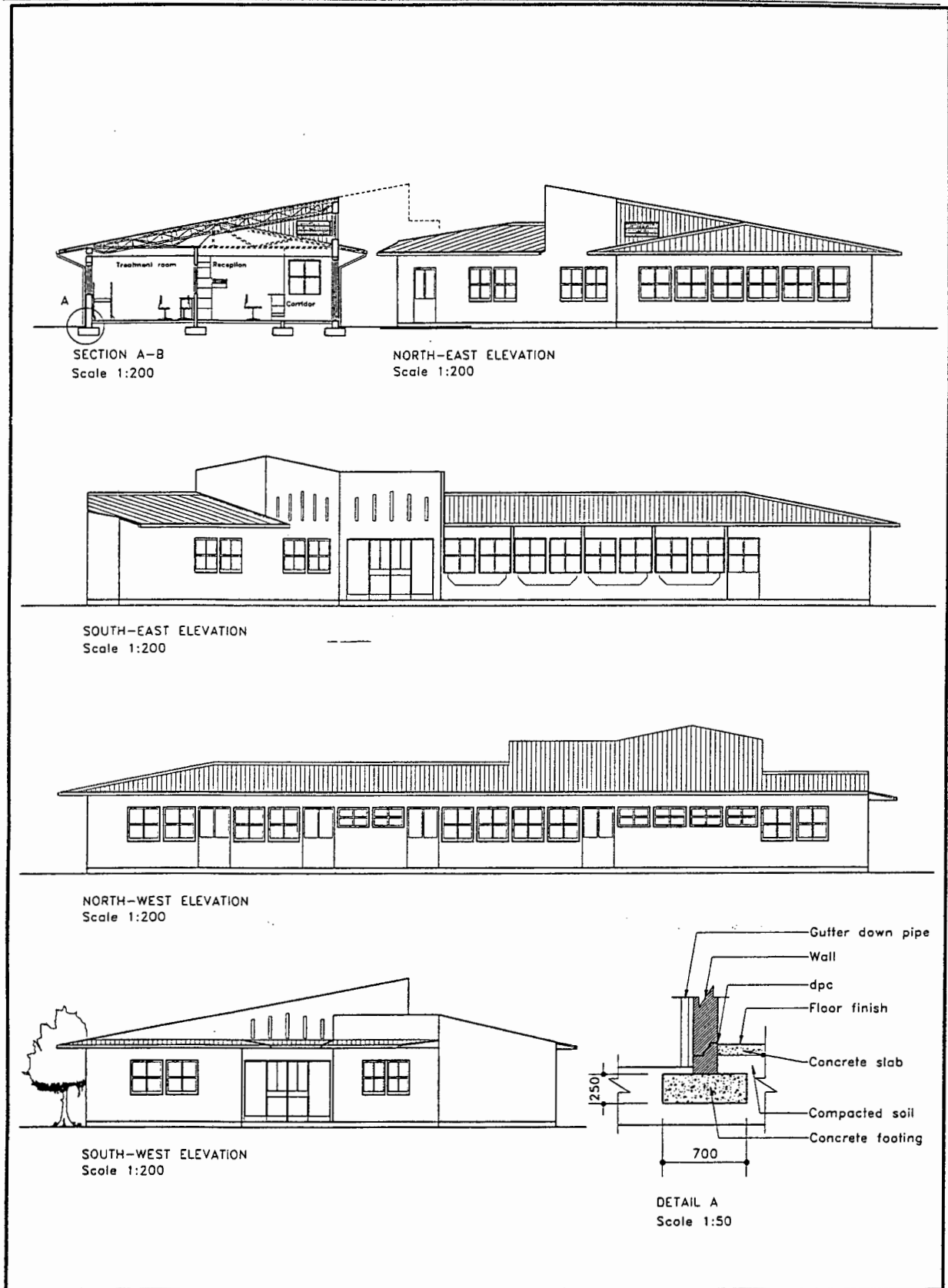

Fig. 15 - Case study: cross section and elevations (see appendix A for details).

#### **5.6.3.4 Openings**

All window openings were 1.100 metres wide. They differed in height and were thus one of two dimensions: 1.10X1.20 and 1.2X0.70 metres. Frames for both windows and doors are proposed to be in wood with glass openings or timber lovres. Openings above the two main doors should be protected with wire mesh in order to prevent mosquitoes and flies entering the building. The openings in the South-East and in the South-West sides should be protected with horizontal shading devices or overhang roofs for protection against the late morning and early afternoon sun.

#### **5.6.3.5 Technical installations**

Water, electricity and sewerage systems would be connected to the existing systems. However it should be provided with alternative systems for electricity and water supply. Floor, wall and ceiling finishes as well as external areas should be according to the directions given in the guidelines presented earlier.

## CHAPTER 6

### CONCLUSIONS

Street children constitute a micro-society based on special rules. They are indeed a very difficult group of individuals to deal with. All effort should be made to prevent children from choosing life on the streets as a preferred option.

The extinction of the street children phenomenon is only possible if the causes of its existence are eliminated. One of the main causes of street children is poverty, which can be attenuated but never eliminated. Ill-health in developing countries and all problems related to poverty will always be present, and therefore it is necessary to find alternatives to deal with these problems. The primary challenge in these countries is how to provide facilities in sufficient numbers to satisfy the needs of so many people.

It was evident that health care facilities for street children were needed. The experiences of the clinics for street youth in USA, the health centre in Australia and the primary health care programme for street children in Honduras, could serve as precedent for development of health care facilities and be adapted to different contexts. According to professionals working with street children, one feature that was required for shelters was to be of reduced capacity as a way of creating an environment equivalent to that observed in ordinary homes. From interviews with social workers it was found that in most cases shelters had accommodated more children than the real capacity of the building. Such an environment is not suitable for health care services.

The main cause of street children in Angola has been the war. It can be inferred from the high number of street children born in other provinces, which were observed in the sample considered. However, there were also children born in Luanda living on the streets. It meant that there were other social and economic reasons which made these children abandon their homes. The questionnaires used during

the interviews were not designed to investigate in depth the causes of the existence of street children, because the field work was focused only on factors that had direct influences on health and health care of the street children.

Returning to the core questions which this study addresses, the first question is on how existing health facilities in Angola have failed in providing for the health needs of street children. The failure of the traditional health facilities in this regard has been reflected by the street children's access to health care facilities in Luanda which is low, especially for those living on the streets. Children living in shelters had been assisted at the shelter's health centre, or they had been referred to provincial hospitals and followed up by the shelter's staff. Those living on the streets had two obstacles: first they needed referrals from a trusted entity, or they had to be accompanied by an adult, in order to use a provincial hospital. Second, community health centres were overcrowded and patients had to pay for medicines. These were the reasons why, among children interviewed on the streets, they had been treated mostly at provincial hospitals. They had been taken to these hospitals generally when they got to critical condition. In such conditions there were few chances of being refused admission. Otherwise they had to wait for the mobile clinic, to seek help from friends or simply they had not had treatment at all.

The second question is whether or not street children in Angola would use specialized primary health facilities, since street children in general are held to be suspicious of formal institutions. There was much evidence of physical and/or sexual abuse from most of the children living on the streets, which was their reason for becoming suspicious of adults who were largely responsible for it. Social Workers and other professionals experienced in working with street children have developed principles of dealing with them in order to build trust and help them build self-confidence. Many institutions observing those basic principles had made significant progress in helping street children. In some contexts street children were found not to be very suspicious and they were very cooperative in some cases. What children hope to find on the streets is mainly freedom and therefore any facility for them

should be adapted to this lifestyle. They would not tolerate being locked up in places against their will . It would make them feel as if they were in prison instead of in a welfare institution. Therefore, the reason that makes street children avoid institutions like the "*Places of Safety*" or the "*FEBEM*" facilities lies more in the conception of the programme rather than in the street children's behaviour.

In the case of street children in Angola, the following facts were considered:

- The high indices of usage of the existing facilities for street children: the shelters were filled on the date of inauguration, and the mobile van was always crowded.
- Most of the street children interviewed stated that they would prefer to use specialised health centres: a health centre attached to a shelter or a health centre just for street children;
- From observation in the field and from informal interviews, it was revealed that many children pretended to be street children or orphans in order to gain access to street children's facilities: orphanages, shelters, mobile clinic and feeding schemes.

These facts showed that street children in Luanda had no reluctance to entering institutional life, which answers the question whether or not street children in Angola would use specialized health centres. Suspicion existed in the sense of awareness towards strange people due to experiences of assault and on some occasions having been arrested by the police. Therefore, before they got involved with anybody their first preoccupation was to find out what the real objective was.

The third question relates to the viability of creating primary health care facilities in Angola which cater just for street children, considering the economic and medical context of this country. There was a need for improvement of health care delivery to street children. In addition to the common health problems that street children in other cities around the world have (drug and solvent abuse, assaults, malnutrition

and bad sleeping arrangements), street children in Luanda had also had other problems, those which the entire community of the city had been experiencing (as described earlier): bad services at the community health centres and hospitals, poor sanitation and poor quality of drinking water. These have, as a consequence, increased the spread of infectious diseases such as cholera and malaria (which is very common in Luanda especially in the rainy season). It has been reflected in the section on the most frequent type of diseases observed amongst the sample studied.

Without taking into account possible increases, the number of street children in Luanda at the time of this study, would require at least 21 shelters in order to keep all street children off the streets. Each shelter would accommodate approximately 60 street children (the average number of children per shelter in Luanda at the time of interviews). If each shelter was provided with a health centre it would imply 21 health centres. As this survey found, children living on the streets had no access to shelters' health centres, both because of the location of these facilities and because they were full. If children went there they would eventually be assisted and will return to the streets.

From the indices of sickness (0.42 per cent sick children per day according to this study) and considering the range of mean period of cure for the diseases observed in the sample studied (2.7 to 7.5 days), the number of beds required would be between 11.4 to 31.80 beds, which was approximately two thirds of the average capacity of the existing shelters. If each centre had a sleeping area for 10 children, four health centres would be sufficient to assist both children on the streets and those referred from shelters. It would prevent or reduce referrals to provincial hospitals of cases that could be treated at primary health care centres.

The answer to the fourth question on how conventional primary health centres should be adapted to cater better for the needs of street children consists in upgrading the existing community health centres (as suggested during the interviews with professionals working with street children in Angola). The Upgrading process should be towards the provision of temporary sleeping and eating facilities. The

location of these centres should be assessed prior to the upgrading process in order to upgrade only those centres near to places where street children gather. Community health centres located far from places where street children customarily stay, even though it would have the advantage of integrating children into their communities, it would not meet their basic requirements. The upgraded community health centres would have similar concepts and functions as the primary health centres exclusively for street children, differing only on the fact that they would cater for a broader range of users.

The last question is about the integration of primary health care facilities exclusively for street children into the health system in Angola and their relation to other institutions offering services to street children. These centres should be integrated into the lower level of the health care hierarchy. They should serve as a link between higher level hospitals and shelters, drop-in-centres and children living on the streets. There should be cooperation between primary health centres for street children and other institutions offering services to street children through exchange of services, in order to create a multidisciplinary network where every institution complements the activities of others. Networking is required not only between facilities giving services for street children but also between these facilities and others serving the rest of the community.

There is a need to secure the health care of street children through a centre which is designed to take into account all the factors discussed above. It would improve the access and quality of street children to health care. What is necessary to be done, and it is valid to any facility in any context, is to design the facility keeping in mind the result which it is hoped will be achieved, and that the result will be well accepted by the future users. The only way of ensuring the result is to identify the needs and afterwards let the users decide what they want and, where and how they expect to be served. The following step is just a matter of implementing these demands.

APPENDIX A  
DETAILS OF THE CASE STUDY DESIGN —



1 - Location of the existing shelters and the site for the proposed health centre

**APPENDIX B**

**PHOTOGRAPHS OF STREET CHILDREN AND SHELTERS IN LUANDA**



1 - A street vendor boy waiting for his mother on their way to work (left) and a group of street children at Futungo Shelter's playground (right)



2 - A group of street children outside Palanca Shelter

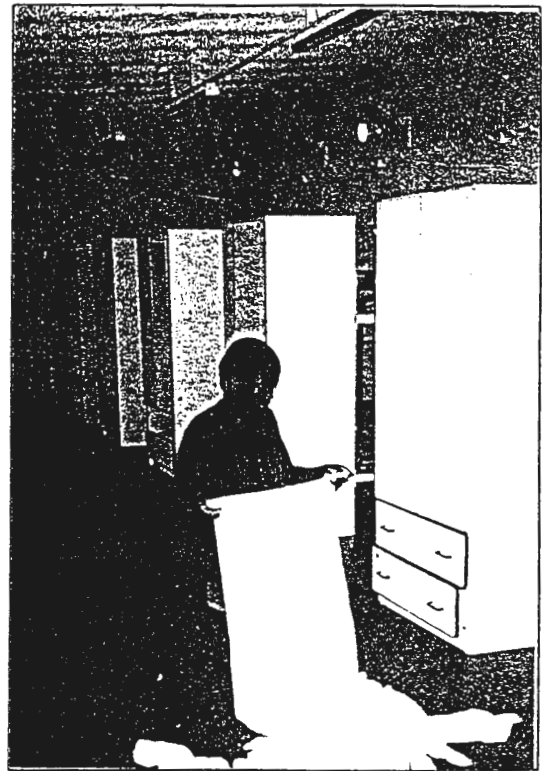
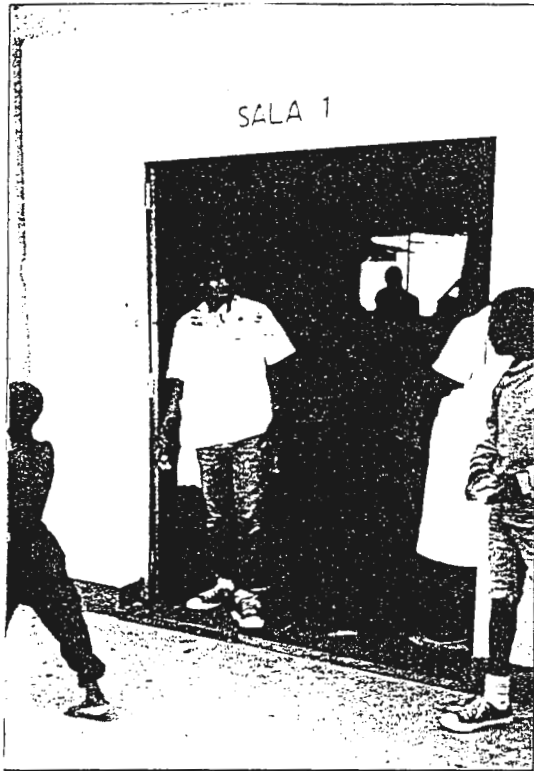

5 - Tecnocarro Shelter: classroom entrance (left) and arrangement of wardrobes in the sleeping rooms (right)

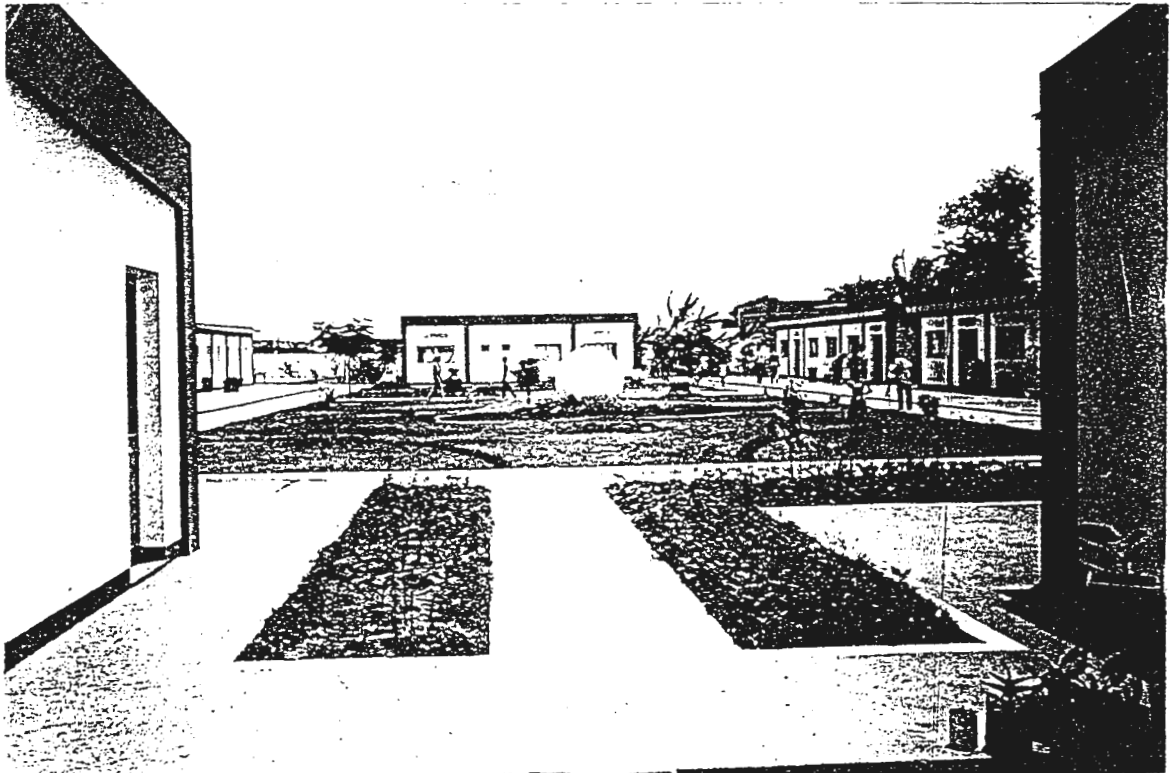

6 - Tecnocarro Shelter:  
view of the internal yard

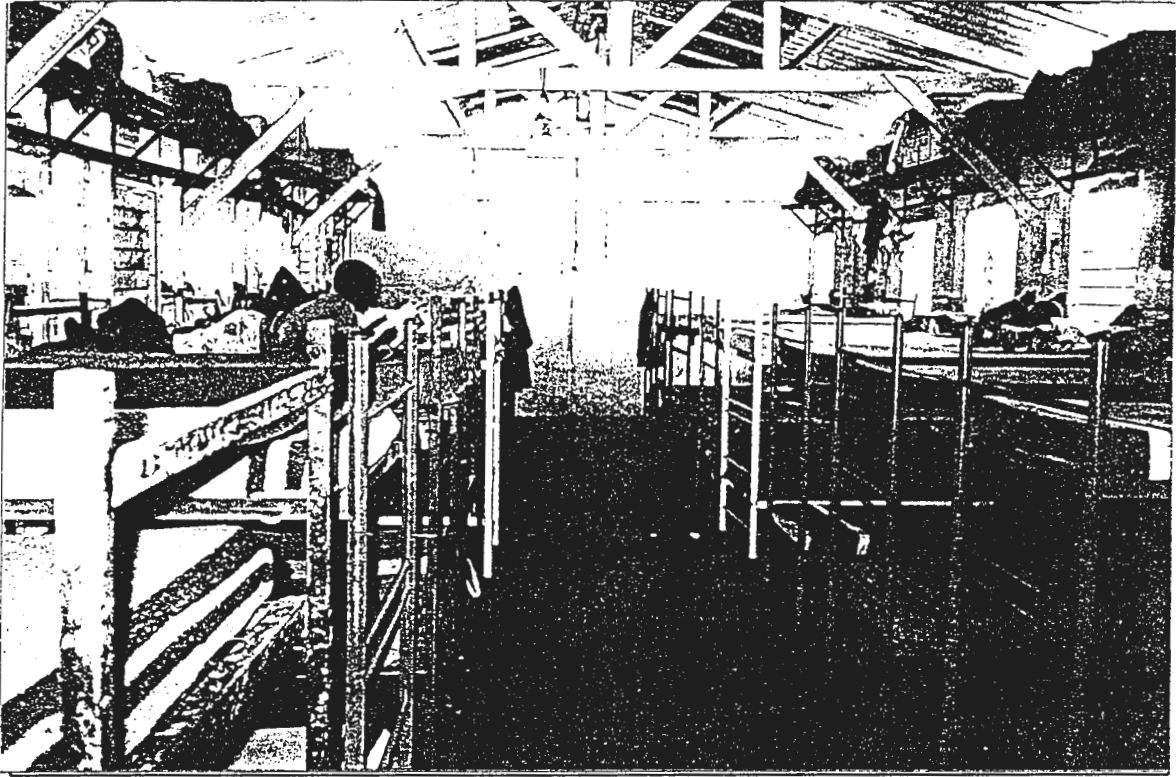

7 - Futungo Shelter: internal view of the sleeping room



8 - Futungo Shelter: view of the two wings of a budget holiday accommodation used as a shelter for street children.

**APPENDIX C**  
**QUESTIONNAIRE FORMS**

**Questionnaire for institutions and professionals working with street children**

Date: \_\_\_/\_\_\_/\_\_\_

Denomination: \_\_\_\_\_

Address: \_\_\_\_\_

Tel: \_\_\_\_\_

Fax: \_\_\_\_\_

Contact MR/MRS: \_\_\_\_\_

Profession: \_\_\_\_\_

Property: \_\_\_\_\_

- Government
- Private
- NGO
- Other (specify) \_\_\_\_\_

Services Provided:

- Sleeping
- Food
- Health Care
- Education
- Entertainment
- Others (specify) \_\_\_\_\_

CHARACTERISTICS:

Architectural typology: \_\_\_\_\_

System of construction: \_\_\_\_\_

Orientation: \_\_\_\_\_

	Good	Average	Bad
--	------	---------	-----

Ventilation:

Natural	<input type="checkbox"/>	<input type="checkbox"/>	<input type="checkbox"/>
---------	--------------------------	--------------------------	--------------------------

Artificial	<input type="checkbox"/>	<input type="checkbox"/>	<input type="checkbox"/>
------------	--------------------------	--------------------------	--------------------------

Lighting:

Natural	<input type="checkbox"/>	<input type="checkbox"/>	<input type="checkbox"/>
---------	--------------------------	--------------------------	--------------------------

Artificial	<input type="checkbox"/>	<input type="checkbox"/>	<input type="checkbox"/>
------------	--------------------------	--------------------------	--------------------------

Development:

Horizontal

Vertical

Mix

Number of floors

(Max/Min): \_\_\_\_\_

Area served (km<sup>2</sup>) \_\_\_\_\_

Total area occupied (site area): \_\_\_\_\_

Area of construction (total floor area) \_\_\_\_\_

Garden area \_\_\_\_\_

Surrounding Area:

Mainly residential

Mainly commercial

Mainly recreational

Mainly industrial

Other (specify)

**CAPACITY**

		Quantity	Total area (m2)		Capacity (specify unit)		OBS
			Min	Max	Min	Max	
	Reception						
	Waiting room						
	Recreation area						
	Eating room						
	Kitchen						
	Workshops						
	Offices						
Health Centre	Reception/R egistration						
	Waiting room						
	Examination						
	Store						
	W.C.						
	Shower/baths						

**STAFF**

How many: \_\_\_\_\_

Principal \_\_\_\_\_

Supervisor \_\_\_\_\_

Social Worker \_\_\_\_\_

Auxiliary workers \_\_\_\_\_

Number of children accommodated \_\_\_\_\_

Remaining places \_\_\_\_\_

Time of permanence \_\_\_\_\_

    Less than 6 months \_\_\_\_\_

    Up to one year \_\_\_\_\_

    Up to two year \_\_\_\_\_

    More than two years \_\_\_\_\_

Have the institution ever refused admission to any child?

Yes  No

If yes Why?

- It was full.
- The institution does not provide the service required.
- Inappropriate sex
- Inappropriate age
- Behaviour problems

Did the institution recommended any other place?

Yes  No

If yes, which one? \_\_\_\_\_

What are the sources of funds:

- Government
- NGO
- Private (your own)
- Community help
- Children's refund
- Other (specify) \_\_\_\_\_

What services do you think are inadequate or lacking in this institution?

Give reasons. \_\_\_\_\_  
\_\_\_\_\_

What do you think that should be improved for better delivery of your services?

\_\_\_\_\_

What do you think about the health care delivery to the street children at the existing facilities.

\_\_\_\_\_  
\_\_\_\_\_

What has been done or should be done about the health care for the street children heathy?

\_\_\_\_\_  
\_\_\_\_\_

What are the special needs related to health care for street children.

\_\_\_\_\_  
\_\_\_\_\_

What is your opinion about the idea of building health facilities to deal exclusively with street children?

\_\_\_\_\_  
\_\_\_\_\_

Where do you think these facilities should be located? Why? \_\_\_\_\_

---

---

What features should distinguish these facilities from the existing health care facilities.

---

Are there any other suggestions or other areas that I should consider in this study?

---

---

Questionnaire for the street children

Date: \_\_\_/\_\_\_/\_\_\_

Name: \_\_\_\_\_  
\_\_\_\_\_

Age: \_\_\_\_\_ Sex:  Male  Female

Place of birth: \_\_\_\_\_

Level of education: \_\_\_\_\_

Place of interview: \_\_\_\_\_

Where are you staying?

- At my parent's home
- At a child welfare shelter
- At a foster parents' house
- On the streets

Have you been to a hospital or visited a physician for the last six months?

- Yes  No

Have you been ill for the last Six months

- Yes  No

If yes how many times? \_\_\_\_\_

Where were you treated?

- At a hospital
- At a health centre
- At a shelter's health centre
- Did not bother
- Other (Specify) \_\_\_\_\_

Approximate period of cure

DISEASE	SLEEPING PLACE	1 TO 2 DAYS	3 TO 4 DAYS	5 TO 6 DAYS	7 AND MORE

How do you classify the health care delivery to the street children at the existing facilities.

- Good
- Average
- Bad

In the following list of health facilities chose one that you should visit preferably if you were sick.

- Health Centre
- Big Hospital for example Maria Pia or S. Paulo
- Shelter's Health Centre
- Health Centre exclusively for street children

Have you ever been refused admission to a hospital or any other health facility?

- Yes  No

If yes, how many times and why? \_\_\_\_\_

What is the main problem do you face to keep you healthy? \_\_\_\_\_

What is your opinion about the idea of building health centres to deal exclusively with street children?

Where do you think these facilities should be located? \_\_\_\_\_

## REFERENCES

- Allen, R. W. and Karolyi. Hospital Planning Handbook New York, a Wiley Interscience Publications, 1976.
- Anneck Rosa C. S.; Borga E. S.; Ebrahim G. J. The Street Children of Recife: a Study of Their Background. Journal of Tropical Pediatrics. 38(1):34-40, Feb 1992.
- Barma, D. and Grennough III, W. B. Cholera. New York, Plenum Publishing Corporation 1992.
- Bhangavan, M. R. Angola's Political Economy 1975 - 1985. Upsala, Scandinavian Institute of African Studies 1986.
- Burman, N. Defining Children: In South African Key Words: the Users and Abuses of Political concepts. Cape Town, Emile Boanzaier & John Sharp, 1988. pp. 167-173.
- Cammock, R. Primary Health Care Buildings: Briefing and Design for Architects and Their Clients. London, The Architectural Press, 1981.
- Cockburn, A. Non Formal Education for Street Children. The Child Care Worker , 6(3):8-10, 1988.
- Cockburn, A. Street Children: An Overview of the Extent, Causes, Characteristics and Dynamics of the Problem. The Child Care Worker, 9(1):12-13, 1991
- Cuthbert, D. L. Money That Mutters: An Introduction to Fundraising in South Africa. Pretoria, J. P. Van Der Walt 1992.
- Deisher, R. W. 2d; Rogers W. M. The Medical Care of Street Youth. Journal of Adolescent Health. 12(7):500-503, Nov 1991.
- Engelhardt, N.L.; Engelhardt, N.L.Jr and Leggett, S. F. W. School Planning and Building Handbook. New York, Dodge Corporation 1956.
- Ennew, J. Children on the Streets. New Internationalist, 164:10-11., 1986.
- Farrow J. A.; Deisher R. W.; Brown R. Kulig J. W.; Kipke M. D. Health and Health Needs of Homeless and Runaway Youth: A Position Paper of the Society for Adolescent Medicine. Journal of Adolescent Health. 13(8):717-726, Dec 1992.
- Gebers, P. E. Health of the Street Children in Cape Town: a Dissertation submitted to the Department of Paediatrics and Child Health of the University of Cape Town for the Degree of M. Med. (Paed). Cape Town: 1990.
- Howard J. Taking a Chance on Love: Risk behaviour of Sydney Street Youth. Journal of Pediatrics and Child Health. 29 Suppl 1:S60-65, 1993.
- Joseph, A. E. and Philips, D. R. Accessibility and Utilization: Geographical Perspectives on Health Care Delivery. New York, Harper & Row Publishers, 1984.
- Keen J. Dealing with Street Children. The Child Care Worker. 8(11):8-9, 1990.
- Kennedy M. R. Homeless and Runaway Youth Mental Health Issues: No Access to the System. Journal of Adolescent Health. 12(7):576-579, Nov 1991.
- Kruks G. Gay and Lesbian Homeless/Street Youth: Special Issues and Concerns. Journal of Adolescent Health. 12(7):515-518, Nov 1991.

- Luna G. C. Street Youth: Adaptation and Survival in the Aids Decade. Journal of Adolescent Health. 12(7):511-514, Nov 1991.
- Miller, P. F. Project Cost Databanks: Working Party Reports. Association of Project Managers in Conjunction with DHSS - Directorate of Works Construction Costs Intelligence. London, Butterworths, 1988.
- Parker R. M.; Rescorla L. A.; Finkelstein J.A.; Barnes N.; Holmes J. H.; Stolley P.D. A Survey of the Health of Homeless Children in Philadelphia Shelters. American Journal of Disease of children. 145(5):520-526, May 1991.
- Peacock, Robert. Street Children. Africa Insight. Vol. 24(2):138, 1994.
- Power, D. Child Health Services in the New South Africa: a Dream. Inaugural Lecture. University of Cape Town, New Series N. 189, 25 May 1994.
- Reuthinger, S. Techniques for Project Appraisal Under Uncertainty. London, the World Bank;, the Johns Hopkins University Press, 1970.
- Ross, C. The Street Children: Survival strategies. Indicator South Africa. 8(4):69 - 72, 1991.
- Sherman D. J. The Neglected Health Care Needs of Street Youth. Public Health Reports. 107(4):433-440, Jul/Ago 1992.
- Scheper-Hughes, N. & Hoffman, D. Kids Out of Place (Part of a Symposium on Poor Children in Latin America). NACLA Report on the Americas. 27:16-23 May/Jun 1994.
- Spring House Corporation. Professional Guide to Disease: an up to Date Enciclopedia of Illness, Disorders, Injuries and Their Treatment. 5th Edition, 1995.
- Wales S. Youth Health: Street Kids in an inner Suburb of Melbourne. Australian Family Physician 20(9):1297-1302, Sep 1991.
- Wright J. D. Kaminsky D. Witting M. Health and Social Conditions of Street Children in Honduras. Taking the next step. American Journal of Disease of children. 147(3):279-283, Mar 1993.
- Wright J. D. Homeless Children. Two Years Later. American Journal Of Diseases of Children. 147(5):518-519, May 1993.
- Yates G. L.; Mackenzie R. G.; Pennbridge J. A Risk Profile Comparison of Homeless Youth involved in Prostitution and Homeless not Involved. Journal of Adolescent Health. 12(7):545-548, 1991.

Yates G. L.; Pennbridge J.; Swofford A.; Mackenzie R. G. The Los Angeles System of Care for Runaway/Homeless Youth. Journal of Adolescent Health. 12(7):555-560, Nov. 1991.

## SELECTED BIBLIOGRAPHY

- Agnelli, S. Street Children: A Growing Urban Tragedy: A report for the Independent Commission of International Issues.ct. London, Weidenfeld & Nicolson, 1986.
- Alperstein G. Homeless Children and Youth: Where are we Heading? Journal of Paediatrics and Child Health. 29(4):245-246, Aug 1993.
- Andrade M. and Oliveira M. The war in Angola: A Socio-Economic Study. Dar-Es-Salam: Tanzania Publishing House, 1975.
- Baizerman, M. Street Kids: Notes for Designing a Program for Youth "of" and "on" the Streets. The Child Care Worker, 6(11):13-15, 1988.
- Balanon, L.G. Street Children: Strategies for Action. Child Welfare, 68(2):159-166, 1989.
- Bernstein, A and Gray M. Khayaletu: An abortive Attempt of Dealing with Street Children. Social Work, 27(1):50-66, 1991.
- Boxil, Nancy A. Homeless Children: the Watchers and the Waiters. New York, The Howorth press, 1990.
- Cemane, K. B. The Street Children Phenomenon. Social Work Practice, (1):2-5, 1990
- Cohen E.; Mackenzie R. G.; Yates G.L. HEADSS, a Psychosocial risk assessment instrument: Implications for Designing Effective Interventions Programs for Runaway Youth. Journal of Adolescent Health. 12(7):539-544, Nov. 1991.
- Commission for Technical Co-operation in Africa South of Sahara. Child Welfare in Africa South of the Sahara: Symposium Organized in Lagos. Nigeria: International Children's Centre, 1959.
- Eisenstein E. Social Imbalance and Health Risks. Journal of Adolescent and Child Health. 29 Suppl 1:s46-49.
- Emden, J. V. and Eastal. J. Report Writing. United Kingdom, Mac Graw-Hill Book Company 1987.
- English, A. Runaway and Street Youth at Risk for HIV Infection Legal and Ethical issues in access to care. Journal of Adolescent Health. 12(7):504-510, Nov 1991
- Fierman A.H.; Dreyer B. P.; Acker P.J.; Legano L. Status of Immunization and Iron Nutrition in New York City Homeless Children. Clinical Pediatrics. 32(3):151-155, 1993 Mar.
- Finkelstein, J. A. and Parker R.M. Homeless children in America. Taking the next step. American Journal of Disease of children. 187(5):520-521, 1993.
- Gesler, W. M. Health Care in Developing Countries. Washington, D.C., Association of American Geographer, 1984.
- Goulart M. and Madover S. An AIDS Prevention Program for Homeless Youth. Journal of Adolescent Health. 12(7):573-575, Nov 1991.
- Gunther, H. Interviewing Street Children in a Brazilian City. The Journal of Social Psychology. 132:359-367, June 1992.
- Konanc, E. Street Children Working in the Street: a Preliminary Results of a Field Study in Turkey, The Child Care Worker, 7(11):13-15, 1989.

- Kleczkowski, B. M. and Nilson, N. O. Health Care Facility Projects in Developing Areas: Planning, Implementation, and Operation. Geneva, The World Health Organization, 1984.
- Letter-Day Peter Pans: But Life is Tough for these Children of the Streets. South African Outlook. 122(182):6-12 Jan/Feb, 1992.
- Mangwana, T. Rural Initiatives in Dealing with Street Children. The Child Care Worker, 9(7):13, 1991.
- Martins S. B. and Ebrahim G. J. Street Children. Journal of Tropical Pediatrics. 39(5):264-268, Oct 1993 .
- Page A. J.; Ainsworth A. D.; Pett M. A. Homeless Families and Their Health Problems: A Utah Urban Experience. Western Journal of Medicine. 158(1):30-35, Jan 1993.
- Reuler J. B. Outreach Health Services for Street Youth. Journal of Adolescent Health. 12(7):561-566, Nov 1991.
- Richter, L. M. Street Children: The Nature and Scope of the Problem in Southern Africa, The Child Care Worker, 6(7):11-13, 1988.
- Richter, L. M. Street Children in South Africa: Street Children in Rich and Poor Countries. The Child Care Worker, 9(9):5-7, 1991.
- Rosenfield, Isadore. Hospital Integrated Design. New York: Reinhold Publishing, 1947.
- Smart, D. H. Homeless Youth in Seattle: Planning and Policy-Making at the Local Government Level. Journal of Adolescent Health 12(7):519-527, 1991.
- Tenbrunsel, T. W. The fund raising Resource Manual. New Jersey: Prentice- Hall 1982.
- Upshur, C. C. How to set Up and Operate a Non-Profit Organization. New Jersey, Prentice-Hall, 1982.
- Wakhweya A. M. Health Care in Africa: Which Way. Medicine and War. 9:234-241,1993.
- Williams C. Who Are "Street Children": A Hierarchy of street use and Appropriate Response. Child Abuse & Neglect. 17(6):831-841, Nov/Dec 1993.
- Wright J. D. Children in and of the Streets. Health, Social Policy, and the Homeless Young. American Journal of Diseases of Children. 145(5):516-519; May 1991.