

NANTU POTTERY OF SOUTHERN AFRICA

by

Anne Lawton

VOLUME II.

The University of Cape Town has been given the right to reproduce this thesis in whole or in part. Copyright is held by the author.

The copyright of this thesis vests in the author. No quotation from it or information derived from it is to be published without full acknowledgement of the source. The thesis is to be used for private study or non-commercial research purposes only.

Published by the University of Cape Town (UCT) in terms of the non-exclusive license granted to UCT by the author.

TABLE OF CONTENTS

VOLUME II.

DESCRIPTION OF FIGURES

FIGURES

PLATES

MAPS

University of Cape Town

LIST OF FIGURES

FIGURE:

POTTERY:

I	CAPE NGUNI
II	CAPE AND IMMIGRANT CAPE NGUNI
III-VII	NATAL NGUNI
VIII	SWAZI
IX	TRANSVAAL AND RHODESIAN NDEBELE
X	RHODESIAN NDEBELE
XI	RONGA
XII	NELANGANU, TSHANGANA AND NKUNA
XIII	HLENOWE
XIV	TSWA
XV	TSONGA
XVI-XXI	MASUTO
XXII-XXIII	WESTERN TSWANA
XXIV	WESTERN TSWANA AND TSWANA (undifferentiated)
XXV	WESTERN AND EASTERN TSWANA AND KALANGA
XXVI	WESTERN TSWANA AND KALANGA
XXVII-XXVIII	WESTERN TSWANA
XXIX-XXXI	TSWANA (undifferentiated)
XXXII-XXXIV	EASTERN TSWANA
XXXV	CENTRAL SOTHO AND NORTHERN SOTHO (undifferentiated)
XXXVI	CENTRAL SOTHO AND SOTHO (undifferentiated)
XXXVII	CENTRAL SOTHO AND NORTHERN SOTHO
XXXVIII	CENTRAL SOTHO
XXXIX	NORTHERN SOTHO AND CENTRAL SOTHO (made by Swasi)
XXXX-XXXXII	NORTH EASTERN SOTHO

<u>FIGURE:</u>	<u>POTTERY:</u>
XXXIII	NORTHERN SOTHO
XXXIV	NORTHERN SOTHO AND SOTHO (undifferentiated)
XXXV	CENTRAL SOTHO
XXXVI	NORTHERN SOTHO (undifferentiated)
XXXVII-XXXVIII	VENDA
XXXIX-L	VENDA AND LEMBA
LI	VENDA
LII-LIII	LEMBA
LIV	CHOPI
LV-LVI	BITONGA
LVII-LXVI	SEONA
LXVII	AMBO
LXVIII	NORTHERN AMBO
LXIX	NORTHERN AND SOUTHERN AMBO
LXX	EASTERN AMBO
LXXI	? DIRIKO
LXXII	EASTERN AMBO AND DIRIKO
LXXIII-LXXIV	MPUKUSHU
LXXV	HERERO

POTTERY ILLUSTRATIONS CLASSIFIED ACCORDING TO TRIBAL GROUP

1. NGUNI

11. CAPE NGUNI:
Npondo Nos. 1-7
12. IMMIGRANT CAPE NGUNI
Bhaca No. 8
13. NATAL NGUNI
Basuto made No. 28
Mabaso Nos. 11,12,15,19,20,21,23.
Mamteto No. 17
? Matshabane No. 29
Undifferentiated Nos. 9,14,16,18,24,25-27
? Ximba Nos. 10,22
Zulu No. 13
14. SWAZI
undifferentiated Nos. 30-36
16. NORTHERN TRANSVAAL NDEBELE
undifferentiated No. 37
18. RHODESIAN NDEBELE
undifferentiated Nos. 38-44

2. TSONGA

21. SOUTHERN TSONGA (RONGA)
undifferentiated Nos. 45-51
22. NHLANGANI
undifferentiated No. 52
23. TSHANGANA
Mozambique No. 53
24. NKUNA & OTHERS IN TRANSVAAL
Nkuna No. 54
25. NORTHERN TSONGA
Hlongwe Nos. 55-62
Tsva Nos. 63-65
undifferentiated (Mozambique) Nos. 66-68

3. SOTHO

31. SOUTHERN SOTHO (BASUTO)
Pekeng Nos. 87,89,90,95,97,100,101
Eiakvana No. 94
Kvena Nos. 93, 105
Swazi made: No. 76
undifferentiated Nos. 69-75, 77-86, 88. 92. 96, 98,99,
102-04, 106
32. WESTERN TSWANA
Huruthse No. 117
Kalanga Nos. 109,122,123.
Kralaxadi Nos. 119,124
Mangwato Nos. 107, 108, 125-128, 130
Malote Nos. 120,121
Ngwaketse Nos. 110-114, 116

32. WESTERN TSWANA (continued)
 Tlaping Nos. 118,129,131
33. EASTERN TSWANA
 Kgatla Nos. 138-140, 142, 143, 145
 Kvena ba Mogopa Nos. 141
 Tlokwa No. 144
 TSWANA (Undifferentiated)
 Nos. 115, 132,137
34. CENTRAL SOTHO
 Pedi 151, 159-162
 Pedi made by Swazi 156, 163-165
 Undifferentiated Nos. 147-49, 152-155, 157
36. NORTH-EASTERN SOTHO
 Lobedu Nos. 167,182
37. NORTHERN SOTHO
 Hananwa Nos. 183-87, 189
 Koni Nos. 190, 191
 Kvena/Moletse Nos. 158, 166
 Undifferentiated Nos. 150, 188, 192-200

4. VENDA AND 5. LEMBA

41. WESTERN VENDA Nos. 202, 203, 206, 207, 212, 214, 217-19, 220
 222-225
44. EASTERN VENDA Nos. 208, 210, 216
47. SOUTHERN VENDA Nos. 205
 Undifferentiated Nos. 201, 204, 209, 211, 221
51. LEMBA
 In Transvaal: Nos. 213,215,227,228, 232-237
 In Rhodesia: Nos. 226,229, 230, 231

6. CHOPI

61. CHOPI
 Lenge Nos. 239,240
 Khokha(BiTonga) Nos. 241-244
 Undifferentiated Nos. 238,239.

7. SHONA

71. KARANGA
 Barve Nos. 269
 Budjga No. 267
 Karanga Nos. 256-258,260,263,264,270,293,294
 Mbere Mbere Nos. 259,261
 Manyika Nos. 266,284,285.
 Mari No. 250
 Romo Nos. 248,278,283,295,296
 Shawasha No. 268
 Tonga Nos. 245,254,262,271,275,281,297

72. ROSWI

Roswi Nos. 290,291

Ndau Nos. 280,282, ~~288~~,289,292.

Undifferentiated: Nos. 246,247-249,251-253,255,272-274,276,277.

8. HERERO

8. HERERO

Undifferentiated Nos. 329-331

9. AMBO

91. NORTHERN AMBO

Kwanyama Nos. 303-308

92. SOUTHERN AMBO

Kolonkathi Nos. 310-313

Kualuthi Nos. 309,311

Kwankwa Nos. 319,321

93. EASTERN AMBO

Kuangari Nos. 315-317, 320,322

10. OKAVANGO TRIBES

101. MPUKUSHU

Nos. 314,325-328

102. DIRIKO

Nos. ? 318,323,324

LIST OF PLATES

<u>PLATE:</u>	<u>NO:</u>	
I	1-2	Bomvana pottery
II-IV	3-8	Mpondo pottery
V-VI	9-11	Xesibe pottery
VII	12	Mabaso pottery
VII-VIII	13-16	Swazi pottery
IX	17-19	Swazi: Spiral technique
X-XI	20-25	Ronga: Moulding from the lump
XII-XIII	26-31	Nkana: Ring technique
XIV	32	Tswa: Potter at work
XIV	33	Bifonga pot used by Tswa
XV	34-35	Basuto pottery
XV	36	Basuto: Potter at work
XVI	37-40	Basuto firing
XVII	41	Mangwato pot
XVII	42	Kalanga, Bechuanaland
XVII	43-44	Kgatla pottery
XVIII-XIX	45-52	Tlokwa: Building from the widest diameter
XX	53	Kgatla pottery
XX	54-55	Pedi pottery made by Swazi potters
XX	56	Swazi, Sekhukhuneland. Position of pots for firing.
XXI	57	Lemba pot
XXI	58-59	Venda pottery
XXI-XXII	60-64	Lemba: Moulding from the lump
XXIII	65-66	Bifonga pottery

<u>PLATE:</u>	<u>NO:</u>	
XXIII	67-68	Manyika pottery
XXIV	69	Roswi pottery
XXIV	70	Zezuru pottery
XXIV	71	Teva pottery
XXIV	72	Mari : Potter at work
XXV	73	Karanga, Rhodesia.
XXV	74	Ndeu: Starting a pot in ring technique
XXV	75	Kwanyama: Underground workroom
XXV	76	Mpukushu pot

University of Cape Town

ABBREVIATIONS

AFRIK.	Africana Museum, Johannesburg
BLN.	National Museum, Bloemfontein
BM.	British Museum, London
BWYO.	National Museum, Bulawayo
CAM.	Cambridge University Museum of Archaeology and Ethnology
COP.	National (Ethnographic) Museum, Copenhagen
EL.	East London Museum, East London
HAM.	Museum für Völkerkunde, Hamburg
PAR.	Musée de l'Homme, Paris
PITT R.	Pitt Rivers Museum, Oxford
Q.V.M.M.	Queen Victoria Memorial Museum, Salisbury (used by Schofield)
SAL.	Queen Victoria Museum, Salisbury
SAH.	South African Museum, Cape Town
TVL.	Transvaal Museum, Pretoria
UCT.	University of Cape Town collection, on permanent loan to South African Museum, Cape Town
WIND.	State Museum, Windhoek
WITS.	Department of Social Anthropology and African Adminis- tration, University of the Witwatersrand, Johannesburg.

DESCRIPTIONS OF ILLUSTRATED POTTERY VESSELS

The pottery illustrations have been arranged according to tribal sub-divisions and within that grouping, as far as possible according to the type of vessel, depending upon space. Pottery in the Natal Nguni tradition, manufactured by potters of another tribal group has been grouped with Natal Nguni pottery, and pottery in the Pedi tradition made by Swazi potters is grouped with pottery of Central Sotho manufacture.

In setting out the descriptive data and available information concerning use and vernacular name of each vessel, the scheme set out below has been followed. Headings are omitted in cases where no relevant information is available.

NUMBER OF FIGURE: NUMBER OF VESSEL ILLUSTRATION

MUSEUM NUMBER: TRIBE, Locality, Date of Collection or Donation, Collector.

SHAPE: Body, neck, rim, base and height (referred to as H.)

WARE: General impression of workmanship, for example, thickness of pottery wall and weight of vessel compared with size, degree of skill exercised in manufacture, natural colour of vessel after firing, degree of firing (the method of judging this being based upon that used by Bantu potters themselves, i.e. by tapping the vessel so that it reverberates, the higher the sound the better fired the pot is believed to be).

DECORATION: graphic, colour, and general standard of execution.

USE: - (source of information)

NAME: - (source of information)

Where museum records are given as the source of information this refers to the records of the museum where the vessel is housed and indicates that it is not known from whom the information was obtained.

An "x" beside an illustration denotes use of synthetic decorative materials. An "p" beside an illustration denotes the drawing of a vessel from measurements and sketches made during the examination of pottery collections in museums only briefly visited, others drawings were made with reference to the specimens themselves.

Figure I No. 1

SAM 6051 MPONDO Umvuse Springs, Pondoland. June 1939. Mrs. Clarke.

Shape: Bag-shaped pot with short, straight everted neck, formed with well-defined point of inflection, cut rim and flattened base. H 21.3cms.

Ware: Heavy ware of medium thickness. Roughly formed neck. Very well fired. Natural colour of the fired clay brown.

Decoration: Band of stamped impressions around neck. Red ochre applied on the outer surface below neck and on inner surface on neck. Burnished.

Use: "a container for small allowances of food-stuffs, like sprouted grain of "amerewu"; which is used in beer-making." (Mrs. Clarke - museum records)

Name: inkonga (Mrs. Clarke - museum records)

Figure I No. 2

UCT 32/37 MPONDO Holy Cross, Flagstaff, E. Pondoland. June 1932. D.R. Krummeck.

Shape: Barrel-shaped pot with cut rim and flattened base. H 15.5cms.

Ware: Medium weight pottery, evenly formed but not well fired.

Decoration: Designs of stamped impressions made with the end of a grass stalk. Outer surface and small area inside mouth of vessel smeared rather unevenly with a dark reddish ochre and lightly burnished.

Use: beerpot (museum records)

Name: ingqavi (museum records)

Figure I No. 3

SAM 6167 MPONDO Ngqeleni District, Transkei. July 1940 (Industrial school work)

Shape: Spherical pot with rounded rim and projecting base. H 15.5cms.

Ware: Very heavy pottery, poorly shaped, with smooth finish. Very well fired.

Decoration: Broken band of impressions stamped with the end of a grass stalk around neck. Coloured with reddish ochre and lightly burnished.

Figure I No. 4

UCT 32/37 MPONDO Holy Cross, Flagstaff, E. Pondoland. June 1932. D.R. Krummeck.

Figure I No. 4 (continued)

- Shape: Barrel-shaped pot with out rim and flattened base. H 16.2cms.
- Ware: Medium weight pottery, evenly formed but not very well fired.
- Decoration: Two bands of moulded decoration, one below the rim and the other halfway down the vessel. Outer surface and small area inside mouth of vessel smeared rather unevenly with a dark reddish ochre and lightly burnished.
- Use: beerpot (museum records)
- Name: inggayi (museum records)

Figure I No. 5

- SAM 6168 MPONDO Ngqeleni District, Transkei. July 1940 (Industrial school work)
- Shape: Spherical pot with rounded rim and four rudimentary legs. H 16.75cms.
- Ware: Very thick, heavy ware, well smoothed surface Well fired.
- Decoration: Designs of stamped impressions made with the end of a grass stalk. Red ochre applied outside and over small area inside the mouth, lightly burnished.

Figure I No. 6

- SAM 6167 MPONDO Ngqeleni District, Transkei, July 1940 (Industrial school work)
- Shape: Spherical pot with rounded rim and projecting base. H 15.5cms.
- Ware: Very heavy pottery, poorly shaped, with exterior surface well smoothed. Well fired.
- Decoration: Bands of slits approximately 1.5cms long made with a sharp blade at an acute angle to the surface. Coloured with reddish ochre and lightly burnished.

Figure II No. 7

- SAM 7385 MPONDO near Umzanda River Mouth, Bizana District, Transkei. April 1955. Ethnologist, South African Museum
- Shape: Large barrel-shaped pot with rounded rim and flattened base. H 32cms.
- Ware: Well formed pottery of medium thickness. Surface well smoothed but shows small

Figure II No. 7 (continued)

Ware: irregularities in the clay. Well fired ware, a reddish brown colour with black base.

Figure II No. 8

SAM 6986 BHACA Mount Frere, Transkei. October 1948 Cornner.

Shape: Barrel-shaped pot with upright neck formed with poorly-defined point of inflection, thickened rim and flattened base. H 23.5 cms.

Ware: Well formed, fairly thin ware. Well smoothed both inside and out. Well fired.

Decoration: Five small lumps applied around the base of the neck. Vessel blackened by firing, probably deliberate, and well burnished.

Figure III No. 9

SAM 8438 ZULU Table Mountain, Pietermaritzburg, Natal. April 1961. Bought by South African Museum Expedition at Durban Market.

Shape: Spherical pot with cut rim and flattened base. H 19.5cms.

Ware: Well formed, thick heavy ware. Smoothed inside and outside. Fired red with smokey patches. Well burnished outside.

Decoration: Two designs of three triangles filled with half-moon impressions, probably made with the finger-nail, opposite each other.

Use: beerpot (seller)- museum records

Name: ukhamba (seller)- museum records.

Figure III No. 10

SAM 8414 Zulu (? XIMBA - van Warmelo 1935) Mahlabatini, Zululand, April 1961. South African Museum Expedition.

Shape: Small inverted bag-shaped pot with cut rim and flattened base. H 10cms.

Ware: Thick heavy pottery. Poorly fired.

Decoration: Decorative band patterned with multiple grooves around the upper section of the vessel. Deliberately blackened by firing and highly burnished.

Use: Drinking beer (seller)- museum records.

Name: umancishane (seller)- museum records.

Figure III No. 11

SAM 8425 MABASO Tugela Ferry, Msinga District, Natal. April 1961. South African Museum Expedition.

Shape: Spherical pot with rounded rim and flattened base. H 13cms.

Ware: Fairly light ware. Very symmetrical. Well fired.

Decoration: Modern "flower" design in lightly grooved lines. Deliberately blackened in a reducing atmosphere and well burnished.

Use: beerpot (potter - museum records)

Name: ukhamba (potter - museum records)

Figure III No. 12

SAM 8427 MABASO Tugela Ferry, Msinga District, Natal. April 1961. South African Museum Expedition.

Shape: Inverted bag-shaped pot with rounded rim and flattened base. H 16.5cms.

Ware: Pottery of medium thickness, smoothed inside and out with the exception of the base.

Decoration: Designs grooved with a hairpin. Blackened in a reducing atmosphere and highly burnished.

Use: beerpot (potter - museum records)

Name: ukhamba (potter - museum records)

Figure III No. 13

SAM 8403 ZULU Eshowe, Zululand. April 1961 South African Museum Expedition.

Shape: Bag-shaped pot with cut rim and flattened base. H 17cms.

Ware: Fairly heavy pottery, evenly formed with a smooth finish.

Decoration: Spaced asymmetrical designs of triangular stamped impressions. Black finish. Well burnished.

Use: beerpot (seller - museum records)

Name: ukhamba (seller - museum records)

Figure III No. 14

SAM 8803 ZULU Msinga District, Natal. 1936 Government Ethnologist. Presented to the South African Museum in September 1962.

Figure III No. 14 (continued)

- Shape: Spherical pot with rounded rim and flattened base. H 14cms.
- Ware: Thin light pottery, very well shaped. Well fired.
- Decoration: Two concentric bands of applied rounded lumps. Vessel blackened and burnished.
- Use: small container for beer (Doke, Malcolm and Sikakana 1958)
- Name: umancishane (Gov. Ethnologist - museum records)

Figure III No. 15

- SAN 8426 NABASO Tugela Ferry, Msinga District, Natal, April 1961. South African Museum Expedition
- Shape: Sub-spherical pot with rounded rim and flattened base. H 16.5cms.
- Ware: Thin, light-walled ware with heavier base. Well fired.
- Decoration: Zig-zag designs in shallow grooved lines. Base is cross-hatched with incised lines. Blackened in reducing atmosphere. Well burnished.
- Use: beerpot (potter - museum records)
- Name: ukhamba (potter - museum records)

Figure III No. 16

- SAN 8797 ZULU Msinga, Natal, 1936. Government Ethnologist. Presented to the South African Museum in September 1962
- Shape: Spherical pot with cut rim and flattened base. H 17cms.
- Ware: Very thin walled light ware. Well formed. Fair firing.
- Decoration: Spaced groups of round stamped impressions. Highly burnished black finish.
- Use: Family beerpot for serving beer (Gov. Ethnologist - museum records)
- Name: ukhamba (Gov. Ethnologist - museum records)

Figure IV No. 17

- SAN 8396 MAMTETO Eshowe, Zululand. April 1961 South African Museum Expedition.
- Shape: Sub-spherical pot with cut rim and flattened base. H 26.75cms.

Figure IV No. 17 (continued)

Ware: Fairly heavy ware with noticeably heavy base. Well shaped.

Decoration: Decorative band patterned with multiple grooving. Black finish, lightly burnished.

Use: beer or water pot (potter - museum records)

Name: ukhamba (potter - museum records)

Figure IV No. 18

UCT 38/16 ZULU no locality given. Schapera.

Shape: Deep open mouthed bowl with cut rim and flattened base. H 14cms.

Ware: Thin light ware. Well shaped. Not very well fired. Interior a reddish black, exterior black and burnished.

Figure IV No. 19

SAM 8433 MABASO Tugela Ferry, Msinga District, Natal. April 1961. South African Museum Expedition

Shape: Inverted bag shaped pot with everted neck formed with poorly defined point of inflection, rounded rim and flattened base. H 32.3cms.

Ware: Well shaped ware of even thickness. Fairly heavy. Very well fired.

Decoration: Modern "flower" design in grooved lines Black finish, well burnished.

Use: storing beer or water (potter - museum records)

Name: ingcazi (potter - museum records)

Figure V No. 20

SAM 8435 MABASO Tugela Ferry, Msinga District, Natal. April 1961. South African Museum Expedition

Shape: Sub-spherical pot with cut rim and flattened base. H 24.25cms.

Ware: Fine, thin walled, light weight ware. Centre of biscuit brown, outside black.

Decoration: Grooved designs. Black burnished finish.

Use: beerpot (potter - museum records)

Name: ukhamba (potter - museum records)

Figure V No. 21

SAM 8434 MABASO Tugela Ferry, Msinga District, Natal. April 1961. South African Museum Expedition

Figure V No. 21 (continued)

Shape: Widemouthed inverted bag-shaped pot with cut rim and flattened base. H 18cms.

Ware: Thin-walled ware with heavy base. Very well shaped. Fair firing.

Decoration: Burnished black finish.

Name: ukhamba (seller - museum records)

Figure V No. 22

SAM 8415 ZULU (? XIMBA - van Warmelo 1935)
Mahlabatini, Zululand. April 1961 South African
Museum Expedition.

Shape: Spherical pot with cut rim and flattened base. H 12.3cms.

Ware: Heavy pottery with thick base. Well formed. Poor firing. Brick red biscuit:

Decoration: Triangular design of raised moulded lumps. Black finish, very well burnished.

Use: drinking beer (seller - museum records)

Name: umancishane (seller - museum records)

Figure V No. 23

SAM 8424 MABASO Tugela Ferry, Msinga District,
Natal. April 1961. South African Museum Expedition

Shape: Inverted bag-shaped pot with cut rim and flattened base. H 29.5cms.

Ware: Heavy pottery. Well formed. Fair firing.

Decoration: Grooved designs. Fired in a reducing atmosphere to give a black finish.

Use: beerpot (potter - museum records)

Name: ukhamba (potter - museum records)

Figure VI No. 24

AFRIK 58/1648 ZULU

Shape: Pot with cut rim and flattened base.
H 20.1cms.

Decoration: Stamped arcs of a circle. Black finish.

Figure VI No. 25

TVL 8313 ZULU Msinga District, Natal.

Shape: Bag-shaped pot with flattened base. H 13.5cms.

Ware: Thin walled ware.

Decoration: Design in applied lumps around upper section of the vessel. Black finish.

Figure VI No. 25 (continued)

Use: small beerpot (museum records)

Name: umancishane (museum records)

Figure VI No. 26

TVL 13 ZULU

Shape: Tall barrel-shaped pot with cut rim and flattened base. H 22cms.

Ware:

Decoration: Designs stamped with the head of a nail.

Use: milking (museum records)

Figure VI No. 27

TVL 16 ZULU Purchased from Ivy.

Shape: Tall barrel-shaped pot with cut rim and flattened base. H 24cms.

Ware: Fired black with orange patches.

Use: Milking and other household purposes. (museum records)

Figure VI No. 28

SAM 8983 BASUTO in Zulu style. Nqutu, Zululand. 1963. Ethnologist, South African Museum.

Shape: Spherical pot with cut rim and flattened base. H 17.3cms.

Ware: Well formed, heavy-based ware. Fair firing

Decoration: Design patterned with very fine multiple grooving. Black, burnished finish

Figure VII No. 29

SAM 8642 ZULU (? MATSHABANE - van Warmelo 1935)

Shongwe Store, Ubombo District, Natal.

Shape: Sub-spherical pot with rounded rim and rounded base. H 34cms.

Ware: Thin walled ware. Well fired.

Decoration: Triangular design in shallow round stamped impressions.

Use: beer or water pot (potter- museum records)

Name: imbiza (potter - museum records)

Figure VIII No. 30

SAM 8677 SWAZI Hora Valley, Pigg's Peak, Swaziland. June 1962 South African Museum Expedition.

Figure VIII No. 30 (continued)

Shape: Open-mouthed bowl with rounded rim and flattened base. H 11cms.
Ware: Thick red ware, smoothed inside and out. Fair firing.
Decoration: Lightly burnished on the outside.
Use: food bowl (potter - museum records)
Name: umkhele (potter - museum records)

Figure VIII No. 31

SAM 8646 SWAZI Hlatikulu District. Swaziland. June 1962 South African Museum Expedition.
Shape: Spherical pot with cut rim and flattened base. H 18cms.
Ware: Fairly thin-walled ware. Well fired. Smoothed inside and out.
Decoration: Diamond-shaped designs patterned with stamped impressions made with the end of a grass stalk. Black finish with patches of red.
Use: beer container (potter - museum records)
Name: lukhamba (potter - museum records)

Figure VIII No. 32

SAM 6040 SWAZI Sekhukhuneland, Transvaal. 1939
Shape: Small open-mouthed bowl with cut rim and flattened base. H 7.1cms.
Ware: Thick pottery. Fired to a black/brown colour. Well fired.
Decoration: Burnished on the outside.
Use: porridge bowl (Venter in lit April 1964)
Name: morusoana oa godjela (museum records)

Figure VIII No. 33

SAM 8647 SWAZI Hlatikulu, Swaziland. June 1962. South African Museum Expedition.
Shape: Small spherical pot with cut rim and flattened base. H 14.1cms.
Ware: Well shaped fairly thin ware. Well fired. Smoothed inside and out.
Decoration: Two wavy lines of stamped impressions made with the end of a grass stem. Black surface burnished on the outside.
Use: beer container (seller - museum records)
Name: lukhamba (seller - museum records)

Figure VIII No. 34

SAM 8652 SWAZI Hlatikulu District, Swaziland. June 1962. South African Museum Expedition.

Shape: Sub-spherical pot with slight inward sloping neck formed with poorly defined point of inflection; rounded rim and flattened base. H 18cms.

Ware: Well formed medium thick walled ware. Well fired. Black/red colour. Smoothed inside and outside.

Decoration: Fair burnish on the outside.

Name: ludziwo (seller)

Figure VIII No. 35

SAM 8666 SWAZI Mbabane Market, Mbabane, Swaziland June 1962 South African Museum Expedition.

Shape: Small spherical pot with out rim and slightly flattened base. H 12cms.

Ware: Thin walled, well shaped, light weight ware Light buff inside.

Decoration: Applied lumps. Blackened with smoke.

Figure VIII No. 36

SAM 8665 SWAZI Mbabane Market, Mbabane, Swaziland June 1962 South African Museum Expedition.

Shape: Bagshaped pot with out rim and flattened base. H 23cms.

Ware: Well formed pot. Medium thick, Very well fired. Black ware with buff patches. Smoothed inside and outside.

Decoration: Burnished on the outside.

Figure IX No. 37

TVL 61/160 TVL. NDEBELE Grasvlei, Potgietersrust, Transvaal.

Shape: Inverted bag-shaped pot with thickened rim and rounded base. H 25cms.

Decoration: Stamped design filled in with white material. Graphite and red ochre.

Use: drinking beer and water at home (museum records)

Name: notsegana (museum records)

Figure IX No. 38

BWYO 2059 NDEBELE Tjabezi Valley, Matopo Hills. S. Rhod.

Shape: Bagshaped pot with flattened base and round rim. H 25.5cms.

Use: old pot, probably last used for storing purposes. (museum records)

Figure IX No. 39

BWYO 2059 NDEBELE Tjabezi Valley, Matopo Hills,
S. Rhod.

Shape: Pot with upright neck formed with poorly-
defined point of inflection, rounded rim
and rounded base. H 16.5cms.

Ware:

Decoration: Incised line around the base of the
neck.

Use: old pot, probably last used for storing
purposes. (museum records)

Figure X No. 40

SAN 1344 MATABELE Empandeni, near Plumtree,
S. Rhod. 1911 O'Neill.

Shape: Spherical pot with upright neck formed
with poorly-defined point of inflection,
flattened thickened rim and rounded
base. H 15.5cms.

Ware: Thick heavy ware, smoothed inside and out
Well fired.

Decoration: Two very deep incised lines forming
a wide zig-zag band. Graphite, red ochre
and a white material used as colour.
No burnish.

Figure X No. 41

SAN 1344 MATABELE Empandeni, near Plumtree, S.
Rhod. 1911 O'Neill

Shape: Spherical pot with upright neck formed with
poorly-defined point of inflection, flatten-
ed thickened rim and rounded base. H 16.4
cms.

Ware: Well shaped ware of medium thickness and
weight. Well fired to a brown buff colour.
Smooth unburnished surface.

Decoration: Two bands of incised triangles coloured
with white material with band of cross
hatching between them. Applied red ochre
and graphite, lightly burnished.

Figure X No. 42

SAN 1344 MATABELE Empandeni, near Plumtree, S. Rhod.
1911 O'Neill.

Figure X No. 42 (continued)

Shape: Spherical pot with upright neck formed with poorly-defined point of inflection, flattened thickened rim and rounded base. H 21.1 cms.

Ware: Medium heavy ware. Smoothed inside and out.

Decoration: none

Figure X No. 43

BWYO 2025 NDEBELE Bazha, Motokos, S. Rhod.

Shape: Spherical pot with curved everted neck formed with poorly defined point of inflection, rounded rim and flattened base. H 15cms.

Ware: Very roughly finished, poorly formed ware.

Decoration: Application of red ochre, very poor burnish.

Figure X No. 44

BWYO 1996 NDEBELE (Made by Kalanga who have been absorbed by the Ndebele) Essexvale, S. Rhod.

Shape: Pot with upright neck formed with poorly-defined point of inflection and flattened base. H 22cms.

Ware: Very poorly formed ware.

Decoration: Incised design patterned with stamped impressions made with a very sharp stylus. Band of red ochre below the mouth.

Figure XI No. 45

SAH 8787 RONGA Vila Luiza, Lourenco Marques, Sul do Save, Mozambique. September 1962. South African Museum Expedition.

Shape: Wide-mouthed shallow carinated bowl with short straight everted neck formed with well-defined point of inflection, flattened rim and rounded base. H 14 cms.

Ware: Well formed light weight pottery of medium thickness. Matt finish to both inner and outer surfaces.

Decoration: Very rough burnish on the outer surface for a short distance above and below the carination.

Use: for cooking relish (potter - museum records)

Notes: inhlabeto (potter - museum records)

do

Ware:

Shape:

Figure XI No. 46

SAM 8788 BONGA Vila Luiza, Lourenco Marques, Sul do Save, Mozambique. September 1962. South African Museum Expedition.

Shape: Sub-carinated pot with upright neck formed with poorly defined point of inflection, thickened rim and flattened base. H 11.2cms.

Ware: Thin-walled, light pottery.

Decoration: Red colour applied to outer surface and lightly burnished.

Use: used by the man of the house for drinking beer (seller - museum records)

Name: lekhumana (seller - museum records)

Figure XI No. 47

SAM 8917 BONGA Vila Luiza, Lourenco Marques, Sul do Save, Mozambique. June 1963. South African Museum Expedition.

Shape: Small widemouthed sub-carinated bowl with short, curved everted neck formed with poorly-defined point of inflection, rounded rim and rounded base. H 12.5cms.

Ware: Unevenly shaped pottery of medium thickness and weight. Matt finish inside and out. Well fired to a red buff colour with black patches.

Decoration: Band of stamped rolled impressions done with the edge of a bivalve shell.

Figure XI No. 48

SAM 8786 BONGA Vila Luiza, Lourenco Marques, Sul do Save, Mozambique. September 1962. South African Museum Expedition.

Shape: Widemouthed sub-carinated bowl with short straight everted neck formed with a well-defined point of inflection, out rim and rounded base. H 11.4cms.

Ware: Unevenly shaped pottery of medium thickness. Very light in weight and very well fired. Matt finish inside and out.

Use: cooking relish (potter - museum records)

Name: inhambato (potter - museum records)

Figure XI No. 49

SAM 8785 BONGA Vila Luiza, Lourenco Marques, Sul do Save, Mozambique. September 1962. South African Museum Expedition.

Shape: Deep widemouthed bowl with carination at the base of tall, curved everted neck, rounded rim and rounded base. H 17.00cms.

Figure XI No. 49 (continued)

Ware: Thin, light, well-shaped ware. The area above the carination has been smoothed more than that below it. Mat surface with small stones visible on the surface of the fired clay. Very well fired.

Decoration: Band of short lines of stamped impressions around the carination.

Use: cooking porridge (potter - museum records)

Name: inhlabete (potter - museum records)

Figure XI No. 50

SAM 8916 RONGA Vila Luiza, Lourenco Marques, Sul do Save, Mozambique. June 1963. South African Museum Expedition.

Shape: Deep, widemouthed bowl with carination at the base of tall compound everted neck, rounded rim and rounded base. H 18cms.

Ware: Evenly shaped pottery of medium thickness and weight. Mat finish inside and out. Very well fired. Colour buff and black patches.

Decoration: Band of short lines of stamped impressions made with the edge of a bivalve shell around the carination.

Use: cooking porridge (potter - museum records)

Name: inhlabete (potter - museum records)

Figure XI No. 51

WITS 39/523 RONGA Ricatla, Lourenco Marques, Sul do Save, Mozambique. 1909 (Said to belong to Sokis, a witchdoctor.)

Shape: Sub-carinated pot with upright neck formed with poorly-defined point of inflection, rounded rim and rounded base. H 13.75cms.

Ware: Fired a red-brown colour.

Decoration: none

Use: Said to have been on Sokis's grave. Offerings of beer made to him by his wife. Hole in the base of the vessel. (museum records)

Figure XII No. 52

SAM 8906 NHLANGANU Alexandria Farm, Bushbuckridge Transvaal. May 1963. South African Museum Expedition

Shape: Spherical pot with inward sloping neck formed with poorly-defined point of inflection, cut rim and rounded base. H 24.5cms.

Ware: Thick heavy pottery, fairly evenly formed. Well fired. Natural colour of the fired ware buff with black patches.

FIGURE

Figure XII No. 52 (continued)

Decoration: Ochre applied to the outer surface and just inside the neck. Triangles of graphite decorate the outer surface of the neck. The pot has been burnished but the surface is uneven.

Name: shikhuwana (zeller - museum records)

Figure XII No. 53

SAM 8944 TSHANGANA Between Manjacaze and Chibuto, Sul do Save, Mozambique. June 1963. South African Museum Expedition.

Shape: Small bowl with carination at the widest diameter, with short, straight, everted neck formed with a well-defined point of inflection, rounded rim and rounded base. H 10.7cms.

Ware: Well shaped pottery of even thickness, fairly heavy for size of the vessel. Very well fired. Light buff colour with black patches.

Decoration: no colour or burnish.

Name: shimbitana (potter - museum records)

Figure XII No. 54

SAM 8682 NKUNA Totwana, Tzaneen, Transvaal, June 1962. South African Museum Expedition.

Shape: Spherical pot with thickened rim and rounded base. H 19cms.

Ware: Well shaped, medium thick, fairly heavy ware. Well fired to a red buff with black patches.

Decoration: Graphite and ochre applied in designs outlined with narrow grooved and incised lines. Light burnish.

Figure XIII No. 55

SAM 7179 HLENGWE Sabi-Lundi, S. Rhod. 1952 B. Carp

Shape: Spherical pot with curved everted neck formed with poorly-defined point of inflection, rounded rim and rounded base. H 29cms.

Ware: Thin, well formed, light weight ware. Very well fired.

Decoration: Neatly decorated with triangular design outlined and cross-hatched with lightly grooved lines. Cross-hatched areas are filled with a white colour. Graphite and ochre applied.

Name: mbita (museum records)

Figure XIII No. 56

SAM 7191 HLENGWE Sabi-Lundi, S. Rhod. 1952. B. Carp.

Figure XIII No. 56 (continued)

Shape: Small spherical pot with curved everted neck formed with a well-defined point of inflection, rounded rim and rounded base. H 11.1cms.

Ware: Light weight, well shaped, thin walled ware. Fair firing.

Decoration: Neatly grooved triangular design patterned with cross-hatching. Hatched areas filled with white powder. Red ochre and graphite applied and burnished.

Name: mbita (museum records)

Figure XIII No. 57

SAM 7185 HLENGWE Sabi-Lundi, S. Rhod. 1952. B. Carp

Shape: Small incurved bowl with cut rim and rounded base. H 7.7cms.

Ware: Roughly formed ware. Thick walled and heavy for size of vessel.

Decoration: none

Name: mbita (museum records)

Figure XIII No. 58

SAM 7182 HLENGWE Sabi-Lundi, S. Rhod. 1952. B. Carp.

Shape: Small spherical pot with curved everted neck formed with poorly-defined point of inflection, rounded rim on tapered wall and rounded base. H 9.5cms.

Ware: Fairly light weight, well shaped ware. Very well fired.

Decoration: Neat triangular design in incised lines, patterned with cross-hatching filled with white colour. Red ochre and graphite lightly burnished.

Name: mbita (museum records)

Figure XIII No. 59

SAM 7179 HLENGWE Sabi-Lundi, S. Rhod. 1952. B. Carp.

Shape: Spherical pot with curved everted neck formed with poorly-defined point of inflection, rounded rim and rounded base. H 26.2cms.

Ware: Thin-walled, well formed ware. Light in weight. Very well fired.

Decoration: Triangular design outlined with incised lines patterned with cross-hatching. Coloured with red ochre and graphite.

Name: mbita (museum records)

Figure XIII No. 60

SAM 7181 HLENGWE Sabi-Lundi, S. Rhod. 1952. B. Carp.

Shape: Small spherical pot with curved everted neck, formed with a poorly-defined point of inflection, rounded rim on tapered wall and rounded base. H 8.25cms.

Ware: Very light thin-walled ware. Very well fired.

Decoration: Designs neatly carried out with incised lines. Cross-hatched areas filled with a white material. Red ochre mixed to a very thin consistency. Graphite band around neck.

Name: mbita (museum records)

Figure XIII No. 61

SAM 7178 HLENGWE Sabi-Lundi, S. Rhod. 1952 B. Carp.

Shape: Bowl with curved everted neck formed with poorly-defined point of inflection; rounded rim, on tapered wall, rounded base and handle. H 10 cms.

Ware: Thin light ware, roughly formed compared to other vessels in this series. Very well fired.

Decoration: Crudely executed triangular design outlined with incised lines and patterned with cross-hatching.

Use: drinking vessel (museum records)

Figure XIII No. 62

BWYO 6342 HLENGWE Christa's kraal, Sabi, S. Rhod.

Shape: Open-mouthed bowl with rounded rim on tapered wall, and rounded base. H 17cms.

Ware: Evenly formed.

Decoration: Roughly executed cross of orange ochre inside bowl.

Figure XIV No. 63

SAM 8923 TSWA Massamane, Panda, Sul do Save, Mozambique, June, 1963. South African Museum Expedition.

Shape: Spherical pot with short, curved everted neck formed with poorly-defined point of inflection, rounded rim on tapered wall and rounded base. H 17cms.

Ware: Medium heavy ware of medium thickness. Very well fired. Black patches on light buff

Figure XIV No. 63 (continued)

Ware: fired surface.

Decoration: Band of grooved triangles on buff ground. A deep red colour applied over body surface and burnished.

Use: water pot (potter - museum records)

Name: khuwana (potter - museum records)

Figure XIV No. 64

SAH 8924 TSWA Massamane, Panda, Sul do Save, Mozambique. June 1963 South African Museum Expedition.

Shape: Incurved bowl with upright neck formed with poorly-defined point of inflection, thickened rim and rounded base. H 17cms.

Ware: Unevenly formed, roughly finished ware. Very well fired. Irregularities visible in the clay. Fired a light yellow buff colour with black patches.

Use: cooking (potter - museum records)

Name: galango (potter - museum records)

Figure XIV No. 65

SAH 8925 TSWA Massamane, Panda, Sul do Save, Mozambique. June 1963 South African Museum Expedition.

Shape: Incurved bowl with compound everted neck formed with poorly-defined point of inflection, rounded rim on tapered wall and rounded base. H 19.25cms.

Ware: Heavy ware of medium thickness. Very well fired. Buff with black patches.

Decoration: Band of cross hatched grooved triangles on natural buff background.

Remainder of outer surface and upper half of the inner surface coloured a deep orange/red. Burnished.

Use: cooking (potter - museum records)

Name: galango (potter - museum records)

Figure XV No. 66

SAH 8937 TSONGA Near Morrumbene, Sul do Save, Mozambique. June 1963 South African Museum Expedition.

Shape: Large pot with carination at the widest diameter, short, straight everted neck formed with well-defined point of inflection, out rim and rounded base. H 31cms.

Figure XV No. 66 (continued)

Ware: Medium thick and heavy ware. Very well fired. Black patches from firing.

Decoration: Stamped decoration made with rounded stylus. Red/orange colour applied outside and inside in a very liquid form. Burnished surface.

Figure XV No. 67

SAN 8939 TSONGA Near Morrumbene, Sul do Save, Mozambique. June 1963 South African Museum Expedition.

Shape: Small sub-carinated bowl with short, straight everted neck formed with well-defined point of inflection, rounded rim on tapered wall and rounded base. H 8cms.

Ware: Light weight, fairly thin-walled ware. Well fired. An orange buff with black patches.

Decoration: Red colour applied unevenly over both inner and outer surface. Notched rim.

Figure XV No. 68

SAN 8938 TSONGA Near Morrumbene, Sul do Save, Mozambique. June 1963 South African Museum Expedition.

Shape: Small bowl with carination at widest diameter with short, straight everted neck formed with well-defined point of inflection, cut rim on tapered wall and rounded base. H 10.25cms.

Ware: Pottery of medium thickness and weight. Fair firing. A light buff colour with black patches.

Decoration: Red/orange colour applied on upper section of bowl both inside and outside. The entire vessel is roughly burnished.

Figure XVI No. 69

SAN 982 BASUTO Herschel District, Cape. 1905 Rev. E.J. Edney.

Shape: Pot with thickened rim and flattened base. H 28.2cms.

Ware: Well shaped, very heavy ware. Medium well fired. Smooth regular surface with vertical burnish strokes.

Decoration: Triangular design patterned with grooved lines of irregular length. Application of red ochre.

Figure XVI No. 70

WITS 40.24 BASUTO Basutoland.

Shape: Pot with carination at widest diameter, thickened rim and flattened base. H 20.5 cms.

Ware: Medium thick ware.

Decoration: Ochre coloured outer surface with black rim (not graphite). Burnished

Use: cooking pot (museum records)

Name: morotshane / pitse nkho (museum records)

Figure XVI No. 71

SAM 982 BASUTO Herschel District, Cape. 1905
Rev. E.J. Edney.

Shape: Beaker with thickened rim and flattened base. H 17.5cms.

Ware: Well shaped ware of medium thickness and weight. Smooth surface with vertical lines of burnish.

Decoration: Red ochre applied on rim. Very high burnish on outer surface.

Use: cooking (museum records) This is unlikely, it is more probable that it was used for drinking.

Figure XVI No. 72

AFRIK 4107 BASUTO

Shape: Spherical pot with tall upright neck formed with poorly-defined point of inflection, thickened rim and rounded base. H 24cms.

Ware: Very well burnished, buff ware.

Figure XVII No. 73

SAM 8563 BASUTO Malokovana, Herschel District, Cape. November 1961. South African Museum Expedition

Shape: Small sub-carinated pot with thickened rim and flattened base. H 11.6cms.

Ware: Well shaped, well finished ware of medium thickness and weight. Well fired. Natural colour of pot buff with black patches.

Decoration: Stamped design on a very smooth surface. Polished with boot black.

Use: Made for sale in Johannesburg and other large centres.

Name:

Figure XVII No. 74

SAM 8564 BASUTO Tjyindini, Herschel District, Cape.
November 1961 South African Museum Expedition.

Shape: Beaker with pedestal base and cut rim.
H 21cms.

Ware: Heavy, thick walled ware. Poorly shaped.
Very well fired.

Decoration: Application of orange ochre in a very
liquid form.

Use: drinking (seller - museum records)

Name: mokirane (seller - museum records)

Figure XVII No. 75

SAM 8638 BASUTO Basutoland. 1933 Mrs. Lazarus
Presented to museum in 1962.

Shape: Beaker on pedestal base with thickened
rim. H 19.75cms.

Ware: Pottery is thin, light, and well fired.
Poorly shaped. Fired an orange buff with
black patches.

Decoration: Very crude and rough designs in enamel
paint - black, blue, red and pink, on
lightly burnished clay surface.

Use: drinking beer (museum records)

Figure XVII No. 76

SAM 8589 BASUTO Made by Swazi. Near Butha Buthe,
Basutoland. February 1962 South African Museum
Expedition.

Shape: Beaker with pedestal base and rounded rim.
H 19cms.

Ware: Roughly made, poorly shaped ware of medium
thickness and weight. Well fired. Light
brown.

Decoration: Decorated with a band of V's in black,
green, red and deep brown enamel paint.
Slight burnish of clay surface inside and
out.

Figure XVII No. 77

SAM 8010 BASUTO Leribe, Basutoland. 1958 South
African Museum Expedition.

Shape: Beaker with pedestal foot and thickened
rim. H 17cms.

Ware: Poorly shaped ware with thick walls. Well
fired. A deep red/orange.

Figure XVII No. 77 (continued)

Decoration: Rim and foot coloured with a black material. (? clay) Slight burnish both inside and out.

Figure XVII No. 78

SAM 7440 BASUTO 1956 McFarlane.

Shape: Beaker with cut-away pedestal base and thickened rim. H 17cms.

Ware: Medium thickness and weight. Well fired. Light buff colour with smokey patches on the outer surface, inside black.

Decoration: Raised moulded designs coloured with red ochre. Stamped designs - triangular stylus. Extremely smooth, well burnished surface.

Figure XVII No. 79

SAM 8533 BASUTO Basuto Hill, Herschel District, Cape. December 1961. South African Museum Expedition.

Shape: Sub-carinated pot or beaker, with short pedestal base and rounded rim. H 17.5cms.

Ware: Thick heavy ware, poorly formed and well fired. Light buff colour.

Decoration: Designs of round stamped impressions. Red ochre applied and burnished on outer surface except on designs.

Use: drinking beer (seller - museum records)

Name: mootiwana (seller - museum records)

Figure XVII No. 80

SAM 8573 BASUTO Mhales Hoek, Basutoland.

December 1961. District Commissioner, Mhales Hoek.

Shape: Beaker with projecting base and cut rim. H 15cms.

Ware: Light weight ware of medium thickness. Very well fired. Brown buff with patches of black and bright orange streaks. Red Ochre appears to have been applied inside. Light burnishing inside and outside.

Figure XVII No. 81

SAM 8562 BASUTO Mdlokovana, Herschel District, Cape. December 1961 South African Museum Expedition

Figure XVII No. 81 (continued)

- Shape: Beaker with cut-away pedestal base and thickened rim. H 15.8cms.
- Ware: Very well fired and formed. Medium thickness and weight. Very smooth, even surface
- Decoration: Stamped design. Boot polish applied and well rubbed to give excellent finish.
- Use: Made for sale in large centres. Drinking (potter - museum records)

Figure XVII No. 82

SAM 8525 BASUTO Basuto Hill, Herschel District, Cape. December 1961 South African Museum Expedition.

- Shape: Small pot with short pedestal base and cut rim. H 14.5 cms.
- Ware: Thick, heavy ware, roughly shaped.
- Decoration: Two lightly grooved designs. Red ochre patchily applied and lightly burnished.
- Use: drinking vessel (seller - museum records)
- Name: mpot loane/ukirane (Basuto/klubi) (seller - museum records)

Figure XVII No. 83

SAM 7437 BASUTO? 1956 McFarlane.

- Shape: Sub-carinated pot with protruding base, short upright neck formed with poorly-defined point of inflection, and thickened rim. H 14.5cms.
- Ware: Well-shaped medium thick, fairly heavy ware Medium firing. Black inside.
- Decoration: Four rows impressions with triangular stylus along raised crenulate line. Very shiny black finish.

Figure XVIII No. 84

PAR B.3. BASUTO

- Shape: Sub-carinated pot with thickened rim and flattened base. H 18cms.
- Ware:
- Decoration: Band of crenulate grooved lines below mouth, giving the impression of a plait. Ochre applied and burnished.

Figure XVIII No. 85

PAR. 94.683 BASUTO Lessouto
September 1894 Holub.

Figure XVIII No. 85 (continued)

Shape: Small pot with everted neck formed with poorly-defined point of inflection, cut rim and dimple base, with two vertically pierced lugs. H 9.5cms.

Decoration: Ochre applied on outer surface, burnished.

Use: food or water (museum records)

Name: pitsa / sekhiso / nkho (museum records)

Figure XVIII No. 86

CAM. 33.820 BASUTO Herschel District, Cape.

Shape: Sub-carinated pot with thickened rim and projecting base. H 15cms.

Decoration: Band of stamped triangular impressions along raised crenulate section of vessel. Outer surface said to be coloured with burnished graphite.

Figure XIX No. 82

SAM 8522 BAPOKENG Basuto Hill, Herschel District, Cape. December 1961 South African Museum Expedition

Shape: Pot with upright neck formed with poorly-defined point of inflection, cut rim and flattened base. H 23.5cms.

Ware: Thick walled, very heavy ware. Very poorly shaped.

Decoration: none - smeared with scum of beer both inside and outside.

Name: nkhoana (Basuto) inggazana (Xhosa) (seller - museum records)

Figure XIX No. 88

SAM 1796 (1) BASUTO Butha Buthe, Basutoland. 1914 H. Ashton.

Shape: Small bag-shaped pot with rounded rim and rounded base. H 14.5cms.

Ware: Very roughly finished, heavy pottery. Blackened by use. Medium firing.

Figure XIX No. 89

SAM 8549 BAPOKENG Mafeteng, Basutoland 1959 Bought Rev. P. Ellenberger November 1961 South African Museum Expedition.

Figure XIX No. 89 (continued)

- Shape: Pot with sub-carination at widest diameter, thickened rim and flattened base. H 18.3cms.
- Ware: Heavy ware of medium thickness. Well fired Well formed with very smooth outer surface and roughly finished inner surface.
- Decoration: Rim coloured blue. Slight burnish on outer surface.

Figure XIX No. 90

SAM 8571 FOKENG Basuto Hill, Herschel District, Cape. November 1961 South African Museum Expedition.

- Shape: Barrel-shaped pot with cut rim and flattened base. H 20cms.
- Ware: Very heavy thick ware. Poorly formed.
- Decoration: Black with very slight burnish.
- Name: nkhoana (potter - museum records)

Figure XIX No. 91

SAM 8453 BASUTO Mount Ayliff, Transkei. April 1961 South African Museum Expedition.

- Shape: Barrel-shaped pot with slightly thickened rim and flattened base. H 19.8cms.
- Ware: Fairly evenly formed ware of medium thickness. Very well fired.
- Decoration: Incised triangles patterned with hatching alternating with graphite coloured triangles. Lightly burnished outside and well smoothed inside.
- Use: Small beer pot. (potter - museum records)
- Name: sepotjswana (potter - museum records)

Figure XIX No. 92

UCT B50 ? BASUTO

- Shape: Sub-carinated bowl with thickened rim and flattened base. H 13.5cms.
- Ware: Evenly formed vessel of medium thickness and weight. Well smoothed inside and out. Fired orange.
- Decoration: Rim reddened with applied ochre. Outer surface burnished.

Figure XX No. 93

Figure XX No. 93

SAM 8590 BAKWENA Tumane Matela's village, Butha Buthe, Basutoland. February 1962. South African Museum Expedition.

Shape: Large very evenly shaped pot with everted neck formed with poorly-defined point of inflection, out rim and flattened base.
H 37cms.

Ware: Even formed, light weight ware. Very well fired. Orange colour with black patches.

Decoration: Rim painted black.

Use: Storing water (potter - museum records)

Name: nkhe (potter - museum records)

Figure XX No. 94

SAM 8605 HLAKWANA Maputhseng, Mhales Hoek, Basutoland. February 1962. South African Museum Expedition.

Shape: Pot with upright neck formed with poorly-defined point of inflection, thickened rim and rounded base. H 20cms.

Ware: Thick, heavy ware. Fairly well fired. Pale buff with black patches.

Use: (1) being used for storing dry foodstuffs when bought.

Use: (11) storing water or making porridge (potter - museum records)

Name: mokhakhe (potter - museum records)

Figure XX No. 95

SAM 8586 BAFOKENG Hatlebere, Near Mazenod Mission Maseru, Basutoland. February 1962 South African Museum Expedition.

Shape: Barrel-shaped pot with upright neck formed with poorly-defined point of inflection, thickened rim and dimple base. H 28.5cms.

Ware: Thin walled, unevenly shaped vessel of medium weight. Well fired. Cross-section through biscuit shows black clay in the centre. Fired to a buff orange with black patches on both inner and outer surfaces.

Name: nkhe (potter - museum records)

Figure XX No. 96

SAM 8011 BASUTO Leribe, Basutoland. 1958. South African Museum Expedition.

Shape: Large sub-carinated pot with upright neck

Figure XX No. 96 (continued)

- Shape: formed with poorly-defined point of inflection thickened rim and flattened base. H 29.5cms.
- Ware: Well formed heavy ware. Walls of medium thickness at rim but increasing in thickness towards base. Very well fired. Bright orange red with black patches. Surface of vessel covered with fine network of shallow cracks.
- Decoration: Rim coloured with black paint. Outer surface lightly burnished.

Figure XX No. 97

- SAM 8560 FOKENG Basuto Hill, Herschel District, Cape. November 1961. South African Museum Expedition.
- Shape: Inverted bag-shaped pot with upright neck formed with poorly-defined point of inflection, cut rim and flattened base. H 28cms.
- Ware: Heavy, unevenly made ware. Thick walled. Very well fired. Orangey buff colour with black patches.
- Decoration: very light burnish on outer surface.
- Name: nkhoana (seller - museum records)

Figure XX No. 98

- SAM 7072 BASUTO Basutoland 1949 V.G. Sheddick
- Shape: Large inverted bag-shaped pot with tall, curved, everted neck formed with poorly-defined point of inflection, rounded rim and flattened base. H 34cms.
- Ware: Fairly well shaped, thick, heavy ware. Well fired to an orange colour with black patches.
- Decoration: Lightly burnished inside neck.

Figure XX No. 99

- SAM 8012 BASUTO Leribe, Basutoland. 1958 South African Museum Expedition.
- Shape: Bag-shaped pot with upright neck formed with poorly-defined point of inflection, thickened rim and rounded base. H 22cms.
- Ware: Unevenly formed, heavy pottery. Vessel walls decrease in width from base to mouth. Very well fired. Buff with patches of orange and black.
- Decoration: Rim painted black. Lightly burnished.

Figure XXI No. 100

SAM 8521 BAFOKENG Basuto Hill, Herschel District Cape. November 1961 South African Museum Expedition.

Shape: Large open-mouthed bowl with out rim and flattened base. H 27cms.

Ware: Thick, heavy ware. Fairly well fired. Light orange with black patches.

Decoration: None. Smearred with the scum off the beer.

Figure XXI No. 101

SAM 8587 BAFOKENG Hatlebere, Near Mazenod Mission, Maseru, Basutoland. February 1962 South African Museum Expedition.

Shape: Small pot with short upright neck formed with poorly-defined point of inflection, thickened rim and flattened base. H 17.5cms.

Ware: Evenly shaped vessel of fairly heavy, medium thick ware. Very well fired to a bright orange with patches of buff and smokey black.

Decoration: Rim coloured blue. Slight burnish.

Name: nkhoana (seller - museum records)

Figure XXI No. 102

SAM 8524 BASUTO Near Telle Bridge, Herschel District, Cape. November 1961 South African Museum Expedition.

Shape: Widemouthed bag-shaped vessel with thickened rim and flattened base. H 27cms.

Ware: Very thick heavy ware, very roughly finished. Very well fired. Orange colour with black patches. Smooth unburnished surface.

Name: nkho (potter - museum records)

Figure XXI No. 103

SAM 8536 BASUTO Majuba's Nek, Herschel District, Cape. November 1961. South African Museum Expedition.

Shape: Widemouthed sub-carinated pot with upright neck formed with poorly-defined point of inflection, out rim and flattened base. H 28.24cms.

Figure XXI No. 103 (continued)

Ware: Thick, heavy ware. Symmetrical shape though roughly finished. Medium firing.

Decoration: None. Smearred with beerscum.

Name: ingayi (seller - museum records)

Figure XXI No. 104

SAM 8449 BASUTO Pontseng, Matatiele.

April 1961 South African Museum Expedition.

Shape: Inverted bag-shaped pot with upright neck formed with poorly-defined point of inflection, rounded rim and flattened base. H 31.2 cms.

Ware: Fairly thick ware. Very well fired. Well burnished. A rich, shiney brown colour from use.

Use: beerpot (seller - museum records)

Name: lefitswana (seller - museum records)

Figure XXI No. 105

SAM 8599 KWENA HaPhalwane, near Nazareth Mission, Maseru, Basutoland. February 1962 South African Museum Expedition.

Shape: Sub-carinated pot with upright neck formed with poorly-defined point of inflection, thickened rim and flattened base. H 29.5 cms.

Ware: Heavy ware of medium thickness. Well shaped and of medium weight. Very well shaped and of medium weight. Well fired. An orange colour with patches of buff and black.

Decoration: Lightly burnished.

Name: nkho (seller - museum records)

Figure XXI No. 106

SAM 596 BASUTO Maseru, Basutoland.

Shape: Wide-mouthed, sub-carinated bowl with curved, everted neck, formed with poorly-defined point of inflection, cut rim and flattened base. H 20 cms.

Ware: Very well shaped and finished ware. Fired a light orange.

Decoration: Slightly projecting collar around neck coloured with red ochre and burnished.

Use: for beer or water (museum records)

Name: morifi (museum records)

Figure XXII No. 107

BWYO 2048 MANGWATO Serowe, Bechuanaland. N. Jones, to whom it was given by the wife of Chief Khama.

Shape: Sub-spherical pot with short, curved everted neck formed with poorly-defined point of inflection, rounded rim and rounded base. H 25.5 cms.

Decoration: Incised design. Graphite and ochre applied and burnished.

Figure XXII No. 108

SAM 8757 MANGWATO Ratholo, Bechuanaland. September 1962 South African Museum Expedition.

Shape: Very large pot with short, curved neck, everted, formed with poorly-defined point of inflection, rounded rim and rounded base. H 41 cms.

Ware: Very heavy, thick ware. Well formed. Well fired. Buff with smokey patches. Smoothed inside and outside.

Decoration: Very lightly burnished. Smears with beer-scum inside.

Name: pitso (seller- museum records)

Figure XXII No. 109

SAM 8750 MAKALANGA Serowe, Bechuanaland September 1962. South African Museum Expedition.

Shape: Large sub-spherical pot with short, curved everted neck formed with well-defined point of inflection, rounded rim on tapered wall and rounded base. H 38.75 cms.

Ware: Well shaped vessel of medium thickness and medium weight. Poor firing. Smokey patches both inside and outside.

Decoration: Red ochre applied and burnished both inside and outside.

Figure XXIII No. 110

SAM 8732 NGWAKETSE Moswaana Cattle Post, Kanye Bechuanaland. September 1962 South African Museum Expedition.

Shape: Pot with curved, everted neck formed with well-defined point of inflection, cut rim on tapered wall and flattened base. H 18.3 cms.

Figure XXIII No. 110 (continued)

Ware: Very heavy thick-walled ware. Well fired. Buff with smokey patches.

Decoration: Grooved orenulate bands and round stamped impressions. Application of graphite and red ochre. Well burnished. Below the area of burnished ochre the surface is shiny due to an application.

Figure XXIII No. 111

SAM 1168 NGWAKEPSE Kanye, Bechuanaland Protectorate. 1908 J. Drury.

Shape: Sub-spherical pot with everted neck formed with well-defined point of inflection, rounded rim on tapered wall and rounded base. H 19cms.

Ware: Fairly heavy ware. Very evenly shaped.

Decoration: Red ochre applied inside neck and three-quarters of the way down the outside of the vessel. Burnished.

Figure XXIII No. 112

UCT 38.48 NGWAKETSE Kanye, Bechuanaland Protectorate. Schapera.

Shape: Sub-spherical pot with short, straight everted neck formed with well-defined point of inflection, rounded rim on tapered wall and rounded base. H 26cms.

Ware: Well shaped ware, heavy, fairly thick walled. Medium firing.

Decoration: Band of triangles outlined with lightly incised lines and coloured blue (? carbon/ink) Red ochre applied and well burnished.

Use: beerpot (museum records)

Figure XXIV No. 113

SAM 8731 NGWAKETSE Lobatsi Station, Bechuanaland Protectorate. September 1962 (made at Kanye) South African Museum Expedition.

Shape: Pot with straight everted neck formed with well-defined point of inflection, cut rim and rounded base. H 30cms.

Ware: Very heavy ware of medium thickness. Well fired. Well shaped, roughly finished. Small stones visible in the clay.

Figure XIV No. 113 (continued)

Decoration: Roughly executed band of ovals. Application of ochre and manganese. Burnished. below ochre shiny surface due to an application.

Figure XIV No. 114

UCT 38.49 NOWAKETSE I. Schapera

Shape: Pot with short, straight everted neck formed with well-defined point of inflection, rounded rim and rounded base. H 14cms.

Ware: Medium thick. Poor firing. Outer surface very smooth, inner surface very rough.

Decoration: Red ochre applied and burnished inside neck and on outer surface. Vessel burnished except for base.

Figure XIV No. 115

SAM 2372 TSWANA Dr. Way

Shape: Widemouthed incurved bowl with everted neck formed with well-defined point of inflection, rounded rim and rounded base. H 11.5cms.

Ware: Uneven ware of medium thickness. Medium firing.

Decoration: Stamped band and triangle design. Applied graphite and red ochre. Well burnished.

Use: Cooking (museum records)

Name: pitsa (museum records)

Figure XIV No. 116

SAM 1168 NOWAKETSE Kanye, Bechuanaland Protectorate. 1908 J. Drury.

Shape: Spherical pot with straight everted neck formed with well-defined point of inflection, out rim on tapered wall and rounded base. H 17cms.

Ware: Well formed ware. Thick base decreasing towards mouth.

Decoration: Red ochre applied inside neck and three-quarters down outer surface. Burnished

Figure XIV No. 117

SAM 8728 HURUTHSE Zeerust, Transvaal. September 1962 South African Museum Expedition.

Figure XXIV No. 117 (continued)

- Shape: Spherical pot with short, straight everted neck formed with well-defined point of inflection, cut rim on tapered wall and rounded base. H 6.9cms.
- Ware: Very heavy pottery. Well shaped with thick walls. Very well fired. Small irregularities in fired clay (asbestos)
- Decoration: Poorly executed decoration. Incised bands and geometrical shapes patterned with stamped impressions made with a square stylus. Application of a black material and red ochre.

Figure XXV No. 118

- Pitt R. 489. Bachapin (Bathlapin) Litakun. Bechuanaland Protectorate. Burchell.
- Shape: Small widemouthed, incurved bowl with upright neck formed with poorly-defined point of inflection, flattened rim and rounded base. H 12.5cms.
- Decoration: Red ochre applied and burnished on outer surface. Thong bound round neck for strengthening and a second thong used as a handle.

Figure XXV No. 119

- SAM 8734 KXALAXADI Near Molepolole, Bechuanaland Protectorate. September 1962. South African Museum Expedition.
- Shape: Spherical pot with short, straight everted neck formed with well-defined point of inflection, rounded rim on tapered walls and rounded base. H 16.5cms.
- Ware: Well shaped vessel of medium thickness. Fairly heavy ware. Very well fired. Natural fired colour buff with black patches.
- Decoration: Very neatly incised design coloured with coloured enamel paints - yellow, white, black and red. Red ochre applied inside neck and on body of the vessel outside. Very well burnished.
- Name: sejana (potter - museum records)

Figure XXV No. 120

- UCT 35.191 MALETE Ramoutsa, Bechuanaland Protectorate. July 1935 Schapera and Goodwin.

Figure XXV No. 120 (continued)

Shape: Sub-carinated pot with everted neck formed with well-defined point of inflection, rounded rim on tapered wall and slightly flattened base. H 22.5cms.

Ware: Well shaped ware of medium thickness. Fairly well fired.

Decoration: Band of white colour applied in a crenulate line around sub-carination outlined with black (? clay) Red ochre applied inside neck and over entire outer surface.

Name: sejana (museum records)

Figure XXV No. 121

SAM 5532 MALETE/TLOKWA Ramoutsa, Bechuanaland Protectorate. September 1935 A.J.H. Goodwin.

Shape: Sub-carinated pot with straight everted neck formed with well-defined point of inflection, rounded rim on tapered wall and flattened base. H 26.8cms.

Ware: Very well shaped ware of medium thickness and weight. Well fired.

Decoration: Red oxide very well burnished applied over entire outer surface and inside neck.

Figure XXVI No. 122

SAM 967 KALANGA Serowe, Bechuanaland. 1907 Blackbeard Brothers.

Shape: Spherical pot with short, curved everted neck formed with well-defined point of inflection, rounded rim and rounded base. H 29.3cms.

Ware: Well shaped pottery of medium thickness. Light in weight. Well fired. Natural colour of fired clay deep orange.

Decoration: Band of finely incised triangles coloured with burnished graphite. Band of graphite around mouth. Ochre applied and burnished.

Figure XXVI No. 123

SAM 8751 KALANGA Serowe, Bechuanaland Protectorate. September 1962 South African Museum Expedition.

Shape: Small spherical pot with short, curved everted neck formed with poorly defined point of inflection, rounded rim and rounded base. H 16cms.

Figure XXVI No. 123 (continued)

Ware: Well formed, thick, heavy ware. Very well fired.

Decoration: Two zig-zag bands of graphite, lightly burnished on burnished ochre background.

Figure XXVI No. 124

SAH 8735 KXALAXADI Molepolole, Bechuanaland Protectorate. September 1962 South African Museum Expedition.

Shape: Sub-spherical pot with short, straight everted neck formed with well-defined point of inflection rounded rim on tapered wall and rounded base. H 23.5cms.

Ware: Well formed, thick, heavy ware. Very well fired. Deep orange colour.

Decoration: Neatly incised design coloured with enamel paints. Red ochre applied and well burnished.

Figure XXVII No. 125

UCT 35.28 MANOWATO I. Schapera

Shape: Inverted bag-shaped pot with short everted (compound) neck formed with poorly-defined point of inflection, rounded rim and rounded base. H 28cms.

Ware: Very light, thin walled ware. Well fired. Deep orange.

Decoration: Poorly executed. Signs of incised lines outlining black design around upper section of the vessel.

Use: carrying water (museum records)

Figure XXVII No. 126

UCT 35.25 MANOWATO I. Schapera

Shape: Pot with carination at widest diameter, with short, everted neck formed with well-defined point of inflection, rounded rim and rounded base. H 28cms.

Ware: Very well formed, thin walled, light weight ware. Very well fired. Dark orange.

Decoration: Poorly executed. Black designs very lightly outlined with incised lines. Ochre applied and burnished.

Use: carrying water (museum records)

Figure XXVII No. 127

UCT 36.8 MANGWATO I. Schapera

Shape: Shallow incurved bowl with thickened rim and flattened base. H 7.5 cms.

Ware: Very well shaped pot of medium thickness and weight. Smooth, matt finish. Gritty clay. Brown with smokey patches.

Decoration: Neat honeycomb pattern stamped along rim and in two places below it.

Figure XXVII No. 128

COP. G. 6523 MANGWATO Serowe, Bechuanaland.

Registered after 1961.

Shape: Sub-spherical pot with inward-sloping neck formed with poorly-defined point of inflection, cut rim and rounded base with lid (No. 128a) H 17 cms.

Ware: Unevenly formed, poorly made ware.

Decoration: Raised ribs at irregular intervals around the circumference of the vessel. Red ochre burnished.

Figure XXVIII No. 129

SAM 1968 THLAPING Bechuanaland ? 1906 G. Hunter

Shape: Spherical pot with short, everted neck formed with well-defined point of inflection, cut rim on tapered wall and rounded base. H 25 cms.

Ware: Vessel of medium thickness and weight. Fairly well fired.

Decoration: Design outlined with grooved lines. Stamped impressions made with very sharp stylus on body and on out surface of rim. The four outer grooved lines of the design are filled with a white powder. Graphite and red ochre burnished.

Use: serving beer - ladled into drinking vessels from this (museum records)

Name: nkgwana (museum records)

Figure XXVIII No. 130

UCT 35.128 MANGWATO I. Schapera.

Shape: Narrow-mouthed sub-spherical pot with rounded rim and rounded base. H 20.5cms.

Ware: Thick heavy ware. Well shaped. Poor firing.

Decoration: Red ochre applied and burnished with vertical strokes.

Figure XXVIII No. 131

SAM 653 THLAPING (Toto's people) Langberg,
Bechuanaland. 1916 Mrs. Hunter

Shape: Pot with short, straight, everted neck
formed with well-defined point of
inflection, out rim and rounded base.
H 27 cms.

Ware: Very thick heavy ware. Poor firing.
O range buff.

Decoration: Red ochre applied within very roughly
incised designs and lightly burnished.

Use: beer (museum records)

Name: nkgwana (museum records)

Figure XXIX No. 132

BWYO 2018 TSWANA Maun, Bechuanaland.

Shape: Spherical pot with tall, straight, upright
neck formed with well-defined point of inf-
lection, out rim and rounded base. H 31cms.

Decoration: Red ochre triangular design on buff
ground.

Figure XXIX No. 133

BWYO 2017 TSWANA Maun, Bechuanaland.

Shape: Spherical pot with tall, curved everted neck
formed with well-defined point of inflection,
out rim and small projecting base. H 29.5cms.

Decoration: Red ochre triangular design on buff
ground.

Figure XXX No. 134

SAM 5055 TSWANA Ngami, Bechuanaland 1927. Ross-Frames.

Shape: Pot with carination at widest diameter,
tall, curved, everted neck formed with well-
defined point of inflection, out rim and
hollow-based pedestal base surrounding pointed
base. H 31.6 cms.

Ware: Well shaped ware of medium thickness and
weight. Well fired. Orange buff.

Decoration: All over design of incised triangles
and bands coloured with red ochre and
lightly burnished.

Figure XXX No. 135

SAM 966 TSWANA Bechuanaland. 1907 Blackbeard
Brothers.

Figure XXX No. 135 (continued)

- Shape: Sub-spherical pot with everted neck formed with poorly-defined point of inflection, rounded rim on tapered wall and rounded base. H 27.5cms.
- Ware: Well shaped, thin walled, light weight pottery. Very well fired. Red brown.
- Decoration: Band of incised rectangles coloured with burnished graphite on background of burnished red ochre. Graphite applied both on inner and outer neck surface.
- Name: seyana (museum records)

Figure XXX No. 136

- SAN 4170 ? TSWANA Cave at Marulakop, Zeerust, Transvaal. 1923 George Reid.
- Shape: Small incurved bowl with short everted neck formed with poorly-defined point of inflection, out rim and rounded base. H 12cms.
- Ware: Medium thick and heavy ware. Neatly shaped. Poor firing. Worn by use and weathering.
- Decoration: Three lines of stamped rectangular impressions around upper section of vessel. Red ochre over three-quarters of outer surface, lightly burnished - now very poor.

Figure XXXI No. 137

- AFRIK 39/212 Maun, Ngamiland.
- Shape: Inverted bag-shaped pot with everted neck formed with poorly-defined point of inflection, out rim and rounded base. H 21.5cms.
- Decoration: Red ochre design on buff background, outlined with incised lines.

Figure XXXII No. 138

- SAN 8748 KGATLA Mochudi, Bechuanaland Protectorate September 1962 South African Museum Expedition.
- Shape: Sub-carinated bowl with rounded rim thickened by decorative ridge, and flattened base. H 15.5cms.
- Ware: Well shaped thick walled, heavy ware. Well fired.
- Decoration: All over pattern of raised moulded decorative knobs and ridges. Red/orange ochre applied inside and outside. Well burnished

Figure XXXII No. 139

UCT 61/35 KGATLA I. Schapera.

Shape: Sub-carinated bowl with short, straight everted neck formed with well-defined point of inflection, rounded rim and flattened base. H 13cms.

Ware: Well shaped, thick walled, heavy ware. Poor firing.

Decoration: Black design (? clay) on red ochre background. Well burnished.

Figure XXXII No. 140

UCT 32.28 KGATLA Mochudi, Bechuanaland Protectorate. I. Schapera.

Shape: Sub-carinated bowl with short, straight everted neck formed with well-defined point of inflection, rounded rim on tapered wall and rounded base. H 18cms.

Ware: Medium thick pottery, fairly heavy in weight. Well shaped. Poor firing. Section of wall shows gritty clay.

Decoration: Red/orange ochre finish. Good burnish.

Figure XXXII No. 141

SAM 8796 KWENA BA MOGOPA Bethanie, Rustenburg, Transvaal. 1936. Government Ethnologist. Presented to museum September 1962.

Shape: Small bowl with carination at widest diameter, straight everted neck formed with well-defined point of inflection, rounded rim and flattened base. H 11.8cms.

Ware: Very well shaped ware of medium thickness. Heavy ware.

Decoration: Applied brown colour. Very well burnished outer surface.

Name: nkgwana (museum records)

Figure XXXII No. 142

UCT 32.29 KGATLA Mochudi, Bechuanaland Protectorate I. Schapera.

Shape: Deep incurved bowl with double sub-carination, short everted neck formed with well-defined point of inflection, rounded rim and flattened base. H 22.2oms.

Ware: Thick, heavy ware. Well formed. Orange buff.

Decoration: Band of black material in trough between carinations. Burnished red ochre finish.

Figure XXXII No. 143

UCT 61/E36 KGATLA I. Schapera

Shape: Shallow open mouthed bowl with flattened thickened rim and projecting base.
H 12.2cms.

Ware: Thick walled, heavy ware. Well shaped. Fairly well fired.

Decoration: Design in black material (? clay) on red ochre burnished background.

Figure XXXIII No. 144

UCT 35/197 TLOKWA Gaborones, Bechuanaland Protectorate. I. Schapera and A.J.H. Goodwin.

Shape: Large sub-carinated pot with short everted neck formed with well-defined point of inflection, rounded rim on tapered wall and flattened base. H 37.3cms.

Ware: Thick, heavy ware. Well shaped. Orange with black patches. Gritty clay. Brown inside cross-section of wall. Well fired.

Decoration: Decorative band in black (? clay) on burnished red ochre background. Thong around neck.

Figure XXXIV No. 145

WITS 32/E9 KGATLA Mochudi, Bechuanaland Protectorate. I. Schapera.

Shape: Pot with carination at widest diameter, which coincides with base of neck, everted neck, rounded rim and flattened base. H 28.3cms.

Decoration: Decorative band in black (? clay) on red ochre background.

Figure XXXV No. 146

SAM 6577 SOTHO Boomplaats, Lydenburg, Transvaal. 1946. Per Government Ethnologist.

Shape: Large inverted bag-shaped pot with curved everted neck formed with poorly defined point of inflection, rounded rim and rounded base. H 30.6cms.

Ware: Well shaped ware of medium thickness. Heavy. Well fired to a brown buff colour.

Decoration: Crenulate band and geometric designs outlined with wide grooved lines. Stamped impressions carried out with point of stylus pressed into clay at an angle to give oval impression deeper at one end than the other

Figure XXXV No. 146 (continued)

Name: moeta (Government Ethnologist- museum records)

Figure XXXV No. 147

SAM 6579 SOTHO Boomplaats, Lydenburg, Transvaal
1946. Per Government Ethnologist.

Shape: Inverted bag-shaped pot with curved everted neck formed with poorly-defined point of inflection, rounded rim and rounded base.
H 21.4 cms.

Ware: as No. 146

Decoration: Designs outlined with wide grooved lines. Coloured with graphite and red ochre. Very well burnished.

Name: selsana (Government Ethnologist - museum records)

Figure XXXV No. 148

SAM 6589 SOTHO Boomplaats, Lydenburg, Transvaal.
1946 Per Government Ethnologist.

Shape: Small incurved bowl with rounded rim and flattened base. H 9 cms.

Ware: as No. 146

Decoration: Design outlined with grooved lines, row of stamped impressions made with small sharp stylus.

Name: letwanyana (Government Ethnologist - museum records)

Figure XXXV No. 149

SAM 4991 SOTHO Pietersburg, Northern Transvaal.

Shape: Tall bag-shaped beaker with thickened rim and short pedestal base. H 18 cms.

Ware: Thin light weight ware. Well shaped and fired. Fired a light buff. Section of wall shows a black centre to biscuit.

Decoration: Band and triangle design outlined with very deeply incised lines which appear to have been done after firing. Red ochre coloured triangles. Horizontal band coloured brown.

Figure XXXV No. 150

SAM 4994 NORTHERN SOTHO (undifferentiated) Pietersburg
Northern Transvaal. Ross Frames.

Figure XXXV No. 150 (continued)

- Shape: Wide-mouthed bowl with sub-carination at the widest diameter, which coincides with base of neck, upright neck, cut rim and rounded base with small hole at the apex of the base, and four legs. H 15.3 cms.
- Ware: Well shaped ware of medium thickness and light weight. Well fired. Flakes of muscovite mica in clay.
- Decoration: No longer very clear since pot is covered with whitish deposit. Grooved bands filled with graphite and red ochre, one band stamped impressions and band of triangles coloured with burnished graphite just visible.

Figure XXXV No. 151

- UCT 61/E47 ? PEDI Transvaal.
- Shape: Spherical bowl with short, curved everted neck formed with poorly-defined point of inflection, thickened rim and straight projecting base. H 12 cms.
- Ware: Heavy, poorly formed ware.
- Decoration: Rectangular stamped impressions forming band and triangle design, coloured with burnished graphite. Red ochre burnished over rest of outer surface.

Figure XXXVI No. 152

- SAM 6576 SOTHO Boomplaats, Lydenburg, Northern Transvaal. 1946 Per Government Ethnologist.
- Shape: Large narrow-mouthed bag-shaped pot with rounded rim and slightly flattened base. H 34.7 cms.
- Ware: as No. 146
- Decoration: Grooved band and triangle design. Coloured with well-burnished graphite and red ochre.
- Name: lexopa (Government Ethnologist - museum records)

Figure XXXVI No. 153

- SAM 6587 SOTHO Boomplaats, Lydenburg, Northern Transvaal. 1946 per Government Ethnologist.
- Shape: Incurved bowl with rounded rim and rounded base. H 17.3 cms.
- Ware: as No. 146

Figure XXXVII No. 157

SAM 6580 SOTHO Boomplaats, Lydenburg, Transvaal
1946 Per Government Ethnologist.

Shape: Inverted bag-shaped pot with curved everted neck, formed with poorly defined point of inflection, rounded rim and slightly flattened base. H 19.5cms.

Ware: as No. 146

Decoration: Grooved design. Stamped impressions made with sharp stylus pressed unevenly into clay to give oval, deeper at one end than the other. Graphite and red ochre burnished.

Name: sedibelwana (Government Ethnologist -
Museum records)

Figure XXXVII No. 158

SAM 4993 KWENA/MOLETSE Chief Moloto, Pietersburg,
Northern Transvaal. Ross Frames.

Shape: Inverted bag-shaped pot with upright neck, thickened rim and rounded base. H 11.5cms.

Ware: Very thick walled ware. Medium firing.
Brownish colour.

Decoration: Grooved bands and arcs. Stamped band below rim filled with white colour. Graphite and red ochre very lightly burnished.

Use: beerpot - (museum records)

Figure XXXVIII No. 159

B.M. 1933-1-93 PEDI Jane Furze Hospital
Sekhukhunieland, Transvaal.

Shape: Incurved bowl with cut rim and rounded base
H 17.3cms.

Ware: Well shaped.

Decoration: Incised design of triangles alternately cross-hatched and coloured with graphite. Red ochre burnished. Hatched areas filled with white material.

Figure XXXVIII No. 160

AFRIK 59/2334A PEDI Sekhukhunieland, Transvaal.

Shape: Pot with carination at the widest diameter, thickened rim and flattened base. H 21cms.

Decoration: Grooved bands and triangles. Incised cross-hatching. Coloured graphite and red ochre and burnished.

Use: carrying water (museum records)

Figure XXXVIII No. 161

AFRIK 581649 PEDI Pietersburg, Transvaal.

Shape: Spherical pot with rounded rim and rounded base. H 22 cms.

Decoration: Decorated with triangles and bands outlined with incised lines and coloured alternately with ochre and graphite.

Figure XXXVIII No. 162

B.M. 1933 1-9-5 Jane Furze Hospital, Sekhukhune-land, Transvaal. PEDI

Shape: Barrel-shaped pot with out rim and flattened base. H 17.9 cms.

Decoration: Designs outlined with incised lines coloured with graphite and red ochre. Very well burnished.

Figure XXXIX No. 163

SAM 6036 SWAZI, made in PEDI tradition, Sekhukhune-land, Transvaal. 1939 Per D.C. Sekhukhune-land.

Shape: Spherical pot with short, upright neck, formed with poorly-defined point of inflection, rounded base and rounded rim. H 21.3cms.

Ware: Very heavy ware with walls of medium thickness Very well fired. Brown buff.

Decoration: Grooved band and triangles pattern. Stamped band of oval impressions around neck. Graphite and ochre burnished.

Name: letsuoa (museum records)

Figure XXXIX No. 164

SAM 6138 SWAZI, made in PEDI tradition, Sekhukhune-land, Transvaal. 1939 Per D.C. Sekhukhune-land.

Shape: Wide-mouthed incurved bowl with short, everted neck formed with poorly-defined point of inflection, cut rim and rounded base. H 15.9 cms.

Ware: Well shaped ware of medium thickness and weight.

Decoration: Crenulate band outlined with three grooved lines coloured with burnished graphite. Band of stamped impressions. Red ochre burnished.

Use: beer container (Venter in lit Sept. 1964)

Name: murusoana (museum records)

Figure XXXIX No. 165

SAM 8680 SWAZI, made in PEDI tradition, Lulu Mountains, Sekhukhune-land. Sept. 1962. South African Museum Expedition.

Figure XXXIX No. 165 (continued)

- Shape: Pot with short, curved everted neck formed with poorly-defined point of inflection, rounded rim on tapered wall and rounded base. H 17.8 cms.
- Ware: Well shaped ware of medium thickness and weight. Fired buff.
- Decoration: Stamped oval impressions and grooved crenulate design. Applied red ochre and graphite. Burnished.
- Use: container for water (Venter in lit Sept. 1964)
- Name: moetana ea metsi (ditto)

Figure XXXIX No. 166

- SAM 4993 KWENA/MOLETSE. Chief Moleto's people Pietersburg, Transvaal. Ross Frames.
- Shape: Spherical pot with upright neck formed with well-defined point of inflection, rounded rim and rounded base. H 22 cms.
- Ware: Heavy weight, fairly thick walled ware. Fired brown buff.
- Decoration: Band of stamped decoration around neck. Crenulate band of stamped impressions. Application graphite and ochre, burnished.

Figure XXXX No. 167

- SAM 8826 LOBEDU Medingen, Pietersburg, Transvaal 1936 Government Ethnologist. Presented to museum September 1962.
- Shape: Large spherical pot with short upright neck formed with well-defined point of inflection, rounded rim and rounded base. H 26 cms.
- Ware: Medium thick walled pottery. Fairly heavy. Beautifully shaped and finished.
- Decoration: Designs outlined with rectangular stamped impressions. Outlines whitened. Red ochre and graphite, very well burnished.

Figure XXXX No. 168

- SAM 8796 LOBEDU Medingen, Pietersburg, Transvaal. 1936. Government Ethnologist, Presented to museum September 1962.
- Shape: Sub-spherical pot with very short upright neck formed with well-defined point of inflection, thickened rim and flattened base. H 18 cms.
- Ware: Beautifully shaped and decorated ware of medium thickness. Heavy. Brown-orange-buff.

Figure XXXX No. 168 (continued)

Decoration: Decorated with designs outlined with rectangular stamped impressions. These lines are whitened and the designs themselves coloured either with graphite or ochre and very well burnished.

Figure XXXX No. 169

SAM 8799 LOBEDU Medingen, Pietersburg, Transvaal 1936. Government Ethnologist, Presented September 1962.

Shape: Pot with carination at the widest diameter, short upright neck formed with well-defined point of inflection, rounded rim and rounded base. H 14cms.

Ware: Beautifully formed and decorated ware of medium thickness and weight. Well fired. Brown orange buff.

Decoration: Designs outlined with stamped rectangular impressions. Graphite, red ochre and a white material applied. Well burnished.

Figure XXXX No. 170

SAM 8800 LOBEDU Medingen, Pietersburg, Transvaal 1936. Government Ethnologist. Presented September 1962

Shape: Incurved bowl with thickened rim and flattened base. H 12.8cms. (sub-carinated)

Ware: Beautifully made, medium thick, heavy ware. Clear deep orange red. Fairly well fired.

Decoration: Neatly decorated with stamped impressions. Red ochre, graphite and white material applied. Lightly burnished.

Figure XXXXI No. 171

UCT 38.83 LOBEDU Northern Transvaal Lowveld.

Krige.

SHAPE: Pot with thickened rim and rounded base. H 20cms.

Ware: Beautifully shaped ware with walls of medium thickness. Light in weight. Medium firing. Mottled orange, brown and black. Burnished surface.

Figure XXXI No. 171 (continued)

Decoration: Decorated with design outlined with stamped lines, coloured with graphite and ochre and well burnished. White material rubbed into stamped impressions. Star design on the base of vessel is said to be modern (No. 171a)

Use: for serving beer (krage - museum records)

Name: ledzomelo, letjomele or thukwana (krage - museum records)

Figure XXXI No. 172

SAM 8684 LOBEDU Modjadji's place, Duiwelskloof, Transvaal. September 1962 South African Museum Expedition.

Shape: Small spherical pot with thickened rim and rounded base. H 8cms.

Ware: Well shaped ware of medium thickness. Heavy for size of vessel. Well fired. Brown-orange buff with smokey patches.

Decoration: Grooved lines. Coloured with graphite and red ochre. Lightly burnished.

Figure XXXI No. 173

UCT 38.87 LOBEDU Northern Transvaal Lowveld.

Krige.

Shape: Incurved bowl with thickened rim and small pedestal base. H 12cms. Grooved lines criss-crossed inside vessel to give serrated surface.

Ware: Thick walled, light weight ware. Poor firing. Light brown buff with smokey patches.

Decoration: Band of burnished graphite on the outer surface round the rim.

Use: Grinding tobacco. The leaves are placed in the pot and a stick about a yard long and an inch and a half in diameter is used as a pestle. (krige - museum records)

Name: khitsikiye (krige - museum records)

Figure XXXI No. 174

UCT 38.88 LOBEDU Northern Transvaal Lowveld. Krige

Shape: Small bag-shaped pot with thickened rim and rounded base. H 12.2cms.

Figure XXXI No. 174 (continued)

Ware: Well shaped ware of medium thickness and weight. Well fired.

Decoration: Designs outlined with grooved and incised lines. One band of cross-hatching. Graphite and red ochre applied and burnished. Ochre appears to be applied inside vessel.

Use: Serving beer to guests - a Shangaan custom (Krige - museum records)

Name: letjomele (Krige - museum records)

Figure XXXI No. 175

UCT 38.86 LOBEDU Northern Transvaal Lowveld, Krige.

Shape: Incurved bowl with thickened rim and rounded base. H 15.5cms.

Ware: Ware of medium thickness and weight. Fair firing. Brown buff with smokey patches especially inside.

Decoration: Band of roughly executed deeply incised cross-hatching below a band of burnished graphite 3.5cms. deep.

Use: Small cooking pot for porridge etc. (Krige-museum records)

Name: khepitiana (Krige - museum records)

Figure XXXI No. 176

UCT 38.82 LOBEDU Northern Transvaal Lowveld, Krige

Shape: Spherical pot with thickened rim and rounded base. H 20.5cms.

Ware: Medium thickness and weight. Well shaped. Well fired. Orange buff.

Decoration: Decorated with band and triangle design with grooved lines and coloured with graphite and red ochre. Very well burnished.

Use: for serving beer (Krige - museum records)

Name: thukwana (Krige - museum records)

Figure XXXII No. 177

TVL 61/141 LOBEDU Duiwelskloof, Northern Transvaal

Shape: Spherical pot with thickened rim and rounded base. H 17.5cms.

Decoration: Design outlined with incised lines. Red ochre and graphite coloured. Band of stamped impressions and band of cross-hatching.

Figure XXXII No. 177 (continued)

Use: To serve strong beer to guests - also other beer (Krige - museum records)
Name: thukhwana (Krige - museum records)

Figure XXXII No. 178

UCT 38.89 LOBEDU Northern Transvaal Lowveld, Krige.

Shape: Large open mouthed bowl with rounded rim and rounded base. H 22.5cms.

Ware: Very well formed, evenly finished ware. Medium thickness. Fairly well fired. Burnished inside and out.

Decoration: none

Use: To catch beer when it is squeezed out of beerstrainer. (Krige - museum records)

Name: lebêta (Krige - museum records)

Figure XXXII No. 179

UCT 38.84 LOBEDU Northern Transvaal Lowveld, Krige.

Shape: Small open mouthed bowl with thickened rim and rounded base. H 8.7cms.

Ware: Thick walled ware of medium weight. Not very well finished. Medium firing.

Decoration: Poorly applied graphite inside and out. Better burnish inside.

Use: for serving relish, - also as a cup for drinking marula cider (Krige - museum records)

Name: khiritswana (Krige - museum records)

Figure XXXII No. 180

SAM 8804 LOBEDU Medingen, Pietersburg, Transvaal 1936. Government Ethnologist. Presented September 1962

Shape: Small open mouthed bowl, thickened rim and rounded base. H 8.5cms.

Decoration: Outer surface burnished graphite with band of cross-hatching below band of burnished red ochre.

Use: eating relish (Government Ethnologist - museum records)

Figure XXXII No. 181

UCT 38.80 LOBEDU Northern Transvaal Lowveld, Krige.

Shape: Open mouthed bowl with thickened rim and rounded base. H 11cms. (lid to No. 176)

Ware: Well shaped ware of medium thickness and weight. Mottled orange, brown and black.

Figure XXXII No. 181 (continued)

Decoration: Band of burnished graphite either side of the rim.

Use: Lid, if used for cooking pumpkins or green mealies. Used itself as pot for moroho (relish) to be eaten with porridge. Mainly nuts and various kinds of edible ants and grasshoppers are roasted in this. (Krige - museum records)

Name: morifi (Krige - museum records)

Figure XXXII No. 182

UCT 38.90 LOBEDU Northern Transvaal Lowveld. Krige.

Shape: Open mouthed bowl with thickened rim and rounded base. H 10.5cms.

Ware: Well formed, medium thick ware. Light weight. Medium firing. Catty clay. Deep red brown.

Decoration: Band of grooved patterning below rim on outer surface. Well burnished graphite inside and outside.

Use: Washing (Krige - museum records)

Name: lesabelo (Krige - museum records)

Figure XXXIII No. 183

SAM 8697 HANANWA Leipzig, Blauwberg, Transvaal September, 1962 South African Museum Expedition.

Shape: Large pot with upright neck formed with well-defined point of inflection, rounded rim and rounded base. H 31cms.

Ware: Thick walled, heavy ware. Well fired. Flakes of mica in clay. Light brownish orange. Mat finish except where decorated

Decoration: Grooved lines outlining design of bands and arcs. Graphite, ochre and white material.

Figure XXXIII No. 184

SAM 8698 HANANWA Leipzig, Blauwberg, Transvaal September, 1962 South African Museum Expedition.

Shape: Open mouthed bowl with round rim and flattened base. H 12.2cms.

Ware: Thick walled, heavy ware. Poorly fired. Mica flakes in clay.

Decoration: Band of cross hatching on outside filled with white material. Roughly burnished graphite.

Use: washbasin (potter - museum records)

Name: lesapela (potter - museum records)

Figure XXXIII No. 185

TVL 61/96 HANANWA Blauwberg, Transvaal.

Shape: Open mouthed bowl with rounded rim and flattened base. H 7.5cms.

Ware: Thick walled ware.

Decoration: Band of incised cross-hatching below rim on outside. Coloured with burnished graphite.

Use: Serving vegetables and meat (museum records)

Name: thiswana (museum records)

Figure XXXIII No. 186

TVL 61/95 HANANWA Blauwberg, Transvaal.

Shape: Open mouthed bowl with cut rim and rounded base. H 10cms.

Ware: Fairly thick.

Decoration: Incised cross-hatched band around mouth. Band of ochre. Rest of bowl, inside and out coloured with burnished graphite.

Use: washbasin (museum records)

Name: lefiso (museum records)

Figure XXXIII No. 187

TVL 61/97 HANANWA Blauwberg, Transvaal

Shape: Incurved bowl with thickened rim and rounded base. H 12.5cms.

Ware: Blackened by use.

Decoration: One incised line.

Use: cooking meat and vegetables for six people. (museum records)

Name: pitsana (museum records)

Figure XXXIV No. 188

SAM 8129 TRANSVAAL SOTHO. Koppie Cave, "Holmsleigh" Potgietersrust, Transvaal. August, 1959 J. Rudner.

Shape: Large spherical pot with rounded rim and rounded base. H 31.5cms.

Ware: Roughly finished, heavy pottery. Brown red with large area of smokey black.

Decoration: Two rows stamped impression made with pointed stylus around the mouth.

Figure XXXIV No. 189

TVL 61/98 HANANWA Blauwberg, Transvaal.

Figure XXXXIV No. 189 (continued)

Shape: Large inverted bag-shaped pot with slight inward sloping neck formed with poorly defined point of inflection, rounded rim and rounded base. H 26.5cms.

Decoration: Grooved lines in bands, arcs and cross-hatching. Stamped impressions. White material in lines and stamped impressions.

Use: beerpot for storing and serving (museum-records)

Name: sekukwana (museum records)

Figure XXXXV No. 190

BANTU AFFAIRS DEPARTMENT, Pretoria. BAKONI, Lekgale's location, Pietersburg. Mr. Velcich.

Shape: Beaker pot with thickened rim and flattened base. H 19cms.

Decoration: Decorated with incised lines, graphite and ochre.

Use: Drinking (Mr. Velcich)

Name: tshomela (Mr. Velcich)

Figure XXXXV No. 191

SAM 8829 BAKONI Lekgale's location, Pietersburg Mr. Velcich.

Shape: Open mouthed bowl, rounded rim and flattened base. Inside of vessel scored with grooved and incised lines to give a serrated surface. H 12cms.

Ware: Heavy, thick walled ware. Very well fired. Coarse clay. Brick orange biscuit with slightly grey centre.

Decoration: Graphite applied and lightly burnished around the rim.

Use: grinding snuff (Mr. Velcich)

Figure XXXXVI No. 192

SAM 8132 TRANSVAAL SOTHO Location Cave, Potgietersrust, Transvaal. 1959 B. Maguire.

Shape: Spherical bowl with curved everted neck formed with well-defined point of inflection, rounded rim and rounded base. H 16cms.

Ware: Heavy, thick walled ware. Walls decrease in thickness from base to rim.

Figure XXXXVI No. 193

SAM 8128 TRANSVAAL SOTHO Koppie Cave, "Holmsleigh"
Potgietersrust. August 1959 J. Rudner.

Shape: Deep open mouthed bowl with cut rim and rounded base. H 16cms.

Ware: Very heavy, well shaped ware. Coarse clay. Very weathered.

Figure XXXXVI No. 194

SAM 8130 TRANSVAAL SOTHO, Waterfall Cave, "Amatola",
Potgietersrust. August 1959 J. Rudner.

Shape: Inverted bag-shaped pot with thickened rim and rounded base. H 20.7cms.

Ware: Of medium thickness and weight. Section of biscuit shows orange, white and black clay from outside to inside.

Decoration: Pot is black with very light burnish and a row of notched stamped impressions below the rim.

Figure XXXXVI No. 195

SAM 8132 TRANSVAAL SOTHO, Location cave, Potgietersrust. 1959 B. Maguire.

Shape: Incurved bowl with rounded rim on tapered wall, and rounded base. H 16.2cms.

Ware: Thickness of pottery decreases rapidly above the line of decoration giving impression of a neck in the drawing, actually this is merely due to decrease in thickness.

Decoration: Line of notched stamped decoration below grooved line.

Figure XXXXVI No. 196

SAM 8135 TRANSVAAL SOTHO Location cave, Potgietersrust, 1959. B. Maguire.

Shape: Incurved bowl with rounded rim on tapered wall and rounded base. H 11.2cms.

Ware: Thick walled, heavy ware. Very weathered.

Decoration: Zig-zag dotted lines.

Figure XXXXVI No. 197

SAM 8133 TRANSVAAL SOTHO Location cave, Potgietersrust, Transvaal. 1959 B. Maguire.

Figure XXXVI No. 197 (continued)

Shape: Sherd of pot lid with knob.

Ware: Roughly formed, heavy ware.

Figure XXXVI No. 198

SAM 8134 TRANSVAAL SOTHO Location Cave, Potgietersrust, Transvaal. 1959 B. Maguire.

Shape: Very small open mouthed bowl with rounded rim and rounded base. H 5cms.

Ware: Very weathered. Heavy for size of vessel. Heavy base, decreasing towards rim.

Decoration: Faint stamped impression in band below rim.

Figure XXXVI No. 199

SAM 8132 TRANSVAAL SOTHO Location Cave, Potgietersrust, Transvaal 1959 B. Maguire.

Shape: Open mouthed bowl with rounded rim on tapered wall and rounded base. H 9.5cms.

Ware: Heavy, coarse ware. Thick at base, decreasing towards the rim.

Decoration: Band of stamped decoration leaving a zig-zag pattern unstamped.

Figure XXXVI No. 200

SAM 8131 TRANSVAAL SOTHO. River bed, Blieden's Farm, Potgietersrust, Transvaal. Mr. Blieden.

Shape: Open mouthed bowl with rounded rim and rounded base. H 10.3cms.

Ware: Thick walled ware. Thick base, walls decrease in thickness towards the rim.

Decoration: Deep stamped grooves in design below rim. Below this and inside vessel signs of burnished graphite.

Figure XXXVII No. 201

UCT 29.60 VENDA Northern Transvaal. Stayt Collection.

Shape: Spherical pot with slightly thickened rim and rounded base. H 16.5cms.

Ware: Medium thick ware of medium weight. Fair firing. Deep orangey red.

Decoration: Grooved line above line of stamped impressions made with the end of a grass stalk.

Figure XXXXVII No. 201 (continued)

Decoration: Graphite lightly burnished. Poorly executed.

Use: cooking vegetables (van der Lith 1960)

Name: tshidudu (ndudu) (van der Lith 1960)

Figure XXXXVII NO. 202

UCT 37.31 VENDA Mphephu's kraal, Nzhelele, Louis Trichardt, Transvaal.

Shape: Spherical pot with thickened rim and rounded base. H 17.5cms.

Ware: Thick walled ware. Heavy. Poor firing.

Decoration: Band of arc designs outlined with incised lines. Roughly decorated with graphite and ochre. Burnished surface.

Name: mvhuvhelo (museum records)

Figure XXXXVII No. 203

SAM 8694 VENDA Sinthumule's location, Louis Trichardt, Transvaal. September 1962. South African Museum Expedition.

Shape: Spherical pot with very short upright neck, rounded rim and slightly flattened base. H 16.5cms.

Ware: Well shaped ware of medium thickness and weight. Very well fired. Brown buff.

Decoration: Neatly decorated with bands and arcs outlined with incised lines and coloured with graphite, on a red ochre background.

Figure XXXXVII No. 204

SAM 8830 VENDA Louis Trichardt, Transvaal. Mr. Velcich, Bantu Affairs Department, Pretoria.

Shape: Sub-spherical pot with thickened rim and rounded base. H 14cms.

Ware: Medium thick walled, fairly heavy ware. Poor firing.

Decoration: Grooved and incised lines outlining band and arc design. Haroon colour - ? paint. Band of cross hatching.

Name: lefhsiswana (Sotho) (Velcich - museum records)

Figure XXXXVII No. 205

SAM 8685 VENDA Chief Basengani, Sibasa, Transvaal

Figure XXXVII No. 205 (continued)

September 1962 South African Museum Expedition.

Shape: Spherical pot with thickened rim and flattened base. H 17cms.

Ware: Well shaped ware of medium thickness. Heavy base. Medium firing.

Decoration: Neatly decorated with grooved lines outlining bands and triangles. Ochre and graphite applied and burnished.

Use: beer container (Chief Rasengani - museum records)

Name: tshibyubela (Chief Rasengani - museum records)

Figure XXXVII No. 206

UCT 37.32 VENDA Mphaphu's kraal, Nzhelele, Louis Trichardt, Transvaal.

Shape: Incurved bowl with thickened rim and rounded base. H 13.5cms.

Ware: Heavy ware, roughly formed. Poor firing. Orangey buff. Blackened by use on outside.

Decoration: Five rows of stamped decoration.

Use: ? cooking vegetables (museum records)

Name: tshidudu (museum records)

Figure XXXVII No. 207

UCT 37.34 VENDA Nzhelele, Louis Trichardt, Transvaal.

Shape: Incurved bowl with thickened rim and rounded base. H 15.5cms.

Ware: Medium thick ware, fairly heavy. Poor firing. Blackened outside by use.

Decoration: Two incised lines around widest diameter.

Use: Pot in which milk is kept to become sour (museum records)

Name: tshingo (museum records) records)

Figure XXXVIII No. 208

TVL 35/688 VENDA Mphaphuli, Sibasa, Transvaal.

Shape: Large pot with two mouths. Thickened rim and rounded base. H. approximately 30cms.

Ware: Fairly thin smooth ware.

Decoration: Band and triangles design outlined with incised lines. Coloured with graphite and red ochre.

Use: Said to be used as beerpot by Chief so that he does not drink from same place as those with whom he shares the beer. (museum records)

Name: goubele (museum records)

Figure XXXXVIII No. 209

AFRIK 59/2322A VENDA Jacques.

Shape: Open mouthed bowl with cut rim and rounded base. H 12.5cms.

Ware: Band and triangle design outlined with incised lines, filled with white coloured material. Band of cross hatching around rim outside. Incised bowl burnished graphite.

Use: for grinding millet (museum records) This is more likely to be a washbasin for men - sambelo

Figure XXXXVIII No. 210

AFRIK 60/1628 VENDA Phiphidi Falls, Zoutpansberg 1959 Dr. A.J. Clement.

Shape: Open mouthed bowl with thickened rim, rounded base and four legs. H 13.3cms.

Decoration: Both inside and outside decorated with geometric designs coloured with graphite and ochre. Grooved lines and hatched bands.

Figure XXXXVIII No. 211

AFRIK 58/1650B VENDA Lent by Mrs. Bubole.

Shape: Open mouthed bowl with thickened rim and slightly flattened base. H 11cms.

Decoration: Outside decorated with designs outlined with grooved lines patterned with cross-hatching over which a white material has been rubbed. Graphite and ochre colour designs. Inside of bowl well burnished graphite.

Figure XXXXVIII No. 212

TVL 61/172 VENDA Mphephu's, Louis Trichardt, Transvaal.

Shape: Bag-shaped sub-carinated pot with everted neck formed with well defined point of inflection, rounded rim and rounded base. H 15.5cms.

Ware: Fairly thick pottery.

Decoration: Arc and triangle design outlined with incised lines and coloured with graphite and ochre. Surface burnished.

Use: drinking beer (museum records)

Name: dzhomela (museum records)

Figure XXXIX No. 213

BUL 2032 LEMBA, Made for VENDA, Mphophu's, Zoutpansberg. Collected N. Jones.

Shape: Large spherical pot with thickened rim and slightly flattened base. H 36cms.

Decoration: Band and triangle design outlined with incised lines and coloured with graphite and ochre. Burnished.

Figure XXXIX No. 214

TVL 61/173 VENDA Mphophu's, Louis Trichardt.

Shape: Spherical pot with upright neck formed with poorly defined point of inflection, rounded rim and rounded base. H 23.5cms.

Decoration: Band and triangle design outlined with wide grooved lines. Coloured with ochre and graphite.

Use: Preparing sour porridge before cooking (museum records)

Name: mvuvhelo (mvhuvhelo) (museum records)

Figure L No. 215

BWYO 2033 LEMBA Mphophu's, Zoutpansberg, Collected N. Jones.

Shape: Large spherical pot with thickened rim and rounded base. H 32.5cms.

Decoration: Band and triangle design outlined with grooved lines and coloured with graphite and ochre.

Figure L No. 216

AFRIK 60/1629 VENDA Phiphidi Falls, Zoutpansberg. 1959.

Shape: Pot with double bowl ("calabash shaped") with thickened rim and rounded base. H 28cms.

Decoration: Band and triangle design outlined with incised lines and coloured with graphite and ochre.

Figure LI No. 217

UCT 37/18 VENDA Mphophu's kraal, Nzhelele, Louis Trichardt, Transvaal.

Shape: Open mouthed bowl with thickened rim and rounded base. H 13cms.

Figure LI No. 217 (continued)

Ware: Heavy, fairly thick walled ware. Roughly made. Poor firing.
Decoration: Grooved cross-hatched band around the mouth of the bowl. Outer surface burnished red ochre, also inside mouth of bowl.
Use: washbasin (van Warmelo 1936)
Name: sambelo (museum records)

Figure LI No. 218

SAM 8695 VENDA Sinthumule's location, Louis Trichardt. September 1962 South African Museum Expedition.
Shape: Beaker with double bowl ("calabash-shaped") thickened rim and flattened base. H 15cms.
Ware: Fairly well formed ware of medium thickness. very well fired. Network of surface crackling.
Decoration: Coloured with red ochre and graphite and burnished.
Use: Drinking vessel (seller - museum records)
Name: dzhomela (seller - museum records)

Figure LI No. 219

UCT 37/33 VENDA Mphephu, Nzhelele, Louis Trichardt Lestrade.
Shape: Incurved bowl with short upright neck formed with poorly defined point of inflection, rounded rim and rounded base. H 12.5cms.
Ware: Unfired. Coarse clay of a green/yellow colour. Thick and heavy. Burnished inside and outside.
Decoration: Band of burnished graphite below rim. Band of incised hatching between two grooved lines below this.
Name: kududu (museum records)

Figure LI No. 220

UCT 37.30 VENDA Mphephu, Nzhelele, Louis Trichardt. Lestrade.
Shape: Small spherical pot with thickened rim and rounded base. H 11.7cms.
Ware: Well shaped ware of medium thickness and weight. Poor firing.
Decoration: none. Blackened by use.

Figure LI No. 220 (continued)

Use: "Earthenware drinking mug of Tonga manufacture"
(van Warmelo 1936)
Name: dzhomela (museum records)

Figure LI No. 221

UCT 29.59 VENDA Northern Transvaal. Stayt Collection.

Shape: Small open mouthed bowl with thickened rim and slightly flattened base. H 10.5cms. Serrated inner surface made by cross-hatching grooved lines.

Ware: Well formed, thin walled, light weight ware.

Decoration: One lightly grooved line.

Figure LI No. 222

SAM 8696 VENDA Sinthumule's Location, Louis Trichardt. September 1962 South African Museum Expedition.

Shape: Open mouthed bowl with flattened base and slightly thickened rim. H 10cms.

Ware: Very well shaped ware of medium thickness and weight. Very well fired.

Decoration: Coloured black with graphite inside and outside. Well burnished. Upper rim coloured with ochre.

Figure LI No. 223

UCT 37.35 Mphephu, Nzhelele, Louis Trichardt. Lestrade.

Shape: Small open mouthed bowl with flattened rim on tapered wall and rounded base. H 8cms.

Ware: Heavy thick ware. Unfired.

Decoration: Outside burnished graphite. Inside red ochre design on burnished graphite background.

Use: serving vegetables to men. (Van der Lith 1960)

Name: ndongwana (museum records)

Figure LI No. 224

SAM 8693 VENDA Sinthumule's Location, Louis Trichardt. September 1962 South African Museum Expedition.

Figure LI No. 224 (continued)

Shape: Open mouthed bowl with rounded rim and rounded base. H 12cms.

Ware: Thick walled, heavy ware. Fair firing. Orangey brown, Even, well shaped ware.

Decoration: On the outside a band of burnished graphite below the mouth, below which a second band, roughly the same width of burnished red ochre. Inside an incised asymmetrical cross coloured with graphite on a burnished ochre background.

Figure LI No. 225

TVL 61/46 VENDA Mphephu, Nzhelele, Louis Trichardt

Shape: Small open mouthed bowl with rounded rim and rounded base. H 7cms.

Ware: Fairly thick ware.

Decoration: Outside surface coloured with burnished ochre except for a narrow band of graphite around the mouth. Inside entirely burnished graphite.

Use: For serving meat and vegetables or drinking marula beer (museum records)

Name: seriswana (Sotho) / tshidongo (Venda) (museum records)

Figure LII No. 226

BWYO 2029 LEMBA Belingwe, S. Rhod. N. Jones.

Shape: Pot with upright neck formed with poorly defined point of inflection, rounded rim and dimple base. H 30cms.

Decoration: Roughly grooved decoration at base of neck.

Figure LII No. 227

UCT 37.29 LEMBA Lemana Mission, Transvaal. Lestrade.

Shape: Sub-carinated pot with thickened rim and rounded base. H 14cms.

Ware: Well shaped ware of medium thickness and weight. Very well fired. Orangey brown. Network of surface cracks. Many irregularities in clay.

Decoration: Grooved and stamped design.

Figure LII No. 228

BWYO 2047 LEMBA used by VENDA Mphephu, Zoutpansberg.
N. Jones.

Shape: Pot with upright neck formed with well defined point of inflection, thickened rim and slightly flattened base. H 21.5cms.

Decoration: Grooved and stamped band and triangle design. Application of graphite and ochre. Burnished.

Figure LII No. 229

BWYO 2029 LEMBA Belingwe District, S. Rhod. N. Jones.

Shape: Bag-shaped pot with thickened rim and rounded base. H 18.6cms.

Decoration: Grooved and stamped designs, coloured with burnished graphite and burnished red ochre.

Figure LII No. 230

BWYO 2031 LEMBA Belingwe. S. Rhod. N. Jones.

Shape: Open mouthed bowl with slightly thickened rim and rounded base. H 9.5cms.

Decoration: Band of hatched grooved lines coloured with a white material. Red ochre and graphite applied and burnished. Inside of vessel decorated with burnished ochre band on a graphite burnished background.

Figure LII No. 231

BWYO 5079 LEMBA Belingwe Reserve, Rubabvu Mission School. S. Rhod. v. Sicard 1949.

Shape: Small incurved bowl with rounded edge and rounded base. H 9cms. Inside of bowl divided into two sections with clay partition.

Decoration: Outer surface decorated with incised triangles and band of widely spaced cross-hatching. Coloured with graphite and ochre. Burnished.

Use: Belish pot - modern but in traditional design. (museum records)

Figure LIII No. 232

SAM 8690 LEMBA, Sibasa, Mphego's Location, Transvaal. September 1962. South African Museum Expedition.

Figure LIII No. 232 (continued)

- Shape: Large open mouthed bowl, with rounded rim and rounded base. H 21cms.
- Ware: Heavy even-walled ware. Well fired. Deep red with smokey patches. Serrated inner surface produced by cross-hatching deeply grooved lines.
- Use: For grinding monkey nuts (seller - museum records)
- Name: mugurudu (seller - museum records)

Figure LIII No. 233

- SAM 8805 LEMBA Sibasa, Transvaal. 1936 Government Ethnologist. Presented to museum September 1962.
- Shape: Small open mouthed bowl, rounded rim, slightly thickened inside, and rounded base. H 8cms.
- Ware: Well shaped medium thick pottery. Fairly heavy.
- Decoration: Band of grooved cross-hatching filled with white material on outer surface. Below this band of burnished ochre outlined with incised lines. Burnished graphite over inside and rest of outer surface.
- Name: ndongwana (museum records)

Figure LIII No. 234

- UCT 39/1 LEMBA Lestrade.
- Shape: Pot with thickened rim and rounded base. H 19.5cms.
- Ware: Very heavy weight ware of medium thickness. Poor firing.
- Decoration: Incised bands and triangles, the latter being diagonally hatched. Band of stamped impressions. Pot coloured with burnished graphite and red ochre. Poor standard of decoration.

Figure LIII No. 235

- SAM 8805 LEMBA Tshimbupfe, Sibasa, Transvaal. Government Ethnologist, Presented to museum in September 1962.
- Shape: Spherical pot with rounded rim and slightly flattened base. H 14cms.
- Ware: Well shaped, thin walled, light weight ware. Very well fired. Deep red orange.

Figure LIII No. 235 (continued)

Decoration: Incised designs coloured alternately with graphite and red ochre.

Use: drinking from (van Warmelo 1935)

Name: dzhomela (museum records)

Figure LIII No. 236

SAN 8691 LEMBA Nphego's location, Sibasa, Transvaal. September 1962 South African Museum Expedition.

Shape: Small spherical pot with upright neck formed with poorly defined point of inflection, rounded rim and rounded base. H 13.5cms.

Ware: Medium heavy ware with walls of medium thickness. Very well fired. Dark brown buff.

Decoration: Band of burnished graphite below mouth bounded by one incised line and two rows of stamped impressions.

Name: Isibindu (seller - museum records)

Figure LIII No. 237

SAN 8801 LEMBA Tshimbupfo, Sibasa, Transvaal. 1936. Government Ethnologist. Presented September 1962.

Shape: Spherical pot with slightly thickened rim and flattened base. H 19cms.

Ware: Beautifully formed, thin walled, light weight ware. Very well fired.

Decoration: Neatly decorated with grooved band and triangles design. Coloured with graphite and ochre and well burnished.

Name: mvuvhelwana (Government Ethnologist - museum records)

Figure LIV No. 238

SAN 8942 CHOPI Makupulane, Sul do Save, Mozambique June 1963 South African Museum Expedition.

Shape: Pot with everted neck formed with well-defined point of inflection, rounded rim and rounded base. Height 19.8 cms.

Ware: Crudely shaped, uneven ware. Very well fired. Very light ash colour with light orange tinge and smokey patches.

Decoration: Crude pattern of short grooved lines below the neck.

Name: shikediana. (seller - museum records)

Figure LIV No. 239

TVL 6835 LENG/CHOPI Maseyeni, Sul do save,
Mozambique. 1924

Shape: Pot with upright neck formed with poorly-
defined point of inflection, rounded rim
and rounded base. H 15.4cms.

Ware: Brown with black patches.

Name: djomeia (museum records)

Figure LIV No. 240

TVL 6898 LENG/CHOPI Maseyeni, Sul do Save,
Mozambique. 1924

Shape: Open mouthed bowl with cut rim and rounded
base. H 9cms.

Ware: Fairly thick brown ware with good burnish.

Use: food bowl (museum records)

Figure LV No. 241

SAM 8766 BITONGA Inhambane Market, Sul do Save,
Mozambique. September 1962 South African Museum
Expedition.

Shape: Large pot with short everted neck formed with
well-defined point of inflection, cut rim
and round base. H 32.2cms.

Ware: Well shaped, unevenly finished ware. Very
well fired. Large smokey areas. Light in
weight.

Decoration: Three-quarters of outer surface colour-
ed red and burnished.

Use: cooking pot. (seller - museum records)

Name: khali (seller - museum records)

Figure LV No. 242

SAM 8775 BITONGA Maxixe Market, Sul do Save,
Mozambique. September 1962 South African Museum
Expedition.

Shape: Bowl with carination at widest diameter with
everted neck formed with well-defined point
of inflection, cut rim and rounded base.
H 12.5cms.

Ware: Well shaped, crudely finished ware of medium
thickness and weight. Medium well fired.
Deep orange with smokey patches.

Decoration: Red colour applied inside.

Name: gikalange (seller - museum records)

Figure LV No. 243

SAM 8767 BITONGA Inhambane Market, Sul do Save, Mozambique, September 1962. South African Museum Expedition.

Shape: Shallow sub-carinated bowl with short, straight, everted neck formed with well-defined point of inflection, cut rim and rounded base. H 11.25 cms.

Ware: Fairly heavy ware of medium thickness.

Decoration: Red colour applied in very liquid form on inside of neck and upper section of body.

Name: gikalange (seller - museum records)

Figure LVI No. 244

SAM 8768 BITONGA Inhambane Market, Sul do Save, Mozambique. September 1962. South African Museum Expedition.

Shape: Large open-mouthed bowl with flattened thickened rim and rounded base. H 18.5cms.

Ware: Roughly finished ware of medium thickness. Fairly heavy. Very well fired.

Decoration: Red colour applied outside and on rim.

Use: cooking (seller - museum records)

Name: tinzala (seller - museum records)

Figure LVII No. 245

SAM 6070 SHONA/TONGA Sebungwe, Rhodesia. 1939 exchanged with National Museum, Bulawayo (at least fifty years old at time of exchange)

Shape: Pot with inward sloping neck formed with poorly-defined point of inflection, thickened flattened rim and rounded base. H 30 cms.

Ware: Well shaped ware of medium thickness.

Decoration: Colours faded. Graphite and ochre. Designs incised and stamped. Shiny finish due to an application on outer surface.

Figure LVII No. 246

SAM 2068 SHONA Rhodesia. 1916 Dr. Melle

Shape: Pot with cut rim and rounded base. H 19.7cms.

Ware: Well shaped ware with thick walls. Comparatively light. Medium firing. Black inside and out, except base which is grey buff.

Use: 1. cooking in small quantities. 2. serving leftovers. 3. carrying food to fields. 4. can be used as food bowl when nothing else is available (museum records)

Name: tsayiva (museum records)

Figure LVII No. 247

SAM 7949 "Muskimuembe", 9 miles from Marandellas.
S. Rhod. 1958. J. Read.

Shape: Sherd of pot with well developed straight neck, thickened flattened rim and probably double carination.

Ware: Well shaped, thick ware. Section of biscuit shows grey centre with buff either side.

Decoration: Graphite applied and burnished.
Grooved line at narrowest diameter of body.

Figure LVII No. 248

BWYO 2054 ROMO Dzete Tribe Charter District,
S. Rhod. Stead.

Shape: Small inturned bowl with cut rim and flattened base. H 11.3cms.

Decoration: Band of graphite around mouth on outer surface.

Name: ohikadiana che munzira - "smallest pot without lip(? neck) - with lip would be called chimbiya" (Stead - museum records)

Figure LVII No. 249

BWYO no number. SHONA Chindemora Reserve,
S. Rhod. N. Jones.

Shape: Spherical pot with well developed upright neck formed with well-defined point of inflection, and rounded base. H 24cms.

Decoration: Design outlined with deep jagged incised lines. Graphite and ochre applied alternately and burnished.

Figure LVIII No. 250

SAM 8956 MARI Charumbira, Victoria Reserve,
S. Rhod. June 1963 South African Museum Expedition.

Shape: Large spherical pot with tall slightly everted neck formed with poorly defined point of inflection, and cut rim and flattened base. H 40.7cms.

Ware: Very smooth finish to vessel. Heavy in weight. Light orange buff with smokey patches.

Decoration: Two grooved lines around the base of the neck.

Use: beer container (potter - museum records)

Name: nyenjere (potter - museum records)

Figure LVIII No. 251

SAM 1824 SHONA Found on grave. Rhodesia 1916
Dr. Melle.

Shape: Spherical bowl with curved, everted neck formed with well-defined point of inflection, rounded rim and rounded base. H 10.8 cms.

Ware: Well shaped ware of medium thickness and light weight.

Decoration: Grooved line around base of neck. Burnished graphite over outer surface and inside neck.

Figure LVIII No. 252

SAM 1824 SHONA Found on grave. Rhodesia 1916
Dr. Melle

Shape: Spherical bowl with everted neck formed with well-defined point of inflection, flattened rim and rounded base. H 10.4 cms.

Decoration: Burnished graphite.

Figure LVIII No. 253

SAM 7948 ? SHONA Found in tunnel grave on koppie on Musikimembe Farm, Rhodesia. 1958 J. Read.

Shape: Pot with everted neck formed with poorly-defined point of inflection, rounded rim and rounded base. H 13.2 cms.

Ware: Evenly formed from coarse clay.

Decoration: Band of stamped or incised notched impressions around base of neck, with first downward stroke deeper than the second. Burnished graphite.

Figure LIX No. 254

BWYO 5456 TONGA Wankie, road beside Falls, about 170 miles from Bulawayo, Rhodesia.

Shape: Carinated pot with carination at widest diameter, short upright neck formed with poorly-defined point of inflection, rounded rim and rounded base. H 24.2 cms.

Decoration: Grooved design coloured with ochre and graphite. Double row stamped impressions at carination.

Figure LIX No. 255

CAM 1905? Rhodesia. Haddon

Shape: Wide-mouthed spherical pot with tall slightly everted neck formed with well-defined point of inflection, cut rim and rounded base. H 19 cms.

Figure LIX No. 255 (continued)

Decoration: Graphite and ochre applied in designs.

Figure LIX No. 256

CAM E. 1905-497 MAKARANGA Umtali, Rhodesia.
Haddon.

Shape: Inverted bag-shaped bowl with curved, everted neck formed with well-defined point of inflection, rounded rim on tapered wall and rounded base. H 11.5 cms.

Decoration: Grooved design. Coloured with red ochre and graphite.

Figure LX No. 257

BWYO 5814 KALANGA Mashaba, Zimbabwe, Fort Victoria, Rhodesia.

Shape: Incurved bowl (borderline case) with out rim and flattened base. H 19 cms.

Decoration: Grooved and incised lines outline design which is patterned with incised cross-hatching, stamped impressions made with the end of a grass stalk and the application of graphite and red ochre.

Use: cooking vegetables (museum records)

Name: anjana (museum records)

Figure LX No. 258

BWYO 5815 KALANGA Mashaba, Fort Victoria, Rhodesia.

Shape: Small open-mouthed bowl with out rim and pedestal base. H 11 cms.

Decoration: Band of graphite around mouth on outer surface. Below this two grooved lines outline an incised cross-hatched band.

Use: for drinking beer or holding relish (museum records)

Name: cimbia (museum records)

Figure LX No. 259

SAL. no number KOREKORE Lomagundi, Darwin, Rhodesia 1946.

Shape: Deep incurved bowl with rounded base, H 15.5 cms.

Ware: Blackened from use.

Decoration: Three pairs of bosses spaced on raised band which is cross-hatched, below mouth.

Figure LX No. 260

BWYO 2049 KALANGA Gwai Reserve, Rhodesia.
N. Jones.

Shape: Spherical pot with rounded rim and slightly flattened base. H 15 cms.

Decoration: Upper section coloured with burnished graphite and ochre in alternate bands.

Figure LX No. 261

SAL 45.7.1 KOREKORE Sinoia, Rhodesia.

Shape: Small incurved bowl with curved everted neck formed with poorly-defined point of inflection, rounded rim and pedestal base. H 10.25 cms.

Decoration: Five pairs of twin lugs at intervals on the outer surface and four pairs of "pimples" on the inner side of the neck.

Figure LX No. 262

SAL 46.34.3 TONGA Mkoto, now displaced to Two Tree Hill Compound, Sinoia, Rhodesia.

Shape: Small incurved bowl with out rim and rounded base. H 8 cms.

Decoration: Band of four grooved lines.

Figure LX No. 263

BWYO 2050 KALANGA Bazha, Matopo Hills, Rhodesia.
N. Jones.

Shape: Deep spherical bowl with curved, everted neck formed with poorly-defined point of inflection and rounded base. H 16.5cms.

Decoration: Incised line of vandyk. Graphite, and ochre coloured design.

Figure LX No. 264

BWYO 2027 KALANGA Gwai Reserve, Rhodesia. N. Jones.

Shape: Sub-spherical bowl with everted neck formed with poorly-defined point of inflection, rounded rim and rounded base. H 13.4 cms.

Decoration: Design outlined with very faint incised lines which could have been done after firing. Coloured with graphite and ochre.

Figure LX No. 265

SAL 6114.1 ZEZURU Lake McIlwaine, behind Bushman's Point, Rhodesia. (not older than 100 years -museum records).

Figure LX No. 265 (continued)

Shape: Spherical pot with tall upright neck formed with well-defined point of inflection, rounded rim and rounded base. H 19 cms.

Decoration: Deeply stamped line in zig-zag round vessel with an incised line either side. Ochre and graphite coloured.

Figure LXI No. 266

SAM 8970 MANYIKA Inyanga Reserve (people from Mutassa Reserve, Umtali) Inyanga, Rhodesia. June 1963 South African Museum Expedition.

Shape: Spherical pot with tall, curved, everted neck formed with well-defined point of inflection, cut rim and rounded base. H 26.5cms.

Ware: Fairly thick ware. Poorly fired. Brown.

Decoration: Design outlined with grooved lines. Painted red and black with enamel paint.

Use: storing beer (potter - museum records)

Name: kakaha (potter - museum records)

Figure LXI No. 267

SAM 8972 BUDJGA Near Bwonya School, Mtoko Reserve, Mtoko, Rhodesia. June 1963 South African Museum Expedition.

Shape: Spherical pot with upright neck formed with well-defined point of inflection, rounded rim and dimple base. H 19.8cms.

Ware: Beautifully shaped and finished ware. Poor firing. Brown.

Decoration: Grooved at base of neck with thumb when smoothing neck. Coloured with blue enamel paint.

Name: kapfuko (seller-museum records)

Figure LXI No. 268

SAL 49.39 SHAWASHA Chishawasha, Rhodesia.

Shape: Narrow-mouthed barrel-shaped pot with dimple base. H 20.5cms.

Figure LXI No. 269

BWYO 58.64 BARWE Ziwa Farm, Inyanga. Made by potter for Mr. F.O. Bernhard.

Shape: Pot with tall, curved, everted neck formed with poorly-defined point of inflection, thickened rim and rounded base. H 26 cms.

Figure LXI No. 269 (continued)

Decoration: All over pattern of raised bands, probably moulded. Graphite applied round mouth.

Figure LXI No. 270

CAM E. 1906.493 KARANGA Umtali, Rhodesia. Haddon.

Shape: Small bowl with short, curved, everted neck formed with poorly-defined point of inflection, rounded rim and rounded base. H 9.5 cms.

Decoration: Burnished ochre.

Figure LXII No. 271

SAM 6070 SHONA Sebungwe, Rhodesia 1939, Exchange National Museum, Bulawayo.

Shape: Inverted bag-shaped pot with inward-sloping neck formed with poorly-defined point of inflection, thickened rim and rounded base. H 24.8 cms.

Ware: Medium thick and heavy ware. Well fired.

Decoration: Incised design coloured with red ochre and graphite. Band of stamped impressions at base of neck. Faded colours and poor burnish.

Use: beer or water pot (museum records)

Figure LXII No. 272

From farm in Ayreshire Hills, Rhodesia. Private collection.

Shape: Deep open-mouthed bowl with cut rim on tapered wall and rounded base. H 9 cms.

Decoration: Band of stamped oval impressions inside mouth.

Figure LXII No. 273

SAM 2076 ? SHONA Rhodesia, 1916. Dr. Melle.

Shape: Deep bag-shaped bowl with rounded rim and rounded base, H 17.1 cms.

Ware: Evenly formed ware of medium thickness. Fairly heavy pottery. Upper three-quarters of outside surface blackened by smoke.

Decoration: Raised applied band with cross-hatching around mouth. Ends of band turn at right angles towards base leaving a gap of about 2.5 cms.

Figure LXII No. 274

SAM 1824 SHONA Salisbury, Rhodesia.

Shape: Inverted bag-shaped pot with tall, curved everted neck formed with well-defined point of inflection, and rounded base.
H 16.25 cms.

Ware: Medium thick ware, light in weight.
Brown/grey.

Decoration: Band of burnished graphite.

Figure LXII No. 275

SAM 6070 Sebungwe, Rhodesia, 1939. Exchange National Museum, Bulawayo.

Shape: Inverted bag-shaped pot with tall, curved everted neck formed with poorly-defined point of inflection, thickened flattened rim and rounded base. H 21 cms.

Ware: Well shaped, thickwalled ware. Fairly light in weight. Well fired. Coarse clay with flakes of mica.

Decoration: Ochre and graphite colour. Grooved and stamped designs.

Use: beer or water pot (museum records)

Figure LXII No. 276

CAM 54.37 ? SHONA 20 miles S.E. of Salisbury on Norton-Salisbury Road. Pre-occupation.

Shape: Small bowl with short, curved, everted neck formed with poorly-defined point of inflection, rounded rim and flattened base. H 7.5 cms.

Decoration: Two pairs of applied knobs on outer surface and two sets of three and two sets of four inside the rim. Grooved lines around base of neck. Black finish.

Figure LXII No. 277

SAM 1823 SHONA Salisbury, found on grave. Melle.

Shape: Small wide-mouthed bowl with rounded rim and rounded base, H 10 cms.

Ware: Medium thick walled, light weight ware.
Fair firing. Brown buff.

Decoration: Band of burnished graphite around mouth.

Figure LXIII No. 278

BJYO 2052 ROMO Dzete Tribe, Charter District, Rhodesia. Stead.

Shape: Wide-mouthed spherical pot with short, curved, everted neck formed with well-defined point

Figure LXIII No. 278 (continued)

of inflection, thickened flattened rim
and rounded base. H. 20.5 cms.

Decoration: Grooved line at base of neck. Ochre
and graphite applied and burnished.

Use: small cooking pot (museum records)

Name: hadjgana (museum records)

Figure LXIII No. 279

BWYO 5158 SHONA Jawa's kraal, Mtilikwe Reserve,
Victoria, Rhodesia.

Shape: Wide-mouthed pot with tall straight neck
formed with well-defined point of inflection,
and rounded base. H. 20.5 cms.

Decoration: Band of incised cross-hatching between
two grooved lines below neck.

Figure LXIII No. 280

BWYO 2061 NDAU Chikore, Rhodesia.

Shape: Sub-spherical pot with short, upright
neck formed with poorly-defined point of
inflection, rounded rim and rounded base.
One applied handle. H. 21 cms.

Ware: Very thin and light ware.

Decoration: Incised lines outlined triangle and band
design patterned with cross-hatching.

Figure LXIII No. 281

BWYO 5455 TONGA Wankie, beside Falls, 70 miles
from Bulawayo, Rhodesia.

Shape: Incurved bowl with cut rim and rounded base.
H. 16.2 cms.

Ware: Roughly finished. Coarse clay.

Decoration: Incised zig-zag bands coloured alternately with
graphite and ochre and burnished. Lines themselves
are filled with white material.

Figure LXIII No. 282

BWYO 2064 NDAU Chikore, Rhodesia.

Shape: Bowl with curved, everted neck formed with
poorly-defined point of inflection, rounded
rim and rounded base. H. 31.1 cms.

Ware: Very light weight, thin walled ware.

Decoration: Triangular incised design patterned with
cross-hatching.

Figure LXIV No. 287

SAM 8976 ZEZURU Chiweshe, Mangwehe Reserve, Mrewa, Rhodesia. June 1963 South African Museum Expedition.

Shape: Deep incurved bowl with rounded rim and rounded base. H 15.5 cms.

Ware: Well shaped ware of medium weight and thickness. Very well fired. Brown buff with smokey patches. Burnished surface.

Use: for vegetables (potter - museum records)

Name: chikari (potter - museum records)

Figure LXIV No. 288

SAM 7214 NDAU Maringua's kraal, Sabi-Lundi, Rhodesia. 1952. B. Carp.

Shape: Spherical pot with curved, upright neck formed with poorly-defined point of inflection, thickened rim and rounded base. H 17.5 cms.

Ware: Well shaped, roughly finished ware of medium thickness and weight. Medium firing.

Decoration: Grooved lines outline band and triangles design patterned with cross-hatching. White material fills outlines, background coloured with burnished graphite.

Name: dub/dubi (museum records)

Figure LXIV No. 289

SAM 7213 NDAU Maringua's kraal, Sabi-Lundi, Rhodesia. 1952. B. Carp.

Shape: Spherical pot with curved, everted neck formed with poorly-defined point of inflection, rounded rim and rounded base. H 20.25 cms.

Ware: Well shaped ware of medium thickness and weight.

Decoration: Triangular design outlined with lightly grooved lines filled with white material. Coloured with graphite.

Name: dubi/dubi (museum records)

Figure LXV No. 290

SAM 8977 ROSWI Near Mafuta, Chiduku Reserve, Busaps Rhodesia. June 1963. South African Museum Expedition.

Shape: Large spherical pot with curved, everted neck formed with well-defined point of inflection, flattened thickened rim and rounded base. H 30 cms.

Figure LXV No. 290 (continued)

Ware: Well shaped ware of medium thickness and weight. Very well fired. Brown colour.

Decoration: Design outlined with deeply incised lines. Coloured with red and black enamel paint.

Use: fetching water (potter - museum records)

Name: chirongo (potter - museum records)

Figure LXV No. 291

SAM 8978 BOSWI Near Mafuta's kraal, Chiduku Reserve, Rusape, Rhodesia. June 1963. South African Museum Expedition.

Shape: Deep incurved bowl with cut rim and rounded base. H 18.5 cms.

Ware: Lightly burnished without applied colour. Very well fired and evenly formed.

Use: For cooking (seller - museum records)

Name: sawia (Ros.) / mokati (Hung.) (seller - museum records)

Figure LXV No. 292

SAM 7218 NDAU Maringa's kraal, Sabi-Lundi, Rhodesia.

Shape: Wide-mouthed spherical bowl with short, curved, everted neck formed with poorly-defined point of inflection, rounded rim on tapered wall and rounded base. H 19.8 cms.

Ware: Roughly shaped, thin walled, light weight ware. Well fired. Light orange.

Decoration: Band of incised cross-hatching below neck.

Name: chikari (museum records)

Figure LXVI No. 293

BWYO 2028 KALANGA Plumtree, Rhodesia. N. Jones

Shape: Large spherical pot with curved, everted neck formed with poorly-defined point of inflection, out rim and rounded base. H 34 cms.

Decoration: Incised designs coloured with red ochre and graphite. Burnished.

Use: water pot (museum records)

Figure LXVI No. 294

BWYO 5813 KALANGA Mashaba, Zimbabwe, Victoria Rhodesia.

Shape: Spherical pot with tall, upright neck formed

Figure LXVI No. 294 (continued)

with poorly defined point of inflection,
cut rim and dimple base. Añño has handle.
H 29.5 cms.

Decoration: Designs outlined with grooved and
incised lines. Coloured with graphite and
red ochre. Burnished.

Use: carrying beer (museum records)

Name: pfuko (museum records)

Figure LXVI No. 295

BWYO 2057 ROMO Dzete Tribe, Charter District,
Rhodesia. Stead.

Shape: Large spherical pot with straight, upright
neck formed with poorly-defined point of
inflection, rounded rim and rounded base.
H 31.5 cms.

Decoration: Grooved triangular pattern coloured
with graphite and ochre.

Use: Cooking pot for meat or porridge, in large
quantities only (museum records)

Name: chikati (Stead - museum records)

Figure LXVI No. 296

BWYO 2056 ROMO Dzete Tribe, Charter District,
Rhodesia. Stead.

Shape: Large inverted bag-shaped pot with curved,
everted neck formed with well-defined
point of inflection and flattened base.
H 32.5 cms.

Decoration: Grooved line around base of neck.
Incised lines outlining triangular design
coloured with graphite and ochre.

Use: carrying beer or water (museum records)

Name: chirongo (museum records)

Figure LXVI No. 297

BWYO 7857 ? VALLEY TONGA Siachelaba's kraal,
Sebungwe, Rhodesia.

Shape: Large inverted bag-shaped pot with upright
neck formed with poorly-defined point of
inflection, and rounded rim and rounded
base. H 35.5 cms.

Decoration: Incised triangular design coloured with
ochre and graphite. Stamped band around
the base of the neck.

Figure LXVIII No. 303

SAM 3776 KWANYAMA Ovamboland 1921. K. Barnard.
Shape: Spherical pot with curved everted neck formed with well-defined point of inflection, cut rim and almost pointed base. H 25.7 cms.
Ware: Medium thick, heavy ware. Poor firing.

Figure LXVIII No. 304

SAM 3777 KWANYAMA Ovamboland, 1921. K. Barnard.
Shape: Inverted bag-shaped pot with inturned neck formed with poorly-defined point of inflection, cut rim and rounded base. H 11.4 cms.
Ware: Well shaped, thin walled, fairly light pottery. Medium firing. Smooth, unburnished finish.
Decoration: Grooved line at base of neck.
Name: ombia (museum records)

Figure LXVIII No. 305

SAM 8474 KWANYAMA Nehemiah's place, near Omaf, Ovamboland. July 1961. Ethnologist, South African Museum.
Shape: Spherical pot with tall, curved, upright neck formed with well-defined point of inflection, cut rim and rounded base. H 17.5 cms.
Ware: Well shaped ware. Thin walled and light in weight. Poor firing. Matt surface. Grey with black patches.

Figure LXVIII No. 306

SAM 3776 KWANYAMA Ovamboland. 1921 K. Barnard.
Shape: Inverted bag-shaped pot with short, inward-sloping neck formed with well-defined point of inflection, cut rim and rounded base. H 31 cms.
Ware: Well shaped ware of medium thickness and weight. Medium firing. Smooth regular walls. Unburnished.
Decoration: Grooved line at base of neck.

Figure LXIX No. 307

SAM 3777 KWANYAMA Ovamboland 1921. K. Barnard.
Shape: Inverted bag-shaped pot with tall, upright neck formed with poorly-defined point of inflection, flattened rim and rounded base H 13.8 cms.

Figure LXIX No. 307 (continued)

Ware: Well shaped ware of medium thickness.
Matt surface. Well fired. Grey.
Decoration: Grooved lines at base of neck.

Figure LXIX No. 308

SAM 8475 KWANYAMA Nehemiah's place, near Omaf, Ovamboland. July 1961. Ethnologist, South African Museum.

Shape: Inverted bag-shaped pot with tall, straight, upright neck formed with well-defined point of inflection, rounded rim and rounded base. H 17.5 cms.

Ware: Well shaped, roughly finished, thin walled ware. Light in weight. Poor firing. Mottled orange, grey and brown.

Name: ositoo (potter - museum records)

Figure LXIX No. 309

SAM 4097 KUALUTHI Ovamboland 1923. South West African Expedition.

Shape: Flask-shaped pot with tall, curved, everted neck formed with poorly-defined point of inflection, rounded rim and flattened base. H 25.5 cms.

Ware: Medium thick-walled. Fairly well fired. Burnished surface.

Decoration: Band of short horizontal grooved lines around neck. Applied lumps.

Name: ositoo (museum records)

Figure LXIX No. 310

SAM 4107 KOLONKATHI Ovamboland 1923. South West Africa Expedition.

Shape: Spherical pot with short, upright neck formed with poorly-defined point of inflection, flattened thickened rim and rounded base. H 17.5 cms.

Ware: Well shaped ware of medium thickness. Light in weight. Matt surface finish. Grey with orange patches.

Name: ombia (museum records)

Figure LXIX No. 311

SAM 4098 KUALUTHI Ovamboland 1923. South West Africa Expedition.

Shape: Flask-shaped pot with tall, curved everted

Figure LXIX No. 311 (continued)

neck formed with poorly-defined point of inflection, rounded rim and flattened base.
H 27.7 cms.

Ware: Well shaped, evenly finished ware. Thin-walled.

Name: ositoo (museum records)

Figure LXIX No. 312

SAM 4104 KOLONKATHI Ovamboland 1923. South West Africa Expedition.

Shape: Spherical pot with short, upright neck formed with well-defined point of inflection, flattened rim and rounded base. H 17.5 cms.

Ware: Thick, heavy weight ware. Well formed. Roughly finished.

Decoration: Fibre bound round neck.

Name: ombia (museum records)

Figure LXIX No. 313

SMM 4105 KOLONKATHI Ovamboland 1923. South West Africa Expedition.

Shape: Inverted bag-shaped pot with short, upright neck formed with poorly-defined point of inflection, slightly thickened rim and rounded base. H 14.75 cms.

Ware: Fairly thick-walled medium heavy ware. Poor firing. Well shaped.

Decoration: Band of grooved patterning below rim.

Name: ombia (museum records)

Figure LXX No. 314

COP. No number (? Mpukushu cf. No. 328) Ghanzi, Bechuanaland. Probably made about the turn of the century. Obtained from Bushman woman. 1961.

Shape: Large wide-mouthed pot with upright neck formed with poorly-defined point of inflection, flattened rim and slightly pointed base. H 30 cms.

Decoration: Rather obscure. Appears to be a band of grooved cross-hatching around raised band at mouth. Band of triangles on incised background at base of neck.

Figure LXX No. 315

SAM 9025 KUANGARI Runtu District, South West Africa, 1963. Mrs. Maree.

Shape: Wide-mouthed incurved bowl with tall straight slightly inward-sloping neck formed with well-defined point of inflection, flattened thickened rim and rounded base. H 13 cms.

Ware: Thin walled, light weight ware. Very well fired. Mottled grey, orange and black.

Decoration: Poorly executed incised and grooved design.

Figure LXX No. 316

SAM 9025 KUANGARI Runtu District, S.W.A. 1963. Mrs. Maree.

Shape: Wide-mouthed incurved bowl with tall, straight slightly inward-sloping neck formed with well-defined point of inflection, flattened thickened rim and rounded base. H 14 cms.

Ware: as No. 315

Decoration: as No. 315

Figure LXX No. 317

SAM 9025 KUANGARI Runtu District, South West Africa 1963. Mrs. Maree.

Shape: Wide-mouthed pot with tall, upright neck formed with well-defined point of inflection, flattened thickened rim and rounded base. H 12 cms.

Ware: As No. 315

Decoration: As No. 315

Figure LXXI No. 318

PAR. 54.56.6 ? DIRIKO Nganyela (Capico, Baixo, Cubango)

Shape: Inverted bag-shaped pot with tall, slightly inward-sloping neck formed with poorly-defined point of inflection, cut rim and slightly dimpled base. H 22 cms.

Decoration: Incised designs patterned with cross-hatching.

Name: indeho (museum records)

Figure LXXII No. 319

SAM 4100 KWANKWA South West Africa 1923. South West Africa Expedition.

Shape: Beaker with flattened rim and flattened base. H 15.9 cms.

Figure LXXII No. 319 (continued)

Ware: Poorly shaped ware of medium thickness and weight.

Decoration: Raised applied lumps.

Name: ositoo (museum records)

Figure LXXII No. 320

SAM 8484 KUANGARI Lupala, Okavango, South West Africa. July 1961. Ethnologist, South African Museum.

Shape: Wide-mouthed incurved bowl with upright neck formed with well-defined point of inflection, cut rim and rounded base. H 11.6 cms.

Ware: Crudely finished ware of medium thickness and weight. Very well fired. Light pinky buff with large black patches.

Decoration: Raised band of cross-hatched grooving. Stamped impressions around base of neck.

Use: For beer and sauce. Beer made first in kandimbe then put to ferment in calabash (seller - museum records)

Name: kandimbe (seller - museum records)

Figure LXXII No. 321

SAM 4099 KWANKWA Ovamboland 1923. South West Africa Expedition.

Shape: Flask-shaped pot with tall, curved, everted neck formed with poorly defined point of inflection, slightly thickened rim and pointed base. H 22.5 cms.

Ware: Light weight ware of medium thickness. Medium firing. Roughly finished.

Decoration: Applied lumps around base of neck. Grooved line design. No colour or burnish.

Name: ositoo (museum records)

Figure LXXII No. 322

SAM 8486 KUANGARI Lupala, Okavango, South West Africa. July 1961. Ethnologist, South African Museum.

Shape: Spherical pot with tall, straight upright neck formed with well defined point of inflection, cut rim and rounded base. H 19.4 cms.

Ware: Crudely finished ware of medium thickness and weight. Cracked in firing. Light pinky buff with black patches. Section across biscuit shows clay to be black in centre.

Figure LXXII No. 322 (continued)

Decoration: Grooved cross-hatching on raised band around mouth. Stamped impressions at base of neck.

Use: beer or water pot (potter - museum records)

Name: kavaza (potter - museum records)

Figure LXXII No. 323

SAM 9006 DIRIKO Ngumbe, Okavango, South West Africa 1963 F. Taylor Expedition.

Shape: Wide-mouthed pot with everted neck formed with poorly-defined point of inflection, flattened rim and rounded base. H 15.8 cms.

Ware: Roughly made, thick ware. Blackened by use.

Decoration: Two raised bands patterned with grooved cross-hatching.

Use: for cooking meat (seller - museum records)

Name: kanjungu (seller - museum records)

Figure LXXII No. 324

SAM 9007 DIRIKO Near Ondongo, Omavamba Omatako, Okavango, South West Africa. 1963 F. Taylor Expedition.

Shape: Pot with straight, upright neck formed with well-defined point of inflection, cut rim and slightly pointed base, H 33 cms.

Ware: Smooth, evenly formed ware of medium thickness and weight.

Decoration: Two raised bands patterned with grooved cross-hatching on neck. Second series of diagonals stressed. Light hatching inside neck.

Use: bought when cracked; being used as store for tobacco seeds.

Name: kanjungu (seller - museum records)

Figure LXXIII No. 325

SAM 5654 MPUKUSHU Andara, Okavango, South West Africa. 1936 Father Frolich.

Shape: Wide-mouthed pot with tall, curved, upright neck formed with poorly-defined point of inflection, cut rim and almost pointed base. H 28.7 cms.

Figure LXXIII No. 325 (continued)

Ware: Thick walled heavy ware. Very well fired.
Good smooth finish. Blackened by use.
Decoration: Band of grooved decoration on neck.
Name: kamjungu (museum records)

Figure LXXIII No. 326

SAM 5653 MPUKUSHU Andara, Okavango, South West Africa. 1936 Father Frolich.

Shape: Spherical bowl with short, everted neck formed with well-defined point of inflection, rounded rim on tapered wall and rounded base. H 14.4 cms.

Ware: Medium thick walled ware. Fairly well fired. Light buff with smokey patches. Smooth finish.

Decoration: Pattern of red ochre on buff background.

Use: relish pot (museum records)

Name: kamjungu (museum records)

Figure LXXIII No. 327

SAM 5653 MPUKUSHU Andara, Okavango, South West Africa. 1936 Father Frolich.

Shape: Pot with short, straight everted neck formed with well-defined point of inflection, cut rim on tapered wall and pointed base. H 25.5 cms.

Ware: Well formed pottery of medium thickness and weight. Well fired. Burnished surface.

Decoration: Red ochre designs on buff background. Thong around neck.

Use: for beer or water (museum records)

Name: kamjungu (museum records)

Figure LXXIV No. 328

SAM 5654 MPUKUSHU Andara, Okavango, South West Africa 1936. Father Frolich.

Shape: Large wide-mouthed pot with tall, curved everted neck formed with poorly-defined point of inflection, cut rim and pointed base. H 41 cms.

Ware: Thick walled, heavy ware. Well fired.

Decoration: Raised band decorated with cross-hatched grooving around the mouth. Wide band incised hatching around base of neck.

Name: kamjungu (museum records)

Figure LXXV No. 329

HAM. 24.76.11 HERERO

Shape: Pot with cut rim and rounded base. Four vertically pierced applied lugs, joined by slight ridge. H 23.5 cms.

Figure LXXV No. 330

COP. G.1321 HERERO

Shape: Barrel-shaped pot with thickened rim and rounded base. H 20 cms.

Decoration: Red ochre applied around mouth. Body blackened by use.

Figure LXXV No. 331

SAM 8639 HINBA Ehombo Mountains, Kaokoveld, South West Africa. 1962 Mrs. Weseman.

Shape: Wide-mouthed spherical bowl with short, straight everted neck formed with well-defined point of inflection, cut rim and rounded base. H 17.5 cms.

Ware: Beautifully shaped, medium thick ware. Very well fired. Brick red inside, gun-metal grey outside with small area of brick-red. Matt finish.

Decoration: Stamped design made with the end of a grass stalk.

Cape Ngweni

All Mounds

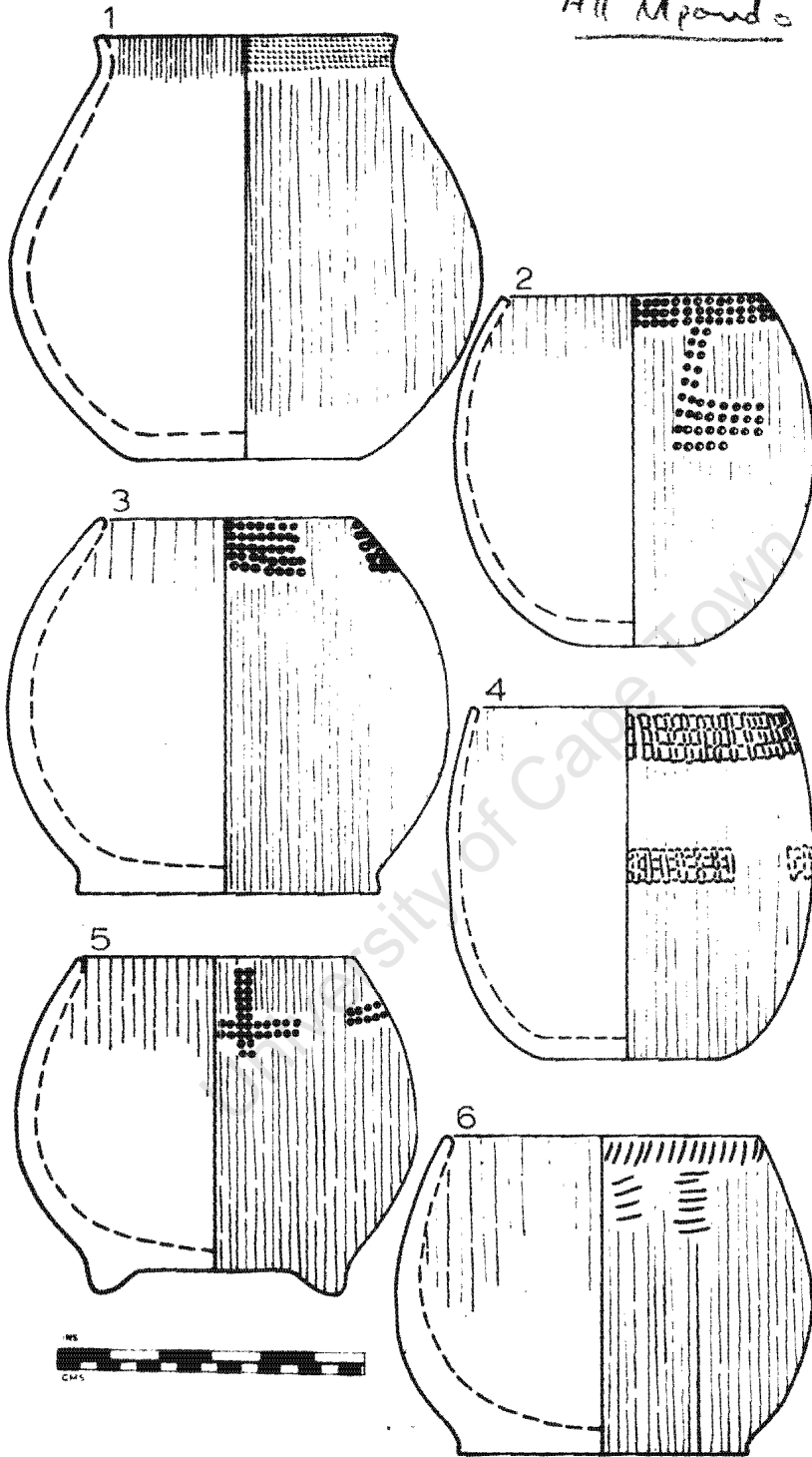

Figure 1

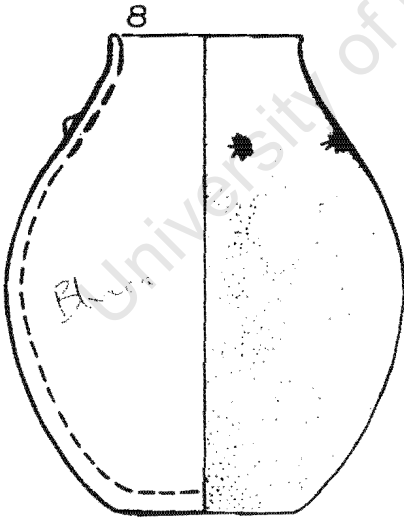
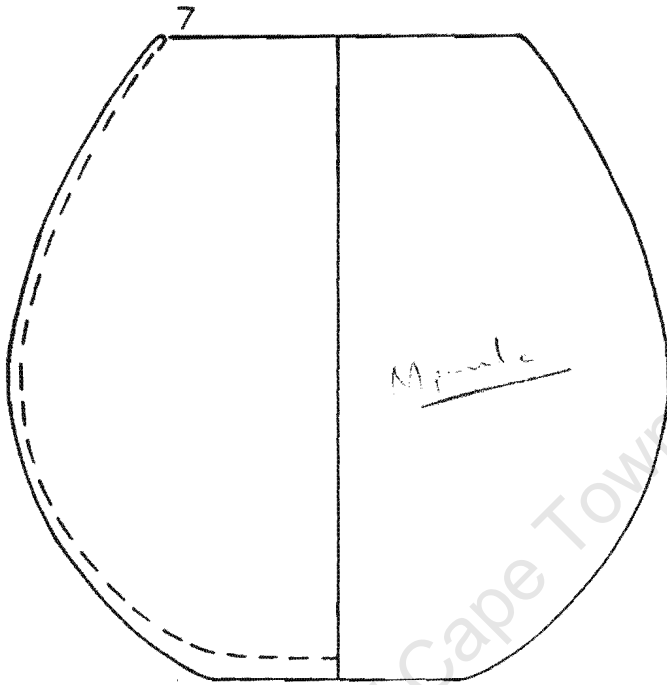

Figure II

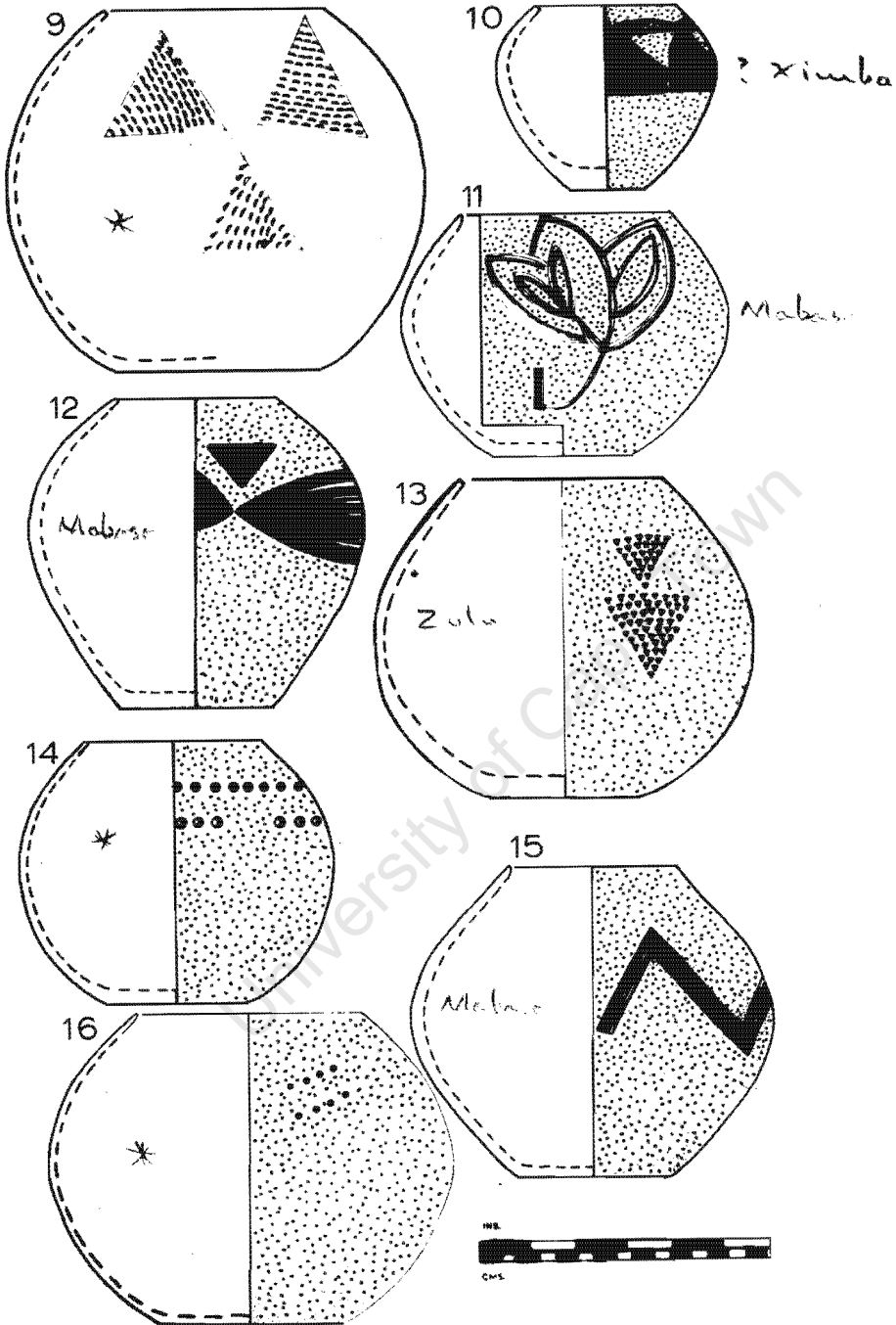

Figure III

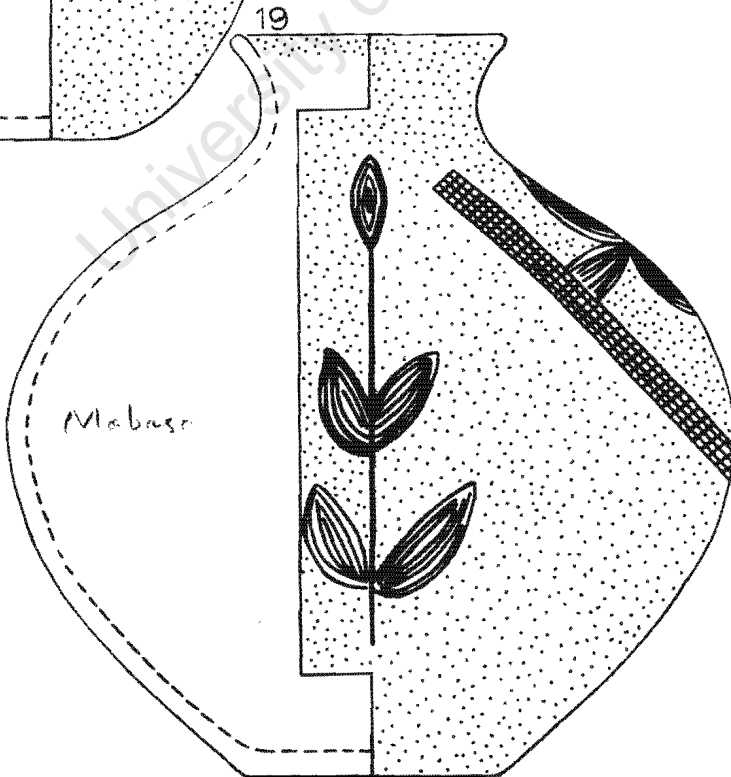
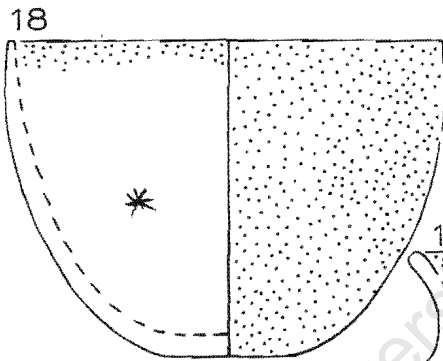
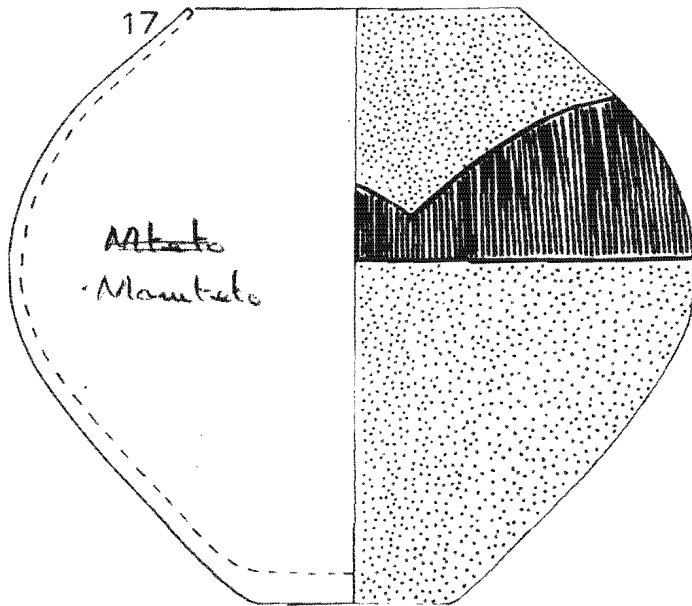

Figure IV

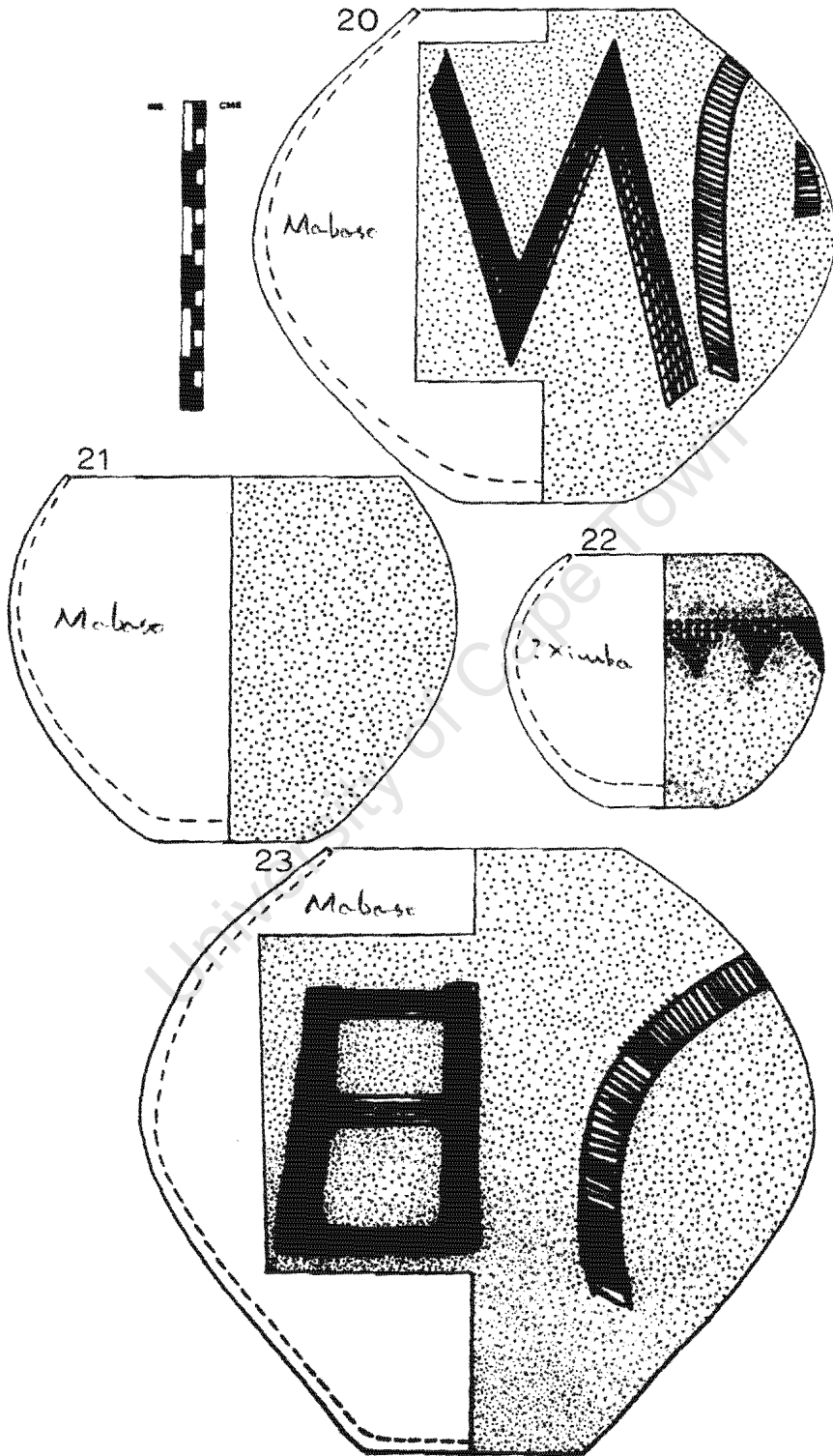

Figure V

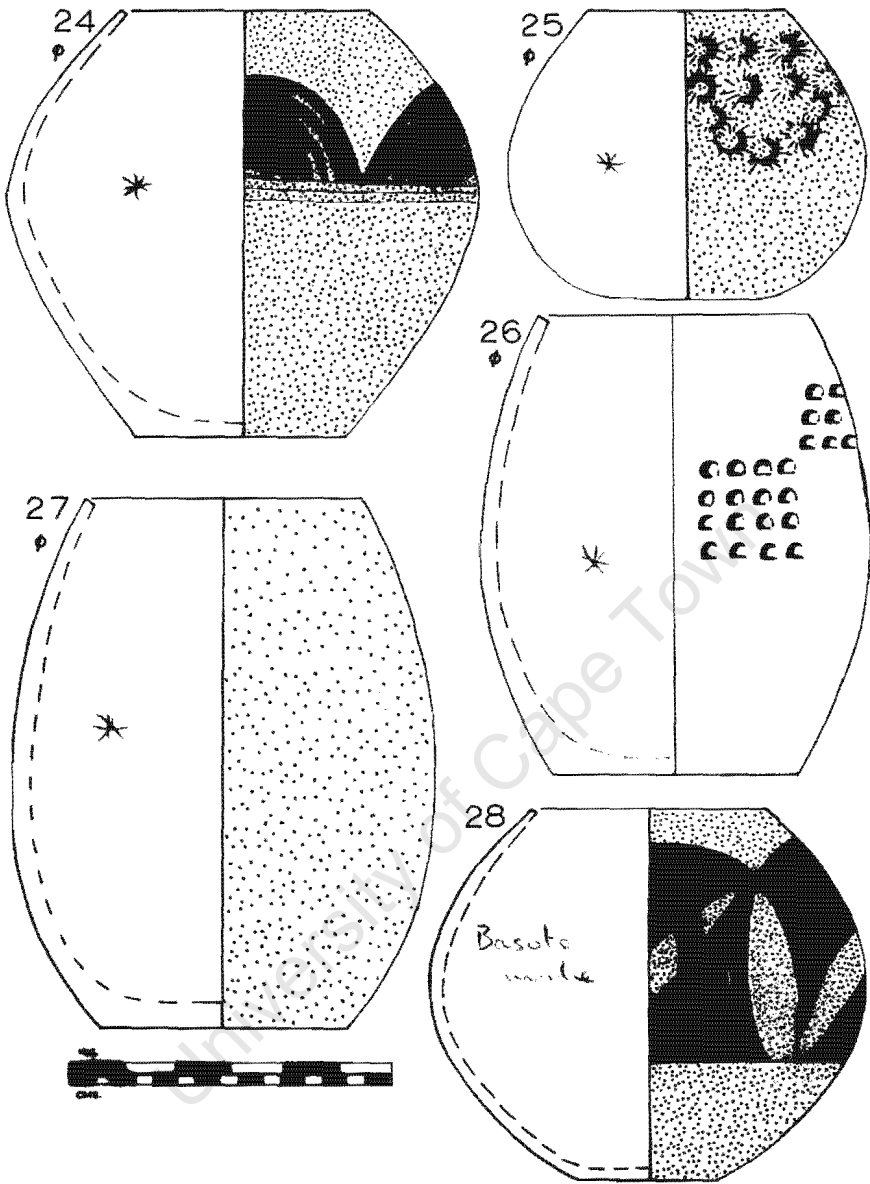

Figure VI

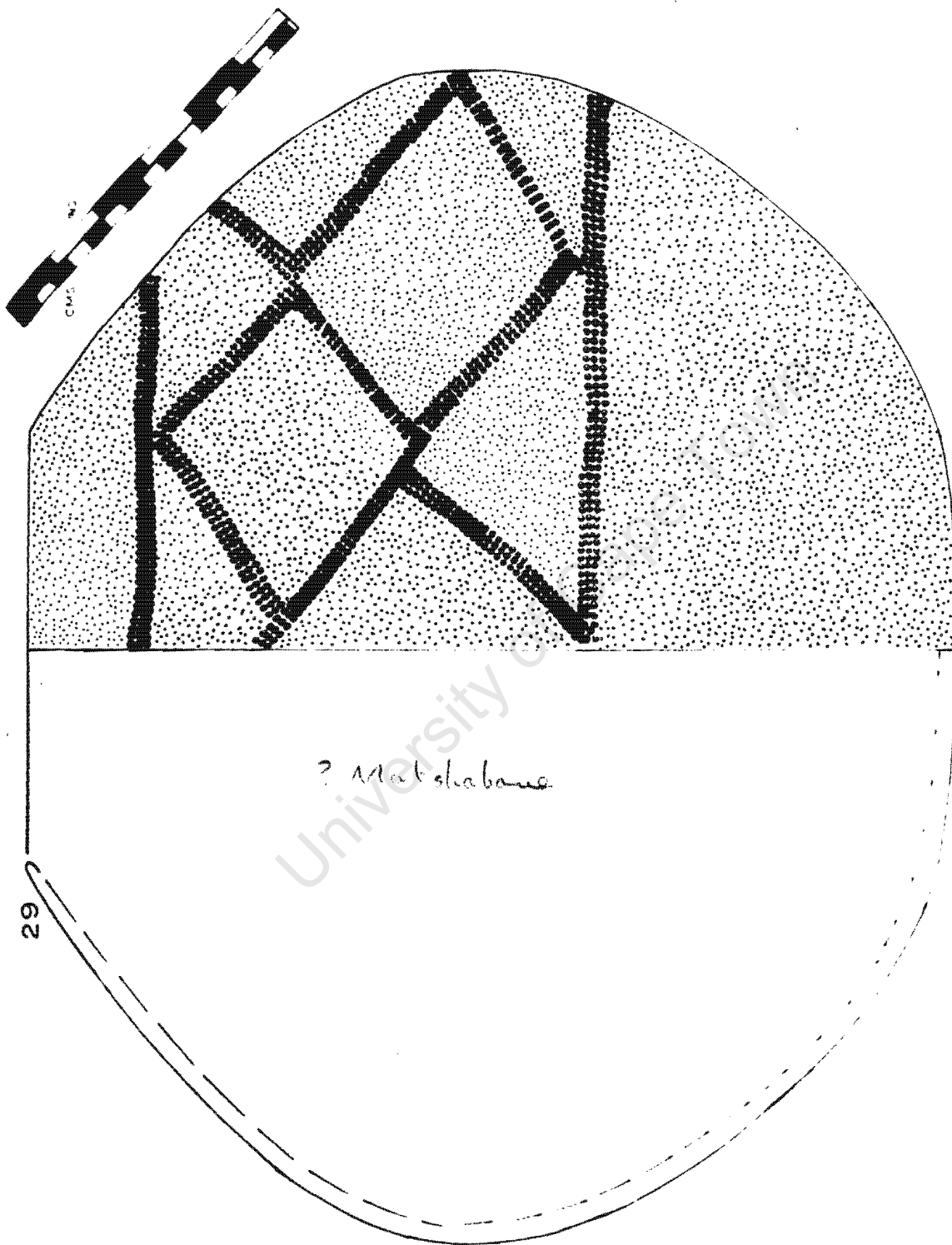

Figure VII

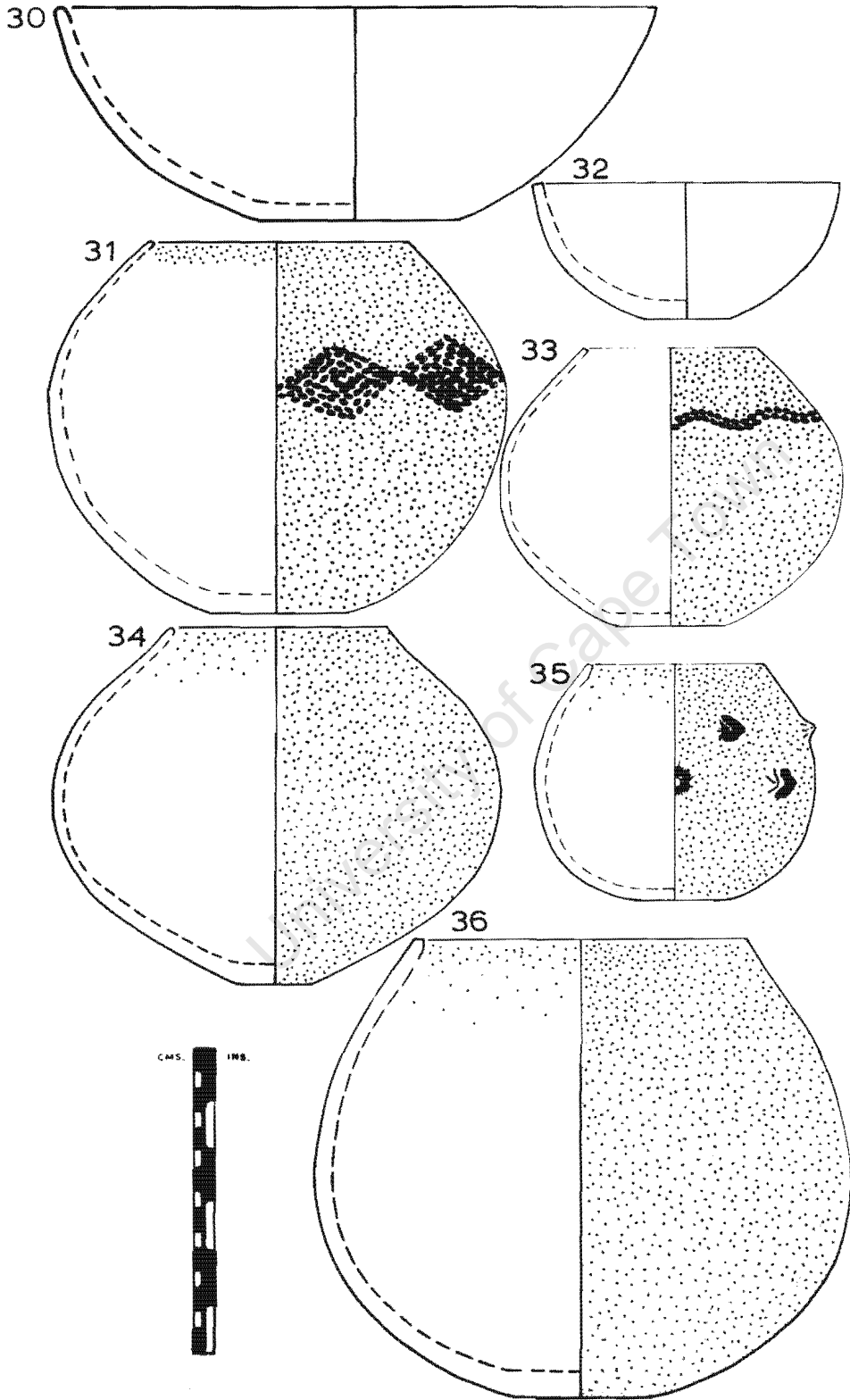

Figure VIII

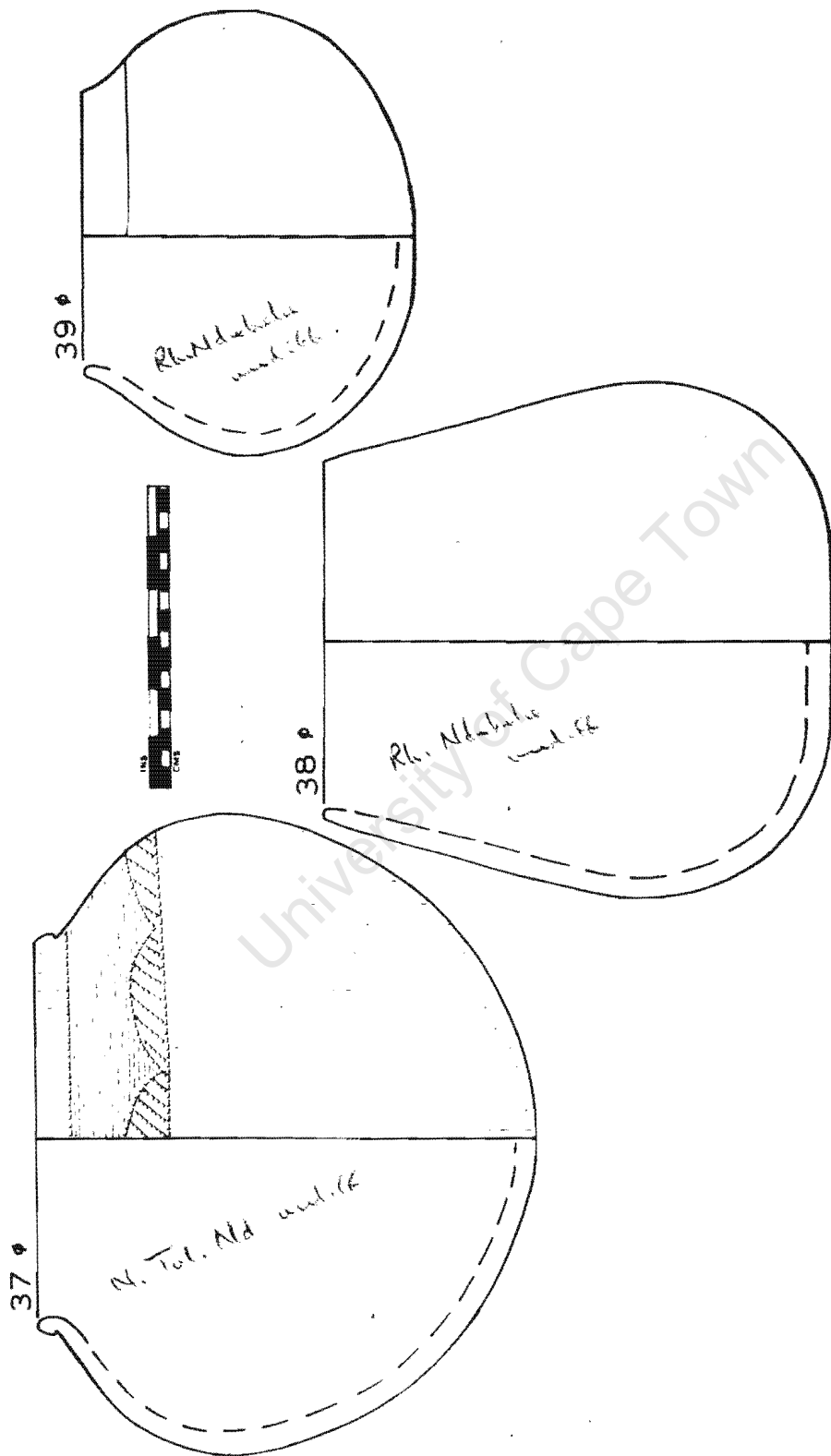

Figure IX

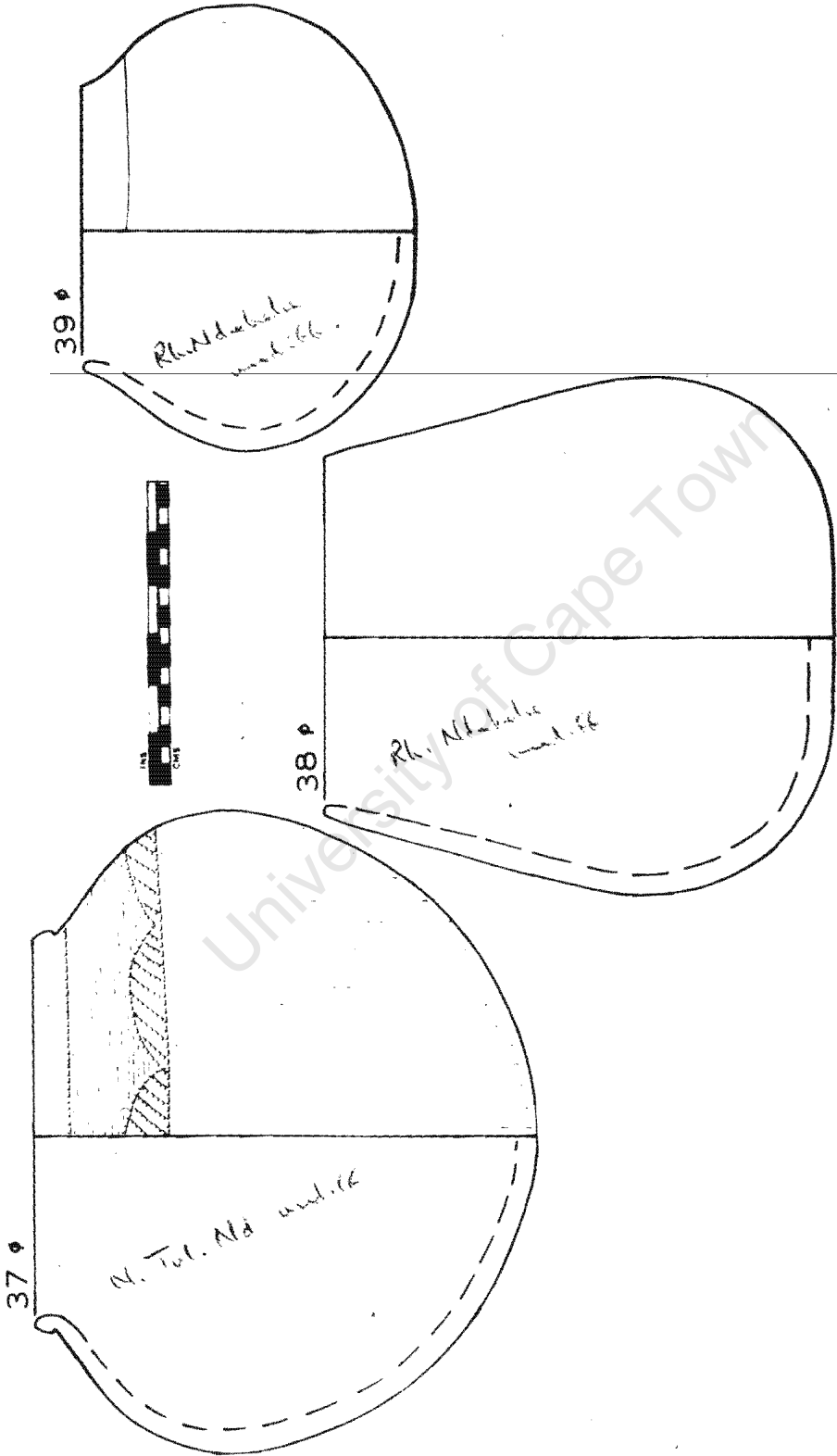

Figure IX

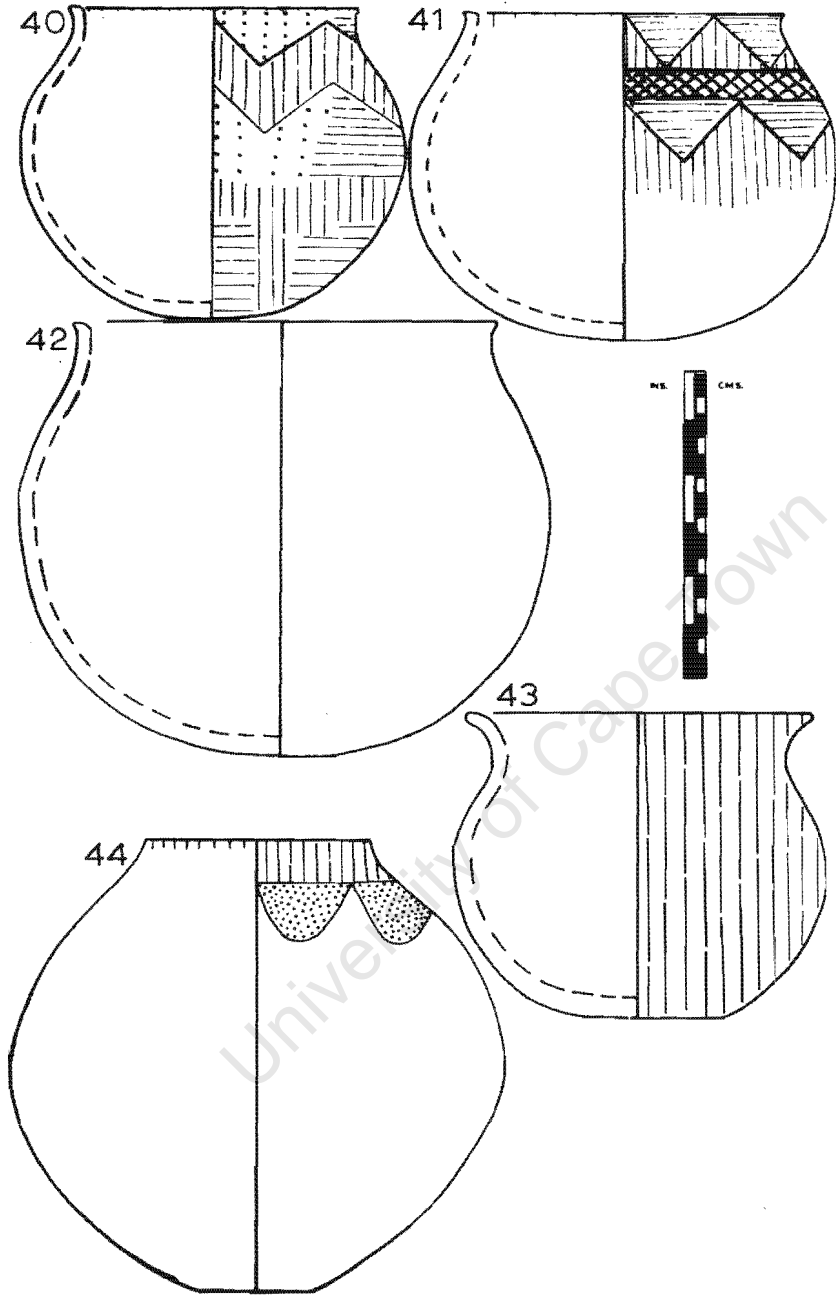

Figure X

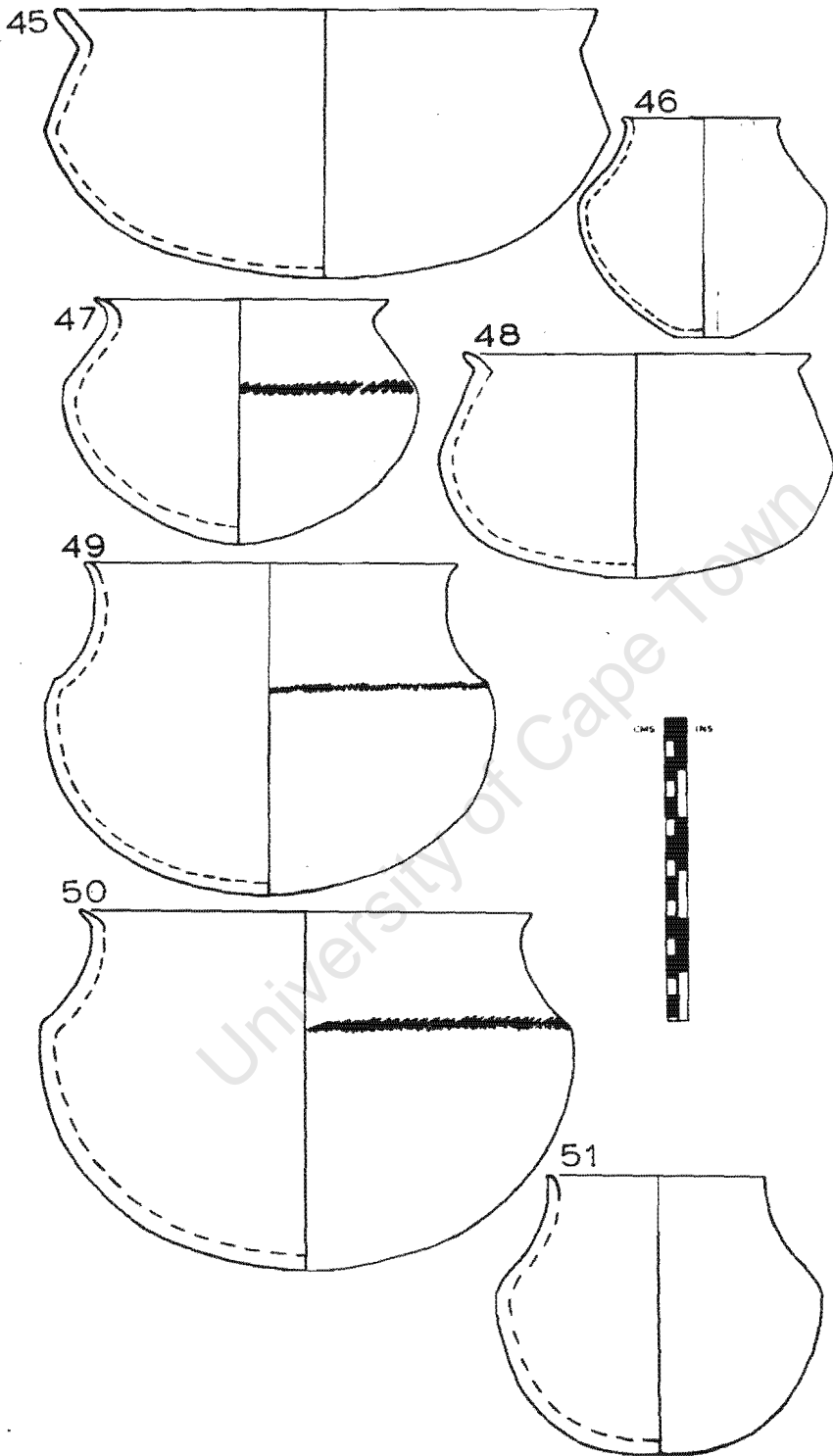

Figure XI

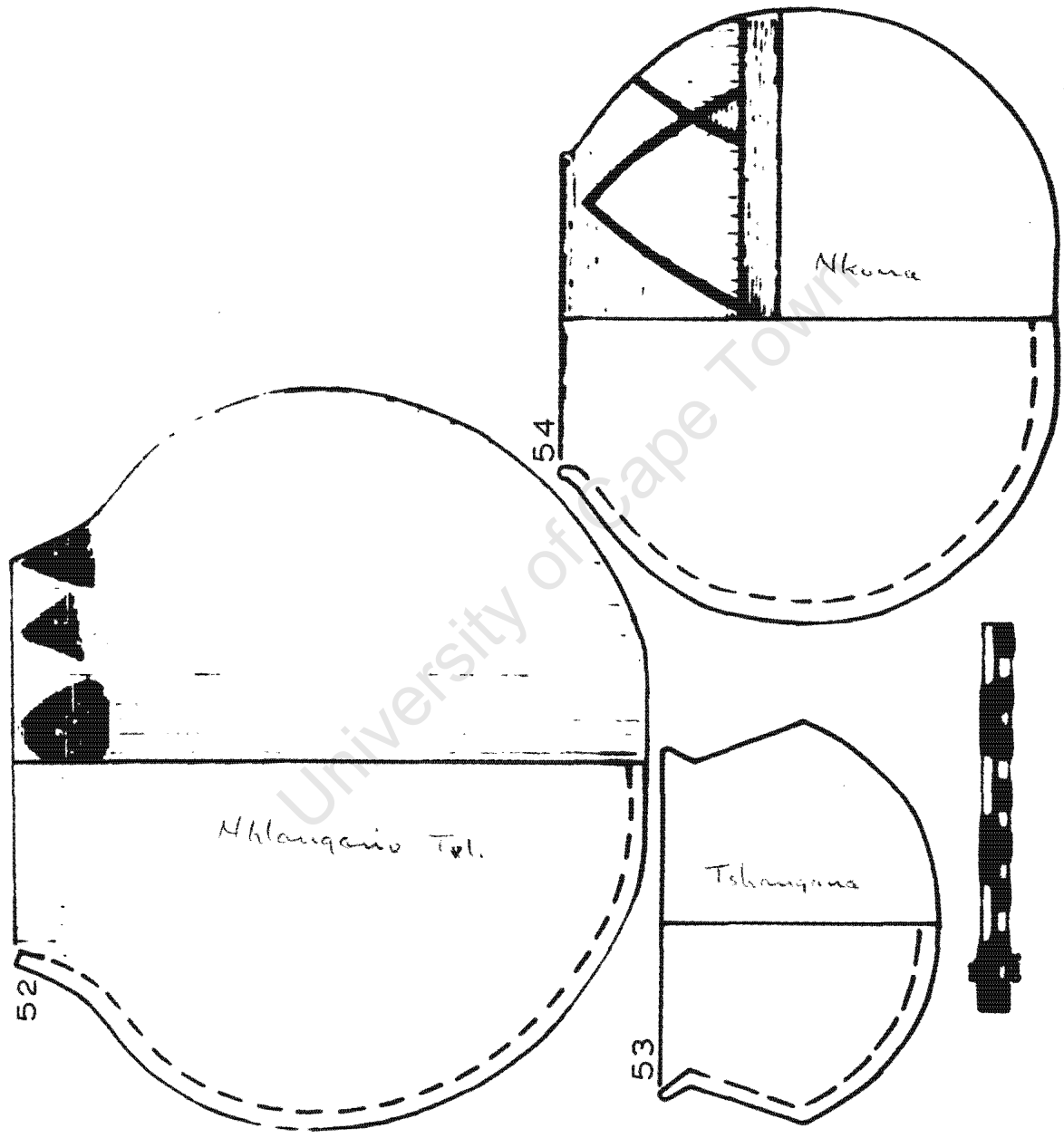

Figure XII

All Hlangwe

TSONGA

N. Tsonga

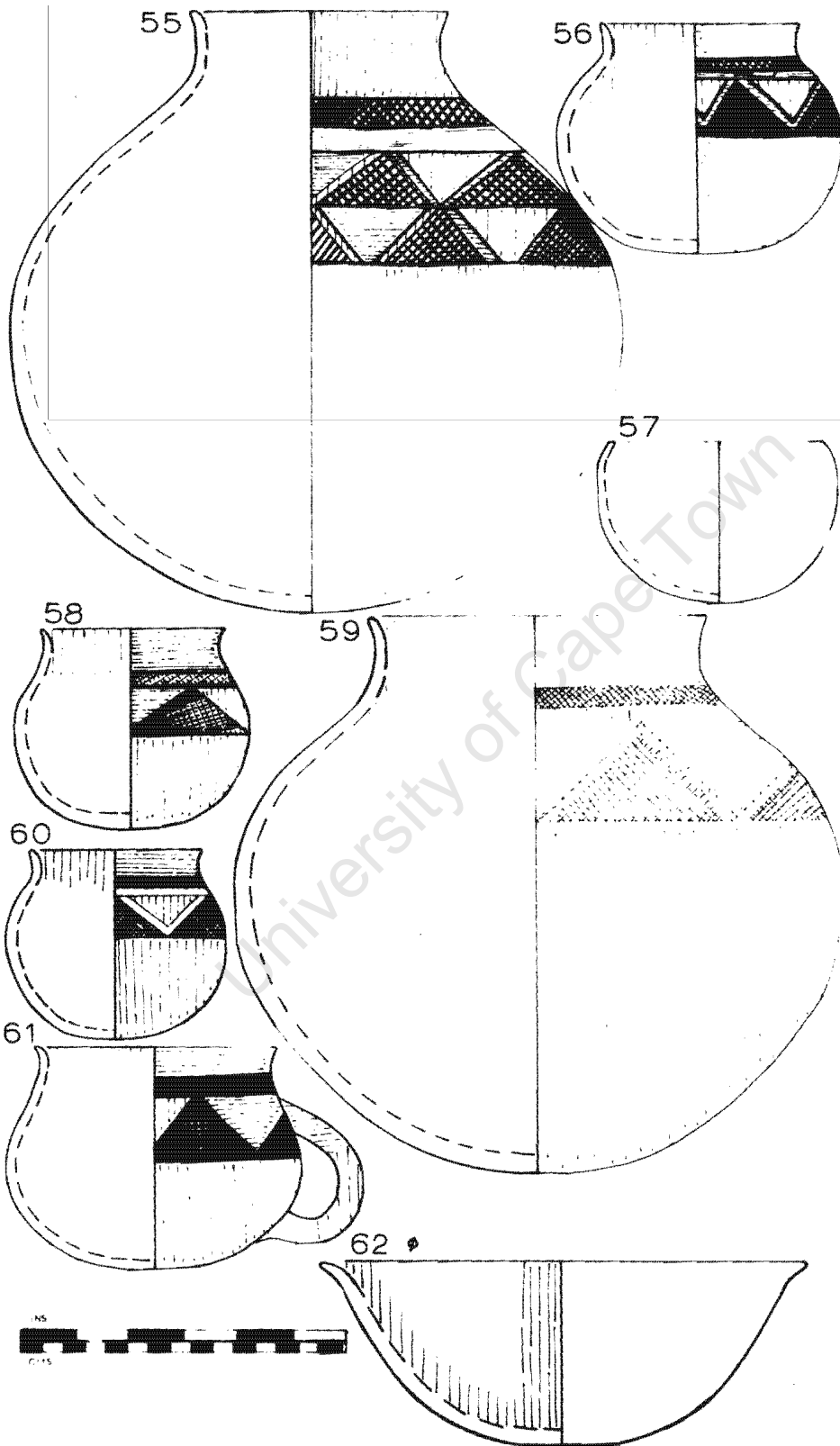

Figure XIII

711 Tswa

TSONGA

N. Tsonga

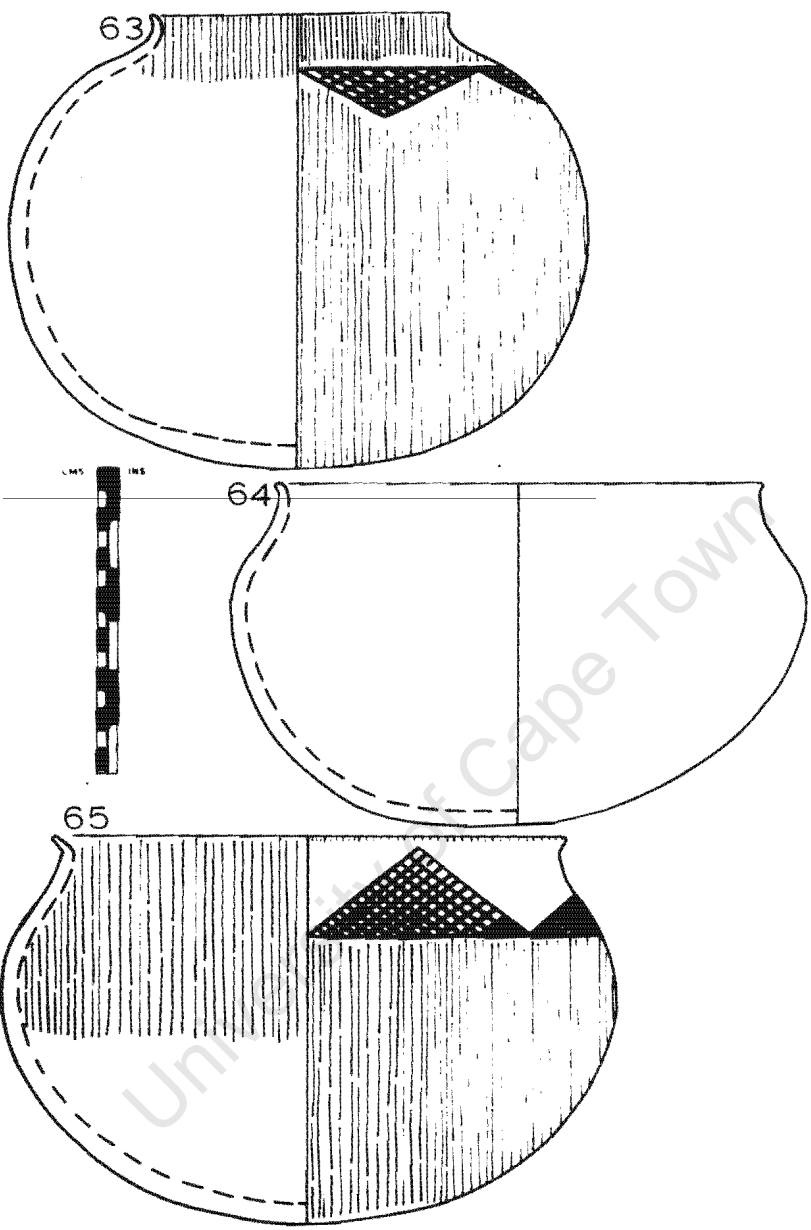

Figure XIV

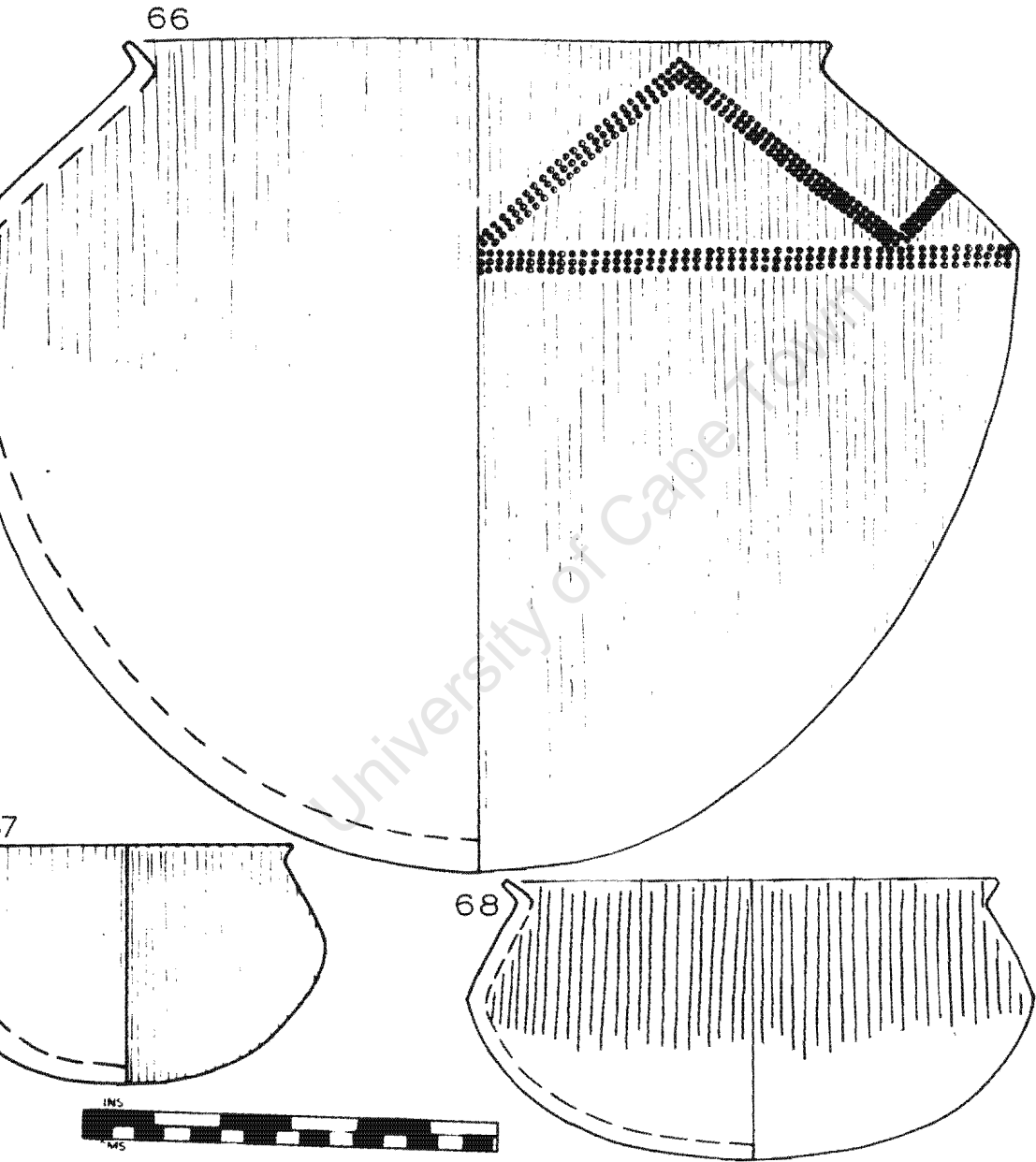

Figure XV

Basuto

All undressed.

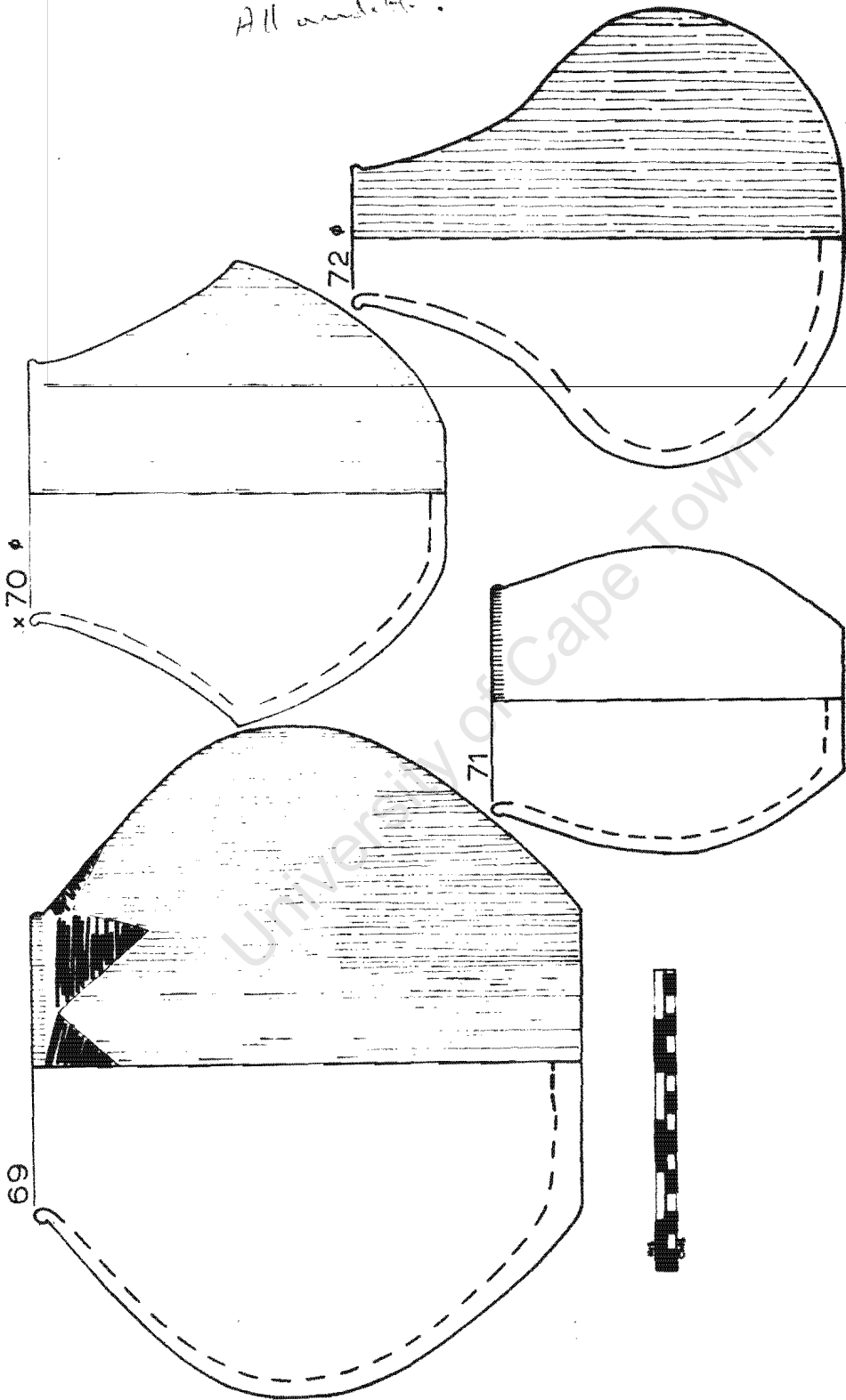

Figure XVI

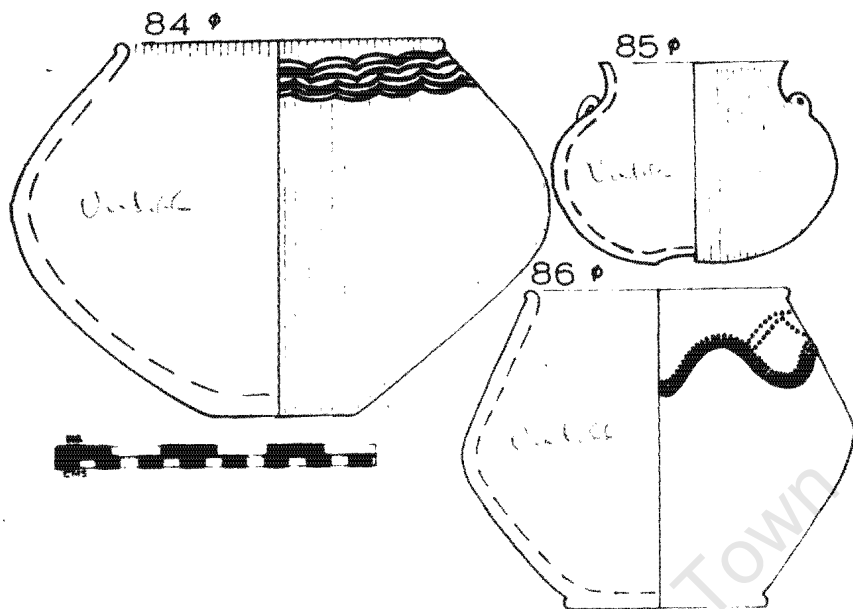

Figure XVIII

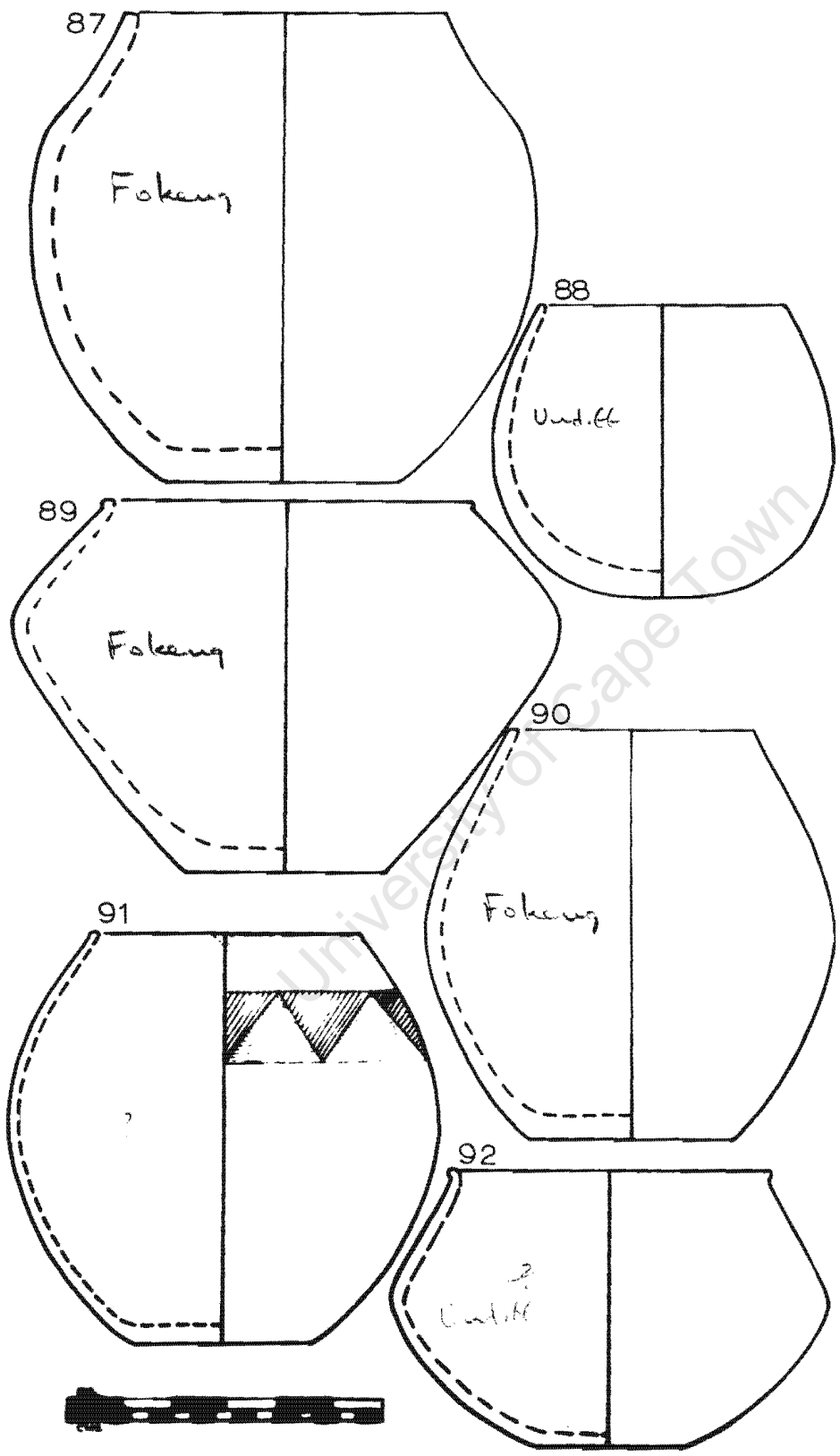

Figure XIX

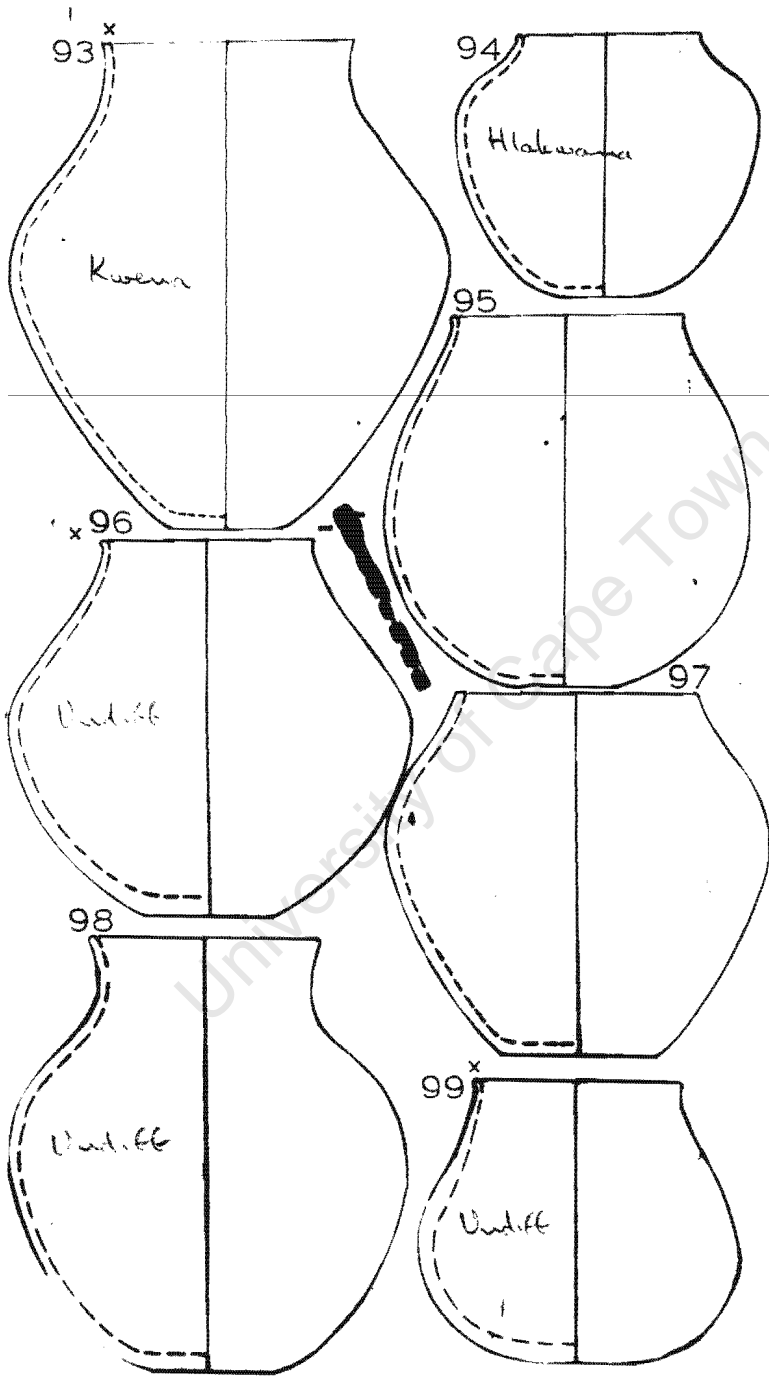

Figure XX

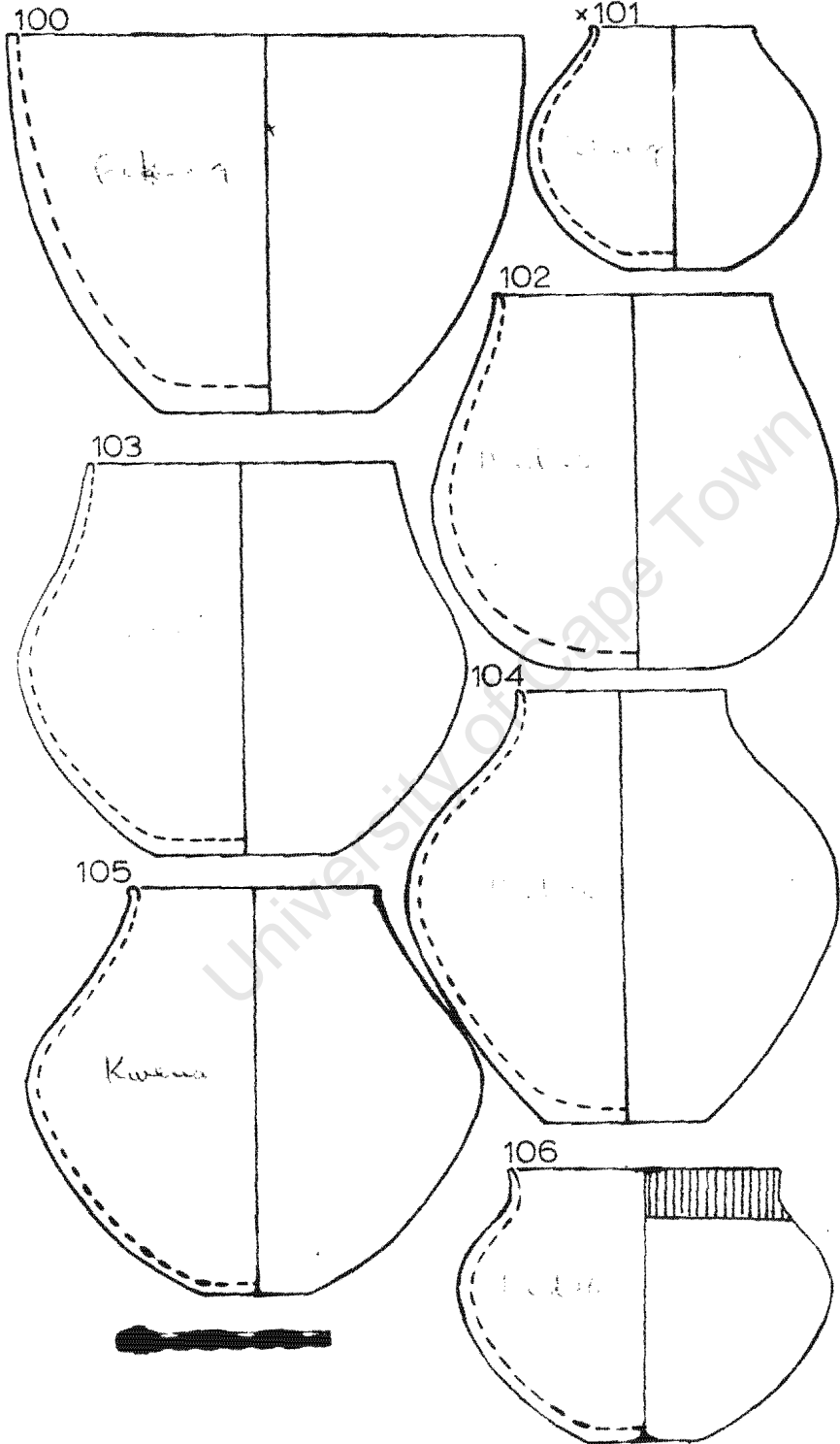

Figure XXI

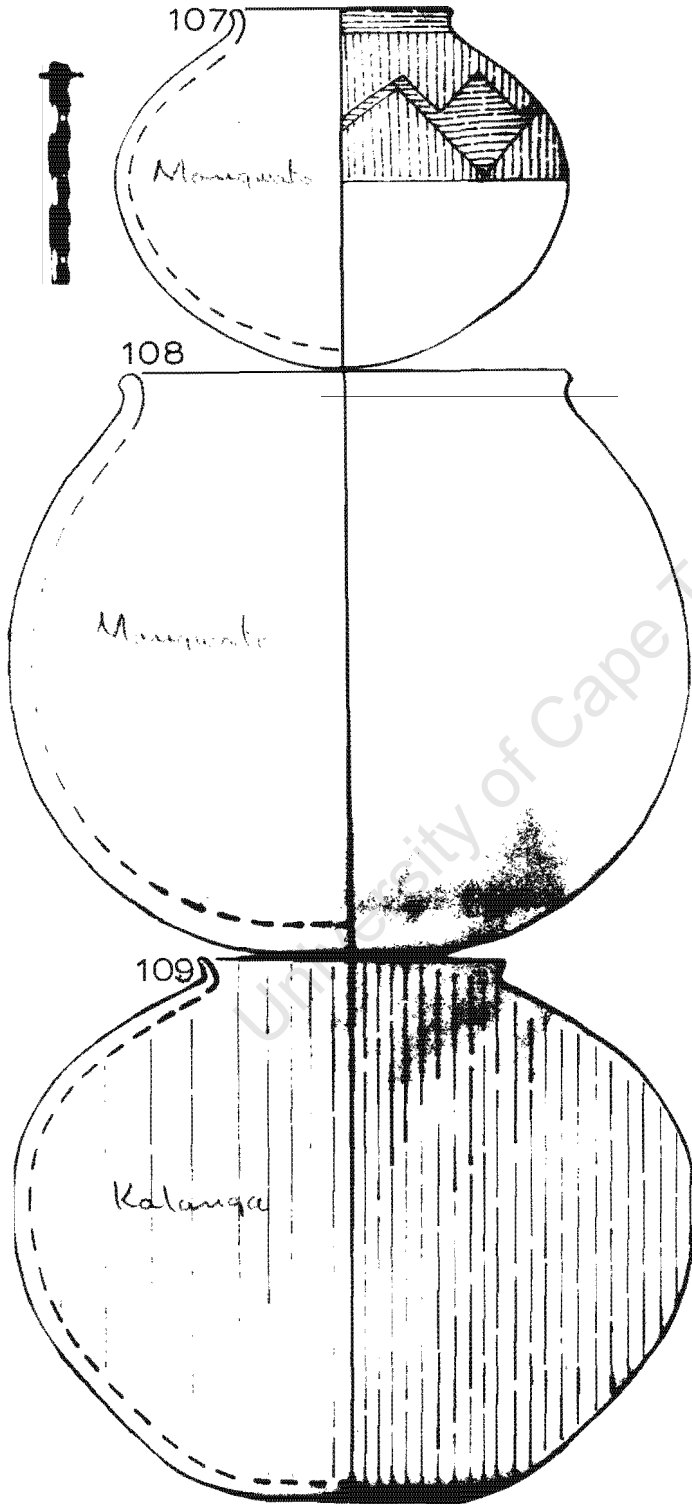

Figure XXII

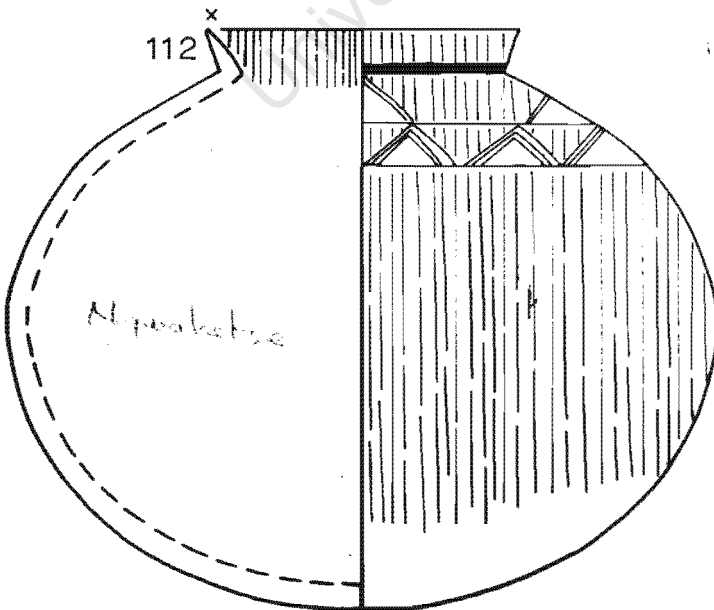
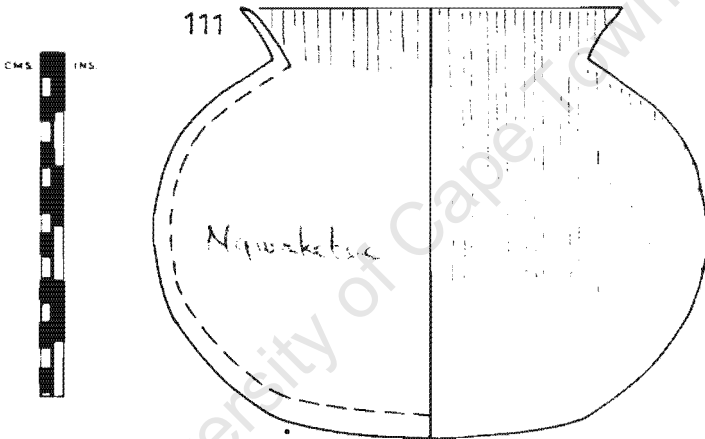
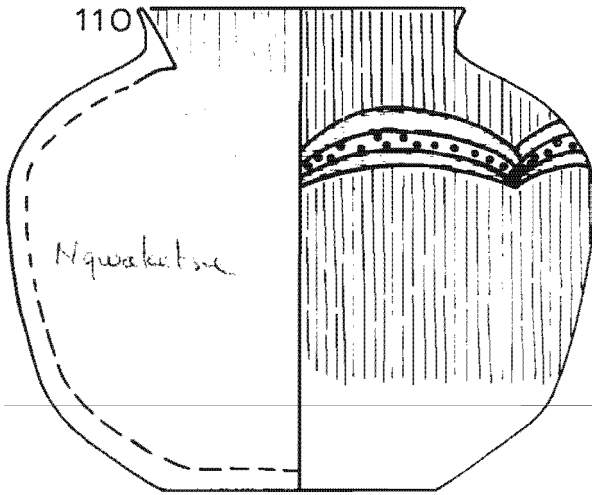

Figure XXIII

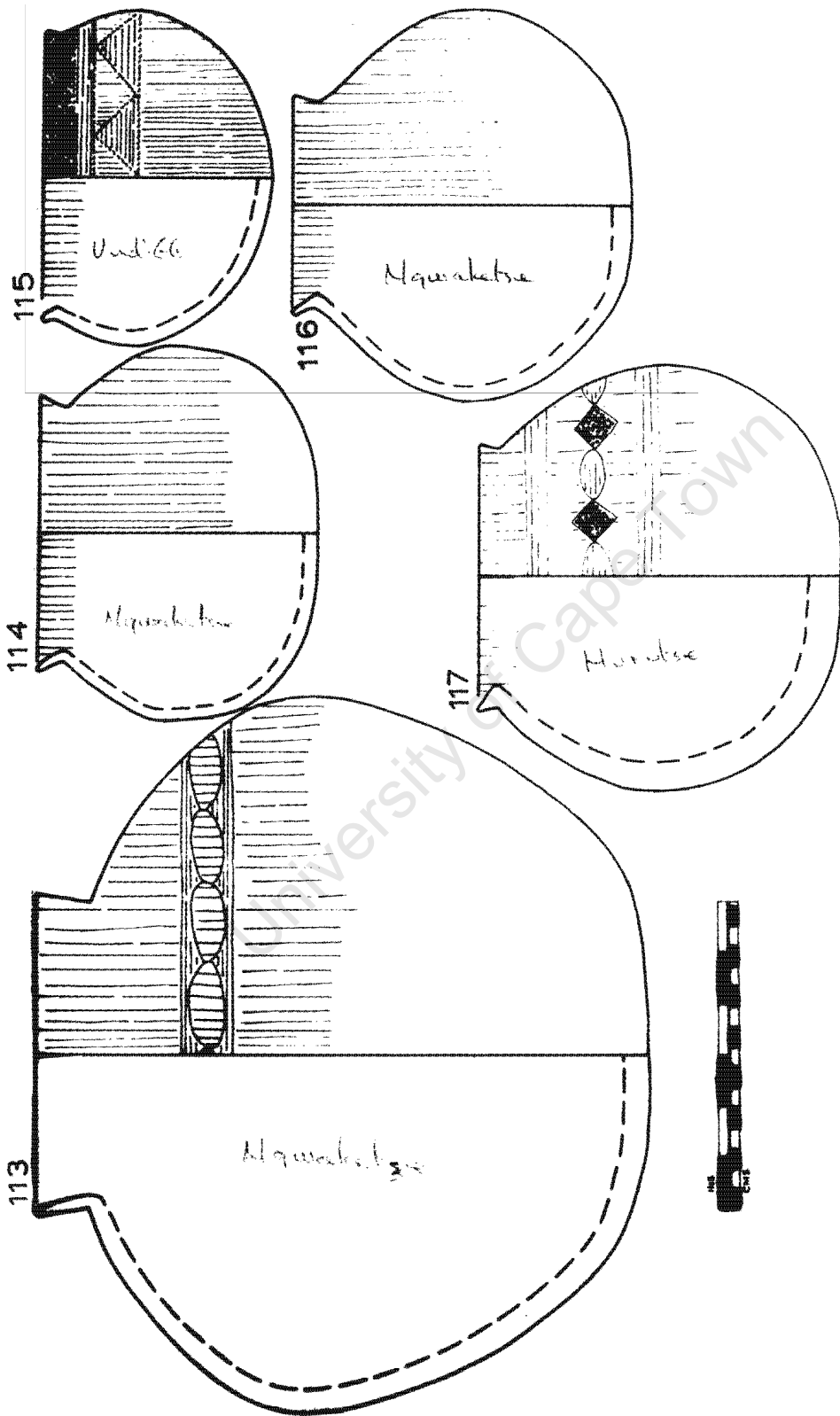

Figure XXIV

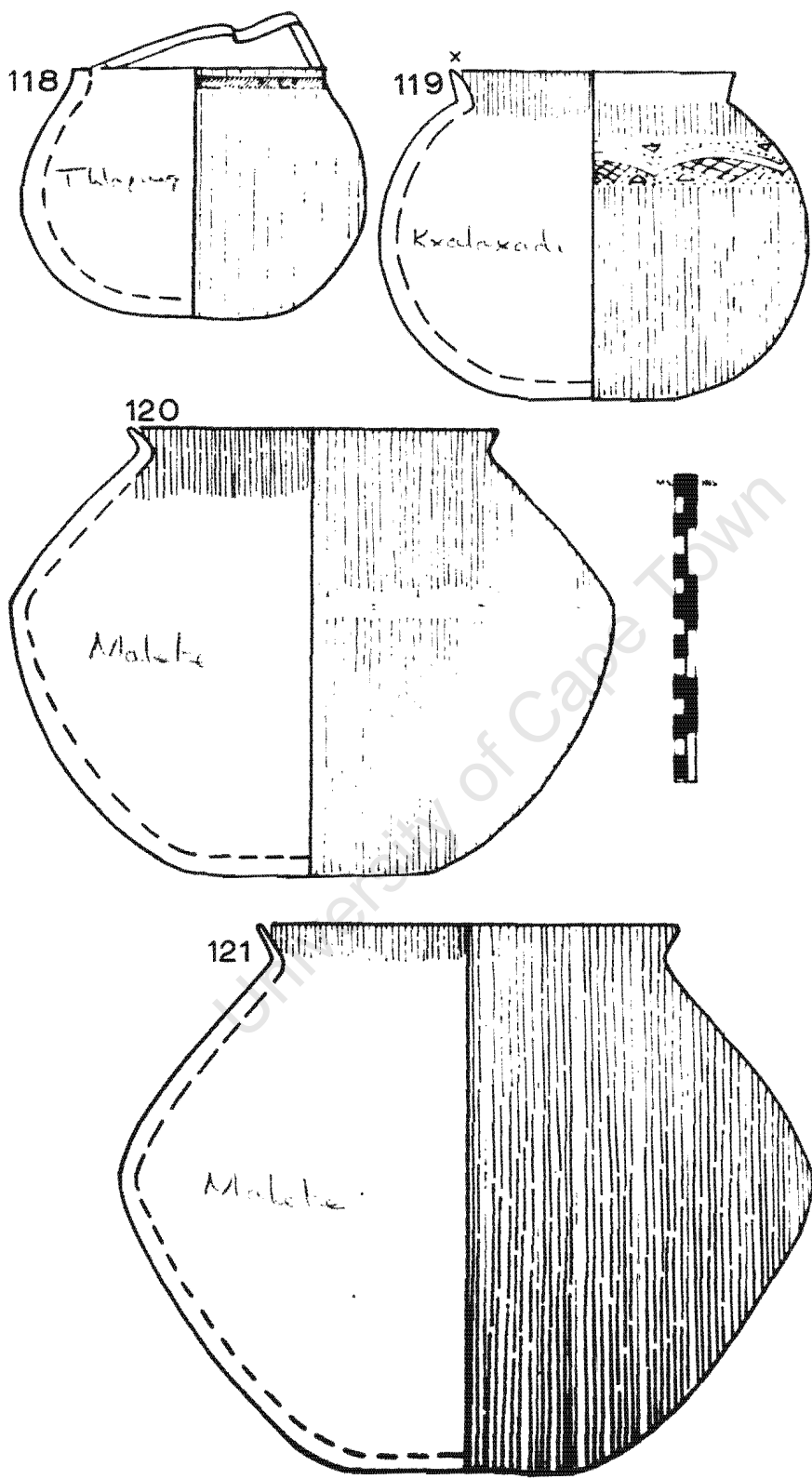

Figure XXV

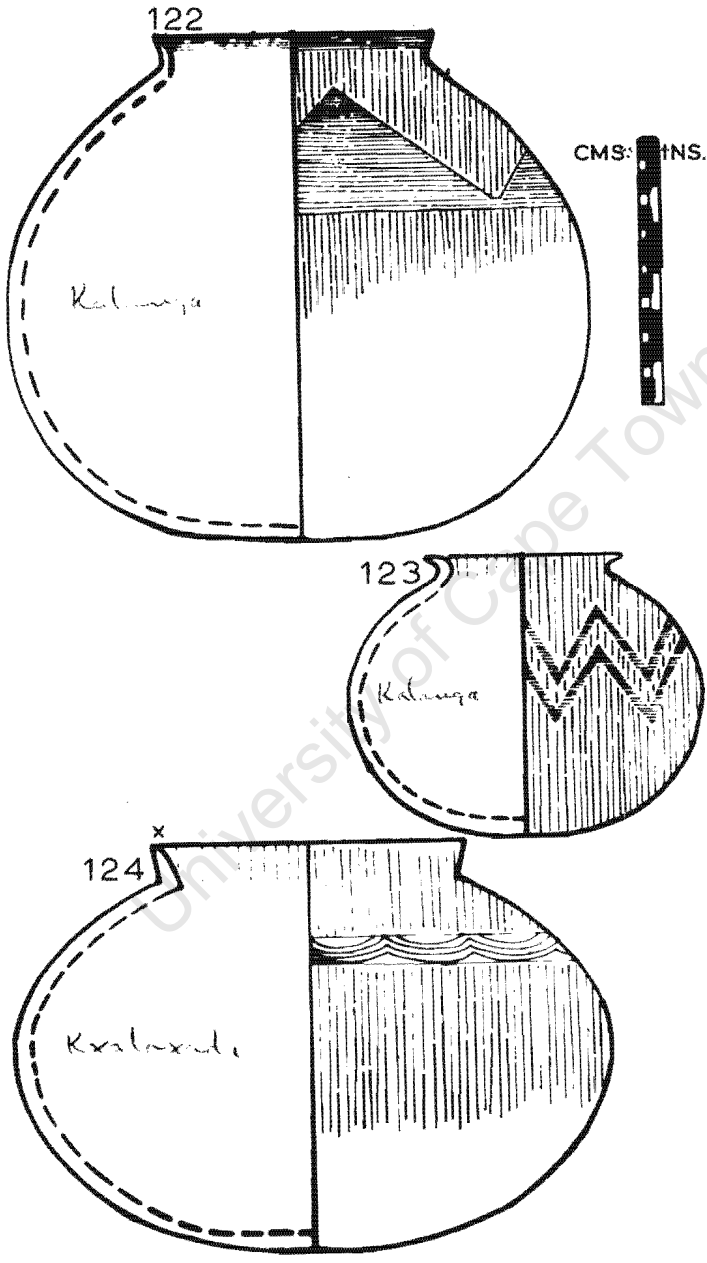

Figure XXVI

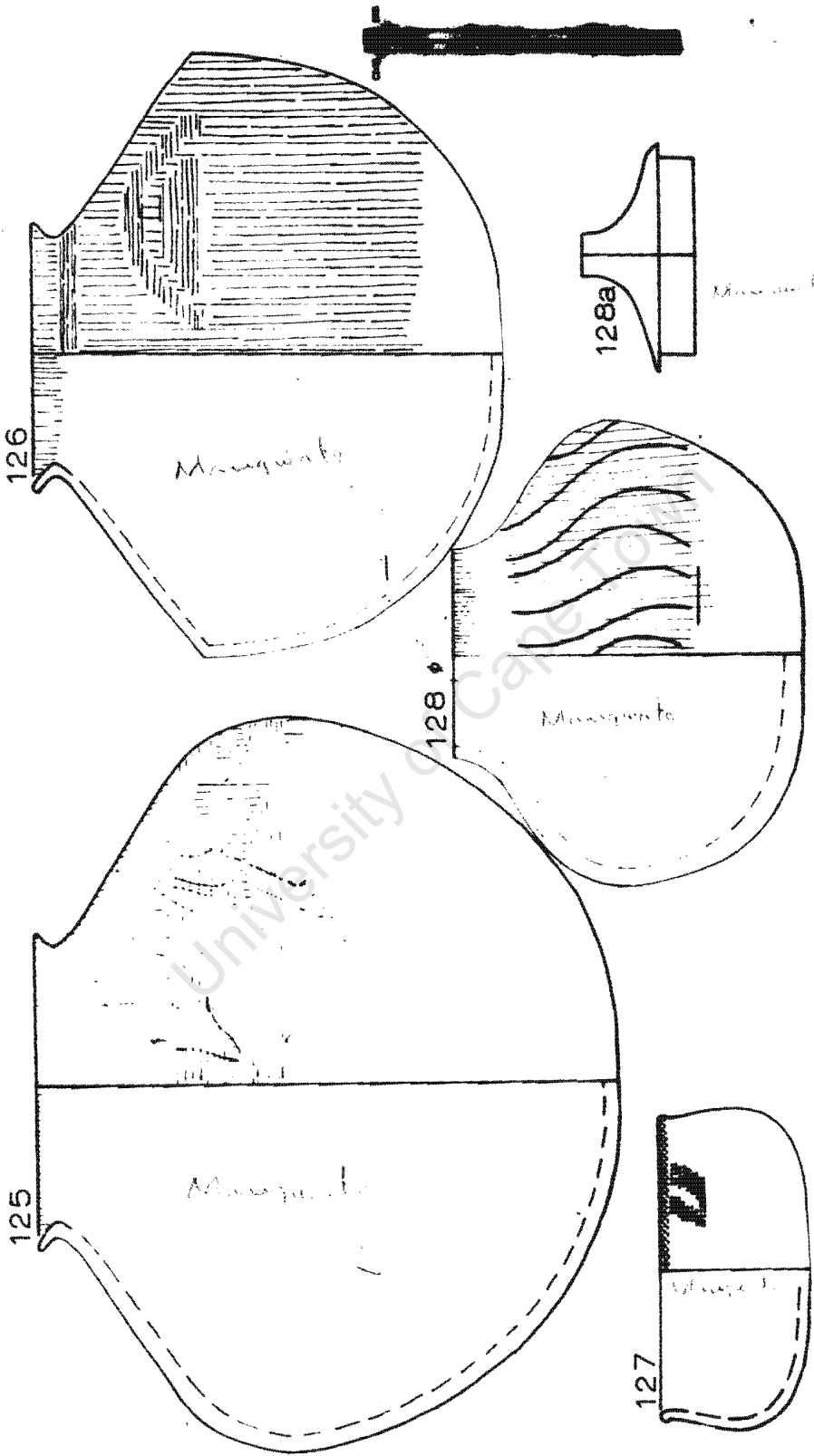

Figure XXVII

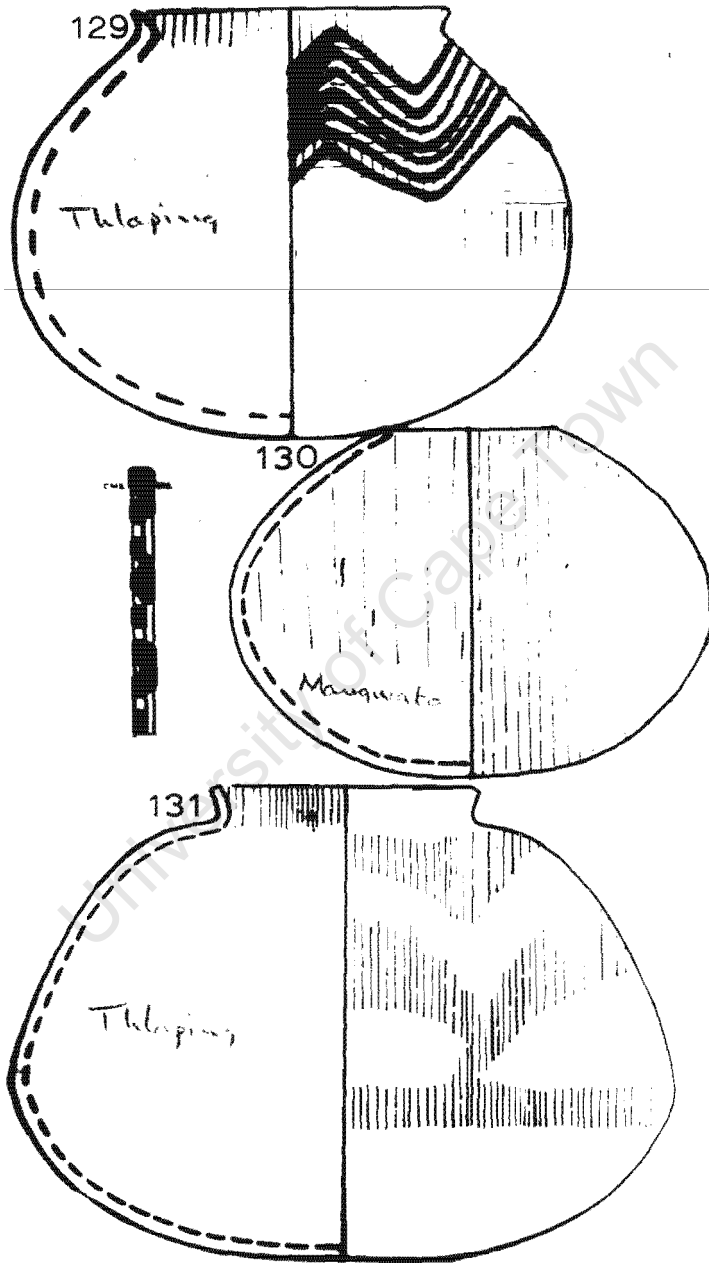

Figure XXVIII

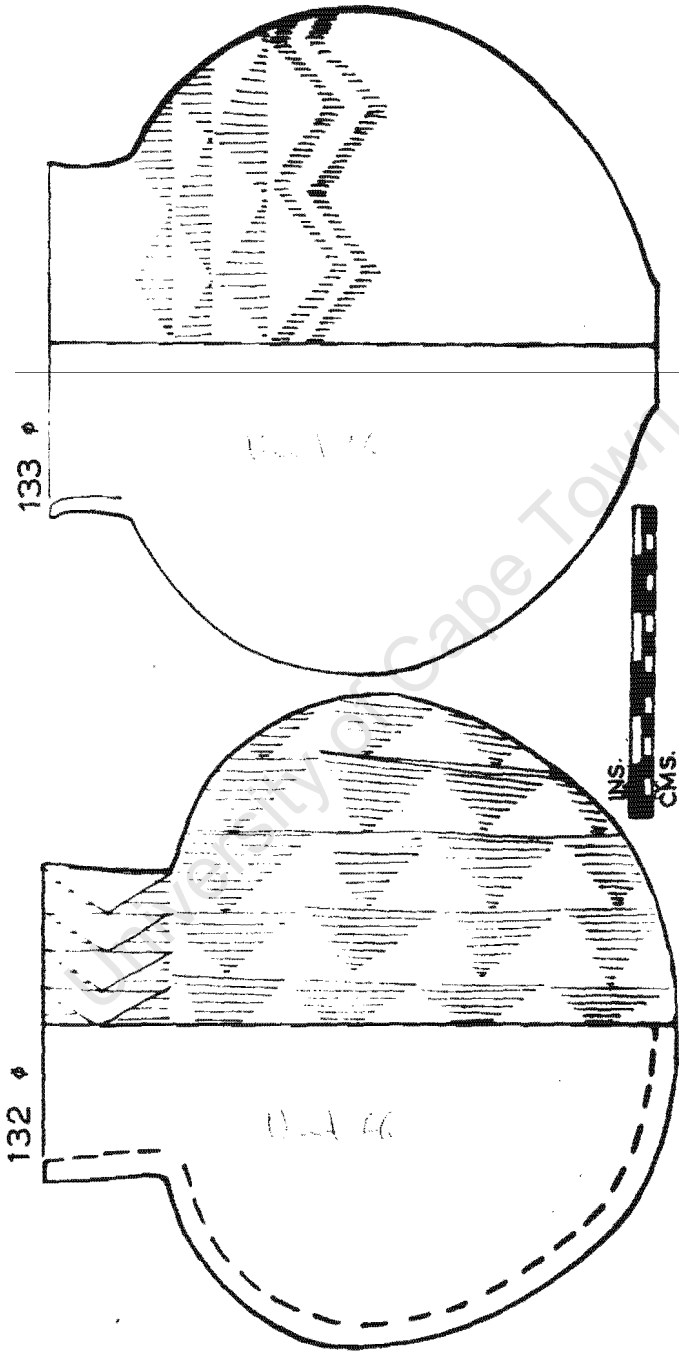

Figure XXIX

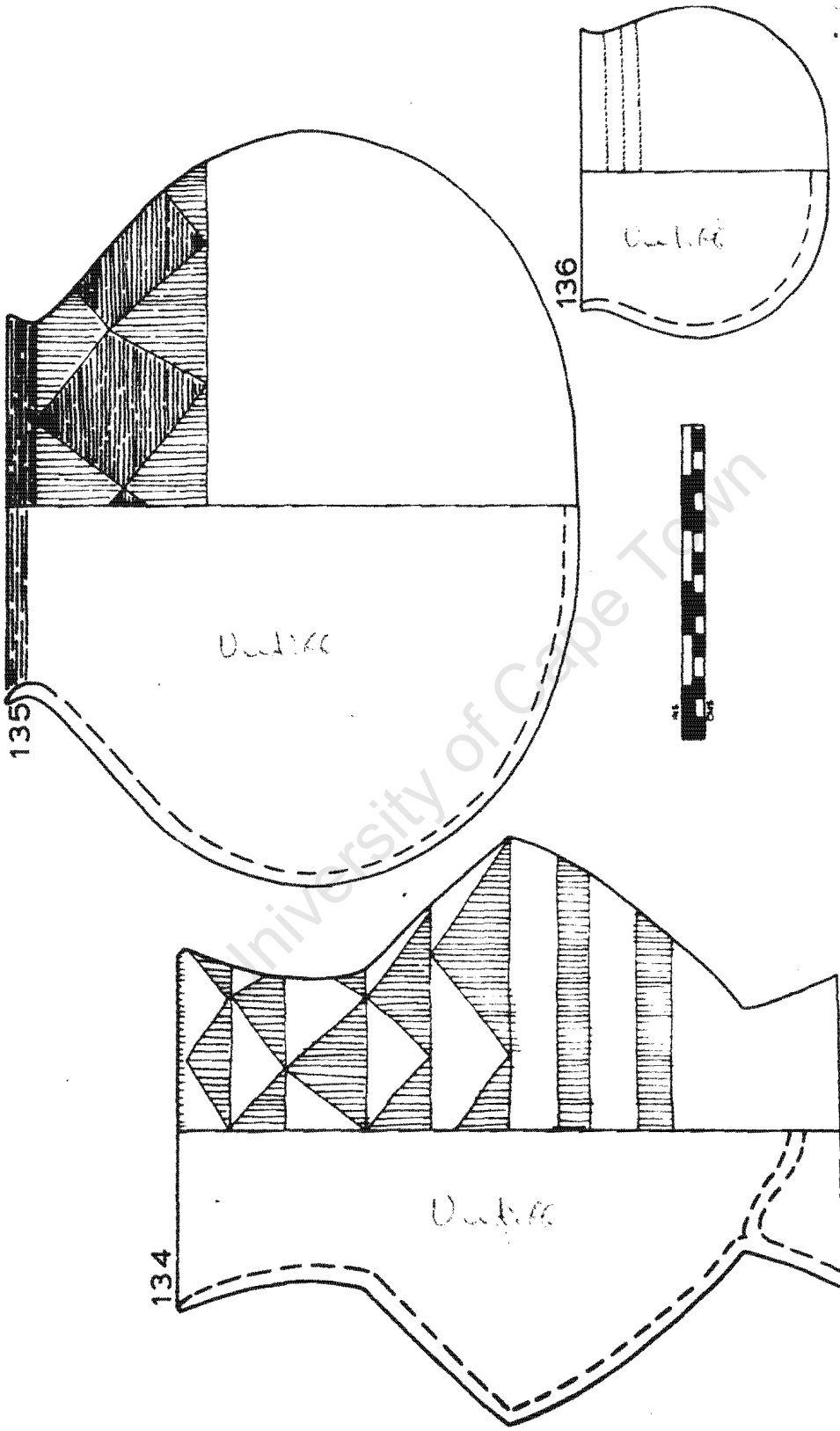

Figure XXX

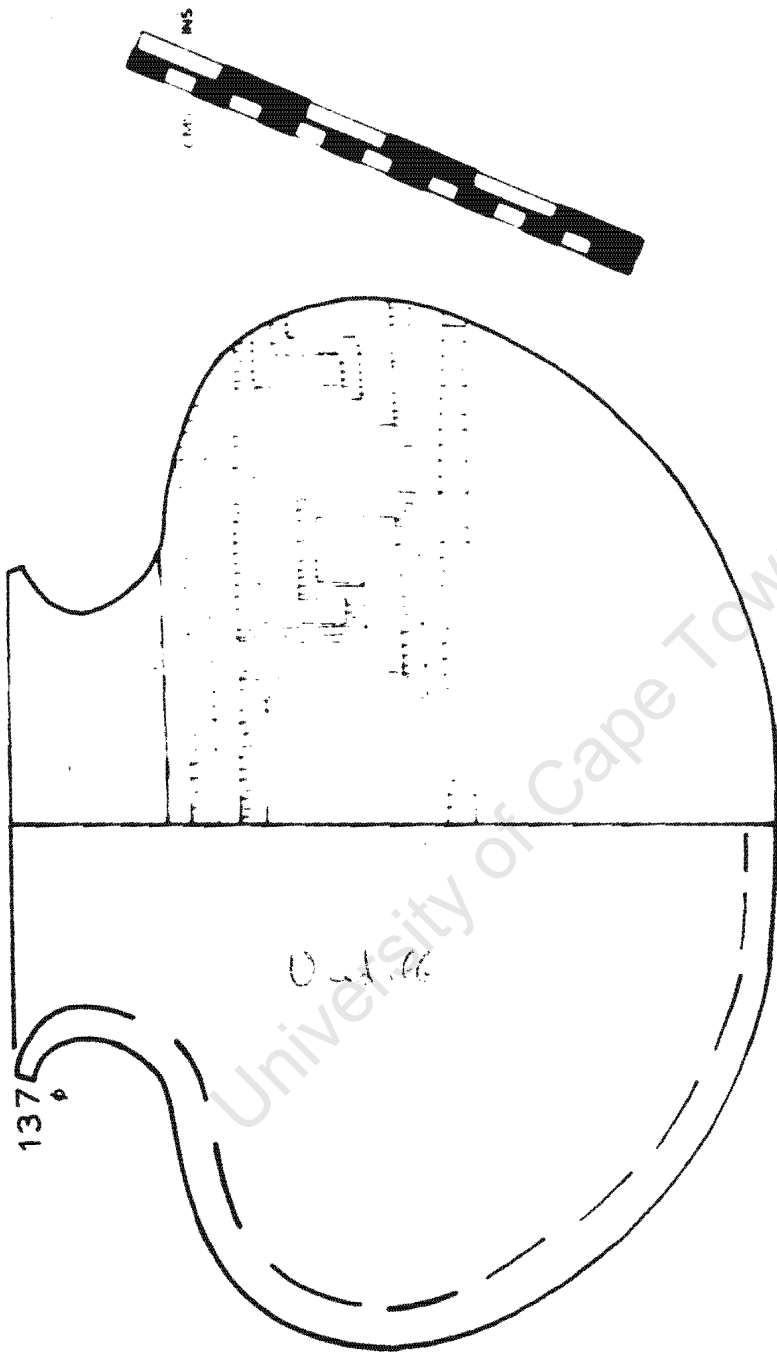

Figure XXXI

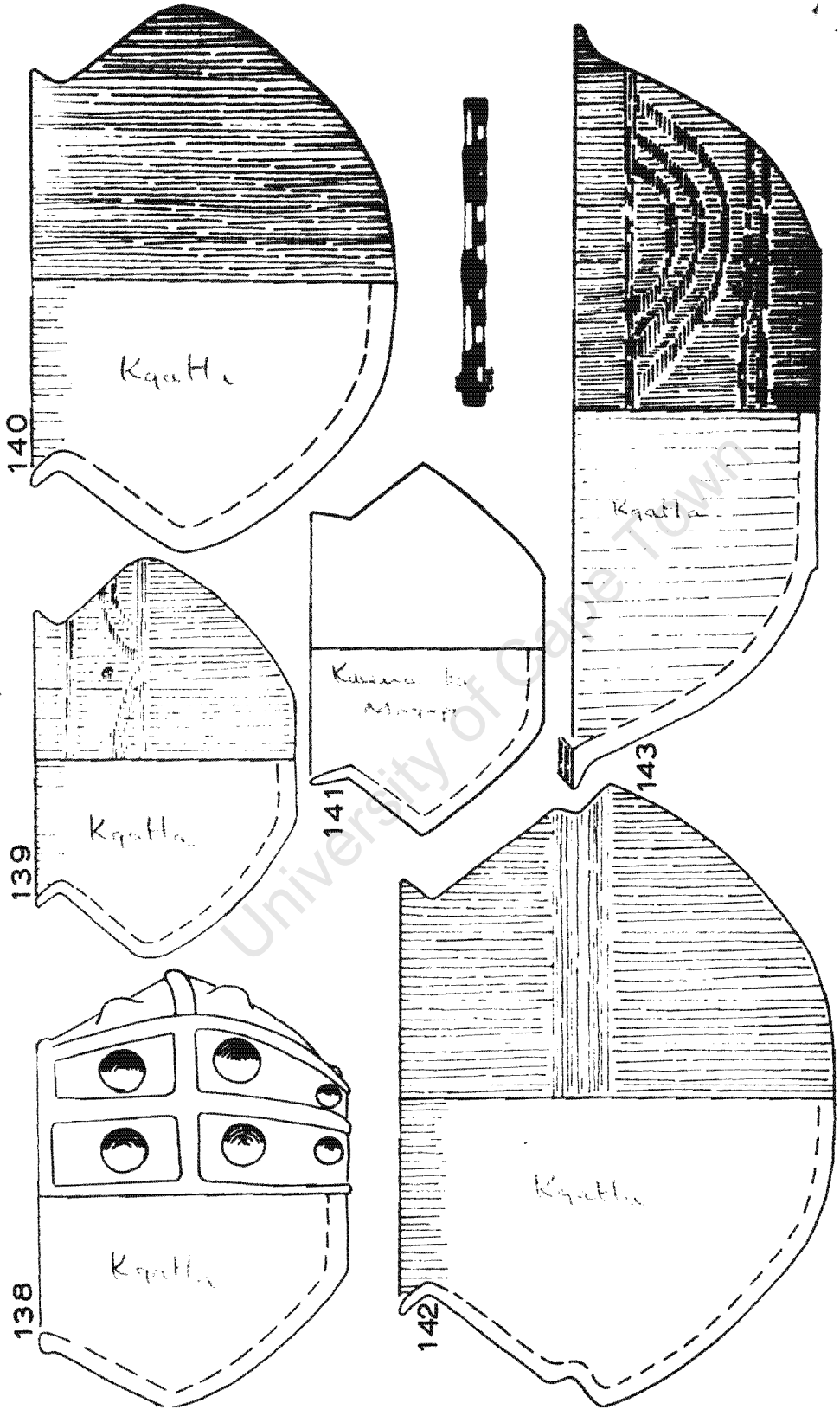

Figure XXXII

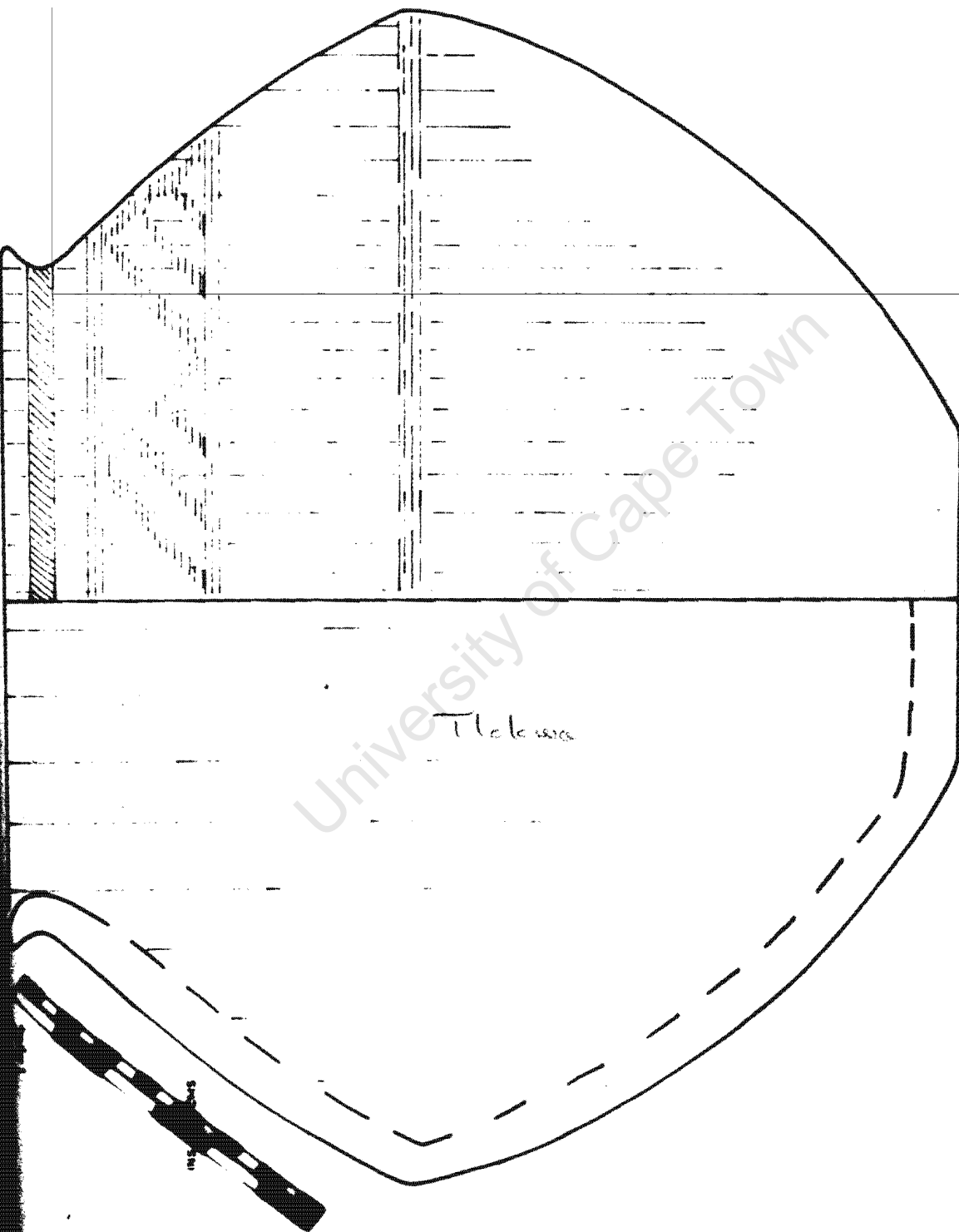

Figure XXXIII

University of Cape Town

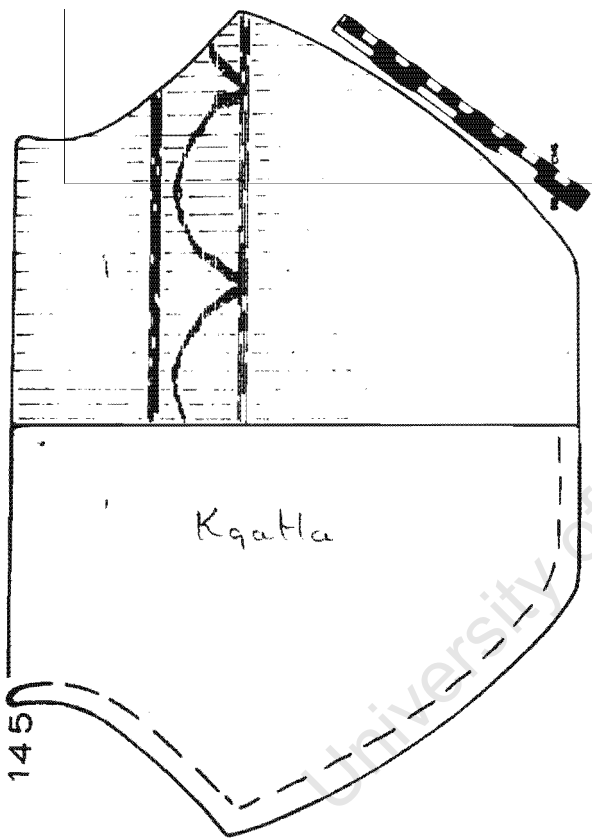

Figure XXXIV

University of Cape Town

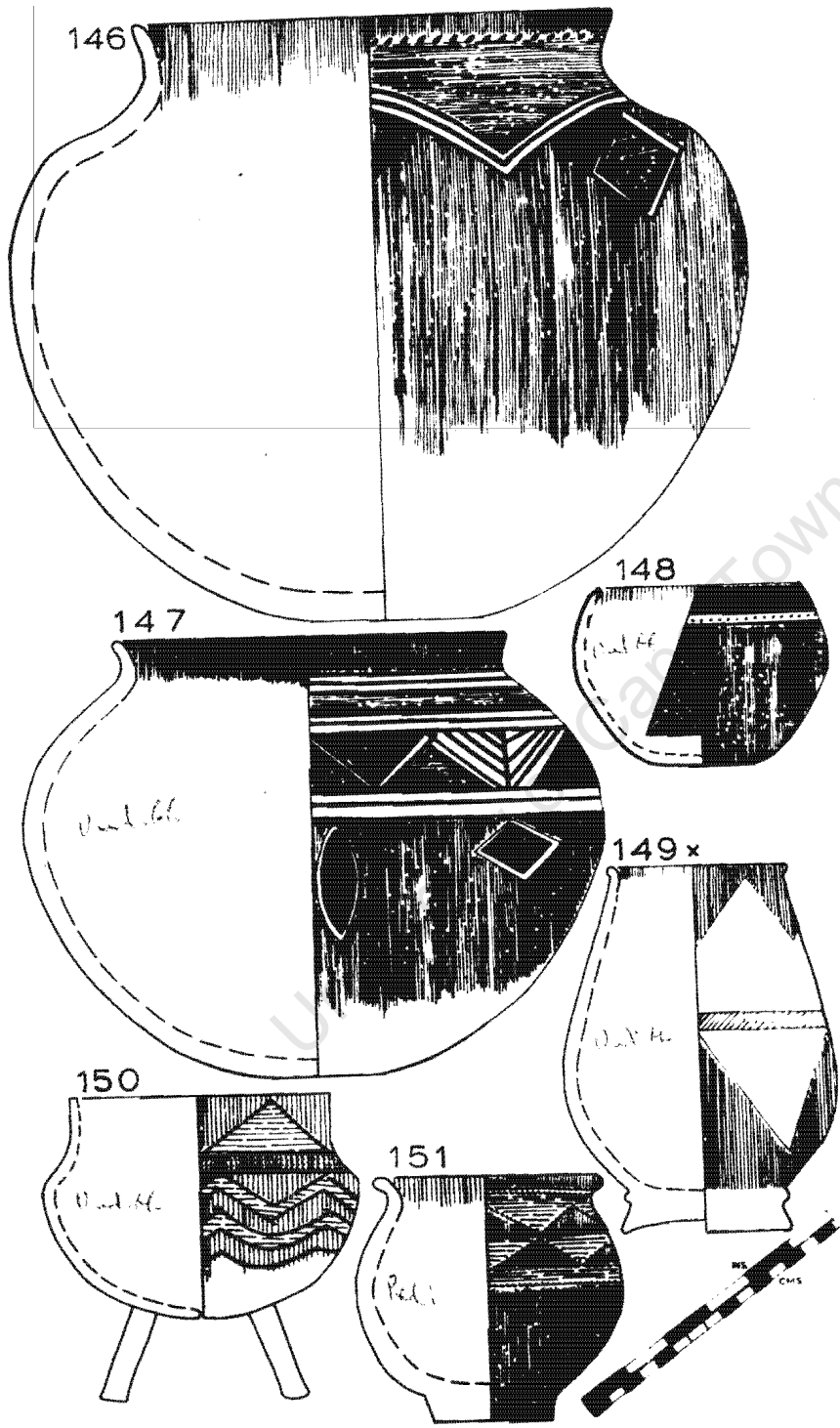

Figure XXXV

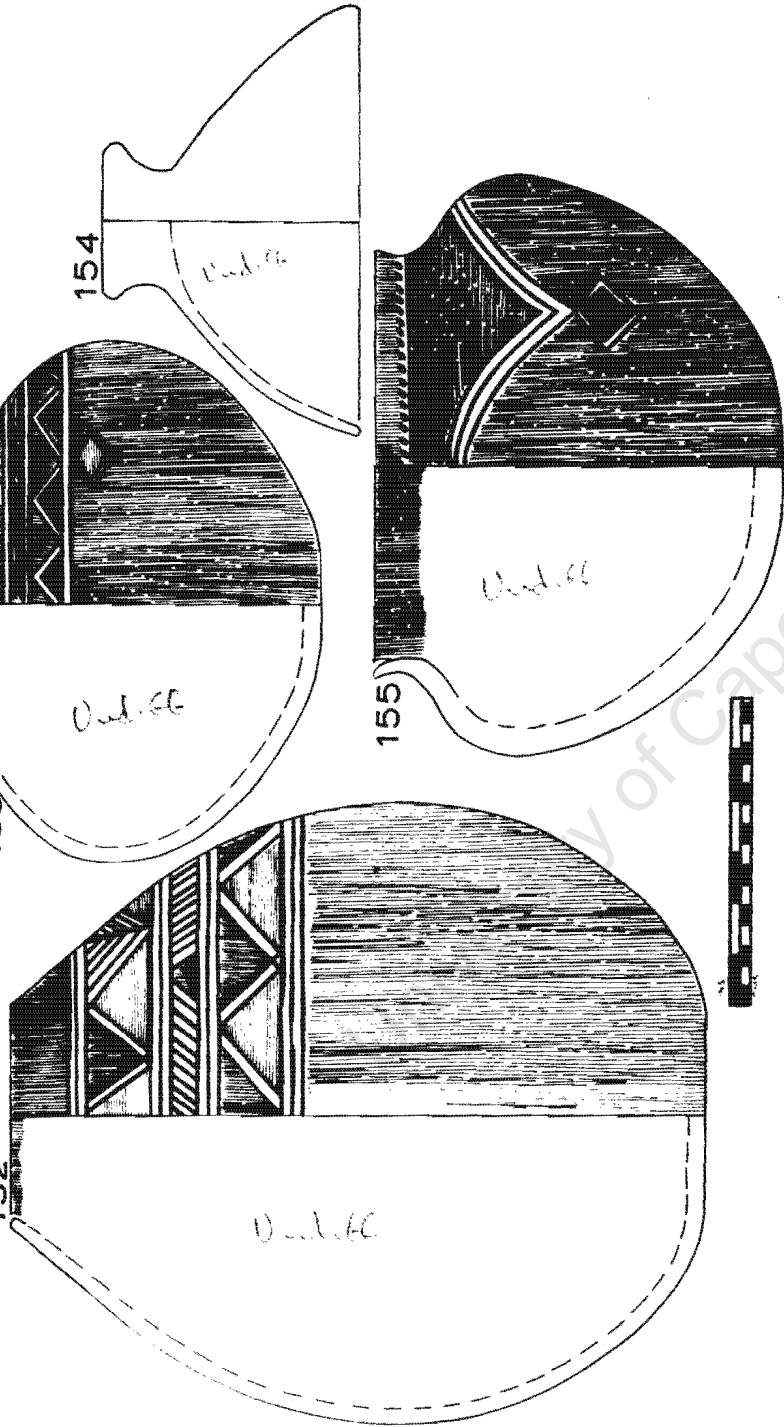

Figure XXXVI

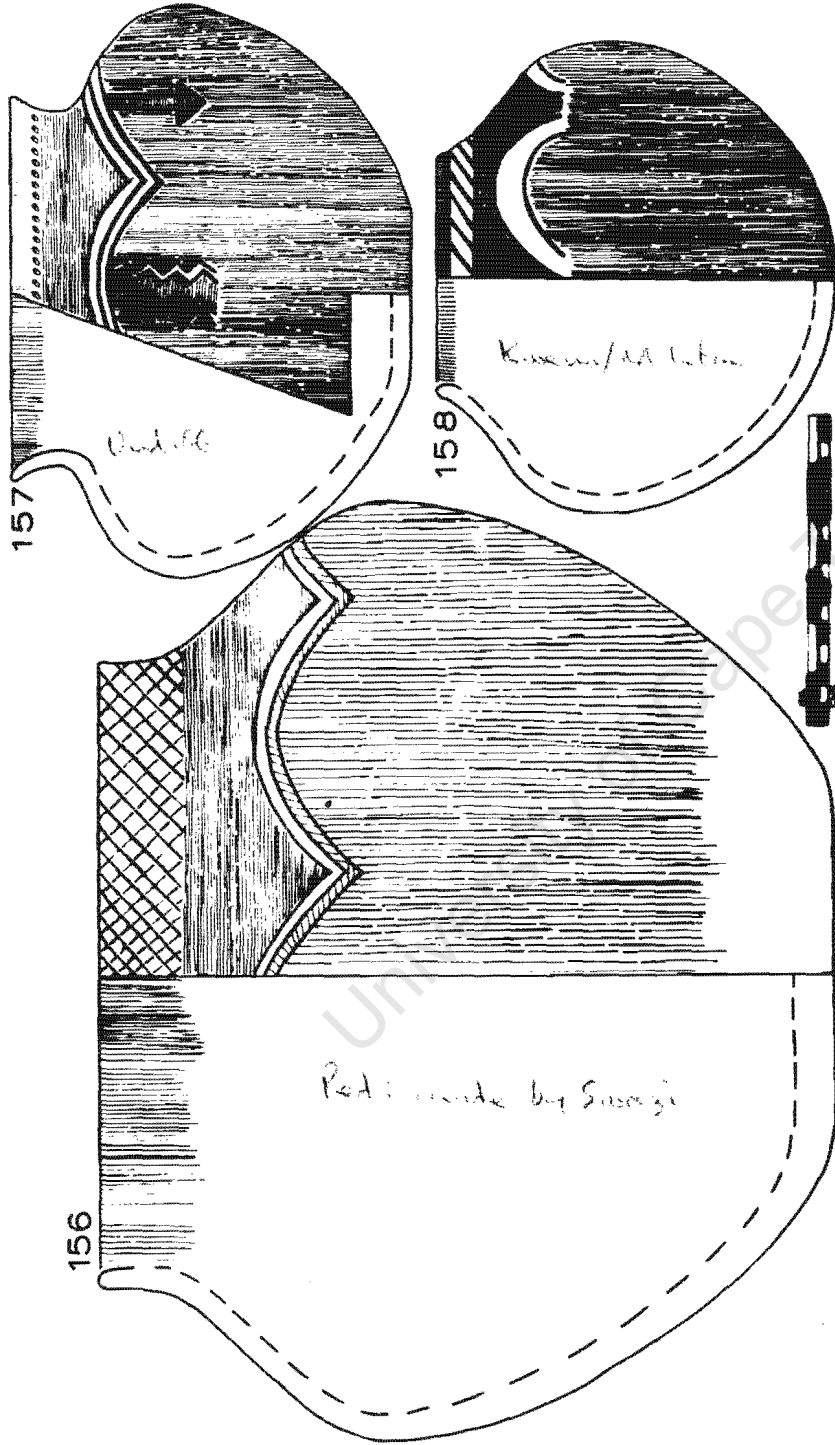

Figure XXXVII

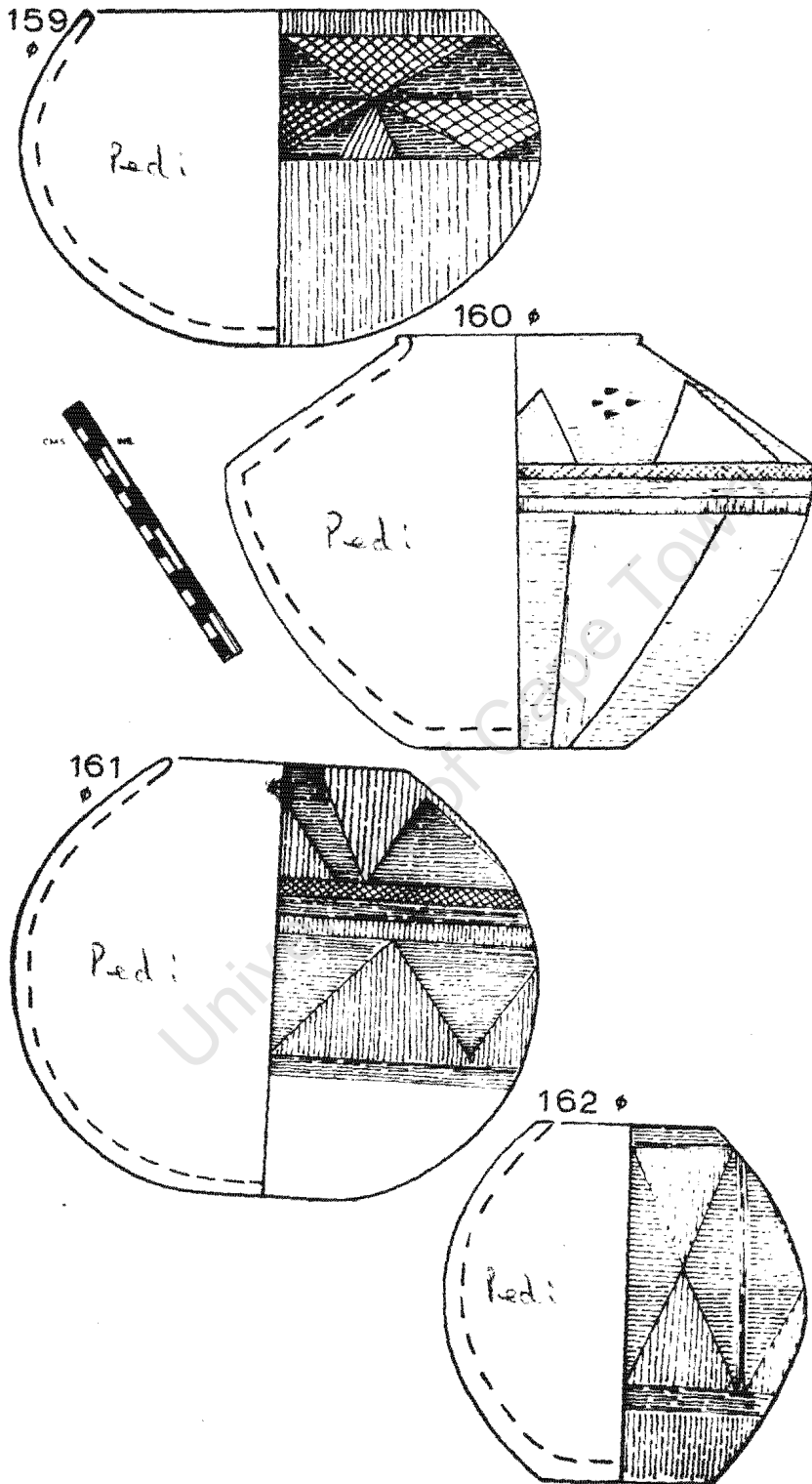

Figure XXXVIII

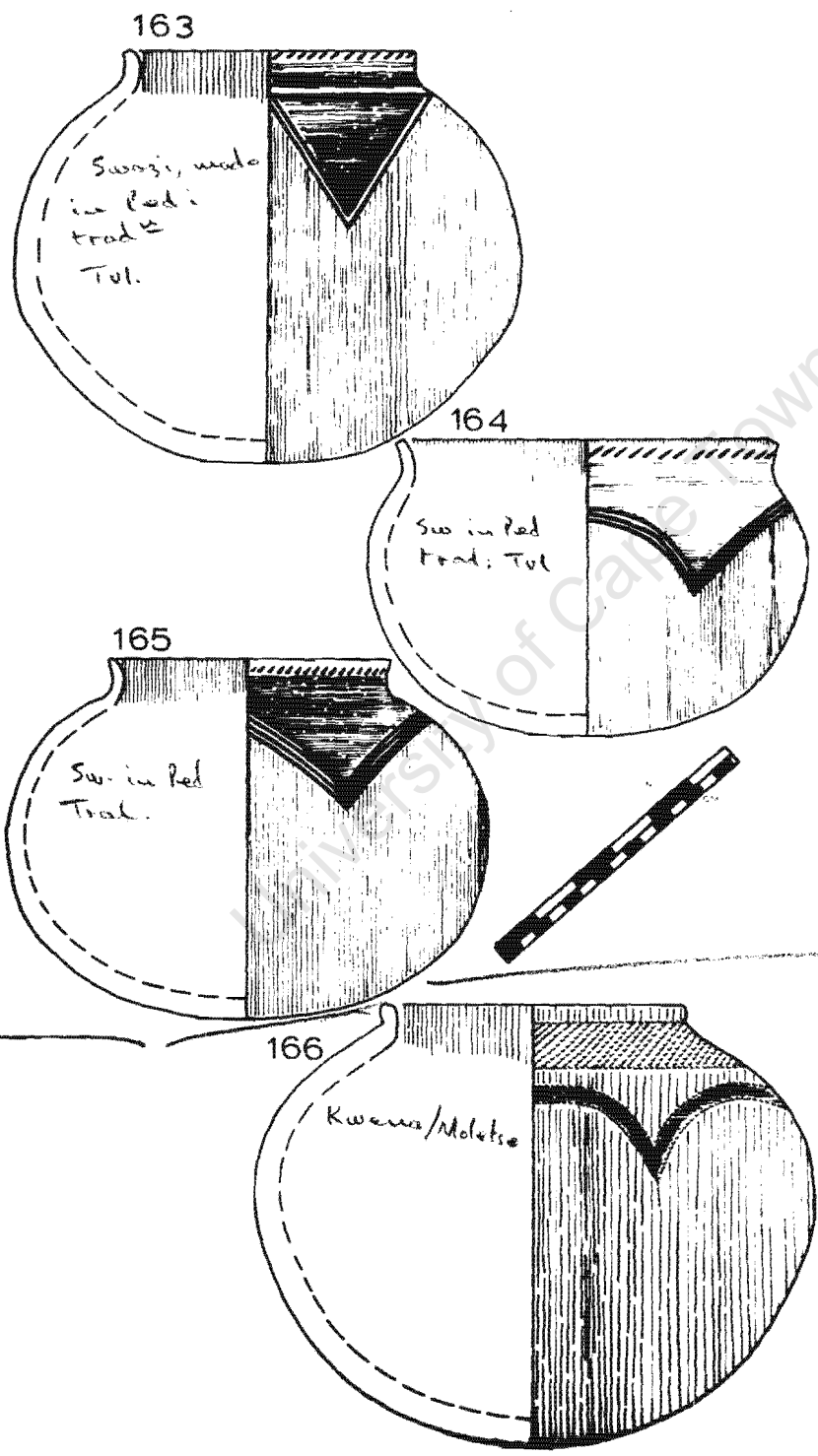

Figure XXXIX

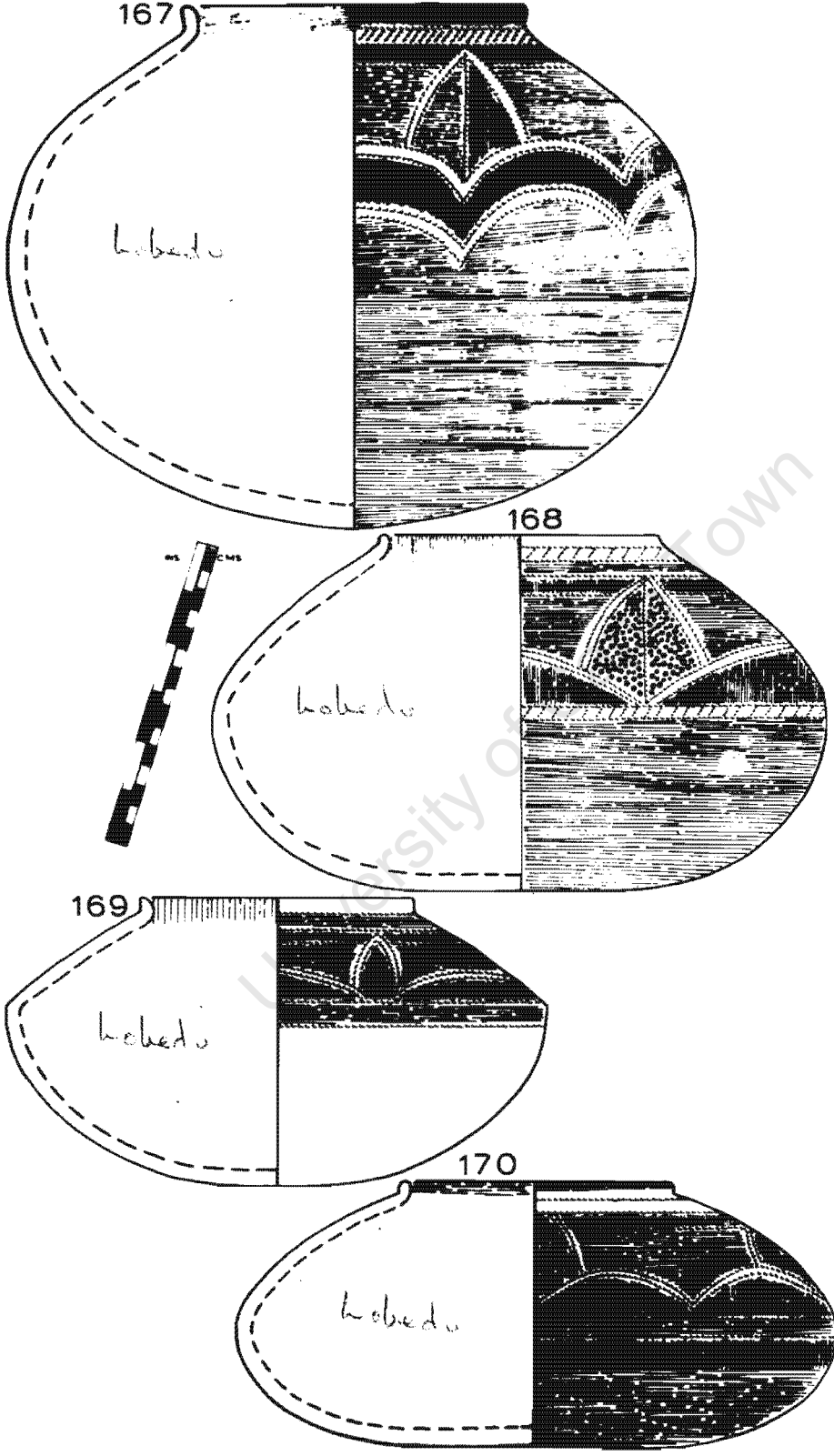

Figure XXXX

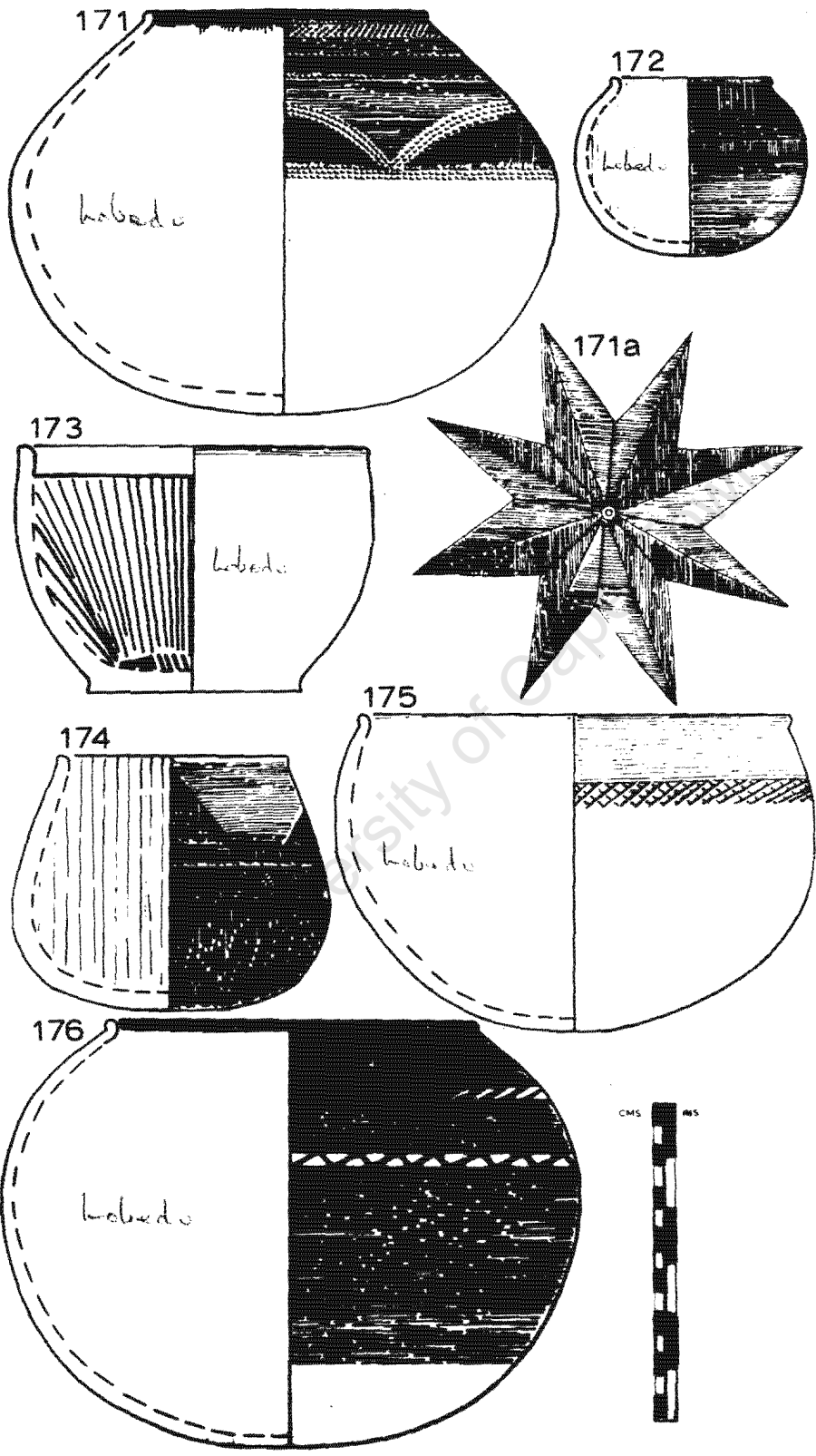

Figure XXXXI

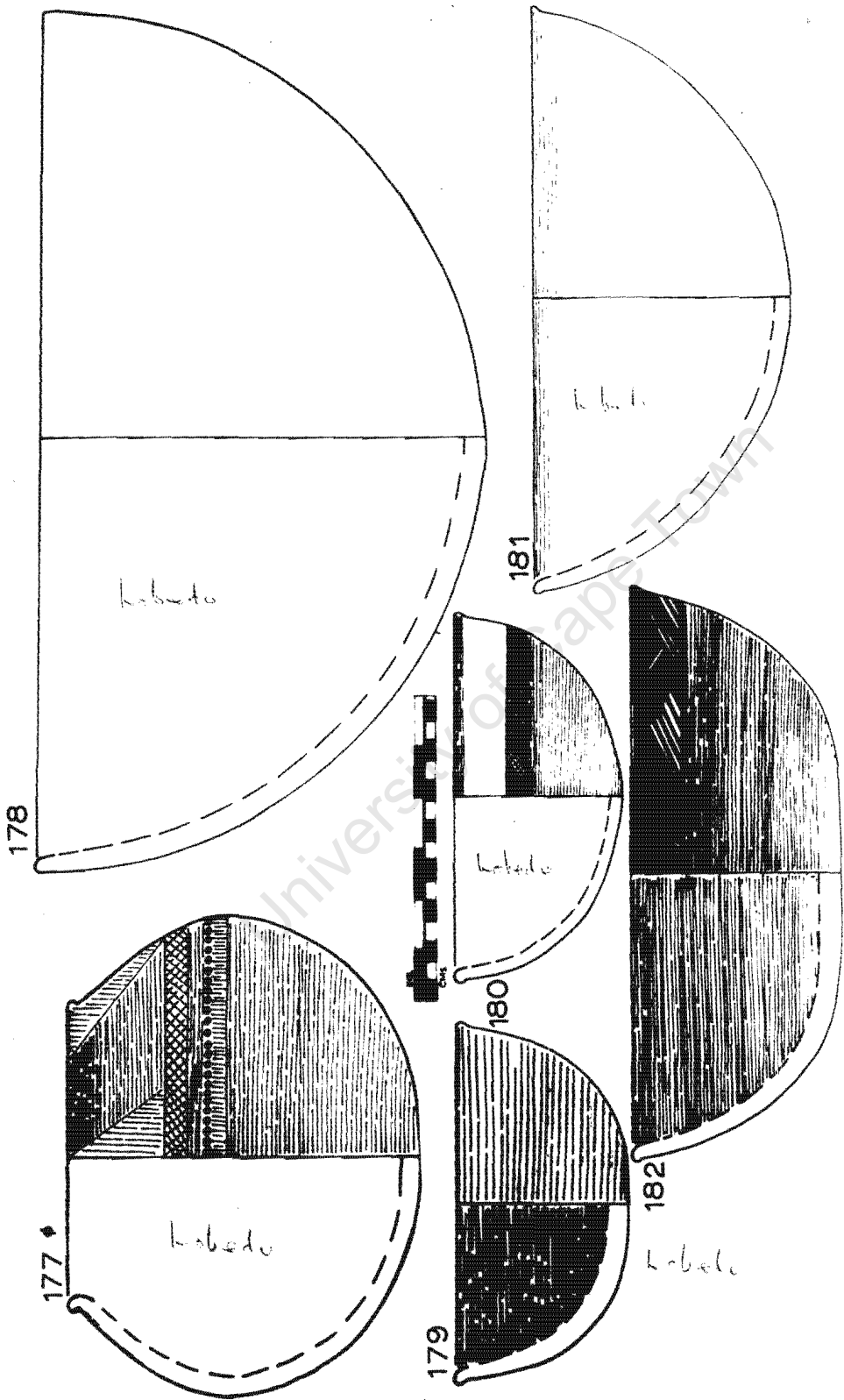

Figure XXXXII

kabela

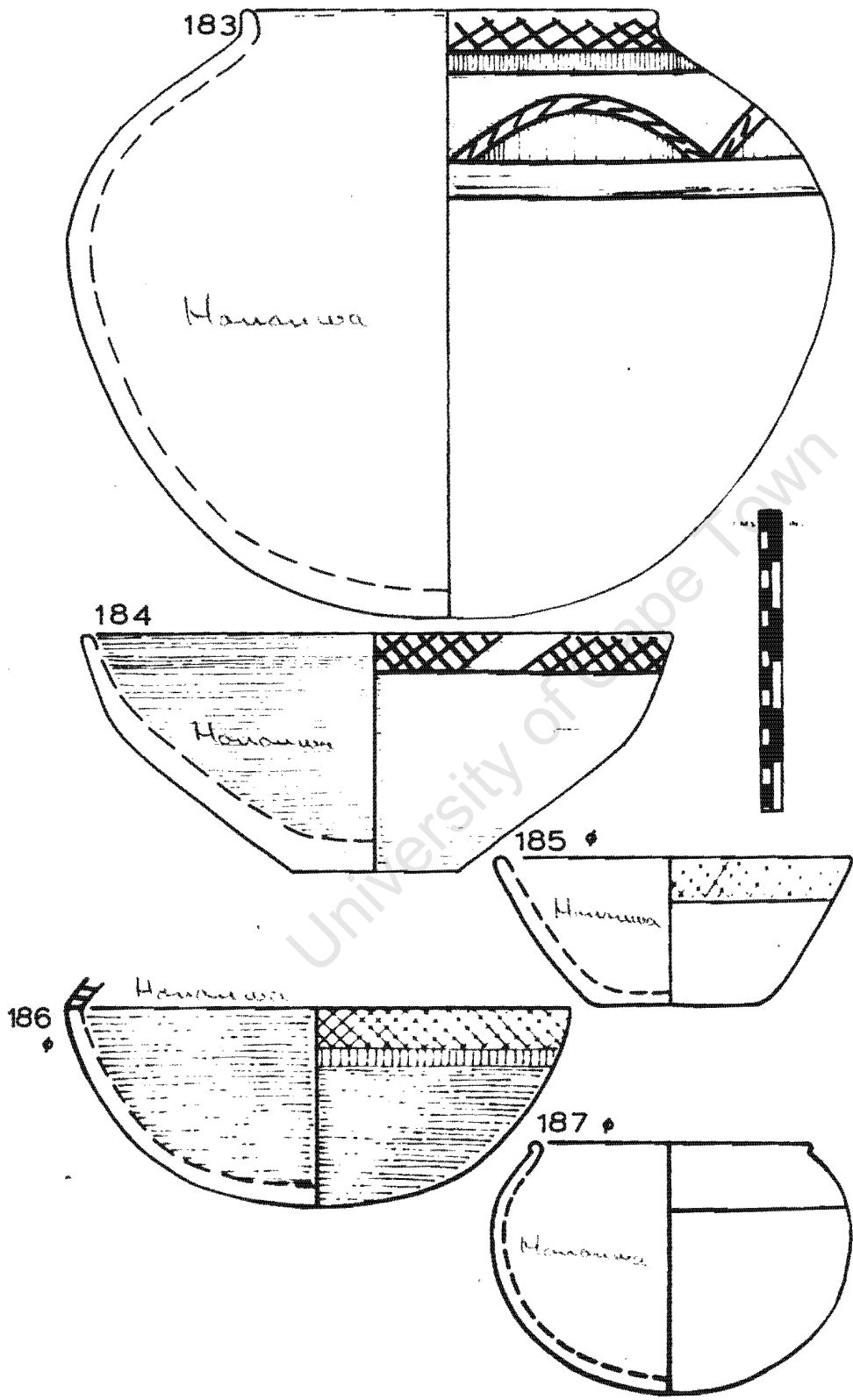

Figure XXXXIII

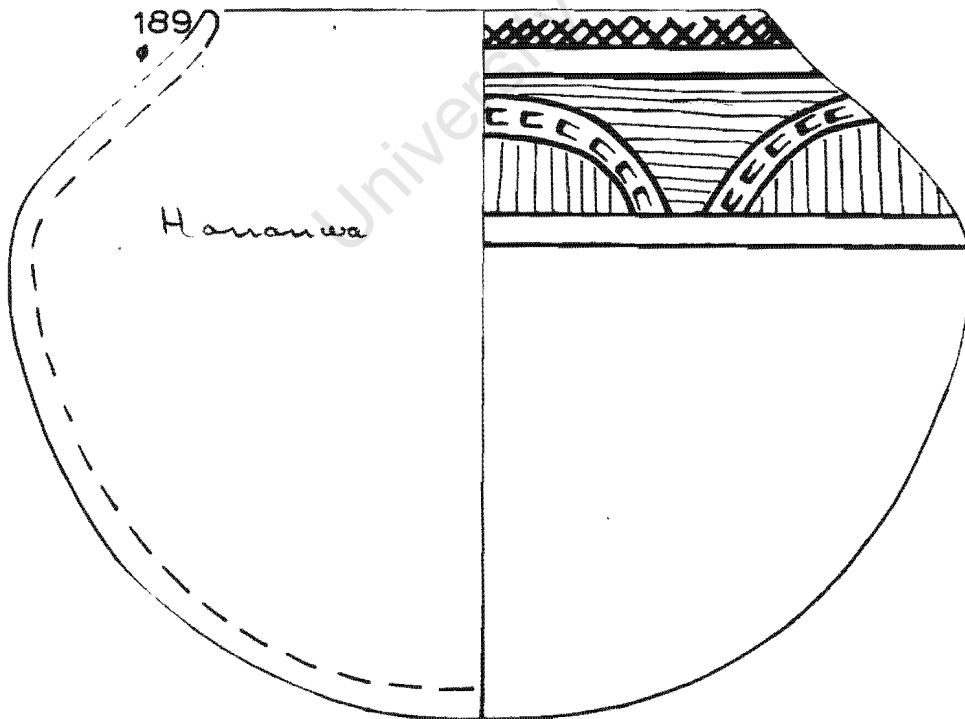
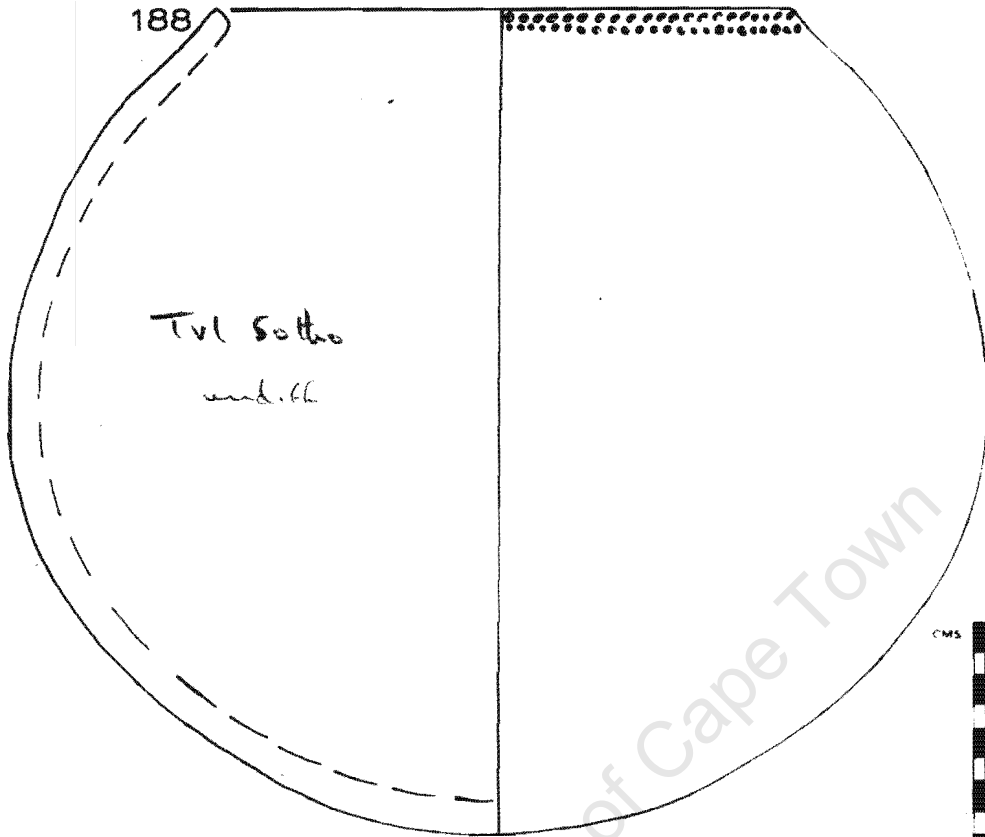

Figure XXXIV

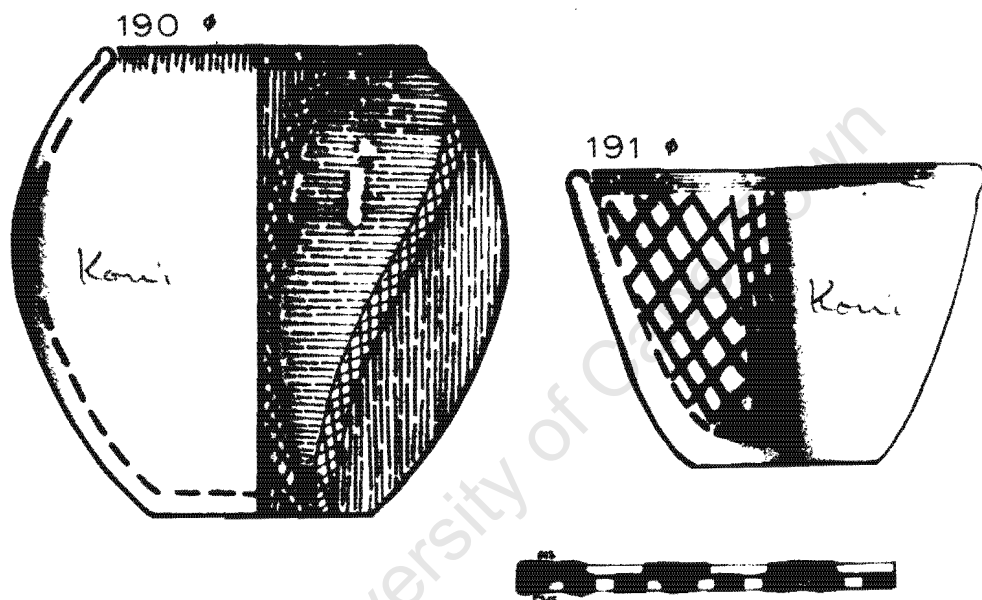

Figure XXXXV

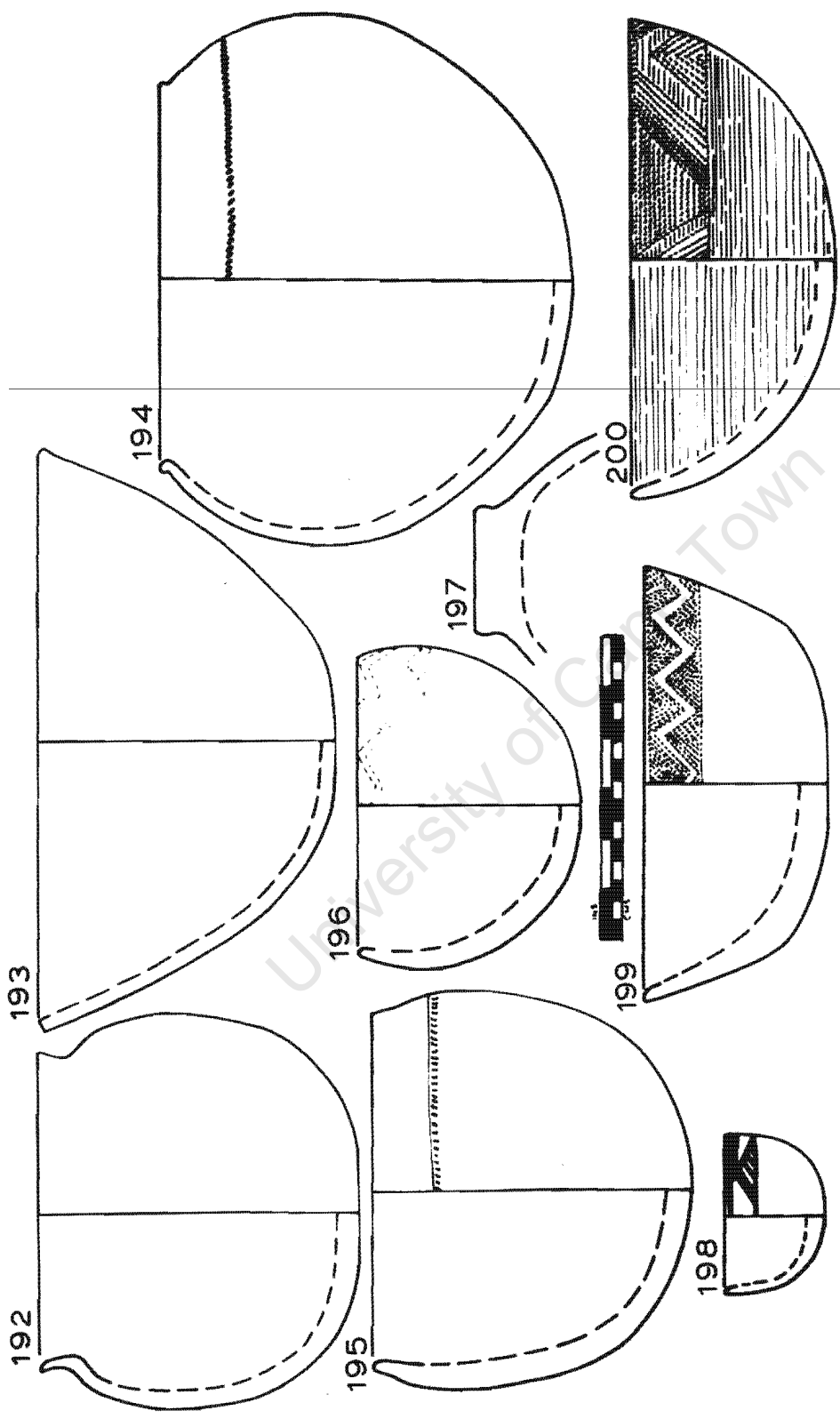

FIG XXXXVI

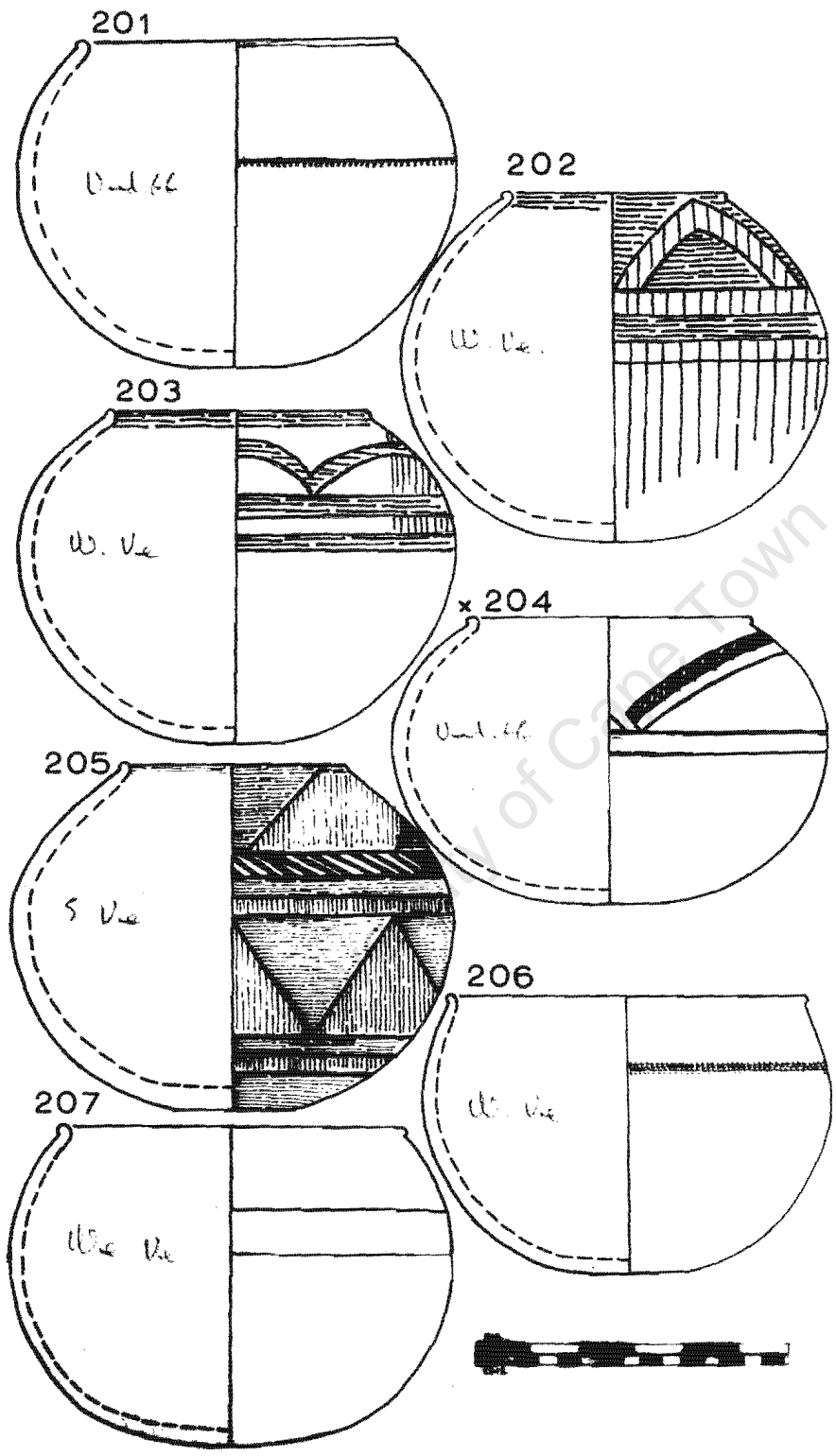

Figure XXXVII

Venda

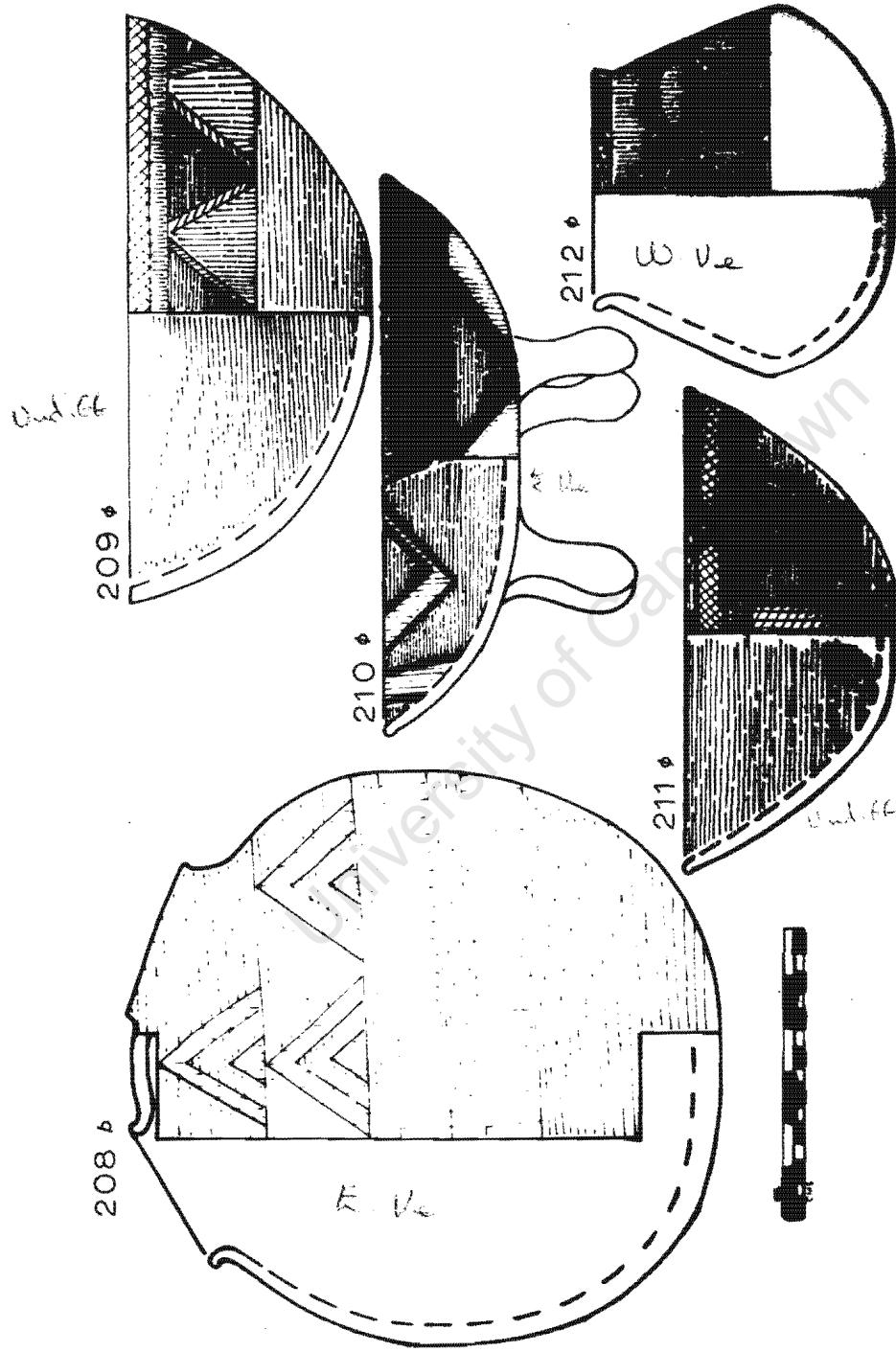
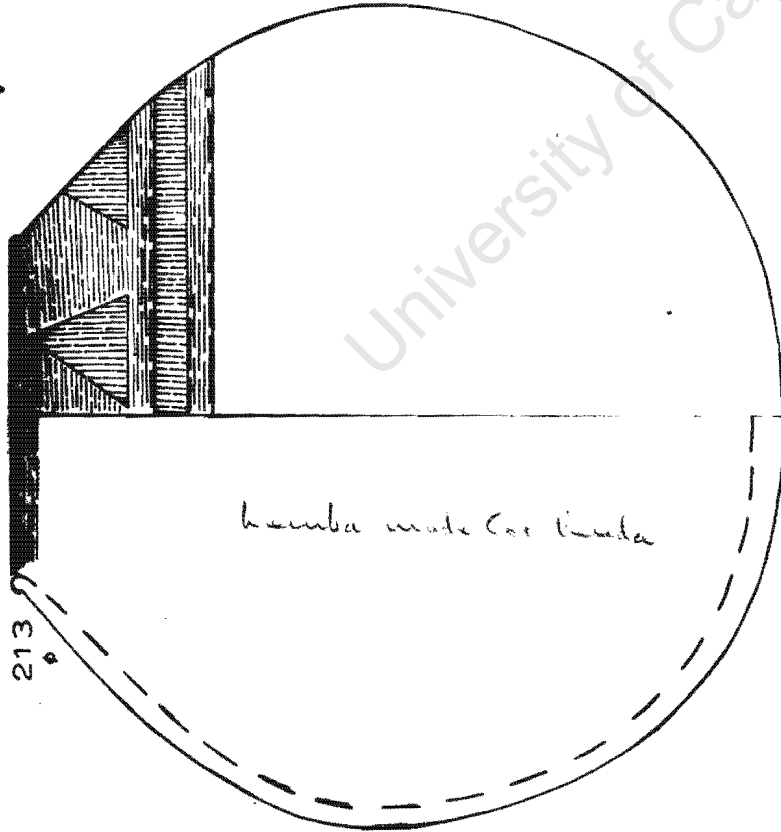
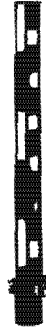
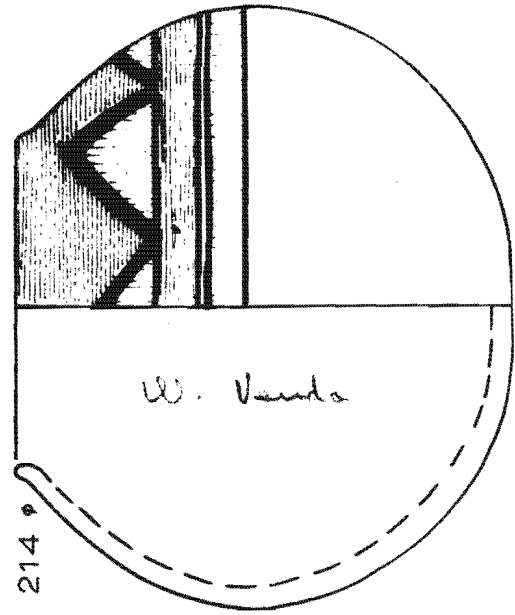

Figure XXXXVIII

Verda + Lumba



University of Cape Town

Figure XXXXIX

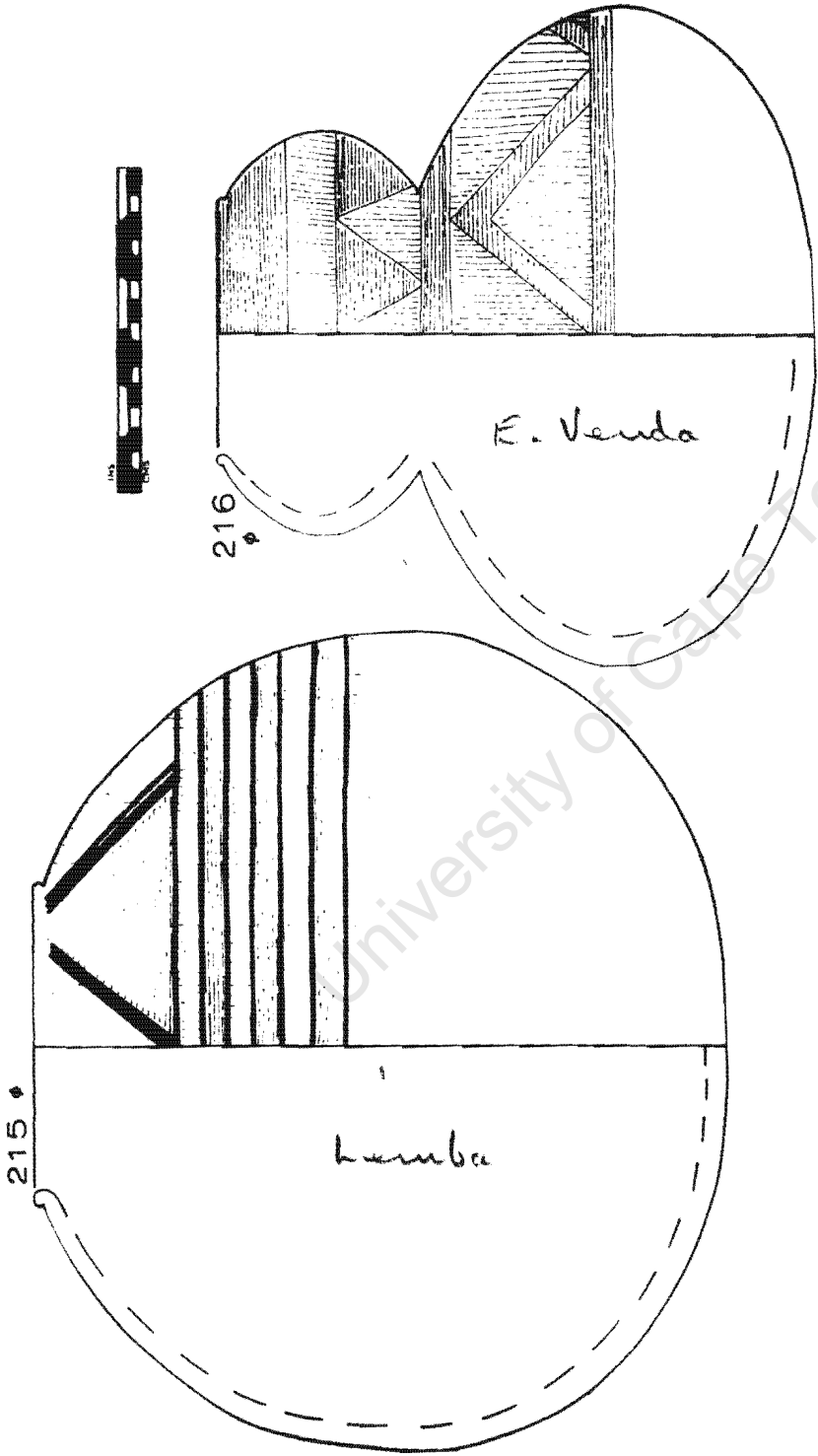

Figure L

Venda

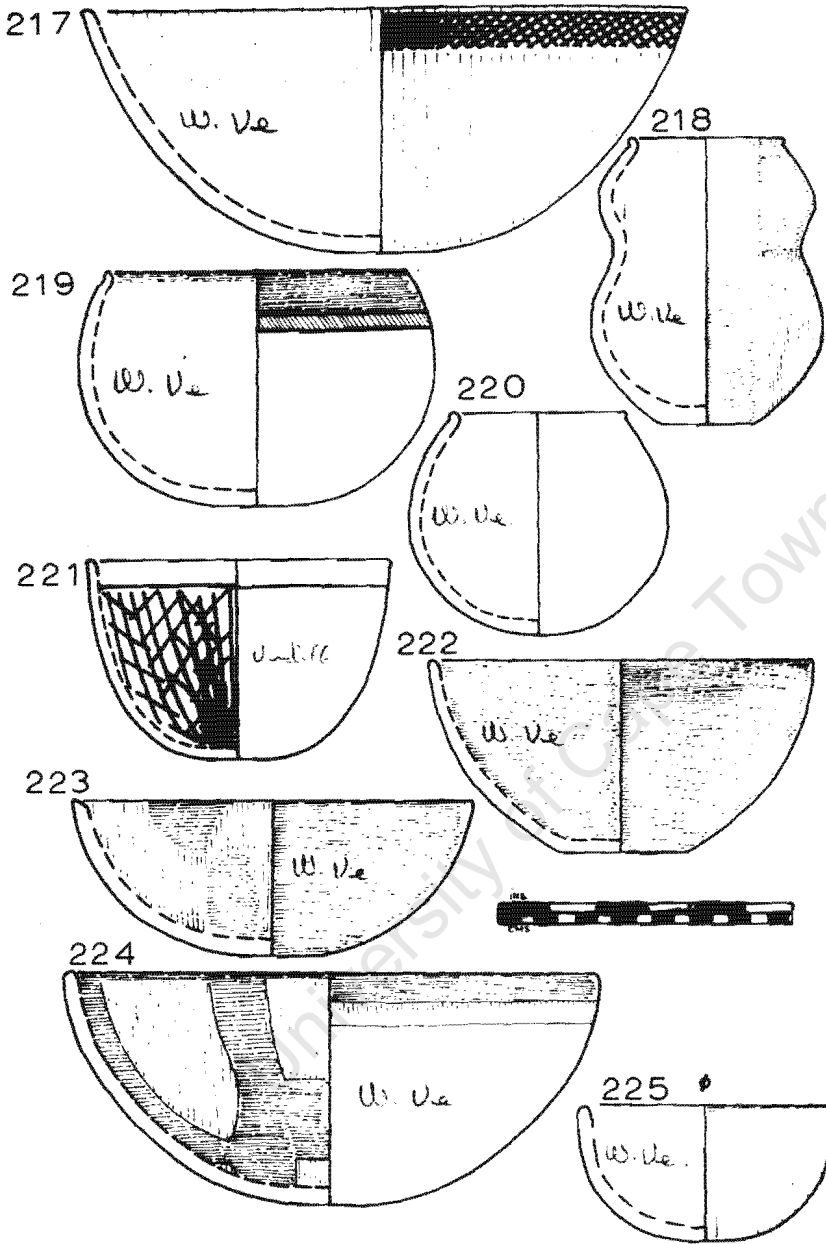

Figure LI

Kamba

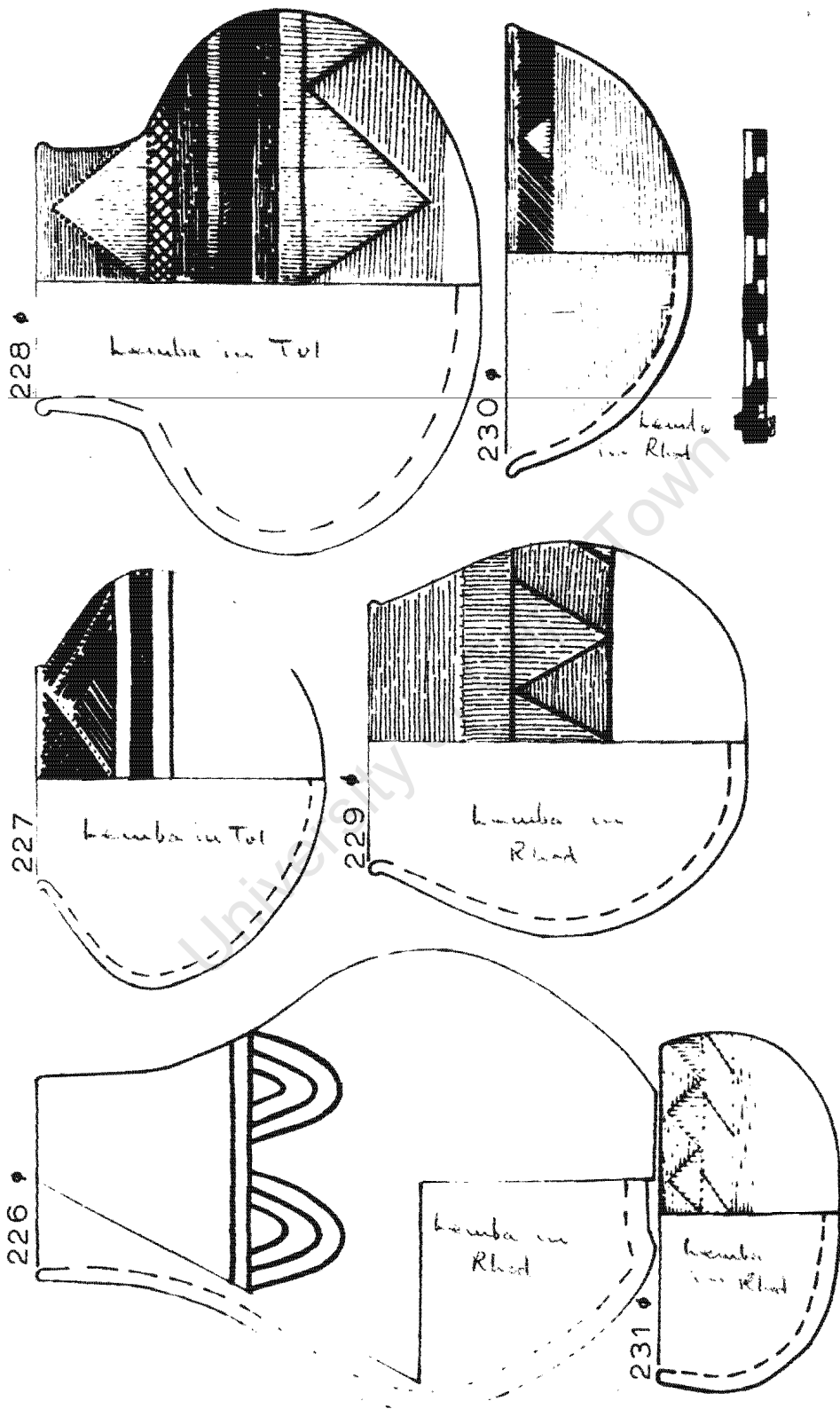

Figure LII

all Lemba in Tol.

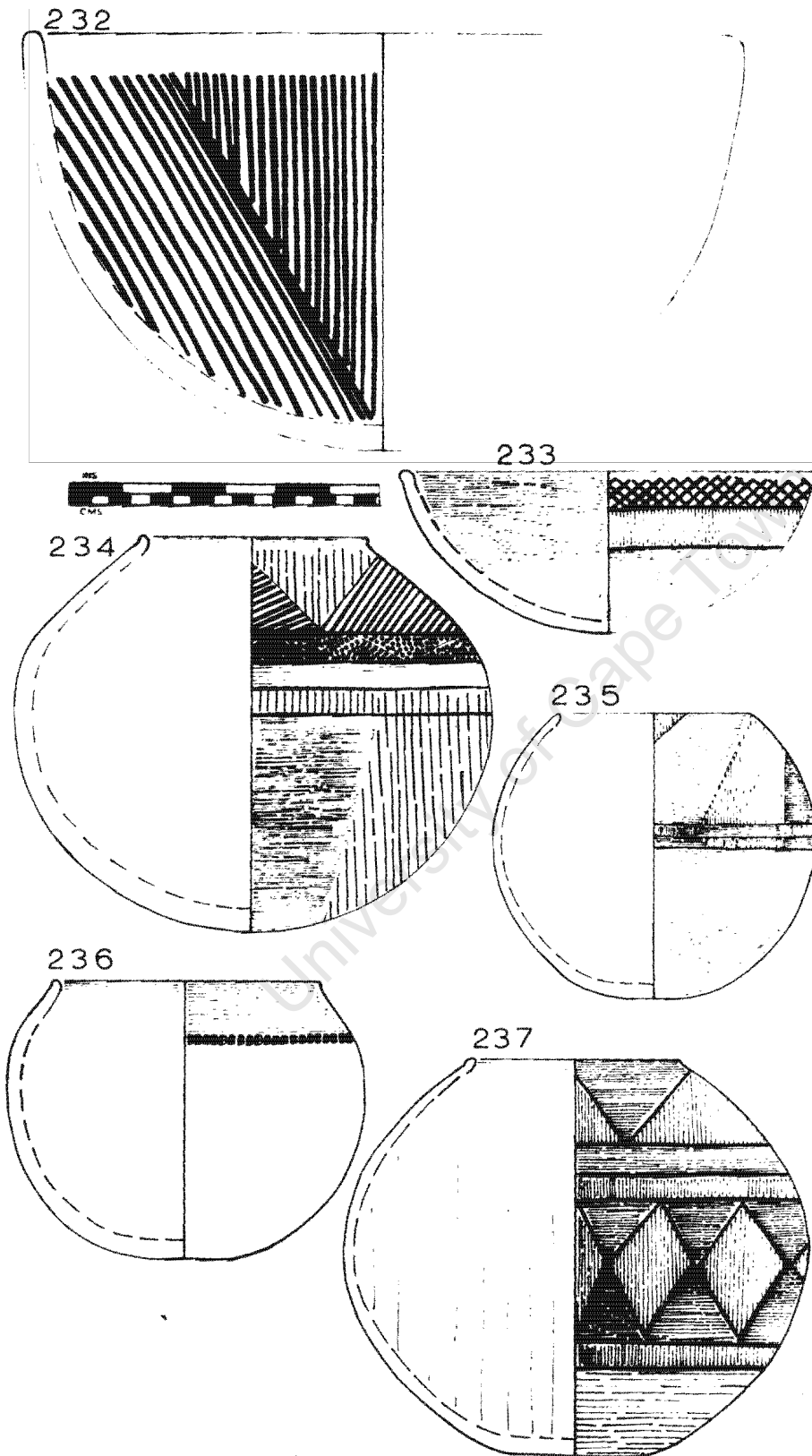
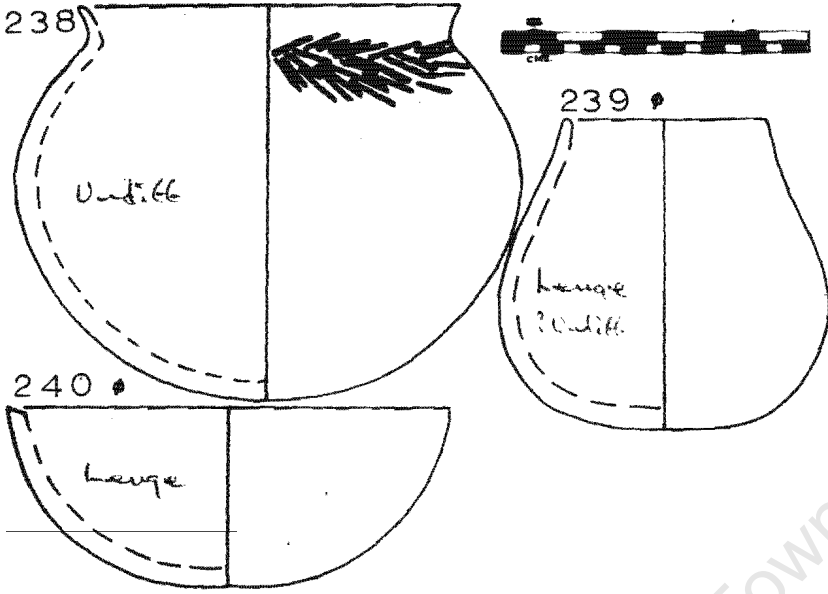

Figure LIII



University of Cape Town

Figure LIV

Bitonqa
(=Khokha)

CHOPI

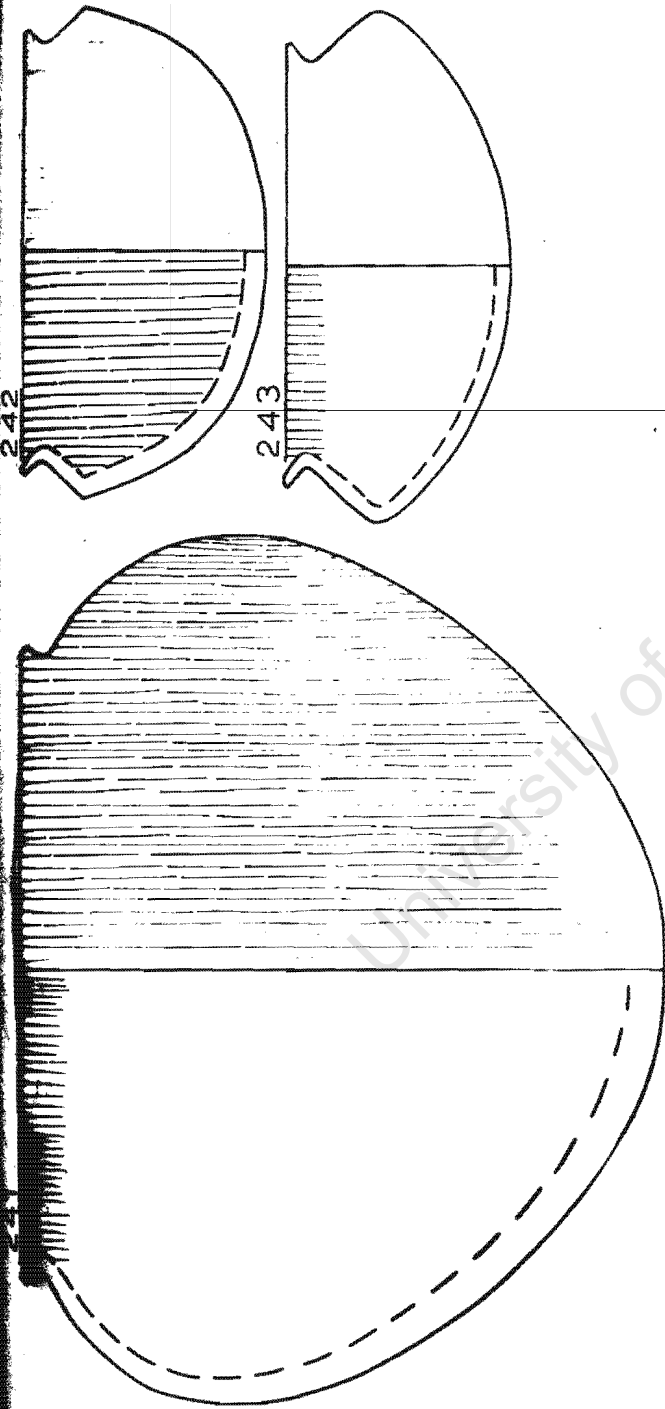
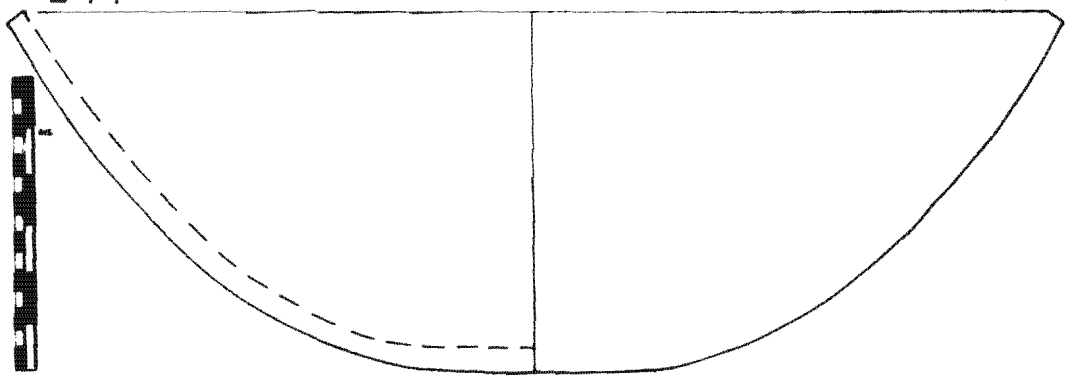

Figure LV

Bitounga
(= Kholoha)

CHOP

244



University of Cape Town

Figure LVI

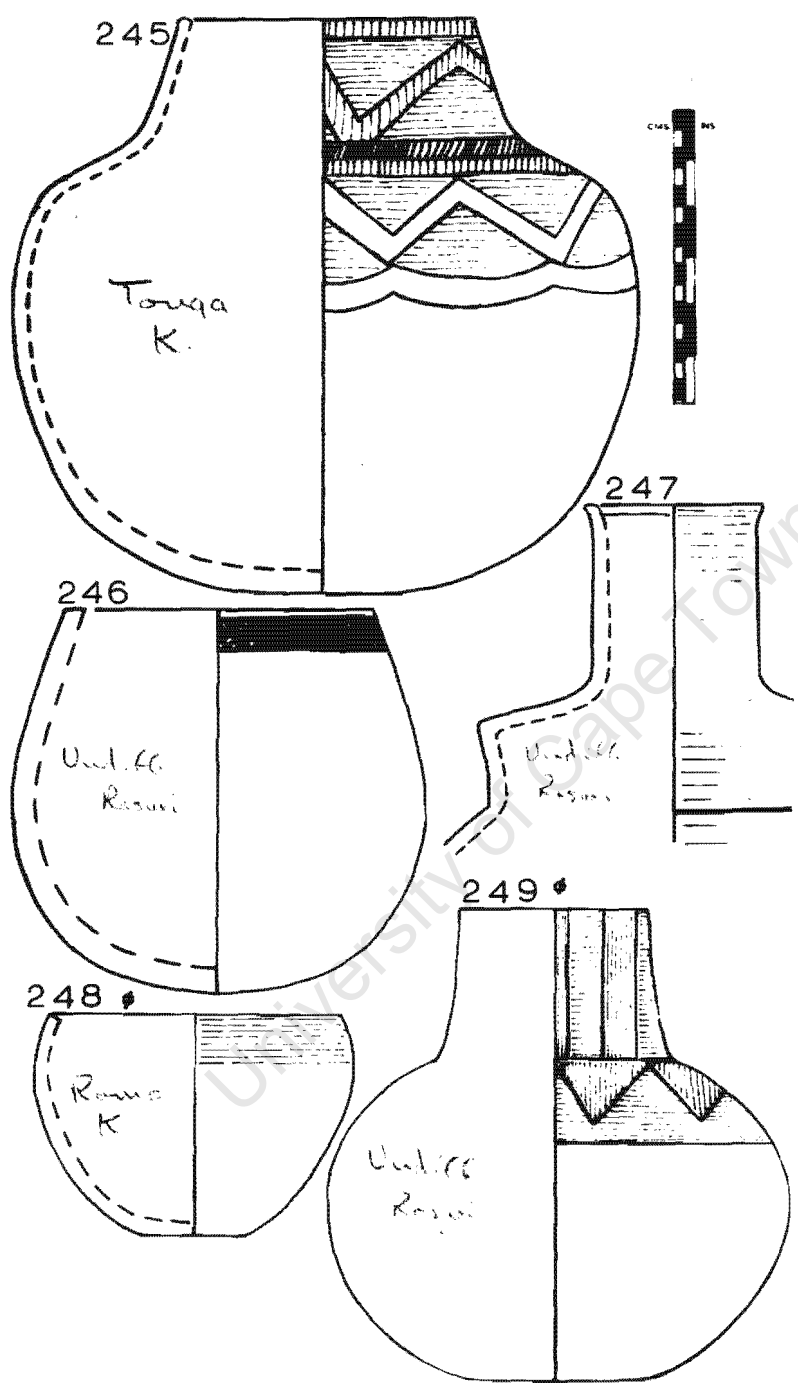

Figure LVII

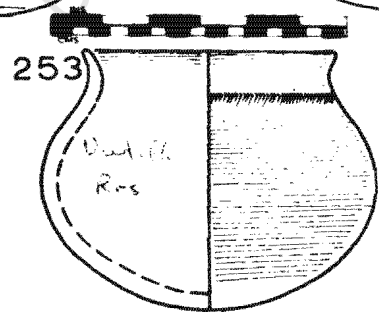
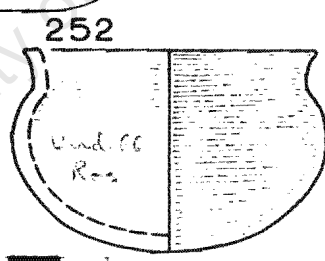
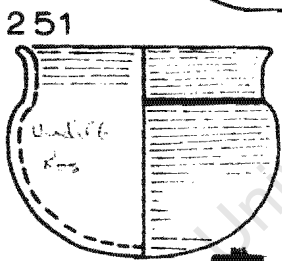
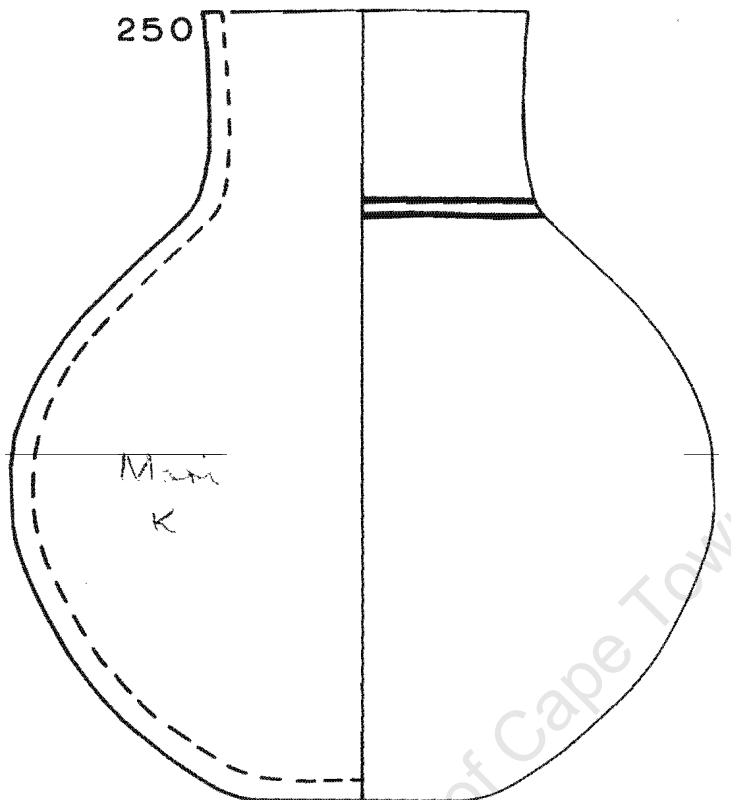

Figure LVIII

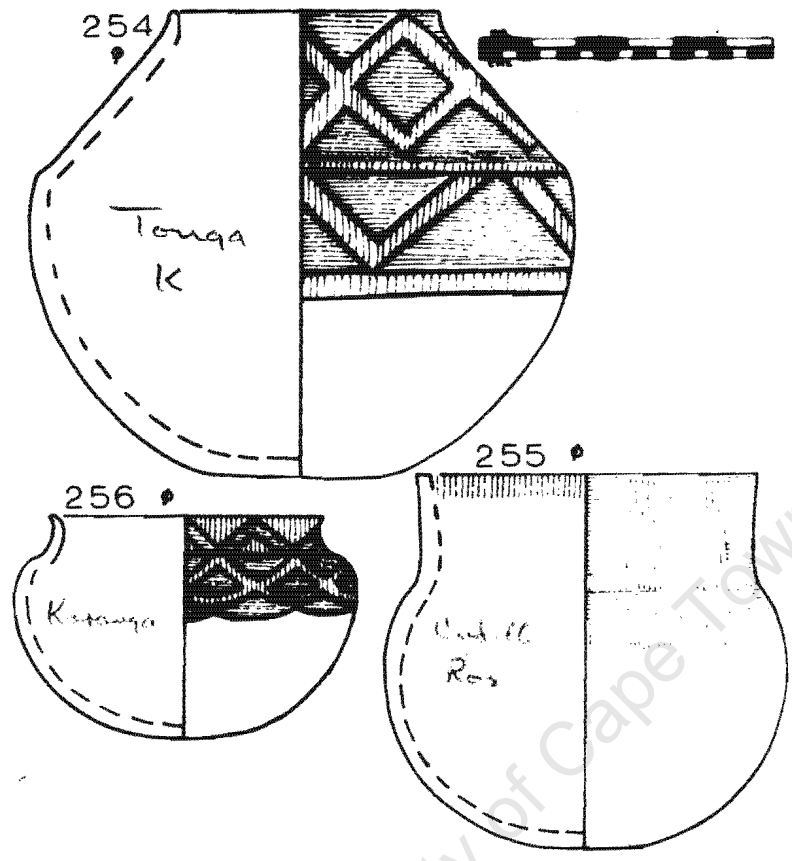

Figure LIX

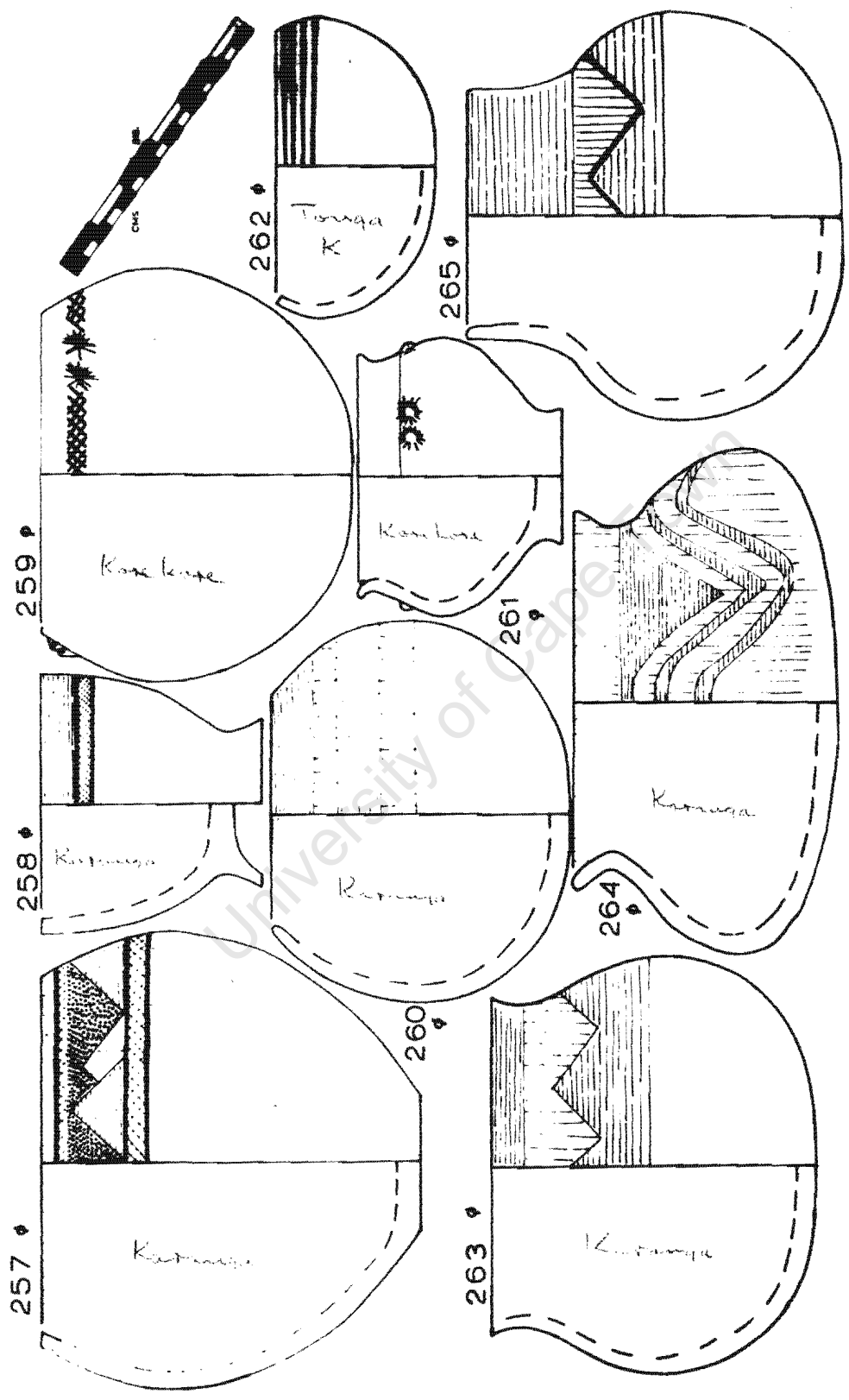

Figure LX

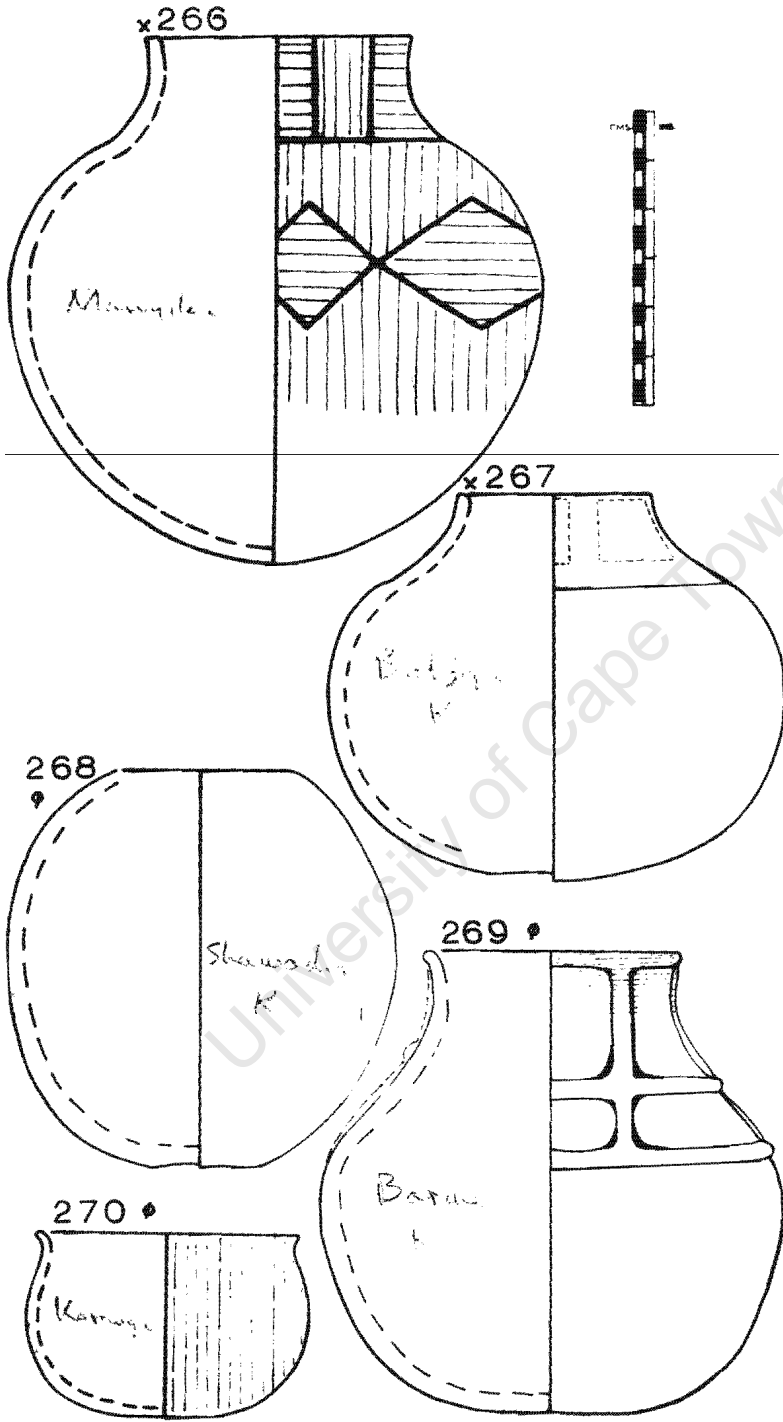

Figure LXI

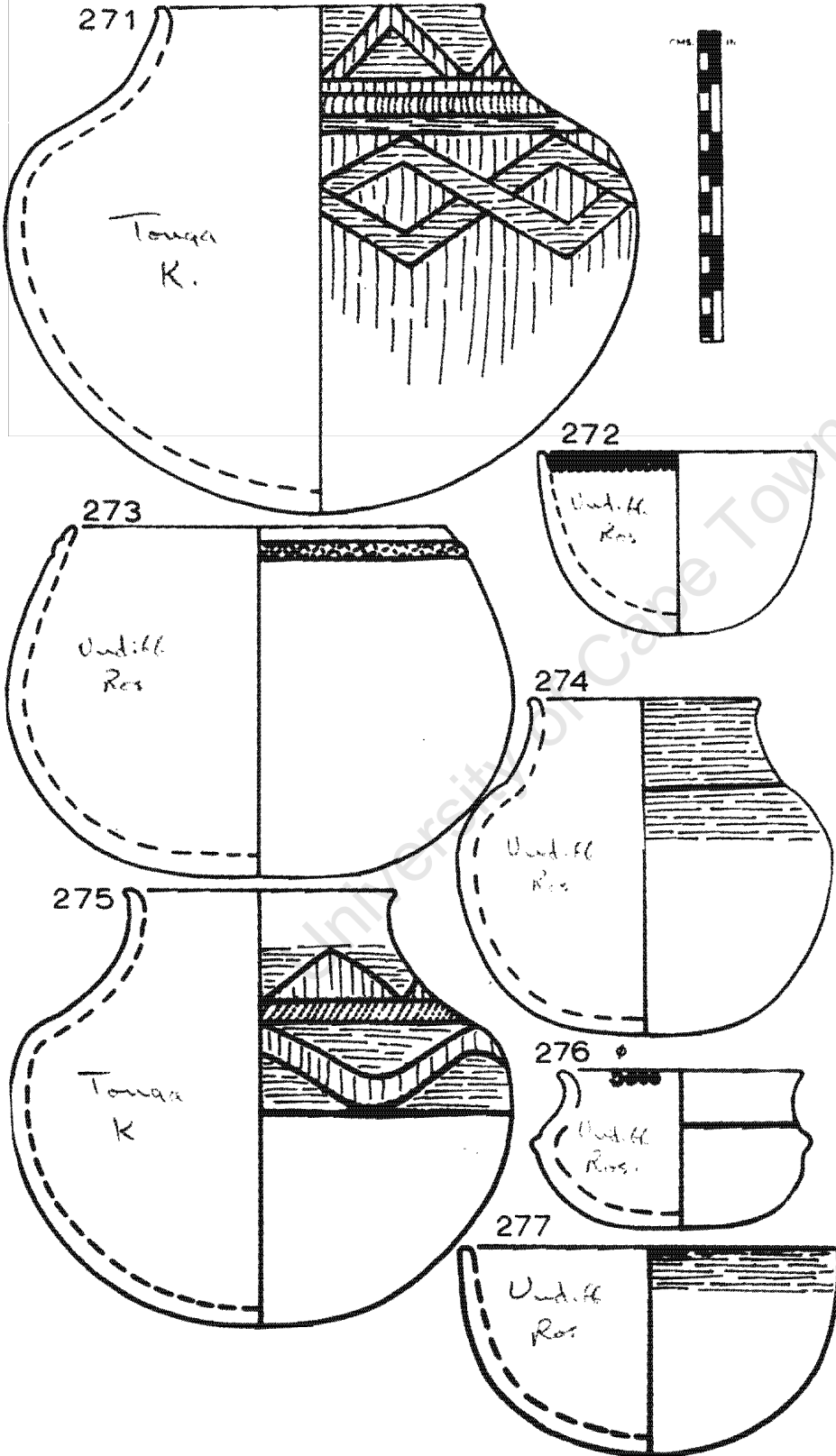

Figure LXII

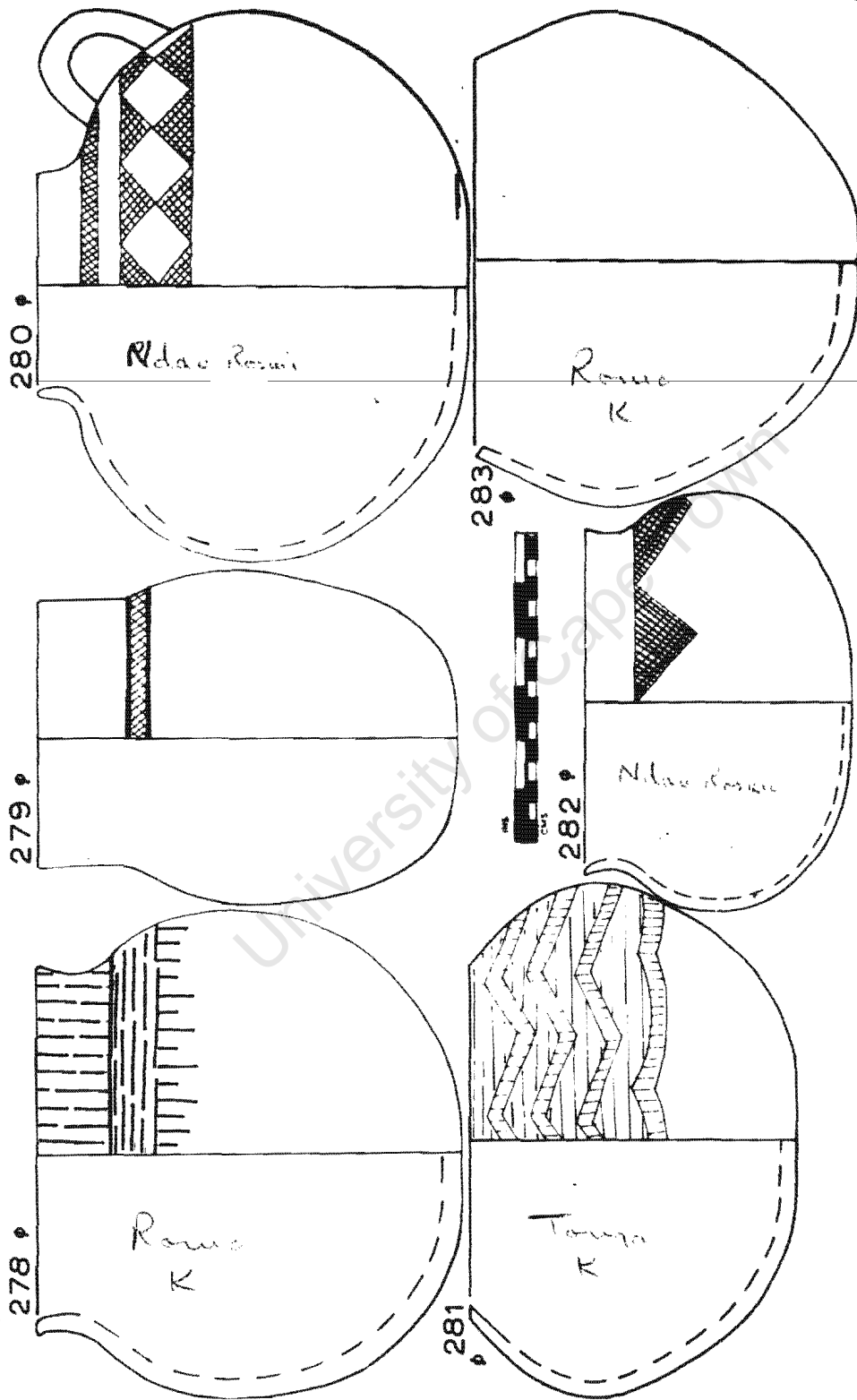

Figure LXIII

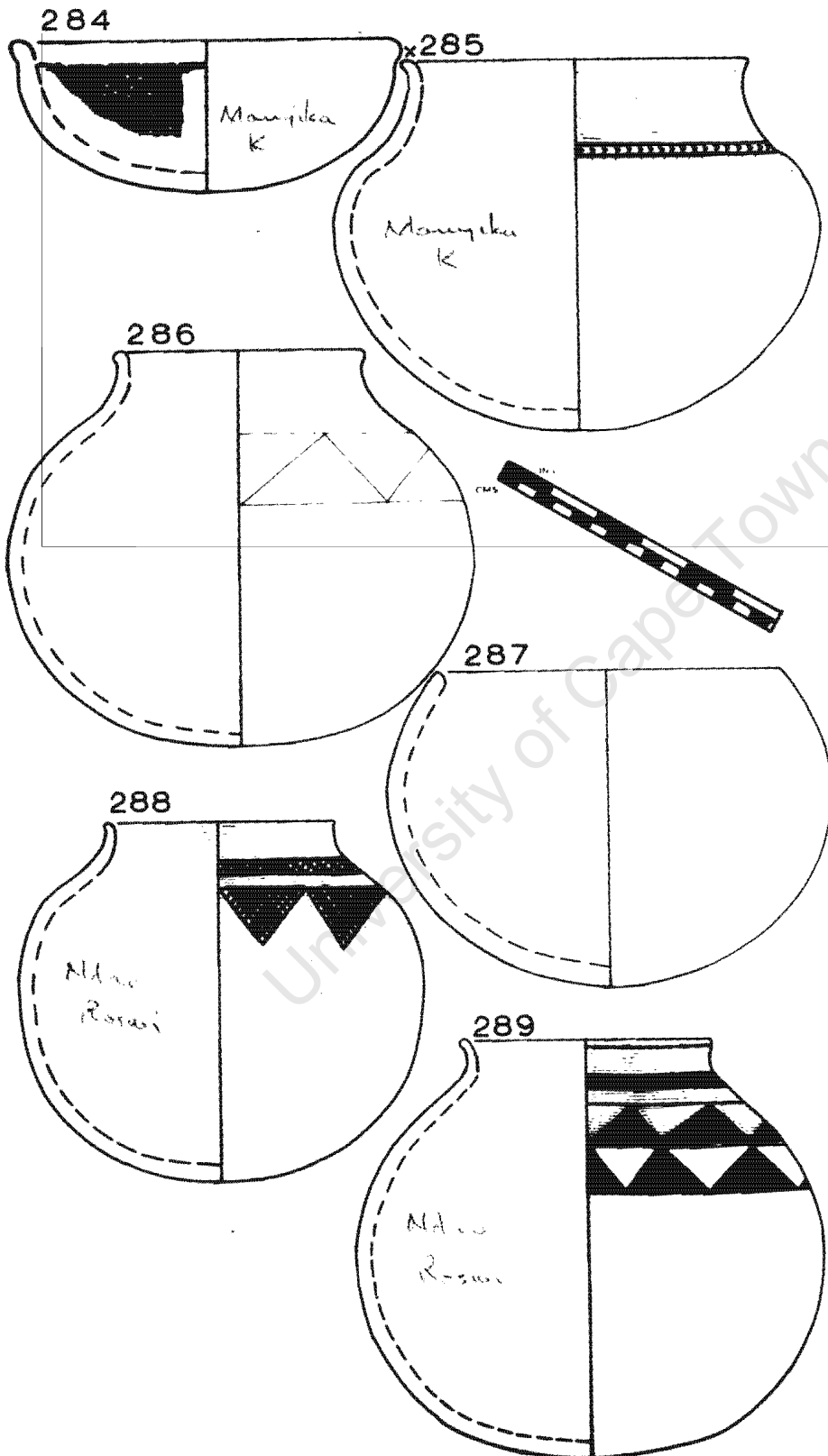

Figure LXIV

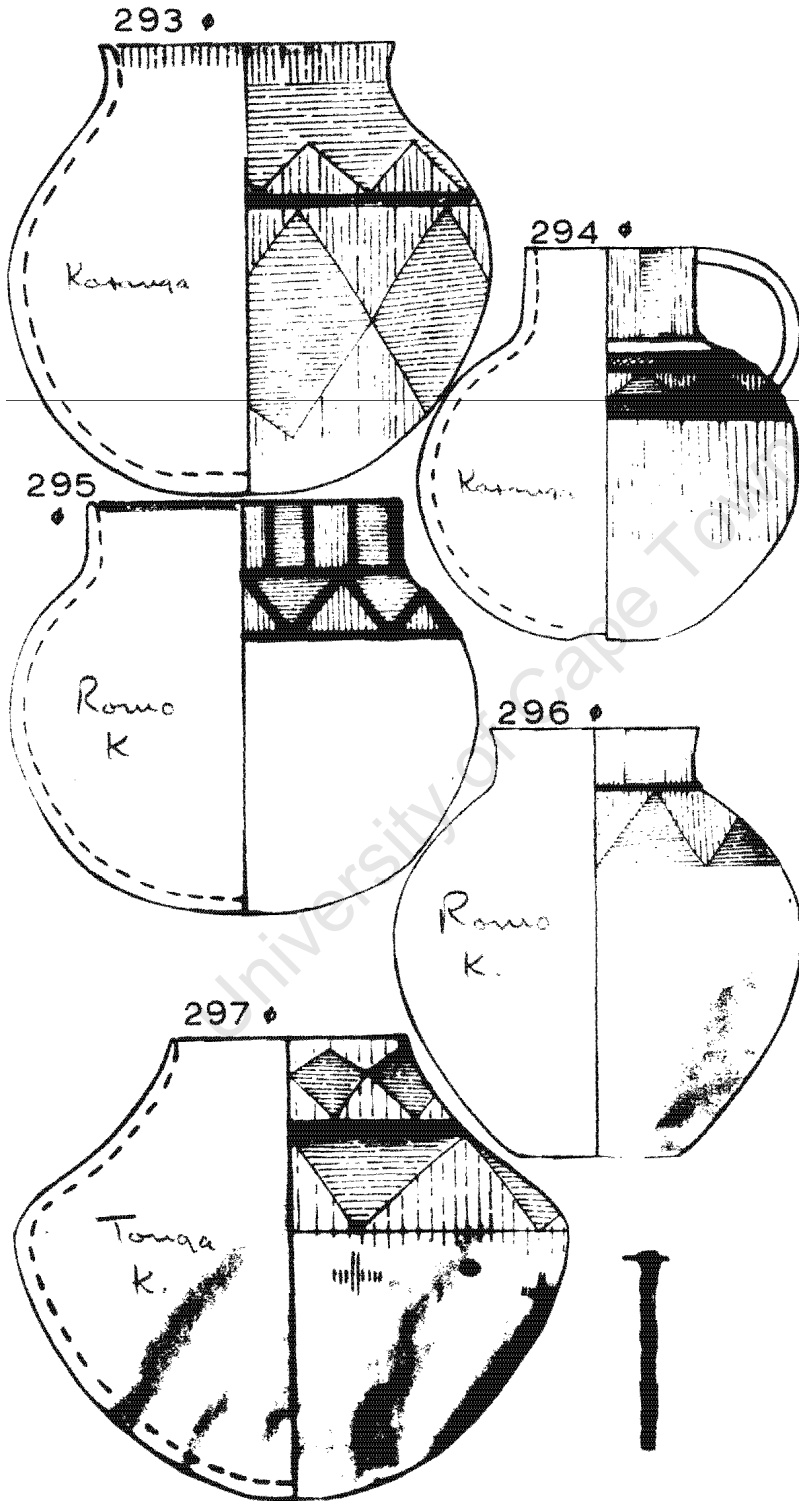
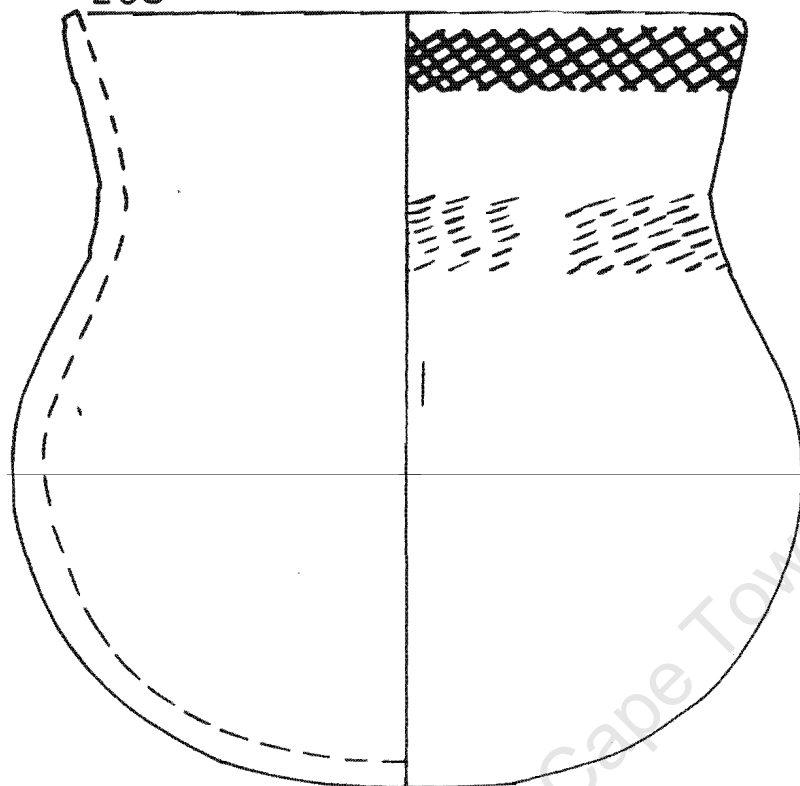
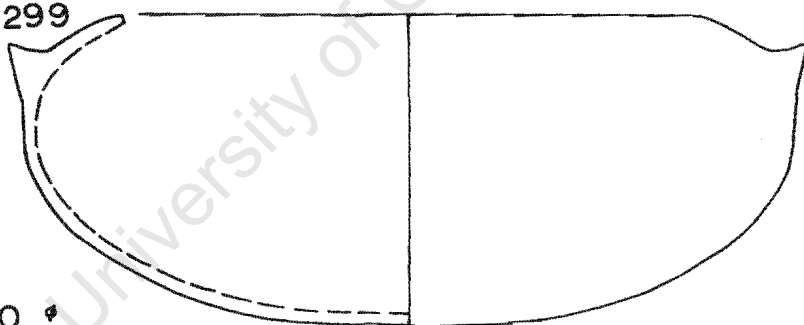

Figure LXVI

298



299



300

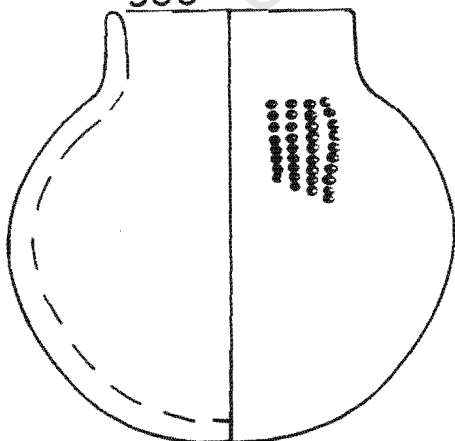

301



302

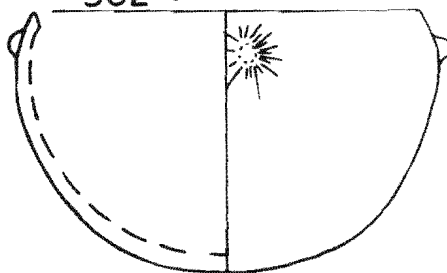

Figure LXVII

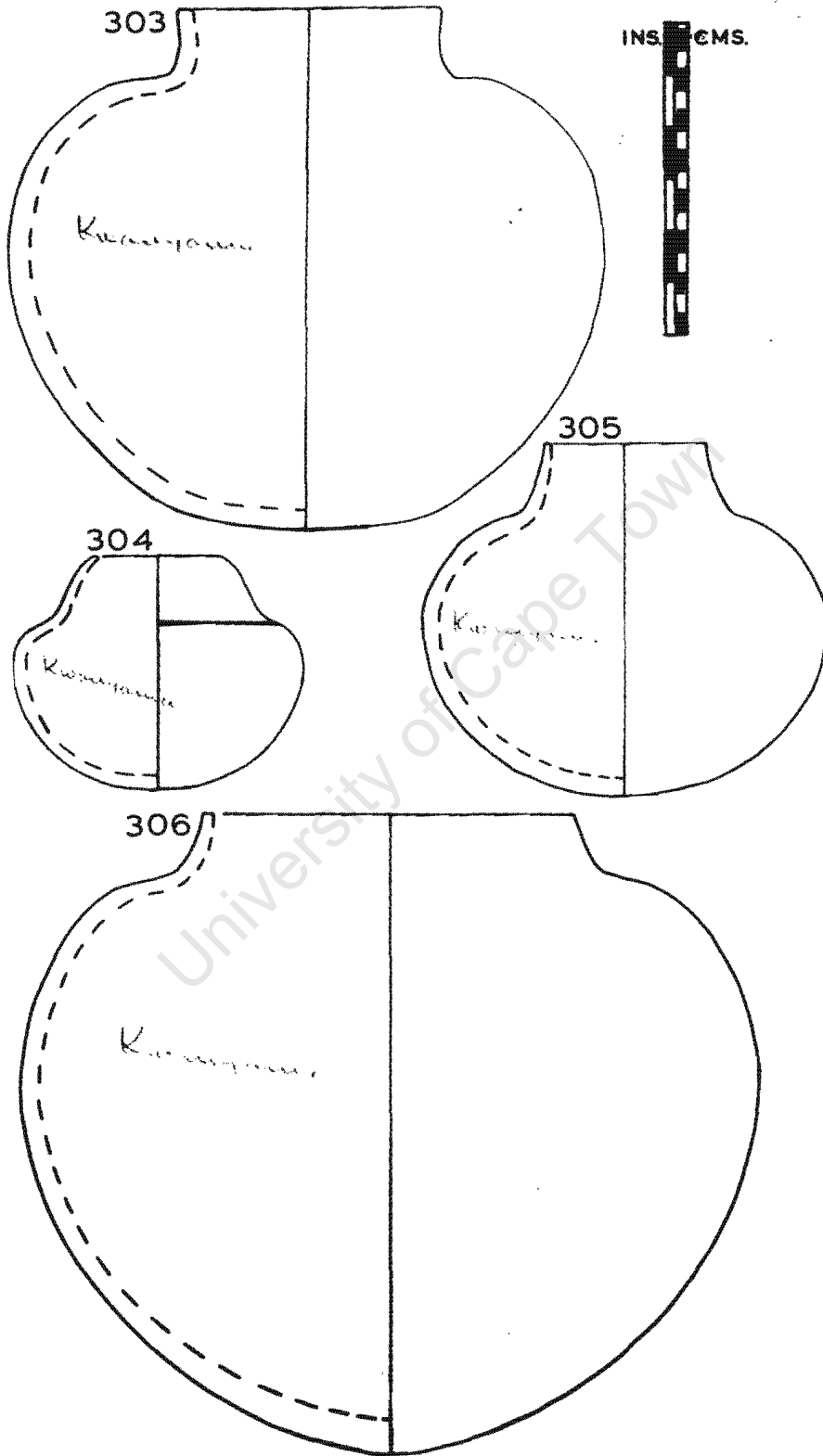

Figure LXVIII

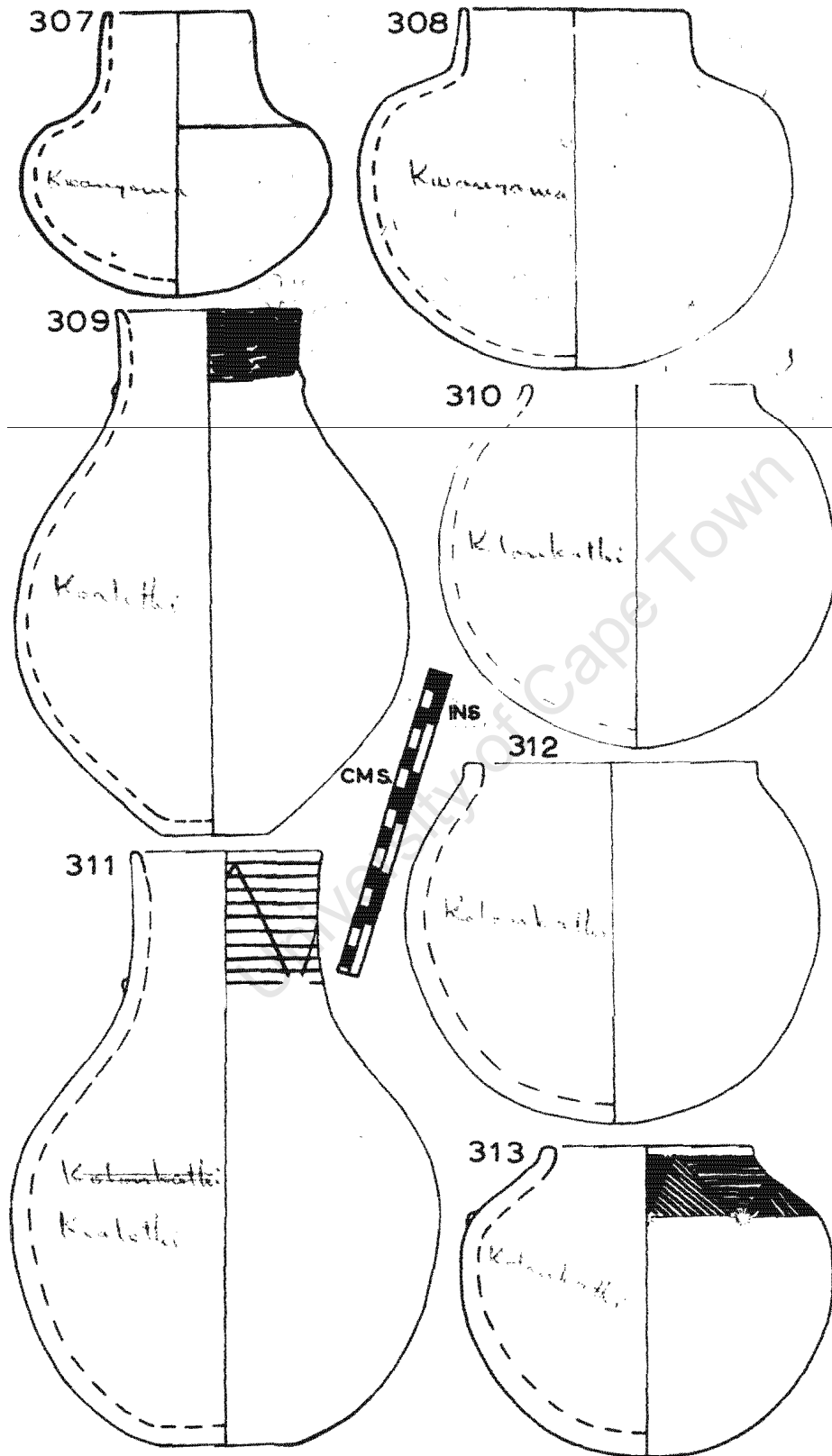
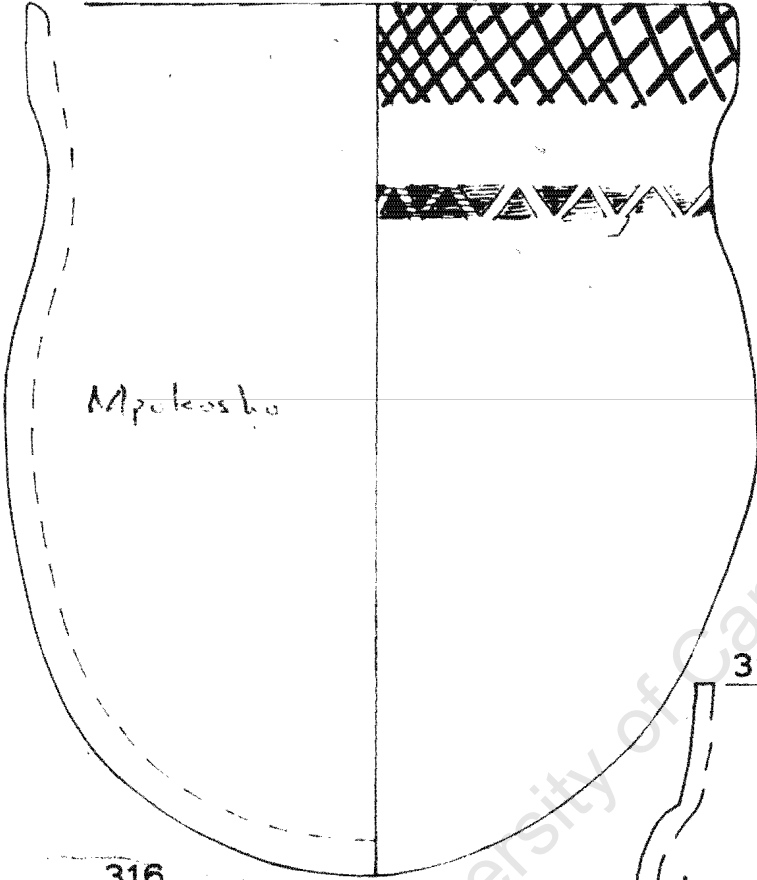

Figure LXIX

Eastern Auro

314 ♀

MFOKESHO



Mpokesho

CMS. INS.



315

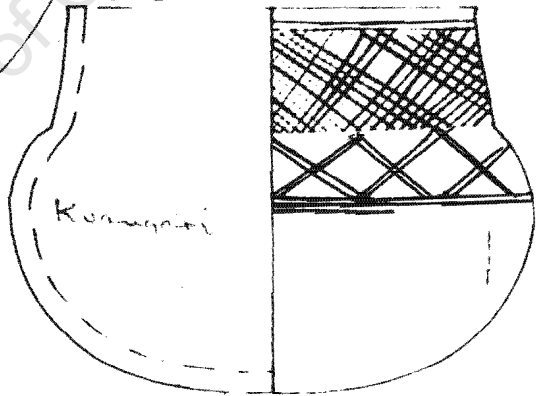

Komanti

316

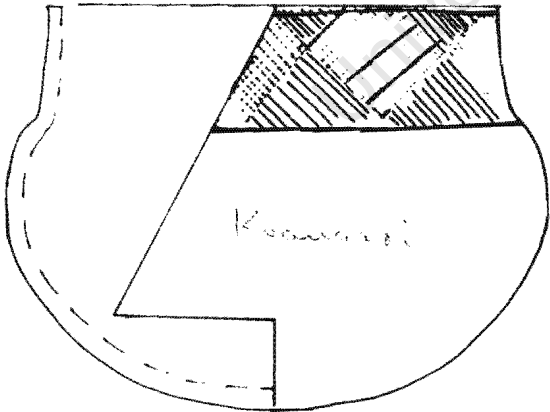

Komanti

317

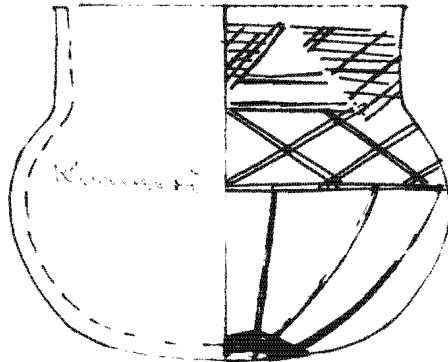

Komanti

Figure LXX

? Diriko

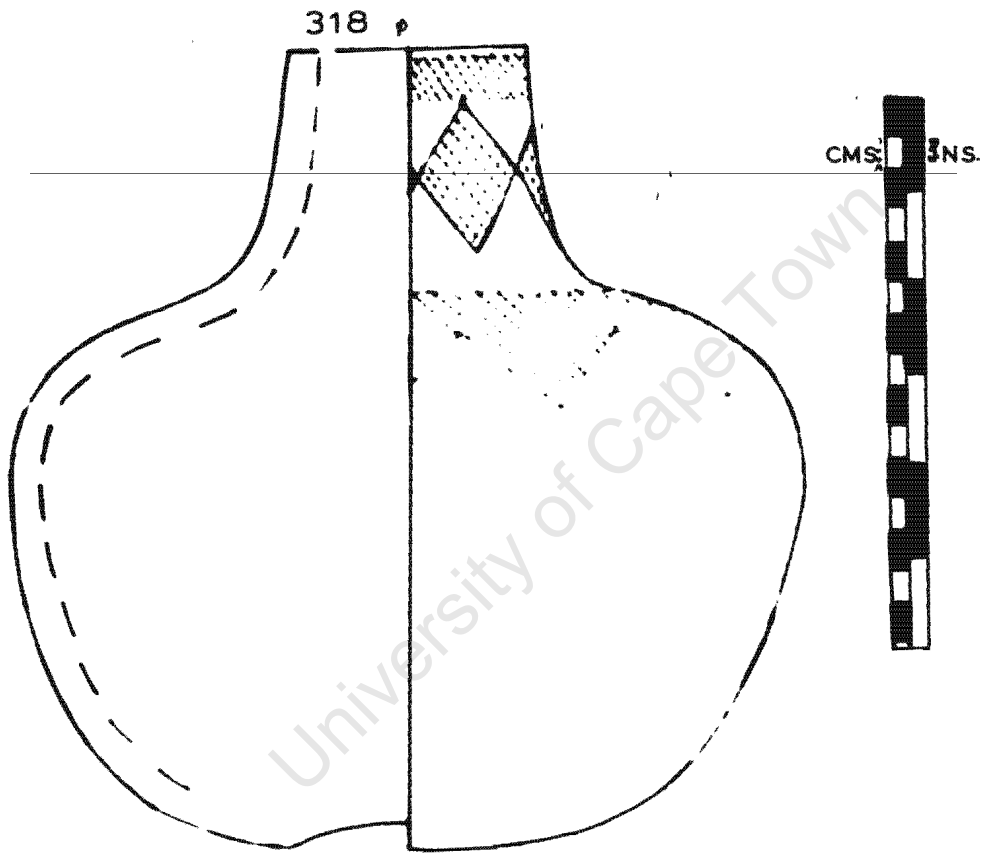

Figure LXXI

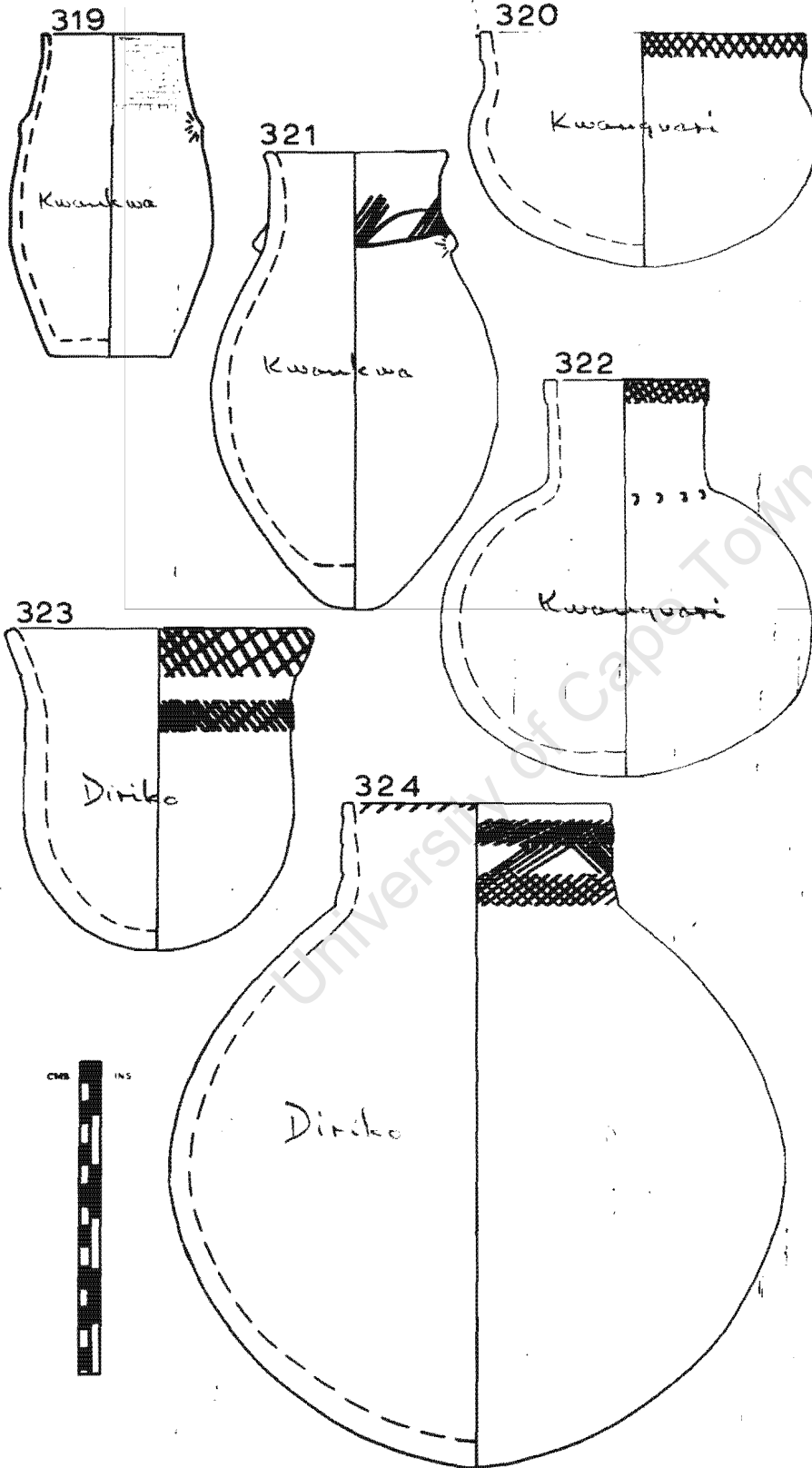

Figure LXXII

Apokusho

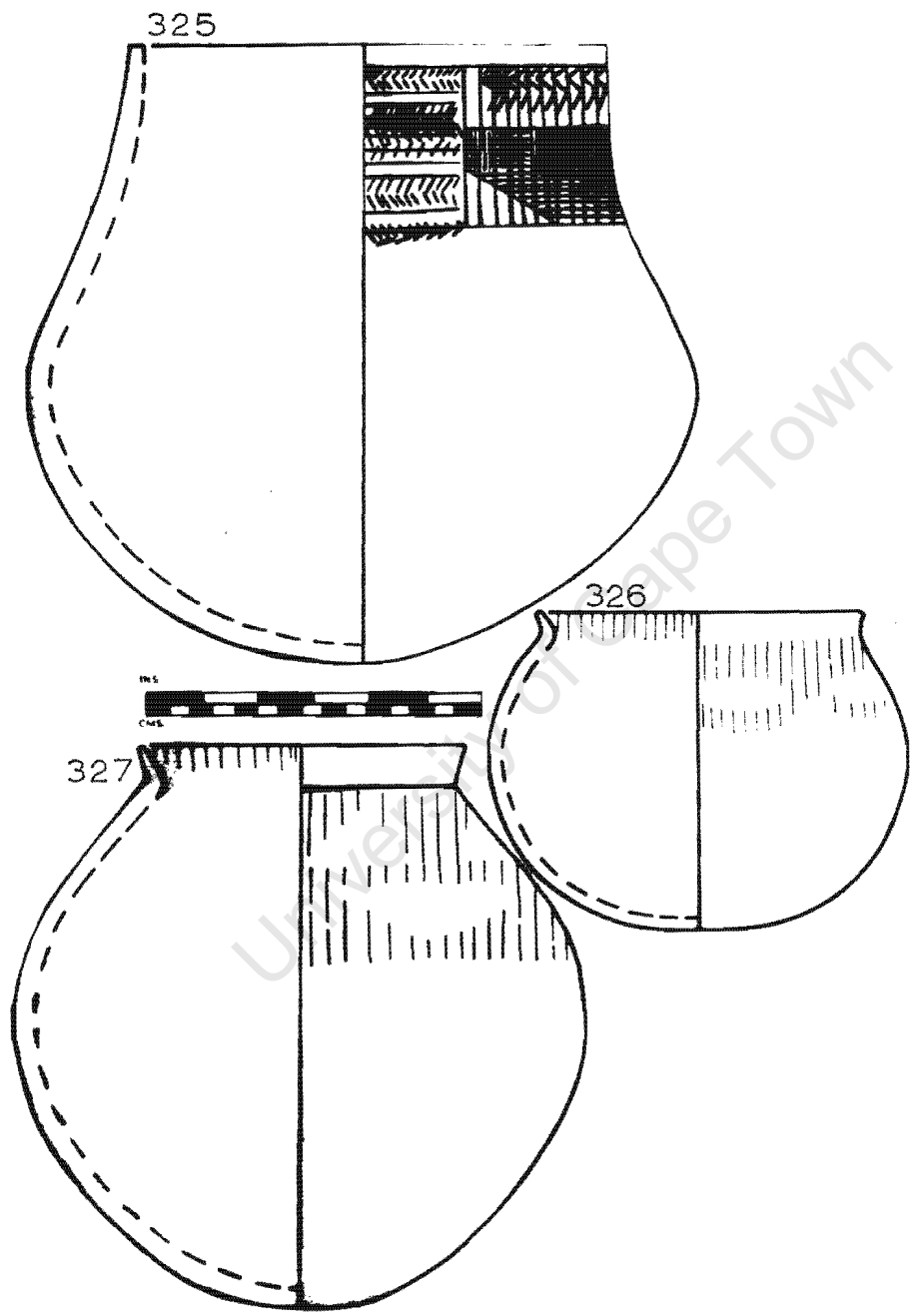

Figure LXXIII

С. К. А. Д. Н. К. С. Т. Е. Р. А.
М. П. К. о. с. т. о. в.

328

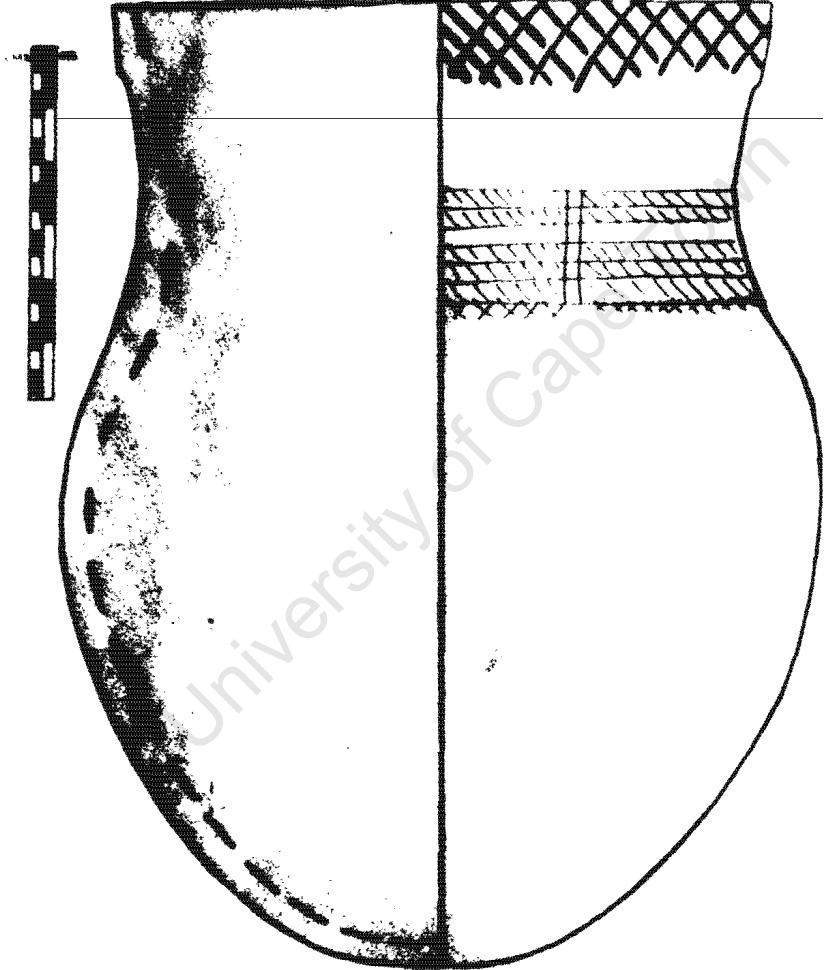

Figure LXXIV

Herero

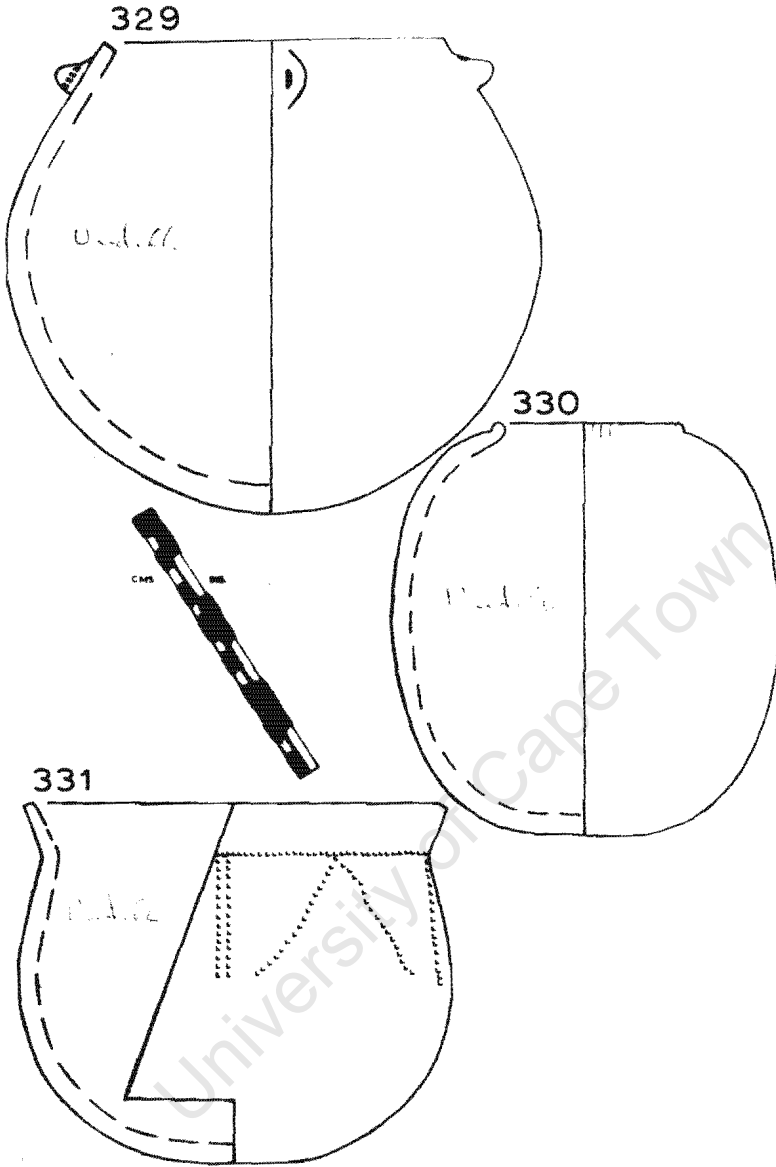

Figure LXXV

BOMVANA



NO.1 BOMVANA Nkanye, Elliotdale, Transkei. ingayi



NO.2 BOMVANA I. T.M. 35/380 H.32cms. mpanda ondgwe
r. T.M. 35/359 H. 40cms.

MPONDO



NO. 3 MPONDO I. T.M. 35/439 Lusikisiki, Transkei H. 13 cms.
c. T.M. 35/425 H. 18 cms r. T.M. 35/428 Lusikisiki, Transkei H. 19 cms.
All ingayi



NO. 4 MPONDO Qawukeni, Transkei I. H. 62 cms. r. 58 cms.
Both imbiza.

MPONDO

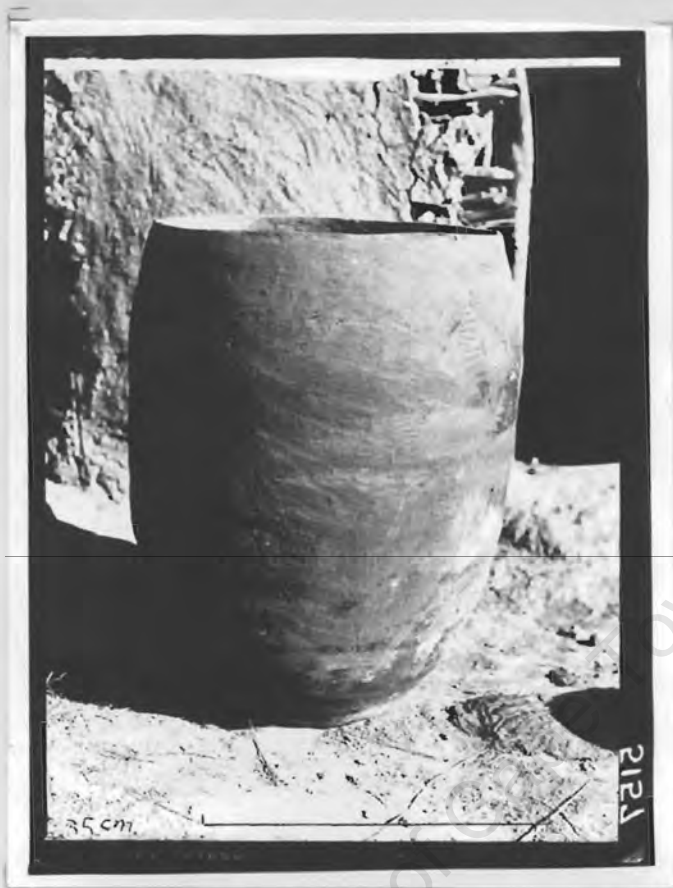

NO 5 MPONDO Luqhoqweni, Lusikisiki, Transkei.
H. 55 cms. ikhanzi



NO. 6 MPONDO Luqhoqweni, Lusikisiki, Transkei.

MPONDO



NO. 7 MPONDO E.L. 740 H. 44 cms.



NO. 8 MPONDO E.L. 748 H. 33 cms.

XESIBE



NO. 9 XESIBE Eubaleko, Mount Ayliff, Transkei
umphandg



NO. 10 XESIBE EL. 980 H. 42 cms. grain store

XESIBE



NO.11 XESIBE Eubaleko, Mount Ayliff, Transkei
l. H. 17cms. ukhamba r. H. 25 cms. ingcaza

NATAL NGUNI AND SWAZI



NO.12 MABASO SAM. 8432
Msinga Natal H. 51 cms. imbiza



NO.13. SWAZI Emoweni, Hlatikulu, Swaziland



NO.14 SWAZI Hlatikulu, Swaziland. I. imbiza
r. ludiwo

SWAZI



NO. 15 SWAZI SAM. 8656 Abercorn road, Stegi, Swaziland.



NO. 16 SWAZI Abercorn road, Stegi, Swaziland.

RONGA

Moulding from the lump:



NO.20 Starting to hollow conical lump



NO.21 Smoothing inside vessel



NO.22 Forming the carination

RONGA (continued)



NO. 23 Scraping out inside.



NO. 24 Decorating with shell.



NO. 25 Finishing off the rim.

Ring technique:



NO. 26 Preparing wall for ring



NO. 27 Adding ring



NO. 28 Smoothing and shaping



NO. 29

Smoothing



NO. 30

The completed vessel



NO. 31

Grinding ochre

NKUNA (continued)

TSWA



NO. 32 TSWA Panda, Mozambique. Potter shaping vessel.



NO 33 BiThonga pot made at Mutamba near Maxixe, Mozambique - used by TSWA near Funhalouro.

Firing:



NO. 37 Putting small pot in position



NO. 38 Building hearth wall.



NO. 39 Covering with dry dung.



NO. 40 Removing fired pots.

TLOKWA

Building from the widest diameter:



NO. 45 The start.



NO. 46 Smoothing the wall up.



NO. 47 The shaped upper-section.



NO. 48 Vessel turned over after drying.

T LOKWA (continued)



NO. 49 Smoothing.



NO. 50 Making an additional roll



NO 51 Closing base with roll



NO. 52 Completed pot

VENDA AND LEMBA



NO. 57 LEMBA SAM. 8689 Mphego's Location, Sibasa, N. Transvaal H. 37 cms.



NO. 58 VENDA Mphego's Location, Sibasa, Northern Transvaal. Cooking pot with lid.



NO. 59 VENDA Nesengani's place, Sibasa, N. Transvaal. Pots used as peanut stores.



NO. 60 LEMBA Mphego's Location, Sibasa, N. Transvaal. Preparing the clay.

LEMBA

Moulding from the lump:



NO. 61 Hollowing the lump.



NO. 62 Shaping the rim.



NO. 63 Incising an horizontal line.



NO. 64 Stamped line.

BITHONGA AND SHONA



NO. 65 BITHONGA SAM. 8920 Jangamo, Inhambane, Mozambique. H. 35 cms. nghulu



NO. 66 BITHONGA SAM. 8919 Jangamo, Inhambane, Mozambique. H. 21 cms. kalango



NO. 67. MANYIKA Inyanga, Rhodesia. Beerpot.



NO. 68 MANYIKA Inyanga, Rhodesia. Same with lid.

SHONA, KWANYAMA AND MPUKUSHU



NO. 73 KARANGA S.A.M. 8982
Belingwe, Rhodesia. H. 46 cms.



NO. 74 NDAU Tanganda Halt,
Chipinga, Rhodesia. Starting a pot.



NO. 75 KWANYAMA near Saint Mary's
Mission, Odibo, South West Africa.
Underground workroom.



NO. 76 MPUKUSHU S.A.M. 9008
Okavango, South West Africa.
H. 38 cms. kandimbe.

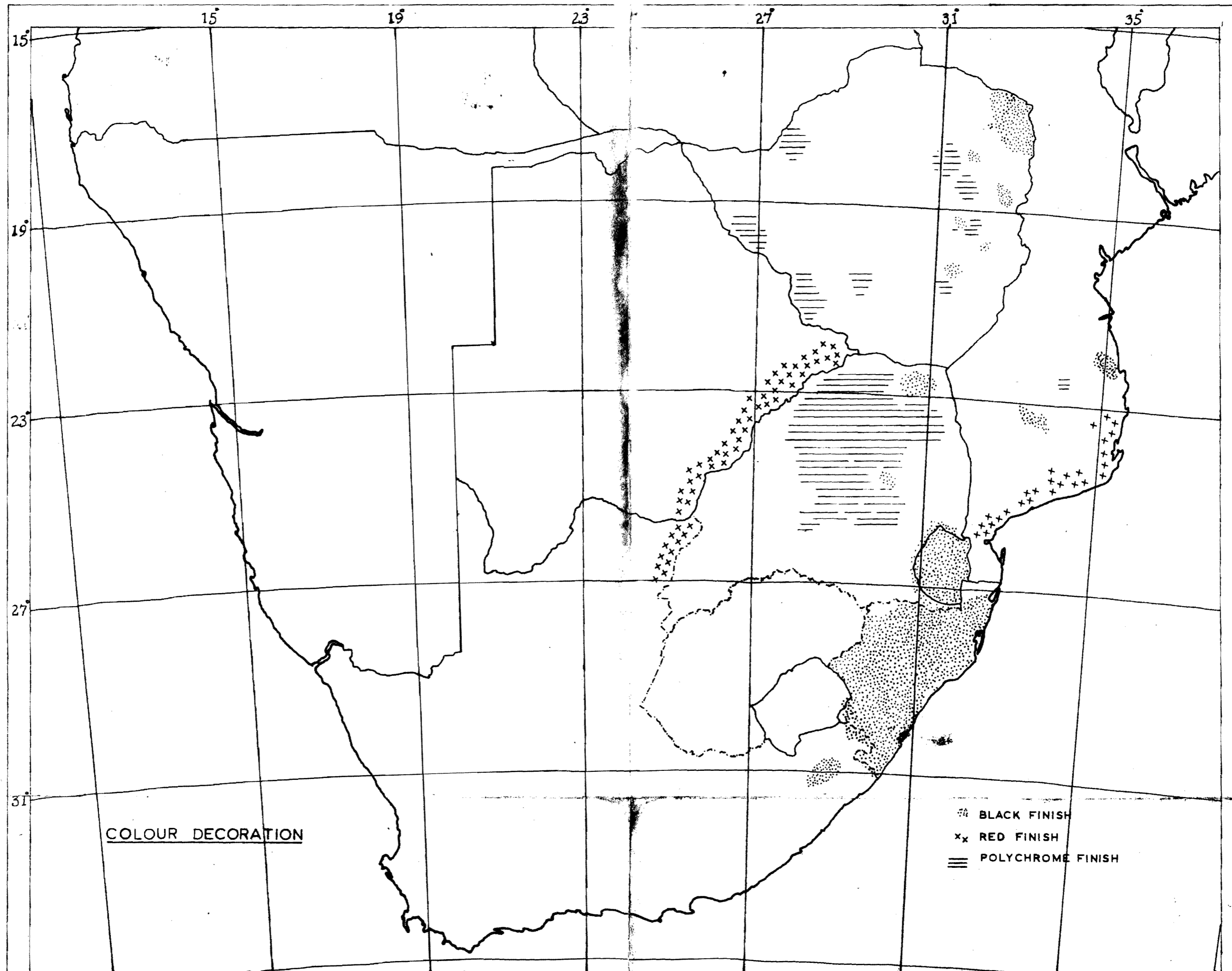

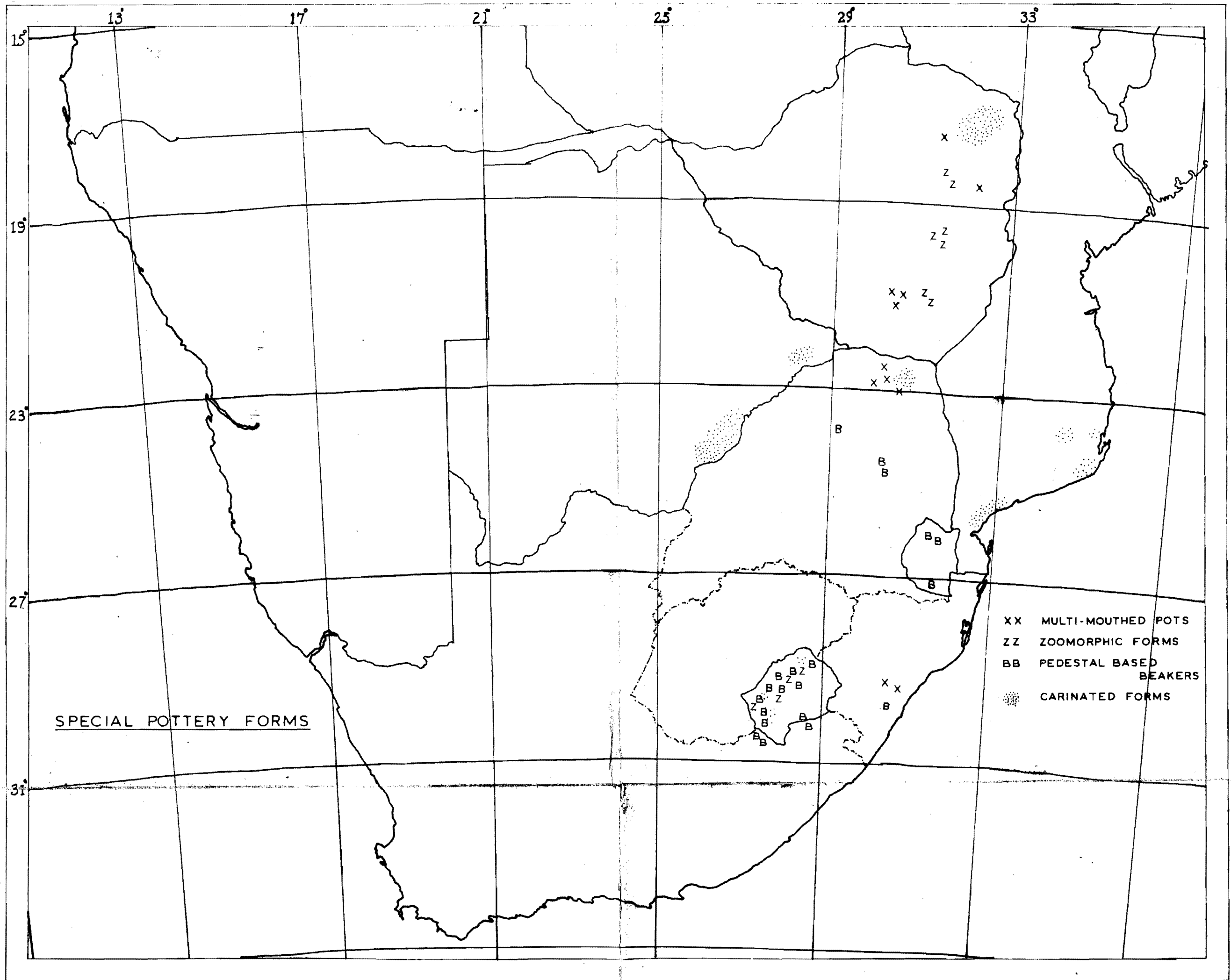

SPECIAL POTTERY FORMS

- XX MULTI-MOUTHED POTS
- ZZ ZOOMORPHIC FORMS
- BB PEDESTAL BASED BEAKERS
- CARINATED FORMS

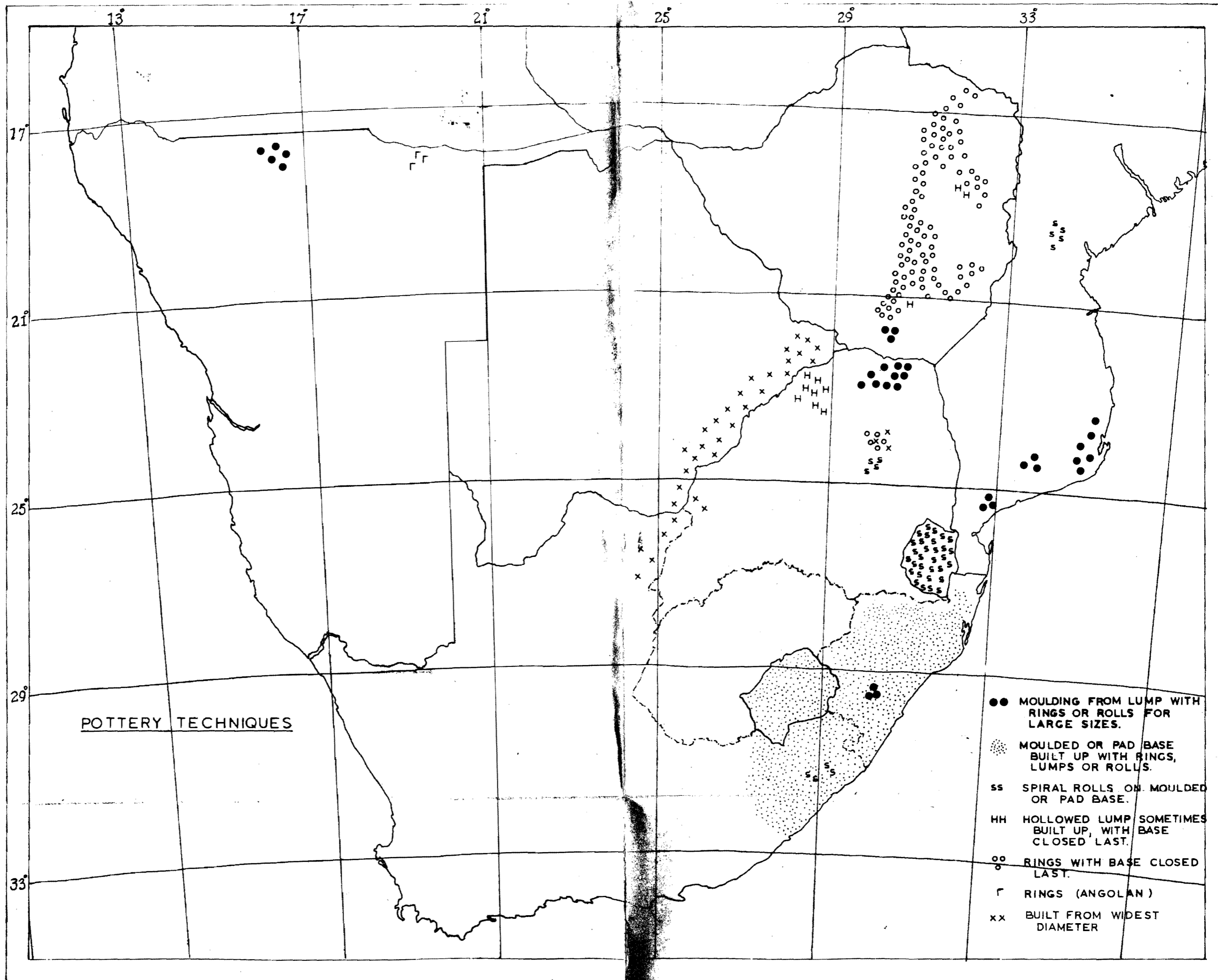

POTTERY TECHNIQUES

- MOULDING FROM LUMP WITH RINGS OR ROLLS FOR LARGE SIZES.
- ⊙ MOULDED OR PAD BASE BUILT UP WITH RINGS, LUMPS OR ROLLS.
- ss SPIRAL ROLLS ON MOULDED OR PAD BASE.
- hh HOLLOWED LUMP SOMETIMES BUILT UP, WITH BASE CLOSED LAST.
- oo RINGS WITH BASE CLOSED LAST.
- r RINGS (ANGOLAN)
- xx BUILT FROM WIDEST DIAMETER



FIELD TRIPS

MUSEUM TRANSPORT

- xxxxx ZULULAND AND TRANSKEI
May 1961
- xxxxxxx HERSCHEL DISTRICT
November 1961
- BASUTOLAND
February 1962
- ~~~~~ SWAZILAND AND TRANSVAAL
June 1962
- xxxxxxx BECHUANALAND AND MOZAMBIQUE
September 1962
- MOZAMBIQUE AND RHODESIA
June-July 1963

AIR TRAVEL

- SOUTH WEST AFRICA
August 1961
- BASUTOLAND
February 1962

PUBLIC TRANSPORT

- OVAMBOLAND
August 1961

AMBO

N. Ambo
zzz kwanyama & ndombondola

S. Ambo
□ □ ondonga
■ ■ kualuthi
■ ■ kuambi
■ ■ ongandjera
■ ■ ombalantu
■ ■ eunda

E. Ambo
● ● kuangari
□ □ bunja

OKAVANGO TRIBES

^ ^ Mpukushu
† † Sambiu
Y Y Diriko

SHONA

Roswi
3 roswi
1 shangwe
2 nohwe
duma
ndau

Karanga
chikunda
tonga
korekore
tawara
zezuru
manyika
govera
budjga
mari
karanga
ungwe
bangwe
teve

VENDA AND LEMBA

Venda
Lemba

CHOPI

Lenge
Chopi
Khoka

TSONGA

Ronga
Nhlanganu
Tshangana
Nkuna
N. Tsonga
1 nwalungu
2 hlungwe
3 tswa

C. Tsonga
1 nwanati & khambana
2 khosa
3 hlavi

SOTHO

XXX S. Sotho
X X X
++++ W. Tswana
vvvv E. Tswana
>>>> N.E. Sotho
AAAAA C. Sotho
<<<<< E. Sotho
xxxxx N. Sotho

NGUNI

Cape Nguni
1 xhosa
2 thembu
3 bomvana
4 mpondomisi
5 mpondo
6 gcaleka

Immigrant Cape Nguni
7 fingo
8 hlubi
9 bhaca
10 xesibe

Natal Nguni

zulu & others

Swazi

ngwane & others

S. Tvl. Ndebele

manala & others

Ni. Tvl. Ndebele

moletiane & others

Rhodesian Ndebele

matabele

HERERO
Kaokoveld Herero
Damaraland Herero
Bechuanaland Herero

THE BANTU TRIBES OF SOUTHERN AFRICA

