

THE GENESIS OF
THE BLUE AMPHIBOLE ASBESTOS
OF THE
UNION OF SOUTH AFRICA

by
J.H.GENIS

Thesis submitted in fulfilment of
the requirements for the degree

of

DOCTOR OF PHILOSOPHY

in the
Faculty of Science

of the

UNIVERSITY OF CAPE TOWN

The University of Cape Town has been given
the right to reproduce this thesis in whole
or in part. Copyright is held by the author.

April, 1961.

The copyright of this thesis vests in the author. No quotation from it or information derived from it is to be published without full acknowledgement of the source. The thesis is to be used for private study or non-commercial research purposes only.

Published by the University of Cape Town (UCT) in terms of the non-exclusive license granted to UCT by the author.

ABSTRACT

The blue amphibole asbestos, crocidolite, which occurs as interbedded seams in banded ironstones of the Lower Griquatown Stage of the Transvaal System in the Northern Cape Province, is the finely fibrous form of the soda-amphibole riebeckite. Despite the widespread occurrence of the Precambrian type of banded ironstones, crocidolite is a mineral of rare occurrence and is only developed to a relatively minor extent in South Africa, Western Australia and Central China.

The composition, structure and properties of riebeckite in general and of crocidolite in particular are discussed and four new chemical analyses are given. Particular attention is paid to the mode of occurrence of fibrous riebeckite and it is suggested that the name "crocidolite" be reserved for the asbestiform riebeckite which occurs interbedded with banded ironstones.

The general geology, lithology and mineralogy of Precambrian banded ironstones are described and their distribution in space and time is discussed. It is found that no banded ironstones are known to be younger than 1000 million years. This fact is related to special conditions of atmosphere, surface temperature and biological development which existed during the so-called Primitive Period of the Precambrian, a period which lasted from approximately 3000 million years to 1000 million years ago.

The banded ironstones of the Transvaal System are described in some detail and seven new chemical analyses as well as trace element data are given.

The genesis of banded ironstones is discussed at some length and particular attention is paid to the authigenesis of riebeckite. It is concluded that banded ironstones were deposited in seasonally fluctuating, typically "non-aggressive", fresh to brackish water lakes which were fed by sluggish, mature rivers. The solutions of iron and silica, alkaline earths and clay colloids carried by these rivers were derived from basic igneous rocks by chemical weathering in a tropical, monsoon-type climate. Recognisable detrital material is virtually absent from the banded ironstones of the Transvaal System, but it is thought that the stilpnomelane layers are aeolian deposits and that their composition gives some indication of the material which remained behind as "lateritic" soils in the source area. It is suggested that both crocidolite and riebeckite were formed by the low temperature dehydration, in situ, of an ordered precursor which could have been a clay mineral similar in structure to attapulgite, but containing ferrous and ferric ions in the octahedral layer. This clay mineral acquired sodium by cation exchange during dry periods when the depositional lakes were enriched in sodium.

It is found that the actual formation of crocidolite is completely unrelated to dynamic stress. It formed only where layers of proto-riebeckite were in close contact or traversed by magnetite layers. It grew by the diffusion of proto-riebeckite through the magnetite layers, its transformation to riebeckite during its passage, and final addition to fibre growth points in contact with the magnetite layer. This process was initiated by slight temperature gradients in the magnetite layers and was propagated by a type of thermal autocatalysis. The temperature gradients in the magnetite layers resulted from their superior heat conductivity combined with differences in depth of burial of the strata. Economic deposits of crocidolite formed where a sufficient number of layers of proto-riebeckite were in contact with magnetite layers which maintained or repeatedly attained the requisite temperature levels. The superimposed economic deposits of the Kuruman area, which appear to be related to folding, are due to an early period of folding, possibly even slumping during deposition, which took place prior to the formation of crocidolite and caused the thickening of the proto-riebeckite layers in the crests and troughs of folds by plastic flow from the flanks.

Three appendices, giving details of chemical and spectrographic analyses and of chemical experiments carried out, are attached.

CONTENTS

I.	<u>INTRODUCTION</u>	1
II.	<u>THE COMPOSITION, STRUCTURE AND PROPERTIES OF RIEBECKITE.</u>	2
	(a) Composition	2
	(b) Structure	10
	(c) Physical properties	13
	(d) Intergrowths of riebeckite with grunerite	15
III.	<u>THE MODE OF OCCURRENCE OF FIBROUS RIEBECKITE</u>	16
	(a) Tufts and spherulites of fibrous riebeckite	16
	(b) Veins or seams of cross-fibre riebeckite	21
	Transgressive veins of cross-fibre riebeckite ...	21
	Conformably seams of crocidolite	22
	Sporadic occurrence of crocidolite	26
	Relation of crocidolite to folding	27
	Morphological features of the crocidolite seams..	28
	The magnetite screens	30
	Impurities within the seams	31
	Inclined and kinked fibres	33
	Weathering and Silicification	35
IV.	<u>PRECAMBRIAN BANDED IRONSTONES</u>	38
	(a) The term "banded ironstone"	38
	(b) General geology of banded ironstones	38
	(c) Lithology and mineralogy of banded ironstones	39
	1. The fresh rocks	39
	2. Weathering and silicification	43
	3. Sedimentary facies of banded ironstones	44
	4. Metamorphism of banded ironstones	45
	(d) Distribution in space and time	47

IV.	(Contd.)	
	(e)	South African banded ironstones 49
	1.	Distribution and correlation 49
		The "older" banded ironstones 49
		Banded ironstones in the Lower Witwatersrand System 51
		Banded ironstones in the Transvaal System 51
V.	<u>THE BANDED IRONSTONES OF THE TRANSVAAL SYSTEM</u>	52
	(a)	General Geology of the Transvaal System 52
	(b)	Petrography of the Lower Griquatown Stage 56
	1.	The Banded Ironstone Zone 57
	2.	The Jasper or Mudstone Zone 63
	3.	The Glacial Zone 65
	(c)	The Banded Ironstone Zone in the Transvaal 66
	(d)	Chemistry of the Banded Ironstone Zone 67
	(e)	Structure and folding 71
	(f)	Igneous activity 73
	(g)	Metamorphism 74
VI.	<u>THE GENESIS OF THE PRECAMBRIAN BANDED IRONSTONES</u>	78
	(a)	Distribution in time 78
		The nature of the earth's Precambrian atmosphere 79
		(i) A residual atmosphere 79
		(ii) A slowly accumulating atmosphere 80
		The evolution of the oceans 81
		The oxygen content of the Precambrian atmosphere 82
		The start of photosynthesis 84
		The origin of photosynthesising plants 86
		Proposed sub-divisions of the Precambrian Era. 87

VI.	(Contd.)	
	(b)	Mode of formation 88
	1.	The nature of the source rocks 89
	2.	Topography and weathering of the source area 91
	3.	Mode of transportation 95
		(i) Solution and transportation of iron and silica 95
		(ii) Solution and transportation of other constituents of banded ironstones 96
	4.	Pattern of environments in the depositional area. 97
		(i) Fresh water vs. marine depositional environment 97
		(ii) Precipitation of iron and silica 98
		(iii) Deposition of other constituents of banded ironstones 103
		(iv) Sedimentary facies of banded ironstones 104
		(v) Pattern of environments in the Transvaal System depositional area, with special reference to the Lower Griquatown Stage..... 105
	5.	Distribution of tectonic elements over the depositional and source areas 108
	6.	Post-depositional changes 109
VII.	<u>THE GENESIS OF RIEBECKITE</u> 111
	The authigenesis of riebeckite 113
VIII.	<u>THE FORMATION OF CROCIDOLITE</u> 120
	(a)	A proposed theory of crocidolite formation 123
	(b)	The formation of economic crocidolite deposits 127
	(c)	Association of crocidolite and amosite in the Transvaal 128

<u>CONCLUSIONS</u>	131
(a) The genesis of Precambrian banded ironstones	131
(b) The genesis of riebeckite	132
(c) The formation of crocidolite	133
 <u>ACKNOWLEDGMENTS</u>	 135
 <u>REFERENCES</u>	 136
 <u>APPENDIX NO.1</u>	
Details of chemical and spectrographic analyses	xii
(a) Preparation of samples	xii
(b) Chemical analyses	xii
(c) Spectrographic analyses	xv
1. Determination of the alkali elements	xv
2. Involatile elements	xvi
 <u>APPENDIX NO.2</u>	
Experiments at elevated temperatures and pressures	xvii
 <u>APPENDIX NO.3</u>	
Experiments on the crystallisation of copper sulphate ...	xix

LIST OF PLATES

FRONTISPIECE.	Competent behaviour of crocidolite	1
I.	The distribution of the Transvaal System in the Northern Cape Province	attached
II.	Association of riebeckite with grunerite	15
III.	A. Fibrous riebeckite tufts	
	B. Discrete spherulites of fibrous riebeckite ...	
	C. Spherulitic texture of mass-fibre riebeckite	16
IV.	A. Globules of fibrous riebeckite in carbonatite ...	
	B. Riebeckite in carbonatite ...	
	C. Globular spherulites of copper sulphate	19
V.	Transgressive vein of cross-fibre riebeckite	21
VI.	Outcrop of riebeckite-bearing bed, Prieska district .	22
VII.	Stilpnomelane layer (boornaat) in crocidolite reef ..	25
VIII.	A. Small isoclinal fold	
	B. Small scale nappé structure	27
IX.	A. Convoluted surface of crocidolite seam ...	
	B. Fold cut off by crocidolite seam	29
X.	Section of crocidolite seams showing various morphological features	29
XI.	A. Relationship of fibre length to magnetite screen thickness ...	
	B. Recrystallised fibre and magnetite screen	30
XII.	A. Partial replacement of crocidolite by quartz ...	
	B. Crocidolite - amosite doublet	31
XIII.	Post induration folding of a crocidolite seam	35
XIV.	A. Carbonate rhomb overgrowths	
	B. Fibrous riebeckite crystallised preferentially on carbonate	
	C. Dendritic growth of riebeckite from surface of carbonate rhomb	59

XV.	A.	Magnetite layers in chert-minnesotaite rock ...	
	B.	Veins of recrystallised, cross-fibre stilpnomelane in micro-bedded stilpnomelane	59
XVI.		Rod-like carbon particles in stilpnomelane	61
XVII.	A.	Granular carbonate layers showing stylolitic intergrowth set in banded chert-minnesotaite rock.	
	B.	Intraformational chert breccia	61
XVIII.		Small scale isoclinal overfolds in mixed amosite- crocidolite reef	66
XIX.	A.	Partly recrystallised riebeckite in crocidolite seam ...	
	B.	Orientation of recrystallised minerals in banded ironstone	66
XX.		Cummingtonite slate	66
XXI.		Disharmonic folding in banded ironstone	72
XXII.		Aerial view of banded ironstone hills showing declivities formed over dykes	74
XXIII.		Chemically rounded magnetite crystals set in fibrous quartz	75
XXIV.		Movement of magnetite crystals ahead of growing fibres	124
XXV.		Break in magnetite screen caused by the rapid growth of fibres at adjacent points	124
XXVI.	A.	Control of fibre orientation exerted by magnetite on interstitial or immediately adjacent riebeckite	
	B.	Control of fibre orientation by magnetite surfaces	126
XXVII.	A.	Copper sulphate fibres	
	B.	Copper sulphate dendrites growing from an initiating surface	
	C.	Mass-fibre copper sulphate	xix

LIST OF TEXT FIGURES

1. Diagrammatic representation of the amphibole structure showing the lattice positions and the cations normally occupying them (Boyd, 1959, p.378)	2
2. The structure of riebeckite (Whittaker, 1949)	11
3. The development of a fibrous spherulite by fringing dendritic growth from a central nucleus	16
4. Flow of heat during A. cellular and B. dendritic growth ..	17
5. Inter-reef concentration of crocidolite at Warrendale Mine, near Danielskuil	23
6. Sketch illustrating the various attitudes assumed by crocidolite fibres	33
7. Rib-like crenulations on minnesotaite flakes	58
8. Diagram showing how a rounded section is derived by progressive removal of octahedral planes	75
9. Cycles of iron deposition after Sakamoto (1950, p.468) ...	100
10. Stability field of riebeckite (Ernst, 1960)	114
11. Structural schemes of attapulgite and riebeckite	117
12. Schematic diagram showing the movement of the magnetite screen during fibre growth	125
13. The growth of copper sulphate through a porous pot	xx

LIST OF TABLES

1. Chemical analyses of fibrous riebeckite	5
2. Empirical formulae for analyses in Table No.1	8
3. Sodium content of crocidolite	9
4. Crocidolite Horizons in the Cape and Transvaal Provinces .	24
5. Principal features of banded ironstone facies	45
6. Metamorphic changes in banded ironstones	46
7. Stratigraphic columns of the Transvaal System	55
8. Chemical analyses of banded ironstones	68
9. Trace element distribution in banded ironstones	69

I. INTRODUCTION

The blue amphibole asbestos which occurs associated with banded ferruginous sediments in the northern part of the Cape Province of the Union of South Africa is a finely fibrous form of the soda-amphibole, riebeckite. The occurrence was first recorded in 1803 by Lichtenstein, who called it "Blau Eisenstein" because of its vivid blue colour. In 1831, Stromeyer and Hausmann suggested its present-day name of "crocidolite", meaning "woolly stone". The name "crocidolite" has since been used to describe all fibrous forms of riebeckite, irrespective of mode of occurrence or origin. It is suggested that the name "crocidolite" be strictly reserved to describe the commercial variety of cross-fibre, riebeckite asbestos, which occurs in association with banded ferruginous sediments. All other modifications of riebeckite should be referred to as "riebeckite" with qualifying adjectives such as "asbestiform", "fibrous", "needle", "asteriated", etc., where necessary. The above definitions have been accepted for the purpose of this thesis.

Crocidolite has been mined in the Cape Province since 1893. Similar deposits have since been discovered and exploited in the Transvaal, Western Australia and Central China. Despite the widespread occurrence of banded ferruginous sediments, crocidolite is of rare occurrence and is only developed to a relatively minor extent in South Africa, Western Australia and Central China.

The writer had the opportunity to map and study a number of crocidolite-producing mines, as well as undeveloped properties, during the course of a prospecting programme in the Cape Asbestos Fields. The striking feature about all the properties examined is the continuity of the riebeckite-bearing beds in contrast to the sporadic occurrence of economically important concentrations of crocidolite within these beds. This thesis is an attempt to explain some of the problems connected with the genesis of crocidolite, problems such as its chemical variation, sporadic occurrence and mode of formation.

II. THE COMPOSITION, STRUCTURE AND PROPERTIES OF RIEBECKITE

(a) Composition

Chemical variation in the natural amphiboles can be represented by the formula:-

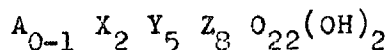

in which the letters A, X, Y and Z represent cations in definite lattice positions. These lattice positions and the cations normally occupying them are shown in Fig. 1 below:-

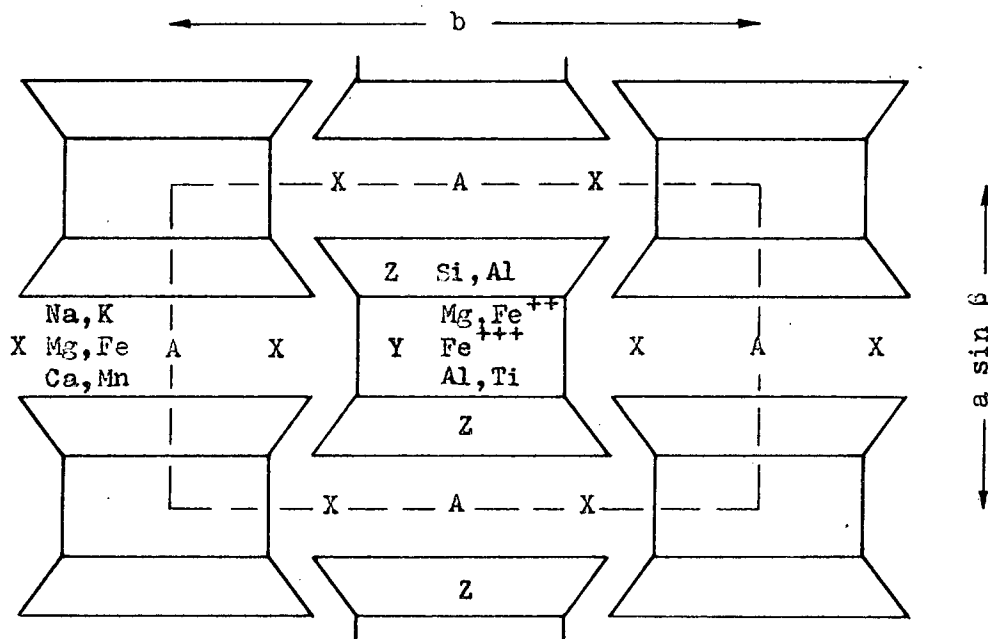

Fig.1. Diagrammatic representation of the amphibole structure showing the lattice positions and the cations normally occupying them (Boyd, 1959, p.378).

Boyd (1959, p.379) subdivided the natural amphiboles into three groups on the basis of the cations occupying the "X" position.

These groups are:-

1. The Anthophyllite - Cumingtonite group, with "X" = Mg or Fe⁺⁺,
2. The Calciferous group, with "X" = Ca, and
3. The Alkali group, with "X" = Na.

Miyashiro (1957) further subdivided the Alkali amphibole group into four sub-groups on the basis of the degrees of (Na,K)⁺ + R⁺⁺ for R⁺⁺⁺ and (Na,K)⁺ + Al⁺⁺⁺ for Si⁺⁺⁺⁺ substitutions. (R⁺⁺ and R⁺⁺⁺ represent, respectively, divalent and trivalent cations in six-fold co-ordination, i.e. occupying positions at "Y" in Fig. 1 on page 2).

These sub-groups are:-

1. The Riebeckite - Glaucophane group: $\text{Na}_2\text{R}_3^{\text{++}}\text{R}_2^{\text{+++}}\text{Si}_8\text{O}_{22}(\text{OH})_2$
2. The Arfvedsonite group: $\text{Na}_2\text{Ca}_{0.5}\text{R}_{3.5}^{\text{++}}\text{R}_{1.5}^{\text{+++}}\text{Si}_{7.5}\text{Al}_{0.5}\text{O}_{22}(\text{OH})_2$
3. The Katophorite group: $\text{Na}_2\text{Ca}_1\text{R}_4^{\text{++}}\text{R}_1^{\text{+++}}\text{Si}_7\text{Al}_1\text{O}_{22}(\text{OH})_2$
4. The Soda-tremolite group: $\text{Na}_2\text{Ca}_1\text{R}_5^{\text{++}}\text{Si}_8\text{O}_{22}(\text{OH})_2$

The first three groups are in serial relation, being governed by the substitution of Ca⁺⁺ + R⁺⁺ + Al⁺⁺⁺ for R⁺⁺⁺ + Si⁺⁺⁺⁺. Each sub-group can be further sub-divided on the basis of Mg⁺⁺ for Fe⁺⁺ substitution in R⁺⁺, and Al⁺⁺⁺ for Fe⁺⁺⁺ substitution in R⁺⁺⁺. In the Riebeckite-Glaucophane sub-group, these sub-divisions, with their idealised, end-member formulae, are as follows:-

Riebeckite	$\text{Na}_2\text{Fe}_3^{\text{++}}\text{Fe}_2^{\text{+++}}\text{Si}_8\text{O}_{22}(\text{OH})_2$
Magnesioriebeckite	$\text{Na}_2\text{Mg}_3\text{Fe}_2^{\text{+++}}\text{Si}_8\text{O}_{22}(\text{OH})_2$
Glaucophane	$\text{Na}_2\text{Mg}_3\text{Al}_2\text{Si}_8\text{O}_{22}(\text{OH})_2$
Ferro-glaucophane	$\text{Na}_2\text{Fe}_3^{\text{++}}\text{Al}_2\text{Si}_8\text{O}_{22}(\text{OH})_2$

There appears to be complete miscibility between the end members in this sub-group. It has been found that high temperatures often favour the formation of minerals containing aluminium in four-fold co-ordination, i.e. substituting for silicon, whereas aluminium in six-fold co-ordination is formed at high pressures. (Mason, 1958, pp.75,245). The lack of aluminium substituting for silicon in the Riebeckite - Glaucophane sub-group suggests that the members were all formed at relatively low temperatures. The Glaucophane members, with large amounts of aluminium in six-fold co-ordination, can be regarded as the high pressure analogues of the Riebeckites (Miyashiro and Banno, 1958).

Four samples of fibrous riebeckite were analysed by the writer using a combination of gravimetric, colourimetric and spectrographic methods as detailed in Appendix No.1. In Table No.1 these analyses are compared with published analyses of fibrous riebeckite from various localities.

The samples from localities 1, 8 and 9 in Table No.1 were spectrographically analysed for trace elements with the following results:- (expressed in parts per million of the cations)

	Cr	Mn	Ba	Sr	Li	Rb	Cs
1.	320	240	n.d.	26	3.7	n.d.	n.d.
8.	330	n.d.	n.d.	70	17	n.d.	n.d.
9.	430	120	670	42	4.5	1.2	n.d.

Elements looked for, but not detected, were:-

B, V, Sc, Nd, Ce, La, Nb, Pb, W, Ce, Sn, Ga, Ag, Cu, Be,
Ni, Zr, Co, Au, Pt, Mo.

TABLE NO.1.

1. Crocidolite from Emmerentia Mine, Danielskuil, Specimen G34D.
2. Crocidolite from Kliphuis Mine, Prieska, Peacock (1928).
3. Crocidolite from Hurley Mine, Kuruman, Hall (1930), p.36, XI.
4. Crocidolite from the Main Reef, Koegas Asbestos Mine, in the Weathered Zone, 100 feet below surface. Cilliers and Genis (1961), Table No.1, 1.
5. Crocidolite from the Main Reef, Koegas Asbestos Mine, from the Fresh Zone, Cilliers and Genis (1961), Table No.1, 4.
6. Crocidolite from Pietersburg Asbestos, east of Malips Drift, Hall (1930), p.35, X.
7. Crocidolite from 8 miles SE of Willi Wolli Springs, Hamersley Range, W.Australia, Miles (1942).
8. Slip-fibre from Heuningvlei, Vryburg, Specimen G22M.
9. Mass-fibre from Dikberg Mine, Prieska, Specimen G97P.
10. Mass-fibre from Kliphuis Mine, Prieska, Peacock (1928).
11. Mass-fibre from Yampire Gorge, Hamersley Range, W.Australia, Miles (1942).
12. Fine magnesioriebeckite from Philadelphia Mine, Cristalmayn, Bolivia, Ahlfeld (1943).
13. Magnesioriebeckite from Lusaka, N.Rhodesia, Drysdall (1960), p.55.
14. Magnesioriebeckite from Etaneno, South West Africa, Specimen ET26.
15. Riebeckite ex Granite from Madagascar, Geol. Soc. Mem.32, p.753, No.5323.

TABLE NO. 1.

Locality	1	2	3	4	5	6	7	8	9	10	11	12	13	14	15
SiO ₂	52.4	51.94	52.30	49.90	51.26	59.40	51.94	52.3	53.6	50.71	45.51	55.16	56.10	50.0	48.40
Al ₂ O ₃	0.12	0.20	-	-	-	-	0.24	0.11	0.10	Nil	0.78	3.10	4.51	2.2	3.60
Fe ₂ O ₃	18.96	18.64	17.50	19.57	17.47	14.40	18.93	27.4	19.53	20.45	26.05	14.02	13.67	15.0	14.70
FeO	17.46	19.39	17.30	18.25	20.20	15.10	15.25	13.94	15.00	17.41	15.07	7.93	1.77	9.21	18.39
MnO	0.04	-	-	0.12	0.06	-	0.01	0.02	0.02	-	Nil	0.09	0.02	0.09	0.18
MgO	2.20	1.37	4.25	1.60	1.15	3.40	3.94	1.07	2.42	2.28	2.49	11.78	10.40	10.2	0.43
CaO	1.37	0.19	0.80	1.60	0.92	0.55	0.40	0.24	0.31	0.15	0.11	0.98	0.48	1.7	2.00
Na ₂ O	4.93	6.07	4.55	6.28	6.22	4.05	6.00	2.06	5.88	5.75	5.43	5.92	4.95	7.77	7.56
K ₂ O	0.13	0.04	-	0.18	0.17	-	0.26	0.02	0.06	0.07	0.05	0.60	0.23	0.86	1.96
H ₂ O ⁺	2.53	2.58	3.00	2.75	2.31	3.25	2.67	3.28	2.14	2.50	3.50	1.07	5.18	1.97	0.76
H ₂ O ⁻	*	0.31	0.80	0.23	0.29	0.10	0.72	*	*	0.96	1.24	-	2.74	*	0.05
TiO ₂	0.08	-	-	-	-	-	0.01	0.04	0.08	-	Nil	-	0.29	0.10	0.78
CO ₂	Nil	-	-	1.00	0.22	-	Nil	0.23	1.04	-	0.03	-	0.08	1.94	1.35 F
P ₂ O ₅	0.04	-	-	-	-	-	Nil	Nil	0.12	-	Nil	-	0.07	-	-
Cr ₂ O ₃	0.04	-	-	-	-	-	Nil	0.06	0.05	-	Nil	-	-	-	-
TOTAL	100.3	100.73	100.50	100.98	100.27	100.25	100.37	100.8	100.3	100.28	100.26	100.65	100.49	101.0	100.16
Analyst	J.H. Genis	H.E. Vassar	Govt. Chem. Lab. JHB.	Cape Asb. Lab. London.	Cape Asb. Lab. London.	Govt. Chem. Lab. JHB.	J.N. Grace.	J.H. Genis	J.H. Genis	H.E. Vassar	J.N. Grace	W. Brendler	E.W. Fowler	J.H. Genis	Raoult

- Oxide not determined.

* Analysis carried out on material dried at 110°C.

Analyses in heavy ruled columns were carried out by the writer.

The significant amounts of chromium probably substitute for ferric iron in R^{+++} . Manganese may substitute for ferrous iron or magnesium in R^{++} but on structural considerations it is more likely to occupy the "X" position in the amphibole lattice (Whittaker, 1949, p.316). The alkalis (Li,Rb,Cs) and the alkaline earths (Ba and Sr) also occupy this position. Substitution of ferrous iron or magnesium for ferric iron in the "Y" positions probably govern the acceptance of divalent ions in the "X" positions, thereby maintaining electrical neutrality.

The analyses in Table No.1 show significant variations in the major oxides, especially in the amounts of SiO_2 , MgO , FeO , Fe_2O_3 , Na_2O and H_2O . The isomorphous substitution of magnesium for ferrous iron may account for the variable content of MgO while variations in the Fe^{++}/Fe^{+++} ratio and H_2O content may be due to weathering effects. The majority of the variations are probably due to the presence of fine-grained impurities, especially quartz and magnetite, which are very prevalent in crocidolite. Both Miles (1942, p.28) and Vermaas (1952, p.25) suggested that ferrous and ferric iron together may substitute for sodium and silicon in some crocidolite, but it is doubted whether this substitution could take place at the low temperature of formation of most crocidolite. The ionic radius of the ferric ion, 0.64 Å, is too large for four-fold co-ordination, only six-fold co-ordination being favoured (Mason, 1958, p.74-75). It is more likely that the excess ferrous and ferric iron over the ideal formula requirements represents magnetite impurities in the analysed material. Excess ferric iron accompanied by a deficiency of ferrous iron in an analysis generally means oxidation of the ferrous iron during preparation of the sample. Crocidolite, owing to its finely fibrous nature, is extremely difficult to reduce to a powder and large amounts of ferrous iron may become oxidised during excessive grinding.

The analyses 1 to 8 and 12 to 15 were recalculated to total 100% after subtraction of H_2O^+ , H_2O^- , CO_2 and P_2O_5 together with sufficient FeO, MgO and CaO to form siderite, calcite or dolomite and apatite. The recalculated anhydrous weight percentages were converted to cation proportions. The cation contents of a half unit cell containing 23 oxygens were then calculated from these proportions. The original weight percentage of H_2O^+ was adjusted to fit the recalculated anhydrous analysis and then converted to a molecular proportion from which the number of H_2O molecules per half unit cell were determined.

The complete calculation for analysis 1 in Table No.1 is given as an example.

Oxide	Orig. anal.	Corr. anhyd.	Recalc. anal.	Cation factor	Cation prop. X 100.	Anion prop. X 100	Cations per 23 Oxygens	+ve charge
SiO ₂	52.4	52.40	53.66	1.664	89.29	178.58	7.99	31.96
Al ₂ O ₃	0.12	0.12	0.12	1.961	0.23	0.34	0.02	0.06
Fe ₂ O ₃	18.96	18.96	19.41	1.252	24.30	36.45	2.18	6.54
FeO	17.46	17.46	17.87	1.392	24.87	24.87	2.23	4.46
MnO	0.04	0.04	0.04	1.410	0.06	0.06	<.01	0.01
MgO	2.20	2.20	2.25	2.480	5.58	5.58	0.50	1.00
CaO	1.37	1.32	1.35	1.783	2.41	2.41	0.21	0.42
Na ₂ O	4.93	4.93	5.05	3.227	16.30	8.15	1.46	1.46
K ₂ O	0.13	0.13	0.13	2.123	0.27	0.13	0.02	0.02
TiO ₂	0.08	0.08	0.08	1.251	0.10	0.20	0.01	0.04
CO ₂	-	-	-	-	-	-	-	-
P ₂ O ₅	0.04	-	-	-	-	-	-	-
Cr ₂ O ₃	0.04	0.04	0.04	1.316	0.05	0.07	<.01	0.01
H ₂ O ⁺	2.53	-	(2.52)	5.551	13.99	-	1.25	-
TOTALS	100.3	97.68	100.00	-	-	256.84	-	45.98

$$\begin{aligned} \% \text{ CaO to form apatite with } P_2O_5 &= 1.1852 \times \% P_2O_5 \\ &= 0.05 \% \end{aligned}$$

$$\begin{aligned} \text{Apatite impurity} &= 0.05 + 0.04 \% \\ &= 0.09 \% \end{aligned}$$

The empirical formulae calculated from the analyses in Table No.1 are tabulated according to the theoretical formula of

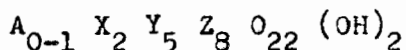

in Table No.2. Analyses 9 to 11 were not recalculated since the mass-fibre riebeckite contains variable amounts of chert, magnetite and other minerals as impurities and the analyses, therefore, do not represent the pure mineral.

All the analyses of crocidolite (1 - 7) show a remarkable fit to the theoretical formula. Analysis 6 shows too much silica. This may be due to the presence of free silica between the fibres in the original sample. Analysis 13 shows a similar excess of silica. Aluminium substitutes for silicon in trace amounts only, if at all, in contrast to the metasomatic and igneous riebeckites (12 - 15) where between 2½% and 6% of the silicon is replaced by aluminium.

Crocidolite contains between 10% and 25% water in excess of the theoretical requirements in contrast to the igneous and metasomatic riebeckites which contain the theoretical amount or less.

The ratio $Fe^{++} : Fe^{++} + Fe^{+++}$ is of the order of 0.55:1 in fresh samples of crocidolite. Ratios less than this indicate oxidation of the ferrous iron, either in the weathered zone or during preparation of the samples.

In crocidolite the replacement of ferrous iron by magnesium is negligible, the ratio $Fe^{++} : Fe^{++} + Mg$ approaching one. Crocidolite, i.e. asbestiform riebeckite associated with banded ironstones, is chemically near the Riebeckite end of the Riebeckite-Magnesioriebeckite series. In the metasomatic asbestiform riebeckite on the other hand, the ratio approaches 1 : 2, indicating a composition near the Magnesioriebeckite end.

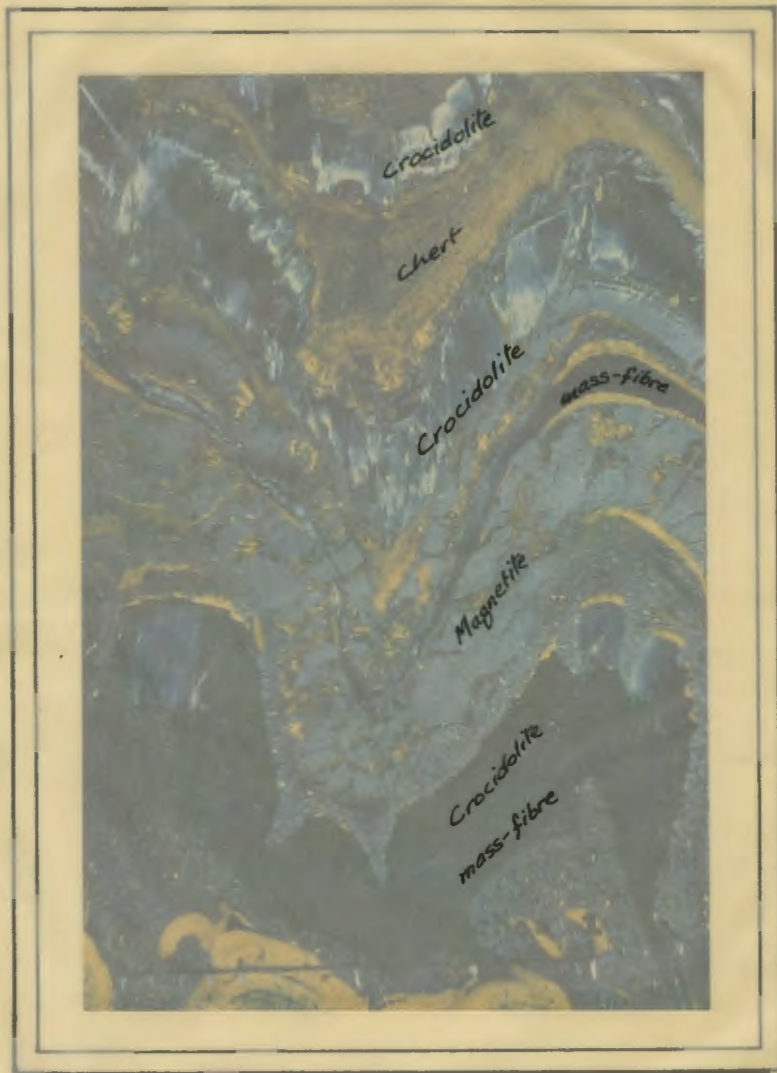

COMPETENT BEHAVIOUR OF CROCIDOLITE

Spec. G97P. No.3 level, Middle Reef, Dikberg
Mine, Prieska. $1\frac{1}{4}$ X natural size.

TABLE NO. 2.

Type of Riebeckite	Locality	Analysis number	CATIONS IN EIGHTFOLD CO-ORDINATION									CATIONS IN SIXFOLD CO-ORDINATION							CATIONS IN FOUR-FOLD CO-ORDINATION			ANIONS		Total positive Charge	Total negative Charge
			"A"			"X"						"Y"							"Z"			O ₂₂	(OH) ₂		
			H ₂ O	Na	O - 1	Na	K	Ca	Mg	Mn	Z	Fe ⁺⁺	Mg	Fe ⁺⁺⁺	Al	Cr	Ti	5	Si	Al	8				
Crocidolite	Danielskuil	1	0.25	-	0.25	1.46	0.02	0.21	-	0.01	1.70	2.23	0.50	2.18	0.01	.01	0.01	4.93	7.99	0.01	8.00	22.00	2.00	45.98	46.00
	Prieska	2	0.29	-	0.29	1.81	0.01	0.03	-	-	1.85	2.49	0.31	2.15	0.02	-	-	4.97	7.98	0.02	8.00	22.00	2.00	45.97	46.00
	Kuruman	3	0.48	-	0.48	1.35	-	0.13	0.19	-	1.67	2.21	0.78	2.01	-	-	-	5.00	8.00	-	8.00	22.00	2.00	45.99	46.00
	Westerberg	4	0.41	0.25	0.66	1.67	0.04	0.27	-	0.02	2.00	2.26	0.38	2.32	-	-	-	4.96	7.80	-	7.80	22.00	2.00	45.98	46.00
	Westerberg	5	0.17	0.07	0.24	1.81	0.03	0.15	-	0.01	2.00	2.60	0.27	2.04	-	-	-	4.91	7.98	-	7.98	22.00	2.00	46.00	46.00
	Malips Drift	6	0.53	-	0.53	1.15	-	0.09	-	-	1.24	1.85	0.74	1.58	-	-	-	4.17	8.69	-	8.69	22.00	2.00	46.01	46.00
	W. Australia	7	0.32	-	0.32	1.78	0.05	0.12	0.02	.01	1.97	1.95	0.88	2.17	-	-	.01	5.00	7.93	0.04	7.97	22.00	2.00	46.00	46.00
Slip-fibre	Vryburg	8	0.61	-	0.61	0.61	.01	0.04	0.14	.01	1.79	1.74	0.10	3.14	-	0.01	.01	5.00	7.96	0.02	7.98	22.00	2.00	46.02	46.00
Magnesio-Riebeckite	Bolivia	12	-	0.07	0.07	1.55	0.11	0.15	0.19	0.01	2.00	0.93	2.29	1.49	0.29	-	-	5.00	7.78	0.22	8.00	22.00	1.00	45.99	45.00
	N. Rhodesia	13	1.00	-	1.00	1.40	0.04	0.05	-	.01	1.49	0.21	2.25	1.49	0.77	-	0.03	4.75	8.15	-	8.15	22.00	2.00	45.96	46.00
	S.W. Africa	14	-	0.65	0.65	1.64	0.17	0.18	-	0.01	2.00	1.17	2.11	1.71	-	-	0.01	5.00	7.60	0.39	7.99	22.00	1.96	45.96	45.96
Rieb.	Madagascar	15	-	1.02	1.02	1.26	0.39	0.33	-	0.02	2.00	2.39	0.10	1.72	0.14	-	0.09	4.49	7.53	0.47	8.00	22.00	OH .78 F .65	45.97	45.43

Analysis number	1	2	3	4	5	6	7	8	12	13	14	15
$\frac{Fe^{++}}{Fe^{++} + Mg^{++}}$	0.82	0.89	0.69	0.86	0.91	0.71	0.68	0.88	0.27	0.08	0.36	0.96
$\frac{Fe^{++}}{Fe^{++} + Fe^{+++}}$	0.51	0.54	0.52	0.49	0.56	0.54	0.47	0.36	0.38	0.12	0.41	0.58
Impurities	A.09%	-	-	S2.16%	SO.47%	-	-	SO.50%	-	AO.15% CO.18% W .85%	D3.96%	-

A = Apatite
C = Calcite
D = Dolomite
S = Siderite
W = Water

Sodium is somewhat deficient in crocidolite. Minor amounts of calcium and traces of potassium substitute for sodium. In order to test for variations in the sodium content from various localities in the Cape and Transvaal Provinces of the Union of South Africa, a rapid quantitative spectrographic survey for sodium by a special technique described in Appendix No.1 was carried out. The results, together with published analyses for comparison, are given in Table No.3.

From Table No.3 it is evident that there is a slight, though noticeable, decrease in the sodium content of the crocidolite northwards from Prieska. This decrease is most marked in the Pietersburg District of the Transvaal. The crocidolite from the Hamersley Range in Western Australia appears to be similar to that from Prieska.

(b) Structure

Whittaker (1949) determined the structure of Bolivian magnesio-riebeckite. He found that it has the normal amphibole structure as exemplified by tremolite. It consists of ribbon-like double chains of linked silicon-oxygen tetrahedra parallel to the c-crystallographic axis. Sandwiched between the tetrahedral chains are octahedral ribbons of co-planar, metal ions in six-fold co-ordination. The t-o-t sandwiches are held together laterally by metal ions occupying the "X" positions in the diagram following. The importance of these structural positions has recently been shown by Whittaker (1960). The major differences in unit cell shape of the different amphibole varieties and the respective composition ranges of the ortho-rhombic and monoclinic amphiboles can all be related to the effects of the ionic radius of the cations occupying these positions. In the riebeckite structure the "X" positions are occupied by sodium ions.

The riebeckite structure is similar to talc (Pauling, 1930), but unlike talc, where the tetrahedral layers are kept flat by equal strain on opposite sides, the riebeckite tetrahedral chains curve away from the metal ion plane (octahedral layer) around an axis parallel to the c-crystallographic axis (i.e. an axis passing vertically through the O_7 atom in Fig.2, p.11). This curvature is the result of unequal strain on the tetrahedral layer due to the fact that it is attached to the metal ion ribbon on one side only and also because the metal ion ribbon has a slightly larger lateral extent (i.e. in the direction of the b-crystallographic axis). This curvature is similar to, although much less, than that occurring in the chrysotile structure (Aruja, 1945). The structure as determined by Whittaker (1949) is illustrated in Fig.2:-

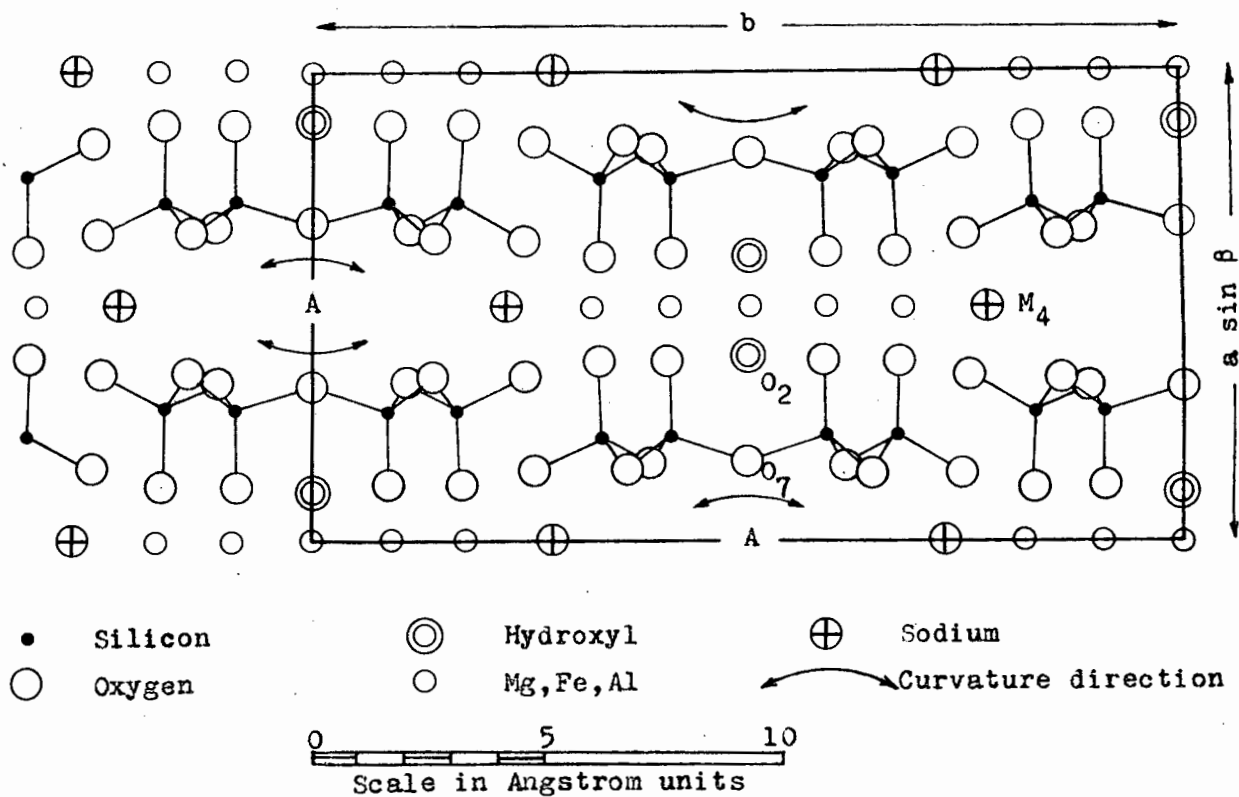

Fig.2. The structure of riebeckite (Whittaker, 1949).

The lateral binding force between the octahedral metal ion ribbons and the tetrahedral, silicate chains is much weaker than the Si - O bonds along the silicate chains. This is reflected in the fibrous or prismatic habit, parallel to the c-crystallographic axis, in riebeckite.

The structure contains essential water as $(OH)^-$ co-ordinated onto the octahedral layers at the O_2 position in the diagram above. The unit-cell contains four such $(OH)^-$ ions. When the unit-cell contents are calculated from analyses of crocidolite, water invariably exceeds the empirical formula requirements by between 10% and 25%. It is thought that this water occupies the "A" position in the lattice, which, according to Whittaker (1949), is vacant in riebeckite. The water probably becomes entrapped in this position during the formation

of the crocidolite, indicating that this took place at low temperatures. From Table No.2 it will be seen that the fibrous magnesioriebeckite contained in carbonatite (Analysis 14) and the riebeckite in granite (Analysis 15) has no water in the "A" position, indicating a higher temperature of formation.

The unit-cell dimensions of Bolivian magnesioriebeckite, as determined by Whittaker (1949), are, in Angstrom units:-

$$a = 9.89; \quad b = 17.95; \quad c = 5.31; \quad \beta = 72^{\circ}30'$$

Garrod and Rann (1952) found the unit-cell dimensions of Western Australian crocidolite to be:-

$$a = 9.6; \quad b = 18.3; \quad c = 5.3; \quad \beta = 70^{\circ}$$

The unit-cell of riebeckite contains two empirical formulae. The differences in unit-cell dimensions in these riebeckites can be related to the different proportions of Na, K, Ca, Mg, and Fe^{++} occupying the "X" positions.

Crocidolite can be heated to $400^{\circ} - 500^{\circ}$ C. without structural breakdown, but a certain portion of the ferrous iron becomes oxidised and the material loses its blue colour and much of its tensile strength. Between 890° and 1117° C. the co-ordinated water is expelled in an intense endothermic reaction. This is immediately followed by structural collapse and a strong exothermic reaction indicating the formation of a new mineral and possibly the oxidation of the remaining ferrous iron, (Vermaas, 1952, p.28). The structural collapse is accompanied by fusion. The products of the thermal decomposition of crocidolite are the monoclinic soda-pyroxene, acmite, haematite, cristobalite and water.

(c) Physical properties

Under the microscope fibrous riebeckite appears to have straight extinction. The individual, sub-microscopic, fibres are oriented parallel to the common fibre axis, the c-crystallographic axis, but have random orientations in all other directions. They occur clumped together in microscopic bundles. Under such conditions, bundles of monoclinic fibres will appear to have straight extinction. The bundle effect also makes the determination of refractive indices difficult. Indices of $\alpha = 1.693 \pm .002$ and $\frac{\gamma + \beta}{2} = 1.695 \pm .002$ were found for crocidolite from Dikberg Mine, Prieska, and $\alpha = 1.690 \pm .002$; $\frac{\gamma + \beta}{2} = 1.698 \pm .002$ for Transvaal crocidolite from the Pietersburg district. Miles (1942) reports an average $\beta = 1.695$ for crocidolite from Western Australia.

Fibrous riebeckite is strongly pleochroic with $X > Y, Z$
 $X =$ Deep Prussian Blue (parallel to the fibre axis) and
 $Y, Z =$ Indigo (perpendicular to the fibre axis).
 The fibres are usually length fast. No figure could be obtained owing to the bundle effect and the strong absorption of the fibres.

Specific gravity determinations on the fibrous riebeckite tend to be low because of the difficulty in eliminating air bubbles. Du Toit (1945) records specific gravities varying between 3.12 and 3.27, while Miles (1942) gives specific gravities of 3.31 and 3.27. An average of 20 determinations on pure fibre from Westerberg Mine, Prieska, gave a value of $3.42 \pm .01$, (Vermaas, 1952).

In certain cases, the fibrous riebeckite has recrystallised to form needle riebeckite. Relatively accurate refractive index determinations could be carried out on this material. The following optical constants are the averages of a number of determinations made in sodium light. The determinations all agree within .001 of the average.

Cape Province

(a) Needle riebeckite from Heuningvlei, Vryburg district.

$\alpha = 1.693$	Strongly pleochroic with
$\beta = 1.694$	X = Deep Prussian Blue
$\gamma = 1.697$	Y = Indigo
$\gamma - \alpha = .004$	Z = Buff yellow (Old gold)
α to $c = 3^{\circ}$	X > Y >> Z
$\beta = b$	

(b) Needle riebeckite from Dikberg Mine, Prieska district.

$\alpha = 1.690$	Strongly pleochroic with
$\beta = 1.694$	X = Deep Prussian Blue
$\gamma = 1.698$	Y = Indigo
$\gamma - \alpha = .008$	Z = Buff yellow (Old gold)
α to $c = 3^{\circ}$	X > Y >> Z
$\beta = b$	

Peacock (1928) found the following constants for needle riebeckite from Kliphuis Mine, Prieska district:

$\alpha = 1.698$	Strongly pleochroic with
$\beta = 1.699$	X = Indigo
$\gamma = 1.706$	Y = Yellow
$\gamma - \alpha = .008$	Z = Indigo
α to $c = 5^{\circ}$	(X and Y possibly interchanged)
Z = b	

Transvaal

Needle riebeckite from Beatrice Claims, Transvaal Asbestos, Pietersburg District:-

$\alpha = 1.690$	Strongly pleochroic with
$\beta = 1.692$	X = Deep Prussian Blue
$\gamma = 1.698$	Y = Indigo
$\gamma - \alpha = .008$	Z = Buff yellow
α to $c = 3^{\circ}$	X > Y >> Z
$\beta = b$	

(d) Intergrowths of riebeckite with grunerite

In the Pietersburg district of the Transvaal, crocidolite occurs in close association with amosite, the cross-fibre form of grunerite. Where both the crocidolite and the amosite have been recrystallised to the "needle" forms, a number of specimens of intimate intergrowths between riebeckite and grunerite were found (Plate II). These are of interest since they provide proof of the suspected miscibility gap between the Anthophyllite - Cumingtonite and Alkali groups of amphiboles. Boyd (1959, p.380) surmised that proof of this suspected gap would be provided by the association of riebeckite with grunerite.

The intergrown crystals have their c and b crystallographic axes common. They show good prismatic cleavage, but generally have tufted (fibrous) ends indicating incomplete recrystallisation from the original fibrous form. The boundary between the intergrown amphiboles appears to be random and does not follow any definite crystallographic direction.

The following optical constants were determined on a specimen from Rabieskloof, Transvaal Asbestos Company, Pietersburg district:-

<u>Grunerite:</u>	$\frac{\alpha + \beta}{2}$	=	1.680
	γ	=	1.702
	γ to c	=	17°

<u>Riebeckite:</u>	α	=	1.696
	$\frac{\gamma + \beta}{2}$	=	1.703
	α to c	=	3°

Strongly pleochroic with

X = Prussian Blue

Y = Indigo

Z = Old gold

X > Y >> Z

PLATE II

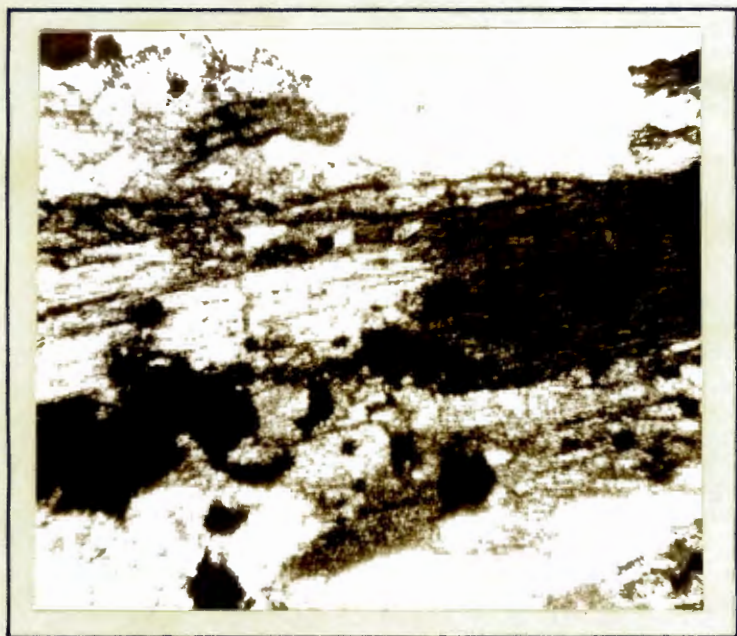

ASSOCIATION OF RIEBECKITE WITH GRUNERITE
Spec. G10T from Beatrice, Malips Drift, Tvl.
Plane polarised light, X 400 diameters.
Riebeckite (dark grey) on right hand side,
in crystallographic continuity with grune-
rite (light) on left hand side of plate.

III. THE MODE OF OCCURRENCE OF FIBROUS RIEBECKITE

Fibrous riebeckite occurs either as discrete tufts or sheaf-like bundles of minute fibres, as spherulitic masses with fibres radiating from a central nucleus (i.e. asteriated), or as veins (seams) with fibres arranged parallel and at high angles to the vein walls (i.e. cross-fibre).

(a) Tufts and spherulites of fibrous riebeckite

The typical appearance of tufts of fibrous riebeckite is illustrated in Plate IIIA. The tufts appear to be the result of dendritic growth from a discrete nucleus. Keller (1958), in a study of crystalline polymers, came to the conclusion that radiate spherulites develop from a single nucleus by fringing dendritic growth as illustrated below:-



Fig.3. The development of a fibrous spherulite by fringing dendritic growth from a central nucleus.

A similar process of fringing dendritic growth is believed to have resulted in the formation of radiate spherulites of riebeckite. All gradations from single tufts, to complete spherulites, are found in the riebeckite-bearing beds of the Transvaal System. These various stages are illustrated in Plate III. In certain beds the spherulites are so densely packed as to form a rock composed almost entirely of riebeckite (Plate IIIC). These beds are the so-called "mass-fibre", "potential" or "asteriated crocidolite" (Hall, 1930), or "amorphous riebeckite rock" (Forman, 1937), and "asteriated mass-fibre" (Miles, 1942).

PLATE III

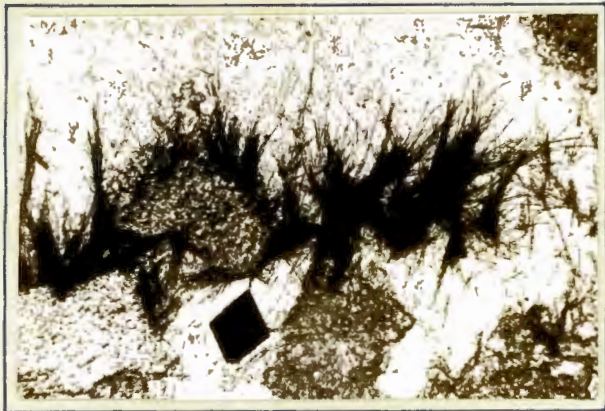

A. FIBROUS RIEBECKITE TUFTS

Spec.97P. Plane polarised light, X 400 diameters.

Fibrous riebeckite (black) growing preferentially on carbonate (high relief) rhombs set in chert (light).

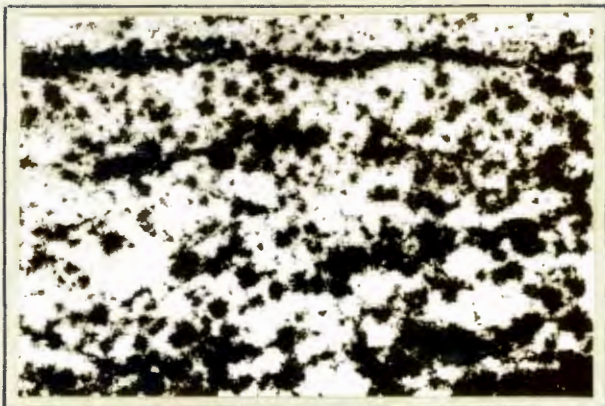

B. DISCRETE SPHERULITES OF FIBROUS RIEBECKITE

Spec.G26D. Ordinary light, X 10 diameters.

Fibrous riebeckite spherulites (black) set in chert matrix.

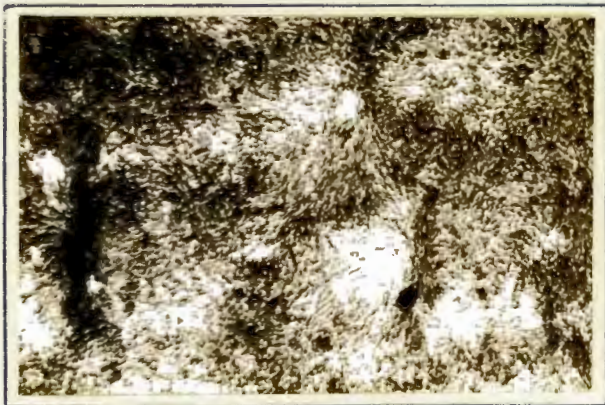

C. SPHERULITIC TEXTURE OF MASS-FIBRE RIEBECKITE

Spec.G76P. Plane polarised light, X 630 diameters.

Fibrous riebeckite grades in colour from light to dark grey due to pleochroism. Black specks are magnetite crystals.

For the purposes of this thesis these nearly pure riebeckite rocks will be referred to as "mass-fibre" or "mass-fibre riebeckite".

Dendritic growth appears to have been the favoured crystallisation process for riebeckite in the Transvaal System. The stage in development of radiate spherulites at which crystallisation stopped was probably dependent to a large extent on the availability of suitable material to form riebeckite. The mass-fibre bands represent beds originally composed almost entirely of riebeckite precursor material. In these beds the riebeckite most frequently occurs as complete radiate spherulites.

In dendritic crystallisation the distribution of nuclei and the flow of heat are important factors. Chalmers (1958, p.299) found that "in cellular growth the heat flow is everywhere from the liquid into the solid, (whereas) dendritic growth probably corresponds to a reversal of this situation at regions that are geometrically favoured". He (p.299) illustrates the heat flow and temperature gradient across the growing points during cellular growth and dendritic growth in the following way:-

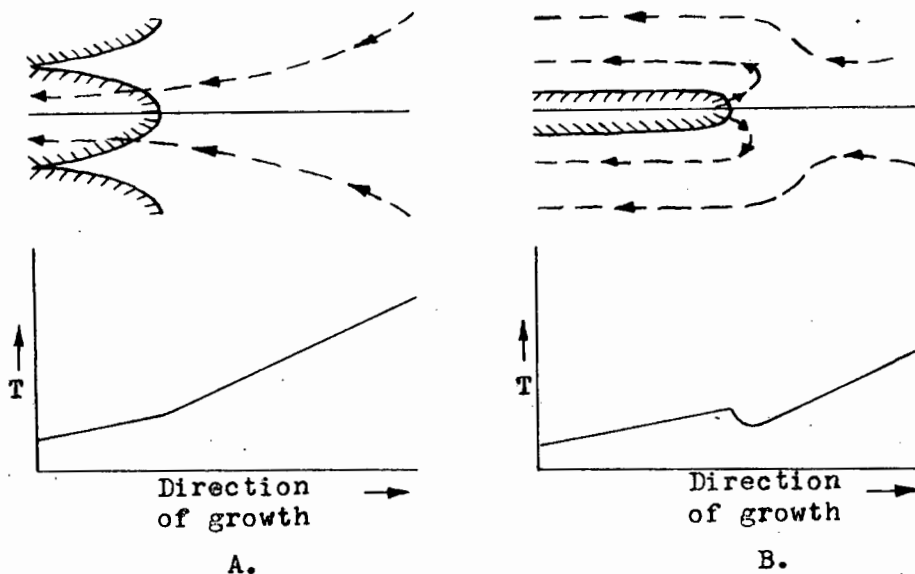

Fig.4. Flow of heat during A. cellular and B. dendritic growth.

TABLE NO. 3.

Country of Origin	District	Locality	Asbestos Zone	Spec. Number.	% Na ₂ O	Remarks
South Africa (Cape Province)	Frieska	Nauga Mine	Lower	G8P	5.27	Fresh
		Glen Allen Mine	Lower	G88P	4.92	Fresh
		Orange View	Lower	G48P	4.84	Weathered
		Kransfontein	Lower	G71P	5.10	Strongly deformed
		Kliphuis Mine	Lower	-	6.07	Peacock, 1928.
		Blaauwputs	Lower	-	4.40	Hall, 1930, XIV, p.36.
		Orange View	Intermediate	G56P	4.57	Deformed
		Koegasbrug	Westerberg	G45P	6.03	Fresh
		Westerberg Mine	Westerberg	-	6.22	Cilliers and Genis, 1961, No.4.
	Danielskuil	Emmerentia Mine	Lower	G34D	4.93	Upper Reefs, Fresh
		Klipvlei Mine	Lower	-	3.90	Hall, 1930, XIII, p.36.
	Kuruman	Newstead Mine	Lower (?)	G36D	5.25	Fresh
		Hartland Mine	Lower	G42D	5.76	Fresh
		Carrington Shaft	Lower	G48D	5.33	Fresh
		Hurley Mine	Lower	-	4.55	Hall, 1930, XI, p.36.
		Arcadia	Lower	-	4.40	Hall, 1930, XV, p.36
	Vryburg	Bute Mine	Lower (?)	G16M	4.33	Fresh
		Pomfret	Lower (?)	-	5.9	Cilliers and Genis, 1961, No.5.
South Africa (Transvaal)	Pietersburg	Rabieskloof	Middle or Upper	G19T	4.47	Weathered
		Rabieskloof	Middle or Upper	G22T	3.7	Weathered
		Beatrice	Middle	G23T	3.93	Fresh (?)
		Pietersburg Asbestos	-	-	4.05	Hall, 1930, X, p.35.
		Malips Drift	-	-	3.92	Hall, 1930, IX, p.35.
Western Australia	Hamersley Range	Wittencoom Gorge	-	G2M	5.42	Weathered
		Mount Margaret	-	-	6.12	Miles, 1942, No.1.
		Willi Willi Springs	-	-	6.00	Miles, 1942, No.2.

The fact that the flow of heat is reversed at the growing point of a dendrite growth assumes especial importance in the formation of crocidolite, as will be shown in Chapter VIII.

It is believed that the riebeckite in the Transvaal System was formed at an extremely low grade of thermal metamorphism. A slightly more advanced grade of metamorphism resulted in the recrystallisation of the originally formed, finely fibrous, riebeckite tufts or spherulites to form "needle" or "acicular" riebeckite. Miles (1942, p.36), is of the opinion that needle riebeckite results from the simple recrystallisation of fibrous tufts and that it does not represent an increase in metamorphic grade. Writers such as Peacock (1928), du Toit (1945) and Vermaas (1952), however, all agree that the presence of needle riebeckite indicates a higher grade of metamorphism than that required for the formation of fibrous riebeckite and crocidolite. This appears to be supported by the frequent occurrence of needle riebeckite within cross-fibre crocidolite seams near dykes and its greater prevalence in the Transvaal, where the Transvaal System suffered a more advanced grade of metamorphism than in the Cape. The needles of riebeckite usually have random orientations. Only in certain cases where they crystallised in a crocidolite seam, do they show a rough parallelism.

The typical occurrence of fibrous riebeckite is in the chert-carbonate rocks associated with the Banded Ironstone Zone of the Transvaal System. These occurrences will be further described in Chapter V. Similar fibrous riebeckites occur in the Nullagine Series of Western Australia. Other occurrences of fibrous riebeckite, not associated with banded ironstones, are:-

1. In altered arkoses associated with the Chuos Tillite of South West Africa. Bundles and tufts of fibrous riebeckite, elongate in all directions parallel to the bedding planes, were formed at

the expense of biotite during the feldspathisation of arkosic quartzites and biotite schists by intruding granite (Fockema, 1953).

2. In stockworks and veins of randomly to completely orientated tufts and fibres, usually inclined at low angles to the vein walls, in altered magnesian limestones. The individual fibre bundles may attain appreciable lengths in these occurrences. The riebeckite is formed as a result of soda-metasomatism and thermal metamorphism of the limestones by intruding granites and is of the magnesioriebeckite variety. Examples of such occurrences are found in Bolivia (Ahlfeld, 1943), Northern Rhodesia (Drysdall and Newton, 1960) and in Southern Australia (Jack, 1921; Wymond and Wilson, 1951).

3. In carbonatite at Etaneno, S.W.A., and Spitskop, Transvaal. At Etaneno, 0.5 mm. pods, containing sub-parallel fibres of riebeckite, occur interstitially in coarsely crystalline carbonate (Plate IVA). At Spitskop, tufts and bundles occur as interstitial patches or partly aligned veins in coarsely crystalline carbonate (Plate IVB). In both occurrences, the carbonate is of the magnesium-rich type. Analysis 14 shows that the riebeckite in the Etaneno carbonatite is a magnesioriebeckite. Its pod-like appearance may have resulted from either the crystallisation of globules of an immiscible silicate phase in a carbonate magma, or from the restricted crystallisation of the silicate phase in a highly viscous medium. Similar pod-like spherulites of copper sulphate were produced by the crystallisation of a supersaturated solution of copper sulphate in a solid setting gel of gelatine (Plate IVC). The latter mode of formation therefore appears to be the more likely. Danielson (1950) found that the partition of calcium between silicate and carbonate phases is in part dependent upon the partial pressure of carbon dioxide. High $p.\text{CO}_2$ favours the formation of CaCO_3 and Ca-poor silicates.

PLATE IV

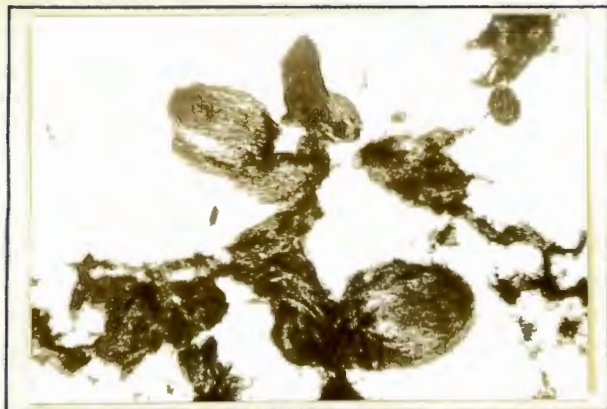

A. GLOBULES OF FIBROUS RIEBECKITE
IN CARBONATITE

Spec. ET26 from Etaneno, S.W.A.
Plane polarised light X 120
diameters.

Fibrous riebeckite (grey) in
carbonate (white).

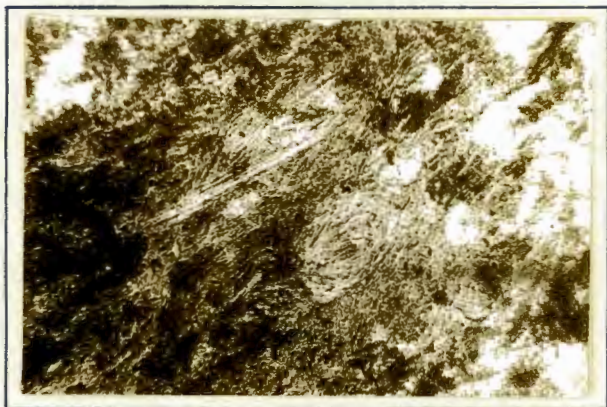

B. RIEBECKITE IN CARBONATITE

Spec. G4M from Spitskop, Tvl.
Plane polarised light, X 345
diameters.

Fibrous riebeckite (light to
dark grey) in carbonate (white).

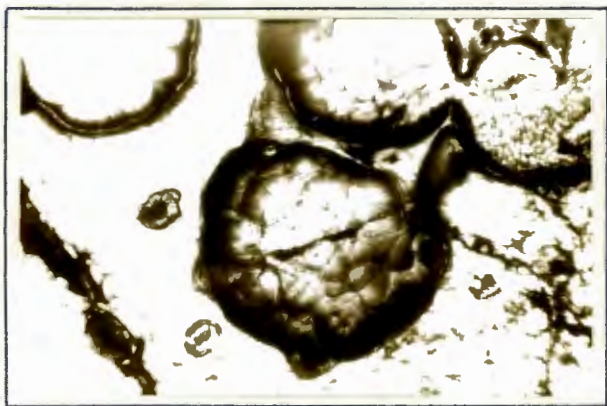

C. GLOBULAR SPHERULITES OF
COPPER SULPHATE

Ordinary light, X 78 diameters.

Fibrous copper sulphate globules
(light to dark grey) in gelatine.

The Etaneno carbonatite probably crystallised under conditions of high viscosity, high $p.CO_2$ and low temperature. A high temperature would have favoured the formation of soda-tremolite instead of riebeckite (Ernst, 1960, p.38).

4. In pipe-like pegmatite bodies associated with the Quincy granites of Rhode Island and Massachusetts. The fibrous riebeckite occurs as felted masses in the central cores of the pegmatite bodies. The granites, from which the pegmatites derive, contain tabular crystals of riebeckite and aegerine, (Warren and Palache, 1911; Emerson, 1917). Ernst (1959, p.123), shows that the amphibole in the granite is not pure riebeckite, but arfvedsonitic in composition, probably consisting of a solid solution of riebeckite and arfvedsonite. He relates this fact to the oxygen partial pressure during the crystallisation of the magma. The high FeO to H_2O ratio, causing a low $p.O_2$, together with the high temperature, favoured the formation of an amphibole near the arfvedsonite end-member in composition. During the aqueous, pegmatite phase, the lower temperature, together with the relatively higher $p.O_2$, caused by the strong decrease in the ratio of FeO to H_2O , resulted in the crystallisation of riebeckite.

The riebeckites in the above occurrences are all of the magnesium-rich type (refer analyses 12, 13 and 14 on p.5) and lie near the Magnesioriebeckite end of the Riebeckite-Magnesioriebeckite Series of the Alkali amphiboles. They all contain the theoretical amount of water or less, in contrast to crocidolite which invariably contains excess water.

(b) Veins or Seams of cross-fibre riebeckite

Fibrous riebeckite occurs as cross-fibre veins or seams in the Banded Ironstone Zone of the Transvaal System of South Africa, in the Nullagine Series of Western Australia and in Central China. The mode of occurrence and associations of the seams in the first two countries are very similar and only the South African occurrences will

be described. The reader is referred to a paper by Miles (1942) for a description of the Western Australian deposits. Unfortunately, no literature on the Chinese deposits is available to the writer.

Transgressive veins of cross-fibre riebeckite

Cross-fibre riebeckite veins, i.e. crocidolite seams, are unique in that they are invariably conformable to the bedding of their host rocks. Only in extremely rare cases have veins been found which cut across the strata at high angles. Low angle, transgressive veins have never been reported and were not seen in any of the exposures examined by the writer.

An occurrence of a high angle, transgressive vein of cross-fibre riebeckite in the Mansfield Mine, Kuruman district, is described by du Toit (1945, p.174). Similar veins have been found in the Westerberg Mine, Prieska district. In a specimen from this mine, No. G40P, Plate V, the fibre is of a much coarser and more brittle nature than that occurring in the normal bedded seams. The soda-content is also much less; 2.89% Na₂O as compared to 6.03% Na₂O in the normal bedded seams (crocidolite, specimen No.G45P). The fibre appears to have been emplaced in a dilation vein which postdates the lithification of the rocks. The riebeckite in the vein came from an overlying bed of mass-fibre and was emplaced together with quartz and calcite, which also show a rough, cross-fibre, alignment. The riebeckite appears to be in a crystalline state between fibrous and needle riebeckite. The fibre bundles are length-fast with $\alpha - c = 4^\circ$; $\alpha = 1.690 \pm .002$, and $\frac{\beta + \gamma}{2} = 1.694 \pm .002$. They are strongly pleochroic with X > Y, Z. X = deep prussian blue and Y, Z = indigo to greyish blue.

The emplacement of the transgressive veins took place with very little disturbance of the strata, as can be seen in Plate V

PLATE V



TRANSGRESSIVE VEIN OF CROSS-FIBRE
RIEBECKITE

Spec.G40P, Westerberg Mine, Prieska.
Natural size.

where a single 1 cm. thick bed of banded chert continues relatively undisturbed through the vein. Post-emplacement, lateral pressure resulted in the bending and slight shearing of the fibres along one of the vein walls. A very small component of differential pressure accompanied the lateral pressure resulting in a slight vertical displacement of the beds. The vein-filling shows a vague banding parallel to the vein walls in addition to the cross-fibre habit. This banding is probably due to interrupted growth during the formation of the vein.

Conformable seams of crocidolite

The conformable, cross-fibre riebeckite seams, i.e. crocidolite seams, occur along definite horizons or zones within the banded ironstones. These horizons are virtually confined to the so-called riebeckite-bearing beds in which the tuft and spherulitic types of fibrous riebeckite are more prevalent. Although fibrous riebeckite occurs in variable amounts throughout the Lower Griquatown Stage of the Pretoria Series, by far the greatest concentrations are present in the riebeckite-bearing beds. These beds are generally of the order of 100 to 200 feet thick and are continuous over long distances. Their thinly bedded nature and the fact that they tend to form ridges make them easily recognisable in the field. The outcrop of a riebeckite-bearing bed, containing a crocidolite horizon, is illustrated in Plate VI.

Crocidolite seams occur anywhere within the riebeckite-bearing beds, but are generally found concentrated in narrow "reefs", comprising some 3 to 10 feet thickness of strata. The term "reef", as used in connection with the occurrence of crocidolite, can be defined as a concentration of crocidolite seams capable of being mined as a unit.

PLATE VI



OUTCROP OF RIEBECKITE-BEARING BED,
PRIESKA DISTRICT

Crocidolite horizon outcrops along middle of bed. Note small working on right hand side of Plate. Dyke, showing typical declivity developed by weathering, cuts through strata on left hand side of Plate.

A number, generally from 4 to 6, of "reefs" occur within a single crocidolite horizon. The reefs contain from three to five, 2 to 10 mm. thick crocidolite seams. In favourable areas they may contain as many as fifteen seams varying from less than 1 mm. to more than 50 mm. in thickness. The reefs are generally over- and underlain by relatively barren strata, which may, however, contain one or two impersistent crocidolite seams of minor thickness.

In certain cases, the normally barren, inter-reef strata contain appreciable concentrations of crocidolite, as shown in Fig.5.

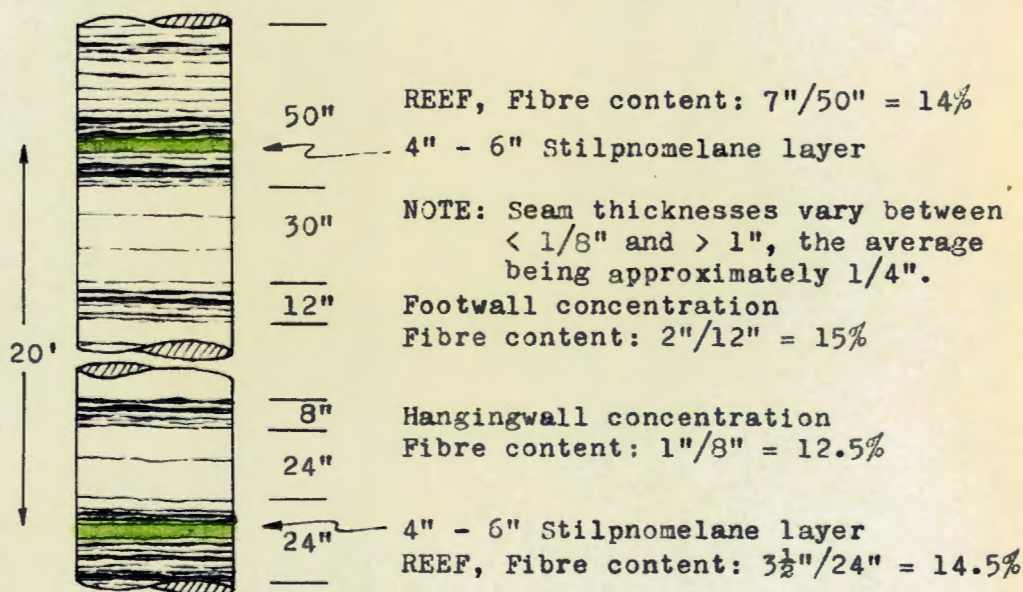

Fig.5. Inter-reef concentration of crocidolite at Warrendale Mine, near Danielskuil.

The inter-reef concentrations may assume such proportions that no division between reef and intervening strata can be made. Such is the case at Kuruman, where in favourable areas, the "reef" may attain total thicknesses of up to 30 feet and contain as much as 20% by volume of crocidolite.

From two to five crocidolite horizons, each contained in a separate riebeckite-bearing bed, have been identified in the Cape Province. In the Prieska area, five such horizons are distributed in some 3,000 feet thickness of banded ironstone. Further north, in the Danielskuil area, three horizons are present in some 1000 feet thickness of strata. At Heuningvlei, near the northern extent of the banded ironstone in the Cape Province, only two crocidolite horizons are thought to be present in less than 1000 feet thickness of strata.

In the Pietersburg area of the Transvaal, four asbestos-bearing horizons can be recognised in some 800 feet thickness of banded ironstone. They are generally thinner than in the Cape. They contain much grunerite both as needles and as cross-fibre seams, i.e. amosite. This is in strong contrast to the Cape riebeckite-bearing beds where no grunerite is found. The uppermost horizon in the Transvaal contains predominantly grunerite and can hardly be classed as a crocidolite horizon.

The height above the dolomite contact at which the various crocidolite horizons occur can be used as a basis of correlation. Table No.4 lists the Horizons found in the Cape Province and in the Pietersburg area of the Transvaal.

The Actinolite Horizon of the Prieska area contains a number of cross-fibre actinolite asbestos seams. Not much is known about this zone. It was only seen in one exposure on the farm Orange View, near Prieska, where a few 1/8" to 1/4" thick seams of semi-slipfibre to slipfibre occur over some 3 feet of strata. It apparently occurs at a definite horizon between the Intermediate and Westerberg Horizons in the Prieska district according to Mr. J. Cilliers of Koegasbrug, who

N 82
H 2

TABLE NO. 4.

Area	Asbestos Horizon	Estimated Height above Dolomite (in feet)	Thickness of Horizon (in feet)	Number of Reefs	Type of Asbestos	Remarks
Prieska	Upper	3,000	5 - 10	1 - 2	Crocidolite	Sporadic
	Westerberg	2,400	80 - 100	4 - 10	Crocidolite	Very extensive
	Actinolite	2,000	?	?	Actinolite	Sporadic
	Intermediate	1,500	150 - 200	3 - 4	Crocidolite	Extensive
	Contorted	800	50 - 100	?	Crocidolite	Very sporadic, contorted.
	Lower	50 - 100	100 - 200	5 - 10	Crocidolite	Very extensive
Danielskuil	Long Fibre	550	80 - 100	2 - 3	Crocidolite	Sporadic
	Upper	350	80 - 100	2 - 3	Crocidolite	Sporadic
	Lower	200	80 - 100	4 - 6	Crocidolite	Extensive
Heuningvlei	Upper	300 (?)	100 - 120	3 - 4	Crocidolite	Extensive
	Lower	100 (?)	5 - 10	1	Crocidolite	Sporadic
Pietersburg	Upper	700	20 - 30	2 - 3	Amosite	Extensive
	Short fibre	400	20 - 30	2 - 3	Crocidolite	Sporadic
	Main	180	60 - 100	4 - 5	Crocidolite and amosite	Crocidolite predominates over amosite in the west and vice versa in the east
	Lower	80	50 - 60	4	Crocidolite and amosite	

also suggested the name "Prieskite" for the actinolite asbestos (personal communication). The fibre from Orange View (specimen G51P) is pale-greenish to ash-grey in colour. Under the microscope it can be seen to be finely fibrous, although relatively coarser than crocidolite. Fibre bundles have the appearance of twinned plagioclase laths due to the random orientation of the a- and b-crystallographic axes, the c-crystallographic axes of the fibres being near parallel. The fibres are length slow with γ to c = 6° to 7° and refractive indices of $\frac{\alpha + \beta}{2} = 1.665 \pm .002$ and $\gamma = 1.691 \pm .002$.

The Lower Horizon is the best-known and probably the most extensive of all the crocidolite horizons. It is present over the entire stretch of banded ironstone in the Cape Province from 25 miles south of Prieska to where it crosses the Bechuanaland border in the north. The sporadic occurrences of crocidolite in the Thaba Zimbi area of the Transvaal (du Preez, 1944), probably belong to this horizon, as well as the extensive mixed amosite/crocidolite Lower Horizon of the Pietersburg district. In this district, near Malips Drift, the horizon undergoes a gradual change, becoming increasingly rich in grunerite (amosite) as one proceeds eastwards. The amount of crocidolite decreases until the horizon is entirely amosite-bearing at Penge in the Eastern Transvaal.

The reefs in the lowermost crocidolite horizons of the Cape Province are invariably accompanied by one or two beds composed almost entirely of stilpnomelane. The stilpnomelane beds vary in thickness from a few inches to 4 or 5 feet. They occur in close proximity to the reefs, either above, below or within the reef itself. Being virtually unbedded and blackish-green in colour, they stand out in sharp contrast to the finely laminated reef strata as shown in Plate VII. In the weathered zone, these stilpnomelane beds are oxidised and hydrated to a soft brown mud. In the earlier days of mining for asbestos in

PLATE VII



STILPNOMELANE LAYER (BOORNAAT)
IN CROCIDOLITE REEF

Stope on No.3 level, Middle Reef, Dikberg Mine, Prieska.

Stilpnomelane layer (black), crocidolite (blue) and banded ironstone (yellow). The predominant yellow colour of the banded ironstone denotes that this level, 250 feet below surface, is still in the Weathered Zone.

the Cape fields, all drilling was done by hand and these mud seams were favoured as drill sites, hence the name "Boornaat", i.e. drilling seam, by which the beds are known. The significance of the stilp-nomelane beds is further discussed in Chapter VI.

The sporadic occurrence of crocidolite

The impersistence of economically important concentrations of crocidolite is well known. The number and thickness of crocidolite seams in a reef may decrease rapidly and die out completely over a relatively short distance. The continuation of the barren reef may still contain mass-fibre riebeckite, although even this may disappear rapidly. A deposit is usually considered to constitute an ore-body when it contains one or more reefs with crocidolite in excess of 3% by volume over the normal stoping width of 4 to 5 feet.

The crocidolite ore-bodies may be roughly circular in outline but are generally elongate along strike and are of the order of 50 to 100 feet wide and a few hundred feet long. An exception was seen in Dikberg Mine, Prieska, where the ore-body continues down dip for some 350 feet and is only 200 feet wide. At Middelwater in the Prieska district a single reef in the Lower Horizon was found to contain one persistent crocidolite seam over an exposure length of 22,000 feet. This seam varies between $\frac{1}{4}$ " and 1" in thickness. It is frequently accompanied by 2 or 3, $\frac{1}{4}$ " to $\frac{1}{2}$ " thick seams, but these are impersistent and die out within a few tens of feet. Where the accompanying seams die out, the persistent seam was generally found to be of lesser thickness.

The seams within a reef appear to bear an antipathetic relationship to each other. Long fibres in one seam are generally accompanied by short fibres in the overlying or underlying seams, and vice versa.

In numerous occurrences, especially in the Lower Horizon of the Kuruman area, rich developments of fibre tend to be superimposed. The ore-bodies are roughly elliptical in outline and contain a number of thick, superimposed reefs which carry numerous crocidolite seams.

From the small number of observations available to the writer, it appears that the Prieska district was a favourable area for the development of crocidolite. The crocidolite reefs in the Lower Crocidolite Horizon, although not always of mineable grade, appear to be more extensively developed than in the rest of the Cape fields. The very extensive Westerberg Horizon with its large economic concentrations of crocidolite occurs in this area.

Relation of crocidolite to folding

The frequent association of crocidolite enrichments in the reefs with sharp monoclinial flexures, the so-called "rolls", especially in the Lower Horizon, has led a number of authors, notably du Toit (1945), to postulate a tectonic control for the formation of crocidolite. Equally numerous, however, are "rolls" which show no crocidolite enrichment, as well as enriched reefs which show no evidence of folding.

It is thought that the actual formation of crocidolite is completely unrelated to dynamic stresses. The frontispiece Plate shows very clearly that the crocidolite was already formed when the folding took place. It was brecciated by the folding, while the remaining strata behaved plastically. Plate VIIIA illustrates a crocidolite seam continuing with roughly equal thickness around the flanks, crest and trough of a fold, the fibre orientation being everywhere normal to the bedding. Of particular interest is the occurrence of mass-fibre riebeckite below this seam. The mass-fibre represents

PLATE VIII

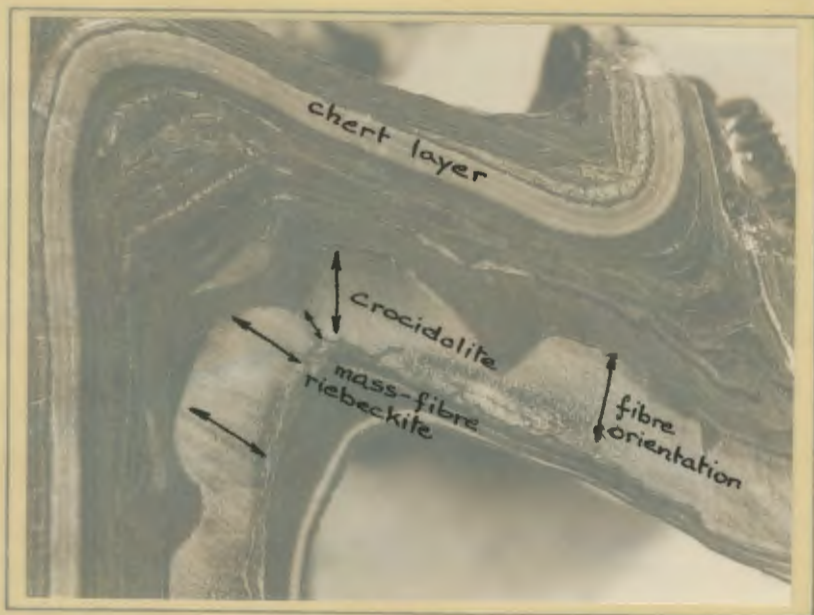

A. SMALL ISOCLINAL FOLD
Spec.G43D. Natural size.

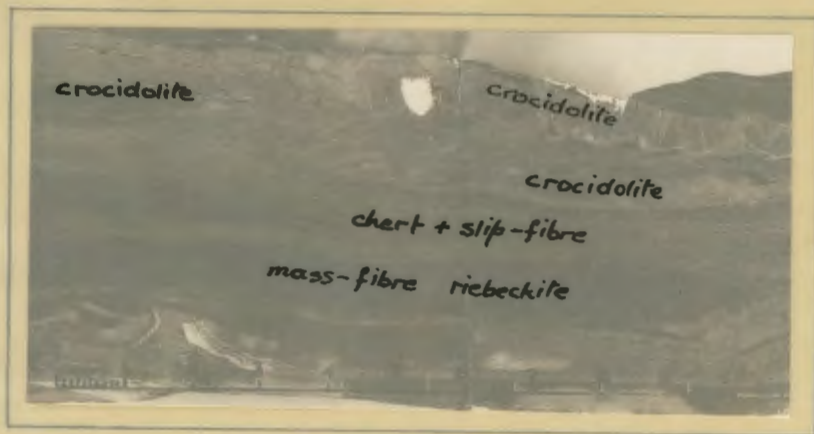

B. SMALL SCALE NAPPE STRUCTURE

Spec.G71P. 9/10ths natural size.

Dark grey overthrust band near bottom
of Plate is mass-fibre riebeckite.

material which was suitable for the formation of crocidolite. Although it was thickened by plastic flow from the flanks into the low pressure areas along the crest and trough of the fold, no crocidolite developed in the layer. The significance of this fact will be further discussed in Chapter VIII.

The association of some enriched reefs with "rolls" are believed to be due to a period of gentle folding which affected the banded ironstone prior to the formation of crocidolite. The sediments were still in a plastic state and folding resulted in the thickening of the more plastic layers, especially the highly plastic, clay-like "riebeckite-precursor", along the crests and troughs of the folds. More intense deformation caused the development of pod-like concentrations in the crests of folds which, when transformed to crocidolite, resulted in the typical "saddle" reefs found in some "rolls". A small scale "saddle" development can be seen above the main seam in Plate VIIIA. More intense folding caused the development of numerous, minute overfolds, each with a pod-like concentration of riebeckite precursor in the crest. The pod-like crocidolite concentrations found in the highly contorted reefs of the Contorted Horizon at Prieska are thought to have originated in this way. The intense, post-crocidolite folding further accentuated the pod-like segregations by strong overfolding and shearing. In specimen G71P from the Lower Horizon at Orange View in the Prieska district a crocidolite seam and a mass-fibre riebeckite band were thrust over a contorted layer during this later period of deformation. Movement took place along the lower contact of the crocidolite seam with the contemporaneous development of slip-fibres along the shear surface (Plate VIIIB).

Morphological features of the crocidolite seams:

The individual fibres within the crocidolite seams are made up of bundles of minute, elongate crystallites of riebeckite, arranged

with their c-crystallographic axes nearly parallel, but with their a- and b-axes randomly orientated. The fibres, which are arranged parallel, are continuous from wall to wall, typically meeting the walls at high angles, to form the so-called "cross-fibre" seams. They vary in length from microscopic dimensions to 10 cm. in exceptional cases. Usual fibre lengths are between 1 mm. and 25 mm.

The outstanding feature of the cross-fibre seams is the rapid variation in fibre lengths over very short distances. Fibres increase in length from less than 1 mm. to more than 25 mm. within a distance of 20 mm. or less. Seams seldom retain a uniform thickness due to the rapid variations in fibre length, variations which are typically reflected along one contact only. As a result one surface of the seam always has a highly convoluted or cone-like appearance as illustrated in Plate IXA, while the opposite surface is planar.

In section the convoluted contact presents a wavy outline, the other contact being relatively straight and invariably parallel to the bedding. In only one specimen, No. G22D, did the planar contact of a crocidolite seam appear to cut across the crest of a small fold, the bedding planes meeting the contact at an angle (Plate IXB). Closer examination of the specimen showed that the planar contact was located on a minor shear plane which cut across the bedding.

Seams with both contacts straight and parallel to the bedding are frequently found. In such seams one or more thin layers of magnetite crystals, the so-called magnetite screens, invariably occur within the seam. These layers reflect the wavy outline normally shown by the convoluted surface (Plate X). Seams with one wavy contact also frequently contain such magnetite layers, which often show a sub-parallelism to the wavy contact. Any one cone in the seam may thus contain a number of subsidiary cone-shaped layers of

PLATE IX



A. CONVOLUTED SURFACE OF CROCIDOLITE SEAM

Spec.G23D. $\frac{1}{2}$ natural size (Scale below specimen in eighths of inches).

Lower portion of Plate shows seam in section with crocidolite (light grey), magnetite screens (black) and banded ironstone (dark grey).



B. FOLD CUT OFF BY CROCIDOLITE SEAM

Spec.G22D. 1.2 X natural size.

Folded strata below crocidolite seam consists of carbonate and chert (white) and fibrous riebeckite (dark grey).

PLATE X

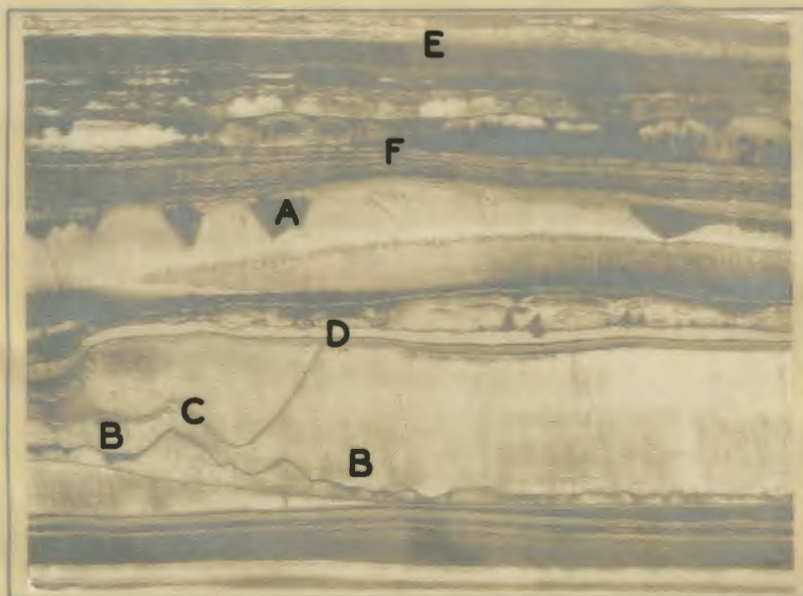

SECTION OF CROCIDOLITE SEAMS SHOWING VARIOUS MORPHOLOGICAL FEATURES

Spec.G40D. Natural size.

Features shown are:-

- A. Convoluted surface of crocidolite seam showing magnetite screen and mass-fibre riebeckite on opposite side of screen as well as along lower contact of the seam.
- B. Medial magnetite partings in seam with two planar contacts. Mass-fibre riebeckite usually associated with such partings shows up black on Plate in contrast to dark grey colour of the magnetite.
- C. Cone-in-cone structure.
- D. Bifurcation of magnetite screen.
- E. Unconverted mass-fibre riebeckite layer with magnetite screen (along upper contact).
- F. Plastic flow of material ahead of growing seam.

magnetite, resulting in a cone-in-cone structure. Such structures, where the layers are thicker than normal, being composed of a magnetite screen together with a thin layer of material unsuitable for the formation of crocidolite, are also found.

The magnetite screens:

In the Cape Province, the crocidolite seams are invariably accompanied by thin "screens" of microcrystalline magnetite. The screens occur as cappings to the fibres along the wavy contacts of the seams, the planar contacts usually containing only a few scattered magnetite crystals. Sometimes both contacts of a seam are capped by wavy magnetite screens. In such cases, the seam has a very thin, straight, central parting of chert and/or mass-fibre, and can be regarded as two seams which grew in opposite directions. In seams with both contacts parallel to the bedding, the contacts contain only scattered magnetite crystals. The magnetite screen forms the medial parting common in such seams.

In certain crocidolite seams, the magnetite screen appears to alternate between two relatively straight contacts, passing through the seam at low angles. The screen presents a sinusoidal appearance as it oscillates from contact to contact. Closer examination of such cases usually reveals a bifurcation of the screen. One arm of the bifurcated screen passes through the seam at a low angle and may even cap the opposite contact for a short distance. The other arm continues along the contact originally occupied by the screen (Plate X).

The magnetite screens are uniform in thickness over several centimetres and bear no direct relationship to the fibre length, as shown in Plate XIA. They do not represent the excess iron over that required for the formation of crocidolite from the material contained

PLATE XI

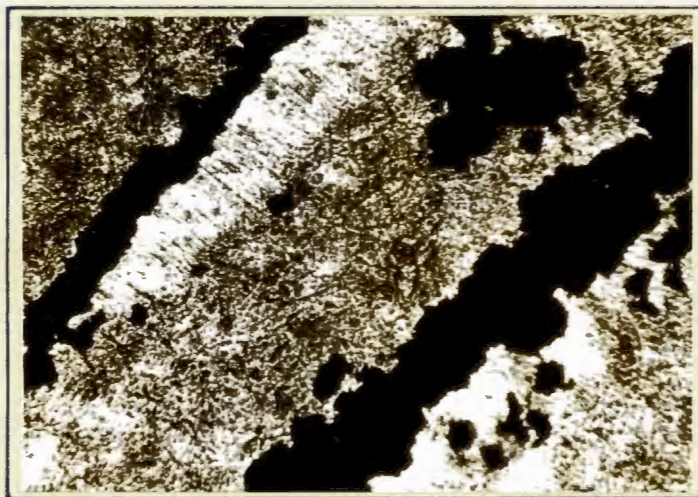

A. RELATIONSHIP OF FIBRE LENGTH TO
MAGNETITE SCREEN THICKNESS

Spec.G41D. Plane polarised light,
X 345 diameters.

Thick screen in lower right hand corner
carries much shorter fibres than thin
screen in upper right hand corner of
the Plate.

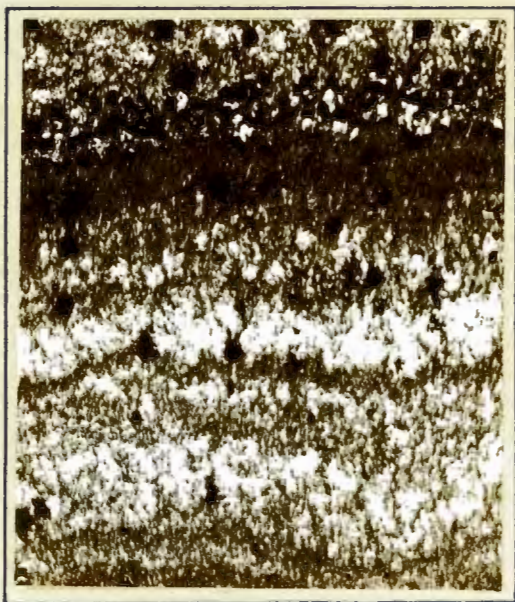

B. RECRYSTALLISED FIBRE
AND MAGNETITE SCREEN

Spec.G20T. Plane polarised
light, X 10 diameters.

Recrystallised crocidolite
(dark grey) capped by mag-
netite octahedra (black) in
upper portion of Plate.

No. 1000

in the rocks, as suggested by du Toit (1945, p.193). It is thought that the magnetite screens are the dehydrated and recrystallised equivalents of thin layers of magnetic iron hydroxide, which were formed during the deposition of the banded ironstones, and that they play a major role in the formation of cross-fibres (refer Chapter VIII).

The relationship of magnetite screens to crocidolite is not so obvious in the Transvaal. The intense deformation and higher grade of thermal metamorphism suffered by the Transvaal rocks after the formation of the crocidolite obscured the relationship to a certain extent by shearing and recrystallisation. Traces of the original screens, now much recrystallised, are found along the contacts of the seams (Plate XIB). The relatively large magnetite octahedra included in the seams probably derived from original wavy magnetite partings within the seams.

Impurities within the seams:

The most common impurity is magnetite. In the Cape fields it occurs as micro-crystalline patches and stringers within the crocidolite seams. It is thought that these magnetite impurities are remnants of magnetite screens which broke off and were left behind within the seam during fibre growth. In the Transvaal the magnetite impurities occur as large octahedra, probably the recrystallised equivalents of screen remnants left behind during fibre growth.

Another frequent impurity is quartz, which occurs as interstitial needle-like crystals. The quartz impurities may be due either to contemporaneous growth with crocidolite during the formation of the seam, or to the later replacement of bundles of crocidolite fibres (Thiesmeyer, 1937). Quartz crystals emplaced in the latter fashion usually contain thread-like inclusions of unreplaced crocidolite (Plate XIII A). Interstitial quartz appears to be more frequent in the Transvaal crocidolite seams where much of it is probably due to replacement of crocidolite during the metamorphism suffered by these rocks.

PLATE XII

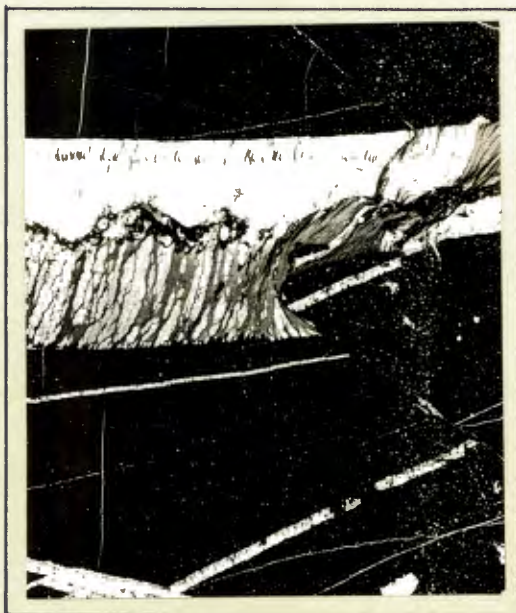

Spec.G66P. Ordinary light,
X $5\frac{1}{2}$ diameters.

A. PARTIAL REPLACEMENT OF
CROCIDOLITE BY QUARTZ

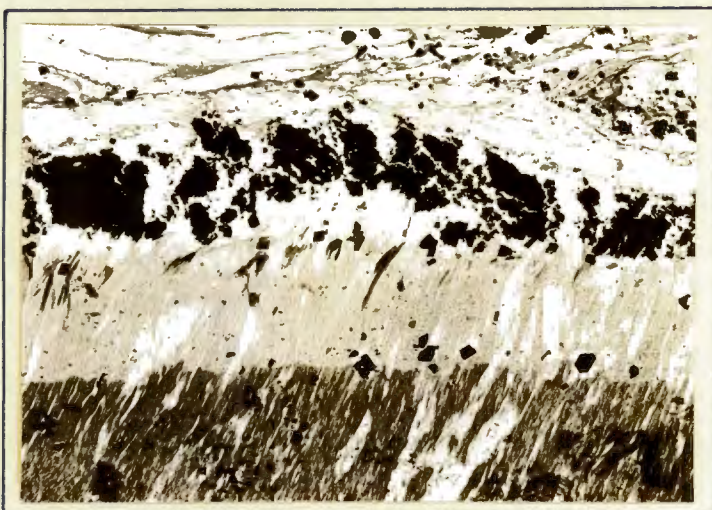

B. CROCIDOLITE - AMOSITE DOUBLET

Spec.G1T, Malips Drift, Tvl.
Ordinary light, X 9 diameters.

Amosite (light grey) capping crocidolite (dark grey) and in turn capped by a magnetite screen (black). Note crystalloblastic magnetite octahedra cutting fibres and interstitial quartz (white).

Amosite fibres frequently occur mixed, or inter-grown with crocidolite in the Pietersburg area of the Transvaal. In some cases the amosite fibres form a capping to the crocidolite fibres, the two kinds of fibre being in crystallographic continuity (Plate XIIB). This results in the handsome doublets and triplets of crocidolite and amosite frequently seen in the Main Horizon reefs at Malips Drift. When the amosite is intimately mixed with crocidolite in the same seam, various shades of "Lavender-blue" asbestos result.

In some seams, pyrite, as cubic crystalloblasts or crystalline aggregates, replaces the crocidolite fibres. These pyrite replacements are more common at or near the contact of the crocidolite seam with the wall rocks. Such replacements were seen in fibre from the Stofbakkies, Glen-Allen and Dikberg Mines in the Prieska area. At Stofbakkies Mine, the fibre seams immediately above the fresh zone are completely replaced by a soft, black mud, carrying numerous cubes of pyrite. The mud still retains the original cross-fibre structure of the seams. The wall-rocks are also much altered to dark muddy material containing numerous cubes of pyrite. It is thought that this alteration is due to reducing, sulphide liquors, which removed and replaced both the crocidolite and the chert with ferrous muds and pyrite. The black material oxidises to a talcose brown mud within two days of exposure to air at surface.

Nontronite, a yellow-green, iron-bearing montmorillonitic clay occasionally forms partings or occurs moulded on fibres in near-surface seams. This impurity occurs only in the weathered zone.

The yellow-brown crocidolite pseudomorph, griqualandite, which discolours much of the fibre mined near surface, cannot rightly be classed as an impurity since it is formed in situ by the weathering of crocidolite.

Inclined and kinked fibres:

In crocidolite seams the fibres, though mutually parallel, assume all angles between perpendicular and nearly parallel to the seam contacts. The latter type is termed "slip-fibre" and is frequently different in character from the fibre inclined at high angles to the seam contact. The slip-fibre appears to be harsher and more brittle and is probably partially recrystallised to needle riebeckite. Analysis 8, Table No.1, shows that slip-fibre contains much less soda than crocidolite. The soda content of 2.06% compares with the 2.89% Na_2O found in cross-cutting veins of recrystallised crocidolite (p.21).

In most examples of inclined fibre, i.e. fibres inclined at an angle to the seam contacts, the direction of inclination for the various seams within a reef is not constant. Successive seams may show the fibre inclined in opposite directions. In a number of cases only a portion of the width of the seam is inclined. At the one contact the fibres are perpendicular to the wall while at the other they are inclined. The seam then shows a definite kink, usually parallel to the contacts, along which the fibres change attitude. This kinking may develop to a stage where both portions of the seam contain fibres inclined to the contact, but with opposite directions of inclination. Sometimes in such doubly inclined seams, there is no definite kink in the fibres, instead they are bent in a gentle curve. The following sketches illustrate these various attitudes.

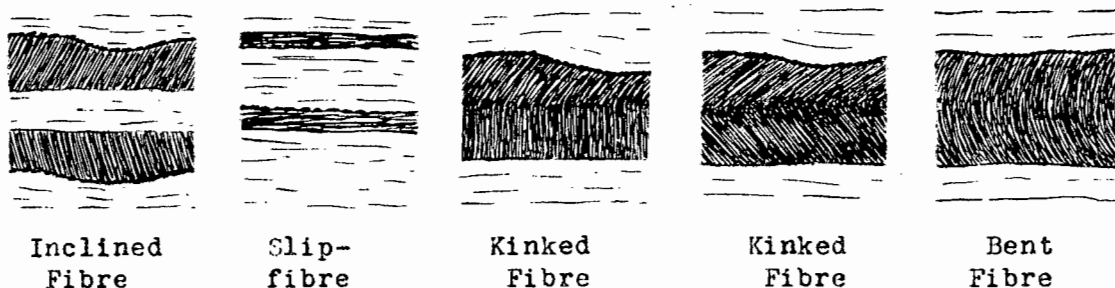

Fig.6. Sketch illustrating the various attitudes assumed by crocidolite fibres.

It is thought that these attitudes of the fibres are due to vertical pressure applied to the seams after fibre development. The finely fibrous nature of the crocidolite facilitates their formation. Similar structures would be developed in a pack of cards if it were held firmly at both ends while vertical pressure was applied. The extreme case of inclination, i.e. slip-fibre, appears to be the result of horizontal differential pressure, i.e. shearing stress, acting in conjunction with the vertical pressure. A small horizontal shearing stress component also played a part in the development of low angle, singly inclined, seams. A certain amount of recrystallisation, especially in the case of slip-fibre, probably takes place in order to accommodate the crocidolite in the reduced volume occupied by the inclined seam.

In many cases where the reef strata are folded, different periods of folding can sometimes be distinguished. The relation of crocidolite to a period of folding prior to the formation of the cross-fibres has already been mentioned. Of more frequent occurrence are folds which post-date the formation of the cross-fibre seams. Most of the strata behaved incompetently but the crocidolite seams either brecciated, as illustrated in the frontispiece Plate, or the fibres were inclined to the seam contacts. Plate VIIIB (p.28) shows an extreme case of overfolding resulting in a small scale nappé structure and the development of slip-fibre in the shear planes. At Klipfontein and also at Orange View in the Prieska area, the crocidolite horizons suffered much of this type of overfolding. The resulting shearing stresses caused the development of numerous low angle, singly inclined, seams. The stresses also caused recrystallisation in the mass-fibre beds, giving rise to thin flake-like patches of slip-fibre along the shear planes. These patches bear a slight resemblance to mica flakes as seen on a bedding plane in mica schist. In specimen G51a.P. from Orange View the shearing took place after the partial silicification of the seam and affected only the lower portion of the seam.

Post induration folding, resulting in the brecciation of the chert bands and the formation of a cavity in the crest of the fold, was seen in only one case, specimen No. G55D from the Kuruman area, illustrated in Plate XIII. The crocidolite seams were extensively brecciated and displaced, but failed to develop either inclinations or slip-fibre, probably because of the rigidity of the host-rock.

Inclinations or kinks in the fibre results in an enhanced fibre-length to seam-thickness ratio. Provided the fibre is not partially recrystallised and hardened, inclined fibre should be taken into account when assessing reef values since much thinner seams than usual can be recovered during milling.

Weathering and Silicification

In contrast to its host rocks, crocidolite appears to be remarkably resistant to weathering and often persists right to surface with little obvious deterioration in quality. There is, however, a considerable variation in the blue colour of the crocidolite. Fibre from the deeper mine workings in the Cape Province has a dark steely blue colour, whereas fibre from the weathered zone is lighter, lavender-blue in colour. Chemically the crocidolite from the weathered zone appears to have slightly less silica, more ferric iron and more bound water, i.e. water liberated above 105°C than that from the fresh zone. In Table No.2 it will be seen that the ratio of $Fe^{++}/Fe^{++} + Fe^{+++}$ in the empirical formula falls below 0.55 to 1 in crocidolite from the weathered zone. The older published analyses of crocidolite all show a lower soda content than most modern analyses. Since all the older analyses were carried out on samples from the weathered zone, it may be inferred that soda decreases upon weathering. Analyses 4 and 5 in Table No.1, however, do not show this decrease of soda content in the weathered zone.

PLATE XIII



POST INDURATION FOLDING OF
A CROCIDOLITE SEAM

Spec.G55D. Natural size.

Note brecciation of chert bands
(light grey) and crocidolite seam
(dark grey to black). Central
cavity with quartz crystals below
(black) crocidolite seam.

The increased pore space, up to 15%, in the crocidolite seams from the weathered zone results in the fluffy, easily teased, condition usually associated with crocidolite. The gradual reduction of pore space as the fresh zone is approached and the consequent harsh and compact appearance of the crocidolite led du Toit (1945) to postulate that, even though crocidolite may retain its essentially fibrous nature with increasing depth, it would lose its valuable property, i.e. that of being capable of teasing out to the finest fibres. Subsequent mining and testing of crocidolite from the fresh zone has shown that there is, on the contrary, a marked improvement in the quality of the fibre with increased depth. In fact, fibre of excellent quality has been intersected in boreholes at depths appreciably greater than 1000 feet below the lower contact of the weathered zone (Cilliers - personal communication).

Under extreme conditions of weathering crocidolite is oxidised and hydrated to its yellow-brown pseudomorph, griqualandite, which consists essentially of goethite and a little silica (Hall, 1930). Griqualandite may be found at considerable depths below surface in the weathered zone where oxygenated surface waters had access to the crocidolite seams, such as along faulted or brecciated zones. The griqualandite has no commercial value, in fact great care has to be exercised to eliminate this easily powdered material from the ore since it causes an unsightly discolouration in the milled blue fibre.

In high rainfall areas the weathering of crocidolite may proceed beyond the griqualandite stage, only a red limonitic mud remaining in place of the crocidolite.

In areas of low rainfall, where the effects of surface silicification are appreciable, the griqualandite is silicified to "tiger-eye". In certain cases, all the goethite may be replaced by silica, in which event the griqualandite is changed to a seam of milky, fibrous quartz.

Silicification of crocidolite may also take place at considerable depths (silicified seams were found at 300 to 400 feet below surface, in a drill hole near Heuningvlei, Vryburg District), but in such cases the silicification is not due to weathering. Bundles of crocidolite fibres within a seam become pseudomorphously replaced by silica, each bundle being replaced as a unit. The resulting, coarsely fibrous, siliceous pseudomorph appears to retain the finely fibrous structure and vivid blue colour of the original crocidolite due to inclusions of unreplaced riebeckite fibres in the quartz (Plate XIIA, p.31). This "bundle" type of replacement is in accordance with the observations of Thiesmeyer (1937) in the Virginia tremolite asbestos deposits. The silicification may affect half of the seam only, the other portion retaining its finely fibrous nature.

IV. PRECAMBRIAN BANDED IRONSTONES

(a) The term "banded ironstone"

In South Africa the term "banded ironstone" is used to describe thinly bedded or laminated, chemical sediments containing 15% or more iron as oxide, silicate or carbonate. James (1954, p.239) suggested the name "iron formation" or "iron-bearing formation" for this type of rock. It is exemplified by the "slatey iron-formation", "carbonate slate", "ferruginous slate" or "taconite" of the Lake Superior Region. The term includes such rocks as the "itabirites" of South America, the "banded hematite quartzite" of India, the "banded ferruginous chert" or "jasper bars" of Australia and the "quartz banded (iron) ores" of Sweden.

For the purposes of this thesis, the South African term "banded ironstone" will be retained, since it is considered to be the most descriptive of the rocks in question.

(b) General geology of banded ironstones

The banded ironstones of the Precambrian are markedly similar in their lithology and stratigraphic associations. Formations containing banded ironstones usually consist of a basal conglomerate and/or relatively clean quartzite lying on earlier formations with a marked unconformity. The basal members are conformably overlain by thick dolomite or dolomitic limestone which in turn grade through shaley or arenaceous rocks into the banded ironstone. Graywackes, shales, basic lavas and thin, localised, banded ironstone beds end the sequence.

This sedimentary sequence, with minor variations, has been described for formations containing banded ironstones in South Africa (du Toit, 1954, pp.127-163), in North America (Tyler and Twenhofel, 1952), South America, where the dolomite usually underlying the banded ironstone

is absent (Guild, 1957), and in Western Australia (Miles, 1942). The similarities both in stratigraphy and mineralogy (except for the occurrence of crocidolite in South Africa) between the North American and South African banded ironstones are especially marked.

Banded ironstones also occur as remnants in a number of continental shields. They are usually much metamorphosed and deformed and the stratigraphical sequence is not always clear. MacGregor (1941) records the association of dolomite (with concretionary structures believed to be of algal origin), banded ironstone, arkose and conglomerate with basic lava (showing pillow-structure) in the Bulawayan System of Southern Rhodesia. In the Canadian Shield on Belcher Islands in the Hudson Bay banded ironstone forms the topmost member of a sequence of shale, quartzite, limestone and banded ironstone. The whole sequence is sandwiched between two thick layers of basic lavas (Bruce, 1945, pp.592-3). The banded ironstone of this sequence can be divided into two zones, the upper consisting of 120 feet of chert with iron oxides, and the lower, containing 245 feet of chert bands interlayered with iron oxides, numerous green ferrous silicate bands and scattered siderite rhombs. The similarity to the lowermost two divisions of the Lower Griquatown Stage (p.63) is noteworthy.

(c) Lithology and mineralogy of banded ironstones

1. The fresh rocks

With increasing depth below surface the prominent yellow, brown and red tints of banded ironstones in the weathered zone are replaced by cream, metallic grey, blue, green, olive and black colours. These dark colours are due to the predominantly ferrous condition of the iron in the minerals contained in the rocks.

The fresh rocks are finely laminated and consist of iron oxides, various hydrous iron silicates and iron-rich carbonates set in chert matrixes or alternating as relatively monomineralic bands interlayered with chert bands. The iron minerals normally present in the fresh rocks are:-

Oxides

Magnetite: (Fe_3O_4) as euhedral octahedra. The magnetite contains minor amounts of Cr, Ti, Mn, Al and Mg.

Hematite: ($\alpha - \text{Fe}_2\text{O}_3$) occurs frequently in the weathered zone in the rhombohedral form as specularite. It also occurs as dusty inclusions in chert to form the so-called jaspers. Oolitic hematite is found in some banded ironstones, but in the Cape Province it only occurs in the upper portion of the Dolomite Series.

Maghemite: ($\gamma - \text{Fe}_2\text{O}_3$) is the name for γ hematite, which has a cubic, spinel-like structure and is magnetic. There appears to be a whole series of maghemites between the end members magnetite, Fe_3O_4 , and maghemite, $\gamma - \text{Fe}_2\text{O}_3$, (Smith, 1958, p.5). In polished section magnetite and maghemite appear similar and their X-ray diffraction patterns are much the same. Hagg (1935) and others found that the cell edges of maghemites are smaller than magnetites. This reduction in unit cell dimensions is related to the fact that the ferric iron occupies less space than the ferrous iron. The name, martite, was used at one time to designate maghemite but it is now used for α - hematite pseudomorphous after magnetite or maghemite (Gruner, 1926.a.).

Silicates

Greenalite, an iron serpentine (Gruner, 1936), with the formula

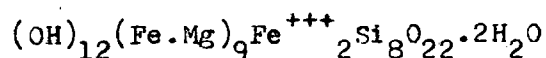

is a greenish to brownish coloured, nearly isotropic, mineral with

a refractive index of 1.65 to 1.67. It generally occurs as granules, similar to glauconite. It is an important constituent of the banded ironstones in North America but was not found in any of the South African specimens examined.

Stilpnomelane has a variable composition:

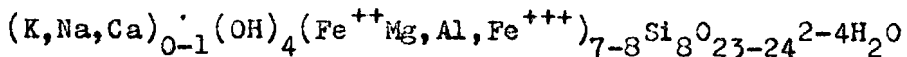

The structure (Gruner, 1944.a.; and Hutton, 1938) appears to be both talc-like and mica-like, but with extra FeO and H₂O. It has base exchange and hydration properties similar to montmorillonite and thus contains variable amounts of alkali and water, loosely held between layers. The Fe⁺⁺⁺/Fe⁺⁺ ratio is also highly variable. Ferro-stilpnomelane with low Fe⁺⁺⁺/Fe⁺⁺ ratio is deep green in colour and is pleochroic, pale yellow to green. Ferri-stilpnomelane with high Fe⁺⁺⁺/Fe⁺⁺ is dark brown to reddish-brown, nearly opaque. Refractive indices vary from 1.551 - 1.625 for α and 1.594 - 1.735 for γ, and the birefringence, 0.043 - 0.110 (Hutton, 1938, p.182). The refractive indices increase with the Fe⁺⁺⁺/Fe⁺⁺ ratio and with decrease in K content (Hutton, loc.cit., p.188). The 2V is very small, the mineral being nearly uniaxial, negative.

Minnesotaite: Gruner (1944.b.) established the identity of minnesotaite. It is an iron-bearing talc with the composition

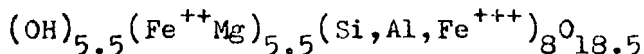

Smith (1958, p.49), gives the ideal composition as H₄Fe⁺⁺₆Si₈O₂₄ which is the ideal talc formula with complete substitution of Mg by Fe⁺⁺. It generally occurs fibrous and can easily be mistaken for sericite under the microscope. It has parallel extinction and positive elongation. It is optically negative with a very small 2V and with the BX_a perpendicular to the basal cleavage. The refractive indices

(Gruner, 1944.b.) are $\alpha = 1.580$; $\gamma = 1.615$ and birefringence = 0.035. Richarz (1927.a.) gives $\gamma = 1.623$ with $\gamma - \alpha = .04 - .05$.

Carbonates

The iron-rich carbonates belong to two mineralogical series. They are: Siderite, FeCO_3 and Ferrodolomite, $\text{Ca.Fe}(\text{CO}_3)_2$. The isomorphous replacements in the two series are:

Mg, Mn in large amounts and minor amounts of Ca, Sr, Ba, Pb, etc. replacing Fe in both series, and

Sr, Ba, Mn, Mg, Fe, Pb, etc. replacing Ca in small amounts in ferro-dolomite.

Siderite usually occurs with some Mg substituting for Fe and a full series probably extends between FeCO_3 and MgCO_3 . A similar series may extend to MnCO_3 , but there are not many mineral representatives between the end types. There is practically no solid solution between FeCO_3 and CaCO_3 (Calcite), but a continuous series between CaCO_3 and MnCO_3 does exist.

The siderite in banded ironstones contains as much as 10% or 15% MgCO_3 (Gruner, 1946) and variable amounts of MnCO_3 .

Ferrodolomite: Pure ferrodolomite is unknown, but according to Winchell (1951, p.114), Fe and/or Mn replaces Mg up to about 50 mol. percent in dolomite ($\text{Ca.Mg}(\text{CO}_3)_2$). He assumes linear relations between refractive indices and composition in the dolomite minerals.

Ankerite is the mineral name used for the dolomitic carbonate containing equal mol. fractions of the iron and magnesium end members. It usually contains small amounts of manganese as well.

Other iron silicates, such as the chlorite, thuringite, and the amphiboles, grunerite and riebeckite, the pyroxenes hedenbergite and acmite, or even the iron-olivine, fayalite, may occur, depending on the grade of metamorphism suffered by the rocks.

2. Weathering and silicification

Because of their peculiar composition and physical constitution, banded ironstones are particularly sensitive to mineral change under not only dynamic and thermal action but also the normal agencies of weathering. Extensive changes occur during oxidation, hydration and silicification, and an entirely false impression of the original constitution of the rock is gained from specimens taken on outcrop or from shallow depths. In South Africa, weathering of the banded ironstones is widespread and extends to surprising depths. It is only at depths in excess of 100-200 feet below surface that fresh rocks are encountered. In some areas the effects of oxidation and hydration can even be traced to depths of nearly 300 feet below surface.

Silicification affects only the upper portion of this weathered zone. The depth and extent of silicification is dependent to a large measure on the annual rainfall of the area. Du Toit (1945, p.165) is of the opinion that, in areas with an annual rainfall in excess of 15 inches, silicification plays a very minor role, the surface rocks being extensively leached. He divides the weathered zone into two parts. (op.cit, p.167), (i) the leached zone, in which the effects of oxidation and hydration become increasingly apparent and the rock softens or becomes friable due to leaching out of materials by meteoric waters, and, (ii) the silicified zone, in which the soft leached rocks harden up again by cementation with silica.

The South African banded ironstones are represented on outcrop by bands of magnetite, hematite, or goethite and chert or microcrystalline quartz. The chert bands usually contain dustings of finely divided hematite (red jasper) or goethite (yellow to brown jasper), the latter being the more common. In areas of high rainfall where virtually no silicification occurs at surface, such as in the Transvaal, the banded ironstone is composed of bands of friable, yellow chert and hydrated iron oxides. In Brazil, where the rainfall is very

high, the goethite in the yellow chert is also leached out, leaving a clean white friable rock (Guild, 1957). In low rainfall areas, such as the Northern Cape and certain parts of India, outcrops are extensively silicified and the banded ironstone is composed of hematite bands in brown to red jasper.

3. The Sedimentary facies of banded ironstones

James (1954) in a study of the relatively unmetamorphosed, fresh rocks of the Lake Superior region was able to divide banded ironstones into four distinct sedimentary facies on the basis of the dominant original iron mineral. These are:-

1. The sulphide facies represented by black slates in which pyrite makes up as much as 40% of the rock. The free-carbon content of these rocks typically ranges from 5% to 15%.
2. The carbonate facies consisting in its purer form of interbedded siderite and chert.
3. The oxide facies consisting of two principal types, one characterised by magnetite and the other by hematite. The magnetite type is the dominant lithology of both the Lake Superior and the South African banded ironstones. It may be far more widespread, but in most other countries the available descriptions are of the surface rocks in which extensive oxidation changes have taken place. The magnetite-banded rocks consist typically of magnetite interlayered with chert, carbonate or iron silicates or combinations of the three. The hematite-banded rocks consist of finely crystalline hematite interlayered with chert or jasper. The hematite also commonly occurs as oolites in these rocks.

4. The silicate facies contains one or more of the hydrous ferrous silicates, greenalite, stilpnomelane, minnesotaite or chlorite as a major constituent. Granule structure, similar to that of glauconite may occur in some of the greenalite bearing varieties. The most common associates of the silicate rocks are either the carbonate or the magnetite bearing rocks.

The principal features of the banded ironstone facies are summed up in Table No.5 (James, 1954, p.249, Table 1):-

As might be expected, the lithologies encountered in the field are far more complex than the simplified end-members given in Table No.5. Many of the rocks were deposited in fluctuating environments with resultant interlayering and modification of the end-members, while others were strongly modified by later diagenesis under chemical environments much different from those existing during deposition.

4. Metamorphism of banded ironstones

James (1955) made an exhaustive study of the effects of regional metamorphism on the Iron Formation in Northern Michigan. He found that the zones of metamorphic intensity can be delineated by chlorite, biotite, garnet, staurolite and sillimanite isograds or their equivalents similar to the classic areas of the Scottish Highlands. The metamorphism is however unusual in that it is not synchronous with the deformation. James (loc.cit. p.1461) suggests that the term "regional thermal metamorphism" would be more appropriate for the area studied.

Assuming that pyrite, siderite, greenalite, chlorite, hematite and magnetite are original constituents, relatively few new phases are developed in many types of banded ironstone. Much of the metamorphic energy is expended instead on a general coarsening of the grain size of the original minerals. Minerals of metamorphic origin

TABLE NO. 5.

Facies	Sulphide	Carbonate	Silicate		Oxide	
			Non-granular	Granular	Magnetite	Hematite
Lithology	Laminated to thin banded black, pyritic carbonaceous slate. Chert rare.	Thin bedded to laminated rock consisting of alternating layers of grey chert and carbonate	Laminated light green to greenish black rock. Chert rare.	Massive dark green rock with irregular bedding marked by layers of chert and magnetite.	Dark, thin bedded to irregularly bedded rock consisting of layers of magnetite alternating with layers of dark chert, green silicates, or silicates plus carbon.	Thin bedded to irregularly bedded rock consisting of alternate layers of crystalline hematite and grey chert or reddish jasper.
Principal iron mineral	Pyrite	Iron-rich carbonate	Iron silicate (Minnesotaitite stilpnomelane chlorite)	Iron Silicate (Greenalite minnesotaitite stilpnomelane)	Magnetite	Crystalline hematite
Subsidiary iron minerals (rarer minerals in parentheses)	Carbonate (Greenalite)	Pyrite Stilpnomelane Minnesotaitite Magnetite (Hematite)	Carbonate Magnetite	Magnetite Carbonate Hematite	Greenalite Minnesotaitite Stilpnomelane Carbonate (Pyrite)	Magnetite (Carbonate)
Percentage range of metallic iron content	15 - 25	20 - 35	20 - 30	20 - 30	25 - 35	30 - 40
Distinctive features	"graphitic"	Stylolites common	Laminated Structure	granule-bearing	strongly magnetic	Commonly Colitic
Environment of origin	Strongly reducing anaerobic	Reducing	Variable but typically mildly reducing	Mildly oxidising to mildly reducing.	Mildly oxidising to mildly reducing.	Strongly oxidising

are grunerite, epidote, garnet, hornblende, pyroxene with some magnetite, and fayalite (within the metamorphic aureole of the Duluth Gabbro in the Mesabi range). Stilpnomelane, minnesotaite and chlorite may be regarded as metamorphic in their present form in some rocks. They may, however, have developed from pre-existing silicate materials during the diagenesis - lithification period and then been recrystallised during metamorphism. Simple increase in grain size is the most obvious metamorphic effect in the banded ironstone and is most easily observed in the chert layers. James notes (loc.cit. p.1473) that associated minerals in the chert layers have a pronounced effect on the final grain-size of the chert. Dispersed silicates, for example, result in a reduced grain size in relation to adjacent pure chert layers. He sums up the various mineralogical changes which the principal facies of banded ironstones undergo at the various metamorphic grades in the following Table No.6 (p.1475, Table 6).

The metamorphism of the banded ironstone of the Transvaal System in the Union of South Africa is markedly similar to that of Michigan. In the Cape Province, the metamorphism is of a low grade, the mineral assemblages, with the exception of the riebeckite, belonging to the chlorite zone. The usual quartz grain size is of the order of 0.05 mm. The thermal metamorphism of the rocks pre-dates the strong post-Matsap deformation, but post-dates the outpourings of Middle Griquatown lavas and the emplacement of their associated sills as is indicated by the marked alteration of the latter to chlorite-epidote-albite-amphibole rocks. In the Transvaal, the metamorphism was of intermediate grade, as indicated by the frequent occurrence of grunerite. The quartz grain sizes are of the order of 0.10 mm. As in the Cape, the thermal metamorphism probably pre-dates the major deformation of the rocks.

Miles (1946) studied the mineralogy of the metamorphosed Jasper Bars in the basement complex of Southwestern Australia. All gradations from the intermediate grade with banded grunerite-magnetite-

TABLE NO. 6.

SEDIMENTARY		METAMORPHIC		
FACIES	COMPOSITION	(CHLORITE-BIOTITE) LOW GRADE	(GARNET-STAUROLITE) INTERMEDIATE	(SILLIMANITE) HIGH GRADE
Sulphide	Ferrous sulphide Organic carbon "clay"	PYRITE CARBON (Amorphous) QUARTZ Sericite	PYRITE GRAPHITE QUARTZ Micas Garnet (rare)	PYRITE GRAPHITE Pyrrhotite ? Micas Garnet
Carbonate	Carbonate Chert Greenalite	CARBONATE QUARTZ Stilpnomelane Minnesotaitite	GRUNERITE QUARTZ Magnetite Carbonate	GRUNERITE QUARTZ Magnetite Pyroxene
Silicate	Non-clastic	Greenalite Chert Carbonate Magnetite	MINNESOTAITE STILPNOMELANE QUARTZ CARBONATE Magnetite	GRUNERITE QUARTZ Magnetite Pyroxene
	Partly clastic	Iron-rich clay Chert. Carbonate Magnetite ?	CHLORITE STILPNOMELANE QUARTZ CARBONATE MAGNETITE Biotite Mica	GRUNERITE QUARTZ MAGNETITE EPIDOTE GARNET Carbonate Pyroxene
Oxide	Magnetite banded	Magnetite Carbonate Greenalite Chert	MAGNETITE STILPNOMELANE MINNESOTAITE CARBONATE QUARTZ	MAGNETITE GRUNERITE QUARTZ Garnet Pyroxene Garnet
	Hematite banded	Ferric oxide Chert Magnetite Calcite	HEMATITE QUARTZ Magnetite Calcite	SPECULAR HEMATITE QUARTZ Magnetite Calcite SPECULAR HEMATITE QUARTZ Magnetite Calcite
Diameter of typical quartz grains in relatively pure chert layers.		Less than 0.10 mm.	0.1 to 0.20 mm.	More than 0.20 mm.

(Major constituents shown in upper-case letters)

chert or quartzite, through magnetite-grunerite-hedenbergite quartzite to the high grade fayalite-hedenbergite-grunerite-quartzite are described. Where impurities such as magnesia, lime and alumina were present in the original banded ironstone, minerals such as hypersthene, actinolite, hornblende and garnet, were formed. As is the case in the thermal metamorphism of the South African and North American banded ironstones, no evidence of concurrent deformation could be found. Only in the Mt. Windarra area do the grunerite crystals show strong preferred orientations, indicating crystallisation under directed pressure. A similar preferred orientation is present in some of the Transvaal needle riebeckite rocks (Plate XIB, p.31), but in these rocks the orientation is due to the formation of the needle-riebeckite by recrystallisation of the highly orientated crocidolite fibres.

In Western Australia, the banded ironstone of the Nullagine Series suffered only mild low-grade (chlorite zone?) metamorphism with the consequent development of crocidolite and the partial recrystallisation of the quartz.

(d) Distribution in space and time

Precambrian banded ironstones are a feature of every continent. On most continents, more than one major period of deposition can usually be distinguished. An earlier, much metamorphosed and deformed banded ironstone, normally in close association or interbedded with altered basic lavas (greenstones), usually occurs in the basement complex. These "older" banded ironstones are amongst the earliest sediments recognised in most continents. They are found, for example, in the Bulawayan System of Southern Rhodesia, the Swaziland System of South Africa, in the Older Greenstone Series of Southwestern Australia, in the Keewatin of Canada and U.S.A. and in the

Archaen of South America. The rocks are of great antiquity. The absolute age of the Bulawayan System is known with a fair degree of certainty to be greater than 2680 million years (Ahrens, 1955, p.159) and may even be of the order of 3000 million years. The age of the Keewatin in America is of the order of 2500 million years or greater (Wilson, 1959).

A second, younger, relatively unmetamorphosed, group of banded ironstones occurs in North America (in the Huronian of the Lake Superior region), in South America (the Minas Series of Minas Gerais, Brazil), and in Western Australia (the Nullagine Series), while in South Africa two such younger groups occur in the Lower Witwatersrand and Transvaal Systems. The banded hematite-quartzites of the Singhbaurm district of India is thought to belong to the "younger" group, but it is not known whether an "older" group occurs in the basement complex.

The absolute ages of these "younger" banded ironstones appear to be of the order of 1,500 - 2,000 million years. The Huronian in North America is considered to be 1650 million years or more in age (Ahrens, 1955, p.163). The age of the Transvaal System is greater than 1950 ± 150 million years (Nicolaysen, et al, 1958). The lead isotope ratios of galena veins cutting the Transvaal System in the Northern Cape give an age of 2350 million years, but this may be too high an estimate (Nicolaysen, 1958, p.160). The Indian banded ironstones are also of the order of 1,500 to 1,600 million years old (Aswathanarayana, 1956). The Nullagine Series of Western Australia is considered to be older than the Mosquito granite which has an absolute age of the order of 1200 million years (Collins, 1954).

Banded ironstones which have not been classified as above are the highly metamorphosed, 1700 million year old (Tilton and Davis, 1959) remnants, which occur in the basement complex of Sweden (Magnusson, 1936), those of Krivoy Rog, U.S.S.R. (Dzhedzalov, 1958; Svitalsky, 1937) and Central China (Pei-chen, 1960; Tegengren, 1921).

It would appear that on most continents two banded ironstone bearing formations were deposited at an interval of some 1,000 million years apart. In South Africa, at least three periods of banded ironstone deposition can be recognised. These events all occurred before approximately 2000 million years ago. It is significant that no banded ironstones such as defined on p.38 have been found to be less than 1000 million years old. All younger, i.e. post-Cambrian, iron-bearing formations differ completely from the Precambrian banded ironstones.

(e) South African banded ironstones

1. Distribution and correlation:

In Southern Africa the geological Systems which either contain or can be correlated with those containing banded ironstones are:-

The Bulawayan and Lomagundi Systems of Southern Rhodesia,
 The Swaziland, Kheis, Lower Witwatersrand, Transvaal and
 Kaigas Systems in the Union of South Africa, and
 The Damara (?) and Otavi Systems of South West Africa.

The "older" banded ironstones

Representatives of this group occur in the Bulawayan System of Southern Rhodesia and in the Swaziland and Kheis Systems of the Union of South Africa. In Rhodesia, both the Sebakwian and Shamvian Systems, which respectively under- and overlie the Bulawayan System, contain minor banded ironstone beds (du Toit, 1954, p.31).

In the Barberton mountain lands the middle member of the Swaziland System, the Figtree Series, contains banded ironstones. Similar rocks outcrop at Piet Retief and along the Tugela River in Natal.

In the Northern Cape, between Mafeking and Vryburg, the Kraaipan Formation outcrops in a number of elongate belts (refer to Plate I). It lies unconformably on granite-gneiss, contains banded ironstone, and is correlated with the Figtree Series of the Swaziland System.

The Kheis System, outcropping in a northwest striking synclinerium along the Orange River between Prieska and Upington, is also correlated with the Swaziland System. It contains metamorphosed banded ironstones in the lower portions. Similar rocks in "old" granite in the Northern Transvaal, near the Rhodesian border, the so-called Messina Formation, were previously correlated with the Swaziland System. These rocks have recently been shown to be of Transvaal age by means of radio-active dating (Nicolaysen, 1958). It could be possible that the Kheis System represents the metamorphosed western limb of a major synclinerium of which the Transvaal System forms the eastern limb (Plate I). The granites associated with the Kheis System to the west of Prieska do not all belong to the Basement Complex, since ages of the order of 1000 million years have been found for a number of them (Nicolaysen, personal communication).

The writer did not inspect any of the "older" banded ironstones and very little is known about their individual lithologies. The Rhodesian members are described by MacGregor (1941) and in various Southern Rhodesian Geological Survey Bulletins. The Swaziland banded ironstone was described by Hall (1918) and Urie (1958). The Kraaipan Formation and the lower portion of the Kheis System, the so-called Marydale beds, were described respectively by du Toit (1905, 1907) and Rogers and du Toit (1908).

Banded ironstones in the Lower Witwatersrand System

Beds of banded ironstone and magnetic shale occur in the Hospital Hill, Government and Jeppestown Series of the Lower Witwatersrand System. They are usually associated with pyrite-bearing, chloritic mudstones, dark coloured graded silty shales, graywackes and basic lavas. The banded ironstone beds consist of typical, finely laminated alternations of chert, magnetite and carbonate or silicate minerals. The magnetic shales consist of scattered euhedral magnetite crystals, angular quartz shards and fresh sodic plagioclase fragments in a fine-grained chloritic matrix. In one specimen, tufts of fibrous riebeckite were found in the coarser, silt-sized, siliceous portion of a chloritic shale.

Banded ironstones in the Transvaal System

In South Africa the so-called "younger" group of Precambrian banded ironstones is present in the Transvaal System. The Banded Ironstone Zone of the System outcrops in a great arc from 25 miles south of Prieska in the Northern Cape, through the eastern part of the Bechuanaland Protectorate and the Northern Transvaal to near Lydenburg in the Eastern Transvaal. Its distribution in the Northern Cape is shown in Plate I.

The economically important crocidolite horizons is confined to the Banded Ironstone Zone of this System, which is described in greater detail in the following Chapter.

V. THE BANDED IRONSTONES OF THE TRANSVAAL SYSTEM

(a) General Geology of the Transvaal System

In the Transvaal and the Northern Cape Province, the Transvaal System can be divided into three series. These are: the Black Reef Series at the base, the Dolomite Series in the middle and the Pretoria Series at the top. In the Northwestern Cape, however, the System is thought to consist of two formations only, the Kaigas containing dolomite or dolomitic limestone with subordinate tillite and the Numees, consisting almost entirely of tillite (De Villiers and Söhnge, 1959, p.137).

The Black Reef Series is composed of coarse arenites and small pebble conglomerates, which are very dark, due to the presence of abundant pyritic, chloritic and carbonaceous material. The conglomerates are sometimes auriferous. The top of the Series is distinctly shaley and is conformably overlain by dolomitic limestone of the Dolomite Series.

The Dolomite Series is composed of up to 7000 feet thickness of well bedded, blue grey, magnesian limestone with subordinate bands of chert. The latter are usually present as layers following the bedding and are most prevalent in the upper portions of the Series. Occasionally layers of carbonaceous shale, a foot or more thick, are found, as well as layers showing stromatolitic structures, i.e. algal limestones (Young, 1932, 1933, 1934 and 1945). Stromatolitic layers similar to those described by Young have recently been found in drill cores of the Dolomite Series at Leslie in the Eastern Highveld.

As one progresses upwards in the succession, the chert layers, which normally occur near the top of the dolomite, thicken rapidly and become increasingly ferruginous, eventually passing into black, red and

white banded ferruginous rocks, which in turn grade into thinly laminated, banded ironstone. In the Prieska area the upper portions of the dolomite become increasingly shaley, passing upwards through a 50 to 80 feet thick band of thinly bedded shales which become ferruginous in alternating layers near the top. These "passage beds" are overlain by banded ironstone.

Along the southern edge of the Bushveld basin no banded ironstone is exposed, its place being taken by a chert breccia, the so-called Bevet's Conglomerate, which forms the base of the overlying Pretoria Series. The banded ironstone probably extended over the whole basin but was eroded off the southern portion during a period of emergence prior to the deposition of the Pretoria Series. It therefore appears to sub-outcrop along a line extending roughly from Zeerust to Marble Hall and further to the confluence of the Olifants and Steelpoort rivers (Willemsse, 1959, p.xxv).

Over most of the Northern Cape and Northern Transvaal, the Banded Ironstone Zone of the Transvaal System attains a thickness of between 800 and 1000 feet. Towards the Southern Transvaal, it gradually thins out as the postulated sub-outcrop is approached. This thinning may be due to erosion of the upper portions of the Zone during a period of uplift prior to the deposition of the Pretoria Series. In the Prieska area the thickness of nearly 3000 feet attained by the Banded Ironstone Zone is in sharp contrast to its nearly constant thickness of 800 to 1000 feet over most of its exposure length of more than 600 miles.

The characteristic features of banded ironstone which serve to distinguish it from the overlying sediments in both the Cape and the Transvaal are:-

1. The invariable presence of thin bands of magnetite.
2. The complete absence of recognisable detrital materials, and
3. The thinly laminated nature of the rocks.

The banded ironstones of the Transvaal System have been described by Rogers (1906, 1907), du Toit (1906, 1907, 1945 and 1954) and Hall (1918, 1930) amongst others.

The economically important crocidolite horizons described in Chapter III are confined to the Banded Ironstone Zone of the Transvaal System. They occur over the entire exposure length of the Zone in the Cape and the Northern Transvaal. At Malips Drift they grade into amosite horizons, the latter being the dominant type along the northeastern and eastern portions of the Bushveld basin. Here the Banded Ironstone Zone is conformably overlain by dolomite, and is thus included in the Dolomite Series. In the Cape Province no dolomite occurs above the banded ironstone nor is the chert breccia, which is normally taken as the base of the Pretoria Series, developed. It is thus included in the latter Series.

In the Transvaal the Pretoria Series is composed of six distinct members; three thick, typically argillaceous stages and three thinner quartzose ones. It attains thicknesses, exclusive of igneous rocks, of up to 24,000 feet. In addition to the sediments there are also four distinct stages of contemporaneous volcanics. A thin glacial zone is present immediately below the first, the so-called Ongeluk Stage of volcanics.

In the Cape Province the Series is divided into three conformable stages, the Lower, Middle and Upper Griquatown Stages. The Banded Ironstone Zone forms the lowest member of the Lower Griquatown Stage which ends in a glacial zone. In the Danielskuil - Kuruman area there is no break in sedimentation between the banded ironstone

and the overlying detrital sediments, the former becoming gradually less ferruginous and the more cherty upwards, i.e. jaspery. The jaspilites in turn become increasingly sandy just before the glacial zone is reached. In the Prieska area some 2,500 feet of fine-grained shale and dark green chloritic mudstone intervene between the banded ironstone and the glacial zone.

The glacial zone is overlain by 3000 feet of andesitic lavas, which constitute the Middle Griquatown Stage. The lavas were probably extruded subaqueously as indicated by the "pillow" structures found along the Mashowing and Kuruman rivers (du Toit, 1954).

The Upper Griquatown Stage has only been found in a narrow belt to the north-west of Postmasburg, where it apparently overlies the Middle Griquatown Stage conformably. It consists of some 5,000 feet thickness of massive ferruginous cherts and jaspers near the base, pale quartzites, dark slates and blue limestones in the middle, and lavas and tuffs near the top.

If the glacial zone of the Lower Griquatown Stage is correlated with that of the Ongeluk Stage, a stratigraphical comparison, as depicted in Table No.7, can be made between the Cape and Transvaal. The thicknesses ascribed to the various stratigraphical units are all estimated and may be subject to large errors.

Previous to the deposition of the Transvaal System, the older rocks had been worn down to an absolute plane upon which the base of the System everywhere rests evenly and unconformably. The subsequent deposition in the Transvaal was decidedly cyclic (Willemsse, 1959, p.xxiv), each cycle starting with coarse sediments and conglomerates and ending with a period of uplift which resulted either in a shallowing of the basin or actual erosion of the previously deposited sediments. Six such cycles can be recognised. The initial cycle produced banded ironstone shortly before regional uplift ended the cycle.

In the Cape the cyclic deposition of the System is not so obvious. The intra-formational conglomerates and breccias in the Lower Griquatown Stage at Danielskuil and Kuruman may be reflections of the regional uplifts in the Transvaal since they represent short periods of extreme shallowing of the basin of deposition.

(b) Petrography of the Lower Griquatown Stage

Some 180 specimens of rocks occurring in the Lower Griquatown Stage in the Cape Province were examined and more than 100 selected for detailed investigation. The specimens were collected, where possible, from the fresh zone. Since fresh specimens were for the most part only available in crocidolite mines, the petrographic descriptions that follow are perforce of rock-types found in and near the crocidolite horizons.







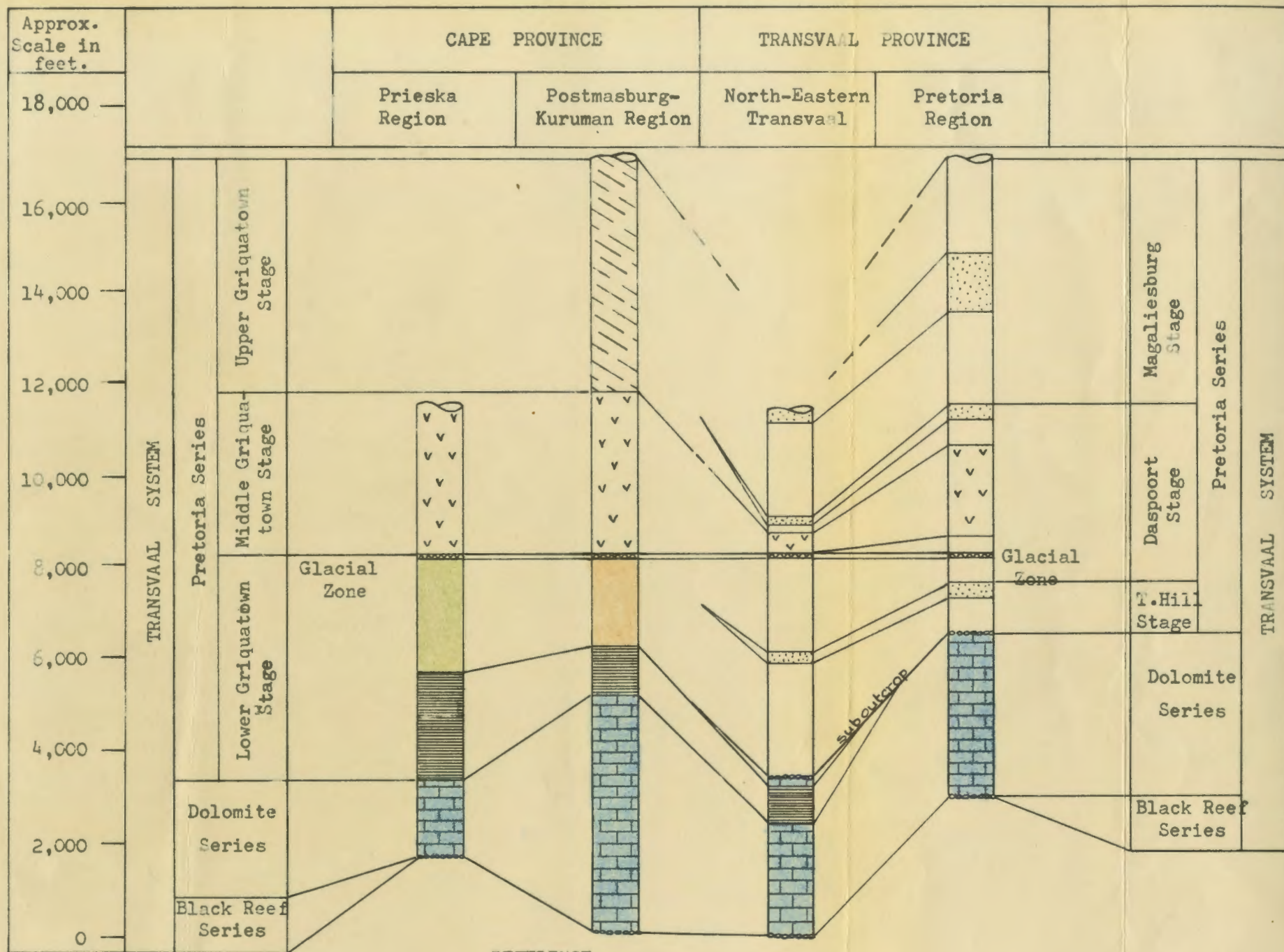



The detailed investigation was carried out by means of microscopic examination of thin sections and mineral grains and by chemical and spectrographic analysis. An additional 20 specimens from the Malips Drift area of the Transvaal and 1 specimen each from Wittenoom Gorge, Western Australia, and Mesabi Range, Minnesota, were included in the investigation for comparison with the Cape specimens.

The Lower Griquatown Stage can be subdivided into three distinct zones, which from the bottom up are: The Banded Ironstone, the Jasper or Mudstone and the Glacial Zones. The contacts between the zones are everywhere gradational, that between the Banded Ironstone and Jasper Zones generally being taken to be above the highest horizon at which crocidolite occurs. The Prieska area is exceptional in that sporadic crocidolite occurs in a chert layer in the Mudstone Zone some 1000 feet above its contact with the Banded Ironstone Zone.

TABLE NO. 7.



REFERENCE

- | | | | | | |
|---|---|---|--------------------|---|---------------------|
|  | Lava, quartzite, shale, chert, limestone, jasper and banded ironstone |  | Shale |  | Banded Ironstone |
|  | Andesitic lava |  | Jasper |  | Dolomitic limestone |
|  | Quartzite |  | Chloritic mudstone |  | Tillite |
| | | | |  | Conglomerate |

1. The Banded Ironstone Zone

This Zone consists of approximately 800 - 1000 feet thickness of thinly laminated rocks. The individual laminae or layers vary in thickness from fractions of a millimetre to a few centimetres, but are generally between 1 and 5 millimetres thick. The contacts between layers are invariably sharp and although the mineralogical composition of each layer remains constant, it changes completely from one layer to the next.

The mineralogy of the rocks is consistent with James' carbonate, non-granular silicate and magnetite facies, denoting mildly oxidising to reducing conditions of deposition (Table No.5.). Strongly reducing conditions were seldom attained as indicated by the rarity of pyrite and free carbon. On the other hand, strongly oxidising conditions were even less prevalent. The iron oxide mineral in the fresh rocks is invariably magnetite, only in the upper portions of the underlying Dolomite Series at Danielskuil were hematite oolites found.

The fresh banded ironstone consists of alternating thin layers of chert, magnetite, stilpnomelane, minnesotaite, riebeckite and carbonate, and layers consisting of mixtures of these minerals in which any one mineral may predominate. It is strikingly coloured in alternating bands of various shades of cream, grey, green, blue and black, depending on the mineralogical composition of the various layers. This colour-banding becomes even more striking as the weathered zone is approached. Certain bands then acquire a brilliant red colouration due to the oxidation of some of the ferrous iron minerals to hematite.

The chert layers, which are the predominating mineralogical type, consist of mosaics of interlocking, clear quartz grains with no preferred orientation. The grain size is of the order of 0.03 to 0.05 mm. There is a progressive increase of grain-size with depth. In the Danielskuil area the quartz grains from the Upper Crocidolite

Horizon average 0.01 mm. less than those from the Main Crocidolite Horizon, approximately 150 - 200 feet lower in the succession. At Prieska, where the zone attains its maximum thickness, the increase of grain size with depth is even more marked. Here the average diameter of quartz grains in the Westerberg Crocidolite Horizon is 0.01 mm. while those of the Lower Crocidolite Horizon, some 2000 feet lower in the succession average 0.05 mm.

Layers composed entirely of chert are extremely rare, they usually contain variable amounts of one or more minerals which may assume such proportions that the quartz becomes the accessory mineral. The most common of these minerals is minnesotaite, which occurs as minute, randomly orientated, crenulated flakes. When examined under crossed nicols they appear as fan-shaped bundles of fibres due to the higher birefringence of the rib-like crenulations on the flakes. These are illustrated in the following sketch:-

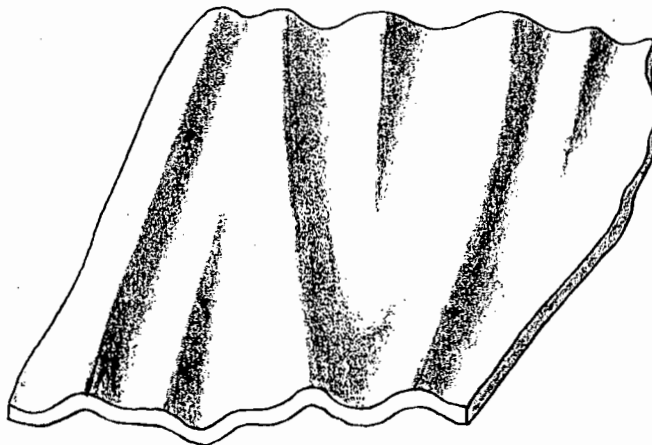

Fig.7. Rib-like crenulations on minnesotaite flakes.

The minnesotaite in specimen G3P from Dikberg, Prieska district, has the following optical properties:-

.BXa nearly perpendicular to the perfect basal cleavage

2V very small, negative.

$\alpha = 1.576$, $\beta = 1.609$, $\gamma = 1.612$

Flaschen and Osborne (1957, p.926) found $\alpha = 1.586$, $\beta = \gamma = 1.618$ for minnesotaite from the Mesabi Range in the Lake Superior region.

The chert-minnesotaite layers frequently contain minute euhedral magnetite crystals, small granular patches of carbonate or stilpnomelane and, rarely, scattered fibres or fibrous clumps of riebeckite.

Numerous chert layers appear speckled in hand specimen. This is due to the presence of relatively large (0.15 - 0.20 mm. along the long diagonal) rhombs of carbonate. Some of these rhombs show the later growth of carbonate over a granular core which may consist either of quartz or of carbonate as illustrated in Plate XIVA. Riebeckite fibres are more prevalent in the chert-carbonate layers where they appear to crystallise preferentially on the carbonate crystals (Plate XIVB and C). Stilpnomelane is also a frequent accessory in these layers.

Pure magnetite layers, apart from those capping the crocidolite seams, are rare. They invariably contain quartz which often shows a strong preferred orientation at right angles to the magnetite surfaces (Plate XVA). Fibrous riebeckite and carbonate granules are frequent accessories. In the barren strata between crocidolite reefs it is usual to find magnetite layers alternating with chert-minnesotaite layers. Riebeckite in such strata is virtually confined to the magnetite layers.

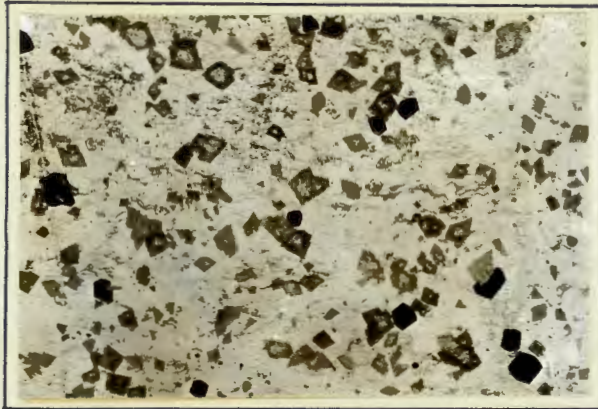

A. CARBONATE RHOMB OVERGROWTHS

Spec.HV16/261. Ordinary light, X 9 diameters.

Most of the carbonate rhomb cores consist of finely granular carbonate. Black crystals consist of pyrite which crystallised later than carbonate.

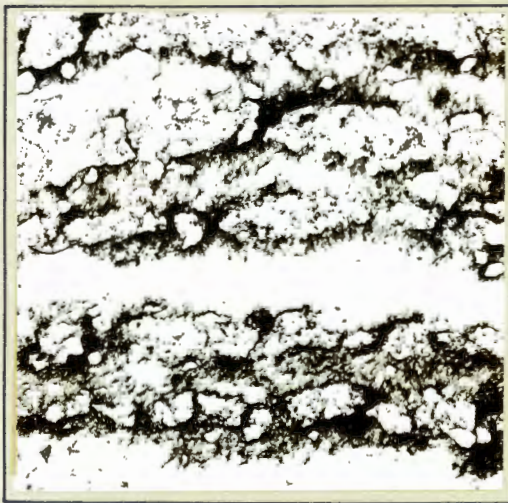

B. FIBROUS RIEBECKITE CRYSTALLISED PREFERENTIALLY ON CARBONATE

Spec.G28D. Ordinary light, X 10 diameters.

Riebeckite fibres (black) virtually confined to carbonate (high relief) layers set in chert (white).

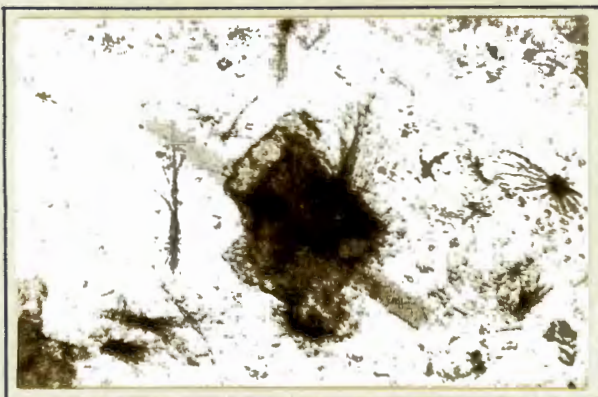

C. DENDRITIC GROWTH OF RIEBECKITE FROM SURFACE OF CARBONATE RHOMB

Spec.G32D. Plane polarised light, X 405 diameters.

Riebeckite fibres (black) growing away from carbonate (dark grey) surfaces and also from submicroscopic nuclei in the chert (white).

PLATE XV

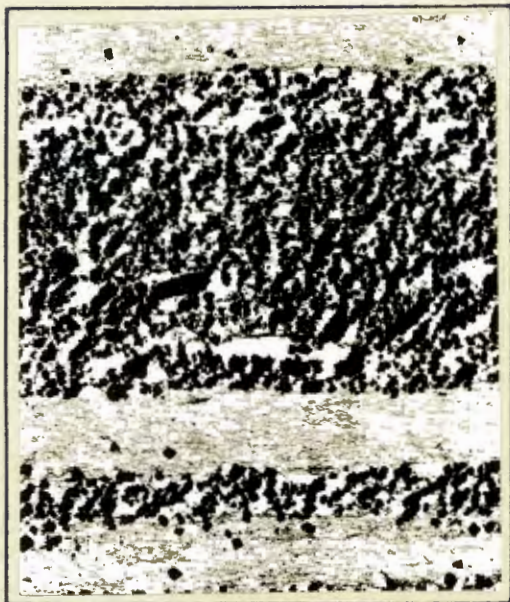

Spec.G1P. Plane polarised light, X 10 diameters.

Magnetite euhedra (black) with interstitial fibrous quartz (white) forming layers in chert-minnesotaite rock (speckled grey).

A. MAGNETITE LAYERS IN CHERT
-MINNESOTAITE ROCK



Spec.G6P. Plane polarised light, X 10 diameters.

Black specks in central micro-bed are composed of carbon. Vein along left hand border of Plate carries quartz (white) and carbonate (high relief) in addition to stilpnomelane.

B. VEINS OF RECRYSTALLISED,
CROSS-FIBRE STILPNOMELANE
IN MICRO-BEDDED STILPNOMELANE

Bands of nearly pure stilpnomelane are frequently found in close association with crocidolite horizons, as described in Chapter III, p.25. In hand specimen the rock is greenish-black, massive and breaks with a subconchoidal fracture. Under the microscope faint micro-bedding, consisting of variations in the amounts of accessory minerals, is revealed. As a rule the stilpnomelane occurs as densely packed, randomly orientated, cryptocrystalline flakes. In certain bands, however, the flakes are partially orientated and the whole mass shows a faint pleochroism. In such bands it is usual to find criss-crossing veinlets of recrystallised stilpnomelane exhibiting a crude cross-fibre orientation (Plate XVB). Recrystallised stilpnomelane from a veinlet in specimen G6P from Dikberg, Prieska district, has the following optical properties:-

BXa nearly perpendicular to the perfect basal cleavage

2V very small, negative

$\alpha = 1.538$

X > Y = Z with

$\beta = 1.578$

X = pale yellow

$\gamma = 1.583$

Y = Z = olive green

The groundmass of the specimen has an aggregate refractive index of 1.565. In certain dilation veinlets which carry quartz and carbonate the green ferro-stilpnomelane has become oxidised to the brown ferri-stilpnomelane variety. That from specimen G6P has the following optical properties:-

BXa perpendicular to basal cleavage

2V virtually zero, negative

$\alpha = 1.584$

X << Y = Z with

$\beta = \gamma = 1.594$

X = golden yellow

Y = Z = deep olive brown

The most frequent accessory in stilpnomelane bands is a dirty, granular carbonate. All gradations from nearly pure stilpnomelane to nearly pure carbonate are found. These layers also contain minor amounts of quartz, euhedral magnetite and pyrite, but riebeckite and minnesotaite are rarely present. The pyrite usually occurs as large euhedral cubes with well-defined pressure shadows of fibrous quartz and carbonate. In some layers the pyrite is associated with minute rod-like particles of carbon as illustrated in Plate XVI.

Two kinds of carbonate layers are found; the granular type associated with stilpnomelane and the rhombic type associated with chert. Refractive index determinations were made on cleavage flakes from a few specimens of the two types of carbonate. The granular type gave values for ϵ' of 1.705 to 1.710, indicating a siderite with approximately 70 mol.% FeCO_3 and minor amounts of MnCO_3 (Winchell, 1951, p.108), while the rhombic type, with values of ω around 1.710 appears to be a ferro-dolomite with approximately 40 mol.% $\text{CaFe}(\text{CO}_3)_2$ (Winchell, 1951, p.115). These conclusions are very tentative since insufficient determinations were made to calculate the average compositions exactly.

Stylolitic intergrowths and brecciated bedding due to pressure solution are frequently found in the granular carbonate layers (Plate XVIIIA). The rhombic type, which tends to be less massive than the former, frequently has carbonate crystals with granular quartz cores. In certain layers, the ferro-dolomite has overgrowths of clear calcite with $\omega = 1.654$.

Although a great number of different combinations of the various types of layers are found, the dominant rock-type of the Banded Ironstone Zone appears to be alternations of chert-minnesotaite and magnetite layers. Riebeckite, which occurs in variable amounts

PLATE XVI

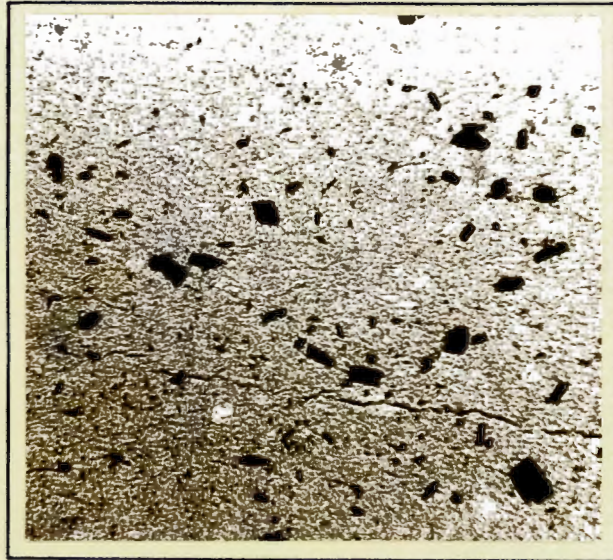

ROD-LIKE CARBON PARTICLES
IN STILPNOMELANE

Spec.G6P, Dikberg Mine, Prieska.
Plane polarised light, X 390 diam.

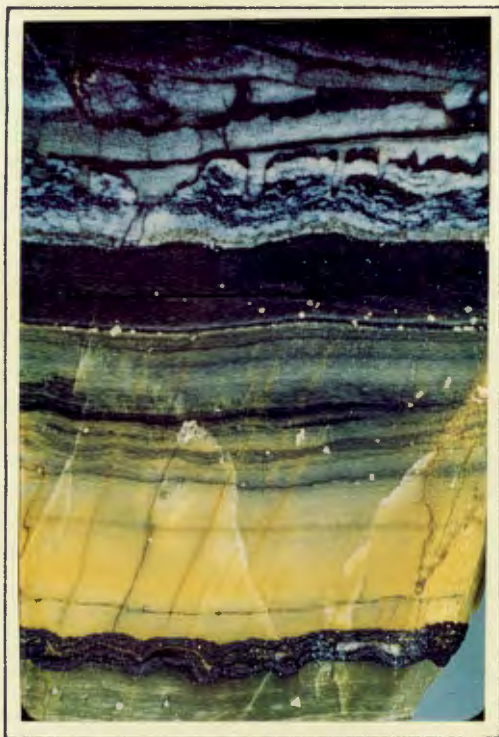

A. GRANULAR CARBONATE LAYERS
SHOWING STYLOLITIC INTER-
GROWTH SET IN BANDED CHERT-
MINNESOTAITE ROCK

Spec. G22P, No. 4 level, Middle
Reef, Dikberg Mine, Prieska.
9/10ths natural size.



B. INTRAFORMATIONAL CHERT BRECCIA

Ouplaas, Danielskuil. 1/6th natural size.

Granular carbonate and ferro-
stilpnomelane with variable
amounts of riebeckite.

Mass-fibre riebeckite.

Chert-minnesotaite with variable
amounts of carbonate and riebeck-
ite and thin magnetite stringers.
Yellow colour of chert due to the
partial weathering of minnesotaite.

Contorted magnetite layers.

(Bright yellow cubes are pyrite
crystals).

throughout the succession, is found in greater concentrations in the riebeckite-bearing beds which also serve as a locus for the crocidolite horizons and the stilpnomelane and granular carbonate layers. It must be borne in mind that most of the sampling was done along the crocidolite horizons and the above observations may therefore be in error.

The lithology of the Zone remains remarkably constant throughout the Northern Cape, and is similar to that of the Transvaal. With the notable exception of riebeckite, it is also very similar to the taconite of the Lake Superior Region. In the Prieska area, where the Zone is nearly 3000 feet thick the lower half compares exactly with the remainder of the Cape, but the upper half is slightly different. The change is gradual and occurs at about the level of the Intermediate Crocidolite Horizon. The upper half, the so-called Weŝterberg beds (Cilliers and Genis, 1961), is characterised by the greater prevalence of riebeckite, both as pure mass-fibre beds and as scattered tufts or randomly orientated, slender needles. Chert bands are virtually absent and the rocks contain little stilpnomelane, usually as ferri-stilpnomelane, in contrast to the abundant ferro-stilpnomelane of the lower portion. No pure stilpnomelane bands are present.

At Danielskuil two, 3 to 5 feet thick, bands of intra-formational breccia (edgewise conglomerate) separated by 10 feet of strata occur some 500 feet above the Main Crocidolite Horizon. The breccias consist of slightly curved (dished), rounded flakes of banded chert set in a ferruginous matrix, which contains numerous fine chips and slivers of chert. The lowermost breccia appears to be the coarser of the two, containing chert flakes of all diameters up to 2 inches, in contrast to the upper which contains flakes of generally less than 1 inch diameter. The appearance of the lowermost breccia is illustrated in Plate XVIIIB. Similar intra-formational breccias have been reported at various horizons in the Kuruman area.

2. The Jasper or Mudstone Zone

Upwards in the succession, usually above the highest crocidolite horizons, the banded ironstone gradually changes to jasper by increase in thickness of chert layers and a marked decrease in the iron silicate and magnetite content of the rocks.

Over most of the Northern Cape the Zone is some 1000 - 1500 feet thick and consists of poorly bedded jaspers with a subconchoidal fracture and a tendency to spheroidal weathering. They are composed almost entirely of interlocking micro-crystalline quartz grains showing no preferred orientation. Fine dustings of hematite or limonite impart the characteristic red or yellow-brown colours to the rocks.

At Danielskuil a 10 feet thick bed of jasper with concretionary structure has the appearance of perfectly rounded boulders set in a jasper matrix. This bed has a characteristic appearance and its occurrence at a stratigraphic height of some 500 feet above the Lower Crocidolite Horizon makes it a useful marker horizon in this area. A number of similar concretionary beds were seen in the Kuruman area but their exact stratigraphic positions are not known.

In the Prieska area no jaspers are found, their place being taken by some 2500 feet of mudstone and shale. These rocks are soft and seldom form good surface exposures. Only a portion of the middle part of the succession was seen on Middelwater in the Prieska area, but the complete succession is given in a paper by Cilliers and Genis (1961).

Immediately above the Westerberg Crocidolite Horizon lies a succession of some 500 feet of finely banded grey, green and blue shales with occasional bands of mass-fibre riebeckite up to 6 inches thick. Chert bands and magnetite layers, so characteristic of the

Banded Ironstone Zone, are absent, while chlorite makes its first appearance in the succession, gradually increasing in amount upwards. The shale consists of alternating bands of micro-crystalline carbonate, and intimate mixtures of finely divided quartz, minnesotaite, riebeckite and chlorite.

The shale gradually loses its fine banding and grades upwards into a compact, cryptocrystalline, green mudstone, containing abundant chlorite and scattered crystals of magnetite. The mudstone forms a layer some 400 feet thick. Minute clastic grains of quartz and felspar can be recognised in the upper portions of the mudstone.

The mudstone is followed by a 20 feet thick, banded chert layer which contains sporadic developments of crocidolite. This chert layer, underlain by mudstone containing clastic quartz and felspar grains, outcrops in the northwestern portion of Middelwater on the eastern side of the fault shown in Plate I. A two feet thick band in this layer has the appearance of a small pebble conglomerate or coarse grit. Microscopic examination reveals rounded oval grains of either clear chert or carbonate-rich chert set in a brownish cherty matrix. This band may represent an intra-formational conglomerate, a rock type which is conspicuously absent from the Banded Ironstone Zone in the Prieska area.

The banded chert layer is followed by 300 feet of shale succeeded by more than 1300 feet of green mudstone which, like that below the chert layer, contains progressively more clastic grains as one moves upwards in the succession. The uppermost 200 feet of the mudstone contains layers of more ferruginous material with occasional chert bands.

The similarities in mineralogy and lithology of the rocks in the Mudstone Zone at Prieska to that of the chloritic shales of the

Jeppestown and Government Series of the Lower Witwatersrand System are remarkable. The latter Series even contains banded ironstones which, except for the absence of riebeckite, are identical to that occurring in the Banded Ironstone Zone.

3. The Glacial Zone

The jaspers are conformably overlain by a 50 to 100 feet thick zone containing exclusively detrital materials. The zone starts with quartzite which contains gritty to pebbly phases. The quartzite is sometimes completely or partially replaced by mudstone, interbedded with ferruginous material. The succeeding horizon is the tillite proper which forms a bed varying between 10 and 50 feet in thickness. It contains numerous striated pebbles, especially near the base. The pebbles are generally less than 2 inches in diameter and have a tendency to flatness, resulting in rounded to sub-rounded, bun-shapes. They consist mainly of grey or black chert, brown jasper and less commonly limestone, white quartz, grit or quartzite.

The matrix of the tillite varies upwards from a coarse arenaceous phase containing ferruginous material and some carbonate to a bluish-black mudstone with a varying calcareous content. The pebbles, which are very numerous in the lower arenaceous phase, become progressively smaller and less numerous in the argillaceous phase.

In the Prieska area the lower portion of the Glacial Zone is composed of mudstone with lenticular calcareous bands up to 25 feet thick. The tillite proper is only ten feet thick and is separated from the overlying lavas by a mudstone band of similar thickness. Striated pebbles, so common to the north, are definitely rare in this area. The matrix of the tillite is argillaceous and encloses numerous angular chert and jasper fragments which seldom exceed one inch in length.

(c) The Banded Ironstone Zone in the Transvaal

The most striking differences between the Banded Ironstone Zones of the Cape and the Transvaal are the greater degree of dynamic metamorphism suffered by the rocks and the presence of grunerite in place of minnesotaite in the latter Province.

In the Malips Drift area the rocks were intensely overfolded, resulting in numerous repetitions of outcrops which give an erroneous impression of the thickness of the Zone. The folds are isoclinal and dip at approximately 30° to the south, indicating that the pressure came from this direction. The strata are intensely deformed and small-scale isoclinal overfolds, as illustrated in Plate XVIII, are numerous. Thickening of the incompetent layers in the crests and troughs of the folds can be seen near the hammer in the plate. The folding was to a large extent post-fibre formation, as shown by the numerous instances of steeply inclined, slip- or bent fibres in the asbestos seams. Much recrystallisation also took place, large porphyroblast of magnetite cutting the fibres which, in numerous instances, have also been partly recrystallised to needle riebeckite, as shown on Plate XIXA. In the barren strata recrystallisation under directed pressure caused the partial alignment of the minerals as shown on Plate XIXB.

With the notable exception of minnesotaite, the same minerals found in the Cape are generally present in the Transvaal. Carbon or graphite, both as disseminations and thin layers, appear to be more prevalent. Grunerite in the form of thin needles and prismatic crystals with fibrous ends takes the place of minnesotaite in the chert layers. Pure stilpnomelane layers were not seen, but ferro-stilpnomelane in coarsely granular patches (Plate XX) is frequently associated with grunerite, carbonates, carbon and minor riebeckite in certain chert layers, the so-called "cummingtonite-slate" of Hall (1930, p.162).

PLATE XVIII



SMALL SCALE ISOCLINAL OVERFOLDS IN
MIXED AMOSITE - CROCIDOLITE REEF

Leather Mine, Beatrice Claims, Malips
Drift, Tvl. Approx. 1/10th natural
size.

Amosite seams (white) and crocidolite
seams (pale blue-grey) in banded iron-
stone (purplish-blue) carrying blebs
of carbonate (round white spots).

PLATE XIX



A. PARTLY RECRYSTALLISED RIEBECKITE
IN CROCIDOLITE SEAM

Spec.G6T. Plane polarised light,
X 138 diameters.

Needle riebeckite (dark grey), mag-
netite (black) and quartz (white)
in crocidolite (light grey).

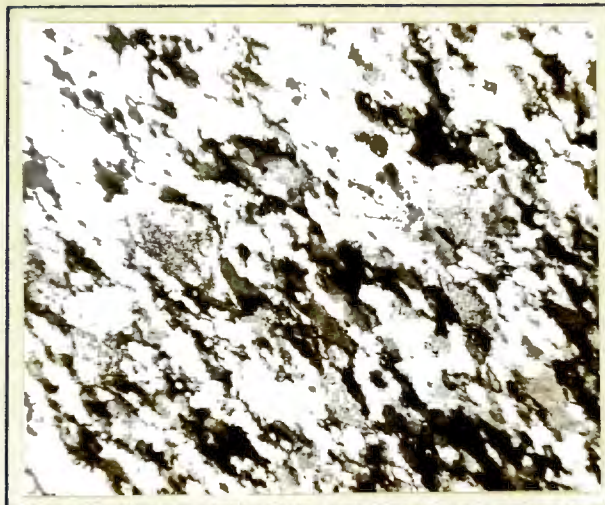

B. ORIENTATION OF RECRYSTALLISED
MINERALS IN BANDED IRONSTONE

Spec.G11T. Crossed nicols, X 138
diameters.

Recrystallised quartz (white to
dark grey) and drawn out granular
carbonate blebs (high relief).

PLATE XX

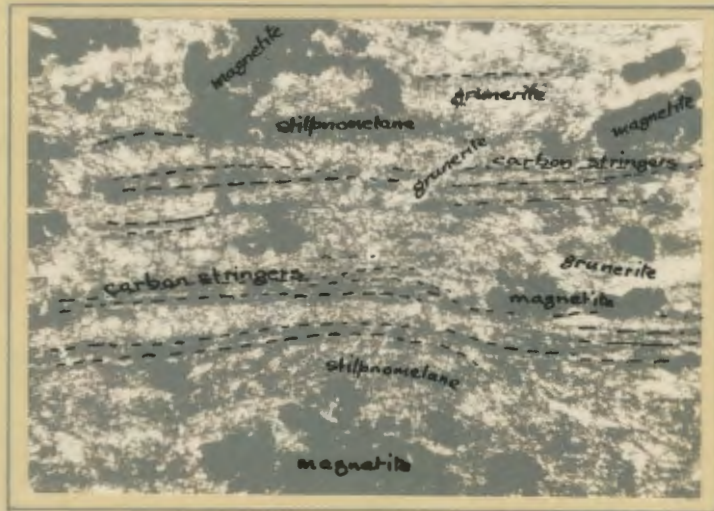

CUMMINGTONITE SLATE

Spec. G16T, Rabieskloof, Malips Drift,
Tvl. Plane polarised light, X 138
diameters.

(d) Chemistry of the Banded Ironstone Zone

Six specimens of various layers in the Cape Province and one specimen from the Transvaal were analysed by methods detailed in Appendix 1. The results are listed in Table No.8. It must be remembered that, since the rocks are finely layered and their mineralogical composition changes from layer to layer, the chemical composition of any one specimen will be dependant to a large extent on the sampling. The analyses listed in Table No.8 should therefore be regarded only as an indication of the chemical composition of the various types of layers.

The rocks chosen for analysis were:-

G90P: Faintly bedded, dark olive green stilpnomelane from 6 inches above bottom contact of a 3 feet thick layer in No.1 Drive, Glen Allen Mine, Prieska. It consists of scattered minute quartz slivers, some sub-rounded, set in a micro-crystalline matrix of ferro-stilpnomelane and interbedded with micro-crystalline ferro-stilpnomelane carrying carbon fragments. There is a slight suggestion of graded bedding in the quartz fragments.

G89P: Massive, nearly black, stilpnomelane from 6 inches below upper contact of the layer mentioned above. It contains rare blebs of carbonate and scattered, minute magnetite crystals.

G21P: Micro-banded, granular carbonate and ferro-stilpnomelane with rare magnetite crystals from immediate footwall of a stilpnomelane layer in the Middle Reef, No.4 level, Dikberg Mine, Prieska.

G7P: Banded chert-rhombic carbonate layer with rare scattered magnetite crystals and large pyrite porphyroblasts. Minor

fibrous riebeckite occurs in a micro-layer where they crystallised preferentially on the carbonate (Plate IIIA, p.16).

G7M: Banded magnetite-chert with scattered rhombic carbonate and partly silicified crocidolite seams of less than 1 mm. thickness. The chert layers contain no minnesotaite. Drill-core from near Heuningvlei, Vryburg.

G26P: Banded magnetite-chert rock. Magnetite layers up to 1 cm. thick and contain quartz, carbonate and riebeckite as accessories. Chert layers 3 to 5 mm. thick containing abundant minnesotaite.

G16T: Transvaal specimen from Rabieskloof, Malips Drift. Banded "cummingtonite-slate" consisting of alternating layers of chert with grunerite crystals, rare riebeckite shreds and granular patches of ferro-stilpnomelane, partly oxidised to ferri-stilpnomelane in places, and very thin stringers of carbon or graphite. Crystalline patches of magnetite with interstitial quartz are frequent (Plate XX, p.66).

The high potash content of the stilpnomelanes is surprising. Since Al_2O_3 is thought to be virtually confined to stilpnomelane, specimen G89P contains only half the amount of stilpnomelane present in G90P despite the microscopic appearance. The $Al_2O_3 : K_2O$ ratios in the two analyses are 1.34 and 1.15 respectively, while those in the banded chert-magnetite specimens (G7M and G26P) are of the order of 0.45. The relatively high TiO_2 content of these specimens in contrast to the others indicates that the stilpnomelane contains essential titanium in addition to potassium and aluminium, while the high $Fe^{++} : Fe^{+++}$ ratios show that it is of the ferro-stilpnomelane variety. It probably contains a minor amount of magnesium as well. The presence of stilpnomelane in specimens G21P and G16T is indicated by their $Al_2O_3 : K_2O$ ratios.

TABLE NO.8

Specimen number	G90P	G89P	G21P	G7P	G7M	G26P	G16T
SiO ₂	57.1	47.5	31.5	48.1	55.1	22.9	36.8
Al ₂ O ₃	11.6	6.3	3.12	0.49	0.10	0.10	2.61
Fe ₂ O ₃	3.2	10.0	8.2	3.8	13.3	44.1	17.2
FeO	11.86	23.17	28.37	11.57	13.79	26.15	27.05
MnO	0.05	0.09	0.96	0.34	0.18	0.02	0.74
MgO	1.86	4.24	5.15	4.58	2.50	2.01	2.56
CaO	0.7	0.2	3.7	11.7	3.1	0.6	0.5
Na ₂ O	0.41	0.46	0.28	0.36	0.33	0.07	0.19
K ₂ O	10.10	4.70	1.20	0.16	0.25	0.21	2.45
H ₂ O ⁺	3.00	4.82	3.42	0.43	0.21	0.32	1.37
TiO ₂	0.49	0.23	0.05	0.05	0.12	0.05	0.22
CO ₂	0.26	1.66	17.79	18.08	7.80	3.67	5.91
P ₂ O ₅	0.03	<.01	0.16	Nil	<.01	Nil	Nil
Cr ₂ O ₃	0.03	0.02	0.05	0.02	0.05	0.08	0.05
C	-	-	-	-	-	-	2.26
TOTALS	100.7	103.4	104.0	99.7	96.8	100.3	99.9
Al ₂ O ₃ /K ₂ O	1.15	1.34	2.60	3.06	0.40	0.48	1.07
Fe ⁺⁺ /Fe ⁺⁺⁺	4.12	2.57	3.84	3.38	1.15	0.66	1.75

- Oxide not determined.

All analyses carried out on material dried at 110° C.

In specimens G21P and G7P the approximate composition of the carbonate was calculated from the CaO, MnO and MgO contents. In the case of G21P an estimated amount of 0.48% MgO, thought to be present in stilpnomelane, was first deducted. The remaining CO₂ after all the above oxides were satisfied was apportioned to FeO. The following results, which are in reasonable agreement with those deduced from the optical data on p.61, were obtained:-

G21P: granular carbonate associated with stilpnomelane

58.9% FeCO₃; 23.2% MgCO₃; 14.1% CaCO₃

G7P: rhombic carbonate associated with chert.

51.9% CaMg(CO₃)₂; 42.2% CaFe(CO₃)₂; 2.7% CaMn(CO₃)₂
together with 3.2% FeCO₃.

The trace element distribution in the analysed specimens is given in Table No.9. The amounts are given in parts per million of the element. Those looked for but not detected were:-

B, V, Sc, Nd, Ce, La, Nb, Pb, W, Ge, Sn, Ga, Cu, Be,
Ni, Zr, Co, Au, Pt and Mo.

TABLE NO.9

Rock-type	Spec. No.	Li	Rb	Cs	Ba	Sr	Cr	Mn	Rb/Cs
Stilpnomelane	G90P	4.8	215	19	920	26	140	195	11.32
Stilpnomelane	G89P	4.1	245	64	520	26	260	320	3.83
Stilp.-Carb.	G21P	0.3	46	20	33	90	365	2600	2.30
Chert-Carb.	G7P	0.5	12	1.7	250	170	180	1450	7.06
Cumingtonite-Slate	G16T	3.1	220	100	120	29	370	2100	2.20
Chert-Magt.	G7M	0.6	21	n.d.	n.d.	37	340	940	> 21
Chert-Magt.	G26P	-	-	-	n.d.	37	610	210	-

n.d. = not detected

- = not determined

The apparent absence of vanadium seems strange in view of the fact that chromium, manganese, iron and titanium are present in varying amounts. A semi-quantitative, spectrographic survey showed that vanadium, chromium, titanium and aluminium are present in major amounts in the shale "passage-beds" between the Dolomite Series and the Banded Ironstone Zone at Prieska, in a stilpnomelane layer associated with the Lower Crocidolite Horizon at Danielskuil, in the mudstones below the chert layer of the Mudstone Zone at Prieska, in the basic intrusive sills of the Lower Griquatown Stage, in the lavas of both the Middle Griquatown Stage and the Ventersdorp System, and in the shales of the Timeball Hill Stage of the Pretoria Series at Pretoria.

Since vanadium is likely to occur in the magnetite lattice, the magnetite from a number of different layers was separated and spectrographically analysed with the following results expressed in parts per million of the element.

	Mn	Cr	Ti	V	
HV16	1120	n.d.	n.d.	n.d.	Metamorphic magnetite in chert (refer p.75).
G26P	n.d.	n.d.	n.d.	n.d.	Magnetite layers in chert
G29P	n.d.	n.d.	n.d.	n.d.	Magnetite screen on crocidolite
G23T	n.d.	n.d.	320	n.d.	Magnetite screen on crocidolite
G4P	825	54	775	61	Magnetite in stilpnomelane
G18T	810	78	1330	93	Magnetite in stilpnomelane
G16T	1890	60	n.d.	3400	Magnetite in cummingtonite slate

(n.d. = not detected)

The magnetite associated with the stilpnomelane bearing bands therefore appears to have the same trace element distribution as the shales and lavas.

The alkali metals, lithium, rubidium and caesium, appear to be confined to stilpnomelane, which also contains barium, but little strontium. The ferro-dolomite of specimen G7P contains significant amounts of both barium and strontium in contrast to the siderite of specimen G21P which has significant strontium but little barium. The relatively high manganese content of the carbonate-rich specimens shown in Table No.8 is confirmed by the spectrographic analyses in Table No.9. The distribution of chromium appears to be random, although the analyses on p.70 indicate that chromiferous magnetite is confined to the stilpnomelane layers.

The Rb : Cs ratios in Table No.9 show significant relative enrichment of caesium in some of the stilpnomelane-rich layers, but not in others. The specimens, G89P, G21P and G16T, showing this caesium enrichment, all contain dustings or rod-like fragments of carbon. In order to check this association, the Rb : Cs ratio of specimen G6P, which contains rod-like fragments of carbon, as shown in Plate XVI, p.61, was determined and found to be 1.96. Similar low ratios of Rb : Cs were found in Trilobite fossils by McKerrow, et al (1956) during spectrographic analysis of various insects and fossils. The ratio for the average sedimentary rock is of the order of 15 (Channey, 1952). The conclusion that the association of carbon with caesium is due to a soft-bodied fore-runner of the Cambrian Trilobites is very tempting. That the caesium is not an essential part of the stilpnomelane is brought out by the Rb : Cs ratios of 11.32 for G90P which contains twice as much stilpnomelane as G89P and 10.42 for a green biotite, thought to be metamorphic equivalent of stilpnomelane, in specimen G68P.

(e) Structure and folding

The Lower Griquatown Stage has been folded into a series of broad north-south anticlines and synclines in which, for the most part,

the full section has been preserved under a capping of Middle Griquatown Lavas. The largest of these, the Ongeluk-Witwater Syncline, stretches northwards from Griquatown nearly to Kuruman. Its attendant anticline, the Maremane Anticline, passes through Postmasburg. In the Prieska area the Abramsdam, Juanana and Leelykstad Synclines still have this northerly trend, but southwards the structures swing to the southeast along the Doornberge. These regional structures are indicated on the attached Plate I.

Throughout the Northern Cape, the lower portion of the Banded Ironstone Zone is remarkably wrinkled and contorted, even in areas where large scale regional folding is absent. The folding is of small amplitude and appears to be the result of flowage and slumping of the beds soon after deposition and before lithification. The so-called "rolls", the monoclinical structures of small amplitude which are so numerous in the lower strata, may have been initiated during this period. These rolls were further accentuated and even overthrust by later periods of folding. As a result of the pre-lithification folding, the more plastic layers within the rocks were thickened along the crests and troughs of folds and thinned out along their flanks.

Another type of wrinkling, somewhat akin to the disharmonic folding sometimes displayed by gypsum beds where it results from the expansion or contraction of one layer relative to the others, is also frequently encountered. This type of folding is illustrated in Plate XXI, where the light coloured chert and darker, iron silicate layers appear to have shrunk relative to the thin, black, iron oxide layers during lithification.

After deposition of the overlying Matsap formation both this Formation and the underlying Transvaal System were subjected to intense pressure directed from the west. Along the western edge of the original depositional basins the rocks were intensely folded and, in areas

PLATE XXI



DISHARMONIC FOLDING IN BANDED IRONSTONE

Outcrop on Klipfontein, Prieska. Approx.
1/5th natural size.

Light coloured chert bands and thicker grey
silicate bands are thought to have contracted
relative to the dark grey thin magnetite
layers.

of maximum pressure, such as at Postmasburg, numerous low angle thrust faults developed. The lower wrinkled portions of the banded ironstone were extensively brecciated where they were thrust over the Dolomite Series. The brecciation was further accentuated in certain cases by later subsidence into solution cavities in the dolomite. Extensive leaching and later cementation of the fragments with ferruginous material gave rise to the distinctive "Blinkklip Breccia", the so-called Cataclastic Rocks shown in Plate I.

Low angle thrust faulting also affected the eastern edge of the Dimoten Syncline to a certain extent, as well as the lower portions of the banded ironstone in the Prieska area (as at Orange View and Kransfontein). More striking in the Prieska area, however, are the near vertical, normal faults, with downthrows to the east, which run sub-parallel with the large Doornberg fault. One of these faults, with a downthrow of approximately 3000 feet to the east, traverses the farm Middelwater in a northwesterly direction. They cut through the folded Lower Griquatown Stage and are therefore younger than the period of thrusting.

Basic dykes have since intruded along many of these younger faults.

(f) Igneous activity

A number of basic igneous sills, the hypabyssal equivalents of the Middle Griquatown Lavas, occur in the Lower Griquatown Stage. The sills vary from hundreds to a few feet in thickness, but in any one area they are reasonably constant in thickness and occupy the same stratigraphic horizon over numbers of miles. The 300 foot thick sill immediately above the Intermediate Crocidolite Horizon on the farm Koegas in the Prieska District still occupies this horizon and has the same thickness at Orange View, a distance of some 10 miles

to the S.E. of Koegas. The sills were folded together with the banded ironstone during the post-Matsap folding.

Numerous basic dykes, some of Karroo dolerite affinity, cut through the rocks of the Lower Griquatown Stage and, since they frequently occupy the younger, normal faults and also cut through the folding, they are post-Matsap in age.

On the western limit of Dikberg Mine a basic dyke, which has suffered much shearing, occurs along a vertical fault. It would appear that the faulting took place in several pulses, the dyke being intruded along with or soon after the initial pulse.

The dykes tend to weather more rapidly than the banded ironstones and thus produce straight sided channels through the ironstone ridges, as shown in Plate VI, p.22. From the air, the course of the dykes can be easily traced by the long, straight sand or rubble filled declivities formed over them. These declivities are clearly shown in Plate XXII. Frequently the course of a dyke is outlined by vegetation, trees and shrubs growing preferentially along the contacts, thus producing a recognisable avenue.

(g) Metamorphism

The recognisable effects of large scale, regional metamorphism appear to be lacking in the Lower Griquatown Stage. Although the rocks had been subjected to considerable horizontal pressure in some areas, relief of pressure took place mainly by folding and lateral movement of material, the stresses set up being insufficient to generate new mineral assemblages.

Thermal metamorphism of such a low grade that it could be classed as diagenesis did affect the rocks of the Lower Griquatown Stage on a regional scale. This "regional" thermal metamorphism

PLATE XXII



AERIAL VIEW OF BANDED IRONSTONE HILLS
SHOWING DECLIVITIES FORMED OVER DYKES

Outcrops of banded ironstones cut by dykes in
a northeasterly direction. Heuningvlei, Vry-
burg District. Vertical aerial photograph,
approximate scale = 1 : 40,000.

generated such minerals as crocidolite, riebeckite and possibly stilpnomelane and minnesotaite from clay-like precursors. In the Transvaal, where the grade of metamorphism was slightly higher, grunerite was formed in place of minnesotaite. The numerous instances of crocidolite and riebeckite being fractured, sheared and sometimes recrystallised by the post-Matsap folding indicate that the thermal metamorphism was complete before the severe post-Matsap deformation took place. Most of the thermal energy was, however, expended on a slight enlargement of the mineral grain sizes by recrystallisation, more particularly the quartz in the chert layers. Thus in the Transvaal the quartz grains of the Main Crocidolite Horizon are normally of the order of 0.10 mm. in diameter in contrast to 0.05 mm. in the Lower Crocidolite Horizon of the Cape. The 0.02 to 0.03 mm. size of quartz grains in the one specimen of banded ironstone from the Nullagine Series in Western Australia available to the writer suggests that these rocks underwent the same degree of thermal metamorphism as those of the Cape.

The intrusion of basic sills and dykes caused very little metamorphism of the adjoining rocks apart from a slight enlargement of mineral grain sizes by recrystallisation. Since the temperature gradient adjacent to an igneous intrusion is very steep, the recrystallisation took place over a very short distance on either side of the intrusion. An interesting metamorphic effect was noticed in banded, chert-magnetite layers immediately above a basic sill intersected in a borehole on Heuningvlei. The magnetite grains, which become progressively larger in grain size as the sill is approached, all appear perfectly rounded (Plate XXIII). Closer examination revealed that the magnetite had suffered chemical attack along the octahedral planes, resulting in a rounded section, as illustrated in Fig.8. The upper portion of the sill is micro-amygdaloidal, the amygdales

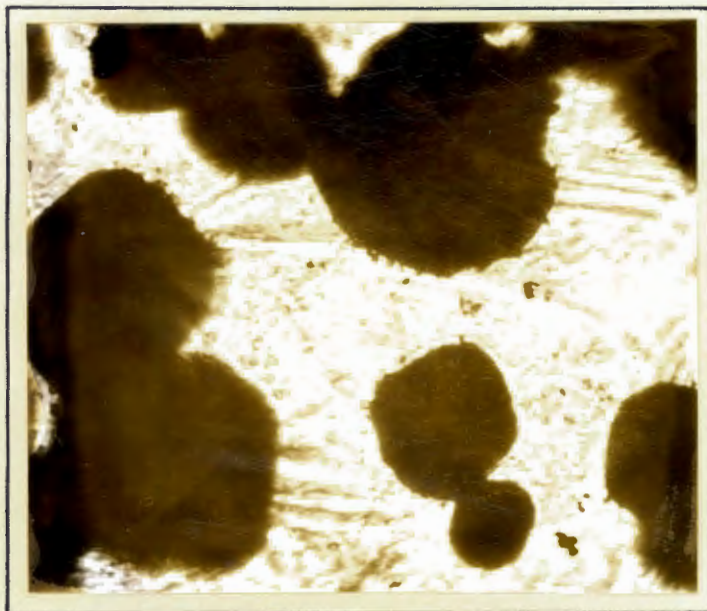

CHEMICALLY ROUNDED MAGNETITE CRYSTALS
SET IN FIBROUS QUARTZ

Spec.HV16/354A. Plane polarised light,
X 2923 diameters

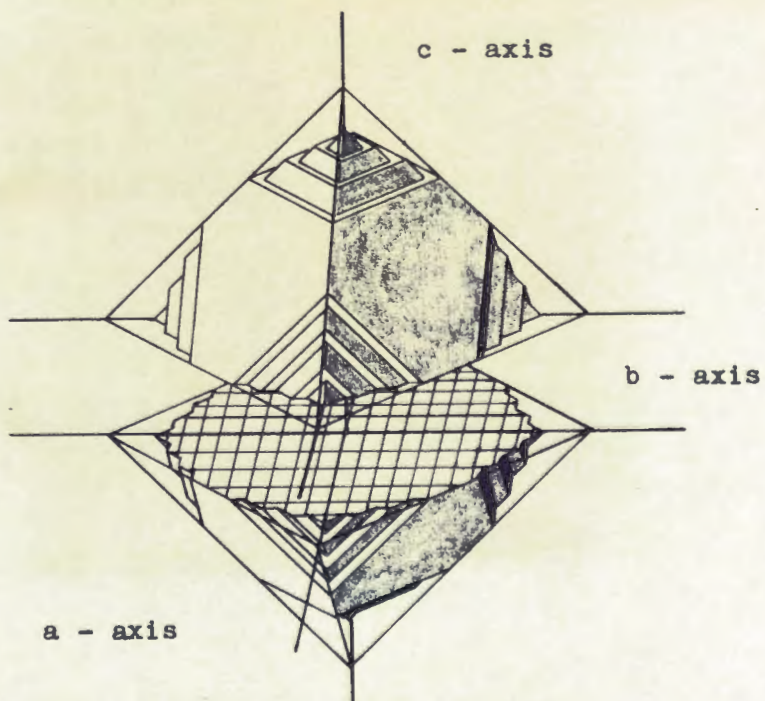

Fig.8. Diagram showing how a rounded section is derived
by progressive removal of octahedral planes.

being less than 1 mm. in diameter and chlorite filled. It is thought that the intrusion of the sill, possibly into damp, relatively unconsolidated sediments, as indicated by the amygdaloidal contact phase, caused the recrystallisation of the magnetite. Late deuteric vapours, probably sulphur-rich, attacked the magnetite along the octahedral planes; the pyrite thus formed crystallising in irregular, microcrystalline masses in the chert layers.

On Middelwater and Orange View in the Prieska district a thin layer of acmite-bearing ironstone, exactly similar to that described by du Toit (1945, p.175), occurs approximately 100 - 200 feet below the Intermediate Crocidolite Horizon. The layer appears to occupy a stratigraphic horizon. The acmite is found in stellate clusters of prismatic crystals, usually aligned sub-parallel to the bedding planes. Microscopic examination reveals that the bedding planes, as picked out by layers of magnetite, continue right through the acmite crystals without any apparent disturbance. The crystals in specimen G69P from Middelwater are set in a recrystallised granular quartz matrix, the diameter of the quartz grains being of the order of 0.11 to 0.13 mm. The matrix also contains numerous riebeckite needles, flakes of emerald green biotite with numerous magnetite inclusions, and hematite, apparently pseudomorphous after magnetite. The acmite from this specimen contains 9.3% Na_2O . It has the following optical properties:-

Good prismatic cleavage

α to $c = 6^\circ$

$\alpha = 1.770$

$\gamma = 1.810$

Faintly pleochroic with

$X > Y = Z$

$X =$ pale greenish brown

$Y = Z =$ pale pinkish brown

The optical properties are in close agreement with those given by du Toit (1945, p.175) and also with those of the artificially prepared acmite described in Appendix No.2.

On Middelwater a 5 to 6 mm. layer, composed almost entirely of the green biotite which occurs as an accessory to the acmite, was found immediately below the acmite-bearing layer (Specimen G68P). The biotite is riddled with minute magnetite euhedra, which appear to be an exsolution product. It has the following optical properties:-

BXa approximately perpendicular to the perfect basal cleavage.

$2V = 7^{\circ}$; optically negative.

$\alpha = 1.616$

Strongly pleochroic with $X < Y = Z$

$\beta = 1.660$

X = bright golden yellow

$\gamma = 1.662$

Y = Z = deep emerald green.

No explanation could be found for the occurrence, within the relatively unmetamorphosed rocks of the Banded Ironstone Zone, of a layer which had suffered metamorphism comparable to that in the Transvaal. The only igneous sill of any size, the 300 feet thick basic sill above the Intermediate Crocidolite Horizon, lies some 300 to 400 feet above the layer. The acmite is thought to derive from riebeckite under oxidising conditions while the green biotite probably comes from stilpnomelane.

VI. THE GENESIS OF THE PRECAMBRIAN BANDED IRONSTONES

The genesis of the Precambrian banded ironstones can be discussed under two related headings. These are:- (a) Their distribution in time, and (b) Their mode of formation.

(a) Distribution in time

A study of the distribution of the banded ironstones in time shows that none are known to be younger than 1000 million years. This restriction of the banded ironstones to the Precambrian has been ascribed to special conditions which prevailed during their deposition, conditions which have not been repeated to any noteworthy extent afterwards. MacGregor (1927, 1951) suggested that optimum conditions for the dissolution, transport and precipitation of iron and silica existed during the early Precambrian because the atmosphere consisted mainly of carbon dioxide and nitrogen, with little or no free oxygen. He argued that the absence of green plants which could use carbon dioxide in photosynthesis, and the fact that up to then no atmospheric carbon had been immobilised as organic remains in sediments, would lead to a rapid accumulation in the atmosphere of carbon dioxide emanations from volcanoes. Liebenberg (1955) supports this view in order to account for the stability of detrital uraninites during the deposition of the Witwatersrand bankets. Tyler and Twenhofel (1952) postulate a reducing Precambrian atmosphere in order to explain the extensive transport of iron as stable ferrous solutions during deposition of the Huronian Iron Formation in North America.

The nature of the earth's Precambrian atmosphere

The nature of the earth's Precambrian atmosphere has long been the subject of considerable speculation. Hypotheses on the origin of the earth's atmosphere fall into two categories:-

- (i) That the atmosphere consists of the residual components of a dense, primitive atmosphere.
- (ii) That it has accumulated during geological time by the degassing of the earth.

(i) A residual atmosphere

Several cogent arguments have been advanced for a primitive atmosphere composed mainly of ammonia, methane and hydrogen, a hypothesis strongly supported by Urey (1951, 1952). The Oparin-Horowitz theory of the origin of life requires such a strongly reducing atmosphere (Wald, 1954, p.49). This theory postulates the formation of complex organic compounds in the atmosphere by photochemical processes. The compounds remained stable in the absence of oxygen and collected in the sea water, resulting in the forming of a type of "organic broth" with the passage of time. In this ideal growing medium, complex polymerisations of organic molecules resulted in the formation of primitive, self-duplicating, macro-molecules (amino-acids and proteins) which evolved into more specialised organisms as they consumed the "organic broth". It is noteworthy that Miller (1953) recently succeeded in synthesising carboxylic and amino-acids by passing repeated electric discharges through a mixture of water vapour, methane and hydrogen.

also 1959, Handbuch
d. Physik

The stability of methane and ammonia in an atmosphere depends on the presence of free hydrogen. Hydrogen has an escape rate from the earth's gravitational field of such magnitude that significant amounts

of methane and ammonia could not have persisted in the primitive atmosphere for longer than 10^5 to 10^8 years (Rubey, 1955, p.645). Consideration of the Equilibrium constants of the various gas reactions, which could take place in such an atmosphere, shows that a carbon dioxide-nitrogen primitive atmosphere is far more likely (Rubey, loc.cit., p.637-641). A high, partial pressure of carbon dioxide in the atmosphere is, however, contra-indicated by the lack of recognisable chemical effects in ancient sediments. A very high partial pressure of carbon dioxide would have resulted in the rapid leaching of exposed igneous rocks and the deposition of voluminous quantities of limestones and dolomites.

(ii) A slowly accumulating atmosphere

Stony meteorites are considered to be remnants of a broken-up planet with a size comparable at least to the moon, and they provide us with samples of the probable constitution of the mantle. Their occluded gases should give some indication as the constitution of a primitive atmosphere formed by degassing of the mantle. The most abundant gases in stony meteorites are carbon dioxide, carbon monoxide and nitrogen. Similarly, the most abundant gases given off by present day volcanoes are water vapour, carbon dioxide and the oxides of sulphur.

A gradual accumulation of gases occluded in the earth's mantle would have resulted in a primitive atmosphere composed mainly of carbon monoxide, carbon dioxide and nitrogen. The partial pressure of the slowly accumulating carbon dioxide would have been kept at a low figure, probably not much different from its present day level, by the presence of large bodies of water.

The importance of the sea in controlling the partial pressure of carbon dioxide in the atmosphere should be emphasised. Sea water contains $20 \text{ gm CO}_2/\text{cm}^2$ as against $0.4 \text{ gm CO}_2/\text{cm}^2$ in the atmosphere

(Mason, 1958, p.211). These two quantities are inter-related and directly proportional to the partial pressure of the carbon dioxide. To double its partial pressure would require the addition of an amount of carbon dioxide far in excess of 0.4 gm/cm^2 in order to overcome its increased solubility in the water. Similarly, a decrease in partial pressure would reduce the solubility considerably with the resultant liberation of carbon dioxide. The presence of large bodies of water during the Precambrian would therefore have exerted a strong stabilising influence on the partial pressure of carbon dioxide in the atmosphere.

The evolution of the oceans

The evolution of the earth's oceans is also controversial. Some writers contend that there were no deep seas until the end of the Paleozoic. Twenhofel (1932) proposed the gradual growth of the oceans since Devonian times. Keunen (1950) and Conway (1943), on the other hand, maintain that the volume of the oceans have remained substantially the same since early Precambrian times. If a gradual accumulation of occluded gases, which would contain vast quantities of water vapour, is assumed for the origin of both the atmosphere and the hydrosphere, then the bodies of water already condensed during Precambrian times would have kept the slowly accumulating carbon dioxide at a low partial pressure. This would have resulted in the observed minor, but steady deposition of limestones and dolomites during the Precambrian as compared to post-Cambrian times.

A gradual accumulation of the oceans throughout geological time does not seem likely when considering geological evidence of the permanence of the continents and ocean basins. It should, however, be borne in mind that this evidence is based to a large extent on fossils and little is really known of the paeleo-geographical conditions during the Precambrian. If the volume of sea water increased steadily, but the areal distribution of the continents and the ocean basins remained

relatively constant, then there must have been a considerable deepening of the ocean basins during geological time. The evidence of ocean floor subsidence provided by guyots in the Pacific Ocean could be significant (Hess, 1946). These flat-topped, seamounts lie at depths varying between 1,000 and more than 3,000 meters below sea level. The fact that no guyots with their tops at less than 1,000 meters below sea level have been found is explained by contemporaneous coralline growth with subsidence. Since coralline growth only came into full swing during the Cambrian, some 500 million years ago, it follows that the floor of the Pacific has subsided at a rate of some 2 meters per million years since Cambrian times. Similar evidence of ocean floor subsidence is provided by the presumably wave-cut terraces on the mid-Atlantic Ridge. Numerous other factors, such as the growth of the continents by lateral accretion, isostatic compensation and the rate of deep sea sedimentation should be taken into account before a figure for the rate of ocean floor subsidence could be arrived at. Rubey (1951) summarised all the ^{the} available data on the growth of the oceans and came to the conclusion that they accumulated gradually but with a reasonably constant composition, similar to the present day composition, throughout geological time.

how good is the evidence for this?

The oxygen content of the Precambrian atmosphere

All the hypotheses of the probable constitution of the primitive atmosphere have in common a postulated deficiency or total lack of free oxygen. Three processes for the later addition of oxygen have been suggested (Mason, 1958, p.205). These are:-

- (i) By thermal dissociation of water vapour when the earth's surface temperature was $1,500^{\circ}\text{C}$. or higher.
- (ii) By the decomposition of carbon dioxide and water during photosynthesis.
- (iii) By the photochemical dissociation of water vapour in the upper atmosphere and the subsequent escape of the free hydrogen.

The thermal dissociation of water vapour depends on a number of variables and it is doubtful whether the high temperatures required were ever attained on the earth's surface. Urey (1951, p.220) estimates that the surface temperature of the earth never rose above some 900°C. during its entire history of accretion and solidification. Kuiper (1952), on the other hand, postulates that the earth passed through a molten stage some 100,000 years after its original accretion. Any oxygen formed by thermal dissociation during this stage would, however, have been used in oxidising volcanic CO to CO₂.

what evidence do you use?

Photosynthesis is a characteristic process of the higher orders of plant life, and the present day level of oxygen in the atmosphere is kept constant almost entirely by this process. Since green plants consume oxygen during the hours of darkness, it seems unlikely that they could have developed in the absence of oxygen. Until such time as primitive plants developed, some other source of oxygen must have been operative. The photochemical dissociation of water vapour in the upper atmosphere may have fulfilled this requirement.

Kuiper (1952, pp.310-314) estimated that the photochemical dissociation of water vapour by short-wave solar radiation operates at a rate which, if continued throughout geological time, would have produced five times the amount of oxygen present in the atmosphere today. This, however, is only a fraction of the amount of oxygen removed from the atmosphere by the oxidation of material now incorporated in sediments. It is possible that, prior to the formation of the ozone layer in the upper atmosphere; photochemical dissociation proceeded at a faster rate due to the deeper penetration of short-wave radiation into the atmosphere.

Geological evidence as to the presence of free oxygen in the primitive atmosphere is inconclusive. The Fe⁺⁺/Fe⁺⁺⁺ ratios in certain ancient sediments do not differ markedly from those in post-Cambrian

rocks. The occurrence of interbedded gypsum and anhydrite in Precambrian limestones also indicates that sulphur was present in its higher states of oxidation. On the other hand, Rankama (1955) found the high ratios of Fe^{++}/Fe^{+++} in certain Finnish conglomerate-schists, approaching 2000 million years in age, indicative of a reducing atmosphere. He relates the finely disseminated, free carbon found in many ancient sedimentary rocks to the lack of oxygen which would normally have oxidised decomposing organic material to carbon dioxide.

Although free oxygen was probably present in the early Precambrian atmosphere, its partial pressure would have been kept very low by the oxidation of large volumes of volcanic CO and sedimentary material. Once plants capable of photosynthesis evolved, the amount of oxygen in the atmosphere would have slowly increased to its present level.

The start of photosynthesis

References to carbonaceous material of possible organic origin in the Precambrian rocks are legion, and it is generally accepted today that living organisms originated very early in the Precambrian. McGregor (1941) recorded the occurrence of algal structures, together with graphite, in limestones, situated well down in the greenstones of the Bulawayan System, which is considered to be more than 2700 million years old. Its South African counterpart, the Swaziland System, also includes graphitic shales. Numerous occurrences of carbon or graphite have been reported in the Transvaal System. The stromatolitic algal growths in the Dolomite Series of this System have already been mentioned. These growths were caused by simple algae, possibly belonging to the Cyanophyceae family, the so-called Blue-Green Algae. The Cyanophyceae, the present-day green scum on ponds, are filamentous structures, usually organised into colonies, and they derive their carbon from the atmosphere

by photosynthesis. It follows that photosynthesis may have been an established process during the deposition of the Transvaal System, approximately 2000 million years ago. Further evidence of the early establishment of photosynthesis is the occurrence of Precambrian "coal" in rocks of Huronian age in North America (Barghoorn, 1957, p.82). Conclusive, fossil evidence of the existence of Cyanophyceae at the time of the deposition of the Lake Superior banded ironstones was found in the dense, unrecrystallised, non-ferruginous, basal cherts of the Gunflint Formation (approximately 1,500 million years old). The algal structures are remarkably well preserved. A concentration of 2.0 micromoles of amino-acids per gram was chromatographically proved in these cherts by a meticulous method of analysis which prevented all chances of surface contamination (Barghoorn, loc.cit. p.82-83). Gruner, as long ago as 1922, noted the presence of certain microstructures which he interpreted as algal and bacterial remains in the banded iron formations of the Biwabik Formation. The similar structures found in the Indian banded ironstones by Spencer and Percival (1952) may well be of biologic origin. No comparable structures were found in the South African banded ironstones.

Barton (1948) succeeded in identifying fossil bacteria in Oligocene rocks by electron microphotography, while Cayeaux found similar fossils in both the French oolitic iron ores and the Huronian banded iron ores of Minnesota by means of infra-red photography. Future applications of these techniques, together with analysis for amino-acids, will no doubt prove conclusively the existence of bacteria and algae during the deposition of the South African banded ironstones.

Thode, McNamara and Fleming (1953), in their investigation of the distribution of stable sulphur isotopes between sulphates and sulphides, came to the conclusion that the fractionation of the isotopes did not start until approximately 700 - 800 million years ago. Al-

though biogenic matter and living organisms certainly existed at the time, such autotrophic organisms as derive their free energy from the oxidation and reduction of sulphur compounds had not yet made their appearance. They believed that this date possibly marks the onset of large-scale photosynthesis. The writer, however, feels that "plants" capable of photosynthesis developed very early in the geological history of the earth, certainly prior to the deposition of the Bulawayan System some 2700 million years ago. The abundance of pyrite in the Witwatersrand and Transvaal Systems certainly makes the existence of sulphur reducing organisms during the deposition of these Systems likely. Recently Ault (1959) showed that it must be concluded that there is no simple correlation between geologic age and the extent of S^{32}/S^{34} fractionation and that bacterial reduction of sulphates has been an important factor for at least the past 2000 million years.

The origin of photosynthesising plants

It is thought that during the early part of the Precambrian, the extremely tenuous atmosphere lacked an ozone layer. High energy ultra-violet radiation must have penetrated right down to the surface of the earth. On earth strongly reducing conditions would have existed locally due to the exposure of minerals in highly reduced states. Under these conditions the Oparin - Horowitz process of organic synthesis may have operated in a carbon dioxide - nitrogen atmosphere. The first organisms formed derived their energy from fermentative processes. Certain fortuitous polymerisations may have resulted in the formation of metal porphyrins (e.g. chlorophyl, haemoglobin, etc.) in the sea. Once these catalysts were present, primitive organisms could reduce the dissolved carbon dioxide and derive their free energy by the far more efficient process of oxidation of carbohydrates. With such a free energy source, the "plants" would naturally thrive and develop rapidly. These "plants" were primitive aquatic algae and it is

doubtful whether any terrestrial vegetation, other than possibly some low forms of fungi, existed before Cambrian times (Dorf, 1955, p.577).

Proposed sub-divisions of the Precambrian Era

From the foregoing discussion it is thought that the Precambrian can be divided into three major periods on the basis of probably atmospheric composition and stage of biological development. These periods are:-

1. The Pregeological Period

Duration:- up to 3000 million years ago. Accretion and consolidation of the earth. Loss of the proto-atmosphere, if any, and formation of a tenuous atmosphere of nitrogen, water vapour, carbon monoxide and dioxide by degassing of the earth's mantle. No free oxygen in the atmosphere. Locally strongly reducing conditions existed on earth. Life was generated during this period, resulting in the development of bacterial organisms. Primitive plants, capable of photosynthesis, developed towards the end of the Period. Probably a period of great crustal instability and volcanic activity. No geological record of this Period remains.

2. The Primitive Period

Duration:- from 3000 to 1000 million years ago. The atmosphere was denser and neutral to mildly oxidising. Oxygen partial pressure was kept very low by the oxidation of sedimentary materials. Rapid development of aquatic algae, fungi and primitive protozoa occurred during this Period. Local strongly oxidising or reducing conditions existed due, respectively, to the growth and decay of photosynthesising algae.

3. The Proterozoic Period

Duration:- from 1000 to 500 million years ago. A more strongly oxidising atmosphere developed owing to the rapid evolution of aquatic plants. The development of soft-bodied, bottom scavenging worms, and fore-runners of the Crustaceans, probably took place during this Period.

It would appear that the restriction of the banded ironstones to the Primitive Period can be attributed in part to biological factors. It will be shown that the presence of the aquatic algae which flourished during this Period was a prime requisite in the deposition of the banded ironstones. The emergence of terrestrial flora and the rapid development of bottom scavengers (mud-eaters) during the Proterozoic Period changed conditions in both the source areas and the depositional basins to such an extent that the deposition of the Precambrian type of banded ironstones was no longer possible.

(b) Mode of formation

Numerous theories for the origin of the banded ironstones have been advanced, but only the fact that they were deposited in a sedimentary environment seems to be firmly established. Few geologists today believe that they are the products of secondary ferruginisation.

The characteristics of a sedimentary rock depend on several factors which include the following:-

1. The nature of the source rock.
2. Topography and weathering of the source area.
3. Mode of transportation of material to the depositional area.
4. Pattern of environments in the depositional area.
5. Distribution of tectonic elements over the source and the depositional areas.
6. Post-depositional changes.

Superimposed on these are factors of climate and ecology, factors, which, in the case of the banded ironstones, are of prime importance. The genesis of the banded ironstones, with special reference to those occurring in the Transvaal System, will be dealt with under these headings.

1. The nature of the source rocks

The iron and silica in banded ironstones could have been derived either by the normal processes of weathering of iron-rich rocks, or from magmatic sources. Van Hise and Leith (1911), in their study of the Lake Superior Iron Formation, considered normal weathering processes inadequate to supply the vast quantities of iron contained in the rocks. The close association of basic volcanics with iron formations led them to believe that the major portion of the iron and silica was contributed directly to the sea water by submarine volcanic activity. Wagner (1928) partly supported this view in discussing the origin of the Transvaal ironstones. Dunn (1935, 1941) also stressed the close association of volcanics with the Indian banded ironstones. He considered these rocks to have originated from bedded ferruginous tuffs which had suffered pene-contemporaneous silicification by hydrothermal solutions and later reconstitution by supergene processes. Recently a magmatic source of iron and silica was again strongly advocated by Goodwin (1956) for the Gunflint Formation of Michigan and by Oftedahl (1958) in his study of welded tuffs and similar pyroclastics. Oftedahl argued that, based on the known close association of banded ironstones with basic volcanics, the only reasonable explanation for the sudden appearance of large quantities of iron and silica in the sea, precipitating as sedimentary ironstones, is that the iron and silica were contributed directly to the sea water by submarine volcanic exhalations. Numerous banded ironstones, however, show no signs of contemporaneous

igneous activity (Pettijohn, 1957, p.459). The basic lavas associated with those of both the Transvaal and Swaziland Systems have either pre- or post-dated their deposition. A similar relationship of lavas to banded ironstones is noted in the Lake Superior region by James (1954, p.276), and in the Canadian Shield (Belcher Island) by Bruce (1945, p.592-593).

A comparison of the trace element abundances in the Banded Ironstone Zone of the Lower Griquatown Stage with those of the associated basic igneous rocks shows very clearly that the material constituting the banded ironstones must have undergone processes of trace element fractionation. This would not have been possible if the material were contributed directly to the water in the depositional basin during the extrusion of the basic igneous rocks. Krauskopf (1955) has shown that the heavy trace elements are undersaturated in normal sea water because natural processes cause their virtually complete removal. If the heavy trace elements had been present in the depositional basin, one would have expected to find most of them precipitated together with the banded ironstone.

Gruner (1922), Gill (1927), Thiel (1927) and James (1954) have indicated that under tropical or subtropical climatic conditions in the presence of minor amounts of organic matter, normal chemical weathering of basic rocks supply adequate quantities of iron and silica to form banded ironstones. Gruner (loc.cit) notes that in 176,000 years the Amazon River, with an iron content of only 3 ppm., will transport a tonnage of iron equal to that contained in the entire Biwabik Formation of Minnesota, i.e. $1,940 \times 10^9$ metric tons. Since most banded ironstones are associated with older formations containing basic igneous rocks, usually lavas of basaltic to andesitic composition, it is probable that such lavas served as source rocks. In South Africa the extensive andesitic lava flows of the Ventersdorp System probably acted as source material for the banded ironstones of the Transvaal

System. It is possible that towards the north and the northwest the Basement Complex with its remnants of "older" banded ironstones and basic lavas may have served as a source if the Ventersdorp lavas did not extend so far.

2. Topography and weathering of the source area

The notable absence of detrital materials in banded ironstones suggests either a depositional area remote from land, or a source area of low relief. In South Africa, the presence of oolites in the Dolomite Series underlying the banded ironstone in the Northern Cape indicates shallow conditions where oolites could have been formed by wave action, while the stromatolitic algal growths in the dolomite also suggests shallow water conditions (Young, 1933; Fenton and Fenton, 1957). Evidence of the extreme shallowness of the depositional basin during the deposition of the Banded Ironstone Zone is provided by the occurrence of intraformational breccias at various horizons at Danielskuil and Kuruman. The absence of detrital material can consequently be related to a source area of very low relief.

From a study of soil profiles, Sakamoto (1950) deduced that in a generalised soil profile, the solutions above the water table would be acid, except in the arid regions or during the dry season. The soil solutions below the water table, on the other hand, would always be alkaline. He tried to explain the rhythmic layering of the banded ironstones on the basis of preferential seasonal leaching and precipitation. Under conditions of deep chemical weathering in a tropical, monsoon-type climate, iron, either as stable ferrous solutions or as organically stabilised colloids, would be transported in the acid surface waters during the wet season. Silica would migrate in the alkaline ground waters during the dry season. Alexandrov (1955) proposed a similar preferential seasonal leaching of iron

and silica due to the variations in humic acid content of the soil. During the cool wet season, the high humic acid content of the soil would favour the leaching of iron, whereas, in the dry, hot season, the decomposition of humic acids and the consequent alkalinity of the soil would favour the solution of silica.

It must be remembered that nearly all present day studies of soil profiles have been conducted in areas where vegetation is present, in contrast to the source areas of the banded ironstones where it was ^{probably} completely absent (except for algal growths in swamps and slow-running rivers).

The variations in the pH of soil solutions are very important in chemical weathering. The solubility of ferric hydroxide is directly proportional to the cube of the pH of the solution, its solubility at pH 6 being approximately 10^5 times greater than at pH 8. The solubility of silica, on the other hand, is little affected by changes of pH between 1 and 9 (Krauskopf, 1956). Especially significant is the control that the pH of the environment exerts over the solution and transportation of alumina. At a pH of less than 4, alumina is readily soluble, but it is practically insoluble between pH 5 and 9. This has a direct bearing on the formation of clay minerals during weathering. In acid environment, relatively much alumina as compared to silica is in solution, thus favouring the formation of kaolin, with $\text{Al}_2\text{O}_3 : \text{SiO}_2 = 1 : 2$. In alkaline soils the position is reversed and the formation of montmorillonitic clays is favoured, with $\text{Al}_2\text{O}_3 : \text{SiO}_2 = 1 : 4$. (Grim, 1953, p.342).

In the absence of humic acids, the main pH controlling factor of the Precambrian soil solutions is thought to have been the buffer system, $\text{CaCO}_3 - \text{CO}_2 - \text{H}_2\text{O}$. The seasonal variation of soil pH in the source area of the Lower Griquatown Stage could, therefore, have been from pH 6, during the wet season, to pH 8 during the dry season.

Virtually no alumina would thus have been in solution during either season, while most iron would have dissolved during the wet season.

Radioactivity decreases exponentially with time, and if the known decay constants of the radio-active elements are taken into consideration, it will be seen that the rate of radiogenic heat production and hence the surface temperatures of the earth, was much greater during the earlier geological periods than today. For example, the present rate of heat production by K^{40} in granitic rocks is 1 cal/gm/ 10^6 years, whereas 1000 million years ago the rate was 1.33 cal/gm/ 10^6 years and 4000 million years ago it must have been 3.65 cal/gm/ 10^6 years (Mason, 1958, p.284).

This higher surface temperature would have resulted in the tropical, monsoon-type weathering, i.e. deep chemical weathering, taking place in much higher latitudes than at present. Prolonged weathering under such conditions would have resulted in the near complete removal of silica and the concentration of alumina and iron at or near the surface as lateritic clays (Grim, 1953, p.342). The Precambrian lateritic soils, however, differed in one major respect from present day tropical soils. A large proportion of the iron in them remained in the ferrous state due to the neutral or very mildly oxidising nature of the atmosphere. The ferrous iron was probably present in minerals such as nontronite, siderite and weathered or degraded biotite. During the wet season large quantities of ferrous iron would have been dissolved out by the slightly acid rain waters while most of the alumina would remain behind in the soil.

The general lack of aluminium, vanadium, titanium in the banded ironstones of the Lower Griquatown Stage (apart from the stilpnomelane beds) and their relative abundance in the basal shales of the Pretoria Series at Pretoria, indicates that these elements remained behind in the source area and were only moved during periods of erosion. The

nature of the finer material remaining in the source area may be deduced from the composition of the stilpnomelane beds occurring in the banded ironstones. These beds are thought to be deposits of wind-transported material from the land area. The variable thicknesses of the beds, the absence of laminations, the presence of slightly graded microscopic quartz shards along bedding planes, and the extremely fine grain size, all indicate airborne transport. The presence of vanadium, manganese, titanium and chromium in the magnetites associated with the beds shows that the waters of the depositional basins suddenly acquired supplies of those elements which normally remained behind in the source area. In the absence of all terrestrial flora, one would expect extensive dust storms capable of transporting fine material over long distances. The amount of material transported would be especially marked during the periods of aridity since the clays would tend to bind the soils during the wet periods. Chepil (1957) has found that wind is a powerful sorting agent. Depending on the soil class, from 31% to 78% of all particles smaller than 0.1 mm. in diameter contained in a wind transported soil fraction are deflated by a single windstorm. The wind tends to remove the fine constituents from a soil, the coarser sand remaining behind in the wind eroded area. This sorting process, if continued even for a day or two, adds considerably to the general sandiness of the affected area.

A regolith of a composition identical to that postulated for the Precambrian lateritic soils was recently found in drill cores from the Vereeniging area. It consists of a 24 feet to 60 feet thick layer of vaguely bedded, greenish clay with numerous stringers and blebs of sideritic carbonate and small flakes of green biotite. It grades downwards with an increase in the abundance of biotite into unweathered amygdaloidal andesitic lava, thought to belong to the Ongeluk Stage of the Pretoria Series (i.e. the equivalent of the Middle Griquatown Stage). The upper contact is gradational to shaley Ecca sandstones with

scattered pebbles. No Dwyka Tillite is present in any of the holes which intersected the weathered lava. Microscopic examination of the rock shows that the biotite is of the emerald green, iron-rich variety. It is practically indistinguishable from that occurring in the metamorphosed stilpnomelane layer on Middelwater (Specimen G68P). In the more weathered upper portions of the regolith the "degraded" biotite is exactly similar in appearance to stilpnomelane. The presence of green biotite in the "lateritic" soils, thought to have formed from andesitic lavas during the Precambrian, would account for the general lack of potassium in the banded ironstones derived from them and its presence in large amounts in the stilpnomelane beds.

3. Mode of transportation

(i) Solution and transportation of iron and silica

Gruner (1922) and Moore and Maynard (1929), after numerous experiments, came to the conclusion that iron and silica are carried as colloidal solutions of ferric hydroxide and silica in natural waters. They found that, although hydrosols of silica and iron are capable of mutual precipitation, the addition of small quantities of peat solution, pH 4, stabilised mixed sols for long periods of time. Natural streams, with an organic content of only 4.5 ppm., could easily transport up to 30 ppm. SiO_2 and 10 ppm. Fe_2O_3 as colloidal hydrosols. The recent introduction of the molybdate method for distinguishing between SiO_2 in colloidal and true ionic solution, however, has enabled Krauskopf (1956, p.15) to show that most of the silica in natural waters is in true ionic solution.

Primitive algal growths must have been rife in the swamps and the slow, mature rivers which drained the source areas of banded ironstones. As the water level dropped during the dry season, much of this

algal growth would have been deposited on dry banks. The return of wet conditions and the increase in water level would have resulted in a high proportion of decayed, organic matter in the rivers, resulting in a marked lowering of the pH. Iron in the finely divided "lateritic" material washed into the rivers from the land surface would have been dissolved out by the acid waters and transported as stable ferrous solutions. Some of the iron may have become oxidised and this could then be transported as organically stabilised ferric hydrosols. As the rapid flow of water slowed down during the dry season, renewed growth of algae would cause the pH of the water to increase rapidly by the photosynthetic abstraction of CO_2 . No iron could either be dissolved or transported during this season.

The solubility of silica being largely independent of pH, its transport by the river water would not have been affected by the seasonal changes in pH, provided the silica was in true ionic solution. Krauskopf (1956) has shown that supersaturated solutions of colloidal silica slowly revert to ionic solution until the concentration of the latter reaches 100 ppm. Since the total silica content of most natural waters is only of the order of 70 ppm., it would all have been in ionic solution.

(ii) Solution and transportation of other constituents of banded ironstones

Apart from iron and silica the sluggish rivers must also have transported other salts in solution as well as clay and organic particles of colloidal dimensions. During deep lateritic weathering most of the sodium, magnesium and calcium is leached out first to be followed by silica, while iron and alumina is concentrated at surface (Grim, 1953, p.342). Most of this calcium and magnesium was probably precipitated in the depositional area during the carbonate phase which preceded the deposition of the banded ironstones of the Transvaal System.

A considerable amount of sodium, calcium and magnesium would, however, have been available during the banded ironstone phase because of continued chemical weathering at deeper levels. During the wet season the alkaline earths were probably transported as soluble bicarbonates, but during the dry season the photosynthetic abstraction of CO_2 from the river waters by algae would have caused their precipitation as insoluble carbonates. The solubility and transport of sodium, on the other hand, would have been unaffected by seasonal changes of pH. Potassium, however, remained "fixed" in the source area together with the alumina as indicated in the previous section.

The transport of colloidal clay and organic particles were probably also unaffected by seasonal pH changes, but the enhanced flow during the wet season would naturally have transported a greater amount of these materials.

4. The pattern of environments in the depositional area

(i) Fresh water vs. marine depositional environment

Opinion is divided as to whether banded ironstones were deposited in fresh water or marine environments. A number of geologists, notably Sakamoto (1950), Tyler and Twenhofel (1952), Alexandrov (1955) and Goodwin (1956) have postulated fresh or brackish water depositional basins, possibly with restricted access to the open sea, whereas James (1954) enumerates a number of arguments in favour of marine depositional environments.

Hall (1930), du Toit (1945) and Willemsse (1959) proposed a marine depositional environment for the Lower Griquatown Stage, but the trace element distribution, notably the presence of chromium and the total absence of boron, seems to indicate a fresh water or, at most, a brackish water environment.

At present the evidence is insufficient to prove conclusively either a marine or a fresh water depositional environment. The writer is inclined to the view that deposition took place in a brackish water environment.

(ii) Precipitation of iron and silica

Moore and Maynard (1929) extended their experiments on organically stabilised sols of iron and silica to determine the conditions of their precipitation. The addition of electrolytes in the same proportion as in sea water caused the immediate flocculation of ferric hydroxide, but the greater part of the silica remained stable. Only after the elapse of four months was a layer of gelatinous silica visible on top of the precipitated ferric hydroxide. They also observed that a mixture of freshly precipitated colloidal silica and ferric hydroxide settled at different rates. The ferric hydroxide together with some entrained silica settled first and was followed at a much slower rate by the bulk of the silica. The presence of electrolytes enhanced this differential settling rate. Moore and Maynard concluded that the different coagulation rates of ferric hydroxide and silica hydrogels acting in conjunction with their differential settling rates would cause the observed rhythmic alternations of iron and silica in banded ironstones.

Gruner (1922) also noted the slow precipitation of silica from solutions with the composition of natural sea water, and he related the rhythmic layering of the banded ironstones to the action of algae and bacteria. These organisms used the organic colloids for their life processes and the iron or silica in building their cells or sheaths. He reports the presence of certain microstructures, which he considers to be algal remains, in the Biwabik Iron Formation. These structures consist of groups or chains of minute concentric rings

made up of chert with fine dustings of carbonaceous material. Spencer and Percival (1952) describe similar microstructures from the Indian banded ironstones, but consider them to be inorganic spherulites. Hawley (1926) raised the possibility that they represent inorganic osmotic growths. He showed that similar structures could be grown from ferrous sulphate crystals in a colloidal medium of sodium silicate. Gruner's observations have since been vindicated by chemical proof of the existence of algae during the deposition of the Biwabik Formation. Certain modern bacteria are known to cause the precipitation of ferric hydroxide, and they may well have been partly responsible for the precipitation of some of the iron in banded ironstones.

Sakamoto (1950) and, more recently, Huber and Garrels (1953) have suggested that the precipitation of the components of the ironstones is directly influenced by the prevailing pH of the water in the depositional basin. Sakamoto proposed the following cyclic deposition of banded ironstones in large, shallow lakes, probably with restricted access to the open sea:

During the wet season weakly acid, iron-bearing solutions are supplied to the lake. Fe^{++} is oxidised to Fe^{+++} in the well aerated water of the lake which has been convectively stirred by the influx of cool surface waters. In the dry season the influx of surface waters is stopped and the pH of the lake gradually rises to neutral. Ferric hydroxide is rapidly and completely precipitated. Due to evaporation and seepage of ground waters, the lake water becomes increasingly alkaline. Silica, supplied by the alkaline ground waters, gradually increases in concentration as the lake level drops. Silica and ferric hydroxide combine to form iron silicates and the increasing temperature of the water favours the precipitation of iron carbonates. With the return of the next wet season and the consequent influx of acid surface waters, the silica in the lake is totally precipitated and a new cycle starts. Fig.9 illustrates how, by repeating only half the cycle or

the full cycle, variations of pure chert, ferric hydroxide, iron carbonate or silicate can be obtained:-

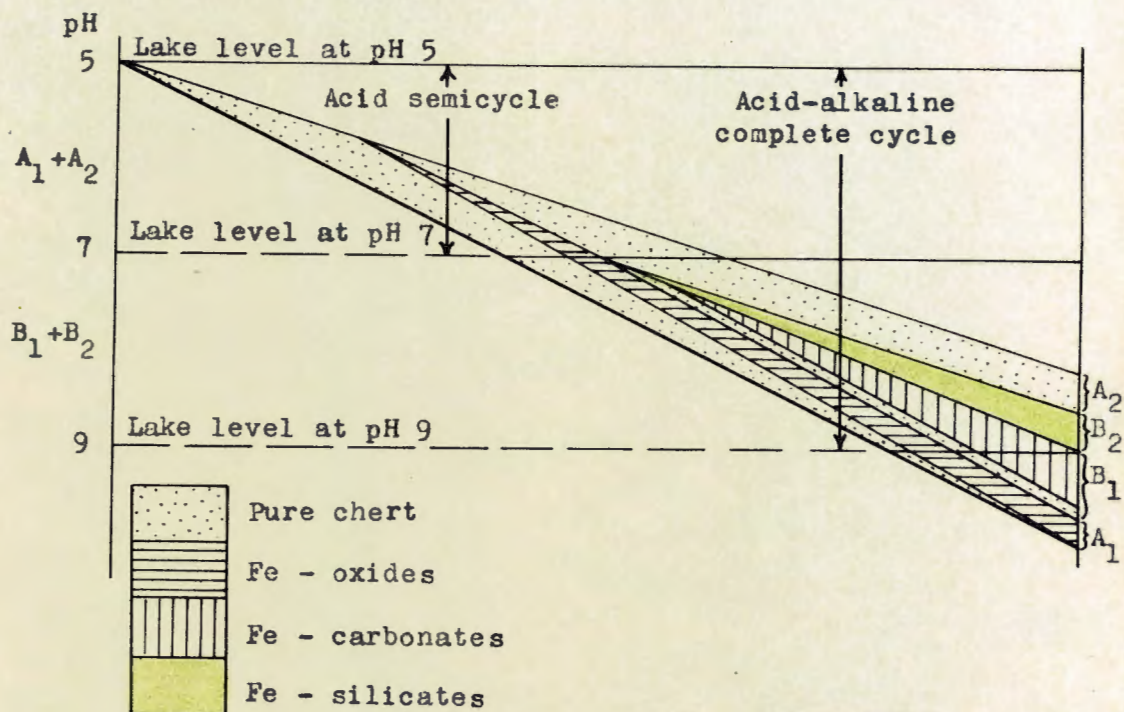

Fig.9. Cycles of iron deposition after Sakamoto (1950, p.468).

Sakamoto's postulated mode of deposition of ironstones appears very reasonable, but it seems unlikely that the pH of the water in the extensive basins in which the South African banded ironstones were deposited could have varied seasonally between the limits of 5 and 9 postulated by Sakamoto. Sea water normally has a pH which varies little from 8. If the basins were marine, no silica could have been precipitated since its solubility is roughly the same in sea water as in natural fresh waters, as shown by Krauskopf (1956, p.15). In dominantly fresh water basins, the solubility of silica also remains relatively insensitive to changes in pH.

Whatever the process of precipitation of silica, it is extremely effective, because, despite the fact that rivers annually contribute 320×10^6 tons of silica to the sea (Keunen, 1950, p.233), that is sufficient to give a concentration of 166,320 ppm., normal sea water contains between 2 and 4 ppm. silica (Rankama and Sahama, 1950, p.295). Lovering's (1922) experiments indicate that the precipitation of silica by natural sea water from solutions of sodium silicate is always incomplete and may not even take place if the solutions are slightly alkaline. Correns (1950) also states that concentrations of silica substantially greater than that carried by present day rivers cannot be flocculated by any known chemical agents, hence the silica of cherts and related rocks must have been biochemically deposited. The same conclusion was reached by Krauskopf (1956) in his review and experiments on the dissolution and precipitation of silica. Numerous post-Cambrian bedded cherts contain abundant remains of radiolaria, diatoms and siliceous sponge spicules. All traces of these delicate, relatively soluble, structures could easily be destroyed by the resolution and recrystallisation which most cherts and certainly all Precambrian cherts have undergone, and their absence need not necessarily preclude a biochemical origin of the chert.

It is thought that the chert bands of the banded ironstones were formed from the tests of animals similar to the present day radiolaria, diatoms and siliceous sponges. The deposition would have continued at a steady rate throughout the seasons, but it may have been increased during periods of flooding due to the catastrophic death of the near surface dwellers caused by the sudden influx of acid surface waters. Very little silica would be deposited during the period immediately following flooding until the new generations of protozoa reached maturity again.

In marine basins, the iron would have been chemically precipitated in the dominantly alkaline waters. This rapid precipitation of iron solutions in sea water has led a number of writers to postulate fresh water depositional basins in order to overcome the supposed dumping of the iron at the river mouths. Guild (1957) put forward the suggestion that, owing to the difference in density, the river water would float on top of the sea water for a considerable length of time. This would delay precipitation and result in a wide and relatively even distribution of the iron. He quotes the case of the fresh water from the Amazon River which can be traced for hundreds of miles out into the Atlantic Ocean.

In a shallow fresh water lake there would be a seasonal variation of pH controlled by the growth of algae. During the wet season the influx of weakly acid flood waters would lower the pH to near neutral. The disruption and extinction of colonies of algae by the floodwaters would further lower the pH, probably to nearly 6 since no CO_2 would be abstracted from the water by the plants. During the dry season renewed growth of the algae would increase the pH to near 8 by the photosynthetic abstraction of CO_2 . A similar seasonal pH fluctuation related to aquatic plants has been found in longshore basins with restricted access to the sea in South Australia (Alderman and Skinner, 1957).

It can thus be concluded that the silica was precipitated biochemically throughout the seasons while the iron was precipitated either by the seasonal fluctuation of pH in fresh water basins, where iron would be precipitated during the dry season, or by the dominantly alkaline environment in marine basins, where iron would be precipitated during the wet season. The writer is more inclined to the former view.

(iii) Deposition of other constituents of banded ironstones

If the waters of the depositional basins were typically "non-aggressive", i.e. allowed alkalis and alkaline earths to accumulate because of the slow movement of water through the basins, then these would have become concentrated during the dry season by evaporation of the lake waters. Towards the end of the season the increased pH and temperature of the waters would have caused the precipitation of the magnesium and calcium, probably in conjunction with the remaining dissolved iron, as ferro-dolomite. This would account for the observed association of ferro-dolomite with the chert-magnetite banded rocks in the Transvaal System. The sideritic granular carbonates associated with the stilpnomelane beds in this System are thought to be of extra-basinal origin. They were not chemically precipitated from the waters in the basin, but form part of an aeolian deposit. Sodium would have remained in solution in the brackish waters of the depositional basin. Long dry periods would have resulted in a relatively high concentration of sodium in the lake waters, a fact which assumes special significance in the deposition of the riebeckite-bearing beds, as will be shown in the following Chapter.

The clay and organic colloids supplied to the depositional basins would have remained in solution throughout the wet season in the weakly acid waters. During the dry season, however, the increasing concentration of electrolytes (Na, Ca, Mg, etc.) would have caused their flocculation and precipitation (Keller, 1936) in conjunction with the iron and alkaline earth carbonates.

(iv) Sedimentary facies of banded ironstones

Krumbein and Garrels (1952) showed that the mineral associations of chemical sediments bear a direct relationship to the limitations imposed by the oxidation-reduction potential and the hydrogen ion concentration of the environment. The stability of an element in any particular oxidation state depends on the energy change involved in adding or removing electrons. A quantitative measure of this energy change is known as the oxidation-reduction potential, that is Eh, which is a relative figure, the reference standard being the reaction

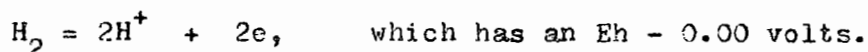

The Eh of a reaction varies with the concentration of the reacting substances. This is of particular importance in any reactions involving hydrogen or hydroxyl ions. In such reactions, variations in the pH would produce large changes in the Eh. The range of Eh in natural aqueous media is theoretically limited by the two reactions

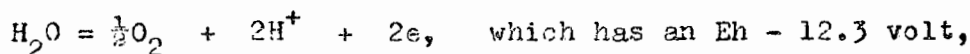

and

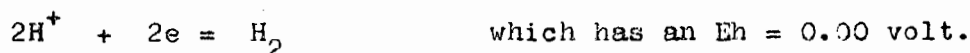

Both these reactions involve hydrogen ions and their Eh's are therefore strongly influenced by pH. The reaction

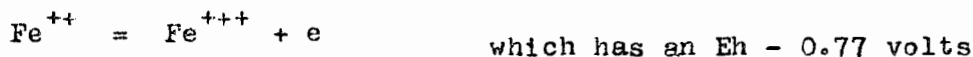

in acid solution and is unaffected by pH changes as long as no ferric hydroxide is precipitated, is of special interest. In normal sea water the ratio of $\text{Fe}^{++}/\text{Fe}^{+++}$ is controlled by the Eh along, whereas the concentration of CO_3^{--} is dependent on the pH and S^{--} is controlled by both pH and Eh. Krumbein and Garrels (1952) broadly classified marine environments as normal; open circulatory; restricted, humid; and arid or evaporite; and showed that the association of minerals normally found in banded ironstones would tend to form in

a restricted, humid type of marine environment. James (1954) also concluded that banded ironstones were deposited in restricted, marine basins under abnormal conditions of pH and Eh.

In the Lower Griquatown Stage, the dominant iron minerals in the fresh rocks are magnetite, ferrous carbonates and silicates. Only in the underlying dolomites are hematite oolites found. The Eh at the sedimentary interface in the depositional basins was therefore always on the reducing side.

(v) Pattern of environments in the Transvaal System depositional area, with special reference to the Lower Griquatown Stage

The association of tillites with the Transvaal System, taken in conjunction with evidence of glaciation during the deposition of earlier and later systems, e.g. during Witwatersrand times (Wiebols, 1955) and Karroo times, makes the possibility of an ice-cap centered near South Africa seem very attractive. This ice-cap periodically advanced and retreated across Southern Africa throughout the Precambrian and right up to Carboniferous times.

The Transvaal Period is thought to have opened with the gradual inundation by ice-cap melt waters of a vast peneplane in a series of gently subsiding cratonic basins. Conglomerates and feldspathic quartzites of the Black Reef Series followed by dolomitic limestones of the Dolomite Series were deposited in steadily deepening basins. The conglomerate-feldspathic quartzite-carbonate facies is considered to be the products of sedimentation in shallow, but steadily deepening waters, marginal to a very low-lying, stable land surface (Pettijohn, 1957, p.613). In the Northwestern Cape (Richtersveld) the tillites, arkoses and dolomites of the Kaigas Formation, which has been tentatively correlated with the Transvaal

System, are thought to have been deposited under cold climatic conditions in such a steadily deepening fresh water lake (De Villiers and Söhnge, 1960, p.137). These authors believe that the "glacial or near-glacial environment would seem to be peculiarly favourable for the formation of calcareous rocks" (p.154). This is in direct contrast to post-Cambrian chemically precipitated carbonates. Cloud and Barnes (1957, p.179) consider that the most favourable environment for the accumulation of such deposits is one of warm, shallow, relatively sluggish marine waters where the sea bottom is undergoing slow, but continued subsidence. The close association of glacial and peri-glacial sediments with ironstones and dolomites, both in the Transvaal and the Lower Witwatersrand Systems, inclines the writer to agree with De Villiers and Söhnge.

The required sub-tropical, monsoon-type weathering is not necessarily precluded by the postulation of cold climatic conditions in depositional areas. As already mentioned, sub-tropical conditions of weathering would have occurred quite close to the ice-caps during the early Precambrian because of the high surface temperatures.

Subsidence in the basins must have been intermittent, as indicated by the emergence of the limestones and cherts in the Transvaal, where they suffered much erosion during the formation of the Bevet's conglomerate prior to the deposition of the overlying Pretoria Series. The latter Series was deposited in a cyclic manner in a basin which was intermittently deeper and shallower (Willemsse, 1959, p.xxxi).

Generally speaking, the whole Transvaal System is composed of shallow water facies, indicating that subsidence in the basins kept pace with the rate of sedimentation.

Prior to the emergent phase at the close of the carbonate depositional period, a series of large interconnected lakes are thought

to have lain in an arcuate belt running roughly in a north-easterly direction from Prieska in the Cape Province to Penge in the Eastern Transvaal. These lakes probably contained brackish water which was typically "non-aggressive". They must have been exceptional in their large areal extent and their permanence.

In such lakes the rhythmically layered banded ironstones of the Transvaal System were deposited. The perfect preservation of the layering in the banded ironstones indicates either the complete absence of mud-eating bottom dwellers, or deposition in quiet water, i.e. below the wave base, which, in inland lakes, is not very deep. Tyler and Twenhofel (1952, p.9) came to the conclusion that mud-eating bottom dwellers had not yet evolved when the Huronian banded ironstones were deposited and the same may be true for the Transvaal System. The layering is thought to indicate seasonal deposition, a band composed of iron together with minor amounts of silica, carbonates, clay and organic matter having been deposited during the dry season while mainly silica was deposited during the wet season. Bottom conditions were always stagnant, the decaying organic matter causing a negative Eh. Most of the iron supplied by the sluggish rivers was probably precipitated as ferric hydroxide in the predominantly alkaline-oxidising, dry season, surface waters, but was redissolved, reduced and re-precipitated, either directly as magnetite, or first as lepidocrocite (FeOOH) with subsequent dehydration to magnetite at the sedimentary interface where the waters were acid and reducing.

The hematite oolites in the dolomite immediately below the Banded Ironstone Zone at Ouplaas (Danielskuil) indicates the nearness of the strand line during the carbonate deposition, which took place just before the rate of subsidence in that particular basin overtook the rate of sedimentation, resulting in the quiet water deposition of banded ironstone.

The deposition of banded ironstones culminated in the return of detrital sedimentation which preceded the advance of an ice-sheet over the area. The great thickness (some 2,500 feet) of mudstone and shale in the Prieska area may well have been fine, glacial outwash from the advancing ice-sheet, but the writer has no direct evidence, such as the occurrence of rafted erratics, etc., to support this view. The ice-sheet must finally have extended as far as Prieska, depositing the tillite which overlies the Mudstone Zone.

The eventual retreat of the ice was followed by the extrusion, partly sub-aqueously, of vast quantities of andesitic lavas. Banded ironstone sedimentation conditions were repeated to a limited extent in the Northern Cape, but detrital sedimentation was dominant, indicating extensive tectonic changes in the source area.

5. Distribution of tectonic elements over the depositional and source areas

As outlined in the previous section, the banded ironstones of the Transvaal System were deposited in basins which were gently subsiding during a long period of relative quiescence. Towards the end of the period, gradually rising land in the source area caused rejuvenation of the rivers. A limited amount of detrital material was supplied to the depositional basins. At the same time, a vast ice-sheet was advancing from the north, depositing glacial outwash and tillites. In the Transvaal detrital sedimentation started earlier than in the Cape, resulting in the deposition of some 2,000 to 5,000 feet of shales and sandstones prior to the advance of the ice.

James (1954) relates the deposition of banded ironstones to the evolution of geosynclines. He maintains that banded ironstones are deposited in the restricted marine environment formed during the growth of a geosyncline between the land and the gradually rising off-

shore swell, which finally emerges as a volcanic island arc. The deposition ends in the massive outpourings of lava from the arc, to be followed by the deposition of graywackes and other typical eugeo-synclinal sediments. This mode of formation cannot be applied to the South African occurrences. The assemblage of conglomerate, feldspathic quartzite and carbonate, which underlie the banded ironstone, are typical cratonic basin deposits. Cratonic conditions of deposition for the detrital sediments of the Pretoria Series overlying the banded ironstones in the Transvaal are also advocated by Willemsse (1959, p. xxxii). In the Prieska area, the chloritic mudstone, which could be classed as a graywacke, occurs below the lavas and is separated from them by a tillite.

6. Post-depositional changes

The major post-depositional changes suffered by the "younger" group of banded ironstones are dewatering and recrystallisation caused by the increased pressure and temperature resulting from depth of burial. For the most part, especially those occurring in the Transvaal System of South Africa, they suffered very little metamorphism.

A minor amount of diagenesis, which should more correctly be termed "halmyrolysis" (Pettijohn, 1957, p. 649) since the changes probably took place while the sediments were still in contact with the water in the depositional basin, occurred in certain layers.

Among these changes are included:-

1. The solution of ferric hydroxide, its partial reduction by organic matter and reprecipitation, either directly as magnetite or as lepidocrocite, which was subsequently dehydrated to magnetite during dewatering.
2. The solution of the siliceous tests of protozoa and the redeposition of the silica, probably in a colloidal form.

3. The authigenesis of minnesotaite and sodium ferri-attapulgite (refer Chapter VII), probably as hydrated forms, by reaction of colloidal clay materials with Fe, Mg and alkali ions.
4. The secondary rims of carbonate material grown on original carbonate granules. The recrystallisation of originally precipitated black amorphous ferrous sulphide to pyrite.

The changes enumerated in 4 above, probably belong to the slightly later period of dehydration and recrystallisation when the sediments were no longer in contact with the water in the depositional basin. During this period the colloidal silica gradually lost water. Its recrystallisation to chert took place at a much later stage, probably only during the final dewatering and lithification of the rocks. The magnetite and pyrite recrystallised as perfect octahedra and cubes respectively, while iron silicates were partially dehydrated and recrystallised.

In the Banded Ironstone Zone of the Lower Griquatown Stage one cannot readily distinguish which minerals are truly the product of metamorphism. The mineral assemblage appears to be entirely due to diagenetic changes. Metamorphic energy was expended almost entirely on the slight enlargement of grain size by recrystallisation of the minerals already present and possibly the dehydration of sodium ferri-attapulgite to form riebeckite, as will be explained in the following chapter.

In the Malips Drift area of the Transvaal, the only recognisable metamorphic change, apart from the recrystallisation of the minerals, is the formation of grunerite at the expense of minnesotaite.

The occurrence of acmite at Prieska need not necessarily represent a metamorphic change since its formation is dependent on the oxygen partial pressure of the environment during its formation and it may be the product of low temperature authigenesis. Its occurrence in rocks with coarser-grained chert, larger magnetite grains and deep green biotite, however, seems to indicate that it is a metamorphic product of riebeckite.

VII. THE GENESIS OF RIEBECKITE

The presence of riebeckite in the Transvaal System and the Nullagine Series of Western Australia presents a special problem. Not only the presence of riebeckite in these two formations, but also its absence from other lithologically similar banded ironstones require explanation.

Metamorphism cannot readily be invoked to explain the presence of the so-called "stress" mineral, riebeckite, because not only did the rocks suffer virtually no thermal metamorphism, but it has also been shown that in South Africa the formation of riebeckite pre-dated the strong post-Matsap deformations. A detrital origin for the riebeckite, with subsequent recrystallisation, is also contra-indicated by the complete absence of recognisable detrital material other than the stilpnomelane layers in the riebeckite-bearing beds and also by the fact that in South Africa the Ventersdorp lavas, which probably served as source rocks, contain no alkali-amphiboles. One is thus forced to the conclusion that the riebeckite was formed by low temperature authigenesis.

Low temperature authigenic riebeckite has recently been recognised in the Eocene saline deposits of the Green River Formation of Wyoming. Milton and Eugster (1959, p.141), state that, "The presence of authigenic acmite and an intermediate member of the magnesioriebeckite - riebeckite series in the Green River Formation has been a surprise. They unquestionably have formed at or near room temperature...". The Green River Formation consists of great thicknesses of lacustrine sediments which are characteristically varved. The varves consist of pairs of laminae, each pair containing one lamina rich, and one poor in organic matter. The sediments consist typically of limestones, siltstones and carbonaceous or oil shales.

In the upper portion of the formation, numerous intercalated saline beds with peculiar mineral assemblages occur. Milton and Eugster (1959), in reviewing the literature on this formation, came to the conclusion that it was deposited in dominantly fresh water lakes of vast extent and permanence. Three huge, gently subsiding structural depressions on the Colorado plateau, the Green River basin in Wyoming, the Piceance Creek basin in Colorado and Uinta basin in Utah, received of the order of 7,000 feet thickness of fine-grained chemical and detrital sediments. The rate of subsidence generally kept pace with the rate of sedimentation, but at times exceeded it. The lakes were of the order of 100 feet or more deep, but where the oil shales accumulated they may have been over 1,000 feet deep. Towards the end of their existence increasing desiccation caused the water level in the lakes to drop below the outlets to the sea. Milton and Eugster sum up this late maturity period as follows:- (loc.cit. p.121-122):

"The formation of calcite and dolomite with evaporation left the lake waters enriched in sodium. With increasing desiccation... wide mudflats were intermittently exposed with crystallisation of saline compounds on the surface, and then flooded and buried in accretions of saline muds. The dissolved salts became concentrated into smaller and smaller basins, from which sodium, sodium-calcium, barium, and complex carbonates were deposited along with calcite, dolomite and pyrite. The desiccation of the lake was not a catastrophic occurrence, but rather an alternation of ever-shortening wet periods and lengthening dry ones. Thus a period of saline deposition would be succeeded by a period in which small amounts of sodium carbonates or none at all were deposited, so that saline beds are intercalated between varying thicknesses of almost or wholly non-saline beds".

The climatic and environmental conditions of deposition of the Green River Formation are remarkably similar to those postulated for the deposition of the Lower Griquatown Stage and it is thought that periods of desiccation may have resulted in the formation of the intercalated riebeckite-bearing beds in the banded ironstones of the Transvaal System. The idea that the riebeckite-bearing beds are attributable to pre-existing layers of saline muds was first put forward in 1918 by Hall and has since been re-affirmed by Peacock (1928) and Hall (1930). A modification of this idea was introduced by Miles (1942) and du Toit (1945), who considered that the soda from entrapped sea water was concentrated along certain clay-rich layers by cation exchange during the dewatering of the sediments. It is, however, doubtful whether the Lower Griquatown Stage was deposited in a marine environment. If simple cation exchange by clays had resulted in the eventual formation of riebeckite it should have been far more prevalent in other banded ironstones, certainly in the Lake Superior Region. The writer is more inclined to believe that special conditions of climate and environment led to the deposition of material which eventually formed riebeckite.

The authigenesis of riebeckite

Recent laboratory investigations by Ernst (1959, 1960) have demonstrated that magnesioriebeckite is only formed at low oxygen partial pressures. In fact the riebeckite stability field lies inside the $p.O_2$ limits defined by the "buffer" reactions:-

Hematite (Fe_2O_3) -- Magnetite (Fe_3O_4) -- Wustite ($Fe_{1-x}O$)
 as shown in the following diagram:-

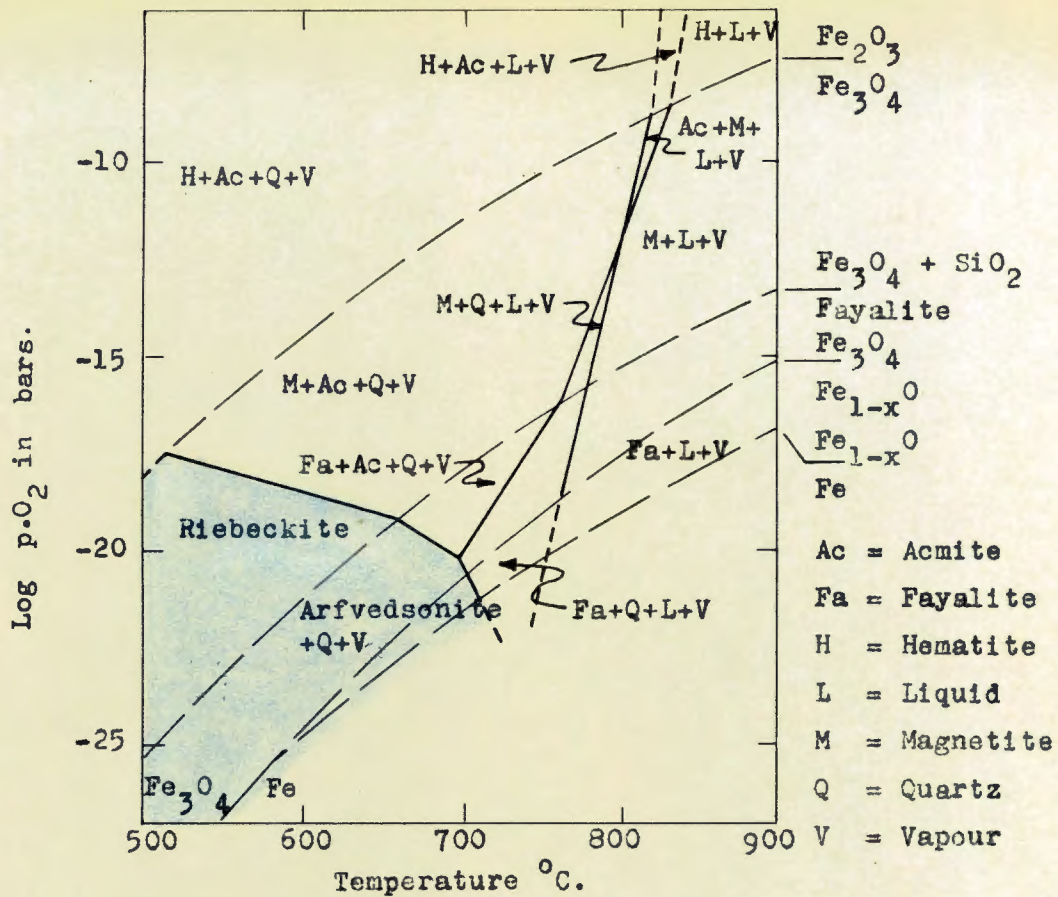

Fig.10. Stability field of riebeckite (Ernst, 1960)

Eugster (1959) has shown that in a buffered mineral assemblage for example, magnetite + hematite, the $p.O_2$ remains constant while the Fe:O ratio changes until either one or other of the components is used up. The constant association of riebeckite with magnetite in the Lower Griquatown Stage shows that, during the formation of riebeckite, the $p.O_2$ was kept within the stability field of riebeckite by the buffering action of the magnetite. Milton and Eugster (1959, p.141) also concluded that the riebeckite in the Green River Formation must have formed at a very low $p.O_2$ because of the presence of hydrocarbons.

A higher $p.O_2$ favours the formation of acmite (Ernst, 1960), which is of very restricted occurrence in the Transvaal System. Since the $p.O_2$, at which hematite forms, lies above the stability range of riebeckite, it is not surprising to find no primary hematite anywhere associated with riebeckite.

To the writer it seems unlikely that riebeckite could form from its component oxides at the low temperatures and pressures envisaged by Milton and Eugster. During crystallisation of a mineral assemblage, it is easier to form a random rather than an ordered array and indeed several simple phases rather than a single complex phase. This is particularly true at low temperatures in structures containing non-equivalent positions which do not differ greatly from each other in terms of crystal energy but which are occupied by different cations. Once a cation attains a "wrong" position there is insufficient thermal energy to move it to a stable position of lower energy; cf. ease of crystallisation of single cation carbonates as compared to dolomite, where alternating layers of Ca and Mg are sandwiched between CO_3 layers, (Goldsmith, 1959, p.355). Although riebeckite is stable at very low oxygen partial pressures, it nonetheless requires, for its formation, an appreciable total pressure and possibly an induction temperature (i.e. the energy level required to break the oxide structures and form them in an ordered silicate chain structure) in excess of room temperature.

It is considered far more likely that riebeckite formed from a more ordered precursor by simple dehydration and ionic reconstitution similar to the reconstitution of degraded (weathered) micas. This precursor or "proto-riebeckite" is thought to have been a clay mineral similar to attapulgite. Attapulgite is a member of the palygorskite-sepiolite group of clay minerals which are made up of amphibole-like Si_4O_{11} chains and hydrated, octahedrally co-ordinated

cation layers. Bradley (1940) determined the structure of attapulgite and considers the Mg end member to have the idealised formula:-

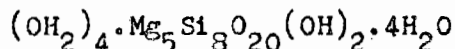

The structural scheme as determined by Bradley is illustrated in Fig.11. The structure of riebeckite is given for comparison.

Bradley (p.410) considers that some aluminium for magnesium substitution may take place in the octahedral layer, but that an aluminous end member is unlikely because aluminium in the octahedral layer weakens the structure. On the basis of available analyses of attapulgite, Marshall and Caldwell (1947) have shown that the five octahedral positions are likely to be occupied by 1.5 - 2 Mg⁺⁺, 1.7 - 1.9 Al⁺⁺⁺, 0.3 - 0.5 Fe⁺⁺ and Fe⁺⁺⁺ and small amounts of manganese and titanium.

If attapulgite formed in the source area of the Lower Griquatown Stage, it would have done so in a chemical environment rich in iron and could quite conceivably have contained 2 Fe⁺⁺⁺ ions instead of Al⁺⁺⁺ in the octahedral layer. This would have satisfied the basic requirement of 2 Fe⁺⁺⁺ ions in the octahedral layer of riebeckite. The Fe⁺⁺ : Mg⁺⁺ ratio at the time of transformation would have determined the position of the resultant riebeckite in the magnesioriebeckite - riebeckite series.

Attapulgite is built up from planar sheets of oxygen+silicon atoms with brucite layers, one amphibole unit wide, alternately above and below the oxygen sheets. This results in a structure composed of mica-like sheets with long channels, one amphibole unit wide and one brucite layer thick, parallel to the c-axis. The channels have an effective cross section of 6.0 x 3.7 Å. They are lined top and bottom by neutral O-Si ions and on the sides by highly polarised OH₂ molecules, which are co-ordinated onto the brucite layers.

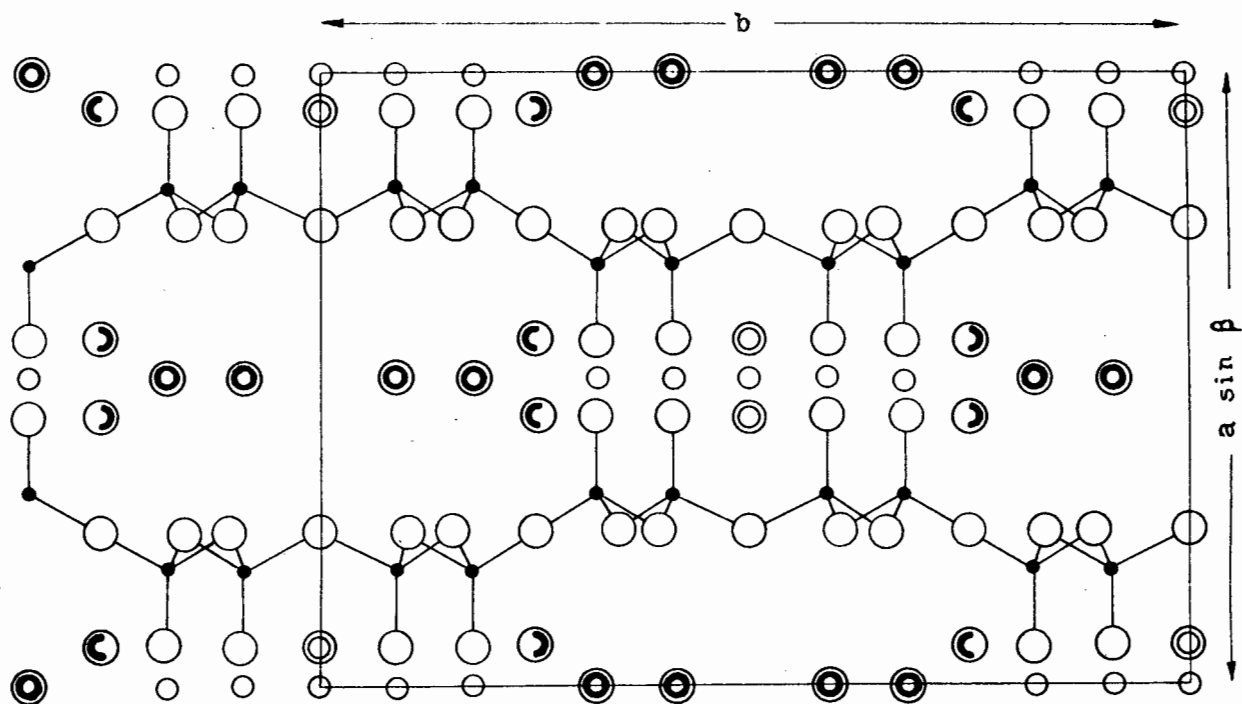

Structure of attapulgite after Bradley (1940)

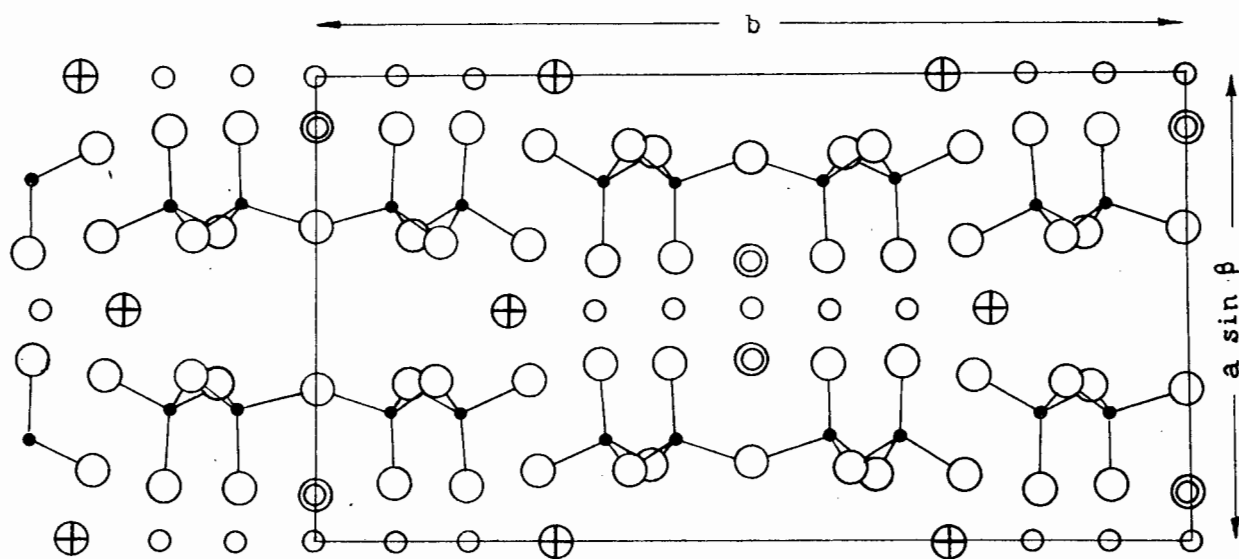

Structure of riebeckite after Whittaker (1949)

- Silicon
- Mg, Fe, Al
- ⊕ Sodium
- Oxygen
- ⊙ Hydroxyl
- ⊙ Water
- ☾ Co-ordinated water

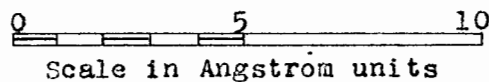

Fig.11. Structural schemes of attapulgite and riebeckite.

The channels are normally filled with water, 4 molecules per unit cell, but this water is easily lost below 100°C. With further dehydration the lattice shrinks normal to the c-axis as the coordinated water in the brucite layer is lost. The hydroxyls in the oxygen layers are not driven off below 500 - 600°C. when the structure collapses. Grim (1953, p.221-222) has found that in montmorillonitic clays the dehydration temperatures are reduced by large replacements of iron for aluminium. It is possible that a similar reduction of dehydration temperature will take place in attapulgite.

Marshall and Caldwell (1947) have shown that the channels in the attapulgite structure contain a nett negative charge of 0.14 - 0.16 equivalents per unit cell. This negative charge is normally satisfied by loosely held cations, and attapulgite therefore shows cation exchange properties. The exchange capacity is about 20 - 30 milliequivalents per 100 gms of clay, as compared to 3 - 15 milliequivalents per 100 grams in kaolinite and 80 - 150 milliequivalents per 100 grams in montmorillonitic clays (Grim, 1953, p.129). In a soda-rich environment iron-bearing attapulgite would therefore have accepted sodium and been deposited as sodium ferri-attapulgite.

Attapulgite is normally found in the same sedimentary environment in which low temperature authigenic riebeckite has been found in the Green River Formation, an environment similar to that postulated for the deposition of the Lower Griquatown Stage. It occurs associated with illite, chloritic mica and montmorillonite in lacustrine sediments of the "non-aggressive" type, but is particularly prevalent in sediments which have accumulated in dry desert lakes (Grim, 1953, p.356). It is significant that, in the flat, poorly drained Springbok Flats of the Central Transvaal, local concentrations of attapulgite, associated with montmorillonite has

been found (Heystek and Schmidt, 1953). The attapulgite was formed via montmorillonite by the weathering of amygdaloidal basalts of Karroo age and was concentrated in small areas (pans) by local transport.

On this argument it can be assumed that attapulgite formed more or less continuously during the weathering of the source rocks of the Lower Griquatown Stage. It was transported in colloidal form to the depositional area where it was deposited together with other minerals of banded ironstones. During periods of increased aridity, water levels in the lakes would have dropped considerably, alkalis and alkaline earths would have become concentrated resulting in the eventual precipitation of ferro-dolomite. Ferri-attapulgite supplied to the lakes during such periods would acquire sodium. In excessively dry periods minerals such as shortite ($\text{Na}_2\text{CO}_3 \cdot 2\text{CaCO}_3$) and trona ($\text{Na}_2\text{CO}_3 \cdot \text{NaHCO}_3 \cdot 10\text{H}_2\text{O}$) may have deposited along with sodium ferri-attapulgite, but this is doubtful. If they were ever deposited all traces of their presence disappeared during the dewatering and consolidation of the sediments.

It is thought that the riebeckite in the banded ironstones of the Transvaal System resulted from the low temperature dehydration of sodium ferri-attapulgite in an environment where the oxygen partial pressure was kept at a constant low figure by the presence of magnetite. The ferri-attapulgite deposited during normal conditions acquired no sodium and dehydration caused the formation of minnesotaite. This association of riebeckite with minnesotaite is further discussed in the following Chapter.

From the foregoing discussion it can be concluded that the riebeckite-bearing beds in the banded ironstones represent periods of desiccation. As in the case of the Green River Formation, these periods were not catastrophic events but alternations of increasingly

long dry seasons with short wet ones. This resulted in the observed greater concentration of riebeckite in certain layers. The minor amounts of riebeckite that occur throughout the succession probably represent minor dry spells when the soda concentration in the lakes was only slightly increased. The absence of riebeckite from most other banded ironstones can thus be attributed to higher rainfall and hence more "aggressive" lake waters during the entire period of their deposition.

VIII. THE FORMATION OF CROCIDOLITE

Riebeckite and crocidolite are identical in chemical composition and differ only in the physical form of the crystals (Vermaas, 1952). It is thought that they both crystallised from the same parent material, sodium ferri-attapulgitic, either as densely matted, fibrous spherulites to form mass-fibre riebeckite, or as perfectly-orientated fibrous crystals in crocidolite. The problem of the origin of crocidolite asbestos appears, therefore, to involve only those factors responsible for the perfectly parallel orientation of the riebeckite crystals in some but not in other layers of the same chemical composition.

The morphology of crocidolite seams differs completely from the usual form of cross-fibre veins. In most veins of asbestiform minerals, features on opposite contacts of the vein can be matched and variations in fibre lengths are reflected by a narrowing or thickening of the whole vein. This is in strong contrast to crocidolite seams where the two contacts are completely different and variations in fibre lengths are generally expressed along one contact only. The crocidolite invariably carries a thin magnetite capping along this contact, a feature not always found in veins of other asbestiform minerals. From these differences it may be concluded that crocidolite seams had a different

mode of formation to that of other types of asbestiform veins, as exemplified by chrysotile.

In previously published work on the origin of crocidolite, it has always been accepted as a fundamental premise that crocidolite was formed by the recrystallisation of non-orientated mass-fibre riebeckite layers. External factors which could have caused this recrystallisation were sought. The most serious objection, applicable to all these hypotheses, is that they fail to explain how layers of mass-fibre riebeckite came to be preserved between, and even adjacent to, layers of crocidolite. Such relationships persist in individual reefs along strike through folds and faults for distances of at least twenty miles.

The frequent association of crocidolite enrichments with sharp flexures in the strata (the so-called "rolls"), especially in the Lower Crocidolite Horizon of the Cape Province has led a number of authors, notably Du Toit (1945), to postulate a tectonic control for the formation of crocidolite. Equally numerous, however, are "rolls" which show no crocidolite enrichment, or crocidolite enrichments which bear no relation to the folding. It is thought that the formation of crocidolite is completely unrelated to dynamic stress. In Plate VIIIA, p.26, the layer of mass-fibre riebeckite below the crocidolite seam represents material of a suitable chemical composition for the formation of crocidolite. Despite the fact that the mass-fibre riebeckite layer was thickened by plastic flow from the flanks into the low pressure areas along the crest and trough of the fold, no crocidolite developed in the layer.

Taber (1916, 1917, 1924, 1926) conducted numerous experiments on the emplacement of fibrous material in veins and on the growth of crystals under external pressure. He came to the conclusion that when

material in a vein has access to its "mother liquor" only through sub-capillaries in the vein contacts, the material will grow as cross-fibre by actually pushing the wallrocks apart. Boydell (1926) considered this linear force of growing crystals inadequate to form veins, mainly on arguments of the effects of pressure on the melting points of minerals and the difficulty in ensuring a constant supply of supersaturated solutions to the growing ends of the fibres. Peacock (1928) also considered this linear force inadequate for the formation of crocidolite seams, but he did emphasise the point that the surface on which crystallisation took place exerted a strong control over the orientation of the resulting crystals. A similar "surface" control was advocated by Thiesmeyer (1937) in considering the cross-fibre growth in the Arizona Tremolite deposits.

The fact that features on opposite sides of most other (i.e. non-crocidolite) asbestiform veins can be matched up seems to substantiate Taber's conclusions. Whether the walls of the vein were actually pushed apart by the growing fibres, or whether the fibres grew in a reduced pressure area between walls which were slowly moving apart due to tensional conditions, is not known. The writer's porous pot experiment (Appendix 3) indicates that growing crystals can definitely exert a strong pressure when they have restricted contact with their "mother liquor". For most asbestiform veins it can be shown that the material in the vein came from the immediately adjacent wallrocks, possibly through sub-capillaries in the vein wall. This is simply a process of transfer, the amount of material per unit volume remaining constant. Only if the fibrous form of the mineral in question occupies a volume different from that of its parent material does pressure become a factor to be reckoned with. The transformation of sodium ferri-attapulgitite to riebeckite is accompanied by a volume reduction due to dehydration and lattice shrinkage, hence simple static pressure due to depth of burial would encourage the reaction. Fibres of crocidolite were thus formed in spite of the increased pressure since crocidolite and riebeckite occupy the same volume.

It is thought that crocidolite fibres grew by the addition of riebeckite to growth points which were contact with a magnetite screen. The latter was pushed ahead of the growing fibres into a plastic medium. In this the writer is in agreement with du Toit (1945, p.194). In contrast to du Toit (1945) and Peacock (1928), who both considered mass-fibre riebeckite to have preceded the formation of crocidolite, the writer believes that crocidolite pre-dates mass-fibre riebeckite. Hall (1930), Miles (1942) and du Toit (1945) considered that growth of crocidolite began on a divisional plane between unsuitable and suitable strata and was propagated through the latter until an unsuitable layer was encountered. From the specimens examined by the writer, it is apparent that growth only occurred when the divisional plane in question was occupied by a magnetite screen. Crocidolite also grew completely within suitable layers, where such layers were traversed by magnetite screens. In a number of crocidolite seams the growth did not necessarily stop only on contact with unsuitable layers but was halted by some other factor or factors while material suitable for transformation still remained (see Plates X, XIA, p.29, and XXIV, p.125). This remaining material later crystallised as mass-fibre riebeckite.

(a) A proposed theory of crocidolite formation

The formation of riebeckite from sodium ferri-attapulgitic can be compared with the crystallisation of a solid from solution. It is thought that the actual transformation was effected only above a certain induction temperature, probably near 100°C. but below 250°C. At temperatures in excess of 250°C. fayalite would have become the stable phase in the banded ironstones (Flaschen and Osborn, 1957, p.940). The transformation was probably accompanied by liberation of heat due to reduction in crystal energy in the new phase, this heat being comparable with the latent heat of crystallisation of a solid. Where

such a transformation point was in contact with a magnetite screen, the liberated heat would have been conducted away along the screen. The temperature in adjoining areas of the magnetite was thus raised to the induction level and more riebeckite formed with a consequent further increase in temperature. The whole process was propagated by a type of "thermal autocatalysis" (Saul, 1955, p.101), whereby the essentially exothermic transformation reaction in one area provided the necessary thermal energy level to initiate the reaction in an adjoining area, the transfer of thermal energy being facilitated by conduction in the magnetite screen. This process would only be operative as long as a temperature gradient existed in the magnetite screen. Once the magnetite screen became an isothermal surface crocidolite growth would stop. When the overall temperature of the country rock reached the induction level the remaining sodium ferri-attapulgitic would crystallise as mass-fibre riebeckite. The fibre lengths in any crocidolite seam formed in a layer with an adequate supply of sodium ferri-attapulgitic would thus be governed by the temperature gradient in its magnetite screen.

The sodium ferri-attapulgitic must have diffused through the magnetite screens, been transformed to riebeckite during its passage, and deposited on the fibre growth points. Sub-capillaries in the screen provided the restricted contact with the "mother liquor" required for fibre growth "a la" Taber. Space for the growing seam was provided both by the abstraction of sodium ferri-attapulgitic from the opposite side of the magnetite screen, and by the reduction in volume during its transformation. Material unsuitable for transformation was pushed ahead of the magnetite screen by pressure exerted by the growing crystals. This material moved out of the way, ahead of and to the sides of the growing bundles of fibre by plastic flow.

PLATE XXIV

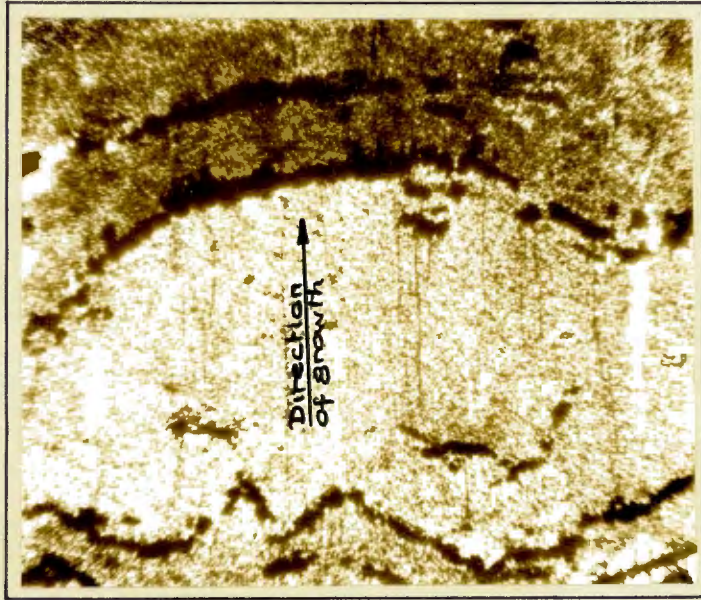

MOVEMENT OF MAGNETITE CRYSTALS
AHEAD OF GROWING FIBRES

Spec.G26D. Plane polarised light,
X 173 diameters.

Magnetite screens (black) pushed ahead
of and left within crocidolite seam
(light grey). Individual magnetite
crystals moved relative to one another
thereby causing no stretching of the
screen.

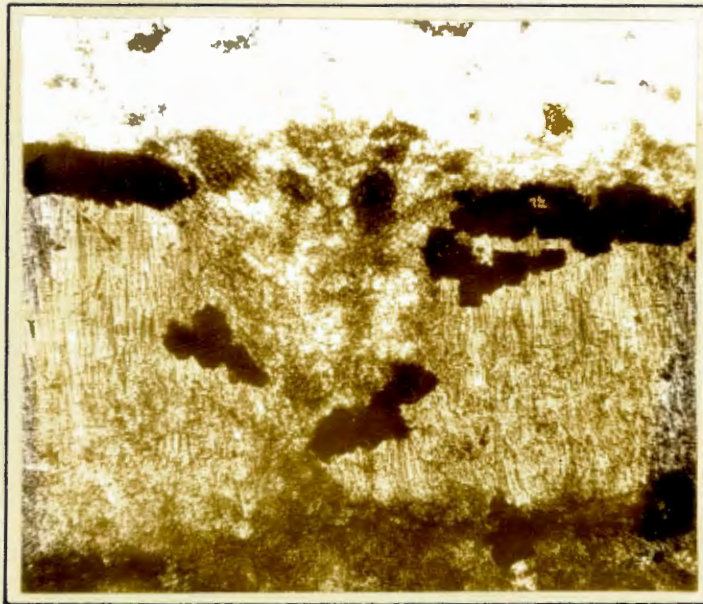

BREAK IN MAGNETITE SCREEN CAUSED BY
THE RAPID GROWTH OF FIBRES AT
ADJACENT POINTS

Spec.G88P. Plane polarised light,
X 408 diameters.

Note dark grey mass-fibre riebeckite with
scattered magnetite crystals (black) along
lower contact of seam and mass-fibre plus
chert in the inverted cone where cross-
fibres failed to form.

The whole process of crocidolite formation is envisaged as a wave of isothermal surfaces, inclined at an angle to the bedding, which moved slowly through the strata. The formation of crocidolite and mass-fibre riebeckite accompanied the induction temperature isotherm. The isotherms showed a very pronounced "dip" along the magnetite layers because of the latter's superior heat conductivity. The induction isotherm therefore moved along the magnetite layers a long way ahead of that in the adjacent strata with lower heat conductivity. Heat evolved by the riebeckite transformation reaction and heat dissipated into the adjoining strata could have caused the local reversal of the temperature gradient along the magnetite screens. Certain points would thus have remained at or repeatedly attained the induction temperature over long periods of time. It is thought that the typical cone-like growth surface of crocidolite seams are a result of this. The cones were formed at points where the temperature in the magnetite screen was kept at, or repeatedly attained, the transformation level. No stretching of the magnetite screens over these points was required since the individual crystals of the screen moved relative to one another as illustrated in Plate XXIV and Fig.12.

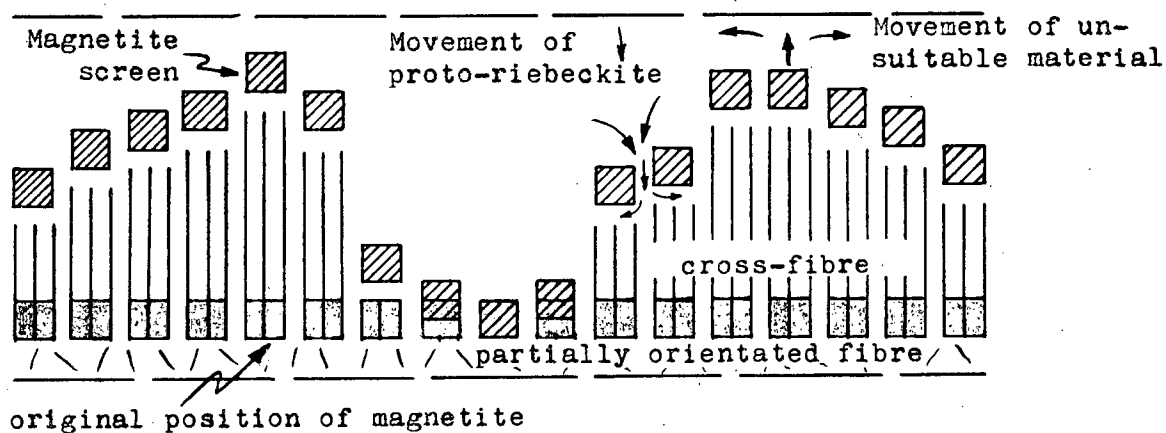
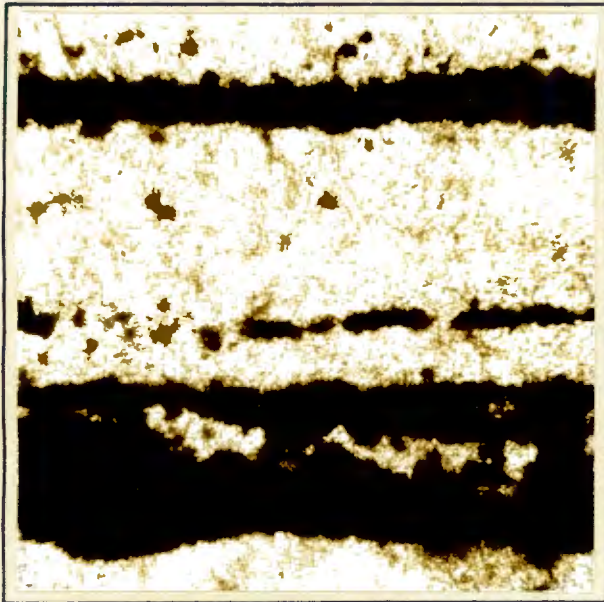

Fig.12. Schematic diagram showing the movement of the magnetite screen during fibre growth.

The contour-like ridges usually found on cones (Plate IXA, p.29) result from this differential movement in the magnetite screens. Plate XXV shows the actual breaking of the screen by the rapid growth of fibres at adjacent favourable points.

. The whole process was triggered by the transformation of the sodium ferri-attapulgitite in close contact with the magnetite screens, either interstitial in the case of thick screens, or immediately adjacent in the case of thin screens (Plate XXVIA). This initially transformed material would be only partly orientated by the "surface" action of the magnetite crystals as illustrated in Plate XXVIB, where the whole layer attained transformation temperature too rapidly for crocidolite to form. This partly orientated crocidolite is invariably found along the planar contact of singly convoluted seams or as a medial parting in doubly convoluted seams. The reduction in volume in or adjacent to the magnetite screen caused by this initial transformation would start the diffusion of unchanged sodium ferri-attapulgitite to, and eventually through, the magnetite screen, where it would transform to riebeckite. Since no stretching of the magnetite screens takes place, the number of riebeckite molecules which can crystallise per unit area of magnetite remains constant, therefore perfectly parallel fibres of riebeckite would be formed, irrespective of the attitude of the magnetite screen, or the magnetite crystals therein.

The source of the wave or waves of heat which triggered crocidolite growth is not known. Isothermal surfaces which passed through the strata at high inclinations to the bedding have been deduced from the metamorphism of the Iron Formation of the Lake Superior Region (James, 1955). These waves of heat came from three widely spaced centres. No large intrusions or traces of such intrusions could be found in these centres and James concluded that the waves of metamorphosing heat must have come from "subjacent intrusions".



Spec.G88P. Plane polarised light, X 487 diameters.

Note partial orientation of fibrous riebeckite in contact with magnetite, but failure to develop crocidolite in the intervening mass-fibre.

A. CONTROL OF FIBRE ORIENTATION EXERTED BY MAGNETITE ON INTERSTITIAL OR IMMEDIATELY ADJACENT RIEBECKITE

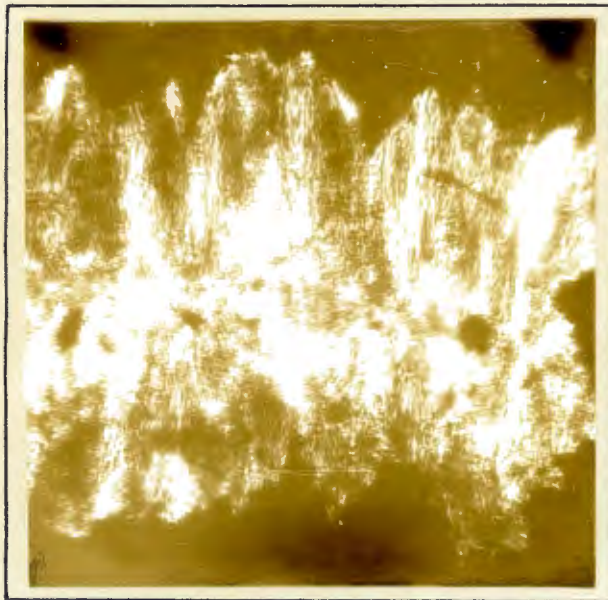

Spec.G88P. Plane polarised light, X 2105 diameters.

Note central parting of scattered magnetite crystals and chert similar to that found in the central parting of seams with both surfaces convoluted.

B. CONTROL OF FIBRE ORIENTATION BY MAGNETITE SURFACES

In the case of the Lower Griquatown Stage, the increase in temperature required for the formation of crocidolite was so minor that depth of burial of a few thousands of feet would have been quite adequate to supply the necessary thermal level. If, as postulated in the following section, the strata were already folded, temperature gradients would have been set up in the strata due to differences, however slight, in the depths below surface of individual layers.

The time of crocidolite formation cannot be firmly established. It took place while the rocks were still in a relatively plastic state. The pure chert layers may have been partly consolidated, but the silicate layers were still in a highly plastic state. Crocidolite formation was definitely complete before the strong post-Matsap folding took place.

(b) The formation of economic crocidolite deposits

From the foregoing theory of formation, it follows that economic crocidolite deposits would have developed where sufficient layers of sodium ferri-attapulgitic of adequate thickness were in close contact with magnetite screens. Where such a sequence originated during the primary deposition of the material, economic deposits were formed which are in no way related to tectonic features. These deposits are usually very extensive but not as rich as those which do show a relation to tectonic features.

Mention has already been made of the association of crocidolite enrichments with the so-called "rolls". Such deposits are generally richer, but of much smaller areal extent than the first mentioned ones. These associations are thought to be due to a period of gentle folding which took place prior to the formation of crocidolite. It may even have been due to slumping in the strata

immediately after deposition. The highly plastic sodium ferri-attapulgitic layers were thickened in the crests and troughs of these folds. The early folding was, in most cases, either accentuated or obliterated by the intense deformation of post-Matsap times.

A further control on the formation of economic crocidolite deposits was exerted by the temperature gradients in the magnetite layers during the transformation period. Thick seams were formed only where the requisite temperature gradients were maintained for a long time or where they were frequently repeated. Where these conditions were not fulfilled only mass-fibre riebeckite was formed.

There appears to be no way of predicting the location of economic crocidolite deposits. Meticulous mapping to determine the location of the earlier folds may reveal enriched deposits of the second type, but in addition to the primary depositional control there is also the thermal control. Deposits which were chemically suitable may not have had the correct thermal history.

(c) Association of crocidolite and amosite in the Transvaal

In the Pietersburg District of the Transvaal, notably at Malips Drift, a number of crocidolite-bearing reefs display a close association of crocidolite and amosite, the cross-fibre form of grunerite. Normally the crocidolite seams within the reefs are accompanied by seams of amosite, either above or below, but separated from, the crocidolite by bands of barren ironstone. Frequently, however, crocidolite seams occur capped on one or both sides with amosite, the fibres of both types of asbestos being in crystallographic continuity. This association gives rise to the handsome "doublet" or "triplet" seams found in these fields. An even closer association of crocidolite with amosite is found in the so-called "Lavender-Blue" asbestos seams. In these seams, crocidolite and amosite fibres

occur mixed in the same seam, the fibres all being parallel and appearing to have grown contemporaneously.

The writer did not make more than a cursory study of these associations. Taking into account the known absence of grunerite in the Cape and the apparent absence of minnesotaite in the Transvaal, it would appear that minnesotaite and grunerite had a common parent mineral and that they represent the different grades of metamorphism undergone by this parent mineral. Using the same reasoning as in the case of the riebeckite parent material (p.115), it can be argued that the parent mineral must have been a clay-mineral similar to the hypothetical ferri-attapulgitite. If this were the case, then crocidolite, minnesotaite and grunerite all had a common ancestor, ferri-attapulgitite, which formed during weathering in the source area and was transported to the depositional area in colloidal form. The subsequent history of the ferri-attapulgitite would determine whether riebeckite, minnesotaite or grunerite were formed. In a soda-rich environment, during periods of aridity, sodium ferri-attapulgitite would be formed which, on dehydration, would change to riebeckite. During wetter periods, the lakes would contain fresh water and no changes would be effected in the constitution of the ferri-attapulgitite. Dehydration would change it to minnesotaite, which would in turn change to grunerite during metamorphism.

It would appear that climatic conditions during the deposition of the banded ironstones were generally drier in the Cape than in the Transvaal where, at Penge, sodium was never concentrated in the depositional basin, as indicated by the complete absence of riebeckite. Malips Drift was located in the transitional area between the two extremes of climate. The initially low sodium content of the lake in this area was rapidly depleted by the deposition of ferri-attapulgitite. Beds of ferri-attapulgitite, which decreased rapidly upwards in sodium content, were thus deposited.

From the known association of riebeckite with either minnesotaite or grunerite, it may be concluded that the transformation of ferri-attapulgitite to grunerite required a slightly higher induction temperature than the sodium ferri-attapulgitite, riebeckite transformation. The formation of amosite may thus have taken place in the same way as crocidolite except that a higher induction temperature was required. On this assumption, doublet and triplet seams would have resulted from the gradually increasing temperature causing the growth of amosite through the same magnetite screens that had previously served for the growth of crocidolite, but only after transformation of all the available supply of sodium ferri-attapulgitite. In most specimens examined the later severe deformation suffered by the Transvaal rocks obscured the relationship of magnetite screens to asbestos, but remnants of a magnetite screen can be seen capping a doublet in Plate XIIB, p.30.

The association of contemporaneous crocidolite and amosite in the "Lavender-blue" seams does not appear to fit in with the supposed later growth of amosite. It may be that these seams resulted from a much steeper temperature gradient along the magnetite screens. The induction temperature of the grunerite reaction would then have been reached very shortly after that of the riebeckite reaction. Under these circumstances the growth of amosite would have started immediately after crocidolite and the two types of fibre would have continued growing together from the same magnetite screen. The available sodium in such seams would all have gone into the formation of crocidolite, the remaining ferri-attapulgitite forming amosite, since there is an immiscibility gap between the alkali and the cummingtonite-grunerite amphibole groups.

In bands where the sodium content of the ferri-attapulgitite decreased rapidly upwards, either crocidolite or "Lavender-blue" asbestos, with a capping of amosite, would have been formed, depending on the initial sodium content and the steepness of the temperature gradient in the magnetite screens. Examples of both types are found in the Malips Drift area.

CONCLUSIONS

A brief summary of the main conclusions arrived at in the final three chapters follows:-

(a) The genesis of Precambrian banded ironstones

1. No banded ironstones are known to be younger than 1000 million years.
2. They were deposited during a period between 1000 and 3000 million years ago, the so-called Primitive Period of the Precambrian.
3. During this Period, surface temperatures were generally higher than today due to the greater rate of radiogenic heat production; the atmosphere was less dense and neutral to mildly oxidising; primitive aquatic algae, protozoa and fungi flourished, but no terrestrial flora or fauna existed.
4. Banded ironstones were derived from the chemical weathering of basic igneous rocks in a tropical to sub-tropical monsoon-type climate.
5. Solutions of iron, silica, alkaline earths and sodium, as well as clay and organic particles of colloidal dimensions were transported to the depositional area by sluggish, mature rivers. Potassium and alumina tended to remain behind in the source area, as indicated by the chemical composition of the stilpnomelane layers, which are thought to represent aeolian deposits.
6. The components of banded ironstones were rhythmically deposited in seasonally fluctuating, typically "non-aggressive" fresh to brackish water lakes.

7. Iron was chemically precipitated in the predominantly alkaline-oxidising environment while the precipitation of silica was probably biochemical. Alkaline earth carbonates were chemically precipitated during the dry season when the increased concentration of electrolytes in the water also caused the flocculation and precipitation of clay colloids.
8. Stagnant conditions existed below the sedimentary interface, the decaying organic matter giving rise to an acid-reducing environment.
9. The deposition of banded ironstones ceased when extensive tectonic changes in the source area caused the return of detrital sedimentation. These changes were frequently accompanied by the extrusion of basic lavas, partly sub-aqueously in the depositional area.

(b) The genesis of riebeckite

1. Riebeckite in the Lower Griquatown Stage of the Transvaal System was formed by the low temperature dehydration, in situ, of an ordered precursor in an environment where the oxygen partial pressure was kept at a sufficiently low figure by the presence of magnetite.
2. The ordered precursor is thought to have been a clay mineral similar in structure to attapulgite, but containing ferrous and ferric ions in the octahedral layer.
3. Ferri-attapulgite was deposited more or less continuously but during dry spells, when the sodium concentration in the depositional lakes increased, it acquired soda by base exchange.

4. Dehydration of sodium ferri-attapulgitite resulted in the formation of riebeckite while ferri-attapulgitite without sodium formed either minnesotaite or grunerite, depending on the temperature at the time of dehydration.

(c) The formation of crocidolite

1. Crocidolite has a different mode of formation to that of other asbestiform veins as exemplified by chrysotile.
2. The formation of crocidolite is completely unrelated to dynamic stress.
3. Crocidolite formed only where bands of proto-riebeckite were traversed by, or in close contact with, magnetite layers.
4. Crocidolite grew by the addition of riebeckite to the fibre growth points which were in contact with the magnetite screens.
5. It is thought that proto-riebeckite diffused through the magnetite screens, was transformed to riebeckite during its passage, and deposited on the fibre growth points.
6. Slight temperature gradients in the magnetite screens induced by differences in depth of burial initiated the formation of crocidolite, the process being propagated by a type of thermal autocatalysis.
7. Crocidolite and mass-fibre riebeckite were both formed from sodium ferri-attapulgitite in a slightly exo-thermic reaction when a certain temperature level was exceeded, the so-called induction temperature.

8. Long fibres grew where the induction temperature was maintained or repeatedly attained in a magnetite screen. As soon as the adjoining strata attained the transformation temperature, mass-fibre riebeckite formed from the remaining sodium ferri-attapulgitite.
9. Economic deposits of crocidolite formed where a sufficient number of proto-riebeckite layers were in close contact with magnetite screens, which maintained the induction temperature for a long time.
10. The association of crocidolite and amosite in the Transvaal is thought to be due to a rapid decrease in soda content of the original ferri-attapulgitite layers.
11. Amosite formed in the same way as crocidolite when the sodium content of the ferri-attapulgitite was too low to form riebeckite.
12. The induction temperature for the ferri-attapulgitite to grunerite reaction is slightly higher than that for the sodium ferri-attapulgitite to riebeckite reaction.

ACKNOWLEDGMENTS

To my wife, my warmest thanks for her constant encouragement, and for undertaking the task of typing this thesis. To my father, my sincere gratitude is due for his encouragement and unfailing financial assistance.

Grateful acknowledgment is made to Mr. H.C. Vintcent and Dr. S.R. Taylor, both formerly of the Department of Geology at the University of Cape Town, for useful suggestions, help with chemical problems and stimulating discussions. Thanks are also due to Dr. A.O. Fuller for critical reading and discussion of the manuscript, Prof. E.S.W. Simpson, Dr. M. Mathias and the staff of the Geological Department, University of Cape Town, especially to Miss J. Carter for spectrographic analyses and to Mr. W. Cloete for making slides.

The writer wishes to acknowledge the co-operation of Messrs. Union Corporation Limited and Messrs. Murray and Stewart Limited in allowing the use of field data, the Council for Scientific and Industrial Research for a financial grant and the local managements and staffs of the various mines visited. To Mr. J.J. le R. Cilliers, the writer wishes to express his indebtedness for the useful information regarding the upper portion of the Lower Griquatown Stage in the Prieska area and for stimulating discussions on the origin of asbestos.

REFERENCES

- AHLFELD, F. (1943). Los yacimientos de crocidolita en las Yungas de Cochabamba.
Notas Mus. La Plata, 8, pp.355-371.
- AHRENS, L.H. (1955). Oldest rocks exposed.
Geol. Soc. Amer. Spec. paper 62, pp.155-168.
- and TAYLOR, S.R. (1960). Spectrochemical analysis.
(2nd Edit). Addison-Wesley.
- ALDERMAN, A.R. and SKINNER, H.C.W. (1957). Dolomite sedimentation in Southeast of South Australia.
Amer. J. Sci., vol. 255, pp.561-567.
- ALEXANDROV, E.A. (1955). The origin of the Precambrian banded ironstones.
Econ. Geol., vol. 50, pp.459-468.
- ARUJA, E. (1945). An X-ray study of the crystal structure of antigorite.
Min. Mag., vol. 27, pp.65-74.
- ASWATHANARAYANA, U. (1956). Absolute ages of the Archaean Orogenic Cycles of India.
Amer. J. Sci., vol.254, pp.19-31.
- AUTL, W.U. (1959). Isotopic fractionation of sulphur in Geochemical Processes.
Researches in Geochemistry, John Wiley, NewYork. pp.241-259.
- BARGHOORN, E.S. (1957). Origin of life.
Geol. Soc. Amer. Mem.67. vol. 2, pp.75-86.
- BARTON, H.M. (1948). Electron microfossils.
Science, vol. 108, pp.745-6.
- BOYD, F.R. (1959). Hydrothermal investigations of amphiboles.
Researches in Geochemistry, John Wiley, NewYork. pp.377-396.
- BOYDELL, H.C. (1926). A discussion on Metasomatism and the Linear force of growing crystals.
Econ. Geol., vol. 21, pp.1-55.
- BRADLEY, W.F. (1940). The structural scheme of Attapulgitite.
Amer. Min., vol. 25, pp.405-440.
- BRUCE, E.L. (1945). Precambrian Iron Formations.
Geol. Soc. Amer. Bull., vol. 56, pp.589-602.

- CHALMERS, B. (1958). Growth of crystals of pure materials and of the solvents of solutions.
Growth and Perfection of Crystals. ed. by Doremos, Roberts and Turnbull. John Wiley, New York. pp.291-303.
- CHANNEY, F.C. (1952). Some aspects of the geochemistry of K, Rb, Cs and Tl in sediments.
Geol. Soc. Amer. Bull., vol. 63, p.1238.
- CHEPIL, W.S. (1957). Sedimentary characteristics of dust storms.
1. Sorting of wind-eroded soil material.
Amer. J. Sci., vol. 255, pp.12-22.
- CILLIERS, J.J.leR. and GENIS, J.H. (1961). Crocidolite asbestos in the Cape Province.
Special Economic Volume of Geol. Soc. of S.Afr. To be published.
- CLOUD, P.E. and BARNES, V.E. (1957). Early Ordovician sea in Central Texas.
Geol. Soc. Amer., Mem. 67, p.163-214.
- COLLINS, FARQUHAR and RUSSEL. (1954).
Geol. Soc. Amer. Bull., vol. 65, pp.1-22.
- CONWAY, E.J. (1943). The chemical evolution of the ocean.
Proc. Roy. Irish Acad., B.48, pp.161-212.
- CORRENS, C.W. (1950). Zur Geochemie der Diagenese.
1. Das verhalten von $\text{CaCO}_3 + \text{SiO}_2$.
Geochim. et Cosmochim Acta., vol. 21, pp.49-54.
- DANIELSSON, A. (1950). Das Calcit - Wollastonitgleichgewichte.
Geochim. et Cosmochim Acta., vol. 1, pp.55-69.
- DE VILLIERS, J. and SÖHNCE, P.G. (1959). The geology of the Richtersveld.
Geol. Surv. Union of S.Afr. Mem. 48.
- DORF, E. (1955). Major terrestrial floral changes.
Geol. Soc. Amer. Spec. Paper 62, p.577.
- DRYSDALL, A.R. and NEWTON, A.R. (1960). Blue Asbestos from Northern Rhodesia.
Amer. Min., vol. 45, pp.53-59.
- DUNN, J.A. (1935). Iron Ores of Singhbhum, India.
Econ. Geol., vol. 30, p.643.
- (1941). The origin of banded hematite ores in India.
Econ. Geol., vol. 36.

- DU PREEZ, J.W. (1944). The structural geology of the area east of Thabazimbi and the genesis of the associated iron ores. Stellenbosch Univ. Annals, vol. 22, Sec.A., pp.263-360.
- DU TOIT, A.L. (1905). Geological survey of portions of the divisions of Vryburg and Mafeking. Ann. Rept. Geol. Comm. for 1905, pp.205-258.
- (1907). Geological survey of portions of the divisions of Vryburg and Mafeking. Ann. Rept. Geol. Comm. for 1907, pp.123-157.
- (1945). The origin of the amphibole asbestos deposits of South Africa. Trans. geol. Soc. S.Afr., vol. 48, pp.161-206.
- (1954). Geology of South Africa, 3rd Edit., ed. by S.H. Haughton, Oliver and Boyd, London.
- DZHEDZALOV, A.T. (1958). The pattern of distribution of iron ore deposits in the Saksagainan region of Krivoy Rog. Bull. Acad. Sciences - U.S.S.R., Geol. Ser. No.2, pp.53-72.
- EMERSON, B.K. (1917). Geology of Massachusetts and Rhode Island. U.S. Geol. Surv. Bull. 597, pp.188-193.
- ERNST, W.G. (1959). Alkali amphiboles. Ann. Rept. of the Director Geophys. Lab., 1958-1959, pp.121-126. Reprinted from Carnegie Inst. Wash., Yearbook 58.
- (1960). The stability relations of magnesioriebeckite. Geochim. et Cosmochim Acta., vol. 19, pp.10-40.
- EUGSTER, H.P. (1959). Reduction and oxidation in metamorphism. Researches in Geochemistry, John Wiley, New York. pp.397-426.
- FENTON, C.L. and FENTON, M.A. (1957). Paleogeology of the Precambrian of Northwestern North America. Geol. Soc. Amer., Mem. 67, vol. 2, pp.103-116.
- FLASCHEN, F.F. and OSBORN, E.F. (1957). Studies of the system iron oxide - silica - water at low oxygen partial pressures. Econ. Geol., vol. 52, pp.923-943.
- FOCKEMA, R.A.P. (1953). Unusual occurrence of crocidolite on the farm Groot Aub 287, Rehoboth District, S.W.A. Trans. geol. Soc. S.Afr., vol. 56, pp.93-98.

- FORMAN, F.G. (1937). The Vampire Gorge crocidolite deposits, Hamersley Range, Northwest Division. Ann. Rept. of Geol. Surv. of Western Austr. (1937).
- GARROD, R.I. and RANN, C.S. (1952). Preliminary X-ray studies of crocidolite and amosite. Acta. Cryst., vol. 5, p.285.
- GILL, J.E. (1927). Origin of the Gunflint iron-bearing formation. Econ. Geol., vol. 22, pp.687-728.
- GOLDSMITH, J.R. (1959). Some aspects of the geochemistry of carbonates. Researches in Geochemistry, John Wiley, New York. pp.336-358.
- GOODWIN, A.M. (1956). Facies relations in the Gunflint iron formation. Econ. Geol., vol. 51, pp.565-595.
- GRIM, R.E. (1953). Clay mineralogy. McGraw-Hill Book Co. Inc. New York.
- GRUNER, J.W. (1922). Origin of sedimentary iron-formations; the Biwabik formation of the Mesabi Range. Econ. Geol., vol. 17, pp.407-460.
- (1926). Magnetite - Martite - Hematite. Econ. Geol., vol. 21, pp.375-393.
- (1936). The structure and chemical composition of greenalite. Amer. Min., vol. 21, pp.449-455.
- (1944a). The structure of stilpnomelane re-examined. Amer. Min., vol. 29, p.291-298.
- (1944b). The composition and structure of minnesotaite, a common iron silicate mineral in iron formations. Amer. Min., vol. 29, pp.363-372.
- GUILD, P.W. (1957). Geology and mineral resources of the Congonhas District, Minas Gerais, Brazil. Geol. Surv. Prof. Paper 290. U.S. Govt. Printing Office.
- HAGG, G. (1935). Die Kristallstruktur des magnetischen Ferrioxys, gamma - Fe_2O_3 . Zeit. Phys. Chemie, vol. 3^{29B}, pp.95-103.

- HALL, A.L. (1918). Asbestos in the Union of South Africa. 1st Edit.
Geol. Surv. Union of S.Afr., Mem. 12.
- (1930). Asbestos in the Union of South Africa. 2nd Edit.
Geol. Surv. Union of S.Afr., Mem. 12.
- (1918). The geology of the Barberton Gold Mining District
Geol. Surv. Union of S.Afr., Mem. 9.
- HAWLEY, J.E. (1926). An evaluation of the evidence of life in the Archean.
J. Geol. vol. 34, pp.441-461.
- HESS, H.H. (1946). Drowned ancient islands of the Pacific Basin.
Amer. J. Sci., vol. 244, pp.772-791.
- HEYSTEK, H. and SCHMIDT, E.R. (1953). The mineralogy of the attapulgitic - montmorillonite deposit in the Springbok Flats, Transvaal.
Trans. geol. Soc. S.Afr., vol. 56, pp.99-115.
- HUBER, N.K. and GARRELS, R.M. (1953). Relation of pH and oxidation-reduction potentials to sedimentary iron formations.
Econ. Geol., vol. 48.
- HUTTON, C.O. (1938). The stilpnomelane group of minerals.
Min. Mag., vol. 25, pp.172-206.
- JACK, R.L. (1921). Bundles and veins of crocidolite in altered magnesian limestones.
S.Austr. Dept. Mines, Mining Rev. No.33, pp.48-53 and No.34, p.62.
- JAMES, H.L. (1954). Sedimentary facies of iron formation.
Econ. Geol., vol. 49, pp.235-293.
- (1955). Zones of regional metamorphism in the Precambrian of northern Michigan.
Geol. Soc. Amer. Bull., vol. 66, pp.1455-1488.
- KELLER, W.D. (1936). Clay colloids as a cause of bedding in sedimentary rocks.
J. Geol., vol. 44, pp.52-59.
- KELLER, A. (1958). Morphology of crystalline polymers. Growth and Perfection of Crystals, ed. Doremus, Roberts and Turnbull, John Wiley, New York. pp.499-528.
- KEUNEN, P.H. (1950). Marine Geology.
John Wiley, New York.

- KRAUSKOPF, K.B. (1955). Factors controlling the concentrations of thirteen rare metals in sea water.
Geochim. et Cosmochim Acta., vol. 9, pp.1-32.
- (1956). Dissolution and precipitation of silica at low temperatures.
Geochim. et Cosmochim Acta., vol. 10, pp.1-26.
- KRUMBEIN, W.C. and GARRELS, R.M. (1952). Origin and classification of chemical sediments in terms of pH and oxidation-reduction potentials.
J. Geol., vol. 60, pp.1-33.
- KUIPER, G.P. (editor). (1952). The atmospheres of the earth and planets. 2nd Edit.
Univer. of Chicago Press, Chicago.
- LIEBENBERG, W.R. (1955). The occurrence and origin of Gold and Radioactive Minerals in the Witwatersrand System, the Dominion Reef, the Ventersdorp Contact Reef and the Black Reef.
Trans. geol. Soc. S.Afr., vol. 58, pp.101-227.
- LOVERING, T.S. (1923). The leaching of iron protores, solution and precipitation of iron and silica in cold water.
Econ. Geol., vol. 18.
- MACGREGOR, A.M. (1927). The problem of the Precambrian atmosphere.
S.Afr. J. of Sci., vol. 24, pp.155-172.
- (1941). A Precambrian algal limestone in Southern Rhodesia.
Trans. geol. Soc. S.Afr., vol. 43, pp.9-16.
- (1951). Some milestones in the Precambrian of Southern Rhodesia. (Presidential address).
Trans. geol. Soc. S.Afr., vol. 54, pp.xxvii - lxxi.
- MAGNUSSON, N.H. (1936). The evolution of the lower Archaean rocks in central Sweden, and their iron, manganese and sulphide ores.
Geol. Soc. London. Quart. J., vol. 92, pp.332-359.
- MARSHALL, C.E. and CALDWELL, O.G. (1947). The colloid chemistry of the clay mineral - attapulgate.
J. Phys. Colloid Chem., vol. 51, pp.311-320.
- MASON, B. (1958). Principles of Geochemistry. 2nd Edit.
John Wiley and Sons, New York.

- MCKERROW, W.S., TAYLOR, S.R., AHRENS, L.H. and BLACKBURN, A.L. (1956). Occurrence of Caesium in fossils. Nature, vol. 178, p.204.
- MERCY, E.L.P. (1956). Accuracy and precision of rapid methods of silicate analysis. Geochim. et Cosmochim Acta., vol. 9.
- MILES, K.R. (1942). The blue asbestos bearing banded iron formations of the Hamersley Ranges, Western Australia. West. Austr. Geol. Surv. Bull. 100, pt.1.
- (1946). Metamorphism of the jasper bars of Western Australia. Geol. Soc. Lond. Quart. J., vol. 102.
- MILLER, S.L. (1953). A production of amino acids under possible primitive earth conditions. Science, vol. 117, pp.528-529.
- MILTON, C. and EUGSTER, H.P. (1959). Mineral assemblages of the Green River Formation. Researches in Geochemistry, John Wiley, New York, pp.118-150.
- MIYASHIRO, A. (1957). The chemistry, optics and genesis of the alkali amphiboles. J. Faculty of Sci., Univ. of Tokyo, Sect.2, vol. 11, pt.1.
- and BANNO, S. (1958). The nature of glaucophanitic metamorphism. Amer. J. Sci., vol. 256.
- MOORE, E.S. and MAYNARD, J.E. (1929). The solution, transportation and deposition of iron and silica. Econ. Geol., vol. 24, p.272.
- NICOLAYSEN, L.O., et al. (1958). New measurements relating to the absolute age of the Transvaal System and the Bushveld Igneous Complex. Trans. geol. Soc. S.Afr., vol. 61, pp.137-163.
- OFTEDAHL, C. (1958). A theory of exhalative sedimentary ores. Skriftryck ur Geologiska Föreningens i Stockholm Förhandlingar, Bd 80, H.1.
- PAULING, L. (1930). Structure of talc. Proc. Nat. Acad. Sc. (Wash).

- PEACOCK, M.A. (1928). The nature and origin of the amphibole asbestos of South Africa.
Amer. Min., vol. 13, pp.241-285.
- P'EI-CHEN. TING. (1960). A preliminary study of the magnetite deposit at Chien-p'ing, Hopei province.
Internat. Geol. Rev., vol. 2, pp.1-7.
- PETTIJOHN, F.J. (1957). Sedimentary Rocks. 2nd Edit.
Harper and Brothers, New York.
- RANKAMA, K. (1955). Geologic evidence of chemical composition of the Precambrian atmosphere.
Geol. Soc. Amer. Spec. paper 62, pp.651-664.
- and SAHAMA, T.G. (1950). Geochemistry.
Univ. Chicago Press, Chicago.
- RICHARZ, S. (1927). Grunerite rocks of the Lake Superior Region and their origin.
J. Geol., vol. 35, pp.690-707.
- ROGERS, A.W. (1906). Geological survey of parts of Hay and Prieska.
Ann. Rept. Geol. Comm. for 1905, pp.141-204.
- (1907). Geological survey of parts of Bechuanaland and Griqualand West.
Ann. Rept. Geol. Comm. for 1906, pp.19-49.
- and DU TOIT, A.L. (1908). Report on the geology of parts of Prieska, Hay, Britstown, Carnarvon and Victoria West.
Ann. Rept. Geol. Comm. for 1907, pp.9-109.
- RUBEY, W.W. (1951). The geologic history of sea water. An attempt to state the problem.
Geol. Soc. Amer. Bull., vol. 62, pp.1111-1147.
- (1955). Development of the hydrosphere and atmosphere with special reference to the probable composition of the early atmosphere.
Geol. Soc. Amer., Spec. paper 62, pp.631-650.
- SAKAMOTO, T. (1950). The origin of Precambrian banded iron-ores.
Amer. J. Sci., vol. 248, pp.449-474.
- SAULL, V.A. (1955). Chemical energy and metamorphism.
Geochim. et Cosmochim Acta., vol. 8, pp.86-106.

- SHAPIRO, L. and BRANNOCK, W.W. (1956). Rapid analysis of silicate rocks.
U.S. Geol. Surv. Bull. 1036-C. Revised from Circular 165.
- SMITH, F.G. and CAVANAGH, P.E. (1958). Compilation of data on iron-bearing minerals with special reference to taconite. "Iron ore minerals", Ontario Research Foundation.
- SPENCER, E. and PERCIVAL, F.G. (1952). The structure and origin of the banded hematite jaspers of Singhbhum, India.
Econ. Geol., vol. 47, pp.365-383.
- SVITALSKY, N. (1937). Krivoy Rog and iron ores of this district. 17th Internat. Geol. Cong., Guide Book of Southern Excursion - the Ukranian S.S.R. pp.51-77.
- TABER, S. (1916). The growth of crystals under external pressure.
Amer. J. Sci., vol. 41, pp.532-556.
- (1917). The genesis of asbestos and asbestiform minerals.
Trans. Amer. Inst. Min. Eng., vol. 57, pp.62-87.
- (1924). The origin of veins of fibrous minerals.
Econ. Geol., vol. 19, pp.475-486.
- (1926). Metasomatism and the pressure of growing crystals. Discussion.
Econ. Geol., vol. 21, pp.717-727.
- TEGENGREN, F.R. (1921). The Iron ores and Iron Industry of China.
Mem. Geol. Surv. China, Ser. A., No.2. pts. 1 and 2.
- THIEL, G.A. (1927). The relative effectiveness of bacteria as agents of chemical denudation.
J. Geol., vol. 35, p.647.
- THIESMEYER, L.R. (1937). Vein quartz pseudomorphs of cross-fibre asbestos in Virginia.
Amer. Min., vol. 22, pp.701-719.
- THODE, H.G., MACNAMARA, J. and FLEMING, W.H. (1953). Sulphur fractionation in nature and geological and biochemical time scales.
Geochim. et Cosmochim Acta., vol. 3, pp.235-243.
- TILTON, G.R. and DAVIS, G.L. (1959). Geochronology. Researches in Geochemistry, John Wiley, New York, pp.190-216.

- TWENHOFEL, W.H. (1932). Principles of Sedimentation.
McGraw-Hill, New York.
- TYLER, S.A. and TWENHOFEL, W.H. (1952). Sedimentation and stratigraphy of the Huronian of Upper Michigan.
Amer. J. Sci., vol. 250, p.1-27 and 118-151.
- UREY, H.C. (1951). The origin and development of the earth and other terrestrial planets.
Geochim. et Cosmochim Acta., vol. 1, pp.209-277.
- (1952). The origin and development of the earth and other terrestrial planets - a correction.
Geochim. et Cosmochim Acta., vol. 2.
- URIE, J.G. (1958). The geology of the Bomvu Ridge iron deposits in northwestern Swaziland.
Unpublished M.Sc. thesis, Univ. of Witwatersrand.
- VAN HISE, C.R. and LEITH, C.K. (1911). Geology of the Lake Superior Region.
U.S. Geol. Surv. Monograph 52.
- VERMAAS, F.H.S. (1952). The amphibole asbestos of South Africa.
Trans. geol. Soc. S.Afr., vol. 55, pp.199-229.
- WAGNER, P.A. (1928). The iron deposits of South Africa.
Union of S.Afr. Geol. Surv., Mem.26. pt.2.
- WALD, G. (1954). The origin of life.
Scientific American, vol. 191, no.2, pp.45-53.
- WARREN, C.H. and PALACHE, C. (1911). The pegmatites of the riebeckite-aegerite granite at Quincy, Mass., U.S.A.; their structure, minerals and origin.
Proc. Amer. Acad. Arts, Sci., vol. 47, pp.125-168.
- WHITTAKER, E.J.W. (1949). The structure of Bolivian Crocidolite.
Acta Cryst., vol. 2, pp.312-317.
- (1960). The crystal chemistry of amphiboles.
Acta Cryst., vol. 13, pp.291-298.
- WIEBOLS, J.H. (1955). A suggested glacial origin for the Witwatersrand conglomerates.
Trans. geol. Soc. S.Afr., vol. 58, pp.367-382.

- WILLEMSE, J. (1959). The "Floor" of the Bushveld Igneous Complex and its relationships, with special reference to the Eastern Transvaal. (Presidential Address).
Trans. geol. Soc. S.Afr., vol. 62, pp.xxi-Lxxx.
- WILSON, J.T. (1959). Geophysics and continental growth.
American Scientist, vol. 47, pp.1-24.
- WINCHELL, A.W. (1951). Elements of optical mineralogy, 4th Edit, Part II.
John Wiley, New York.
- WYMOND, A.P. and WILSON, R.B. (1951). An occurrence of crocidolite near Robertstown, South Australia.
Trans. Roy. Soc. S.Austr., vol. 74, pp.44-48.
- YOUNG, R.B. (1932). The occurrence of stromatolitic or algal limestones in the Campbell Rand Series, Griquatown West.
Trans. geol. Soc. S.Afr., vol. 35, pp.29-36.
- (1933). Conditions of deposition of the Dolomite Series.
Trans. geol. Soc. S.Afr., vol. 36, pp.121-135.
- (1934). A comparison of certain stromatolitic rocks in the Dolomite Series of South Africa with modern algal sediments in the Bahamas.
Trans. geol. Soc. S.Afr., vol. 37, pp.153-162.
- (1945). Nodular bodies in the dolomite series.
Trans. geol. Soc. S.Afr., vol. 48, pp.43-48.

M.G.D. - Kinross,
P.O. Box 1,
Evander, Tvl.

APPENDIX NO.1

Details of chemical and spectrographic analyses

(a) Preparation of samples

The selected samples were crushed to less than 100 mesh in a percussion mortar, the final plus 100 mesh fragments being ground down in an agate mortar. Particular care was taken not to crush or grind too harshly in order to prevent oxidation of FeO. Great difficulty was experienced in getting the asbestos-bearing samples fine enough. The crocidolite specimens were not ground, hand-picked fibres being cut as fine as possible with a pair of steel scissors instead. Samples for spectrographic analysis were treated as above, except that crushing was taken to -120 mesh and that bolting cloth held in polythene formers were used as sieves. Samples of crocidolite for spectro-chemical analysis were first heated to 400°C., at which temperature the fibre loses its tensile strength, cooled and then ground in an agate mortar. Preliminary tests showed that no loss of alkali elements resulted from such treatment.

All samples were dried at 110°C. before analysis. Roughly aliquot amounts of the samples were placed in numbered glass specimen tubes, dried for a minimum of 2 hours, cooled in a dessicator, and corked with rubber stoppers. Before weighing the tubes were allowed to stand in the balance case for 20 minutes and then the sample aliquots were weighed by difference.

(b) Chemical Analyses

The scheme of rapid silicate analysis of Shapiro and Brannock (1956), as modified by Mercy (1956), was followed. Further modifications, in part as suggested by C.J. Liebenberg (unpublished thesis), were introduced because of the iron-rich nature of the samples.

In the colourimetric determinations a Hilger Spekker absorptiometer was used. Working standards were prepared from Analar chemicals and subsequently corrected against the standards G1 and W1.

Potassium and sodium were determined on an Eel flame-photometer with working standards prepared and corrected in the same way as above.

Six aliquot amounts of each sample were used to determine the oxides in the following way:-

Solution A: 2 aliquots of approximately 50 mg. each. Silica determined colourimetrically by reduced molybdate method.

Solution B: 1 aliquot of approximately 500 mg. digested in HF + H₂SO₄ and made up to 250 ml.

Alkalis: 25 ml. aliquot of solution B made up to 100 ml. after precipitation of R₂O₃. Determined on flame-photometer.

R₂O₃: 50 ml. aliquot. Determined gravimetrically after oxidation of iron.

CaO and MgO: Filtrate of R₂O₃ determination evaporated to dryness and ammonium salts fumed off with concentrated HNO₃. Determined by titration with E.D.T.A. using Murexide indicator in green light for CaO and Eriochrome Black T for MgO. Great difficulty was experienced in getting a clear endpoint for MgO, due probably to the presence of some interfering element. The MgO figures were checked by spectrographic analysis.

MnO: 25 ml. aliquot of solution B oxidised with potassium periodate and determined colourimetrically as permanganate.

P₂O₅: 25 ml. aliquot of solution B determined colourimetrically as vanado-molybdate.

TiO₂: 25 ml. aliquot of solution B determined colourimetrically with hydrogen peroxide.

Fe₂O₃: 10 ml. aliquot of solution B diluted to 2,500 ml.
Determined colourimetrically with ammoniacal thioglycollic acid.

Due to the high dilution required this determination was considered inaccurate and Fe₂O₃ content was corrected by difference in R₂O₃ after subtraction of FeO (as Fe₂O₃), Al₂O₃, MnO and TiO₂.

Al₂O₃: determined spectrographically.

FeO: 1 aliquot of approximately 500 mg. Rapidly digested in HF, dissolved in boric acid solution and titrated with potassium dichromate against diphenylamine sulphonate as an internal indicator. Potassium dichromate was standardised against magnetite standards, EG 4355 and EG 5051.

H₂O: 1 aliquot of approximately 500 mg. mixed in lead chromate carrier was heated in a small test-tube. Water absorbed in weighed filterpaper.

CO₂: 1 aliquot of approximately 500 mg. boiled in HCl. Carbon dioxide absorbed in suitably guarded, weighed, soda-lime (carbisorb) tubes.

In one sample (G16T) carbon was determined by digesting an aliquot in H.F., diluting and filtering off the insoluble carbon on an asbestos (chrysotile) mat in a weighed gooch crucible.

Samples analysed by these methods were:-

G34D, G22M, G97P, ET26, G90P, G89P, G21P, G7P, G26P, G7M, G16T.

(c) Spectrographic analyses

1. Determination of the alkali elements

These were determined using the general method described by Ahrens and Taylor (1960, Chapter 13).

The following conditions were common to all determinations: Spectrograph: Hilger large quartz and glass prism instrument. Glass optics - wavelength range 4600-9600. Current 5 amp. short circuit. 7 step sector (2 : 1 ratio). Wedge 11. Samples were burnt to end of alkali element distillation. Anode excitation.

For samples G21P, G89P, G90P and G16T, which had a high K content, electrodes (anodes) with an internal diameter of $3/32$ " and a depth of 5 mm. were used (National Carbon Co. regular grade). Ship carbon (5 mm.) cathodes were used.

For samples G7P, G27P, G97P, G7M, G22M and G34D, which had a low K content, larger anodes ($1/8$ " x 5 mm) were used. Ship carbon (5 mm.) cathodes were used.

Slit width was 10 for all samples. Kodak IN plates were used. Na 5688 was used as the internal standard line and Rb 7800, 7947, Li 6707, Cs 8521 were read using a Hilger non-recording microphotometer. Background corrections were made in a few cases for Rb 7800. G-1 and W-1 were used as primary standards and a set of standards for Cs was prepared from a lepidolite containing 1400 ppm. Cs, and a feldspar with no detectable Cs.

To establish K/Rb/Cs ratios in samples G16T, G6P, G68P, similar conditions were used except that Kodak IL plates were substituted and anodes were $3/32$ " x 2.5 mm. K 6939, Rb 7947 and Cs 8521 were read. The standards were G-1, Pen 12 and Pen 13. Pen 12 and Pen 13 are alkali feldspars kindly supplied by Mr. P. Kolbe-Falkenhain.

The problem of determining Na in crocidolite samples was simplified because of their low K content. No salts of the alkali elements were suitable for adding to serve as internal standards, either because the available ones were hygroscopic, or contained too much Na. The U.S.B.S. plastic clay (No.98) contains 3.17% K_2O and 0.2% Na_2O . 2 parts of this were added to 1 part of the sample and K served as the internal standard. Conditions were as before, except that the anodes were 1/8" x 2.5 mm. Kodak IN plates were used. Na 5688 and K 6939 were read.

Na was determined in the following samples by this method:-
G8P, G40P, G45P, G48P, G56P, G69P, G71P, G88P, G97P, G34D, G36D,
G42D, G48D, G2M, G16M, G19T, G22T, G23T.

Duplicates were run in for all the samples and agreement was within 10% of the average in all cases, and frequently within 5%.

2. Involatile elements

These elements were determined by the general procedure outlined by Ahrens and Taylor (1960, Chapter 13), for the determination of the involatile elements using Pd as an internal standard. One part of sample was mixed with five parts of a carbon powder which contained 10% by weight of $(NH_3)_4Pd \cdot (NO_3)_2$. Anodes were 3/32" x 2.5 mm. and were cut from National Carbon Co. special spectroscopic graphite 3/16" electrodes (Cat. No.3863). Cathodes were 1/8" National Carbon Co. special spectroscopic carbon (Cat. No.L 3803). Samples were burnt to completion using 3 amp. d.c. short circuit (anode excitation). A seven step sector (ratio 2 : 1) was used. Wedge 11. Ilford Zenith plates. Two wavelength ranges were used:-
(i) Quartz optics 2470-3560. In this wavelength range the slit width was 10. (ii) Glass optics 3800-5300, slit width 5. In both cases an F 958 lens was focused on the slit. The standards used were G-1,

W-1, and two magnetite standards EG 4355, EG 5051 kindly supplied by Dr. E.A. Vincent.

Samples analysed by these methods were:-
G89P, G90P, G21P, G16T, G7M, G27P, G7P, G97P, G22M, and G34D.

For the determination of trace elements in magnetites, the wavelength range 3800-5300 was covered. A double lens system consisting of an F 958 lens, focused on the slit, and an F 1036 focused on the collimating lens, was used. The other conditions were as before mentioned, except that Kodak 103-0 plates were used. The standards were EG 4355 and EG 5051.

Samples analysed by this method were:-
HV16/354, G16T, G26P, G29P, G18T, G4P, G23T.

Duplicates were run for all the samples and agreement was within 10% of the average in all cases, and frequently within 5%.

APPENDIX NO.2

Experiments at elevated temperatures and pressures

Two experiments were carried out in a steel bomb with a 15 ml. capacity. These were:-

1. Alternating layers of powdered mass-fibre riebeckite (Spec.G97P), carbonate and chert (Spec.G7P) and a magnetic iron hydroxide made by co-precipitating equal volumes of molar solutions of ferrous sulphate and ferric chloride in dilute ammonium hydroxide. The materials were contained in a pyrex glass tube, cut to fit the reaction chamber of the bomb, and were packed to a 60% fill in the wet state by centrifuging a slurry at 4000 revs. per minute and drawing off the supernatant water.

The bomb was sealed and heated in a thermostatically controlled furnace at a temperature of 350°C. for eight days and then cooled at the rate of 50°C. per day for seven days.

The materials were examined microscopically but no reaction, apart from the formation of cavities within the packed mass, took place. No signs of recrystallisation of the material could be seen.

2. Alternating layers of stilpnomelane (Spec.G89P), magnetite (Spec. G26P), minnesotaite-chert (Spec.G29P), and syrupy sodium silicate were packed as above. The bomb was heated at 450°C. for 30 days and then cooled in air for two days.

It was found that the whole mass had become homogenised and was pale blue in colour. The prominent dark green colour of the stilpnomelane had completely disappeared.

In the matrix, slender 1 mm. long needles with pinacoidal ends of a colourless to faintly brownish-blue coloured mineral, identified as acmite, was found. This acmite had the following optical properties:- α to $c = 3^\circ - 5^\circ$; $\alpha = 1.765$ and β or $\gamma = 1.818$. Winchell (1951, p.416) gives refractive indices of $\alpha = 1.762$ and $\gamma = 1.814$ for an acmite with 32.0% Fe_2O_3 .

The pale bluish groundmass has an aggregate refractive index of 1.690.

It was concluded that acmite formed by the reaction of stilpnomelane and probably minnesotaite with sodium silicate. Insufficient magnetite was present to keep the reaction completely within the riebeckite stability field. It is thought that the pale blue colour of the groundmass may be due to the presence of sub-microscopic riebeckite crystals, but without X-ray facilities this could not be checked.

APPENDIX NO.3

Experiments on the crystallisation of copper sulphate

A number of experiments on the growth of copper sulphate crystals in viscous media were carried out. It was attempted to simulate the different types of riebeckite crystals and thereby try to arrive at some idea of the conditions of crystallisation of the riebeckite.

Boiling, saturated solutions of copper sulphate were mixed with different amounts of gelatine, re-heated and dropped on a warmed microscope slide. The crystallisation of the copper sulphate was then observed as the solution cooled. Some of the results are shown in Plate XXVII. In a medium of approximately 1 gm. gelatine per ml. of solution long thin needles of copper sulphate crystallised (Plate XXVIIA). Crystallisation commenced before the gelatine solution set. In a second experiment with this medium a cold needle was inserted in the drop to provide an initiating surface. Copper sulphate grew from this surface into the medium in branching and diverging, but on the whole, sub-parallel, dendrites (Plate XXVII B). At a gelatine concentration of approximately 2 gms/ml. the resultant gel set rapidly and copper sulphate crystallised rapidly as masses of short, stubby needles (Plate XXVII C).

At a gelatine concentration of more than 3 gms/ml. the gel set just below boiling temperature and the crystallisation of copper sulphate was much retarded. The slide was left overnight and the next morning it was found that fibrous spherulites of copper sulphate (Plate IVC, p.19) had crystallised.

The conclusions drawn from these experiments are that the riebeckite must have crystallised in a viscous medium and that crocidolite could not have attained its perfectly parallel orientation by

PLATE XXVII

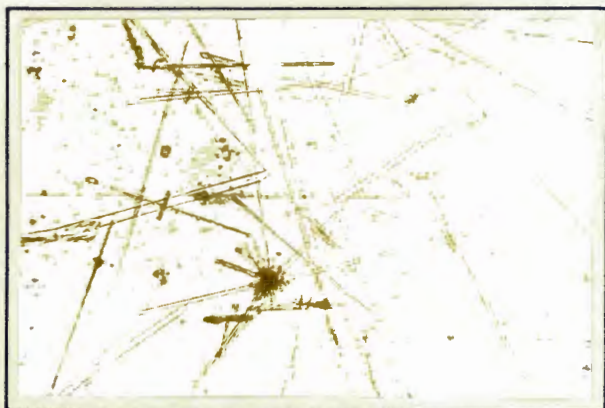

A. COPPER SULPHATE FIBRES

Ordinary light, X 396 diameters.

Note similarity to fibrous riebeckite in Plate XIVC, p.59.



B. COPPER SULPHATE DENDRITES GROWING FROM INITIATING SURFACE

Ordinary light, X 138 diameters.

Note divergence of fibres from the perpendicular similar to riebeckite in Plate XIVC, p.59.

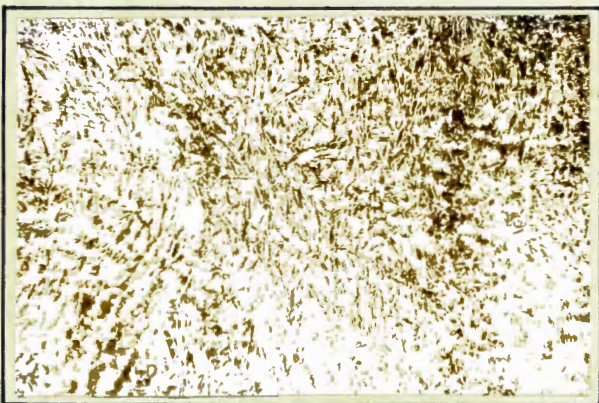

C. MASS-FIBRE COPPER SULPHATE

Ordinary light. X 396 diameters.

Note partly formed spherulites similar to tufts of riebeckite in Plate IIIA, p.16.

growing away from an initiating surface of magnetite into a medium of mass-fibre riebeckite.

Taber's (1924) porous pot experiment was repeated. Although no cross-fibre veins developed in the walls of the pot, numerous clumps or bundles of perfectly parallel copper sulphate fibres grew away from the walls. Each of these bundles had a thin capping of material derived from the outer surface of the pot. They showed the typical banded reflections (chatoyancy) exhibited by crocidolite and especially by "tiger's eye". Cross-fibre crystals also grew between the pot and the upturned edge of a waxed cardboard evaporation cover. The pressure exerted by the growth of these crystals was sufficient to "dish" the cardboard cover and lift the whole pot through a vertical distance of approximately $\frac{1}{2}$ cm., as illustrated in Fig.13.

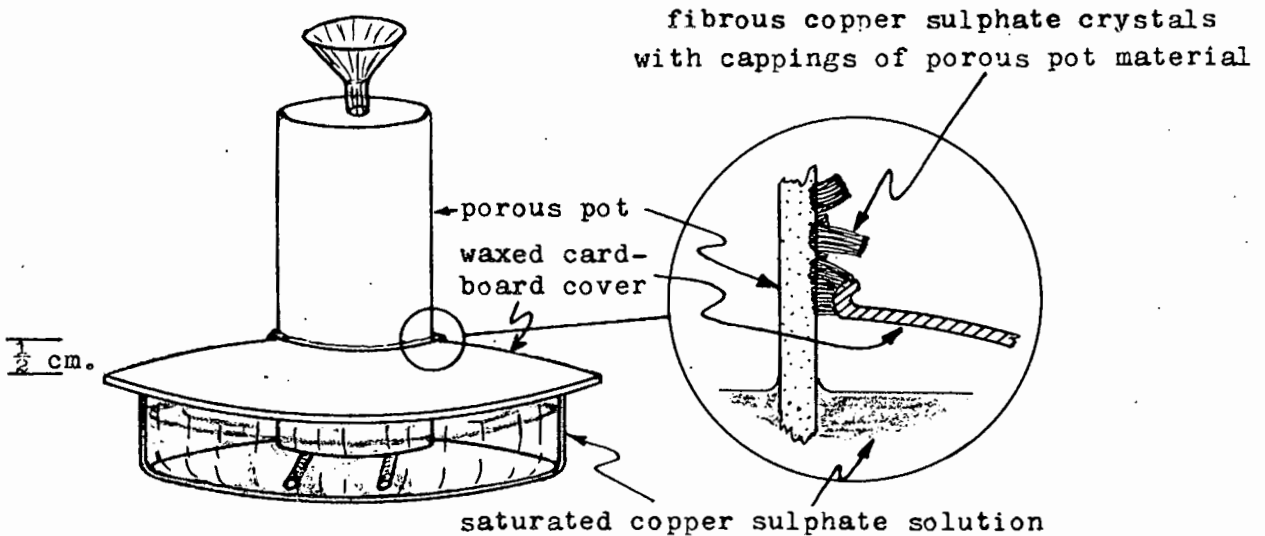

Fig.13. The growth of copper sulphate through a porous pot.

From this experiment it was concluded that any mineral will grow in a fibrous state provided it is fed through micro-capillaries at a surface of crystallisation, and that such fibrous crystals exert a definite and quite considerable pressure during growth.

THE GENESIS OF THE BLUE AMPHIBOLE ASBESTOS
OF THE UNION OF SOUTH AFRICA

by J.H.GENIS.

SUMMARY

The blue amphibole asbestos, crocidolite, which occurs as interbedded seams in banded ironstones of the Lower Griquatown Stage of the Transvaal System in the Northern Cape Province, is the finely fibrous form of the soda-amphibole riebeckite. Despite the widespread occurrence of the Precambrian type of banded ironstones, crocidolite is a mineral of rare occurrence and is only developed to a relatively minor extent in South Africa, Western Australia and Central China.

The composition, structure and properties of riebeckite in general and of crocidolite in particular are discussed and four new chemical analyses are given. Particular attention is paid to the mode of occurrence of fibrous riebeckite and it is suggested that the name "crocidolite" be reserved for the asbestiform riebeckite which occurs interbedded with banded ironstones.

The general geology, lithology and mineralogy of Precambrian banded ironstones are described and their distribution in space and time is discussed. It is found that no banded ironstones are known to be younger than 1000 million years. This fact is related to special conditions of atmosphere, surface temperature and biological development which existed during the so-called Primitive Period of the Precambrian, a period which lasted from approximately 3000 million years to 1000 million years ago.

The banded ironstones of the Transvaal System are described in some detail and seven new chemical analyses as well as trace element data are given.

The genesis of banded ironstones is discussed at some length and particular attention is paid to the authigenesis of riebeckite. It is concluded that banded ironstones were deposited in seasonally fluctuating, typically "non-aggressive", fresh to brackish water lakes which were fed by sluggish, mature rivers. The solutions of iron and silica, alkaline earths and clay colloids carried by these rivers were derived from basic igneous rocks by chemical weathering in a tropical, monsoon-type climate. Recognisable detrital material is virtually absent from the banded ironstones of the Transvaal System, but it is thought that the stilpnomelane layers are aeolian deposits and that their composition gives some indication of the material which remained behind as "lateritic" soils in the source area. It is suggested that both crocidolite and riebeckite were formed by the low temperature dehydration, in situ, of an ordered precursor which could have been a clay mineral similar in structure to attapulgite, but containing ferrous and ferric ions in the octahedral layer. This clay mineral acquired sodium by cation exchange during dry periods when the depositional lakes were enriched in sodium.

It is found that the actual formation of crocidolite is completely unrelated to dynamic stress. It formed only where layers of proto-riebeckite were in close contact or traversed by magnetite layers. It grew by the diffusion of proto-riebeckite through the magnetite layers, its transformation to riebeckite during its passage, and final addition to fibre growth points in contact with the magnetite layer. This process was initiated by slight temperature gradients in the magnetite layers and was propagated by a type of thermal autocatalysis. The temperature gradients in the magnetite layers resulted from their superior heat conductivity combined with differences in depth of burial of the strata. Economic deposits

of crocidolite formed where a sufficient number of layers of proto-riebeckite were in contact with magnetite layers which maintained or repeatedly attained the requisite temperature levels. The super-imposed economic deposits of the Kuruman area, which appear to be related to folding, are due to an early period of folding, possibly even slumping during deposition, which took place prior to the formation of crocidolite and caused the thickening of the proto-riebeckite layers in the crests and troughs of folds by plastic flow from the flanks.

It is thought that amosite, the fibrous form of grunerite, which occurs in the Transvaal, was formed in the same manner as riebeckite, but from a parent material which lacked sodium. The close association of amosite with riebeckite and the occurrence of grunerite in place of minnesotaite suggest a common parent material, ferri-attapulgitic, for all three minerals. Whether minnesotaite or grunerite formed from the ferri-attapulgitic depended on the grade of metamorphism, while riebeckite only formed from ferri-attapulgitic which had incorporated sodium. The doublet seams of the Malips Drift area are thus thought to derive from beds of ferri-attapulgitic which decreased rapidly in sodium content either upwards or downwards.

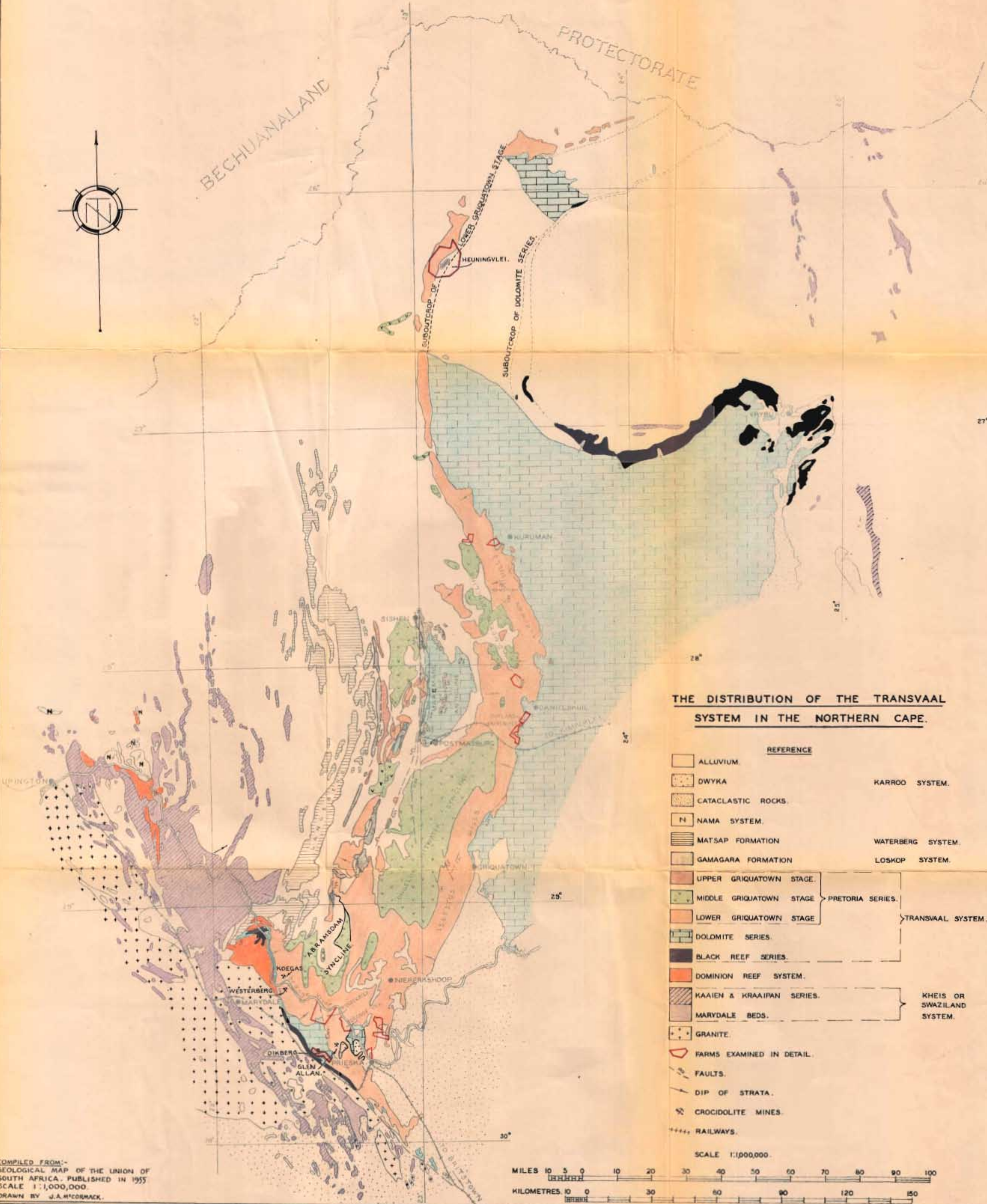

BECHUANALAND

PROTECTORATE

THE DISTRIBUTION OF THE TRANSSVAAL SYSTEM IN THE NORTHERN CAPE.

- REFERENCE**
- ALLUVIUM.
 - DWYKA
 - CATACLASTIC ROCKS.
 - NAMA SYSTEM.
 - MATSAP FORMATION
 - GAMAGARA FORMATION
 - UPPER GRIQUATOWN STAGE.
 - MIDDLE GRIQUATOWN STAGE
 - LOWER GRIQUATOWN STAGE
 - DOLMITE SERIES.
 - BLACK REEF SERIES.
 - DOMINION REEF SYSTEM.
 - KAAIEN & KRAAIPAN SERIES.
 - MARYDALE BEDS.
 - GRANITE.
 - FARMS EXAMINED IN DETAIL.
 - FAULTS.
 - DIP OF STRATA.
 - CROCIDOLITE MINES.
 - RAILWAYS.
- KARROO SYSTEM.**
- WATERBERG SYSTEM.**
- LOSKOP SYSTEM.**
- PRETORIA SERIES.**
- TRANSSVAAL SYSTEM.**
- KHEIS OR SWAZILAND SYSTEM.**

COMPILED FROM:-
GEOLOGICAL MAP OF THE UNION OF
SOUTH AFRICA. PUBLISHED IN 1955
SCALE 1:1,000,000.
DRAWN BY J.A. McCORMACK.

