

UNIVERSITY OF CAPE TOWN



IMPROVING BUFFALO CITY'S SUB-TRANSMISSION RELIABILITY

AUTHOR: JOSEPH KINGSLEY ATTOM BENTIL

STUDENT NUMBER: BNTJOS002

SUPERVISOR: PROFESSOR CT GAUNT

DATE: DECEMBER 2016

A Research Dissertation in Fulfilment with the Requirements of the Degree  
Master of Science: Electrical Engineering in The Department of Electrical  
Engineering of The University of Cape Town.

The copyright of this thesis vests in the author. No quotation from it or information derived from it is to be published without full acknowledgement of the source. The thesis is to be used for private study or non-commercial research purposes only.

Published by the University of Cape Town (UCT) in terms of the non-exclusive license granted to UCT by the author.

## **ABSTRACT**

Several experiences of sudden large scale disruptions in electrical service deeply impacted both social stability and economic development in affected communities and caused lower levels of reliability performance. The prevention of such catastrophic incidents poses huge challenges for reliability study and operational practices in Buffalo City's sub-transmission network. Primarily investigations on the field shows, aging infrastructure, relay failures and reactive maintenance practice is eminent. Inspired by these challenges, this dissertation proposes an analysis of the critical transition in sub-transmission network from a lower level of reliability to an economically and acceptable level of reliability. The transition of the operational "stress" and its large scale of power interruptions are studied. The transition of the existing sub-transmission to the alternative sub-transmission models has been presented. The analysis of load flow and fault level calculations identifies the loading trends critical to cause operational "pressure" of unplanned interruptions. The results in this research work had to discover the most appropriate resolutions to aging equipment, reactive maintenance and protection systems. The DIgSILENT Power Factory simulates and quantifies the results of the problems that could occur in the sub-transmission network in the immediate future. Measures to mitigate any occurrence which might cause more prone to a catastrophic blackout are presented. The proposed corrective measures of upkeep aging infrastructure, relay responsiveness and planned preventative maintenance have been recommended. The development of these corrective measures and the proposed network model is the key to reaching higher levels of reliability performance in the energy supply that communities require in Buffalo City Metropolitan Municipality.

## **ACKNOWLEDGEMENTS**

*In all thy ways acknowledge Him, and He shall direct thy paths (Proverbs 3:6).*

I would like to express my special appreciation to Professor CT Gaunt (University of Cape Town: Electrical Engineering Department), for outstanding supervision, support, encouragement, and for exercising maximum level of patience throughout this dissertation.

I would further render my sincere thanks to my family: my wife Elizabeth, who exercised maximum level of patience and support for this project; my lovely children Enoch, Grace, Joseph, Joshua, and Caleb who supported the project.

My Employer, Buffalo City Metropolitan Municipality is well acknowledged for the part played in sponsoring my studies.

## **DEDICATION**

*I dedicate this dissertation to the following persons:*

- The Almighty God, who loved, and cared, and have given me the strength, persistence and wisdom all these years and given me the opportunity to follow this course.
- My wife Elizabeth; who was behind the scene encouraging me to continue this dissertation until its completion.
- My late father whom, even though he is uneducated, found it indispensable to give me education.

## **TABLE OF CONTENTS**

ABSTRACT	I
ACKNOWLEDGEMENTS	II
DEDICATION	III
TABLE OF CONTENTS	IV
LIST OF FIGURES	VIII
LIST OF TABLES	X
LIST OF ABBREVIATIONS	XII
<b>CHAPTER 1: INTRODUCTION</b>	<b>1</b>
1.1 Problems of loss of supply	1
1.2 Unreliability	2
1.3 Causes of power interruptions	2
1.4 Possibilities for improvement	5
1.5 Problem statement	6
1.6 Research questions	6
1.7 Methodology	6
1.8 Organisation of the dissertation	7
<b>CHAPTER 2: LITERATURE REVIEW</b>	<b>9</b>
2.1 Introduction	9
2.2 Aging power system infrastructure	9
2.2.1 Equipment aging	11
2.2.2 Concept of power system equipment life time	12
2.2.3 Reliability issues with aging equipment	12
2.3 Non-responsiveness of protective devices (relay failure)	14

2.3.1 Introduction	14
2.3.2 Reliability of protection system	15
2.3.3 Failure modes of protection system	16
2.3.4 Causes of relay misoperation	17
2.3.5 Reliability modelling of protection systems	18
2.3.5.1 General reliability model	18
2.3.5.2 Detailed reliability model of directional overcurrent protection system	19
2.4 Power system maintenance	22
2.4.1 Optimizing equipment lifecycle	22
2.4.2 Maintenance philosophy	24
2.4.3 Maintenance strategy	25
2.5 Prevention and mitigation of blackouts	27
2.5.1 Improvements on traditional relay principles	27
2.6 Cost of reliability	30
2.6.1 Customer interruption cost analysis	30
2.6.2 Reliability versus cost	32
2.6.3 Cost-effectiveness	33
2.6.4 Cost-benefit analysis	33
2.7 Summary	34
2.7.1 Aging infrastructure equipment	35
2.7.2 Non-responsiveness protective relay	35
2.7.3 Reactive maintenance	35
2.7.4 Cost of customer reliability	36
<b>CHAPTER 3: AN OVERVIEW OF BC'S SUB-TRANSMISSION NETWORK</b>	38
3.1 Introduction	38
3.2 Main source of supply	39
3.3 Main equipment	40
3.3.1 Overhead lines	41
3.3.2 Substations and transformers	41

3.3.3 Circuit breakers	42
3.4 Protection scheme review	43
3.5 Network reliability problems	45
3.5.1 Categorisation of problems	45
3.5.1.1 Aging infrastructure	45
3.5.1.2 Protection relay failures	46
3.5.1.3 Maintenance strategy	46
3.5.1.4 Blackouts	46
3.6 Case study based on experienced blackouts	47
3.6.1 Case study 1: (Blackout of 18 <sup>th</sup> March 2006)	47
3.6.1.1 Impact from the outage	50
3.6.1.2 Restoration process	50
3.6.2 Case study 2: (Blackout of 11 <sup>th</sup> January 2008)	50
<b>CHAPTER 4: LOAD FLOW STUDY ON BC'S NETWORK</b>	<b>53</b>
4.1 Introduction	53
4.2 Sub-transmission model	53
4.3 Existing network model	56
4.4 Alternative (1) network model	60
4.5 Alternative (2) network model	62
4.6 Comparative analysis of existing and alternative (1) network models	65
4.7 Cost effectiveness of alternative (1) and (2) network models	67
<b>CHAPTER 5: FAULT LEVEL ON BC'S NETWORK</b>	<b>69</b>
5.1 Introduction	69
5.2 Types of faults	69
5.2.1 Three phase fault	70
5.2.2 Single line-to-ground fault	71
5.2.3 Line-to-line fault	72

5.2.4 Double line-to-ground fault	72
5.3 Comparison of existing and alternative (1) fault level simulations	73
5.4 Existing network fault level simulation	74
5.5 Alternative (1) network fault level simulation	74
5.6 Fault level comparative analysis	74
<b>CHAPTER 6: DISCUSSIONS</b>	<b>77</b>
6.1 Aging infrastructure equipment	77
6.2 Reactive maintenance	78
6.3 Non-responsiveness of protective devices	78
6.4 Load flow on BC's network	79
6.4 Fault level on BC's network	79
<b>CHAPTER 7: CONCLUSIONS AND RECOMMENDATIONS</b>	<b>81</b>
7.1 Conclusions	81
7.2 Recommendations	82
7.2.1 Aging infrastructure equipment	82
7.2.2 Planned preventative maintenance	83
7.2.3 Protection system on BC's network	83
7.2.4 Load flow on BC's network	84
7.2.5 Fault level on BC's network	85
<b>REFERENCES</b>	<b>86</b>
<b>APPENDICES</b>	<b>93</b>

## LIST OF FIGURES

Figure 1.1: System diagram of the infeed and Stafford/Stoney Drift/Progress arrangement	5
Figure 2.1: Bathtub curve: Component failure rate vs age	10
Figure 2.2: Failure rate vs time for regular maintenance intervals	11
Figure 2.3: Illustration of the escalation of component failure rates	13
Figure 2.4: Subdivision of system reliability	14
Figure 2.5: General reliability model of a protective system	18
Figure 2.6: Overcurrent system protection of a feeder	18
Figure 2.7: Detailed reliability model	21
Figure 2.8: Links required for decision making by condition monitoring	22
Figure 2.9: Evaluation of maintenance strategies	25
Figure 2.10 Selection of maintenance strategy for component or component groups	
Figure 2.11: The basic concept associated with power system reliability cost/worth evaluation	31
Figure 2.12: Total reliability costs	33
Figure 2.13: The relationship between reliability and aging infrastructure, relay failures and reactive maintenance for this study	36
Figure 3.1: 132 kV Stafford/Stoney Drift/Progress overhead line route length	38
Figure 3.2: Existing BCMM's sub-transmission network	40
Figure 3.3: Stafford – Progress tee-off 132 kV feeders.	41
Figure 3.4: Stoney Drift HV/MV yard arrangement with 16 circuit breakers	43
Figure 3.5: Single line diagram of existing protection scheme	44
Figure 3.6a: Chiselhurst switch house system diagram (sheet 1)	48
Figure 3.6b: Chiselhurst switch house system diagram (sheet 2)	49
Figure 3.7: Vincent Park switch house system diagram	49
Figure 3.8: Progress substation HV arrangement with six circuit breakers	51
Figure 4.1: Short line model with a “Pi” section with lumped parameters	55
Figure 4.2: Short line with load	55

Figure 4.3: Short line 2-port model	56
Figure 4.4: Existing network simulation results	59
Figure 4.5: Alternative (1) network simulation results	61
Figure 4.6: Single line diagram of alternative (1) network model	62
Figure 4.7: Alternative (2) Stoney Drift substation single line diagram	63
Figure 4.8: Alternative (2) Progress substation upgrade single line diagram	64
Figure 4.9: Alternative (2) sub-transmission network configured model	65
Figure 5.1: General representation of a balanced three-phase fault	71
Figure 5.2: General representation of a single line-to-ground fault	71
Figure 5.3: General representation of a line-to-line fault	72
Figure 5.4: General representation of a double line-to-ground fault	73

## **LIST OF TABLES**

Table 3.1: Substations and transformers	42
Table 3.2: BCMM's sub-transmission circuit breakers	43
Table 4.1: Overview of line model as available in Power Factory	54
Table 4.2: Line type data for Stafford/Stoney Drift/Progress line	56
Table 4.3: Transformer type data 1	57
Table 4.4: Transformer type data 2	57
Table 4.5: Tower geometry type	58
Table 4.6: Colour legend	61
Table 4.7: Transformers older than 35 years	63
Table 4.8: Provisional cost estimates	68
Table 5.1: Comparative fault level analysis	75

## **LIST OF ABBREVIATIONS**

A	Ampere
AC	Alternating Current
BCMM	Buffalo City Metropolitan Municipality
BC	Buffalo City
CBD	Central Business District
CT	Current Transformer
CBM	Condition Based Maintenance
CIC	Customer Interruption Cost
CDF	Customer Damage Function
DC	Direct Current
EDI	Electricity Distribution Industry
EF	Earth Fault
HV	High Voltage
Hz	Hertz
ICDF	Individual Customer Damage Functions
IEEE	Institute of Electrical and Electronic Engineers
IEC	International Electrical Commission
KV	Kilovolt
KA	Kilo Amps
KVAR	Kilo Volt Ampere Reactive
Km	Kilometre
LF	Load Flow
LFA	Load Flow Analysis
MW	Mega Watt
MVA	Mega Volt Ampere

MV	Medium Voltage
MVAR	Megavolt Ampere Reactive
NEC	Neutral Earth Compensator
O&M	Operations and Maintenance
OPGW	Optic Ground Wire
OC	Over Current
OC	Outage Costs
PSU	Power Supply Unit
PES	Power Engineering Society
PM	Preventative Maintenance
PT	Potential Transformer
P	Power
PT	Permissible Trip
POTT	Permissive Overreaching Transfer Trip
Q	Reactive Power
R	Resistance
RED	Regional Electricity Distribution
RCM	Reliability Centered Maintenance
RC	Reliability Cost
SIC	Standardized Industrial Classifications
SCADA	Supervisory Control and Data Acquisition
TBM	Time Based Maintenance
TC	Total Cost
VT	Voltage Transformer

## **CHAPTER 1: INTRODUCTION**

Continuous electricity supply is imperative for living in urban area. Any form of power interruptions cause dissatisfaction in the lives of people. Power interruption can be either planned or unplanned nature. This chapter is the overview of regular unplanned power outages that lead to the need to review the reliability performance of dependability and security of Buffalo City Metropolitan Municipality (BCMM)'s sub-transmission as a whole and the infeed in particular, to identify a relevant problem statement and the research questions that guide the investigations in this dissertation.

BC is the electrical energy service provider to the City of East London. The BC's network is known as Stafford/Progress/Stoney Drift line. This network supply electricity to the two main distribution hubs namely Progress and Stoney Drift substations. Stoney Drift substation distribute supply to the main switch houses for further distribution including Chiselhurst switch house. Detailed overview of BC's sub-transmission network is presented in chapter 3.

### **1.1 Problems of loss of supply**

The reliability problems on power system network is the persisting outages including blackouts. The nature of the problems may be protection failures, lack of maintenance and lack of design imperatives. These lack of design essentials range from; no circuit breakers are made available for the protection of the outgoing feeders from Stafford, no circuit breakers to protect the incoming feeders to Stoney Drift substation, to no infeed circuit breakers to Stafford switchyard; reliability is jeopardise in Stafford switchyard, Stoney Drift substation and the entire network at large in BC. The other latent problems are the aging power system infrastructure, nonexistence of pilot wires between Stafford switchyard and Stoney Drift substation, and lack of planned preventative maintenance.

A blackout incident may be caused as a result of protection limitations:

- Protection system failure to operate quickly enough and selectively in a presence of a fault.

IMPROVING BUFFALO CITY'S SUB-TRANSMISSION RELIABILITY  
INTRODUCTION

- Inadvertent operation during conditions where no system or plant fault is present.

Whilst the first failure mode is self-explanatory, an interesting and actual example of the second failure mode was experienced in Chiselhurst switch house (adjacent Stoney Drift substation) and Progress substation on Buffalo City's (BC's) 132 kV sub-transmission network on 18<sup>th</sup> March 2006 and 11<sup>th</sup> March 2008 respectively. This event highlighted the need for a review of the whole system, particularly of the protection systems.

### **1.2 Unreliability**

In power supply networks, the generation of power and the electrical load or demand side must be very close to equal every second since instantaneous equality is necessary for system stability. The components used to automatically detect overloads, earth fault and short circuit to disconnect circuits at risk of damage are the protective relays and fuses. However, under certain conditions, the shutting down of a component can cause current fluctuations in the network neighbouring segments leading to a failure of a larger section. For instance, this may range from a building to a block, to an entire city and to an entire electrical grid. The persistence (for instance in 2009/2010 financial year, 374 high voltage (HV) faults outage was recorded) of the regular power system outages is the key reason for unreliability problems and power interruptions which has imparted on industrial, commercial and domestic customers and utility's cost as well as quality of service.

### **1.3 Causes of power interruptions**

It is important to know about the possible cause of power outages in order to better protect the utility's system and businesses from its devastating effects. The power outage can be forced (unplanned) or unforced (planned) interruption. The unplanned interruptions are due to failures in the system caused by:

- Inherent factors, such as aging of the infrastructure, manufacturing defects and lack of maintenance;
- Environmental factors includes, trees, wind, birds/animals, ice, lightning; and

IMPROVING BUFFALO CITY'S SUB-TRANSMISSION RELIABILITY  
INTRODUCTION

● Human errors, such as vehicular accident, operating err, and accident caused by utility personnel or contractor crew [1 & 2]. The causes of many persisting outages in BCMM may often directly relate to quality of service and reliability problems. The contributory factors to power interruption problems in BC may be as follows:

- Aging of equipment and infrastructure
- Lack of planned preventative maintenance of existing infrastructure
- Inability to upgrade and reinforce existing network
- Protection system failures
- Failure of communication equipment
- Protection relay grading
- Vandalism and theft of infrastructure
- Inclement of weather conditions
- Manpower shortages

These unsatisfactory event of Chiselhurst switch house (adjacent Stoney Drift substation) and Progress substation highlighted the dire need to review the problems on the system including protection failures and lack of planned preventative maintenance.

The reliability of sub-transmission system in Buffalo City may not be satisfactory since there are number of outages occurred regularly on the network. The functionality of an automatic devices known as protective relays and fuses for discrimination and disconnection of faulty equipment on the network may be non-responsive. The role played by power system protection in power blackouts situation is important. The protection is designed to detect specific types of primary plant fault and initiate rapid disconnection of the faulty component. However, many major faults have been occurred on the Stafford switchyard and Stoney Drift sub-transmission network and two previous power blackouts have been catastrophic. There are several reasons for such a situation to exist. Both the incorrect response of protection systems to faults and the operation of relays in the

IMPROVING BUFFALO CITY'S SUB-TRANSMISSION RELIABILITY  
INTRODUCTION

absence of faults introduced above, contribute to the problems in BC. There are other reasons contributed to the situation.

Firstly, demand for electricity has increased steadily for decades, yet transmission lines that transport power from infeed to customers have not been refurbished or upgraded at the same pace. As a result, the grid has become vulnerable, making it more prone to blackouts, which have risen in number and severity [3].

Secondly, the lack of incentive in investing in new transmission facilities and the absence of effective cost recovery mechanisms for transmission investments has caused serious problem of transmission inadequacy [4]. The expectation of electricity distribution industry (EDI) restructuring initiatives of establishing regional electricity distribution (RED) to ring fence Municipality electricity distribution business to be financially viable was discontinued. The RED was formally established in July 2005 and ended in 2010/2011 financial year; after six years. The objectives and benefits includes improvements in efficiency, rationalisation of tariffs, electrification and sustainability [5]. The initiative activities, such as restructuring and re-regulation, are needed to reach the objectives, but are often expressed as an end-objectives or not materialised.

In many cases, an initial incident results in the disconnection of a small amount of faulty primary plant. For instance, a fault occurred on the down-stream of a transformer will cause sectional failure. The incident may then escalate, either because the removal of primary plant item imposes additional stresses on the overall network, or because the initial incident cannot be contained and the consequences of the initial fault progressively spread into the rest of the power system and non-responsiveness of protective device may be resulted in blackouts. The two major faults (Progress substation and Chiselhurst switch house) among many occurrence on BC's network, are characteristic of a more generally unacceptable level of performance. For example 374 HV fault outages was recorded in one financial year (2009/2010). The electric service power interruptions and the impact on consumers such as domestic, commercial and industrial is presented in appendix B. Figure 1.1 below depicts system diagram of

IMPROVING BUFFALO CITY'S SUB-TRANSMISSION RELIABILITY  
INTRODUCTION

infeed circuit breakers situated in Eskom's Buffalo substation and Stafford switchyard.

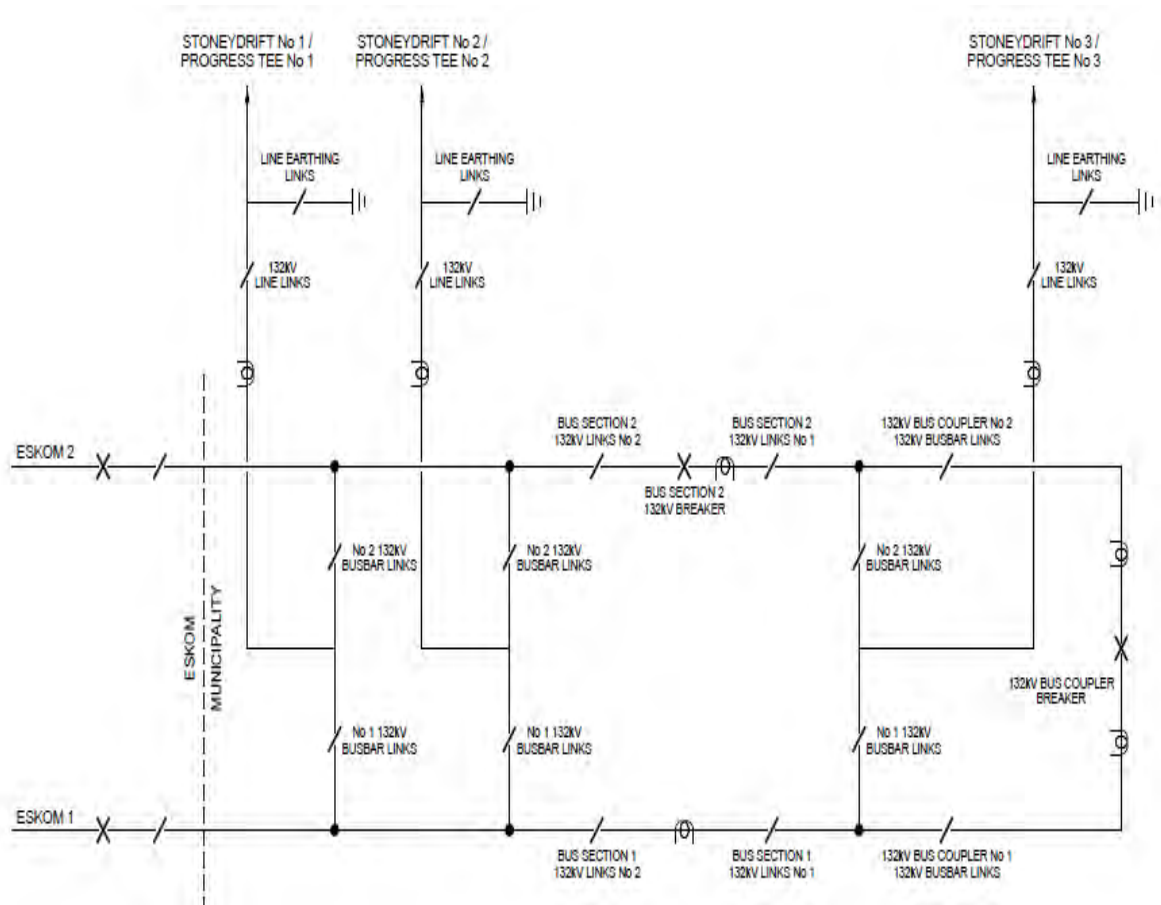

**Figure 1.1:** System diagram of the infeed and Stafford/Stoney Drift/Progress arrangement with two circuit breakers.

#### 1.4 Possibilities for improvement

A reliable power system is an effective mechanism for industrial and economic growth, emergency services, household use, farming, education etc. To achieve that, BC's sub-transmission must maintain to an acceptable level of reliability performance and the frequency of power interruption must be reduced. The reduction of power outage frequency may be achieved through refurbishment, maintenance strategy, relevant protection scheme, proper discrimination, correct grading and setting of protection relays, staff compliment and reinstate of pilot wires. The reliability improvement of power system is very complex with many technologies, such as smart-grid etc., and other strategies available. However, there is a need to follow a structured approach to the research to find relevant solutions.

### **1.5 Problem statement**

The improvement of sub-transmission system's reliability is essential, since it is impossible to eliminate completely random faults and failures from BC's sub-transmission network, it is necessary to measure security and perform analysis, then take measures to reduce the likelihood that disturbances degenerate into major blackouts and prepare a structure for investigation.

### **1.6 Research questions**

To improve reliability performance, the frequency of power outages must be reasonably decreased to an economically acceptable level. In order to achieve that, the following research questions have been raised to guide the investigation of this research.

1. How can evaluation and upkeep of aged infrastructure improve reliability?
2. Is there any significant relationship between relay responsiveness and reliability improvement?
3. How can planned preventative maintenance make a difference in reliability improvement?
4. How can blackouts mitigation and possibly prevention improve reliability?
5. What is the reasonable cost for reliability improvement?

The exploration of the above questions will confirm the importance of reliability improvement; to investigate the sub-transmission network and help determine a structure that might lead to insight and solutions to validate the research questions.

### **1.7 Methodology**

The research may be broadly described as an investigation into BC's sub-transmission protection system, system dependability and maintenance. The records of past practical problems of unreliability will be explored and investigated.

IMPROVING BUFFALO CITY'S SUB-TRANSMISSION RELIABILITY  
INTRODUCTION

There is a planning study, data acquisition, and exploration phases. Within the study phase, facets of the research topics are explored.

In the data acquisition stage, factors of influence for sub-transmission protection, security, dependability and maintenance are identified and their relationships are explored. The drivers of influence linking or relating to the performance of sub-transmission reliability are also explored. Data acquisition may be carried out by expert interviews of distribution personnel, site visitations and existing reports.

In the second phase, review and blackouts happenings on the sub-transmission network; and various aspects of factors of influence affecting the reliability performance on the network may be investigated. BC's sub-transmission and main component of the network system will be reviewed.

In the third phase of the research, discussions on a desk study of possible solutions, and selection of best solution that uses decision making approach may be implemented. The exploration of protective equipment reliability performance; security, dependability and maintenance may be reviewed by combining fault current calculations and protection settings is the fourth phase of the research. It is possible to explore the effects of these combination of strategies on the performance of equipment and profitability of the BC's network. Work out recommendations based on the above mentioned investigations. Preliminary analysis indicates a study of the pilot protection system could make a difference to the reliability improvement. The load flow, fault current calculations and protection settings need to be reviewed. These will lead to a plan that will deliver necessary reliability improvement. The methodology employed for this research offers significant potential for application to a range of power system reliability problems.

### **1.8 Organisation of the dissertation**

This dissertation contains seven chapters and is organised as follows:

Chapter 1 provides a basic introduction to the research as well as the problems, the causes and the possible improvement as the reasons behind this research. This

IMPROVING BUFFALO CITY'S SUB-TRANSMISSION RELIABILITY  
INTRODUCTION

chapter also includes research methodologies, problem statement and research questions to guide the research to the knowledge of power system reliability.

Chapter 2 presents literature review of aging infrastructure, unresponsiveness of protective relay. This chapter also review the literature on maintenance strategy, mitigation and prevention of blackouts and cost of reliability as well as customer satisfaction.

Chapter 3 elaborate on the overview of BC's sub-transmission network, the source of supply, the main transmission equipment, BC's protection scheme categorisation of problems and the case study of experienced blackouts on the sub-transmission network.

In chapter 4, load flow analysis of the sub-transmission network was carried out. The overhead lines, transformers, tap changers etc. were modelled and simulated. Simulation was also carried out the alternative (1) network model for comparative analysis.

Chapter 5, types of fault and fault level model from Stafford switchyard to Stoney Drift substation were simulated and presented. Comparative analysis will be carried out to make an informed decision.

Chapter 6 further emphasised on BC's network problems and findings in discussions to enable appropriate recommendations.

Chapter 7, Conclusions and recommendations for reliability improvement of BCMM's sub-transmission network will be elaborated and followed by the references and appendices.

## **CHAPTER 2: LITERATURE REVIEW**

The published literature is to guide the research study and existing literature is relevant to the key problem areas in chapter 1. The literature critically review sections devoted to each area of research question. Identification and articulation of the relationships between literature and field of research, will present all the important sense of knowledge that will catalyst solutions. This literature review will examine the factors contributing to supply interruptions between interconnected substations, and possible solutions. The role of pilot protection scheme should play an important role in pursuit of improving system reliability will be discussed. The study of literature review will focus on research questions as set out in section 1.6 in chapter one.

### **2.1 Introduction**

In the first part of this chapter, aging infrastructure and concept of power system equipment life time will be briefly introduced. In the subsequent sections, we will discuss protective relay and reliability of protection systems: dependability and security, the failure modes of protection systems, causes of relay non-responsiveness, and catastrophic failures in power systems. Appropriate maintenance strategy (planned preventative maintenance), experienced blackouts and cost of reliability will also be presented. This chapter will provide the reader with the appropriate theoretical background, understanding the approach in evaluating aging infrastructure, relay failures (hidden faults) and reactive maintenance which lead to catastrophic failures. Historical works in related areas such as security analysis, Markov model, and equipment life cycle optimisation for mitigation of power outages will be investigated with the intention of drawing conclusions on the significant relationships affecting reliability performance.

### **2.2 Aging power system infrastructure**

Aging electrical sub-transmission infrastructure is evident in both the developed and developing countries around the world. Power system infrastructure aging is an undeniable fact in the life of sub-transmission network. Many utilities around the world have plants or equipment that have been classified as aged due to their

bad performance and increasing failure rate. The failures and outages of these equipment are higher than the acceptable level and continue increasing.

*“Studies corresponding to the equipment aging of equipment modelling so far have focused on transmission system [6-8]. Electrical power systems are formed from components such as poles, overhead lines, underground cables, circuit breakers, power transformers etc.,. With the passage of time, the more the life of a power system, the more its components become aged or old. No repairing and possibly lack of accurate timing of replacement of old equipment, overloading and regular power outages of the system can be mentioned as reasons of aging the distribution system [6]. Figure 2.1 graphically shows the bathtub curve which indicates the relationship between fault rate and age of component. As it can be seen in the Figure below, this curve includes three stages.*

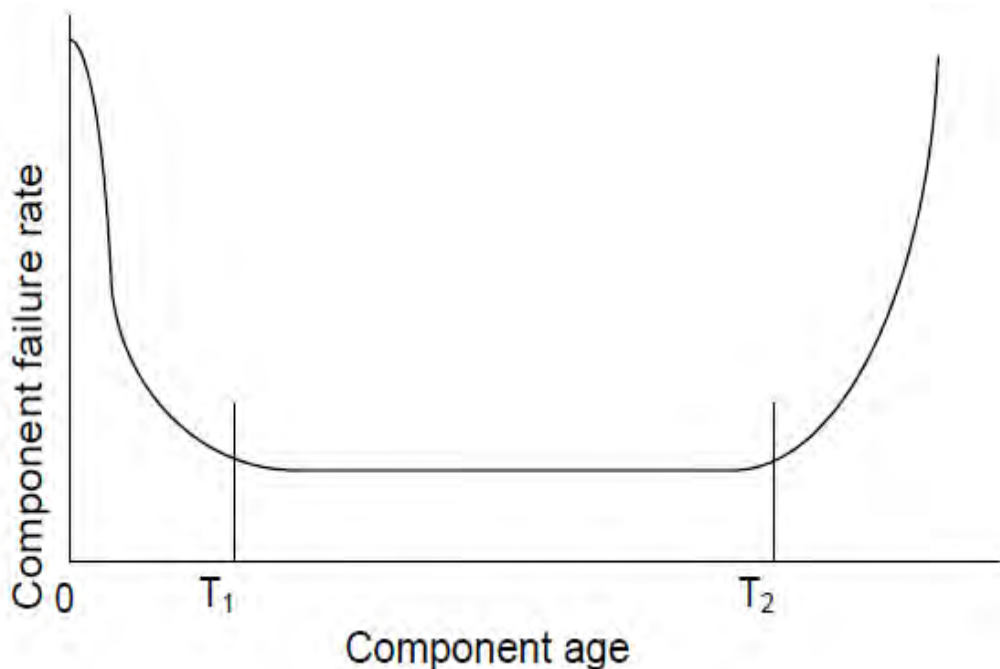

**Figure 2.1:** Bathtub curve: Component failure rate vs age (Adapted from [9])

*The Bathtub curve, Figure 2.1, quantifies the occurrence of equipment failure rate through the aging of equipment. The period 0 to  $T_1$  is known as the wear-in-period, period  $T_1$  to  $T_2$  is the useful life of the equipment and the time when it is more valuable to the user, and  $T_2$  is the wear-out period. In Figure 2.2,*

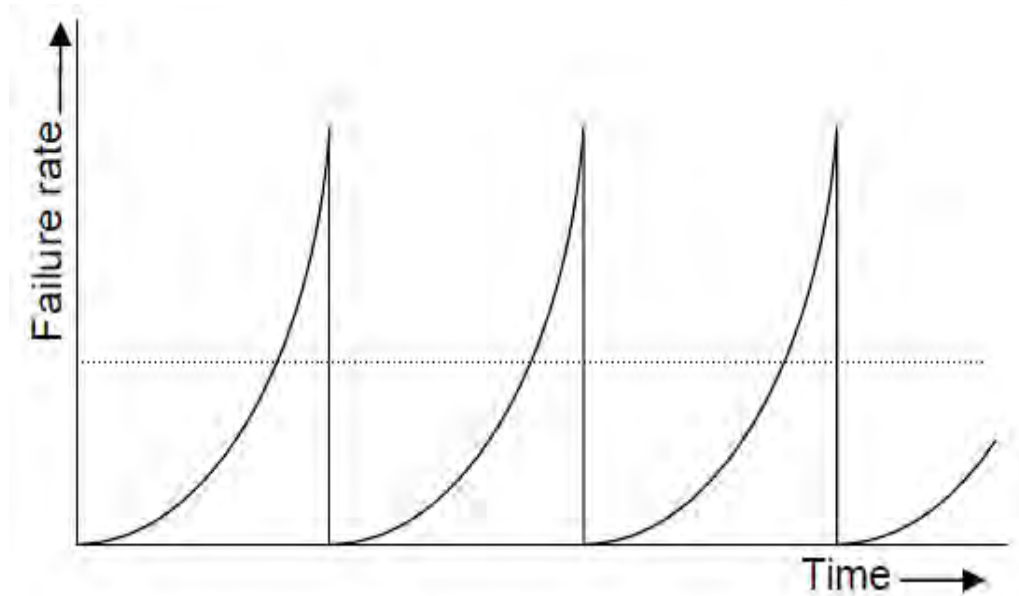

**Figure 2.2:** Failure rate vs time for regular maintenance intervals (Adapted from [9])

*the failure rate increases with time until the equipment is maintained. After maintenance, the failure rate drops to the original value. The dotted line represents the average failure rate” [9].*

### **2.2.1 Equipment aging**

*“Today, preserving and or enhancing system reliability and reducing operation and maintenance cost are top priorities for electric utilities [10]. A utility purchase sub-transmission and distribution components such as poles, lines, transformers, circuit breakers, switchgears etc., constructing it and put it in to operation leaving it in service while tending to it with maintenance and repair as necessary until it fails, at which point it is replaced. Power system equipment deteriorates (wear out) while in service for a host of causes. These include sustained heating due to current flow, insulation degradation due to voltage stress, wear and material fatigue of mechanical parts, corrosion from chemicals in the soil, air, and a slow but steady deterioration due to the effects of sun, wind, rain, ice and snow. As power system equipment continues to age and gradually deteriorates the probability of service interruption due to component failure increases” [11].*

### **2.2.2 Concept of power system equipment life time**

*“Power system equipment performs both technical and economic functions in the network. There are three different concepts of the life time of power system equipment:*

- *Physical life time; A piece of equipment starts to operate from its brand new condition to a status in which it can no longer be used in normal operating state and must be retired. Preventative maintenance can prolong its physical life time.*
- *Technical life time; A piece of equipment may have to be replaced due to technical reason although it may still be physically used.*
- *Economic life time; A piece of equipment no longer valuable economically, although it still may be usable physically. There are two methods for estimating economic life time:*

*1. The capital value of any power system equipment each depreciation every year. Once the remaining capital approaches zero, the equipment reaches the end of its economic life time.*

*2. In addition to the depreciating the capital cost of the equipment, operating and maintenance are considered. Operating and maintenance (O&M) cost usually increases over time as equipment ages and may become excessive. They may even exceed the depreciation value of the equipment. It could be cost effective to decommission and replace the equipment before its capital value reaches zero rather than continue to force high O&M costs” [12].*

### **2.2.3 Reliability issues with aging equipment**

*“In developed Countries (North-American and European), the other leading cause of increased grid failures is the age of an infrastructure that was built decades ago. Circuit breakers are an integral part of this infrastructure. The age and weaknesses of such power systems are apparent, especially when it comes to powering sophisticated equipment that requires highly reliable supplies. The May 2006 issue of IEEE Power & Energy Magazine was titled “The Graying Power System” and was entirely devoted to the state and aging problems of electric grids.*

*Although investments tend to be cyclic, no massive improvements to the U.S. power systems infrastructure have been made since the late 1960s [13]. As a result, the vast majority of the grid equipment is now 40 years old or more. Experts note that*

such a remarkably long service age comes from the robust construction of the equipment itself. But ultimately, old equipment wears out. With failure rates that abruptly increase with age, old equipment contributes to system unreliability [14].

The concern for utilities is not the aging of a single device, but the large amount of equipment simultaneously reaching an age that is synonymous with high failure rates, as graphically shown in Figure 2.3. This phenomenon is known as the 'escalation' of component failure rates. Utilities use this terminology to anticipate the potentially overwhelming costs to maintain and to replace old equipment" [15] & [16].

"Circuit breakers, transformers and switchgears are no exception to this observation of aging power systems in need for overdue upgrades. The replacement of circuit breakers in a single substation already costs millions of dollars. Considering the important number of substations in major grids, budget-related delays in equipment maintenance and upgrades and the lack of manpower to complete these upgrades adversely affect the reliability of power systems.

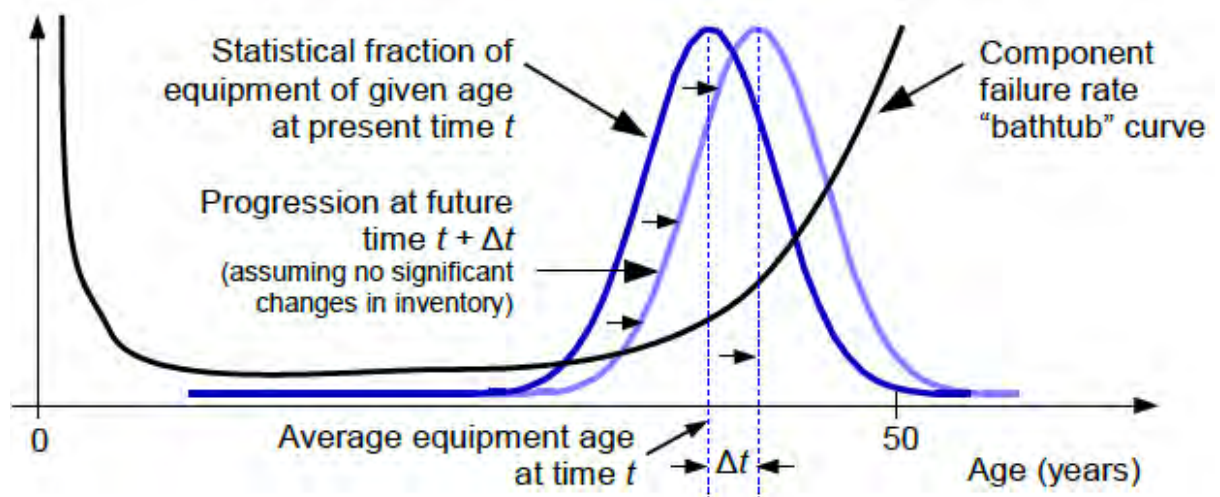

**Figure 2.3:** Illustration of the escalation of component failure rates [17].

The combination of equipment aging and equipment operation beyond its rated current significantly increases the chances of system failures. Safety and operational margins are reduced at the same time" [17].

### 2.3 Non-responsiveness of protective devices

The non-responsiveness of protective devices turn to complicate the whole network system and infringe the right of power system to operate successfully. The problem could emanate from hidden faults, lack of protection scheme maintenance, human intervention (vandalism or theft) etc. Protective devices play a vital role for power system to function properly and satisfactorily to meet consumer quality of supply expectations.

#### 2.3.1 Introduction

Electrical power is vital important to our modern society nowadays with its associated challenges to provide most efficient and cost effective ways of supplying electricity from generation, and transmitted to residential, commercial and industrial consumers.. The availability of reliable power supply at reasonable cost is crucial for economic growth and development of the country [18]. An analysis throughout the world shows that 90% of all customer reliability problems are due to the problems in distribution system. Thus, improving reliability on distribution system is the key to improving customer reliability satisfaction [19]. The concept of power system reliability is extremely important to satisfy customer requirements. Figure 2.4 shows the reliability subdivision. [18]

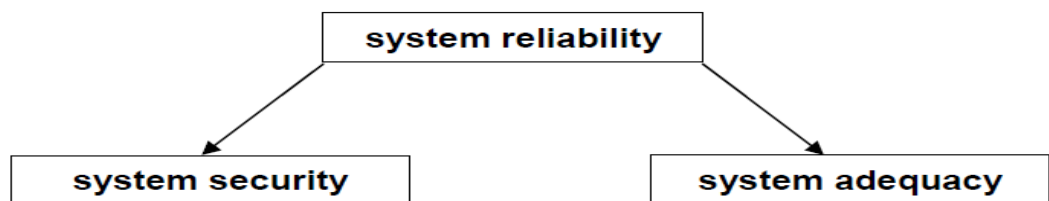

**Figure 2.4:** Subdivision of system reliability (adapted from [18])

Reliability comprises two important elements that are system dependability and security of system operation. Dependability is the degree of certainty that a relay or relay system will operate correctly, and security on the other hand is the degree of certainty that a relay or relay system will not operate incorrectly. In other words, dependability means that the relay will operate correctly when a fault occurs, and

security on the other hand means that the relay will not operate when there is no fault.

### **2.3.2 Reliability of protection system**

*“Protection systems play a vital role in maintaining the high degree of service reliability required in present day power systems. The two primary failure modes of a relay are failure to operate and incorrect operation. Relay reliability considerations are usually separated into the two different aspects of dependability and security [20]. Dependability is defined as the probability that the relaying system will operate correctly. In other words, dependability is a measure of the relay’s ability to operate when required. Security is defined as the probability that a relay will not operate in those situations when tripping is not desired [21]. In order to enhance both dependability and security, appropriate testing and inspection of the protective system should be performed. Considerable work has been done to examine different reliability aspects of protection systems. Reference [22] introduces a method to calculate the probability of failure of protective relay systems. A reliability index designated as “unreadiness probability” is defined in [23] as the probability that the relay system fails to respond when called upon to operate in the presence of a fault. The proposed model in [23] has been extended and improved in [24] to redefine the unreadiness probability and unavailability of a protection system. The improved model recognizes the operation of back-up protection, the removal of protection for inspection, the occurrence of common-cause failures, and the fault clearing phenomena” [20]*

*“Modern digital relays are normally equipped with self-checking and monitoring facilities. The impact on the performance of the relay and the benefits to be expected from the use of these facilities are discussed in various papers [25]–[27]. Reference [28] illustrates a Markov model to predict the optimum routine test interval for a protective relay with and without self-testing capabilities. Two different indexes of “abnormal unavailability” and “protection unavailability” are defined as the probability that the relay will be out of service while the system is energized and the probability that the relay does not respond when a fault occurs. An improved reliability model for redundant protective systems is presented in [29]. Hidden failures in protection systems and a methodology for identifying them*

*are discussed in [30] and [31]. The failures are considered as the key contributors in the degradation of power system wide-area disturbances (blackouts)” [30, 31]*

### **2.3.3 Failure modes of protection system**

Considering the vast number of relays existing on a power system, protection systems are highly reliable; however, 100 percent reliability is realistically unattainable. Incorrect or unwanted relay operations have occurred in the 2006 Chiselhurst switch house blackout and the 2008 Progress substation blackout as detailed in subsections 3.6.1 and 3.6.2 respectively.

The performance of protection systems can be classified into the categories of ‘correct operation’, which accounts for relays performing correctly based on the input signals, and ‘incorrect operation’, which results from a failure to perform its planned functions [32]. In the Correct Operation category, we should be aware of ‘unwanted operation’, even when the protection system responds correctly to the system conditions; this scenario was demonstrated by the Chiselhurst blackout (see section 3.6.1). There are two modes of possible improper relaying. The first, failure to operate for a legitimate internal fault within the zone of protection relegates tripping to backup relaying (Incorrect Operation). The longer the fault clearing time, the greater the potential for line or equipment damage as well as system instability. *“The second mode is false operation for a fault outside of the protected zone (undesired tripping). This can cause incorrect isolation of a no-trouble area. Undesired tripping could be triggered by a heavy loading condition in the absence of a fault or in post-fault conditions, or by miscoordination between primary relays and backup relays due to whatever reason, such as current and potential transformers, (CT/PT) errors, settings without enough margin, and/or hidden failures of relay components. Many utilities have experienced this type of failure.*

*Different types of relays may have different probabilities of undesired tripping. The electromechanical and static protection relays used in transmission systems become a major risk as their level of reliability decreases. Even if checked periodically, these relays often cause misoperations, leading to cascading outages.*

*The impact of protection system failure depends on the condition of the power system when it occurs. Power system operation is greatly affected by these two different failure modes, and they have significant effects on the system reliability evaluation due to their differences in the number, order, and likelihood of contingencies. In either of the above cases, customers and utilities can experience problems resulting from misoperations in the sub-transmission system [32].*

#### **2.3.4 Causes of relay misoperation**

*“There are four main causes contributing to incorrect operations and they are:*

- 1) Inappropriate design or application of relay schemes;*
- 2) Inappropriate settings for some specific system condition;*
- 3) Human error; and*
- 4) Component malfunction” [31].*

*“Since the first three factors are hard to quantify, they tend to be more related to the policy, practice, and the management of individual utilities, and thus are hard to control from the point of view of relay engineers; engineers are more interested in quantitative analysis of the equipment malfunction.*

*The above four categories may not be all-inclusive, but these are the major factors involved in the misoperation of a protective system. Other classifications may be used by different systems; for example, the WSCC groups the failures of protection system into six categories” [32]. Communications, components, settings, design, procedures and scheme are as follows:*

- 1) Communications: problem with the communications channel, line trap, turning equipment, pilot wires etc;*
- 2) Components: a failure of a part or module of a relay or a component relay;*
- 3) Settings: inappropriate relay settings, either calculated or applied;*
- 4) Design: design errors or inappropriate design of circuit;*
- 5) Procedures: Improper procedures include problems caused by maintenance procedures, test and installation procedures; this also includes switching or operational procedures; and*
- 6) Scheme: An inappropriate protection scheme is used” [32].*

### 2.3.5 Reliability modelling of protection systems

“In this subsection, the general five state reliability model introduced in [33] and shown in Figure 2.5 is extended to a 65-state Markov Model to examine different reliability aspects of a none-pilot Directional Overcurrent Protection of a transmission line shown in Figure 2.6” [33].

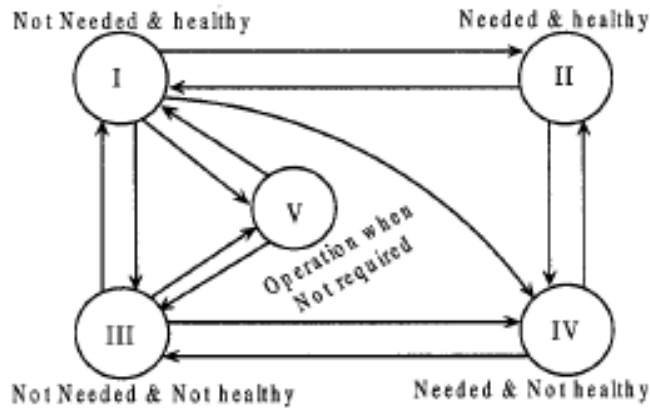

Figure 2.5: General reliability model of a protective system (adapted from [33])

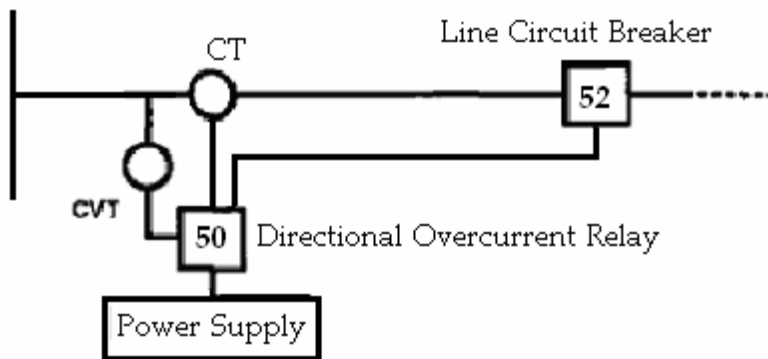

Figure 2.6: Overcurrent system protection of a feeder (adapted from [33])

#### 2.3.5.1 General reliability model

“A general reliability model for any protective system can be shown as Figure 2.5. In this model, state I represents the state in which a protective system spends most of its life, in a healthy and perfect condition, monitoring an operating component within its protective zone. This state is designated as “Not Needed & Healthy”. In State II, designated as “Needed & Healthy” whose probability is a direct measure

*of dependability, the system operates correctly in response to abnormal conditions. In State III, designated as “Not Needed & Not Healthy”, the system is neither required nor ready to operate. It is not required since no fault has occurred on the protected component. It is not ready since some part of protective system has either failed, under routine test or self-checking inspection. This state can be named “Protection Unavailability State”. In State IV, designated as “Needed and Not Healthy”, the system does not perform its intended function. In this case a fault occurs and no trip signal is sent to the breakers. The probability associated with this state is “Abnormal Unavailability”. In State V, designated as “Operation When Not Required”, the system operates when it is not required. The more the probability associated with this state, the lower is the system security. It should be noted that the probability of State II depends mainly on the fault rate and equipment restoration time. This simplified model can be expanded for different relaying schemes and state probabilities can be determined using the frequency balance approach” [34].*

#### **2.3.5.2 Detailed reliability model of directional overcurrent protection system**

*“To put a step toward expanding the general reliability model, a 23-state Markov Model is presented in Figure 2.7 which refers to a more detailed model of a protection/component system where the component is a transmission line and the protection scheme is based on directional overcurrent logic. Although 23 states are shown in Figure 2.7, some of these states consist of several sub-states leading to a 65-state Markov Model.*

*The system spends vast majority of its time on state 1 where both protective system and the line are perfect and operating successfully. In this condition, protection system is ready to respond if it is called upon. In states 2 and 4, a permanent and transient fault occurs respectively on the line and the line is isolated by circuit breaker operation in states 3 and 5. Isolated line is reenergized in case of transient fault. The model transfers from state 1 to 6 when the relay undergoes self-checking. State 7 which is composed of 6 sub-states, denotes the conditions in which power supply unit (PSU), current transformer (CT), voltage transformer (VT), relay, trip coil and circuit breaker is under routine test inspections respectively. State 8 which*

IMPROVING BUFFALO CITY'S SUB-TRANSMISSION RELIABILITY  
LITERATURE REVIEW

*is composed of 6 sub-states, represents the condition in which protective components with the same order as above have failed and the failure is detectable by routine test inspections. The model transfers from state 8 to state 10 by detection of protective components failures. In this case, the transitions occur to the corresponding sub-states of state 10. The relay fails in state 9 and the failure can be detected by self-checking function. State 10 is composed of 6 sub-states in which the protective components are known to be defective. In states 11 and 12, the relay is in potential mal-trip mode and the failure is detectable by routine tests and self-checking function respectively. The occurrence of an additional failure before detecting the potential mal-trip failures will transfer the model from states 11 and 12 to state 13.1 in which a trip signal is sent to the breaker and isolates the line in state 14.1. Breaker inadvertent opening transfers the model from state 1 to 13.2 and 14.2 in which the line is isolated. In these cases, after isolation of the line, reenergizing action can be take place by switching action transferring to states 10.4 and 10.6, respectively.*

*State 15 is composed of 6 sub-states denoting the condition in which a fault occurs and the protection system is not available to respond to the situation. Depending upon which component to be defective, the model moves to corresponding states 15.1 to 15.6. The system can enter state 15.4 directly from state 1, if a simultaneous failure of the relay and the line occurs. The system will enter state 16 by isolating the line and additional healthy component X by backup protection system which is known to be fully reliable. Depending upon which of the protection system components has failed, a transition from states 15.1-15.6 to their corresponding states 16.1 to 16.6 will occur. Reconnecting the isolated component X will transfer the model to the corresponding states 17.1 to 17.6. States 6-12 represent the failure, inspection or repair process of protection system. In these conditions, if a fault occurs on the line, the protection system will not be able to send a trip signal to its associated breaker and in this case, the model transfers to state 15. While the line is isolated and the protection system is UP (state 3), the protection system can fail or the routine test inspection of different components can occur. Occurrence of the relay potential mal-trip failure in this condition will transfer the model to states 18 and 20 in which the defect can be detected respectively by self-checking and routine*

IMPROVING BUFFALO CITY'S SUB-TRANSMISSION RELIABILITY  
LITERATURE REVIEW

test inspections transferring the system to state 17.4. The only difference between state 21 and state 8 is that the line is energized in the latter while it is isolated in the former. There is a similar condition between states 23 and 7, 22 and 6, 19 and 9. The direct transition from state 1 to state 13.1 may occur due to external faults in case of erroneous relay coordination or settings. In this case the model transfers from state 13.1 to 14.1 isolating the line and then reenergizing by manual switching operation getting back to state 1. Human error in performing routine test on the relay can transfer the model from state 7.4 to state 13.1.

Abbreviations used in the model are as following:

- UP: Operational state;
- Dn: failed state;
- Du: Unrevealed failure of protection system
- Iso: Isolation of the line or neighbouring components
- Sc: The relay is removed from service for self-checking
- Rt: One of the protection system components is removed from service for routine test inspection” [34].

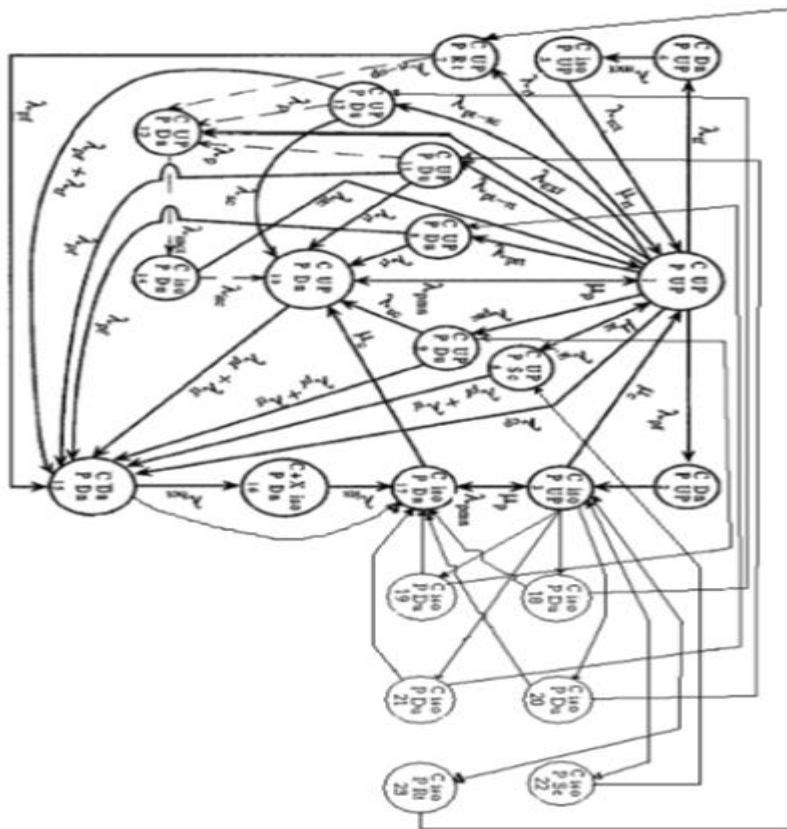

Figure 2.7: Detailed reliability model (adapted from [34])

## 2.4 Power system maintenance

Electrical power systems begin to deteriorate once they are built or installed. The performance and life expectancy of electrical systems begin to decline with environmental conditions, such as overload conditions, and excessive duty cycles. The principal reason for electrical system failure is failure to maintain (reactive maintenance) the dependable designs require preventive maintenance to keep them dependable. The power system maintenance is probably the most important strategy to mitigate regular fault outages and to sustain reliability performance. Maintenance system takes care of life cycle of infrastructure equipment. Maintenance revive equipment functionality to reach expected working life. The purpose of maintaining equipment is to maintain safe operations and production and to reduce or eliminate power system interruptions or equipment breakdown.

### 2.4.1 Optimizing equipment lifecycle

*“There are a variety of issues that must be considered when actively managing equipment over its entire lifecycle. Some of the more important include condition monitoring, life extension, repair vs replace and optimize lifecycle management.*

**a. Condition monitoring:** *Some prerequisite for a condition monitoring system is illustrated in a Figure 2.8 below.*

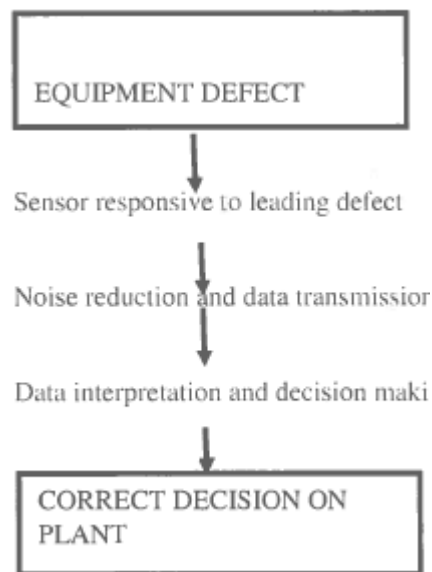

**Figure 2.8:** Links required for decision making by condition monitoring system (adapted from [35]).

IMPROVING BUFFALO CITY'S SUB-TRANSMISSION RELIABILITY  
LITERATURE REVIEW

*There are three major links in the chain in making a correct and timely decision in response to an equipment defect, whether this is incremental such as premature insulation degradation or sudden such as a defect threatening plant failure and loss of supply [35]. The more a utility can distinguish between the equipment that need attention and that which does not, the more it can cut costs while managing aging and its effect well. Condition assessment at all level of an electric system is challenging. Many utilities are placing much more emphasis on retaining and using data on condition assessment and its trends to drive changes in when and how they care for equipment. Often these efforts focused on more aggressive inspection and testing. Techniques that are becoming more popular include infrared inspection; dissolve gas-in-oil analysis, frequency response signatures and many others. Online conditioning is also becoming more popular especially for substation equipment that can be cost effectively monitor through supervisory control and data acquisition (SCADA) systems. Online techniques range from simple alarms (e.g. temperature and pressure) to continuous monitoring of dissolve gas-in-oil” [38].*

**b. Life extension:** *“Equipment replacement is often expensive, resource intensive, and operationally disruptive. For this reason utilities are increasingly looking at life extension strategies as a way to defer replacement. Often an equipment life extension program is coupled with a condition monitoring program. When the condition of a piece of equipment reaches a certain degree of deterioration, life extension options are examined for economic attractiveness” [37].*

**c. Repair vs Replace:** *“Utility practices still vary widely in this area with some utilities making explicit repair vs replace decisions. While others only replace equipment if it fails or becomes overloaded” [37].*

**d. Optimized lifecycle management:** *“The ultimate goal of a utility is to provide reliable electricity for the lowest rates. Inherent in this goal is life cycle cost minimization of equipment and the systems they constitute. Ideally the utility determines the policies of utilization, operation, inspection, maintenance-repair, retirement and replacement in an integrated manner aimed at minimizing total*

*levelized cost. In effect, the utility is optimizing expected life time vs cost. A strategy of 'over specify it' (Keep loading low. care it well) will result in equipment that lasts long time but might prove expensive to own. A strategy of 'starve it' (cut all possible costs out of the initial purchase cost. load it highly. inspect and service it infrequently) will result in equipment that cost much less to own but might fail far sooner. Somewhere in the middle there is an optimum point for every type of equipment and application [37]. This is a simple concept, but making it work is only just becoming feasible in power industry. Optimized lifecycle management requires good data, effective conditions and remaining life analysis and evaluation, sound implementation. In the middle item is a particular challenge for some equipment” [37].*

#### **2.4.2 Maintenance philosophy**

*“Since a goal of any electric utility company is to supply reliable power to customers at low cost, prevention of power system failures is of paramount importance during the design and operation of the system. Distribution systems have the greatest impact on customer outage frequency and duration. On overhead distribution systems, a fault can be classified as temporary or permanent. Approximately 75 to 90 percent of the faults are of a temporary nature caused by trees, animals, lightning, high winds, flashovers, and so on” [41].*

If temporary fault cannot be cleared by the automatic interrupting devices (auto recloser), it becomes a permanent fault that will requires attention by a Crew. Some of the failures cannot be avoided, such as lightning (surge voltage), storm damage, and insulation degradation whereas others can be prevented by proper maintenance plans. Maintenance is an important part of the equipment life-cycle, and a carrier of power systems pertinent equipment and must be highly considered from the design stage throughout the end-of-life stage of the power system. Maintenance covers two aspects of systems, operation and performance. Maintenance is generally performed in anticipation (preventative) of, or in reaction to, a failure. Maintenance is performed to ensure the upkeep of the infrastructure equipment. Once the equipment has been purchased maintenance must start. Maintenance is defined as the restoration of an item to its original condition or to its working order.

IMPROVING BUFFALO CITY'S SUB-TRANSMISSION RELIABILITY  
LITERATURE REVIEW

“Maintenance is defined in IEEE power engineering society (PES) task force report as an activity "wherein failed device has, from time to time, its deterioration arrested, reduced or eliminated". This can be achieved by repair, replacement of parts or total replacement of the item. The management makes the choice between these alternative measures based on practical and economic grounds. The decision made at the purchasing will have an input into the type of the maintenance to be carried out. In fact the manufactures/suppliers provide the details of regular maintenance schedule. This may be rigorously followed for the better performance as well as the increasing the life of equipment. Figure 2.9 below shows evolution process of maintenance strategies” [40]

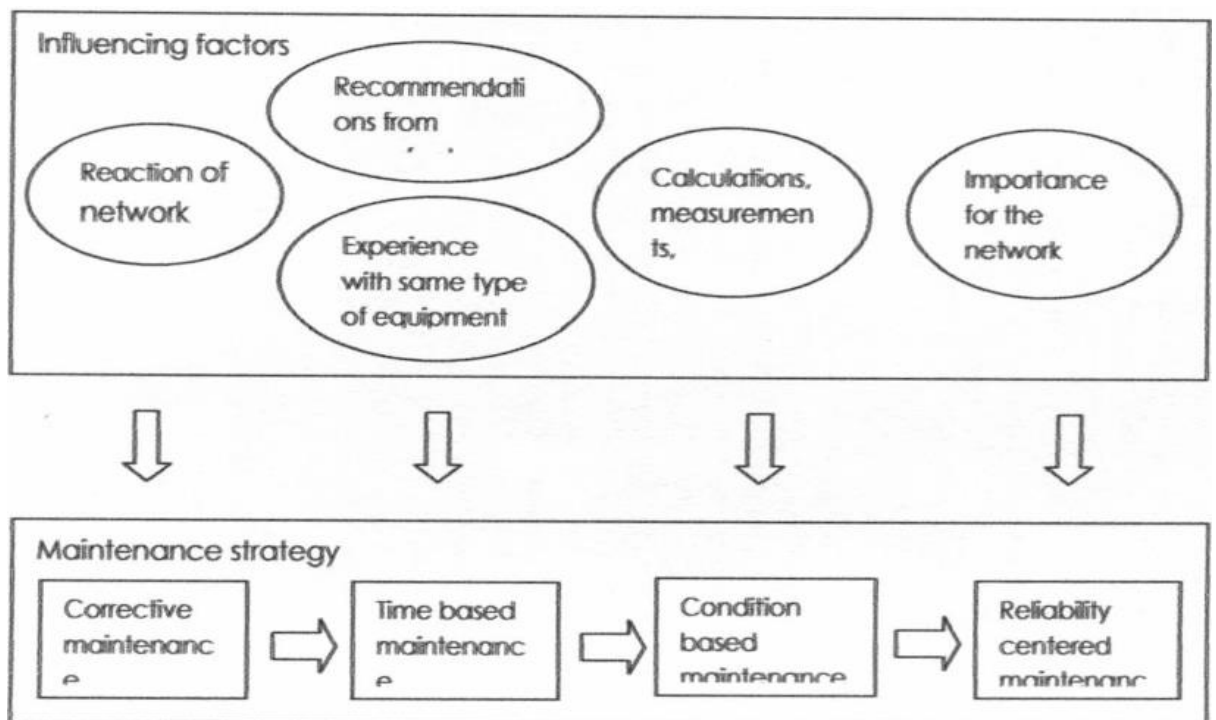

**Figure 2.9:** Evaluation of maintenance strategies (adapted from [36])

### 2.4.3 Maintenance strategy

“When the maintenance is being planned, the first decision is to select the appropriate maintenance strategy. The maintenance strategies consist of operations and means, which are chosen to achieve the set general goals of the utility within a general strategic plan. An effective maintenance is not synonym for low-cost maintenance. The most important is to see the influence of maintenance actions on the process and operation results. For example, in the case of electricity

IMPROVING BUFFALO CITY'S SUB-TRANSMISSION RELIABILITY  
LITERATURE REVIEW

*network, the results can be decreased number of outages and shortened outage times or better quality of electricity [39]. The maintenance strategy can be divide into two classes.*

*The first one is corrective maintenance and the second one is the preventive maintenance. Corrective maintenance (CM) includes faults occurred in the electricity network. Nowadays, well known strategies applied to preventive maintenance are time-based maintenance (TBM), condition based maintenance (CBM) and reliability centered maintenance (RCM) [37]. A time based maintenance strategy features predefined intervals rooted in empirical feedback, where components are checked or replaced after a specified period of use. This approach generally produces satisfactory results. However, it will not be the most cost-effective option in all cases, since the equipment will not usually remain in operation up to the end of the possible life time. Condition based maintenance is driven by technical condition of the equipment. Under this approach, all major parameters are considered in order to determine the technical condition with maximized accuracy. For this reason, detailed information via diagnostic methods or monitoring systems should be available. The condition based strategy can be considered a kind of basic strategy of developed methods. Reliability centered methods is a strategy which additionally includes a reliability-based part [36]. Aim of this approach is to combine the importance of the equipment in the network and the actual condition of the equipment. The selection of maintenance strategy has to be made for every component type and in some cases for every component. There is not only right solution for certain component, but some guidelines for the selection can be given as in Figure 2.10”.*

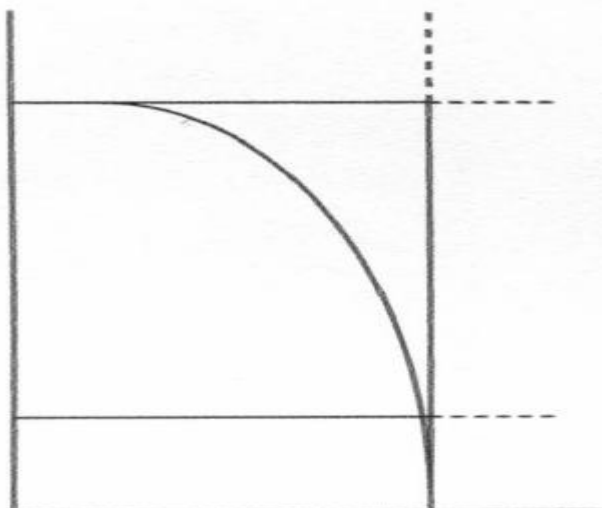

**Figure 2.10:** Selection of maintenance strategy for components or component groups (adapted from [36]).

## **2.5 Prevention and mitigation of blackouts**

A blackout is a result of a chain of accumulated contingencies and system reactions. The complete prevention of the power system blackout is almost impossible due to the uncertainty in system operation pattern, weather, human factors, etc. However, one can expect to mitigate the unfolding event against developing into a large area blackout by some carefully designed defensive strategies. Among those strategies, the analysis and monitoring tool for relay system operation is the first step since the relay misbehaviour may be a very important factor contributing to the blackout. Some useful solutions to blackouts are proposed in this literature review [42, 43–49]. *“The relation between the relay hidden failure, relay unresponsiveness and power system disturbances is analysed in [42], where the author developed a way to calculate the vulnerability index of each relay in the system to indicate which group of relays is most likely to cause a problem if and when the hidden failure or relay unresponsiveness exists. This should provide information which relay in the system should be carefully monitored. The distance protection or line protection schemes and their relation to voltage stability and transient stability is also analysed in [43], where the author provides an improvement of Zone 3 distance protection scheme to enhance the security of the protection relay operation. In [44], a wide area back-up protection expert system to prevent cascading outages is proposed. The scheme tries to precisely locate the faulted area and avoid unnecessary trip due to the relay unresponsiveness, relay hidden failure, or overload. Adaptive protection schemes are introduced to properly coordinate the relay operations and settings with the prevailing system operating conditions [45–47]. The power system protection schemes proposing the idea of coordinated protection and control means to minimize the impact of a disturbance are discussed in” [48, 49].*

### **2.5.1 Improvements on traditional relay principles**

In this literature review, it is indispensable to study improvements on new relay principles that provide enhancement to protection schemes for operational

IMPROVING BUFFALO CITY'S SUB-TRANSMISSION RELIABILITY  
LITERATURE REVIEW

excellence and reliability improvement. *“The new protection schemes that are considered to be better than the traditional transmission line protection principles or distance protection are very extensively studied in this literature review. After the digital relay is introduced, the relay principles can be realized using more flexible software means [50–53]. New fault diagnosis principles for transmission line relay are proposed. The traveling waves based relay schemes, adaptive relay schemes, neural network based relay schemes, and transients based relay schemes are developed as new directions for transmission line protection” [45–47, 54–68].* There are four other types of protection principles which has been introduced to salvage transmission line protection which are 1) travelling wave based protection, 2) adaptive protection, 3) artificial intelligent technique in protection and 4) transient based protection.

1) *“The traveling wave based protection for transmission line, which can be used for fast fault detection, was introduced in the late 1970s [50–56]. When the fault occurs on the transmission line, the traveling waves are generated from the faulted point and start moving towards both ends of the transmission line. The traveling wave based protection schemes are formed based on detection of the traveling wave at line ends. These relays have the advantage of: a) fast response, b) directionality, c) not being affected by power swing and CT saturation. However, the characteristics of existing widely-used instrument transformers are inadequate yet to support this type of protection scheme” [50-60].*

2) *“The concept of adaptive protection was introduced during the 1980s [43–45]. The concept of adaptive relaying is to make an assessment of the state of the power system first, and then automatically make adjustment to protection systems so that their settings are suitable for the prevailing conditions. The application areas of adaptive relaying could be distance protection and auto-reclosing. The advantages of adaptive relaying are: improved system responses, increased reliability and reduced costs. However, the basic principles of the various existing relays cannot be easily changed to encompass the adaptive techniques” [43-45].*

3) *“The application of artificial intelligent techniques in protection attracted researchers since 1990s [57–62]. As an example, neural networks can be used for*

IMPROVING BUFFALO CITY'S SUB-TRANSMISSION RELIABILITY  
LITERATURE REVIEW

*different applications in transmission line protection including fault detection, fault location, distance and direction detection, auto-reclosing, etc. The neural networks based protection scheme arranges the voltage and current signal samples as a pattern. The fault detection issues then become the pattern recognition issues. The advantage of neural network based protection scheme is its “intelligence” to find the internal similarity of different types of disturbances. The decision is made by measuring the similarity between the unknown patterns and the trained prototypes instead of comparing the characteristics of unknown patterns to the fixed relay settings. The disadvantage of this system is that one must train the network with a large data set, and one must select enough relevant training scenarios to be adaptive to the system” [57-62].*

*4) “In recent years, the concept of the “Transient Based Protection” is introduced by using fault generated high frequency transients to develop new relaying principles [63–68]. The technique detects high frequency transient signals through specially designed transducers and algorithms, thereby, overcoming the bandwidth limitation of conventional transducers. There are a few applications using the fault generated transient signals in transmission line protections developed so far. Although it is still not proven that this kind of method is reliable when high frequency disturbance in the signal is introduced, it is very attractive to explore significant improvement in terms of speed and new protection principle” [63-68].*

*“Although new protection schemes have been studied for a while, the conventional transmission line relays are still widely used in practice today. At the theoretical level, the new relay principles must be superior to the traditional relays in order to be used as a substitute. At the practical level, the design of the new relay principles considers the state-of-art computer and signal processing technology. As the digital relays are more widely used, the new relay principles are expected to be applied in the future. Although a lot of new techniques proposed in previous literature can provide an overall enhancement over the traditional relay, it is still hard to find a perfect match due to the algorithm or hardware limits. A combination of different techniques might be a better solution to achieve a high performance and simplify the real time decision making. The existing network and solutions for*

*preventing cascading blackouts do not propose new relay principles. Most of the schemes depend on the improvement of distance relay principles, setting and coordination. To solve BC's problems in preventing cascading blackouts, one can suggest some new protection schemes to be installed in the monitoring mode as the operation verification tool for existing distance relays. The improved fault analysis and load flow analysis results can be utilized to seek a better solution to reduce the impact of power interruptions. Currently, this kind of online application has not been implemented or even proposed. Most of fault analysis is implemented offline, which does not allow understanding the disturbances in real time" [63-68].*

## **2.6 Cost of reliability**

A decision concerning adequate levels of reliability and efficient provision determines the cost required for quality of supply to customers. In this section we discuss the main elements of this decision. We analyse the factors to be considered, the trade-offs involved, different alternatives are reported in sub-section 2.6.1. Reliability versus cost of interruption is expounded in sub-section 2.6.2. Cost effectiveness of reliability improvement in sub-section 2.6.3 and cost benefit analysis is reported in sub-section 2.6.4.

### **2.6.1 Customer interruption cost analysis**

*"System customer interruption cost analysis provides the opportunity to incorporate cost analysis and quantitative reliability assessment into a common structured framework, which can assist the decision making process. The highest level of efficiency can only be reached by comparing the increase of performance with the required investment costs. The assessment of expected performance indicators in respect to supply reliability is the task of the reliability assessment. This task can be divided into the calculation of non-monetary interruption indices and the calculation of reliability cost/worth indices. The calculation of non-monetary interruption statistics is more established [69-74]. One possible way to accommodate for customer importance is to use the costs for the energy not supplied (money/kWh) and/or a cost per interrupted power (money/kW) as an adjustable measure for interruption severity. This can produce useful indices, but it is often insufficient for more detailed planning or selection of alternatives. This*

IMPROVING BUFFALO CITY'S SUB-TRANSMISSION RELIABILITY  
LITERATURE REVIEW

linearization of the costs with the duration of the interruption does not consider the fast increase with duration that occurs for individuals as well as for aggregated loads [75]. An acceptable method of assessing the worth of power system reliability is to evaluate the customer losses due to service interruptions, i.e. the cost of unreliability [76]. The basic concept associated with power system reliability cost/worth evaluation is shown in Figure 2.11. The total public cost, which is ultimately borne by the customers, is the sum of the two curves. The optimum level of reliability occurs at the point, i.e. at the point of lowest total cost. Thus customer interruption cost (CIC) can be used as an estimate of the worth of reliable electric service. The customer survey approach, [75] in which customers are specifically contacted, is the most practical and reliable process to obtain these costs. Customer interruption costs are a function of both interruption and user characteristics. The costs incurred due to power supply interruptions can be presented as a function of outage duration, and when expressed in this form is known as a customer damage function (CDF). The CDF can be determined for a group of Customers belonging to particular standardized industrial classifications (SIC). In these cases, the interruption cost vs. duration plots are referred to as an individual customer damage functions (ICDF)" [77].

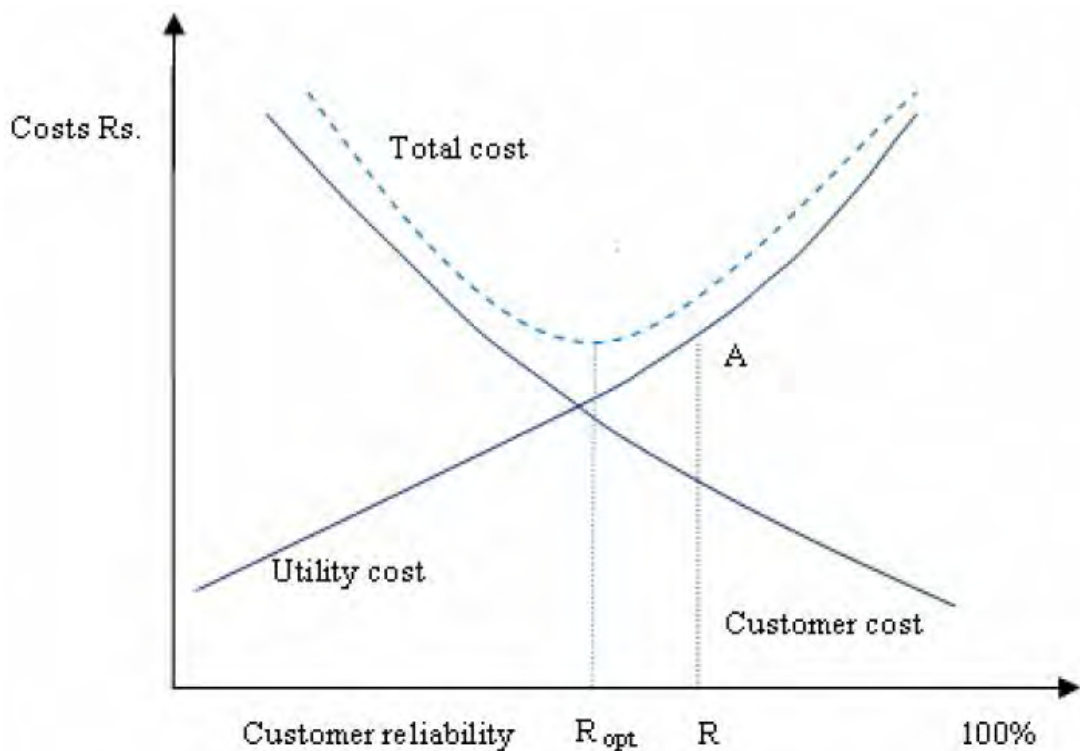

**Figure 2.11:** The basic concept associated with power system reliability cost/worth evaluation (adapted from [76])

### **2.6.2 Reliability versus cost**

*“The function of a power system is to supply electricity economically and with a reasonable assurance of continuity and quality. However, due to the integrated nature of power systems, failures in any part of the system can cause service disruptions. From the customer standpoint, power disruptions may be experienced as frequency and voltage reductions, as unstable supply with erratic frequency and power fluctuations or as a total interruption of supply. Although all these events impose costs on customers, in practice the effects of supply interruptions are the most severe. Ideally, supply should be made continuously available to customers, but that is costly and arguably not feasible. In fact, interruptions of supply are caused by power outages, which are predominantly events of stochastic nature involving the failure of one or several components in the system. Due to the random aspect of system failures, it is accepted that any system will present a definite risk of suffering a number of future power shortages. That is, unbalances between power supply and demand leading to load interruptions. The risk can be reduced by installing better equipment or by providing additional capacity as generation reserves. The reserve can be dispatched to replace lost generation, effectively reducing the probability of load curtailments.*

*Consequently, in order to lessen the effects of power shortages on customers, it is necessary to invest in installed capacity and to incur the operating costs of keeping reserves available. As generation reliability is improved, a trade-off occurs between the increased costs of capacity reserves and the increased benefits to customers, as avoided costs, from fewer power shortages. Therefore, when making decisions concerning adequate levels of generation reliability, the factors to consider are the incremental costs, the benefits expected and the allocation of capital and operating resources among the different parts of the system. The objective is to determine an optimal balance between the economic benefits of higher reliability and the corresponding costs” [77].*

### **2.6.3 Cost-effectiveness**

*“The traditional criterion in systems with centralized decision making has been to use least-cost resources in order to meet arbitrary levels of generation reliability. This sort of cost-effectiveness criterion implies a priority selection of a reliability level, usually based on experience and judgment. Gains realized from higher reliability are not considered. However, an increase in reliability may be advisable even if it results in a slight increase in cost, and a slight reduction in reliability may be acceptable if it results in significant savings. Accordingly, to reach an economically efficient outcome, the benefits gained by reliability improvements should be assessed against the costs of additional capacity” [77].*

### **2.6.4 Cost-benefit analysis**

*“A better approach compares the incremental cost of reserves with the corresponding decline in outage costs, that is, the economic costs incurred by consumers because of supply interruptions. The objective is to minimize investment and operating plus outage costs over the period considered. The point of minimum cost marks the optimal level of reliability to be used as a benchmark in the system. The method is illustrated in Figure 2.12. The investment and operating costs can be represented by curve RC, function of any suitable reliability index. Outage costs, represented by curve OC, decrease as reliability increases. The total cost curve TC is the sum of the individual cost curves RC and OC. Total cost presents a minimum at  $R^*$ , which determines the optimal level of reliability” [77].*

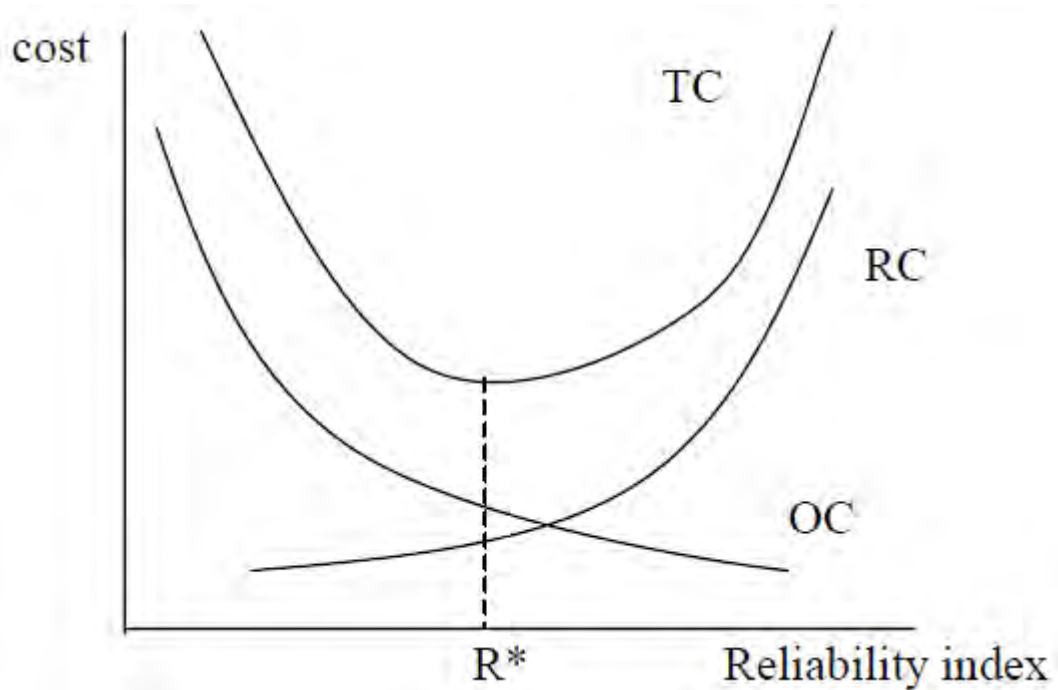

**Figure 2.12:** Total reliability costs (adapted from [77])

*“The reliability level  $R^*$  is treated as a variable and total social cost is minimized. This is equivalent to a cost-benefit analysis, which maximizes net social benefit. There are two difficulties in applying cost-benefit analysis. First, significant problems are found in assessing customer outage costs, and second, outage costs need to be related to an appropriate risk index used as measure of system reliability. Despite these difficulties, the cost-benefit analysis is a valid economic approach, but it is based on centralized decision-making. The cost-benefit approach does not incorporate individual choice being hardly compatible with competitive electricity markets, where suppliers decide individually the amount of capacity to commit” [77].*

## **2.7 Summary**

The review describe, summarize, evaluate and clarify the literature. It gives a theoretical basis for the research and helps to determine the nature of research. The aim of this section is to summarise the idea attained from past literature and to bring out contributions relevant for this study area. Thus this part starts with the knowledge gained in this research study and contribution to BCMM’s reliability improvement as follows.

### **2.7.1 Aging infrastructure equipment**

The general knowledge from the past literature is that there is a significant relationship between aging infrastructure equipment and reliability that could be evaluated with the use of bathtub method to determine failure rate, useful life and wear out period of the equipment. Reference [12] stated that as power system equipment continues to age and gradually deteriorates the probability of service interruption due to component failure increases. Therefore, the upkeep and refurbishment of aging equipment abate the failure rate to improve reliability

### **2.7.2 Non-responsiveness of protective relay**

The significant relationship between non-responsiveness of protective devices and reliability is clearly emphasized in the literature review. The theoretical understanding is that protective devices are made to be responsive to signals received in communication with relative devices to fulfil its role in reliability performance. Reference [20, 21] stated clearly that relay reliability considerations are usually separated into two different aspects of dependability and security. For protective device to be responsive in operation, it must fulfil both requirements of dependability and security. Modern technology such as Markov model can successfully achieve these requirements to enable protective relay responsiveness to meet its reliability obligation. Thus, there is strong relationship between non-responsiveness and reliability performance.

### **2.7.3 Reactive maintenance**

It has been proven that “perceived planned preventative maintenance (PPM) is a component of reliability improvement”. The results of effective PPM can decrease the number of outages and shortened outage times, and provide better quality of electricity service [7]. It is perceived that, selection of maintenance strategy is vital, however, one strategy may not fulfil maintenance needs of all equipment on the network. Thus, the selection of maintenance strategy has to be made for every component type. Maintenance optimised equipment life cycle, safe operations, increase performance, and to mitigate or eliminate system interruptions and equipment breakdown. An analysis throughout the world shows that 90% of all customer reliability problems are due to the problems in distribution system. Thus,

improving reliability on sub-transmission distribution system is the key to improving customer reliability satisfactory [11]. And therefore, choosing relevant maintenance strategy is vital for the contribution to customer reliability satisfaction.

The questions that arose from this conclusion 'is that, is there a significant relationship between aging infrastructure equipment and reliability?' 'Is there a significant relationship between relay failures and reliability?' and 'is there a significant relationship between reactive maintenance and reliability?' The importance of these significant relationships will assist us for reliability improvement.

#### **2.7.4 Cost of customer reliability**

The cost of customer interruptions is vitally important to be determined on utility network. It provides necessary information to determine cost of reliability performance. Analysis of customer interruption cost (CIC), customer damage cost (CDC), customer damage function (CDF) makes an informed decision to determine the cost of customer reliability. The CDF can be determined for a group of customers belonging to particular standardized industrial classifications (SIC). In these cases, the interruption cost versus duration plots are referred to as an individual customer damage functions (ICDF). Cost benefit analysis aims to minimize the investment, operating and outage cost for pre-determine period. The idea is to minimize the cost to optimal reliability level as a benchmark to be used in the network system. This clearly indicates that, reliability cost has significant relationship for improvement of power system reliability.

IMPROVING BUFFALO CITY'S SUB-TRANSMISSION RELIABILITY  
LITERATURE REVIEW

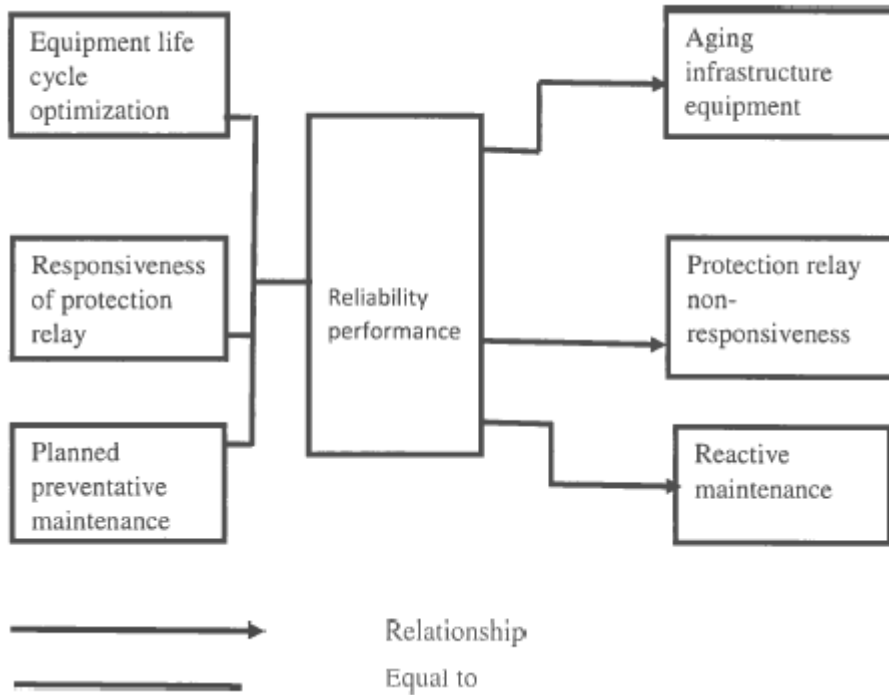

**Figure 2.13:** The relationship between reliability and aging infrastructure, relay failures and reactive maintenance for this study.

If the above is agreed that infrastructure equipment life cycle optimization, responsiveness of protective relay, planned preventative maintenance and cost of reliability are satisfied and give the reasons for satisfaction as reliability performance then, conclusion should be drawn that reliability performance has a significant relationship with aging infrastructure equipment, non-responsiveness of protective relay, reactive maintenance and unreliability can result in lower reliability. Based on these significant relationships, the research questions are validated on the fact that reliability has a significant relationship with service quality essentials which can affect reliability negatively or positively.

## CHAPTER 3: AN OVERVIEW OF BC'S SUB-TRANSMISSION NETWORK

This chapter provides an assessment based on current state, utility source and experienced blackouts, which are selected for review and identifies key topics in which more information and theory might be useful as subjects from the literature review. It also provides a clear description of the problems experienced and group them into categories in order to demonstrate capability in situation analysis.

### 3.1 Introduction

Electric power systems are often divided conceptually into three main sub-systems: generation, transmission and distribution. Transmission systems have the responsibility of supplying electric energy to distribution units, where most electric consumers are located. Since delivery of electric energy to consumers is the aim of electric systems, it is vital importance to focus on the operation of the transmission unit. Figure 3.2 shows Buffalo City's existing sub-transmission network, dating back to 1972. Figure 3.1 depicts the area map showing the route length of the 132 kilovolt (kV) network grid from Stafford switchyard to Stoney Drift and Progress substations respectively.

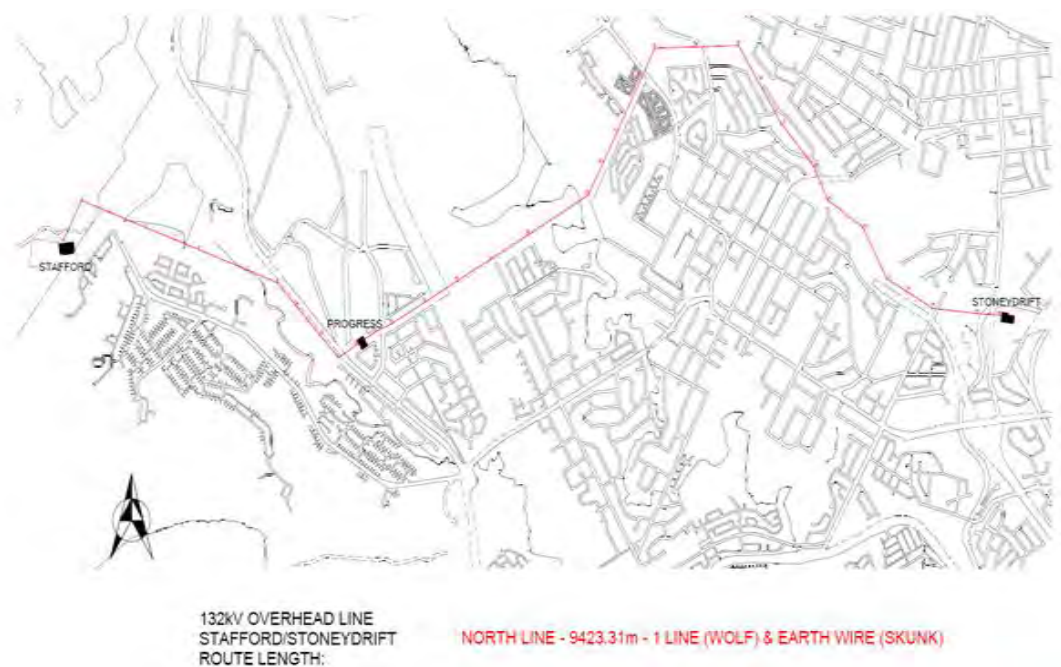

**Figure 3.1:** 132 kV Stafford/Stoney Drift/Progress overhead line route length

The system connects from Buffalo City Metropolitan Municipality's (BCMM's) point of supply, where power is taken from Eskom and is then transmitted to various main substations owned and operated by BC. Numerous incidents have occurred in Chiselhurst (adjacent Stoney Drift substation) and Progress substations and in each case the entire supply to BC was interrupted. It is convenient for this research to describe the following component of the system as essential background to analysing the incidents and the causes of blackouts.

The intake switching station (Stafford switchyard), which receives supply from the adjacent Eskom (Buffalo) substation. Two main BC substations, Stoney Drift and Progress are the hubs of the distribution network. The maximum current carrying capacity of the line is 500 amps. An Eskom 66 kV line (which serves as redundancy supply intake) is a back-up capability to meet the needs of supplying BC. The line between Eskom's Aloe Glen and Buffalo substations is a Bear conductor with maximum current carrying capacity of 541 amps. The intake circuit breakers protecting these 132 kV and 66 kV transmission systems are situated in Eskom's Buffalo substation.

### **3.2 Main source of supply**

The bulk power for Buffalo City is transmitted by Eskom from Hydra 400 kV substation to Delphi 400 kV substation near Queenstown and to Neptune 400 kV substation near East London. Neptune substation has 2 x 500 MVA, 400/132 kV transformers. Two 132 kV lines approximately 12 km long, supply Eskom's Buffalo substation.

Eskom's Aloe Glen substation is also supplied from Delphi substation near Queenstown and has 2 x 80 MVA, 132/66 kV transformers. One 66 kV transmission circuit is 12.5 km long, and supplies Eskom's Buffalo substation. The BC's line between Stafford and Stoney Drift via Progress substations has current carrying capacity of 500 amps. The 66 kV transmission line has 541 amps, the current carrying capacity available to supply Buffalo City without constraint at

IMPROVING BUFFALO CITY'S SUB-TRANSMISSION RELIABILITY  
AN OVERVIEW OF BC'S SUB-TRANSMISSION NETWORK

Eskom's Buffalo substation in the event of losing supply on the 132 kV line. This implies that, there is N-2 reliability available in Eskom's Buffalo substation for BC to take advantage of improving reliability.

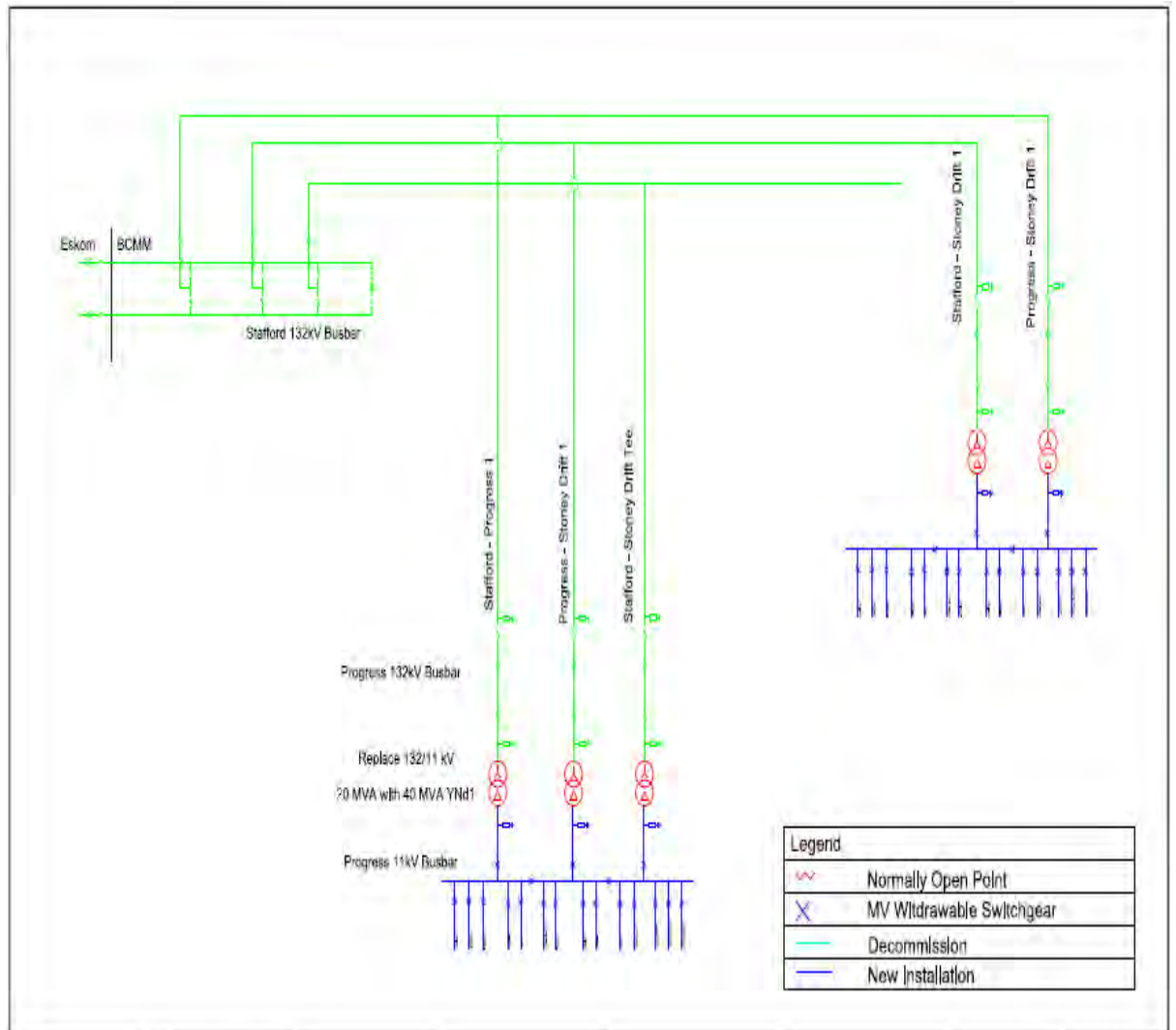

**Figure 3.2:** Existing BC's sub-transmission network

### 3.3 Main equipment

The power systems main equipment are indispensable for the functionality of the sub-transmission system. These equipment ranges from overhead lines, power transformers, substations, switchgears etc. It is imperative to take into account the reliability of the main equipment of the sub-transmission systems.

### 3.3.1 Overhead lines

BC's HV network consists of a double circuit and single circuit 132 kV lattice tower lines, emanating from Stafford switchyard and terminating at Stoney Drift substation. A tee-off into Progress substation supplies power to the Western part of the Metropolitan. Figure 3.3 below shows BC's sub-transmission HV lines from Stafford and Progress tee-off 132 kV feeders. The distance from Stafford to Progress tee-off is approximately 3 km. The conductor type of the 132 kV overhead line is Wolf conductor.



**Figure 3.3:** Stafford-Progress tee-off 132 kV feeders.

### 3.3.2 Substations and transformers

Stoney Drift substation is the receiving end from the Stafford switchyard feeders via Progress substation. The Progress substation tee-off is between Stafford and Stoney Drift, and has 3 x 132/11 kV 20 mega-volt ampere (MVA) transformers with neutral earth compensators (NECs) to give a sufficient current for selective earth fault protection. The 132/33 kV Stoney Drift substation is one of the main distribution centres of the system including the central business district (CBD).

IMPROVING BUFFALO CITY'S SUB-TRANSMISSION RELIABILITY  
AN OVERVIEW OF BC'S SUB-TRANSMISSION NETWORK

This substation consists of 2 x 90 MVA, YNyn0, 132/33 kV transformers with NECs to generate a current sufficient for selective earth fault protection on the transformers. Stoney Drift also has 3 x 33/11 kV, YNd1 transformers for further distribution.

**Table 3.1:** Substations and transformers

No	Power Transformer	Quantity	Voltage	Capacity
1	Stoney Drift substation	2	132/33 kV	90 MVA
2	Progress substation	3	132/11 kV	20 MVA
3	Chiselhurst substation	3	33/11 KV	16 MVA

### 3.3.3 Circuit breakers

Circuit breakers are mechanical switches and protection devices that electrically isolate circuits and components under normal operating conditions, or automatically under emergency situations such as sustained faults. The command to isolate the circuit is usually provided by protective relays. BC's sub-transmission network utilizes 132 kV oil circuit breakers; two circuit breakers are situated in Stafford switchyard, sixteen circuit breakers in Stoney Drift substation and six circuit breakers in Progress substation. The main equipment of lines, substations, transformers, switchgears (circuit breakers) etc., are elaborated to clarify the main system parameters on the BC's sub-transmission network. The diagram below shows the number of main circuit breakers on the sub-transmission network. Figure 1.1, Figure 3.4 and Figure 3.8 clearly indicates the number of circuit breakers in the respective substations. Figure 3.4 depicts the Stoney Drift switchyard arrangement with sixteen circuit breakers.

**Table 3.2:** BC's sub-transmission circuit breakers

No	Circuit breaker	Type	Quantity
1	Stafford switchyard	Oil	2
2	Progress substation	Oil	6
3	Stoney Drift switchyard arrangement	Oil	16

IMPROVING BUFFALO CITY'S SUB-TRANSMISSION RELIABILITY  
AN OVERVIEW OF BC'S SUB-TRANSMISSION NETWORK

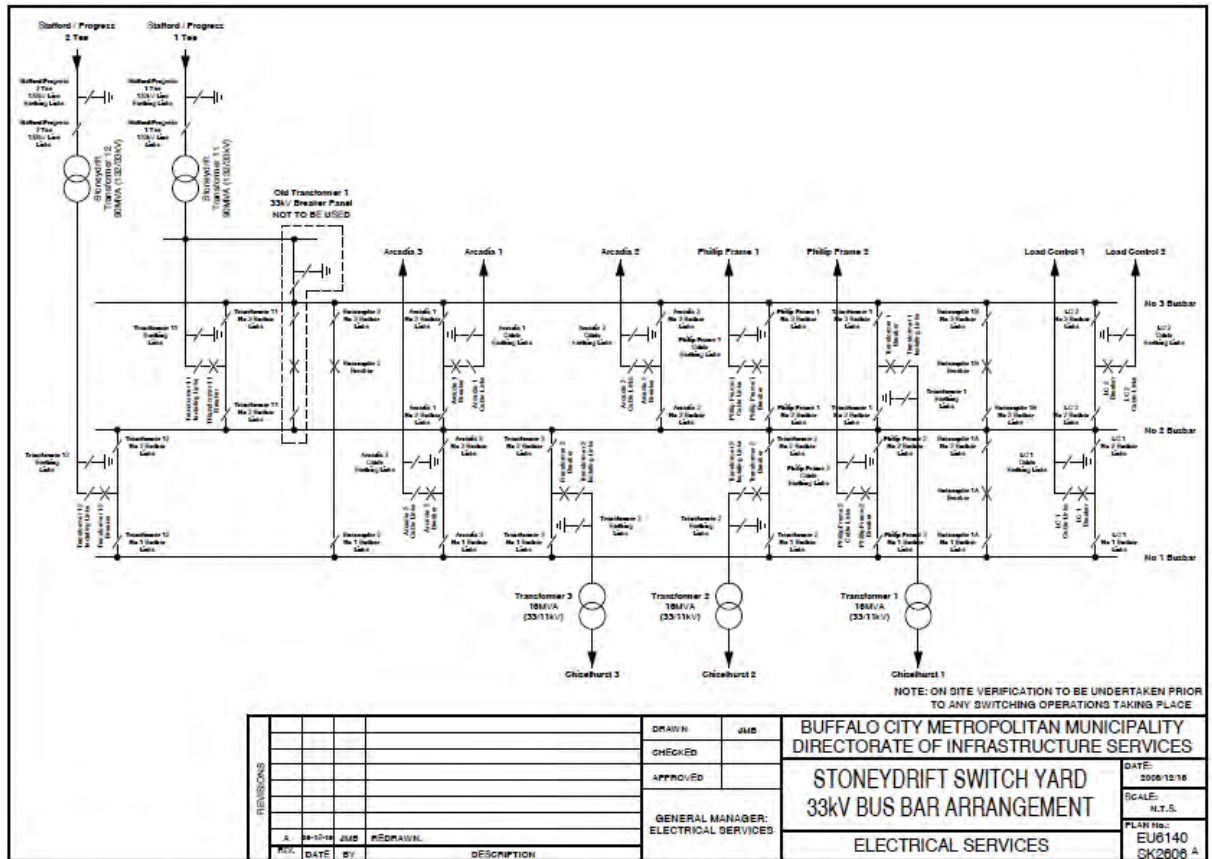

**Figure 3.4:** Stoney Drift HV/MV switchyard arrangement with sixteen circuit breakers.

### 3.4 Protection scheme review

The sub-transmission protection systems are designed to identify the location of faults and isolate only the faulted section. The key challenge for transmission line protection lies on reliably detecting and isolating any faults compromising the security system. The most essential factors of the protection system must directly address dependability and security, the type of communication available, type of relays, the age of the system and also its condition. Since Buffalo City's sub-transmission network dates back to 1972 (all three circuits), it implies that the network's protection system is equally as old as the transmission network. The protection scheme installed on the network is known as a pilot protection scheme. Such scheme uses communication channels to send information from the local relay terminals to the remote relay terminal, thereby allowing high-speed tripping for faults occurring within 100% of the protected line. The pilot wires of the

**IMPROVING BUFFALO CITY'S SUB-TRANSMISSION RELIABILITY  
AN OVERVIEW OF BC'S SUB-TRANSMISSION NETWORK**

protection scheme have been vandalized therefore, there is no protective relay communication between Stafford switchyard and Stoney Drift via Progress substations. This scenario might cause protection equipment failures and may result in blackouts. The effect of protection systems; relays failures, non-communication channels, age and condition are expounded in sections 3.6.1 and 3.6.2 to clarify the role the protection scheme plays in power system reliability. The design of operations, the principles of distance protection scheme design, the coordination and tuning or setting of relay to give a fast, reliable, sensitive and selective protection system is presented in Appendix C.

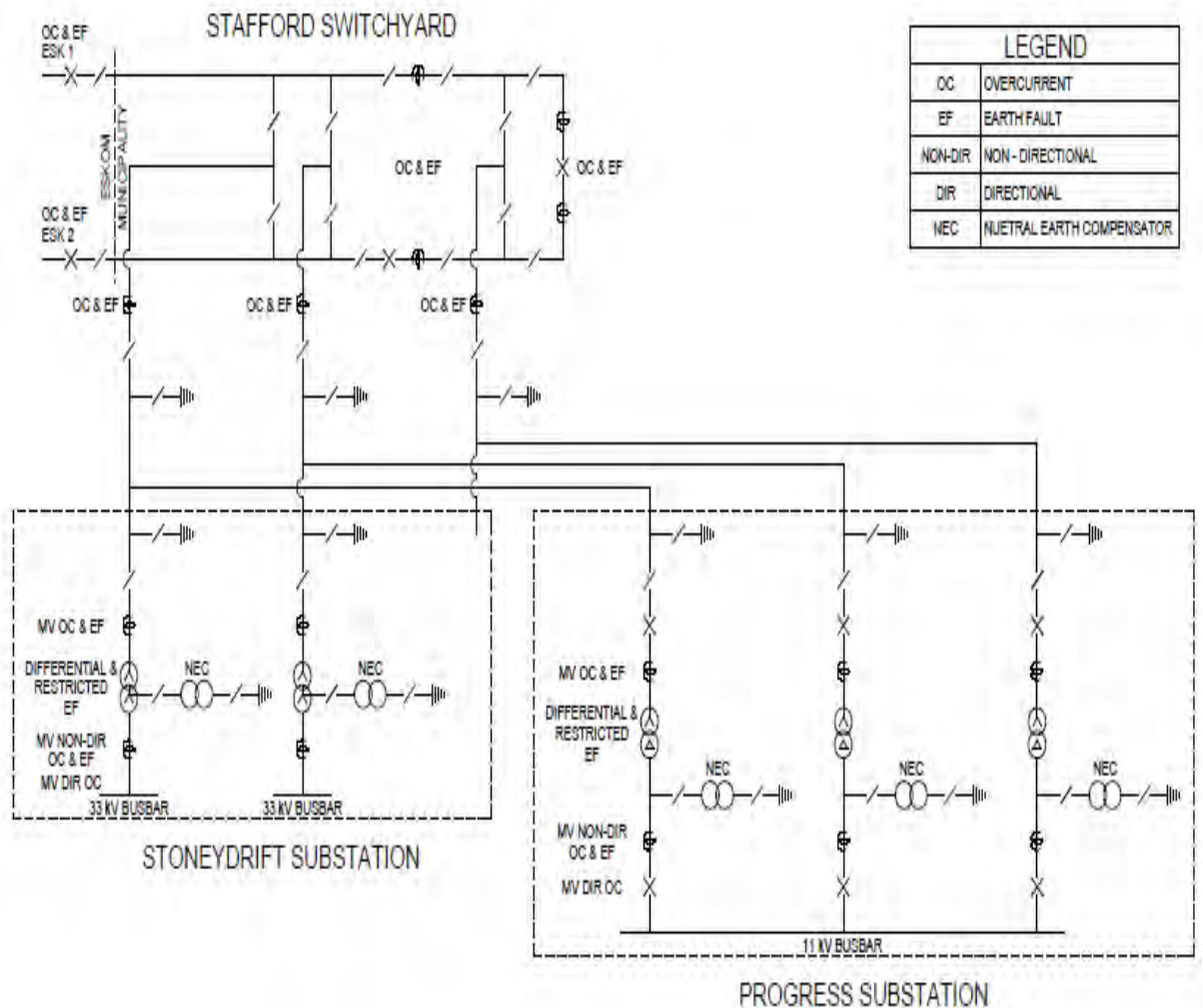

**Figure 3.5:** Single line diagram of the existing protection scheme

### **3.5 Network reliability problems**

The main network reliability problem is the total isolation (blackouts) of the sub-transmission network, including Stafford switchyard (utility source), Stoney Drift 132/33 kV and Progress 132/11 kV substations. Numerous network problems (regular interruptions) occurred over the previous six-year period. The nature of many persisting outages is often directly related to network reliability problems. The main concerns of the Stafford/Stoney Drift is the unreliability of the network, which may be caused by aging infrastructure, an absence of planned preventative maintenance and protection relay failures. This chapter provides an overview of the unreliability of the power supply, which is unacceptable to consumers who expect to pay for reliability particularly commercial and industrial customers. Sections 3.6.1 and 3.6.2 highlights the blackout incidents that happened in Chiselhurst (adjacent Stoney Drift substation) and Progress. These highlight the need for improving reliability of the affected power supply.

#### **3.5.1 Categorisation of problems**

Electrical infrastructure begins to deteriorate once it is built or installed. Systems, techniques and methods are to be developed to upkeep equipment life cycle. The following description aims to group the problems experienced on BC's sub-transmission network in order to analyse the situation.

##### **3.5.1.1 Aging infrastructure**

The aging infrastructure, which comprises of components such as power lines, cables, circuit breakers, switches, transformers and protection scheme relays, current transformers (CT's), voltage transformers (VT's), pilot wires etc., were installed in 1972. The performance and life expectancy of the electrical systems started to decline due to environmental conditions, such as weather, overload conditions, and excessive duty cycles right from their inception. Aging infrastructure in BC's network becomes vulnerable to breakdowns. Due to such aging, the down time of restoring electricity supply to customers also increases. This scenario affects both system reliability and customer satisfaction. Aging infrastructure poses a risk of equipment breakdowns, unsafe switching on and off

of the switchgears and regular power outages. This research investigates the situation and analyses the best possible way for infrastructure optimisation.

#### **3.5.1.2 Protection relay failures**

Protection schemes exist 'behind the scene' for power system to operate effectively and reliably. Protection schemes are the control part of electrical power system functionality. These schemes comprises component such as CT's, VT's, relays, communication wires etc. Relays are components that command circuit breakers for disconnection of power flowing through the circuit in the event of a fault on the electrical network. Relay failures of protection schemes jeopardise power system reliability. Therefore, it is imperative for this research study to review the relevant literatures in order to analyse these events.

#### **3.5.1.3 Maintenance strategy**

Maintenance of sub-transmission networks is paramount for continuity of supply to associated customers. Electrical power infrastructure begin to deteriorate soon after its installation. Deterioration causes component deficiency and affects performance therefore, it's imperative to be able to select a relevant maintenance strategy to enhance the operational capability of the network systems. Two well-known maintenance strategies are classified as reactive and preventative maintenance respectively; reactive entails failure before maintenance and preventative on the other hand entails maintenance before failure. Currently BC is utilising the reactive maintenance strategy which, does not provide any improvement to the infrastructure life cycle; rather, deterioration steadily continues as the infrastructure continues aging. A planned preventative maintenance strategy on the other hand optimises the infrastructure life cycle and renders equipment available for use. A literature review is imperative, in order to identify a relevant strategy in this regard, specific to BC, which is vital to curb this situation.

#### **3.5.1.4 Blackouts**

Blackouts are unplanned and unwanted events that affect all walks of life within that particular network supply vicinity. It affects domestic, commercial and industrial consumers as well as the city at large. A blackout is the total isolation of

IMPROVING BUFFALO CITY'S SUB-TRANSMISSION RELIABILITY  
AN OVERVIEW OF BC'S SUB-TRANSMISSION NETWORK

the entire sub-transmission network from the intake point of supply due to some downstream fault that have been occurred. In 2006, for example, major disturbances occurred at the Chiselhurst switch house (adjacent Stoney Drift substation) in Buffalo City, specifically the East London area of supply. Two years later in 2008, another blackout happened in Progress substation. These catastrophic incidents highlights the need for research to investigate the root cause of such problems. Mitigation of the probability of future total supply interruption (blackouts) is called for by the community.

### **3.6 Case study based on experienced blackouts**

Several substantial supply disruptions involving a failure of network services occurred in BC during 2006 and 2008. This section reviews the major disturbances that have occurred within the past decade in BC, specifically between 2004 and 2010. These two major events are featured in the following case studies as case study 1 and 2 below.

#### **3.6.1 Case study 1 (Blackout of 18<sup>th</sup> March 2006)**

The largest supply interruption in BC's history struck at around 11:45 a.m. on 18<sup>th</sup> of March 2006. It affected the entire East London areas of power supply. This event had two distinct phases. It began with a combination of failures and system operated simultaneous in Chiselhurst switch house between 11:15 a.m. and 11:45 a.m., which led to the progressive tripping of key 132 kV lines between Stafford switchyard and Progress /Stoney Drift substations.

There are 3 x feeder cables supplying power to Vincent Park suburb namely Vincent 1, 2 and 3 feeders respectively. The event began with the Vincent No. 3 feeder cable which had previously faulted between Chiselhurst and Vincent switch houses. The remaining two feeders had to be closed to supply power to Vincent switch house. In order to prevent overloading in either of the two feeders to Vincent switch house, their circuit breakers were evidently operated simultaneously.

The simultaneous closure of Vincent No. 1 and Vincent No. 2 circuit breakers at the Chiselhurst switch house triggered Vincent No. 1 circuit breaker to develop a

**IMPROVING BUFFALO CITY'S SUB-TRANSMISSION RELIABILITY  
AN OVERVIEW OF BC'S SUB-TRANSMISSION NETWORK**

fault on the feeder side of the breaker and tripped correctly. The event was sustained via the Vincent No. 2 cable as the bus section switch was closed at the Vincent switch house. A 30 seconds period during which Vincent No.2 circuit breaker in Chiselhurst switch house fail-to-trip, a rattling noise was heard in Vincent No. 2 circuit breaker in Chiselhurst switch house. The three switch board circuitry exploded that caused major damage to one section of the board including relays in the switch house. The second phase of the event occurred as the fault escalated into the 33/11 kV switchyard with busbar fault developed after a period of about 30 minutes during which 33 kV circuit breakers failed-to-trip. The protection systems failure to operate quickly enough and selectively in a presence of a fault, the fault escalated to trip the infeed circuit breakers situated in Eskom's Buffalo substation. Figures 3.6a, 3.6b and 3.7 depicts Chiselhurst switch house system diagrams (sheet 1& 2) and Vincent Park system diagram respectively.

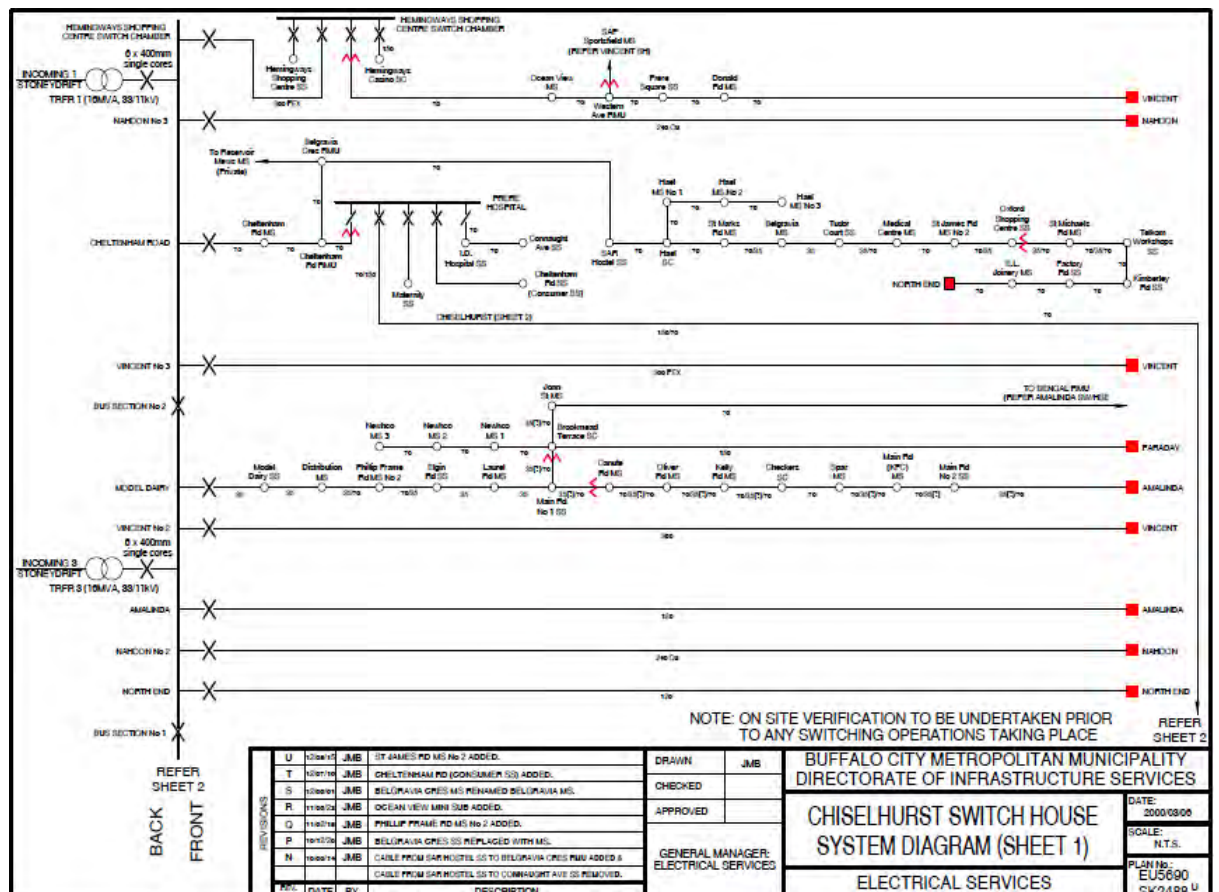

**Figure 3.6a:** Chiselhurst switch house system diagram (sheet 1)

IMPROVING BUFFALO CITY'S SUB-TRANSMISSION RELIABILITY  
AN OVERVIEW OF BC'S SUB-TRANSMISSION NETWORK

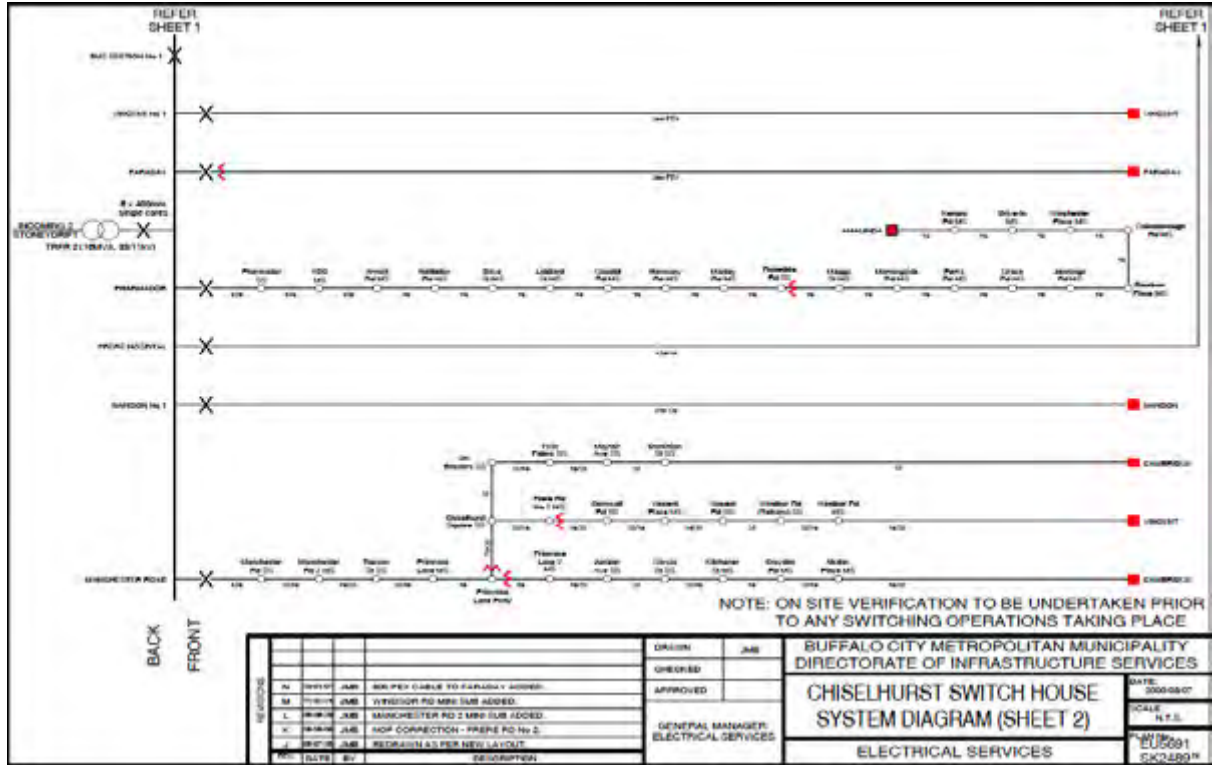

Figure 3.6b: Chiselhurst switch house system diagram (sheet 2)

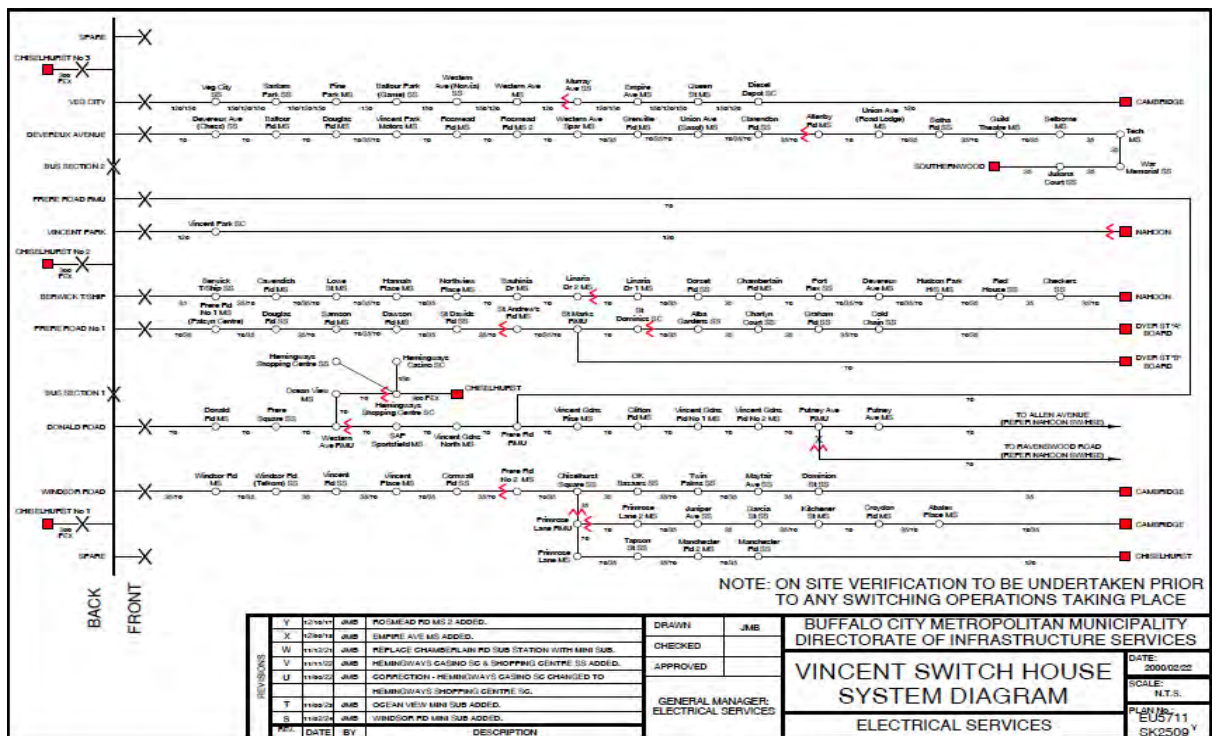

Figure 3.7: Vincent Park switch house

### **3.6.1.1 Impact from the outages**

Once the 132 kV circuit breakers tripped, large portions of East London was disconnected. The failure impacted on industrial, commercial and domestic customers as well as education systems in the City. The load lost was estimated to be 192 MVA in the East London. The economic cost of the disruption has been estimated at between R8 million and R10 million during the outage period. Hundreds of working hours lost and manufacturing production was down. The blackout caused inconveniences to everyone in the City.

### **3.6.1.2 Restoration process**

Most services were restored in the areas supplied from Progress substation within 6 hours, with all services fully restored within forty-eight hours. Restoration proceeded in accordance with established contingency with service providers (contractors) available on the database. Restoration was greatly assisted by the contractors with the ability to energize sub-transmission network from Stafford to Stoney Drift and Progress substations. Progress substation formed the basis for restoration in the North East part of Buffalo City. Mobile substation was installed after the event allowing relatively quick restoration of many suburbs as possible and the entire City at large.

### **3.6.2 Case study 2 (Blackout of 11<sup>th</sup> January 2008)**

East London worst supply disruption in 2 years struck on 11<sup>th</sup> January 2008 after Chiselhurst blackout. The system failure occurred due to the explosion of a current transformer (CT) in Progress substation, which triggered the tripping of the 132 kV breakers situated in Eskom's Buffalo substation. The failure of the CT occurred about 12:30 p.m. The circumstances surrounding the explosion is summarized as follows:

The event started at around 12:30 p.m. on 11<sup>th</sup> January 2008, a current transformer at the Progress substation in Wilsonia Industrail Park developed an internal fault causing it to later explode. This failure triggered a major power disturbance in the East London. The 132 kV CT on the blue phase of transformer No. 2 unexpectedly exploded. Insulators on the 132 kV line link isolators were extensively damaged, the HV surge arrestors on the red, white and blue phases of the 132 kV incomer

**IMPROVING BUFFALO CITY'S SUB-TRANSMISSION RELIABILITY  
AN OVERVIEW OF BC'S SUB-TRANSMISSION NETWORK**

No. 2 to the substation were also damaged. The 132 kV circuit breaker insulators sustained damages to all the three phases and the bushing on white phase of the transformer No. 2 were also damaged by flying debris.

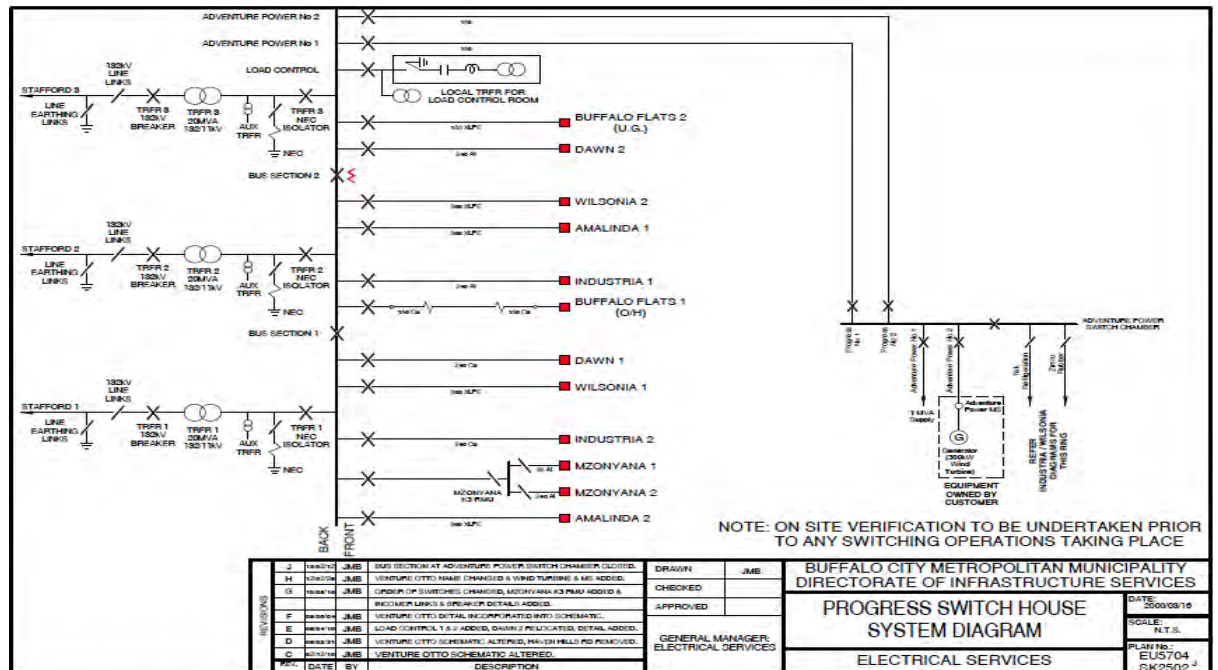

**Figure 3.8:** Progress substation: HV arrangement with six circuit breakers

The reasons for the CT explosion cannot be accurately determined, as there is no positive evidence as to where or how the fault originated. No tests can be carried out on the CT as it has been totally destroyed. Possible reasons for the fault are detailed below:

- A direct lightning strike on the busbars causing an overvoltage to the system;
- Possible vandalism (Insulator shot)
- Low or no oil in the CT, Oil is the insulating medium within the unit. (This cannot be determined as the CT was completely destroyed);
- Water ingress, Moisture ingress usually takes place in the top gasket;
- Pollution on the CT insulator (This could be anything from a plastic packet to dirt on the insulator); and
- A loose connection on the HV connector to the CT (This cannot be determined as the CT was completely destroyed).

IMPROVING BUFFALO CITY'S SUB-TRANSMISSION RELIABILITY  
AN OVERVIEW OF BC'S SUB-TRANSMISSION NETWORK

The No 2 infeed circuit breaker failure 'to clear the fault' could be one of the following reason; either the circuit breaker was not tripped by the protection relay, or the circuit breaker was damaged and could not operate, or the circuit breaker operated but did not clear the fault because there was flashover across the breaker or on other parts of the substation upstream of the circuit breaker. The fault escalated to trip the infeed circuit breakers situated in Eskom's Buffalo substation which results in blackout. The impact and restoration of the Progress substation blackout is similar to that of the Chiselhurst switch house. Sections 3.6.1.1 and 3.6.1.2 elaborates these process in details.

## **CHAPTER 4: LOAD FLOW STUDY ON BC'S NETWORK**

A planned and effective distribution network is the key to cope with the ever increasing demand for domestic, industrial and commercial loads. The load-flow study of sub-transmission distribution network is of prime importance for effective planning of load transfer. The purpose of this load flow is to analyse and compute accurate steady state voltages of all sub-transmission and distribution sections in the network. Also it gives the necessary data needed to confidently plan improvements to existing network and justify the recommendation of this study.

### **4.1 Introduction**

This study uses DIgSILENT Power Factory load flow model to pinpoint problems in existing sub-transmission network and determine the effects on the reliability performance. Load flow analysis (LFA), is the most important tool used in power system analysis, design and planning. It is an essential tool, power utilities use for planning, operating, efficiency and power exchange. Load flow is also necessary for other network situations, for instance, transient stabilities or for contingency scenarios. LFA is essential when determining the capability of a distribution network under different network configuration and loading conditions. A typical report of the LFA should accommodate the losses of various parts of the network such as: infeed power sources whether generated within the network or transformer substations; infeed obtained from higher voltage network. This chapter will be using DIgSILENT Power Factory simulation of the existing sub-transmission main equipment (132/33 kV, 90 MVA, YNyn0 and 132/11 kV, 20 MVA, YNd1 transformers) and alternative (1) sub-transmission equipment (132/11 kV 40 MVA, YNd1 and 132/11 kV 20 MVA, YNd1 for Stoney Drift and Progress substations respectively). Selection between the two transmission models will inform quality decision making.

### **4.2 Sub-transmission model**

“DIgSILENT Power Factory is very flexible power system analysis software, and it has a very wide range of modelling features in terms of transmission lines. DIgSILENT Power Factory provides models from direct current (DC) to alternative current (AC) lines over all possible phase technologies (3ph, 2ph and

IMPROVING BUFFALO CITY'S SUB-TRANSMISSION RELIABILITY  
LOAD FLOW STUDY ON BC'S NETWORK

single phase, with/without neutral conductor and ground wires) for both single circuit and mutually coupled parallel circuits. Table 4.1 shows an overview of all supported options and the corresponding element/type combination. The line element, *ElmLne*, is the most basic branch elements, and it is used to represent the model of the overhead transmission lines. The line element can be used to define single-circuit lines of any phase technology according to Table 4.1" [78].

**Table 4.1:** Overview of line models as available in Power Factory [78]

System	Phase Technology	Element	Type
DC	Unipolar	<i>Elmlne</i>	<i>Typlne</i>
AC, single circuit	1-ph	<i>Elmlne</i>	<i>Typlne</i>
	2-ph	<i>Elmlne</i>	<i>Typlne</i>
	3-ph	<i>Elmlne</i>	<i>Typlne, Typlne, TypGeo</i>
	1-ph with neutral	<i>Elmlne</i>	<i>Typlne</i>
	2-ph with neutral	<i>Elmlne</i>	<i>Typlne</i>
	3-ph with neutral	<i>Elmlne</i>	<i>Typlne</i>
AC, mutually coupled circuits	Any combination of phase technologies	<i>ElmTow</i>	<i>TypTow, TypGeo</i>

For three-phase lines (either single or multiple parallel circuits), the user can choose between two different types of models: existing or alternative (1) models.

A transmission line is defined as a short-length line if its length is less than/or 80 km. In this case, the shunt capacitance effect is negligible and only the resistance and inductive reactance are considered, and a model based on existing network can be used without any prejudice of the results. The route length of the BC's sub-transmission line network is 10 km and it's classified as short transmission line. In the short line model shown in Figure 4.1, this dissertation assumes the shunt capacitance (the legs of the  $\pi$ ) are so small that they are open circuit (i.e. neglected). This leaves only the series RL branch.

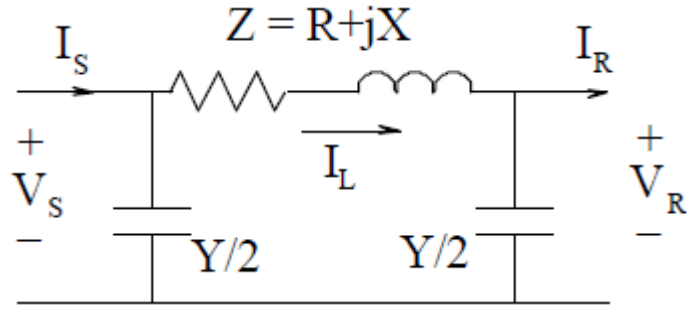

**Figure 4.1:** Short line model as a “Pi” section with lumped parameters (adapted from [79])

A short line with a load is shown (per phase) in the Figure 4.2. Using circuit theory we have:

$$I_R = \frac{S_R^*}{V_R^*} \quad (4.1)$$

$$V_S = V_R + ZI_R \quad (4.2)$$

Note that  $I_S = I_R$ . Now, to find the transmission parameters (or ABCD parameters) of the short line:

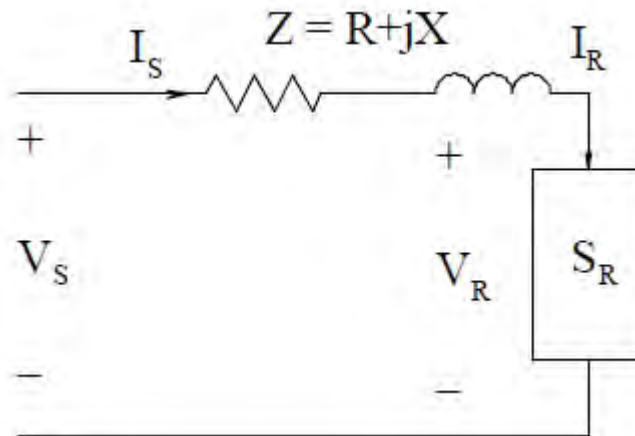

**Figure 4.2:** Short line with load (adapted from [79])

For a 2-port model shown in Figure 4.3 as "ABCD" the equations are as follows:

$$\begin{bmatrix} V_S \\ I_S \end{bmatrix} = \begin{bmatrix} A & B \\ C & D \end{bmatrix} \begin{bmatrix} V_R \\ I_R \end{bmatrix} \quad (4.3)$$

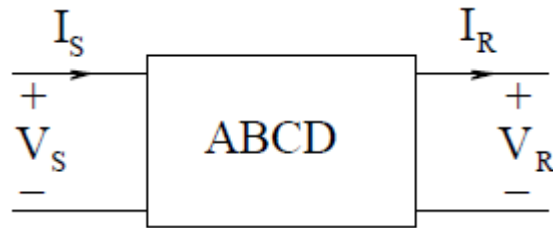

**Figure 4.3:** Short line 2-port model (adapted from [79])

Comparing with the equations for the short line above,  $A = 1$ ,  $B = Z$ ,  $C = 0$  and  $D = 1$ . This completes the equations needed to represent the short line.

### 4.3 Existing network simulation

LFA of the sub-transmission system is conducted using DIgSILENT Power Factory version 15.2. It is possible to define any type of fault at any location such as the substations, overhead lines or the AC network feeding the substations using this software. Therefore, the stability and the reliability of this sub-transmission system can be investigated. In order to perform a load flow study, full data is collected about the area of study on the network, such as network diagrams, transformer parameters and overhead lines, rated values of each main equipment etc. Table 4.2 shows data collected on the overhead line of study between Stafford/Stoney Drift and Progress substations. Table 4.3 and Table 4.4 shows data collected on the sub-transmission transformers and tap changers in Progress and Stoney Drift. The line data, transformer data and tap changer data required for simulation of the network are shown below.

- **Line type data (TypLne)**

**Table 4.2:** Line type data for Stafford/Stoney Drift/ Progress line

Name	Rated Voltage kV	Rated Current kA	Cable/ OHL	R (20°C)	X'	RO'	XO'	B'	BO'	Conductor
ACSR Single Wolf	132	0.470	OHL	0.208	0.401	0.308	0.501	0.353	0.353	Aluminum

IMPROVING BUFFALO CITY'S SUB-TRANSMISSION RELIABILITY  
LOAD FLOW STUDY ON BC'S NETWORK

• Transformer type data (TypTr2)

**Table 4.3:** Transformer type data 1

<b>Name: 132/11 kV 20MVA YNd1 16 Step 5 Nom</b>							
<b>Rated Power</b>	<b>HV Rated Volt</b>	<b>LV Rated Volt</b>	<b>Z</b>	<b>Cu losses</b>	<b>Vector Group</b>		
MVA	kV	kV	%	kW			
20	132	11	15.35	47	YNd1		
<b>Tap Side</b>	<b>Add.V/tap</b>	<b>Phase of du</b>	<b>Neu Tap</b>	<b>Min. Tap</b>	<b>Max. Tap</b>	<b>No load current</b>	<b>No load loss</b>
	%	Deg				%	kW
HV	1.25	180	7	1	16	0	0
<b>Tap Dependant</b>	<b>Min Tap</b>	<b>Max Tap</b>	<b>Min tap Cu</b>	<b>Max tap Cu losses</b>			
	%	%	kW	kW			
Yes	10.5	8.9	53	39			

**Table 4.4:** Transformer type data 2

<b>Name: 132/33 kV 90MVA YNyn0 15 Step 5 Nom</b>							
<b>Rated Power</b>	<b>HV Rated Volt</b>	<b>LV Rated Volt</b>	<b>Z</b>	<b>Cu losses</b>	<b>Vector Group</b>		
MVA	kV	kV	%	kW			
90	132	33	15.4	47	YNyn0		
<b>Tap Side</b>	<b>Add.V/tap</b>	<b>Phase of du</b>	<b>Neu Tap</b>	<b>Min. Tap</b>	<b>Max. Tap</b>	<b>No load current</b>	<b>No load loss</b>

IMPROVING BUFFALO CITY'S SUB-TRANSMISSION RELIABILITY  
LOAD FLOW STUDY ON BC'S NETWORK

	%	Deg				%	kW
HV	1.25	180	8	1	15	0	0
<b>Tap dependant</b>	<b>Min Tap</b>	<b>Max Tap</b>	<b>Min tap Cu</b>	<b>Max tap Cu losses</b>			
	%	%	kW	kW			
Yes	10.5	8.9	53	39			

• **Tower geometry type data (TypGeo)**

**Table 4.5: Tower geometry type data**

<b>No. earth wires</b>	3						
<b>No. line/circuit</b>	3						
	<b>X</b>	<b>Y</b>					
<b>Earth wire 1</b>	-4.3	21					
<b>Earth wire 2</b>	4.3	21					
	<b>No. Phases</b>	<b>X1</b>	<b>X2</b>	<b>X3</b>	<b>Y1</b>	<b>Y2</b>	<b>Y3</b>
Circuit 3	3	1.7	1.7	1.7	2.5	2.3	1.85

## IMPROVING BUFFALO CITY'S SUB-TRANSMISSION RELIABILITY LOAD FLOW STUDY ON BC'S NETWORK

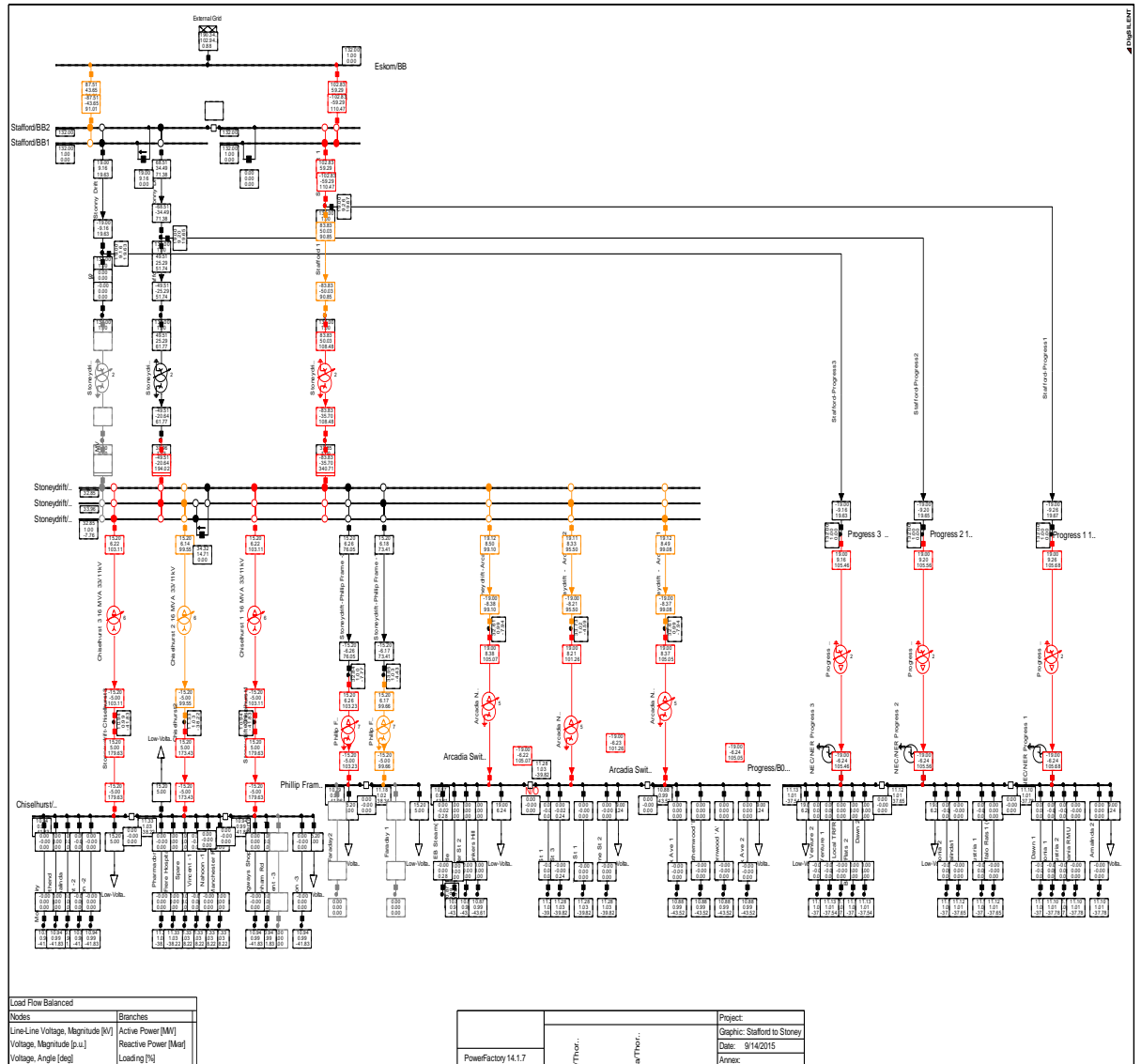

**Figure 4.4:** Existing network simulation results

The load flow simulation is depicted in Figure 4.4, the quantities represented are the results. The network was simulated at 100% loading. The result is used to compare the accuracy of loading between existing and alternative (1) models. Figures E.1, E.2 and E.3 in appendix E presents the expanded version of these results. The result boxes indicates three parameters presentation namely real power (P) in megawatt (MW), reactive power (Q) in megavolt ampere reactive (MVAR) and % loading of the component. Three colour coding indicated in the result boxes are “black, orange or yellow and red”, the black colour indicates normal loading at 80%, the orange or yellow colour present load warning at  $\geq 81\%$  and the red colour indicates loading at  $\geq 100\%$  in a particular set of equipment or line. Figure 3.2 depicts single line diagram of the existing network model.

#### 4.4 Alternative (1) network model

The alternative (1) focus on Stoney Drift substation where 2 x 90 MVA, YNyn0, 132/33 kV transformers, 33 kV yard with 3 x 33/11 kV, 16 MVA, YNd1 transformers and 16 outdoor circuit breakers exist in the same yard (Figure 3.4). There are 6 x 33 kV outgoing feeders, 3 x feeders were supplying Arcadia substation which is now supplied from another 132 kV substation called Queens Park. The remaining 3 x 33 kV feeders supply Philip Frame 33/11 kV, 20 MVA YNd1 transformers in close proximity to the 33 kV yard. This dissertation proposes two alternative models namely alternative (1) and alternative (2) to select appropriate alternative for making an informed decision to salvage the lower reliability performance. There are vital reasons for alternatives to be considered:

- The yard arrangement is complicated for load transfer;
- Arcadia substation is no longer supplied from Stoney Drift substation;
- BCMM's network distribution system supply 11 kV medium voltage (MV) throughout its entire distribution spheres;
- The existing Stoney Drift 33 kV switch yard consist of 16 circuit breakers (refer to Figure 3.4);
- The circuit breakers in the 33 kV yard are older than 35 years in service;
- The 2 x 90 MVA, YNyn0, 132/33 kV transformers are badly leaking oil; and
- There are no circuit breakers for incoming feeders only isolator links and surge arrestors.

The alternative (1) seeks to decommission (eradicate) Stoney Drift 33 kV yard arrangement as shown in Figure 3.4 and replace with 3 x 40 MVA, YNd1, 132/11 kV transformers as shown in Figure 4.6. The alternative (1) network project further consider refurbishing the lines between Stafford and Stoney Drift for the installation of 132 kV circuit breakers for outgoing and incoming feeders respectively. The project also includes replacement of pilot protection wires with optic fibre communication technology.

**IMPROVING BUFFALO CITY'S SUB-TRANSMISSION RELIABILITY  
LOAD FLOW STUDY ON BC'S NETWORK**

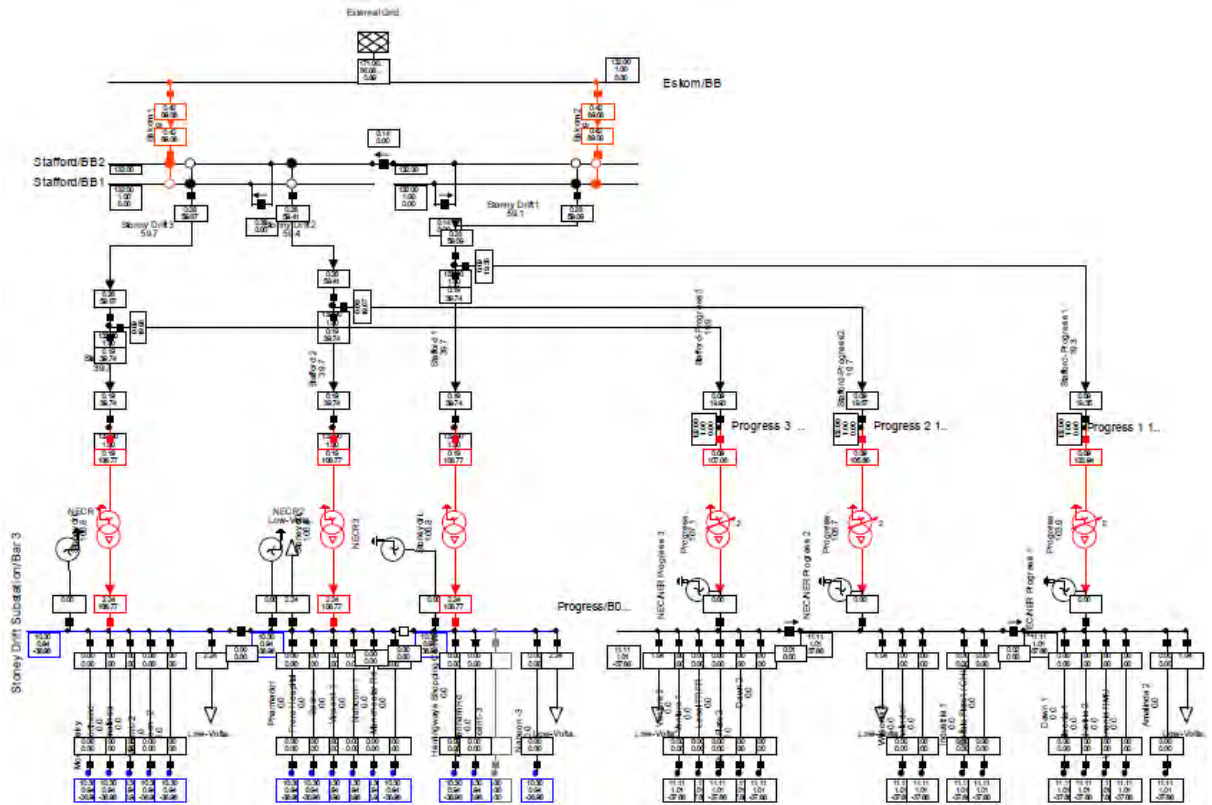

**Figure 4.5:** Alternative (1) network simulation results

Figures E.4, E.5 and E.6 expanded Figure 4.5 in appendix E for clear identification of the figures in the result boxes.

**Table 4.6:** Colour legend

NO	COLOUR	PERCENTAGE LOADING
1	Black	Normal loading at 80%
2	Yellow or Orange	Loading at $\geq 81\%$
3	Blue	Loading at 95%
4	Red	Loading at $\geq 100\%$

IMPROVING BUFFALO CITY'S SUB-TRANSMISSION RELIABILITY  
LOAD FLOW STUDY ON BC'S NETWORK

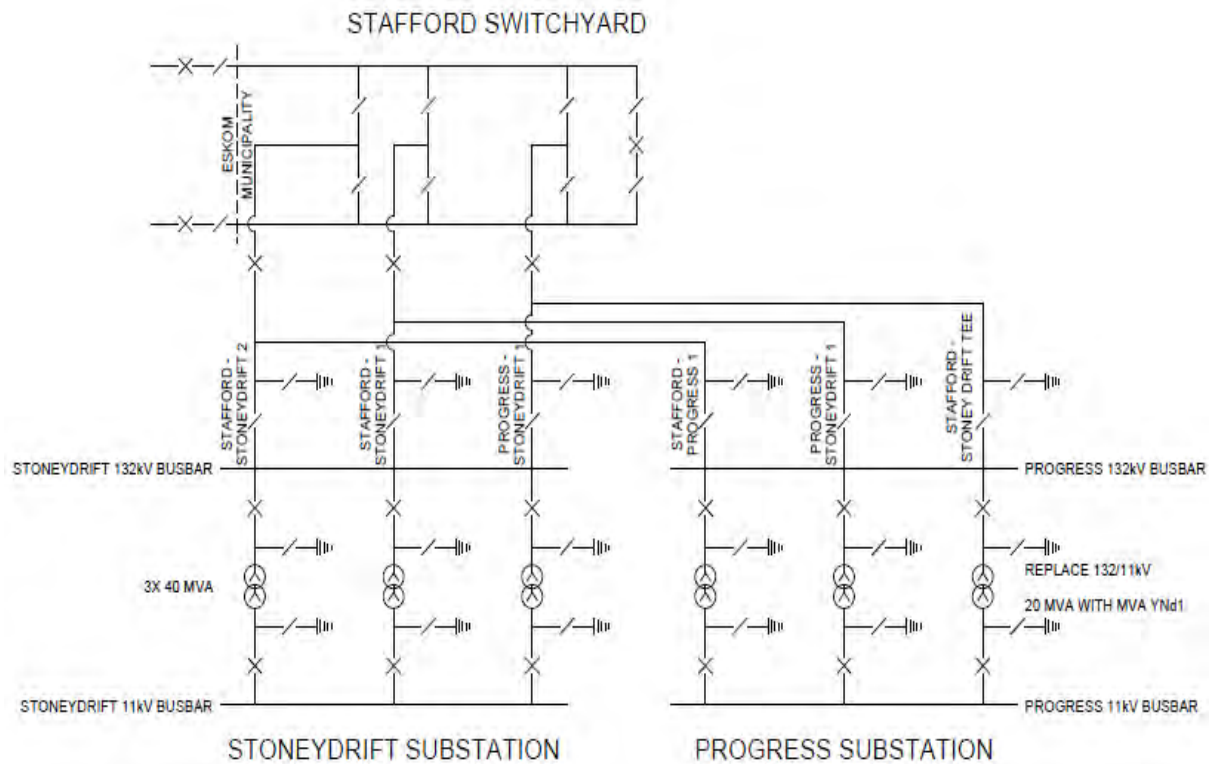

**Figure 4.6:** Single line diagram of alternative (1) network model

#### 4.5 Alternative (2) network model

In this section, BCM's sub-transmission network will be modelled as alternative (2) with standard range of equipment (132/11 kV, 40 MVA, YNd1) in both Stoney Drift and Progress substations. The plan aims to account for the alternative replacement of the existing infrastructure where the condition of equipment requires such on the sub-transmission for reliability improvement. The study assessed the condition of the entire sub-transmission substations and of the key overhead lines to make decision. The assessment was limited to a visual inspection of HV lines and substation equipment. The primary purpose was to determine what electrical infrastructure should be replaced, uprating or upgraded as part of this research study. The condition so determined was kept in mind when considering future development plans. The assessment was split in the following manner: HV power transformers (in substations); and HV overhead lines between Stafford and Stoney Drift.

- **Power transformers**

IMPROVING BUFFALO CITY'S SUB-TRANSMISSION RELIABILITY  
LOAD FLOW STUDY ON BC'S NETWORK

Table 3.1 depicts power transformers on the sub-transmission network system. The recommendation to replace power transformers has been based primarily on the age of the units and their expected design life.

**Table 4.7:** Transformers older than 35 years

Transformers	Stoney Drift/Chiselhurst	Progress
90 MVA, YNyn0, 132/33 kV	2	
20 MVA, YNd1, 132/11 kV		3
16 MVA, YNd1, 33/11	3	
<b>Total</b>	<b>5</b>	<b>3</b>

The existing design in Stoney Drift switchyard is complicated. There are 2 x 90 MVA, YNyn0, 132/33 kV and 3 x 16 MVA, YNd1, 33/11 kV transformers in the same switchyard. BCMM distributes 11 kV on their distribution hubs of the network therefore, it is imperative to replace the 2 x 90 MVA, YNyn0, 132/33 kV transformers at Stoney Drift substation and replace with 3 x 40 MVA, YNd1, 132/11 kV transformer units. With that, the 3 x 33/11 kV, 16 MVA, YNd1 transformers can also be removed. Transformers nearing the end of their life span will be of particular interest to BCMM. Transformer loading over particular period affects transformer life span. Table 4.7 depicts transformer age based on the installation date. A single line diagram of Stoney Drift alternative (2) upgrade is shown as Figure 4.7 below.

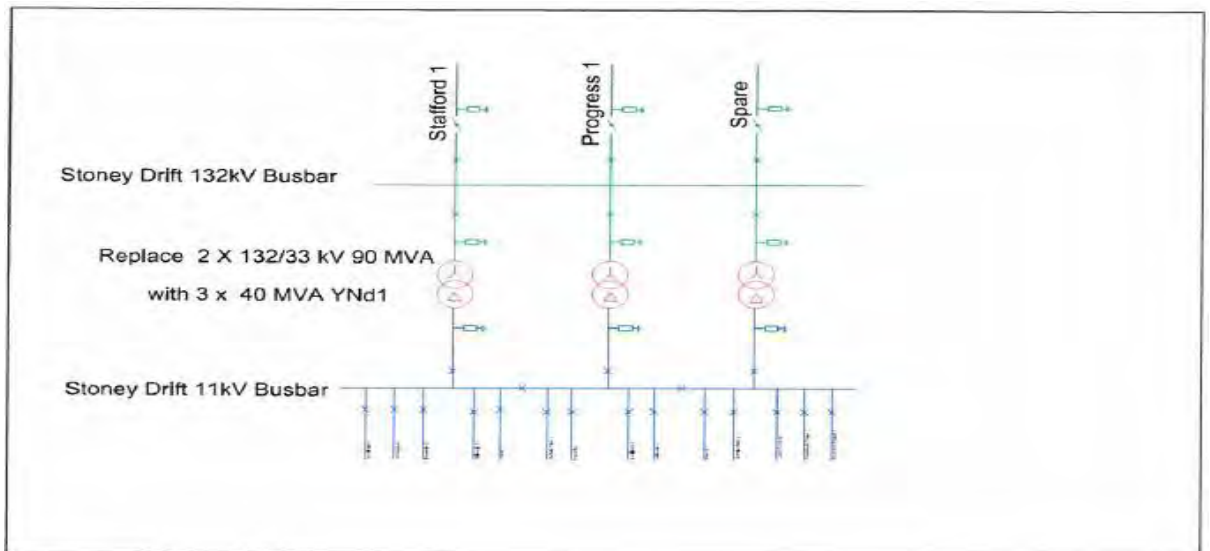

**Figure 4.7:** Alternative (2) Stoney Drift substation single line diagram.

IMPROVING BUFFALO CITY'S SUB-TRANSMISSION RELIABILITY  
LOAD FLOW STUDY ON BC'S NETWORK

Progress substation is currently equipped with 3 x 20 MVA, YNd1, 132/11 kV transformers. The alternative (2) will upgrade the substation with 3 x 40 MVA, 132/11 kV, YNd1 transformers. It is imperative that all the transformers installed be of the same vector group so as to allow back-feeding when required. The existing transformer plinth can be extended should this be required to accommodate the 40 MVA transformers. A single line diagram for the alternative (2) Progress substation is shown as Figure 4.8 below.

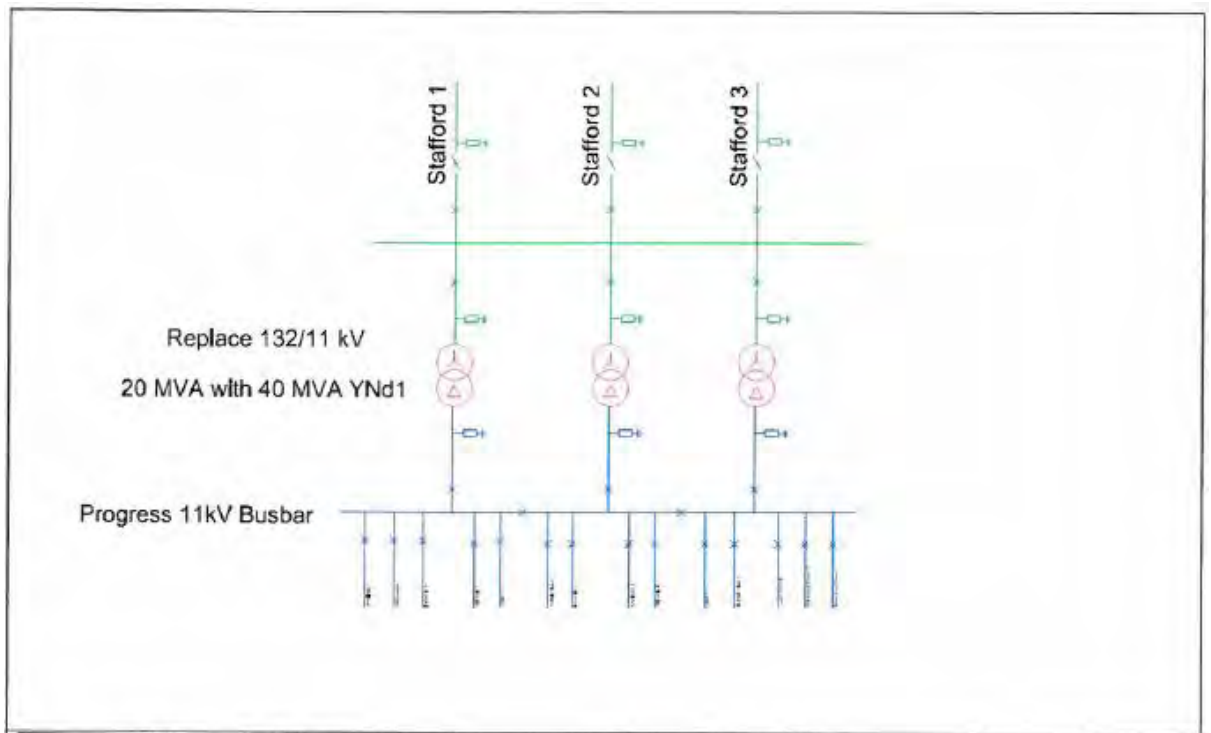

**Figure 4.8:** Alternative (2) Progress substation upgrade single line diagram

Given the high cost of HV power transformers and associated lead time to motivate and secure the necessary replacement budgets, and the time to procure and install new transformers, it would be advisable for the BCMM to continue oil sampling, purification and analysis on a regular basis in order to adjust the timing of replacements recommended in this dissertation.

● **HV overhead lines**

The existing outgoing feeders from Stafford switchyard to Stoney Drift do not have HV circuit breakers. The HV incoming lines at Stoney Drift substation also do not have HV circuit breakers, only line isolators, CT's and surge arresters are provided.



IMPROVING BUFFALO CITY'S SUB-TRANSMISSION RELIABILITY  
LOAD FLOW STUDY ON BC'S NETWORK

yard and 33/11 kV, 3 x 16 MVA, YNd1 transformers at Stoney Drift substation, and 3 x 20 MVA, 132/11 kV, YNd1 transformers at Progress substation and system frequency is 50 Hz.

The existing network model unfortunately offers many disadvantages such as:

- Outgoing and incoming feeders from Stafford switchyard to Stoney Drift do not have HV circuit breakers;
- All HV transformers are older than 35 years with reference to Table 4.7;
- Regular unplanned power interruption is eminent;
- Planned preventative maintenance not available;
- Operational difficulties in load transfer;
- Aging infrastructure equipment is eminent;
- The network configuration does not allow planned preventative maintenance to be carried out; and
- Reliability performance is low.

For the purposes of comparison, two (existing and alternative (1)) scenarios are created where all transmission lines are simulated using the same model and with 100% loading with the same software. The comparison of results is defined as relatively how well balanced network loading scenario emanate. The results of both network models are clearly (visual enhancement) presented as percentages as well as colour coding in Figure 4.5 as well as Figures E.1, E.2, E.3, E.4, E.5 and E.6 in appendix E. Colour legend is set in order to help identify changes. The colour legend is shown as Table 4.6.

The results show the changes are related in magnitude and percentage loading of the bus voltages. The use of alternative (1) network model shows voltage flow can be known, and the lines should not be overloaded.

IMPROVING BUFFALO CITY'S SUB-TRANSMISSION RELIABILITY  
LOAD FLOW STUDY ON BC'S NETWORK

The results show the significant changes in loading at the bus voltages with the alternative (1) model. Even though both network simulation were carried out at 100% loading, there is significant changes in loading from Red to Black between Stafford and tee-off, as well as from Red to Orange between Eskom's Buffalo and Stafford. The use of alternative (1) network model offers several advantages such as:

- It is easy to be implemented and requires low civil works;
- It offers safe load transfers (switching);
- It gives opportunity for service personnel to carry out planned preventative maintenance to upkeep aging equipment;
- It makes circuit breakers available on outgoing feeders from Stafford and incoming feeders to Stoney Drift;
- Pilot protection scheme will be restored;
- It will decrease unexpected downtime;
- Pilot protection scheme functionality restored;
- Protective relays will be responsive to faults;
- New equipment will strengthening the network system;
- Reduce operating and maintenance costs;
- Get more capacity out of existing assets; and
- System transmission loss minimizes.

However, this simple and easy model has few disadvantages:

- Budget must be raised for new transformers;
- New 132 kV circuit breakers need to be purchased; and
- Construction of new transformer plinths.

#### **4.7 Cost effectiveness of alternatives (1) and (2)**

The better approach compares the cost of alternative (1) network with the corresponding alternative (2) network models. The criterion in systems decision making has been to use least-cost resources and to meet the required level of reliability performance required. The objective is to minimize investment, operating and outage costs over the period considered. The point of minimization

IMPROVING BUFFALO CITY'S SUB-TRANSMISSION RELIABILITY  
LOAD FLOW STUDY ON BC'S NETWORK

cost marks the optimal level of reliability to be used as a benchmark in the system. The alternative network model focus on decommissioning 2 x 90 MVA, YNyn0, 132/33 kV and 3 x 16 MVA, 33/11 kV, YNd1 transformers in Stoney Drift substation and commission 3 x 40 MVA, 132/11 kV, YNd1 transformers. The cost estimated for the completion of this project is R8.48m. Alternative (2) network model considers decommissioning 3 x 20 MVA, 132/11 kV, YNd1 transformers in Progress substation and replace it with 3 x 40 MVA, 132/11 kV, YNd1 transformers as well as decommissioning equipment in Stoney Drift substation as mentioned above and replace with 3 x 40 MVA, 132/11 kV, YNd1 transformers.

**Table 4.8:** Provisional cost estimates

No.	Substation Name	Cost
1	Stoney Drift substation	R8.48m
2	Progress substation	R8.48m

The estimated cost for completion of this project is twice as the alternative (1) network model project at R16.96m. With reference to subsection 2.6.3, this sort of cost-effectiveness criterion implies a priority selection of a reliability level, usually based on experience and judgment. However, an increase in reliability may be advisable even if it results in a slight increase in cost, and a slight reduction in high reliability may be acceptable if it results in significant savings. Accordingly, to reach an economically efficient outcome, the benefits gained by reliability improvements should be assessed against the costs of additional capacity. This clearly implies that, the alternative (2) network model is expensive for interim implementation. Perhaps it may be considered as a long-term plan for future implementation in accordance with the city population growth. Therefore, the alternative (1) network model is selected due to its cost-effectiveness which can also be considered as a short-term solution to the BCMM's reliability problems. The alternative (1) network model will reduce loading pressure on sub-transmission line and equipment to improve reliability. The alternative (1) model provides better network loading to curb overloading problems.

## **CHAPTER 5: FAULT LEVEL STUDY ON BC'S NETWORK**

The fault level at any given point of electric power supply network is the maximum current that would flow in case of a short circuit fault at that point. In normal power systems operating conditions, current will flow through all elements of the electrical power system within predetermine values which are appropriate to these elements' ratings. Power system can be analysed by calculating the system voltages and currents under normal and abnormal scenarios [80]. The purpose of fault level calculations are for:

- Selecting short circuit protective devices of adequate short circuit breaking capacity;
- Selecting circuit breakers and switches of adequate short circuit making capacity;
- Selecting busbars, busbar supports, cables and switchgear designed to withstand thermal and mechanical stresses because of short circuit; and
- To do current based discrimination between circuit breakers.

### **5.1 Introduction**

Faults usually occur in a power system due to either insulation failure (insulation deterioration) results in a flashover, physical damage by human error (during construction or vandalism etc.). These faults, may either be three phase in nature involving all three phases in a symmetrical manner, or may be asymmetrical where usually only one or two phases may be involved. These faults may also be caused by either short-circuits to earth or between live conductors, or may be caused by broken conductors in one or more phases results in open circuit fault. Sometimes simultaneous faults may occur involving both short-circuit and open conductor faults (also known as open-circuit faults). These are also known as shunt and series faults respectively.

### **5.2 Types of faults**

The analysis of faults leads to appropriate protection settings which can be computed in order to select suitable fuse and circuit breaker size, and type of relay [80]. The severity of the fault depends on the short-circuit location, the path taken by fault current, system impedance and its voltage level. In order to maintain the

continuation of power supply to all customers which is the core purpose of the power system's existence, all faulted parts must be isolated from the system temporarily by the protection schemes. When a fault exists within the relay protection zone at any transmission line, a signal will be sent to trip or open the circuit breaker isolating the faulted line. To complete this task successfully, fault analysis has to be conducted in every location assuming several fault conditions. The goal is to determine the optimum protection scheme by determining the fault currents & voltages. In reality, power system can consist of thousands of buses which complicate the task of calculating these parameters without the use of computer software such as DIgSILENT Power Factory.

There are two types of faults which can occur on any transmission line; balanced and unbalanced faults or symmetrical and unsymmetrical faults. Unbalanced faults can be classified into single line-to-ground fault, double line fault and double line-to-ground fault. Balanced fault is also classified as three phase fault.

### **5.2.1 Three phase fault**

*“By definition a three-phase fault is a symmetrical fault. Even though it is the least frequent fault occur in power system network, it is the most dangerous fault. Some of the characteristics of a three-phase fault are a very large fault current and usually a voltage level equals to zero at the site where the fault takes place. A general representation of a balanced three-phase fault is shown in Figure 5.1 where  $F$  is the fault point with impedances  $Z_f$  and  $Z_g$ . In reality, this type of fault does not often exists which can be seen from its share of 5% of all transmission line faults” [81].*

Figures 5.1, 5.2, 5.3 and 5.4 shown below indicates the types of fault to be considered in the power system planning stage which could cause disturbances on the power systems network including three phase fault, single line-to-ground fault, line-to-line fault, and double line-to-ground fault respectively.

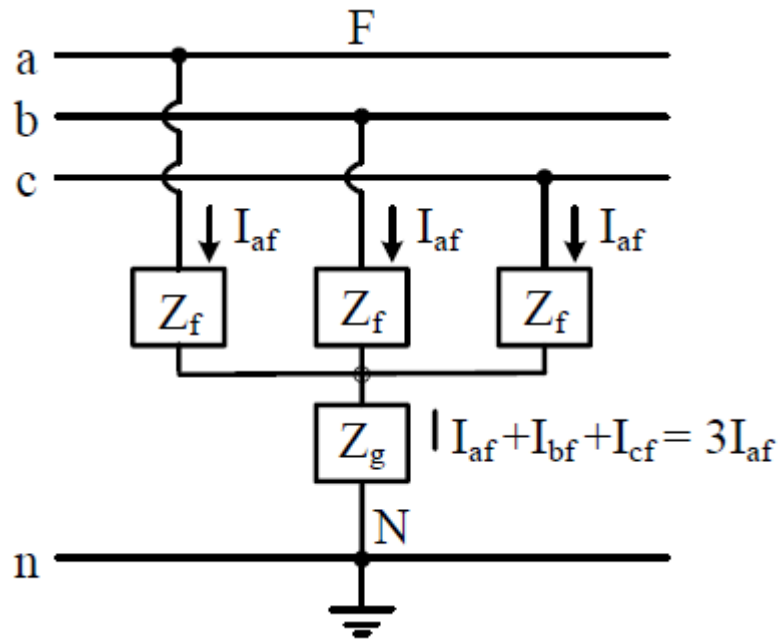

**Figure 5.1:** General representation of a balanced three-phase fault (adapted from [81])

### 5.2.2 Single line-to-ground fault

*“The single line-to-ground fault is usually referred as “short circuit” fault and occurs when one conductor falls to ground or makes contact with the neutral wire. The general representation of a single line-to-ground fault is shown in Figure 5.2 where F is the fault point with impedances  $Z_f$ . Phase **a** is usually assumed to be the faulted phase, this is for simplicity in the fault analysis calculations”* [82].

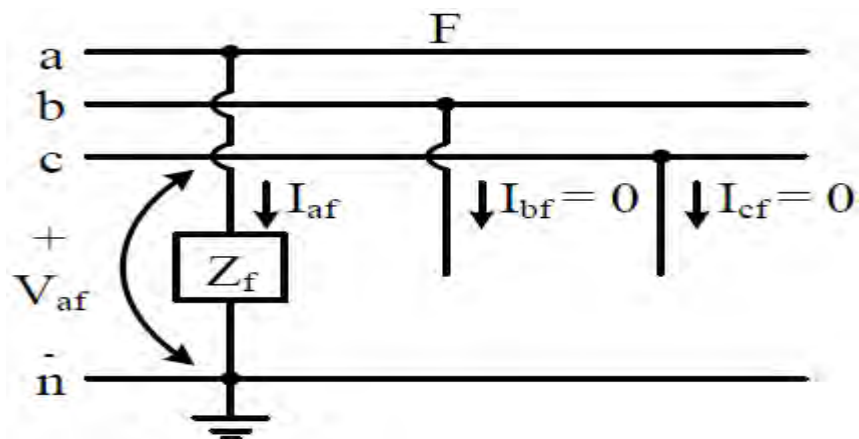
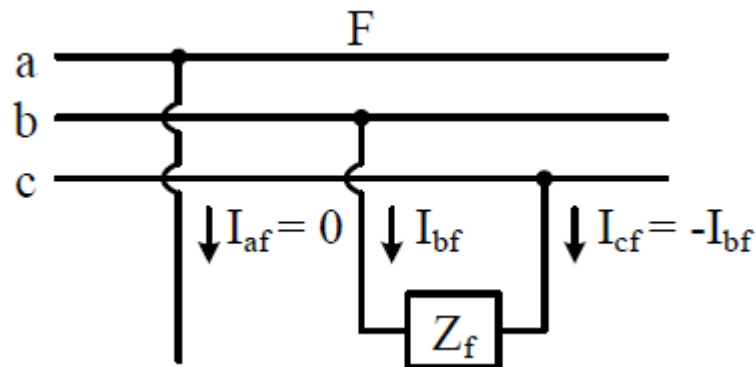

**Figure 5.2:** General representation of a single line-to-ground fault (adapted from [82]).

“Line-to-ground fault: this type of fault exists when one phase of any transmission lines establishes a connection with the ground either by ice, wind, falling tree or any other incident and it count for 70% of all transmission line faults are classified under this category” [82].

### 5.2.3 Line-to-line fault

“A line-to-line fault may take place either on an overhead and/or underground transmission system. It occurs when two conductors are short-circuited. One of the characteristic of this type of fault is that its fault impedance magnitude could vary over a wide range making very hard to predict its upper and lower limits. It is when the fault impedance is zero that the highest asymmetry at the line-to-line fault. The general representation of a line-to-line fault is shown in Figure 5.3 where  $F$  is the fault point with impedances  $Z_f$ . Phase  $b$  and  $c$  are usually assumed to be the faulted phases; this is for simplicity in the fault analysis calculations” [81].



**Figure 5.3:.**General representation of a line-to-line fault (adapted from [81])

“Line-to-line fault: It happened as a result of high winds, one phase could touch another phase and line-to-line fault takes place and it count for 15% of all transmission lines faults are considered line-to-line faults” [81].

### 5.2.4 Double line-to-ground fault

“A double line-to-ground fault represents a serious event that causes a significant asymmetry in a three-phase symmetrical system and it may spread into a three-phase fault when not clear in appropriate time. The major problem when analysing this type of fault is the assumption of the fault impedance  $Z_f$ , and the value of the impedance towards the ground  $Z_g$ ” [81]. “The general representation of a double

line-to-ground fault is shown in Figure 5.4 where  $F$  is the fault point with impedances  $Z_f$  and the impedance from line to ground  $Z_g$ . Phase  $b$  and  $c$  are assumed to be the faulted phases, this is for simplicity in the fault analysis calculation". [82].

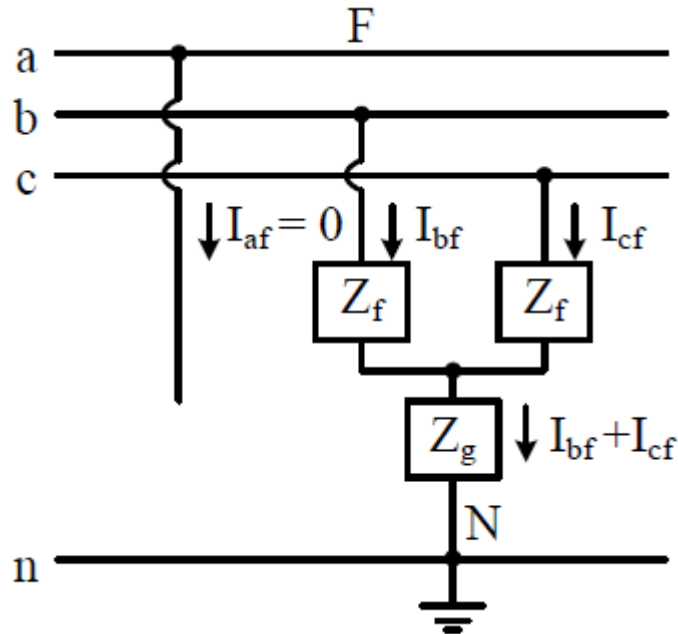

**Figure 5.4:** General representation of a double line-to-ground fault (adapted from [82])

“Double line-to-ground: two phases will be involved instead of one at the line-to-ground faults scenarios and it also count for 10% of all transmission lines faults are under this type of fault” [82].

### 5.3 Comparison of existing and Alternative (1) fault level simulation

Since symmetrical components method includes many matrix operations and computer can be utilized to perform fault analysis in well-organized, effective, faster and logical means. In addition, the data can be used to accomplish this task where existing and alternative (1) network models are simulated. DIgSILENT Power Factory was selected as the simulation tool in this dissertation due to several reasons. Our background of DIgSILENT Power Factory (used for load flow analysis) was the main reason behind this choice. In addition, any data can be edited and modified easily to handle any future cases using the command edit window.

IMPROVING BUFFALO CITY'S SUB-TRANSMISSION RELIABILITY  
FAULT LEVEL STUDY ON BC'S NETWORK

Also, DIgSILENT Power Factory contains many built-in functions to resolve different electrical problems. DIgSILENT Power Factory software program has been applied through every selected substation to determine 3 phase and single short circuit current levels. Fault current is a function of the total system impedance and the available voltage.

#### **5.4 Existing network fault level simulation**

The simulation results of the existing network model indicates existence of (21 kA, and 14.4 kA) 3 phase and (8.16 kA and 18.3 kA) 1 phase fault levels for Progress and Stoney Drift respectively. The existing network experiences regular unplanned power interruptions including blackouts in 2006 and 2008. Aging infrastructure equipment increases probability of fault to occur on the network. No relay communication due to unavailability of the pilot wires. Fault on the existing network is unpredictable. Fault occurred at downstream of the network escalates to tripping the infeed circuit breakers (no proper fault segregation). Due to aging equipment, reactive maintenance, non-responsiveness of protective devices, reliability level is low. BC's existing network manual fault level calculations is presented in appendix F.

#### **5.5 Alternative (1) network fault level simulation**

Alternative (1) network simulation carried out indicates (7.4 kA and 6.3 kA) 3 phase and (11.6 kA and 10.2 kA) 1 phase fault levels at Progress and Stoney Drift substations respectively. With reference to subsection 4.4, the alternative (1) network model will be strengthened with replacement of new equipment which provides adequate information to calculate relevant impedances. Impedance play an important role in determining network fault levels. With reference to subsection 4.6 paragraph 4 elaborate the advantages of alternative (1) network model.

#### **5.6 Fault level comparative analysis**

Faults in the AC sub-transmission are divided into two categories namely 3 phase and single phase faults. The first is the fault when feeding through the transmission line and depending on the fault type and duration can cause poor reliability

IMPROVING BUFFALO CITY'S SUB-TRANSMISSION RELIABILITY  
FAULT LEVEL STUDY ON BC'S NETWORK

performance of the network. Three phase faults in the transmission lines feeding the substations have the worst effect resulting on power transformers to cause unplanned interruption. However, considering single phase or two phase faults, lower power can be fed to substations and the rest of the power demand can be gained from adjacent trunk feeders or substations, therefore, not all customers will experience power interruption. Table 5.1 shows comparative 3 phase and single phase fault levels in BCMM's sub-transmission's respective busbars. The results of the existing and alternative (1) network model simulation with DIgSILENT Power Factory is depicts in Table 5.1. Comparatively, the results are totally different at Progress and Stoney Drift bus with exception of the fault level in Stafford switchyard. It is important to compare between existing and alternative (1) model in order to make accurate fault level analysis. Considering the severity of faults, this dissertation compares 3 phase and a single phase fault levels, A lower fault level on the network will have detrimental effect on the protection system co-ordination. A medium fault level results is preferable, the protection systems functions precisely to achieve system reliability. A higher fault level in an interconnected power system network will lead to selection of higher current rating equipment and that have an impact on the older network equipment negatively.

**Table 5.1:** Comparative fault level analysis

Fault level at Bus	Existing network model Simulation result in kA		Proposed network model simulation result in KA	
	3 Phase	1 Phase	3 Phase	1 Phase
<b>Stafford switchyard</b>	11.2	13.3	11.2	13.3
<b>Progress substation</b>	21	8.16	7.4	11.6
<b>Stoney Drift substation</b>	14.4	18.3	6.3	10.2

IMPROVING BUFFALO CITY'S SUB-TRANSMISSION RELIABILITY  
FAULT LEVEL STUDY ON BC'S NETWORK

Fault level comparative analysis shows alternative (1) network simulation has a reasonably medium fault level at the respective busbars. Interestingly, it is acknowledged that both network have the same fault levels at the supply source. This is due to the fact that, the source impedance is the same in both network models. The network system impedance has significant effect in determining fault level at the bus. Network configuration also have important role to play with regard to determining a fault level on a network. Therefore, it is imperative to consider using alternative (1) network model for implementation in reliability improvement.

## CHAPTER 6: DISCUSSIONS

The discussions of reliability improvement on BCCM's electricity network is indispensable. In this section, the eminent problems and conditions where improvement is valid is discussed. The improvement is based on aging infrastructure, protection scheme, maintenance practice, load flow and fault level of the BCMM's sub-transmission network.

### 6.1 Aging infrastructure equipment

Infrastructure aging of power system is of great concern in the BCMM'S electricity network. For example, Table 4.7 elaborate on the aging transformers which are older than 35 years. These 3 x 20 MVA, 132/11 kV, YNd1 and 2 x 90 MVA, 132/33 kV, YNyn0 transformers are situated in the main distribution hubs of Progress and Stoney Drift substations respectively. Buffalo City's existing sub-transmission network, dating back to 1972. The relative equipment are now 44 years in service, including overhead line from Stafford switchyard to Progress/Stoney Drift, transformers and circuit breakers. No repairing and possibly lack of accurate timing of replacement of old equipment, overloading and regular power outages of the system can be mentioned as reasons of aging the sub-transmission system [6].

- Overhead lines: Major factor that causes conductor aging is annealing which due to high line temperature. Annealing is the process where the tensile strength of a copper or aluminium conductor is reduced at the sustained high temperatures.

Although the conductor strength is reduced gradually, the reduction due to conductor aging, which is accumulated over time is increasing the probability of blackouts. Furthermore, the current-carrying capacity of an overhead line conductor is often determined by the loss of its tensile strength as a result of cumulative annealing during its planned lifetime or aging. Aging overhead conductor experience hotspots, sags and weak terminations.

- Transformer: The aging transformers can be identified with overheating, reduced oil insulation property, regular temperature alarm going off, oil leaks at the bushing, load losses etc. It further requires top oil temperature rise over ambient at rated load, bottom oil temperature rise over ambient at rated load. Aging

transformer with aging oil causes deterioration, such as ingress of moisture, ingress of air and oversaturation of gas.

- Circuit breakers: Aging circuit breakers experienced with main problems namely mechanical faults with drive mechanism, contact erosion and leakage. Since BCMM's Progress and Stoney Drift substations are outdoors, heating can be exacerbated for equipment by solar radiation. It can be identified with compound leakage chambers, gasket joints for leakage and corrosion.

## **6.2 Reactive maintenance**

When a piece of equipment is aging and can no longer be used in normal operating state and must be retired, maintenance can prolong its physical life time. However, practicing reactive maintenance may not prolong the physical life time rather the network will be experiencing unpredictability, equipment not maximised and indirect costs.

- Unpredictability: one of the main disadvantages of reactive maintenance is unpredictability of when faults may occur. This lack of knowing and preparation may well result in either labour or materials being unavailable immediately and therefore delay the time taken for a repair and increasing equipment downtime.
- Equipment not maximised: Reactive maintenance doesn't protect or look after equipment and therefore reduces the life span of the equipment. Rather than preserve the equipment and ensure its functionality in optimum condition, reactive maintenance approach does the bare minimum to keep equipment operational. The negative effect of this is that the equipment won't fulfil its potential or return on investment.
- Indirect costs: Further indirect costs are found with reactive maintenance with equipment downtime or unreliable equipment causing negative effects on reputations, safety and the ability to run the network effectively and productively. Furthermore, hiring contractors for an assistance in time of emergencies is a costly exercise.

## **6.3 Non-responsiveness of protective devices**

The case study 1, elaborates how protection system fail to operate quickly enough and selectively in a presence of a fault, and how the fault escalated to trip infeed

circuit breakers situated in Eskom's Buffalo substation. With the case study 2, though, the cause of blackout is unclear however, many options are elaborated to substantiate the possible cause of the accident. These are some possible causes, circuit breaker's failure 'to clear the fault' could be; either the circuit breaker was not tripped by the protection relay, or the circuit breaker was damaged and could not operate, or the circuit breaker operated but did not clear the fault because there was flashover across the breaker or on other parts of the substation upstream of the circuit breaker. Nonexistence of pilot wires was identified between Stafford and Progress/Stoney Drift substations. Furthermore, no circuit breakers installed at the outgoing Stafford feeders and receiving end feeders at Stoney Drift substation for relay co-ordination.

#### **6.4 Load flow analysis**

Load flow: The conditions of validity of load flow analysis are given in Figure 4.4. Figure 4.4 clearly shows the validity of component being overloaded including transmission lines and busbars. The load flow result shows existing network is overloaded from Eskom's source of supply to Stafford switchyard, another line from Stafford to Stoney Drift is overloaded and all three feeders to Progress substations are also overloaded

#### **6.5 Fault level analysis**

Fault levels of power system cannot be over emphasized. Fault contribute immensely to power systems interruption. Both dependability and security can be negatively affected if fault levels on the network are incorrect (either high or low fault level). Correct protective relay settings, co-ordinations and operations will depend upon correct and precise determination of fault levels at the relevant busbars on the network. For instance, a bolted phase to ground fault will necessarily have a lower fault current than a bolted phase-phase fault because the phase-to-ground voltage is inherently higher. However, a high-impedance phase-to-phase fault could certainly have a lower current than a bolted phase-to-ground fault. Line-to-ground and 3 phase faults: For a line to ground fault, the fault current is the highest as compared to other fault conditions given the same value of fault impedance. Often the thinking is that a 3 phase fault is the most severe so

IMPROVING BUFFALO CITY'S SUB-TRANSMISSION RELIABILITY  
DISCUSSIONS

it will have the highest fault current which of course is not the case. Fault current is the highest in a line-to-ground fault but 3 phase faults are more severe because of other repercussions that they have on the generator such as electrical power output becoming zero. Another typically example happens close to a transformer where the zero sequence impedance is low or zero. However as you move further from the transformer, the zero sequence impedance grows higher than the positive sequence as you move away from the transformer. Regular power interruptions eminent on BCMM's sub-transmission network is discussed.

## CHAPTER 7: CONCLUSIONS AND RECOMMENDATIONS

### 7.1 Conclusions

Dissertation for improving Buffalo City's sub-transmission reliability under University of Cape Town for academic requirement has been presented. The approach to completing the dissertation is outline as follows:

- Data collection and verification: Review of all technical data provided for this study including the previous outage data, network information and drawings. This task included various site meetings, staff interviews and site inspections.
- BCMM's sub-transmission overview: The supply intake, Eskom's Buffalo substation and Buffalo City's Stafford switchyard arrangement showing 2 x 132 kV circuits to Stafford with 2 x 132 kV circuit breakers has been presented. The supply intake re-configuration to make 3 x outgoing 132 kV lines (circuits), in order to supply Stoney Drift and Progress substations have also been presented. The physical construction of the sub-transmission systems made no provision to allow circuit breakers to be installed in Stafford for the outgoing feeders as well as no provision made for 132 kV circuit breakers to be installed at the receiving end Stoney Drift substation has been presented. BCMM's sub-transmission main equipment, problem categorization and factors affecting the lower reliability performance have been presented.
- Blackouts: The case study of BCMM's sub-transmission network blackouts, impacts from the regular outage and restoration process have been presented, and blackout mitigation as well as prevention are studied. The nonexistence of pilot wires between Stafford switchyard and Stoney Drift substation and non-responsiveness of protective device have been reviewed.
- Exploration of equipment reliability performance: Protection system security and dependability, aging equipment and maintenance have been investigated.
- Load flow study: Perform a load flow study of the existing and alternative (1) models utilising DIgSILENT Power Factory to assess the capacity of the network to meet the required load balancing and fault level calculation. A network models was prepared and used to study the network under various loading scenarios. The comparison of fault level scenarios made provision to allow precise overcurrent and earth fault relay settings.

IMPROVING BUFFALO CITY'S SUB-TRANSMISSION RELIABILITY  
CONCLUSIONS AND RECOMMENDATIONS

- Discussions: Discussions on a desk study of possible solutions, and selection of best solution that uses decision making approach have been made.
- Provisional cost estimated: Based on the interim and long-term scenarios, plans and schedules, provisional estimates were prepared using BCMM's database prices and costs estimating tools together with the occasional budget price from suppliers for high cost items.

The existing network supply from Eskom is deteriorating and has lower reliability performance level. The insufficient level of adequacy and security provides vulnerability for the network to experiencing regular power interruptions. Stoney Drift and Progress substations are currently loaded to their capacity limits. The load balancing emanate from an analysis of the available simulation result of the alternative (1) scenario provides interim solutions to BCMM's reliability problems.

## **7.2 Recommendations**

This section aims to provide a concise summary of a key recommendations made in this dissertation in a specific order. The order is based on factors influencing lower level reliability performances are recommended.

### **7.2.1 Aging infrastructure equipment**

If it is to manage aging infrastructure equipment and its effect on reliability performance, well applicable generalization strategy that can be applied to aging utility infrastructure is as follows:

- (a) Overhead lines: Visual inspections must be carried out at reasonable pace of intervals. A visual inspection will identify loose components, improper grounding, missing notices, problem trees and problem structures to be maintained;
- Conductor corrosion can be detected by an eddy-current technique to detect the galvanic corrosion process in steel reinforced aluminium conductor [82];
- Inspection, maintenance and service priorities must be different for older equipment;
- Information on age, condition, and service and maintenance history must be the key to salvage older equipment; and
- Condition monitoring technique implementation is highly recommended.

(b) Transformers: Transformers must be visually inspected at regular intervals for rust and leakages. Condition of the transformer oil must be tested for dielectric breakdown, water content, power factor, flashpoint, corrosive sulfur, viscosity, dissolved gas analysis etc. and carried out preventative maintenance;

- Electrical testing must be carried out for insulation resistance, loss angle, partial discharge and low voltage impulse;
- Oil filled bushing and tap changers must be tested for gas in the oil; and
- All ancillary transformer equipment and instrumentation must be visually inspected and tested regularly for planned maintenance.

(c) Circuit breakers: Visual inspection and maintenance must be carried out on outdoor switchgear/circuit breakers to identify corrosion, cleaning, painting and regular servicing; and

- Prevent rodents and other small animals from nesting in pad-mounted equipment is necessary and carried out preventative maintenance.

### **7.2.2 Planned preventative maintenance**

This dissertation recommend planned preventative maintenance (PPM) strategy to be adapted as one of the techniques to mitigate BCMM's lower reliability problems. Planned preventive maintenance (PPM) is to maintain the infrastructure equipment before failure. Therefore, a balance needs to exist between the frequency and extension of maintenance carried out. Routine inspection with equipment check list and planning must be exercised to planned preventative maintenance. Implementation of PPM will reduce maintenance costs and increase reliability performance level.

### **7.2.3 Protection system on BC's network**

In this dissertation, operating a line without pilot protection scheme was discussed. The possible interim solution to the current scenario is as follows:

- Modify the relay settings/wiring to emulate pilot tripping is recommended. If the line is needed for load flow capability but instability or severe voltage sags for slow clearing of faults is a risk, then some other alternatives to provide fast clearing are possible. Recommended alternatives to be considered are as follows:

IMPROVING BUFFALO CITY'S SUB-TRANSMISSION RELIABILITY  
CONCLUSIONS AND RECOMMENDATIONS

- Extend the Zone 1 reach to at least 100% of the line;
- Shorten the Zone 2 timer to zero or near zero to provide faster clearing for Zone 2 faults; and
- Jumper the PT (permissive trip) input for a permissive overreaching transfer trip (POTT) scheme to enable a pilot trip even though the channel is unavailable or degraded.

Caution should be taken when utilizing these solutions, as all these modifications have vulnerability to lines incorrectly tripping for faults external to the line. In the long-term;

- Install pilot protection scheme to restore Buffalo City's sub-transmission network pilot protection scheme.
- Verify that the control and protection systems operate properly and provide the appropriate alarms, relay communication and co-ordination.
- Testing and maintenance must be carried out at reasonable intervals
- Traveling wave based protection for transmission line, can be used for fast fault detection.

#### **7.2.4 Load flow on BC's network**

The concept of load flow analysis is also true when all reasons of faults are considered for simulation. From the power system point of view, condition of each component or line should be satisfied with the normal voltage loading level for operational excellence and long technical life time.

- Load flow analysis to determine how the electrical network system must be performed after normal and emergency operating conditions. This will yielding provision of information needed to optimize circuit usage, develop practical voltage profiles, minimize kW and kVar losses, develop equipment specification guidelines and identify transformer tap settings.
- Perform LFA to decrease unexpected downtime;
- Carry out load flow analysis to reduce operating and maintenance costs; and
- Carry out LFA to identify capacity out of existing assets.

### **7.2.5 Fault level on BC's network**

Fault level calculation is necessary to ensure that all the components in the power system can safely handle the maximum fault currents if fault do occur.

- Fault level analysis must be carried out by BCMM for additional load on the network if required.
- Fault level must also be used to decide circuit breaker rating in power system.
- It is further recommended that, purchases of new switchgears should be decided on the basis of three phase short circuit current.
- Recommendation is emphasised on the importance of taken into account fault level for the selection of protective devices capable to withstand fault current and break the specified limit as predetermined.

All these recommendations can take time and resources to implement effectively. Thus, with only a limited funds available, it will be important for BCMM to consider the relative cost-benefits in the interim solutions provided in terms of efficiency and reliability improvement activities. Adaptation of the alternative (1) network model of BCMM's sub-transmission provides the best results in network loading, relay responsiveness, upkeep and maintenance strategy for reliability improvement.

**REFERENCES**

- [1] Brown R. E. *Electric Power Distribution Reliability*, Marcel Dekker, New York, 2002.
- [2] Evans J.W. "Influence of Power System Protection on System Blackouts," Merz McLellan, England, 1998, [online] Available: [www.ieeexplore.ieee.org](http://www.ieeexplore.ieee.org).
- [3] MacCalley J. "Operational defence of power system cascading sequences: probability, prediction & mitigation," Power Systems Engineering Research Center (PSerc) Seminars, Oct. 2003.
- [4] Deng S. Meliopoulos S. Mount T. etc "Modeling Market Signals for Transmission Adequacy Issues: Valuation of Transmission Facilities and Load Participation Contracts in Restructured Electric Power Systems", Power Systems Engineering Research Center, Feb 2007, pp 1.
- [5] Glover J. and Sarma M. *Power System Analysis and Design*, 2<sup>nd</sup> Ed, PWS Publishing, Boston 1994.
- [6] Li W., Vaahedi E. and Choudhury P. "Power system equipment aging," IEEE Power Energy Mag., vol. 4, no. 3, pp. 52–58, May–Jun. 2006.
- [7] Kim H., Singh C. "Reliability Modeling and Simulation in Power Systems with Aging Characteristics," IEEE Trans. Power Sys., vol. 25, no. 1, pp. 21-28, Feb. 2010.
- [8] Li W., "Incorporating aging failures in power system reliability evaluation," Power Systems, IEEE Transactions on, vol. 17, no. 3, pp. 918–923, 2002.
- [9] Munasinghe M., Sanghvi A.P., .Reliability of Electricity Supply, Outage Costs and Value of Service: An Overview. *IAEA Special Issue Electricity Reliability Issue Volume 9*, (1988).
- [10] Mohamed A. Wahab A, Hamada M.M., Zietoun A.G, Ismiel G. "Novel modelling for the prediction of aged transformer oil characteristics" Electric Power Systems Research 51 (1999) 61.
- [11] Asgarpoor S. and Singh C., "Methods for Detection of Equipment Aging and Incorporating it in the Reliability Analysis", Proceedings of NSF Symposium on Electric Power Systems Infrastructure, Pullman, WA, October 1994.

IMPROVING BUFFALO CITY'S SUB-TRANSMISSION RELIABILITY  
REFERENCES

- [12] Li W., Waahedi E. and Choudhary P, “Power system equipment aging”, IEE Power and energy magazine, vol. 4, No. 3, pp 52-58, May/June 2006.
- [13] Li Z. and Guo J., \_Wisdom about age, IEEE Power and Energy Magazine, vol. 4, no. 3, pp. 45\_51, May/June 2006.
- [14] Brown R.E. and Willis H.L., \_The economics of aging infrastructure, IEEE Power and Energy Magazine, vol. 4, no. 3, pp. 36\_43, May/June 2006.
- [15] 2007 general rate case: Distribution operations costs, Chapter 4: Substation asset management,\_ Pacific Gas and Electric Company, 2004. [Online]. Available: [https://www.pge.com/regulation/GRC2007-Ph-I/Testimony/PGE/2005-01-Fwd/GRC2007-Ph-I\\_Test\\_PGE\\_20051202-077-Exh004-Ch04.doc](https://www.pge.com/regulation/GRC2007-Ph-I/Testimony/PGE/2005-01-Fwd/GRC2007-Ph-I_Test_PGE_20051202-077-Exh004-Ch04.doc).
- [16] 2006 general rate case: Policy,\_ Southern California Edison, Dec. 2004. [Online]. Available: [http://www3.sce.com/law/CPUCProceedings.nsf/ED4529BC1877F7F888256FB100637F96/\\$File/S01.doc](http://www3.sce.com/law/CPUCProceedings.nsf/ED4529BC1877F7F888256FB100637F96/$File/S01.doc).
- [17] 2006 general rate case rebuttal testimony: Overview,\_ Southern California Edison, May 2005.
- [18] Billinton R. and Allan R.N., “Reliability of Power Systems”, London: Pitman Advanced Publishing Program, (1982)
- [19] Anderson P.M., Power System Protection, McGraw-Hill /IEEE Press, New York, NY, 1999.
- [20] Billinton R. and Allan R. *Reliability Evaluation of Power Systems*. Plenum Press, New York, NY, 1996
- [21] North American Electric Reliability Council, “NERC Disturbance Reports,” Tech. Rep., New Jersey, 1996–2003, [online]. Available: [www.nerc.com](http://www.nerc.com).
- [22] MacCalley J. “Operational defense of power system cascading sequences: probability, prediction & mitigation,” Power Systems Engineering Research Center (PSerc) Seminars, Oct. 2003, [online]. Available: [www.pserc.org](http://www.pserc.org).
- [23] Makarov Y.V., Reshetov V.I., Stroev A., and Voropai I., “Blackout prevention in the United States, Europe, and Russia,” Proceedings of the IEEE, vol. 93, no. 11, pp.942 – 1955, Nov. 2005.
- [24] Milli L., Qiu Q., Phadke A.G., “Risk Assessment of Catastrophic Failures in Electric Power Systems”, Int. J. Critical Infrastructures, Vol.1, No.1, pp38-63, 2004.

IMPROVING BUFFALO CITY'S SUB-TRANSMISSION RELIABILITY  
REFERENCES

- [25] Deng S., Meliopoulos S., Mount T., etc. "Modeling Market Signals for Transmission Adequacy Issues: Valuation of Transmission Facilities and Load Participation Contracts in Restructured Electric Power Systems", Power Systems Engineering Research Center, Feb 2007, pp 1.
- [26] Karakash J.J., *Transmission Lines and Filter Networks* (1st ed.), Macmillan, 1950
- [27] Bergen A. and Vittal V., *Power Systems Analysis*, Prentice Hall, 2<sup>nd</sup> Ed., New Jersey, 2000.
- [28] Salimun N. B. "Phase Coordinates in Faulted Power System Analysis", Universiti Teknologi Malaysia. Master Thesis, 2010.
- [29] Horak J., "A Derivation of Symmetrical Component Theory and Symmetrical Component Networks," Georgia Tech Protective Relaying Conference, April 2005. Available at [www.basler.com](http://www.basler.com).
- [30] Phadke A. G. and Thorp J. S., "Expose hidden failures to prevent cascading outages," IEEE Computer Applications in Power, vol. 9, no. 3, pp. 20–23, July 1996.
- [31] Westinghouse Electric Corporation, *Applied Protective Relaying*, 1982.
- [32] WSCC Relay Work Group, "Review of WSCC Disturbances—1998-1999,"
- [33] R. Billinton, M. Fotuhi-Firuzabad, and T. S. Sidhu, "Determination of the Optimum Routine Test and Self-Checking Intervals in Protective Relaying Using a Reliability Model", IEEE Transactions on Power Systems, Vol. 17, No.3, August 2002.
- [34] Billinton R., Allan R. N., "Reliability Evaluation of Engineering Systems" 2nd Edition, Plenum Press, 1996.
- [35] Allan D. M., "Technical Challenges of an Aging Power System in a Deregulated Industry", Australasian Universities Power Engineer Conference (AUPEC2(04),26-29 sept. 2004.Brisbane, Australia.
- [36] Asgarpoor S. & Mathine M. J., "Distribution System Reliability evaluation with aging Equipment" Electric power system Research 33 (1995)133-137.

IMPROVING BUFFALO CITY'S SUB-TRANSMISSION RELIABILITY  
REFERENCES

- [37] Brown R. E. & Willis H. L., "The Economics of Aging Infrastructure", IEEE Power & Energy Magazine, Vol A, No.3.PP36-43,May/June 2006.
- [38] Dominelli N., Rao A. and Kundur P.; "Extensionand Condition assessment ". IEEE Power & Energy Magazine, Vol A, No.3, PP24-35, May/June 2006.
- [39] Wenyuan U., Vaahedi E. and Choudhary P. "power system equipment aging ",IEEE Power & Energy Magazine ,Vol A ,No.3,PP52-58, May/une 2006.
- [40] Shrivastava P. K., CORE International Inc., "Maintenance Philosophy, Policy and Strategy", Best practices in Distribution systems O&M, DRUM training program.
- [41] Siththumwat A, Tomsovic K., Soudi F., "Optimizing Maintenance Resources in Distribution Systems with Limited Information" August 2000.
- [42] Phadke A. G. and Thorp J. S., "Expose hidden failures to prevent cascading outages," IEEE Computer Applications in Power, vol. 9, no. 3, pp. 20–23, July 1996.
- [43] Jonsson M. and Daalder J. E., "An adaprive scheme to prevent undesirable distance protection operation during voltage instability," IEEE Trans. Power Delivery, vol. 18, no. 4, pp. 1174–1180, Oct. 2003.
- [44] Tan J. C., Crossley P. A., McLaren P. G., Gale P. F., Hall I., and Farrell J., "Application of a wide area backup protection expert system to prevent cascading outages," IEEE Trans. Power Delivery, vol. 17, no. 2, pp. 375–380, Apr. 2002.
- [45] Horowitz S. H., Phadke A. G., and Thorp J. S., "Adaptive transmission system relaying," IEEE Trans. Power Delivery, vol. 3, no. 4, pp. 1436–1445, Oct. 1988.
- [46] Rockefeller G. D., Wagner C. L., Linders J. R., Hicks K. L., and Rizy D. T., "Adaptive transmission relaying concepts for improved performance," IEEE Trans. Power Delivery, vol. 3, no. 4, pp. 1446–1458, Oct. 1988.
- [47] Phadke A. G. and Horowitz S. H., "Adaptive relaying," IEEE Computer Applications in Power, vol. 3, no. 3, pp. 47–51, July 1990.
- [48] Working Group C6 of the System Protection Subcommittee of the IEEE Power System Relaying Committee, "Wide area protection and emergency control," Tech. Rep., 2002, [online]. Available: [www.pes-psrc.org](http://www.pes-psrc.org).
- [49] Bertsch J., Carnal C., Karlson D, McDaniel J., and Vu K., "Wide-area protection and power system utilization," Proceedings of the IEEE, vol. 93, no. 5, pp. 997–1003, May 2005.

IMPROVING BUFFALO CITY'S SUB-TRANSMISSION RELIABILITY  
REFERENCES

- [50] Kakagi T., Bab J., Uemura K., and Sakaguchi T., "Fault protection based on traveling wave theory – Part 1: Theory," in Proc. IEEE PES Summer Meeting, Mexico City, Mexico, July 1977, vol. 3, pp. 750–753.
- [51] Dommel H. W. and Michels J. M., "High speed relaying using traveling wave transient analysis," in Proc. IEEE PES Winter Meeting, New York, Jan./Feb. 1978, vol. 3, pp. 214–219.
- [52] Chamia M. and Liberman S, "Ultra high speed relay for EHV/UHV transmission lines – development, design and application," IEEE Trans. Power Apparatus and Systems, vol. 97, pp. 2104–2112, 1978.
- [53] Johns A. T., "Ultra-high speed directional comparison technique for the protection of EHV transmission lines," IEE Proceedings, Part C, vol. 127, pp. 228–239, 1980.
- [54] Vitins M., "A fundamental concept for high speed relay," IEEE Trans. Power Apparatus and Systems, vol. 100, pp. 163–168, 1981.
- [55] Crossely P. A. and McLaren P. G., "Distance protection based on traveling waves," IEEE Trans. Power Apparatus and Systems, vol. 102, pp. 2971–2983, 1983.
- [56] Christopoulos C., Thomas D., and Wright A., "Scheme, based on traveling waves for the protection of major transmission lines," IEE Proceedings, Part C, vol. 135, pp. 63–73, 1988.
- [57] Aggarwal R. K., Johns A. T., Song Y. H., Dunn R. W., and Fitton D. S., "Neural-network based adaptive single-pole auto reclosure technique for EHV transmission systems," IEE Proc. Gener, Trans, Distrib, vol. 14, no. 2, pp. 155–160, Mar. 1994.
- [58] Dalstein T. and Kulicke B, "Neural network approach to fault type classification for high speed protective relaying," IEEE Trans. Power Delivery, vol. 10, no. 2, pp. 1002–1011, Apr. 1995.
- [59] Sidhu T. S., Singh H., and Sachdev M. S., "Design, implementation and testing of an artificial neural network based fault direction discriminator for protecting transmission lines," IEEE Trans. Power Delivery, vol. 10, no. 2, pp. 697–706, Apr. 1995.

IMPROVING BUFFALO CITY'S SUB-TRANSMISSION RELIABILITY  
REFERENCES

- [60] Dalstein T, Friedrich T., Kulicke B., and Sobajic D., "Multi neural network based fault area estimation for high speed protective relaying," IEEE Trans. Power Delivery, vol. 11, no. 2, pp. 740–747, Apr. 1996.
- [61] Kezunovic M. and Rikalo I., "Detect and classify faults using neural nets," IEEE Computer Applications in Power, vol. 9, no. 4, pp. 42–47, Oct. 1996.
- [62] Song Y. H., Xuan Q. X., and Johns A. T., "Comparison studies of five neural network based fault classifiers for complex transmission lines," Electric Power Systems Research, vol. 43, no. 2, pp. 125–132, Nov. 1997.
- [63] Johns A. T. and Agrawal P., "New approach to power line protection based upon the detection of fault induced high frequency signals," IEE Proc. Gener, Trans, Distrib, vol. 137, no. 4, pp. 307–313, July 1990.
- [64] Johns A. T., Aggarwal R. K., and Bo Z. Q., "Non-unit protection technique for EHV transmission systems based on fault-generated noise, Part 1: Signal measurement," IEE Proc. Gener, Trans, Distrib, vol. 141, no. 2, pp. 133–140, Mar. 1994.
- [65] Johns A. T., Aggarwal R. K., and Bo Z. Q., "Non-unit protection technique for EHV transmission systems based on fault-generated noise, Part 2: Signal processing," IEE Proc. Gener, Trans, Distrib, vol. 141, no. 2, pp. 141–147, Mar. 1994.
- [66] Johns A. T., Aggarwal R. K., and Bo Z. Q., "Non-unit protection technique for EHV transmission systems based on fault-generated noise, Part 3: Engineering and HV laboratory testing," IEE Proc. Gener, Trans, Distrib, vol. 143, no. 3, pp. 276–282, May 1996.
- [67] Bo Z. Q., Aggarwal R.K., Johns A. T., Li H. Y., and Song Y. H., "A new approach to phase selection using fault generated high frequency noise and neural networks," IEEE Trans. Power Delivery, vol. 12, no. 1, pp. 106–115, Jan. 1997.
- [68] Asgarpoor S., Doghman M., "A Maintenance Optimization Program for Utilities Transmission and Distribution Systems"
- [69] Endrenyi j., *Reliability Modeling in Electric Power Systems*. John Wiley & Sons, New York, NY, 1978.
- [70] Billinton R., Allan R., and Salvaderi L., (editors). *Applied Reliability Assessment in Electric Power Systems*. IEEE Press, New York, NY, 1991.

IMPROVING BUFFALO CITY'S SUB-TRANSMISSION RELIABILITY  
REFERENCES

- [71] Billinton R., and Allan R., *Reliability Evaluation of Power Systems*. Plenum Press, New York, NY, 1996.
- [72] Hirst E., and Kirby B., "Ancillary Services: The Neglected Feature of Bulk Power Markets". *Electricity Journal*, Vol. 11, No. 3, Elsevier Science, April 1998, pp. 50-57.
- [73] Federal Energy Regulatory Commission. *Promoting Wholesale Competition Through Open Access Non Discriminatory Transmission Services*. Order No. 888, April 1996.
- [74] North American Electric Reliability Council. *NERC Operating Manual*. Princeton, NJ, Dec. 1997.
- [75] Hirst E., and Kirby B. "Technical and Market Issues for Operating Reserve". *Electricity Journal*, Vol. 12, No.2, Elsevier Science, March 1999, pp. 36-48.
- [76] Allan R. "Concepts of Data for Assessing the Reliability of Composite Systems". IEEE Tutorial Course - *Reliability Assessment of Composite Generation and Transmission Systems*, IEEE Power Engineering Society. IEEE Publishing Services, New York, NY, pp. 14-20, 1989.
- [77] Ringlee R. "Thoughts on the Applications of Composite System Reliability Methods – Cost Benefit Analysis". IEEE Tutorial Course - *Reliability Assessment of Composite Generation and Transmission Systems*, IEEE Power Engineering Society. IEEE Publishing Services, New York, NY, pp. 56-61.
- [78] Power Factory User's Manual DIgSILENT PowerFactory (2008) Version 14.0, DIgSILENT GmbH, Gomaringen, Germany, 1989.
- [79] Glover J. D. and Sarma M., "Power System Analysis and Design", Second Edition, PWS Publishing Company, Boston, 1994.
- [80] AS 3851 – 1991 The calculation of short circuit currents in three phase a.c. systems, Standards Australia, 1991.
- [81] Markovic D. M., "Fault Analysis in Power Systems by Using the Fortescue Method", TESLA Institute, 2009.
- [82] Gonen T., "Electric Power Transmission System Engineering, Analysis and Design", Crc Press Taylor and Francis Group.

## APPENDICES

### APPENDIX A: Common-cause failure model

Appendix A is a model of common cause of failure on power system component. Four major stages, each of which contains a number of steps, form the procedural framework for the analysis. Figure A.1 summarizes the main elements of the framework. Some comments are given below, including the references to the sections of the present guidelines, which specifically cover the underlying concepts. For detailed definitions, we refer to the original reference (Mosleh et al., 1988, 1989).

**Stage 1** - System Logic Model Development is covered in the general guidelines for PSA (IAEA, 1992). This stage is a prerequisite for common-cause failure analysis. Aspects related to the interface between this stage and the subsequent ones will be touched upon.

**Stage 2** - Identification of Common-Cause Component Groups focuses on the screening process and is critical for definition of the scope of the detailed analysis.

**Stage 3** – Common-Cause Modelling and Data Analysis - A definition of common-cause failure is defined as multiple failures of components from shared root causes. The incorporation of common-cause events in the logic model is achieved by a straightforward modification of its structure. The selection of models for quantification of CCF contributions and the analysis and manipulation of data constitute the tasks that call for most guidance.

**Stage 4** - System Quantification and Interpretation of Results synthesises the key output of the previous stages leading to quantification of system failure probability. In addition, uncertainty and sensitivity analyses provide additional perspective for interpretation of results.

Stage 1 - System Logic Model Development

Steps

1.1 System Familiarization

1.2 Problem Definition

1.3 Logic Model Development
Stage 2 - Identification of Common-Cause Component Groups  Steps  2.1 Qualitative Analysis  2.2 Quantitative Screening
Stage 3 – Common-Cause Modelling and Data Analysis  3.1 Definition of Common-Cause Basic Events  3.2 Selection of Probability Models for Common-Cause  Basic Events  3.3 Data Classification and Screening  3.4 Parameter Estimation
Stage 4 - System Quantification and Interpretation of Results  4.1 Quantification  4.2 Results Evaluation and Sensitivity Analysis  4.3 Reporting

**Figure A.1** Procedural framework for common-cause failure analysis

**APPENDIX B: Outages and the impact on consumers**

In this appendix, a brief description of the impact consumers experienced when power outage occur on power system network is presented.

Electric service interruptions occur when system capacity is exhausted, aging transmission equipment fails to operate due to lack of planned maintenance or is insufficient to meet the system load levels. Electricity supply interruption could also occur in the event of a fault on the network system and this phenomenon is either a minor or a major scenario depending on the magnitude of the fault. During these periods of inadequacy, outage costs will be borne by the utility, its customers and perhaps, by the entire society. The utility outage costs include loss of revenue, loss of future sales, and increased repair expenditure and maintenance expenditure. These costs usually form only a small part of the total outage costs. The greater part is that borne by the consumers. The outage costs depend on many factors and situations, some of which are discussed in the following sections. The perceived costs of an electric outage and the point in time when a consumer would like to buy electric energy but is unable to do so, affects the problem of estimating outage costs. Since there are different classes of consumers, each will tolerate loss of service differently.

A residential consumer may suffer a great deal of hardship if an outage occurs during a hot summers day or while he is engaging in domestic activities but it may be of little inconvenience to a commercial user who is forced to close until power is restored. In addition, an outage may cause a great loss to an industrial user if it occurs during the time of the production process. Therefore, consumers do not perceive service interruption to the same degree of hardship. The outage costs to a particular consumer also depend on the alternatives available to that individual at the time of service interruption. If the outages are not expected, the consumer may have very limited alternatives and may incur a great loss. On the other hand, if an adequate warning is given, the losses may be averted or mitigated.

In addition, as an outage continues or spreads to a larger subset of society, the society cost will tend to increase and will include such indirect costs as effects from

IMPROVING BUFFALO CITY'S SUB-TRANSMISSION RELIABILITY  
REFERENCES

anxiety, loss of products, food spoilage, health hazards, etc. The major aspect of outage costs estimation is to assess the worth of power system reliability in order to compare it with the cost of power system to establish an appropriate system reliability level. In this regard, it is important to realise that, while the evaluation of power system reliability has become a well-established practice over the last decade, the assessment of the worth of reliability or conversely, the estimation of costs of losses that result from system unreliability, is still immature. The major reason for this is that the quantification of interruption costs is an intricate and often a subjective task.

### **APPENDIX C: Protections in electric power systems**

In this appendix a brief summary of how protections are designed and how they function is given. The very important distance protections and their operating principles are discussed. Some special protections and system wide protections that are of relevance for power system stability is briefly reviewed.

Different types of protections are installed to protect the equipment in an electric power system. Their task is to disconnect failed or overloaded equipment or parts of the system to avoid unnecessary damages on equipment and personnel. The purpose is also to limit the impact of failures on the parts of the system that have not failed. Special types of protection are the “system protections”. Their task is to prevent collapse (black out) of the system or parts of the system.

An intensive development of protections based on modern information technology is going on both regarding hardware and software. On the hardware side microprocessors have been used over a long time to implement different functions in the protections, and with the recent developments more and more complicated functions can be implemented in a reliable way. Powerful methods like signal processing, state estimation, and “artificial intelligence”, are being integrated into the protections. In general the functions which earlier were handled with separate relays are increasingly being integrated with other functional units for control and supervision. Furthermore, more complicated criteria for activation of protections can be applied. The interested reader is referred to the literature for further information. The summary here is concentrated on misoperation of protections devices.

#### **C.1 Design of protections**

A protection for an electric power system comprises the following parts:

- Measurement device with current- and/or voltage transformers and other sensors measuring the relevant quantities.

IMPROVING BUFFALO CITY'S SUB-TRANSMISSION RELIABILITY  
REFERENCES

- Relay which when certain conditions are fulfilled sends signals to a circuit breaker or another switching device. This relay was earlier a separate unit, but can in modern protections be a part of a larger unit for protection, supervision and control.
- Circuit breakers which execute the given instruction(s) from the relay.
- Telecommunication system is mainly used at distance (line) protections to get a faster and more reliable performance.
- Power supply systems which shall secure the power supply to the protection system, even with faults in the system.

The requirements on a protection system are that they should be dependable, secure, selective, sensitive, and fast.

- Dependability means that the protection should react and do its action when a fault occurs for which it is designed to react for. To achieve desired dependability double or even triple sets of certain parts of the protection or of signal paths might be needed. Malfunctions can be divided into not occurring or unwanted operations. Normally none occurring operations are more serious malfunctions than unwanted ones.
- Security means that the protection should not react when no fault occurs or when a fault for which its not intended to react occurs.
- Selectivity implies that not more than necessary pieces of equipment and apparatuses are disconnected to isolate a fault.
- Sensitivity is needed to detect failures which cause small fault currents, e.g. high impedance faults. This implies that the risk for misoperations increases at “small” disturbances, e.g. at energisation of transformers, or at high load operation but normal operation.
- The protection should react fast to secure that damages on persons and equipment are prevented or limited.

The protections are often classified according to the object that they protect. An example is shown in Figure C.1. If a failure occurs within an indicated area in

Figure C.1 this area should be isolated from the rest of the network. Many of the protections which protect separate pieces of equipment or parts of a system with occupy a limited physical area are so called current differential protections. These protections measure the difference between two currents, which in normal operation should be equal, and the protection is activated if this deviation exceeds a predetermined value. Both differences in amplitude and phase can trigger the relay. The principle for a current differential protection is shown in Figure B.2.

## C.2. Distance Protections

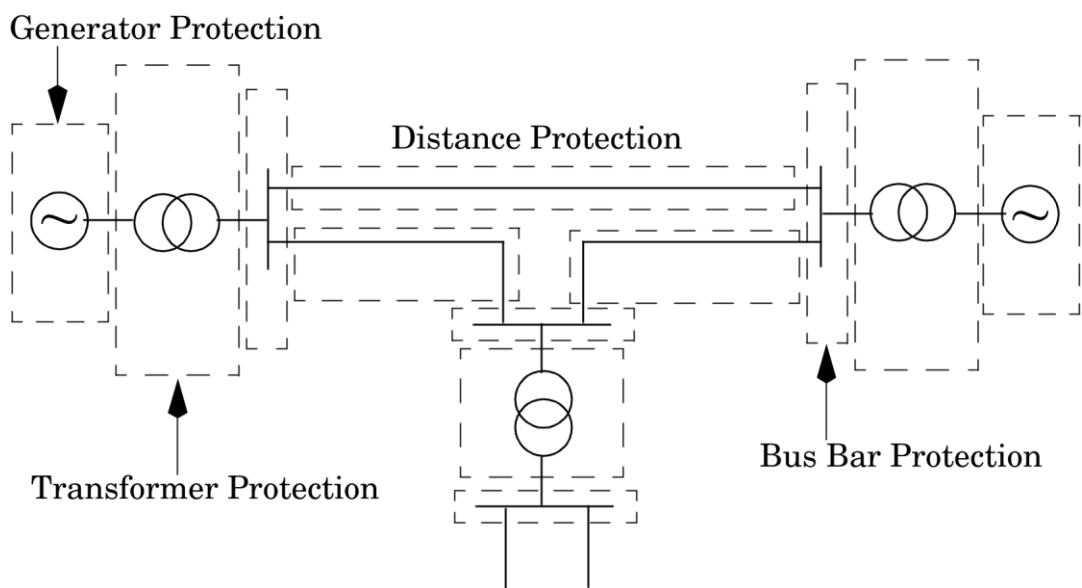

**Figure C.1:** The different protection zones in a power systems.

## C.2 Distance protections

### C.2.1 General principles

So called distance protections are important protections concerning stability and dynamics in a power system. Their task is to disconnect faulted lines or cables. Since large parts of the power system consist physically of lines and these are exposed to different disturbances, e.g. lightning strokes, down falling trees etc., it is important that those faults can be isolated to minimise the impact on the rest of the system. The most common faults are ground (earth) faults, i.e. short circuits

between two or more phases and ground (shunt faults). Also interruptions in the lines can occur (series faults). The operating principle of the distance protection is shown in Figure C.3.

Current and voltage are measured in both ends of the line and from these an apparent impedance can be calculated:  $Z = U/I$ . In normal operation this impedance varies within a certain area (large and almost resistive values on  $Z$ ), but if a fault occurs it will drastically change. The given value depends on where on the line the failure occurs, and from system parameters as line data and short circuit capacity, it can be calculated where the fault has occurred. For each distance protection there are several protection zones defined in the  $Z$  plane according to Figure C.4. A low value on  $Z$  implies that the fault is close to the measurement. From line data and short circuit capacity

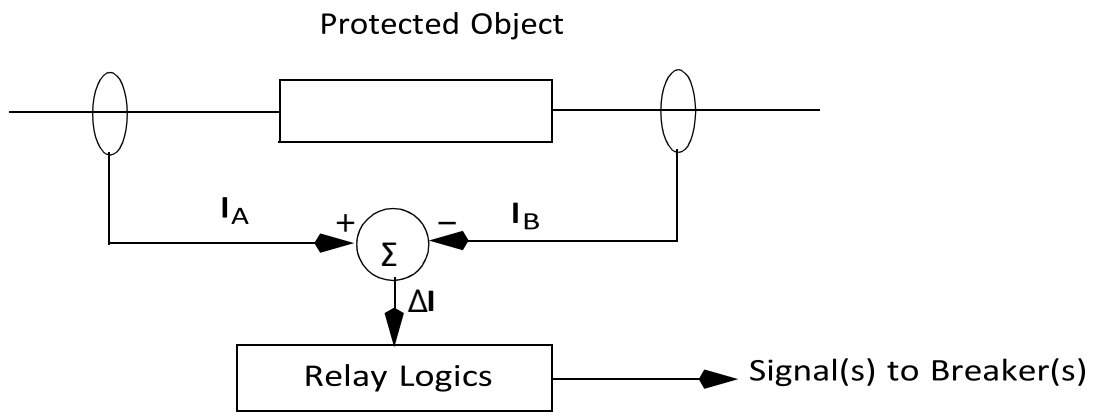

**Figure C.2:** Principles of a current differential protection.

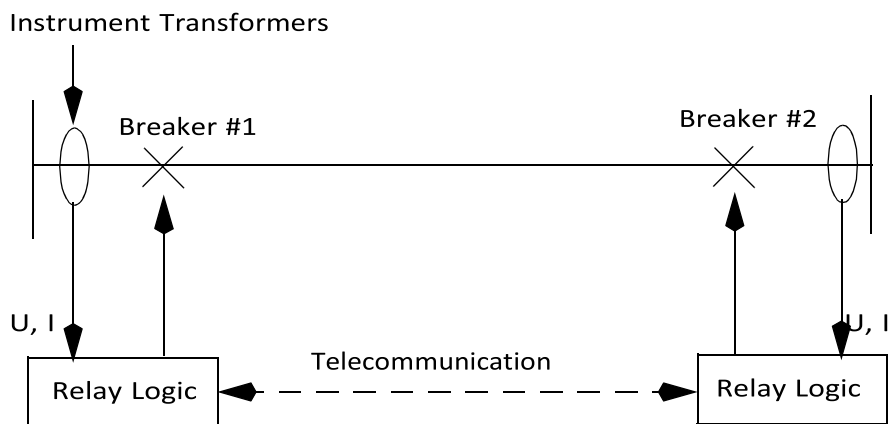
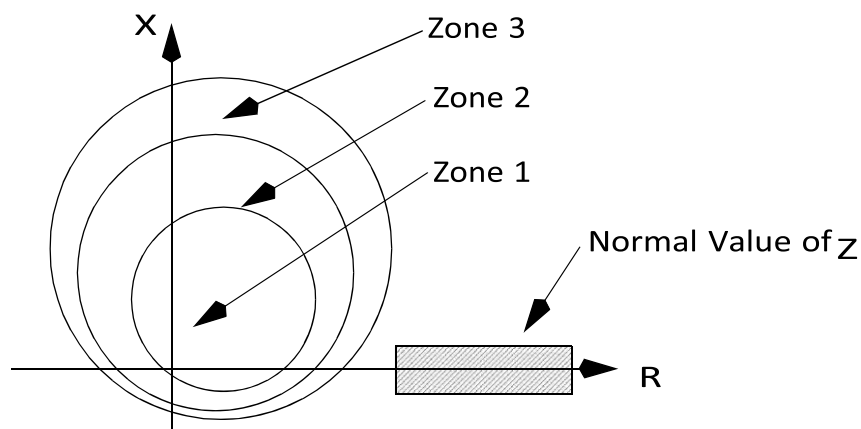

**Figure C.3:** The operating principle of a distance protection.

it can then be decided if the fault is in the protected line, within Zone 1, or not. If that is the case, a trip order is given to the breaker at the same station within some milliseconds, typically 10 ms, after  $Z$  has reached Zone 1. At the same time a trip order is given to the breaker in the other end of the line. This latter trip order is not needed for isolation of the fault, if the protection system in the other end works as it should, but this trip order (transfer trip) increases the security in the system.

If the measured value on  $Z$  is in Zone 2 or 3, it implies that the fault is outside the actual line. This implies that neither breaker 1 nor 2 in Figure C.3 shall be opened. If the breakers, which according to the protection plane should isolate the fault, are not operated by some reason, other breakers which are further away from the fault must isolate it. These secondary

#### C.2. Distance Protections



**Figure C.4:** Different zones in a distance protection.

breakers will be used first after it is clear that the primary breakers have not isolated the fault. Therefore if,  $Z$  is in Zone 2, the breaker does not get the trip order until typically some hundred milliseconds have passed.

To coordinate and tune the settings of the protections to give a fast, reliable, sensitive and selective protection system is a complicated and an important task in an electric power system. In modern protection systems different areas can be defined according to Figure C.4 with in principal arbitrary geometric shapes, which

IMPROVING BUFFALO CITY'S SUB-TRANSMISSION RELIABILITY  
REFERENCES

facilitates the work. A plan comprising the different areas of protections and time settings is usually called a selectivity plan. The work to establish a selectivity plan is often very time consuming because it should be appropriate for every feasible state of operation, i.e. for different numbers of generators and lines connected and also at different load levels. Often trade-offs must be made to reach acceptable results.

## APPENDIX D: Maintenance strategies

In general, maintenance is either planned or unplanned as shown in Figure D1. Corrective maintenance is a reactive strategy that is unplanned and is carried out after failure has occurred. The intention is to restore an item to a state that can perform its required function. Planned maintenance strategies are proactive in nature and can be divided into two groups: Preventive and Condition Monitoring. Preventive maintenance, sometimes called scheduled, is a maintenance carried out at regular intervals.

### D.1 Maintenance on transmission network

Maintenance on primary transmission lines has been a major challenge with regard to the adaption of planned preventative Maintenance (PPM) or reliability centred maintenance (RCM) strategy. Power outages become eminent when the utility company has no planned maintenance programme in place.

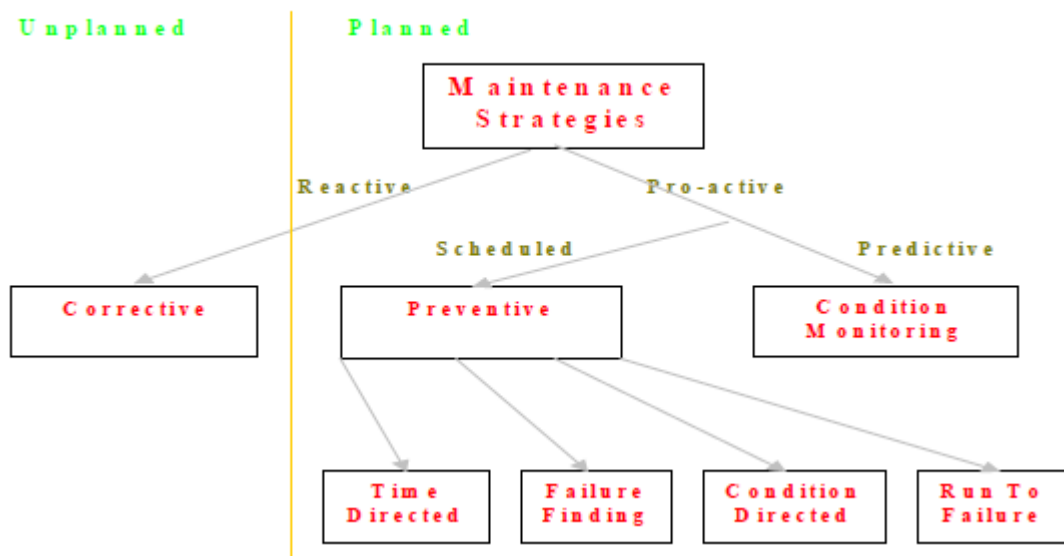

**Figure D.1:** Maintenance strategies

Unfortunately, BCMM has no planned maintenance strategy to mitigate regular power outages on the network. The maintenance practice available is reactive or corrective maintenance. Corrective maintenance is a reactive strategy that is unplanned and carried out after failure occurred. The intention is to restore an item to a state that can perform its required function. Corrective maintenance

performance does not effectively contribute to reliability improvement of the power system. Sections D.2 expound different proactive maintenance strategies (Reliability Centred Maintenance and Planned Preventive Maintenance) available for adaption by the BCMM maintenance team.

### **D.2 Reliability centred maintenance**

RCM, as has been mainly applied to nuclear power plants, often requires the largest amount of maintenance because of safety and environmental considerations. However, with these successful programs now operating, fossil power plants, and power transmission and distribution systems have recently been getting into the mix. Because these facilities faced lesser restrictive regulatory challenges, they should be able to apply the streamlines forms of RCM directly and much more easily, thus reducing the implementation costs.

RCM is a set of methods and tools aimed at helping a utility to determine the minimum set of preventive maintenance tasks necessary to address critical equipment failures appropriately without compromising service reliability. RCM is a structured process used to determine optimal maintenance requirements for equipment in a particular operating environment. It combines the strategies of corrective maintenance, preventive maintenance, predictive maintenance, and applies these strategies where each is appropriate, based on the consequence and frequency of functional failures. This combination produces a maintenance program that optimizes both reliability and cost effectiveness. For major pieces of equipment, such as power transformers, RCM may indicate that predictive maintenance is an attractive option, given the decreasing cost of sensor and diagnostic technology and the increasing cost of running the equipment to failure.

RCM is a condition-based maintenance program that focuses on preventing failures that are likely to be the most serious. RCM and Predictive Maintenance (PdM) analyses complement each other, and when performed concurrently, offer an excellent approach to maintenance optimisation. In the last few years, the sophistication of monitoring equipment on the market and the falling price of electronics and computers has made the on-site monitoring applications a cost-effective reality.

## **APPENDIX E: Procedures for DIgSILENT simulation and results**

The steps to take in order to perform load flow simulation is as follows:

### *Step 1. Data gathering*

- Single line diagram: Determine the interconnection of the network
- Maps: Determine location of substations and estimate line lengths, conceptualize loads
- Substations: Configuration of substation equipment i.e. power transformers, reactive devices, configuration of busbars, feeders, NEC
- Overhead lines: Line lengths, conductor types, special arrangement of conductors and earth wires
- Power transformers: Voltages, capacity, vector group, impedances, tap changer information, zero sequence impedance
- Loads: scenarios for high load, low load, summer load, winter load, load forecast.

### *Step 2. Build network in dig-silent power factory*

- Model Eskom point of supply at Buffalo 132 kV substation
- Stafford 132kV switchyard
- Stafford-Progress 132 kV lines 1, 2 & 3
- Progress-Stoney Drift 132 kV lines 1, 2 & 3
- Progress 132/11 kV substation
- Stoney Drift 132/33/11 kV substation
- Entry zero sequence data of transformers
- Entry NEC/R data
- Enter zero sequence and negative sequence data for overhead lines

### *Step 3. Run load flow:*

- Select method: IEC60909 or ANSI or IEC61361

**E1: Load flow simulation result of the existing network**

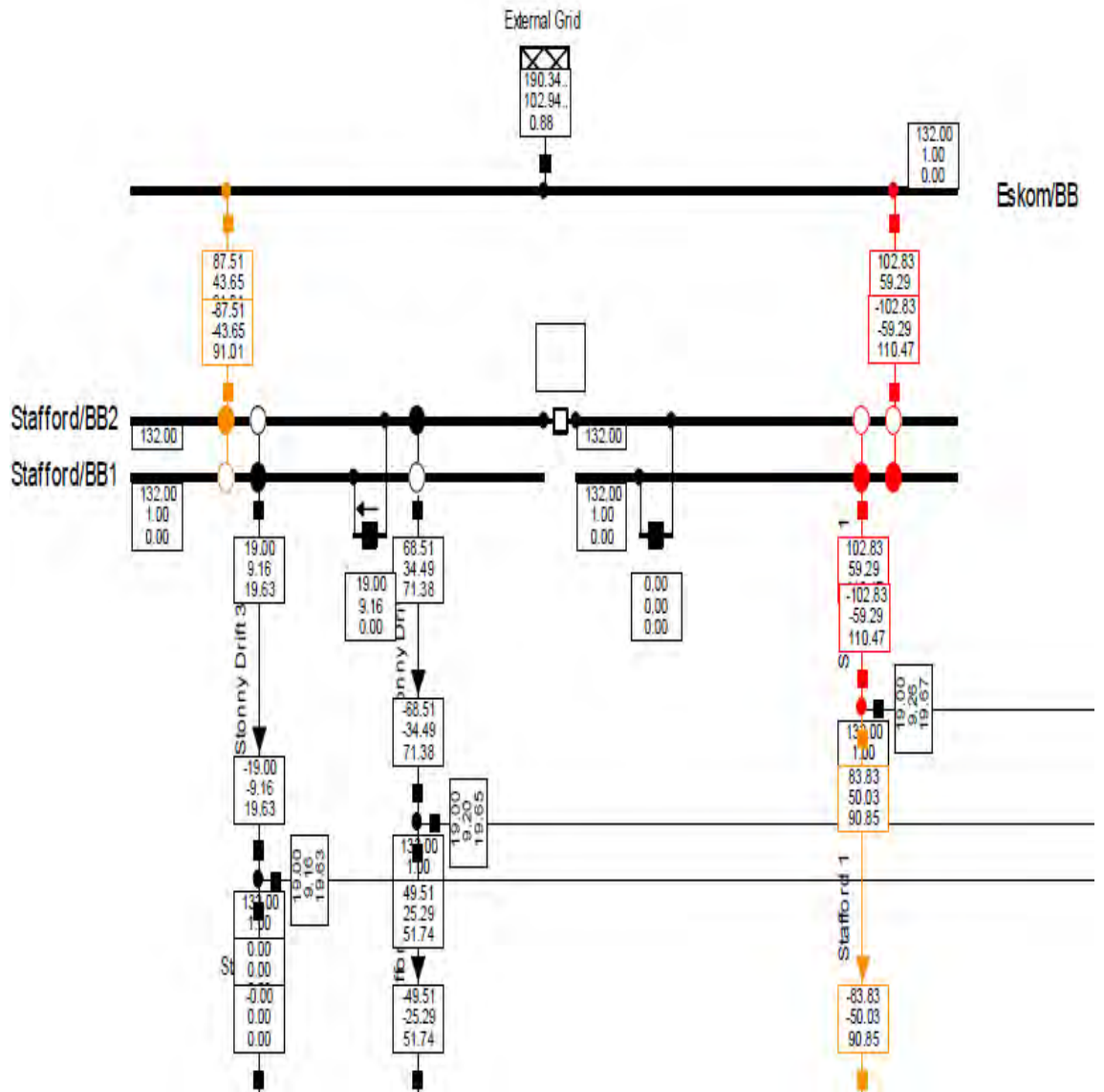

**Figure E.1:** Load flow simulation results at Eskom’s Buffalo substation and Stafford switchyard.

**E2: Simulation result of the existing network at Stoney Drift**

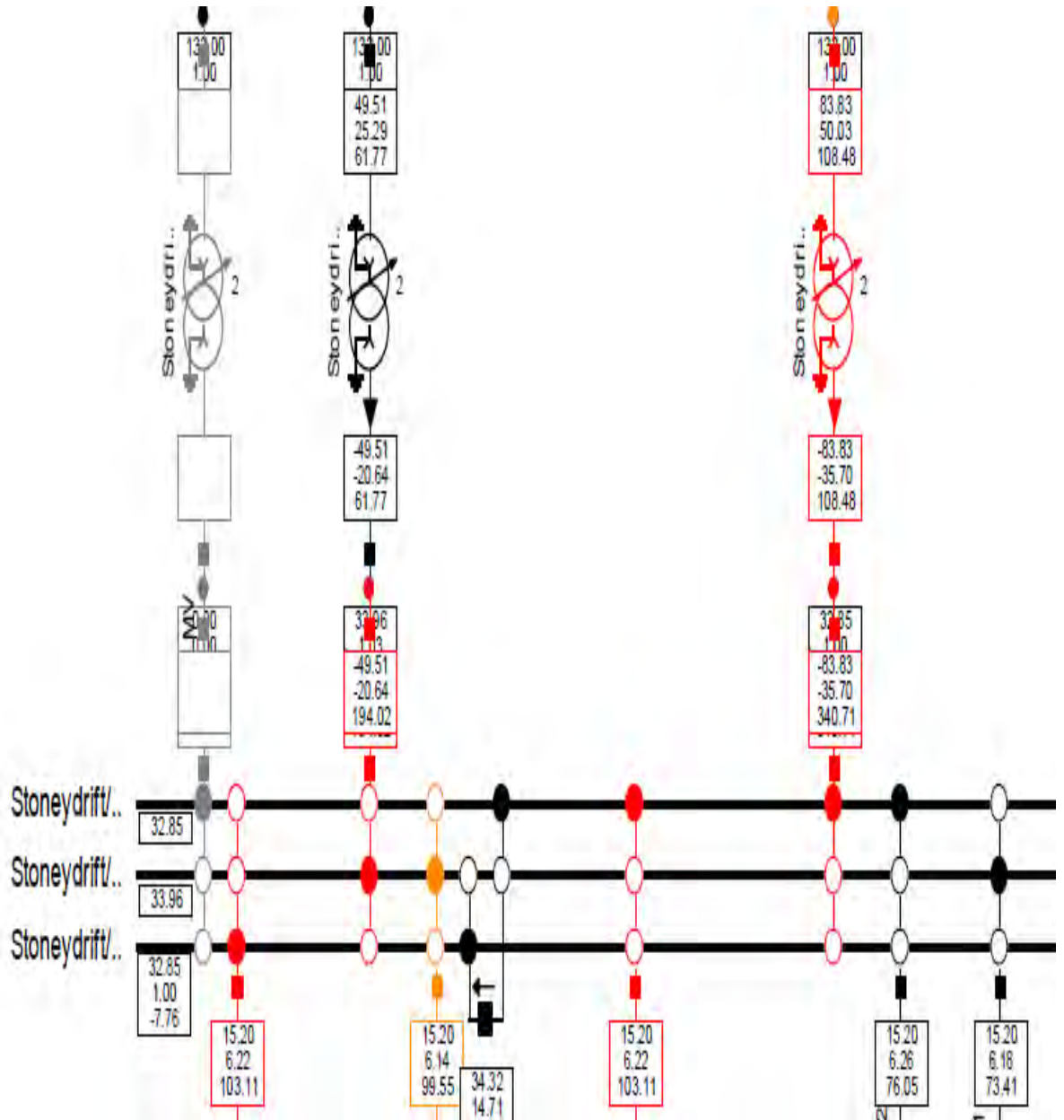

**Figure E.2:** Load flow simulation in Stoney Drift substation

**E3: Simulation result of the existing network at Progress.**

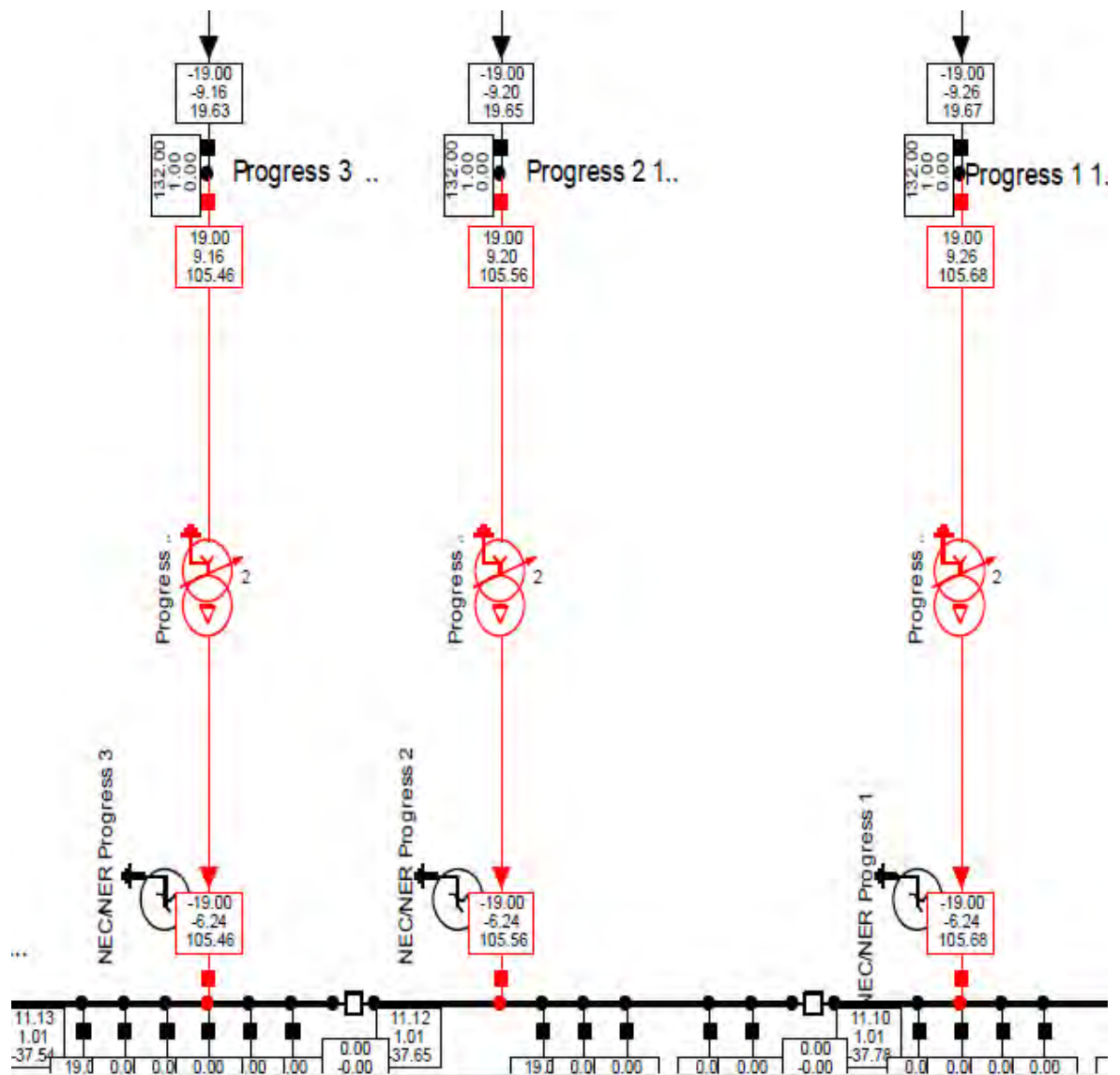

**Figure E.3:** Load flow simulation result at Progress substation.

**E4: Simulation result of the alternative (1) network at Stafford**

IMPROVING BUFFALO CITY'S SUB-TRANSMISSION RELIABILITY  
REFERENCES

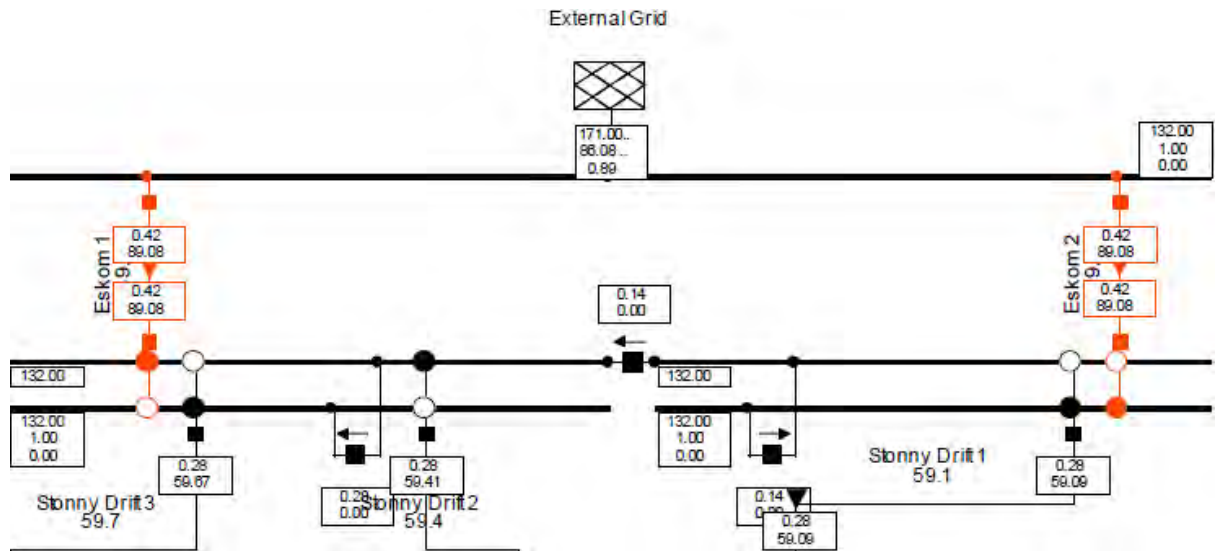

Figure E4: Alternative (1) network simulation at Stafford switchyard

E5: Simulation result of the alternative (1) network at Stoney Drift

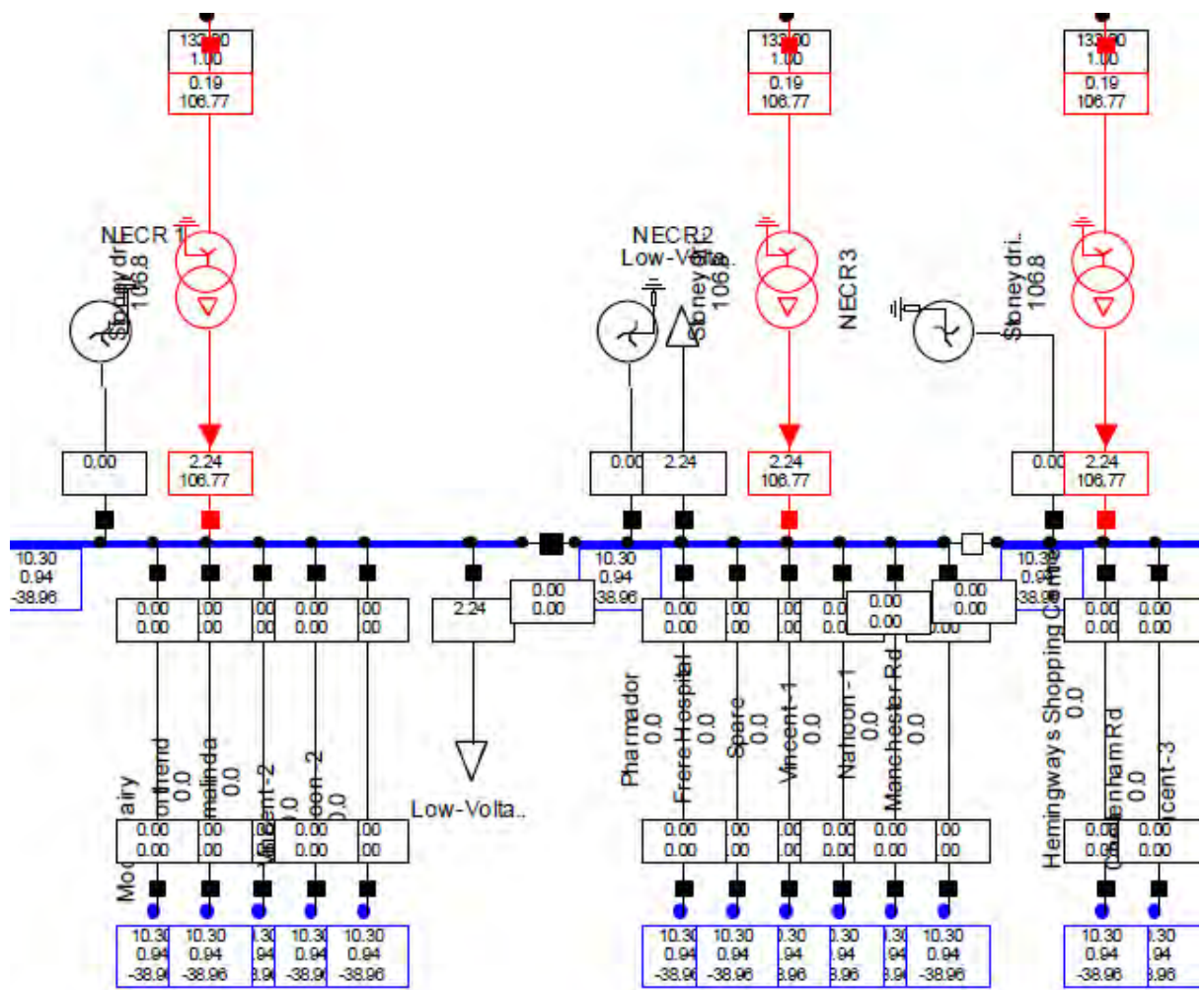
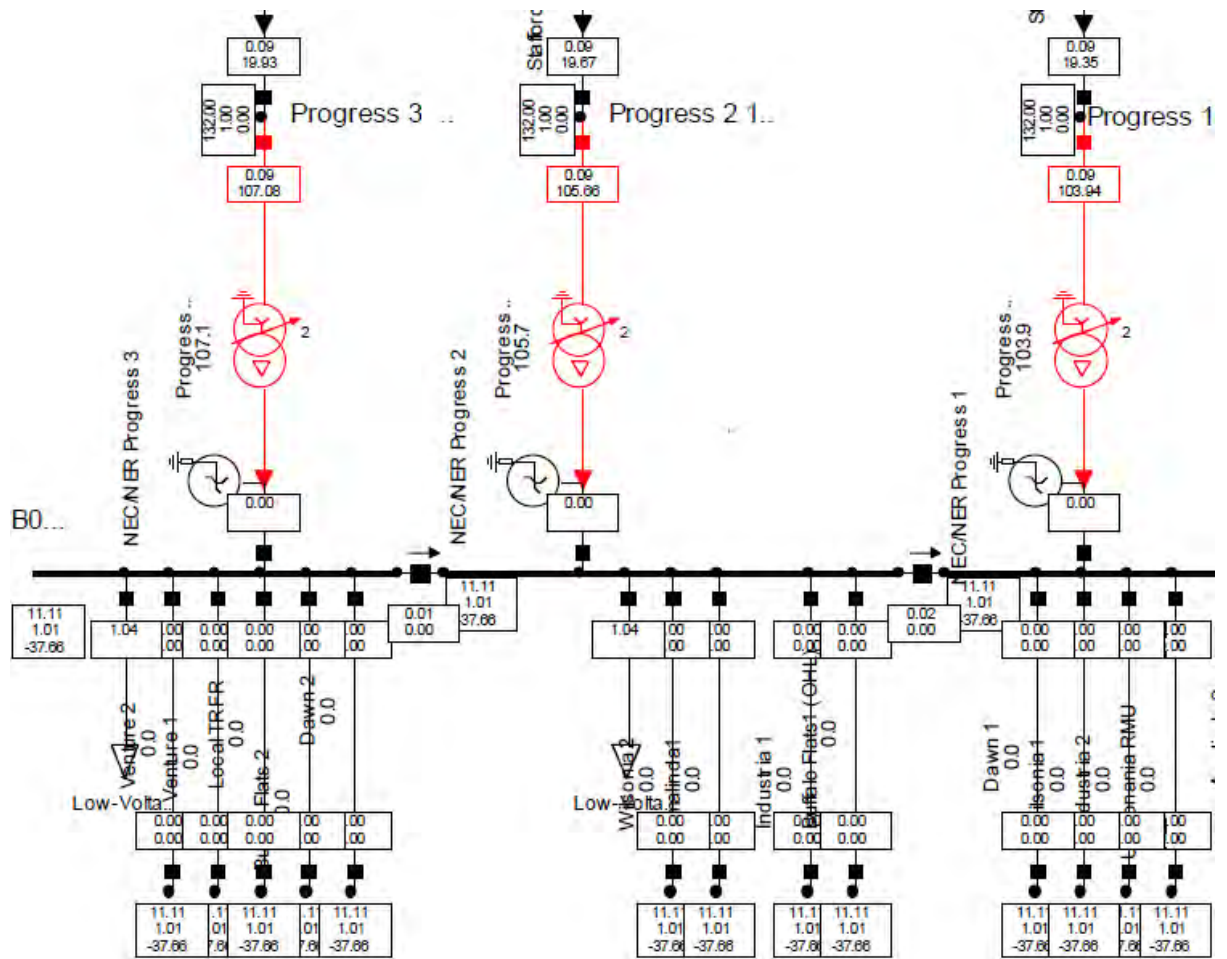

Figure E5: Alternative (1) network simulation at Stoney Drift substation

IMPROVING BUFFALO CITY'S SUB-TRANSMISSION RELIABILITY  
REFERENCES

**E6: Simulation result of the alternative (1) network at Progress**



**Figure E6:** Alternative (1) network simulation at Progress substation.

## **APPENDIX F: Fault level simulation and manual calculations**

### **F1: BCMM's manual fault level calculations of the existing network**

There are four methods and each of them can be utilized (infinite bus, ohmic, per unit and MVA) for fault level calculations, interestingly, they all arrive in the same answer with minor differences in decimal figures. For this manual calculation, the MVA method will be used.

### **F2: Assumptions commonly made in three phase fault**

The following assumptions are usually made in fault analysis in three phase transmission lines.

- All sources are balanced and equal in magnitude & phase
- Sources represented by the Thevenin's voltage prior to fault at the fault point
- Large systems may be represented by an infinite bus-bars
- Transformers are on nominal tap position
- Resistances are negligible compared to reactances
- Transmission lines are assumed fully transposed and all 3 phases have same  $Z$
- Loads currents are negligible compared to fault currents
- Line charging currents can be completely neglected.

The MVA method is a modification of the ohmic method. The first step is to convert the typical BCMM's single line diagram to the equivalent MVA single line diagram, and then to reduce the MVA single line diagram into a single MVA value at the point of fault. The component of a typical BC's single line are the utility source, transformers, buses and transmission lines. Figure F.1 shows a typical BCMM's single line diagram.

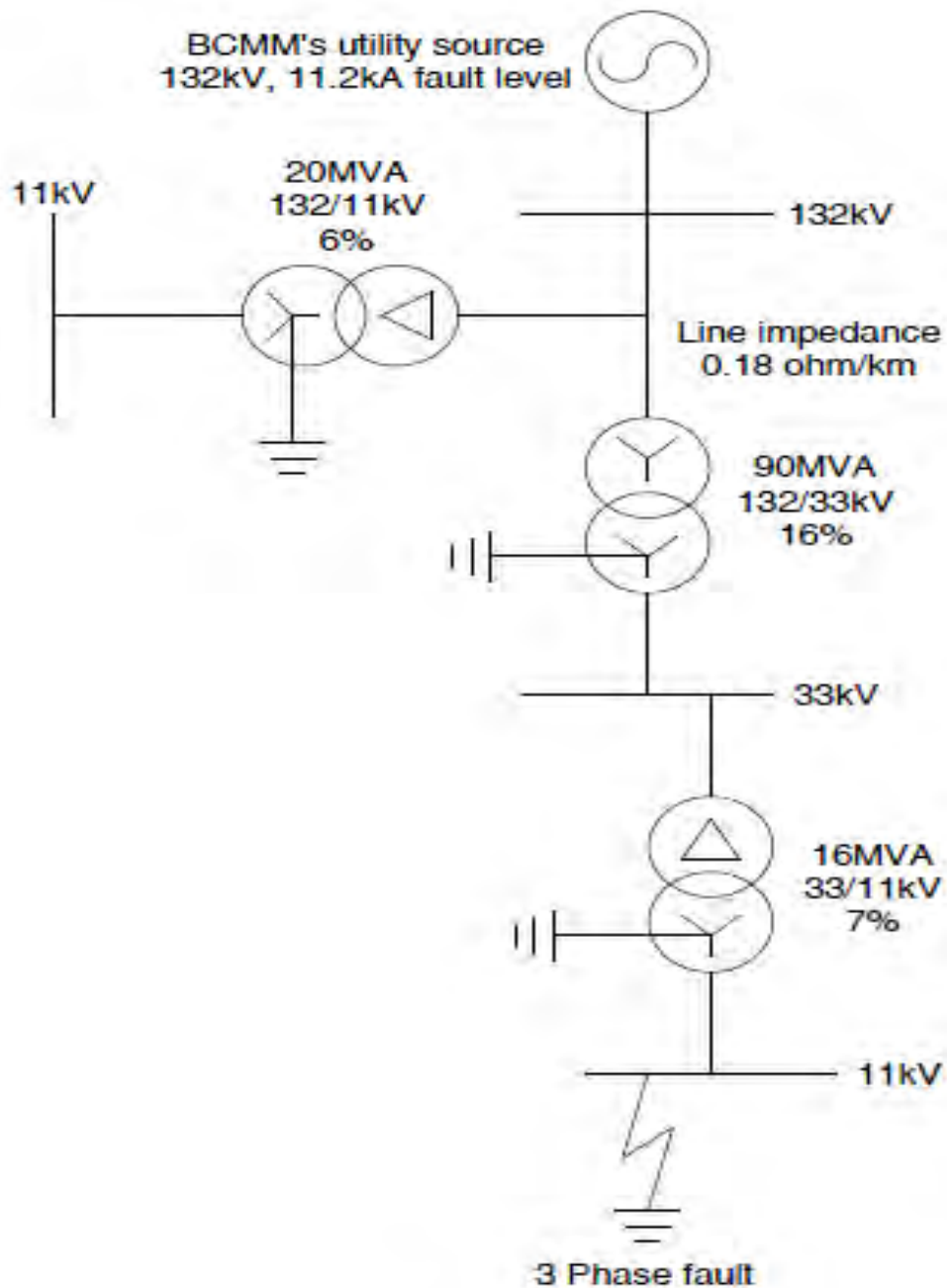

**Figure F.1:** Typical BCMM's primary power system single line diagram.

### **F3: Three phase MVA single line**

Figure F.4 is the equivalent MVA single line of the typical BCMM's network of Figure F.3. The next step is to reduce the MVA single line to single MVA value at the point of fault. The reduction uses basic mathematics, either "add up" the MVA values or "parallel up" the MVA values. Figure F.4 illustrates the steps for the

IMPROVING BUFFALO CITY'S SUB-TRANSMISSION RELIABILITY  
REFERENCES

reduction of the MVA single line to a single MVA value at the point of fault. The fault level for a 3 phase fault at 11 kV is 390 MVA or 17 kA.

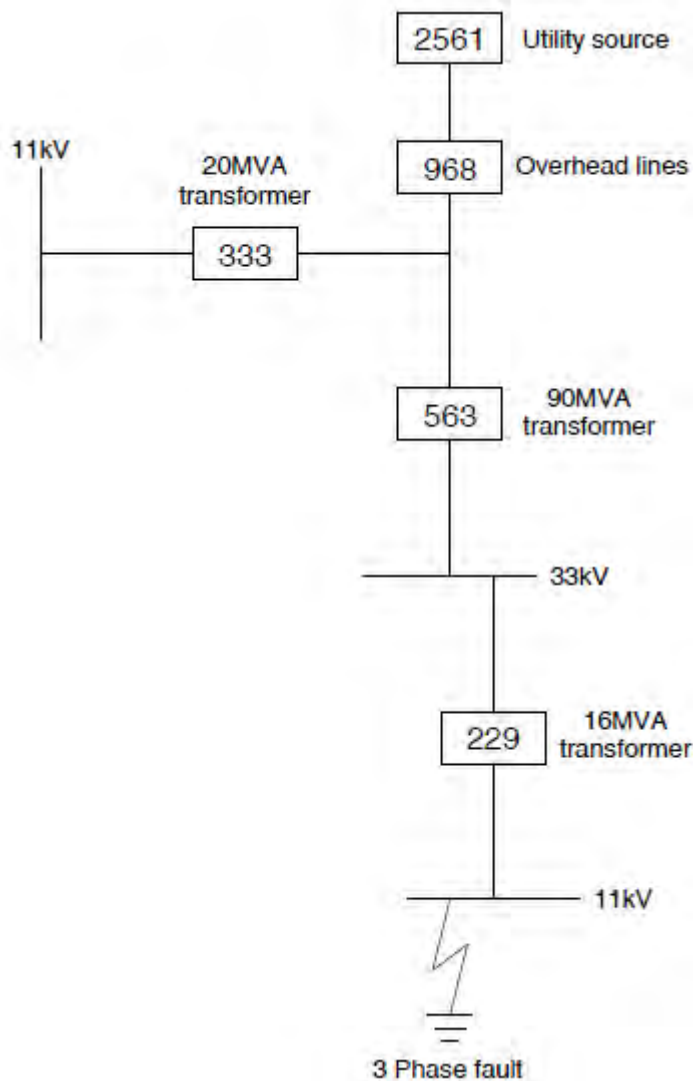

**Figure F.2:** BCMM's equivalent MVA value single line diagram

132 BCMM's source in Stafford switchyard

The MVA value is  $\sqrt{3 \times 132 \times 11.2} = 2561$  MVA (4.1)

Stafford switchyard has 11.2 kA fault level

20 MVA transformer in Progress substation

IMPROVING BUFFALO CITY'S SUB-TRANSMISSION RELIABILITY  
REFERENCES

The MVA value is  $\frac{20}{0.06} = 333 \text{ MVA}$  (4.2)

The transformer has 6% impedance

90 MVA transformer in Stoney Drift substation

The MVA value is  $\frac{90}{0.16} = 563 \text{ MVA}$  (4.3)

The transformer has 16% impedance

16 MVA transformer in chiselhurst substation

The MVA value is  $\frac{16}{0.07} = 229 \text{ MVA}$  (4.4)

The transformer has 7% impedance

132 kV Wolf overhead conductor

The MVA value will be  $\frac{V^2}{Z}$

Where V is the phase to phase voltage kV

Z is the per phase impedance in ohm.

The MVA value will be  $\frac{132 \times 132}{0.2} = 968 \text{ MVA}$  (4.5)

IMPROVING BUFFALO CITY'S SUB-TRANSMISSION RELIABILITY  
REFERENCES

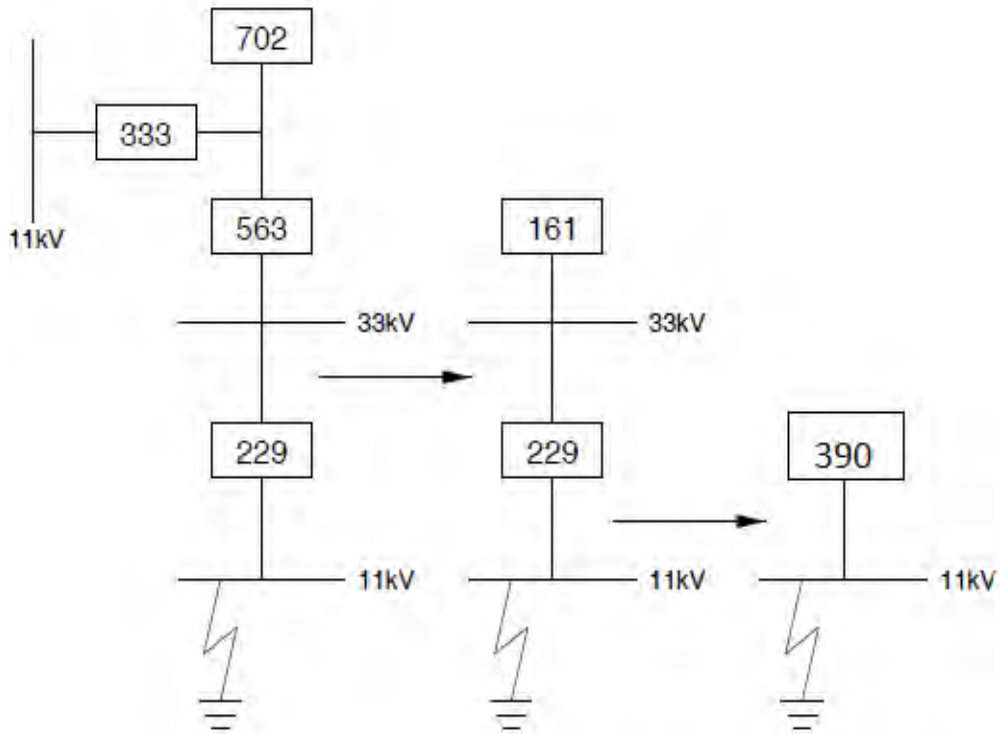

**Figure F.3:** MVA reduction steps diagrams

$$\left( \frac{1}{2561} + \frac{1}{968} \right) = 702 \text{ MVA} \quad (4.6)$$

$$\left( \frac{1}{702} + \frac{1}{333} + \frac{1}{563} \right) = 161 \text{ MVA} \quad (4.7)$$

$$\underline{\text{MVA Parallel} = \text{MVA1} + \text{MVA2}}$$

$$161 + 229 = 390 \text{ MVA} \quad (4.8)$$

$$3 \text{ phase fault current} = \frac{390}{(1.732 \times 11)} = 20.5 \text{ kA}$$

(4.9)

#### F.4 Single phase to earth fault

The above calculations were for three phase fault. The MVA method can be used to calculate single phase to earth fault, as illustrated in Figure. F.6. The positive sequence MVA will be the value calculated in the previous calculations and in the most applications, the positive sequence MVA will be the same as the negative MVA. The zero sequence MVA however, will usually be different from the positive MVA. For example in Figure F.3, only 16 MVA transformer will contribute to the earth fault at 11 kV through the neutral connected earth.

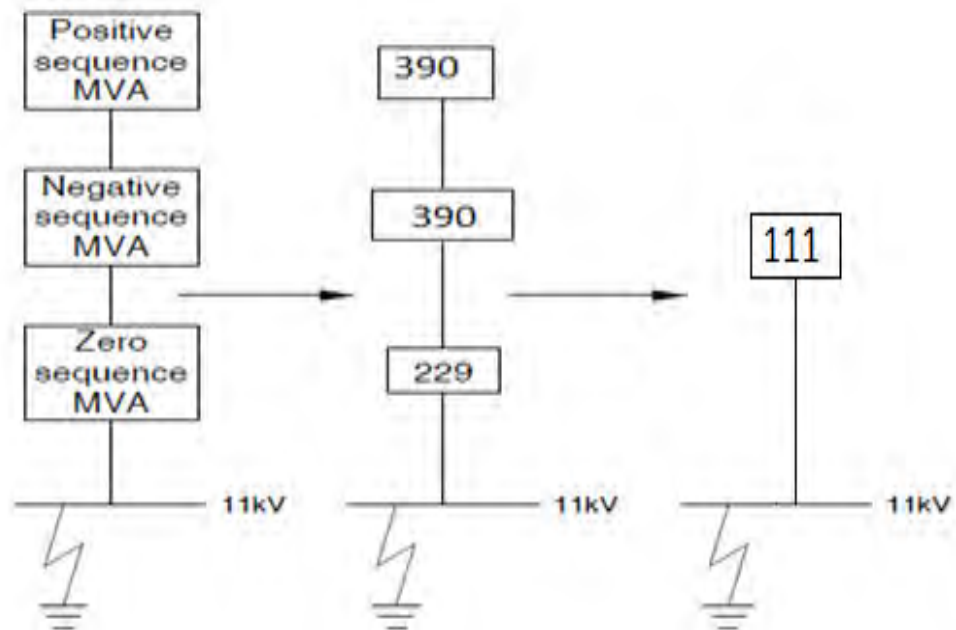

**Figure F.4:** MVA reduction diagram for single phase to earth fault.

Fault level MVA

$$\left( \frac{1}{390} + \frac{1}{390} + \frac{1}{229} \right) = 111 \text{ MVA} \quad (4.9)$$

Single phase to earth fault = 3 x 111 MVA

$$= 333 \text{ MVA}$$

$$\frac{333}{(1.732 \times 11)} = 17.5 \text{ kA at 11 kV}$$

### **F.5 Sequence MVA**

Positive sequence MVA = MVA1 = 390

Negative sequence MVA = MVA2 = 390 and

Zero sequence = MVA0 = 229

### **F.6 Advantages of the MVA method**

The advantages of the MVA method of calculating fault level are as follows:

- There is no need to convert impedance from one voltage to another, this is a requirement in the ohmic method.
- There is no need to select a common MVA base and then convert the data to the common MVA base, this is a requirement in per unit method. The formulas for conversion are complex and not easy to remember.
- Both ohmic method and per unit method usually end up with small decimals. It is more prone to make mistakes in the decimal with resulting errors several orders of magnitude from the correct value.
- The MVA method uses large whole numbers and this makes for easier manipulation and hence less prone to errors.

IMPROVING BUFFALO CITY'S SUB-TRANSMISSION RELIABILITY  
REFERENCES

**Dissertation Submission**

After consultation with the supervisor a candidate hoping to graduate in June / December is required to submit via PeopleSoft to the Faculty Office:

- Dissertation
- Please include the following in your dissertation upon submission:
- The following signed declaration: "I know the meaning of plagiarism and declare that all the work in the document, save for that which is properly acknowledged, is my own. This thesis/dissertation has been submitted to the Turnitin module (or equivalent similarity and originality checking software) and I confirm that my supervisor has seen my report and any concerns revealed by such have been resolved with my supervisor."; and
- a copy of your completed and signed EBE Faculty 'Assessment of Ethics in Research Projects form'. This would have been completed when you registered for your dissertation.

Signed

02/08/2016