

Carstens Rd Townhouse

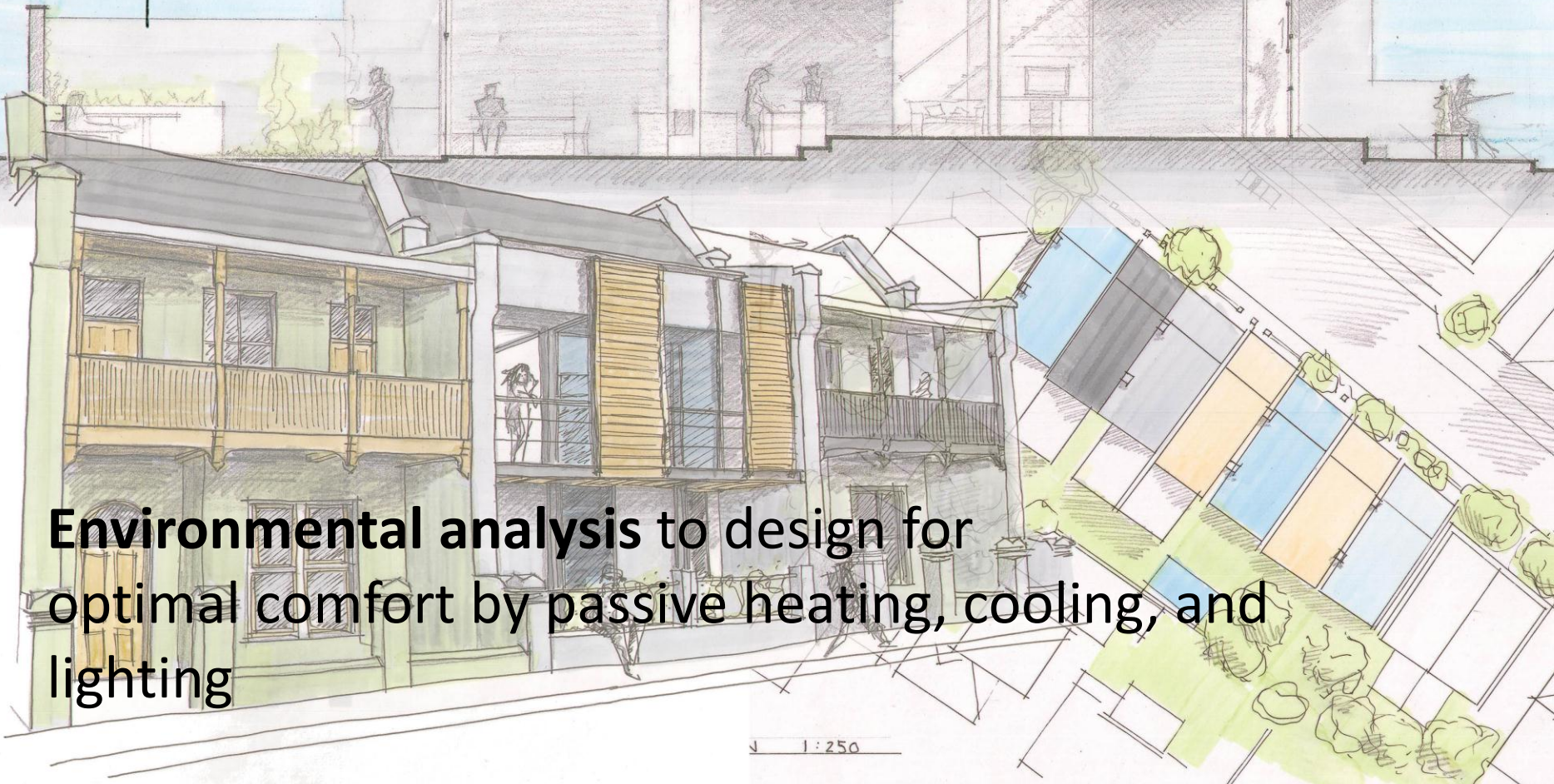

Environmental analysis to design for optimal comfort by passive heating, cooling, and lighting

Site Plan

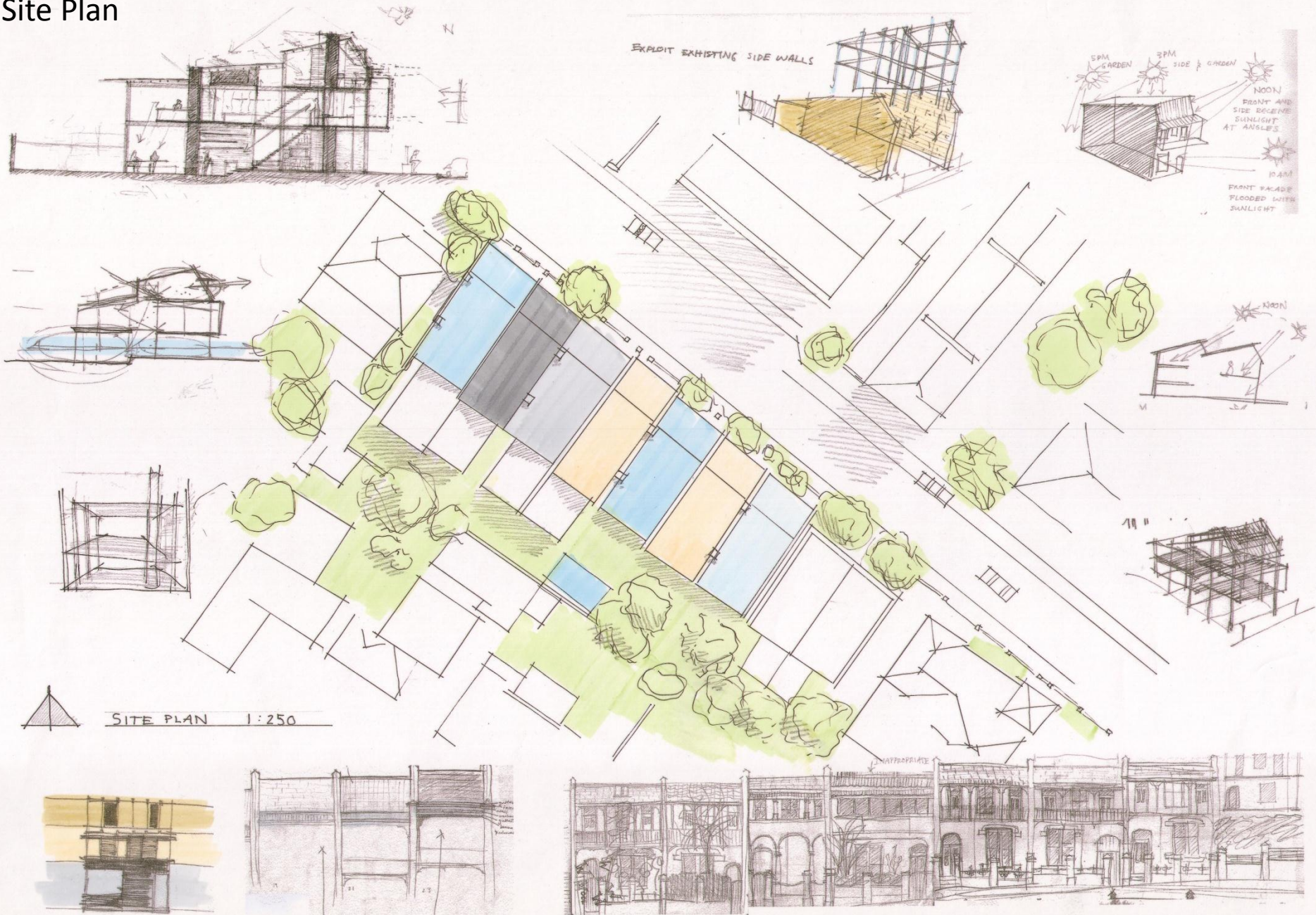

SITE PLAN 1:250

FRAMEWORK HOUSE

C. MORONELL

Site Analysis (Opportunities, Problems and Design Cues)

Site analysis (opportunities, threats and design cues)

Natural Factors

Solar analysis (according to season and time of day)

Temperature (according to season and time of day)

Humidity (according to season and time of day)

Precipitation (according to season)

Wind direction and strength (according to season and time of day)

Vegetation (trees, shrubs, grasses etc)

Urban and other factors

Location

Site boundaries and area (including on site features and the surroundings)

Site sections (at least one cross and one transverse)

Urban character

Vehicular: easy access and egress points, parking, public transport

Pedestrian flows

Quiet? Noise sources (different times of the day)

Good views (nearby, distant, eye level, higher up etc). Bad views too. Views onto the site

Site Plan

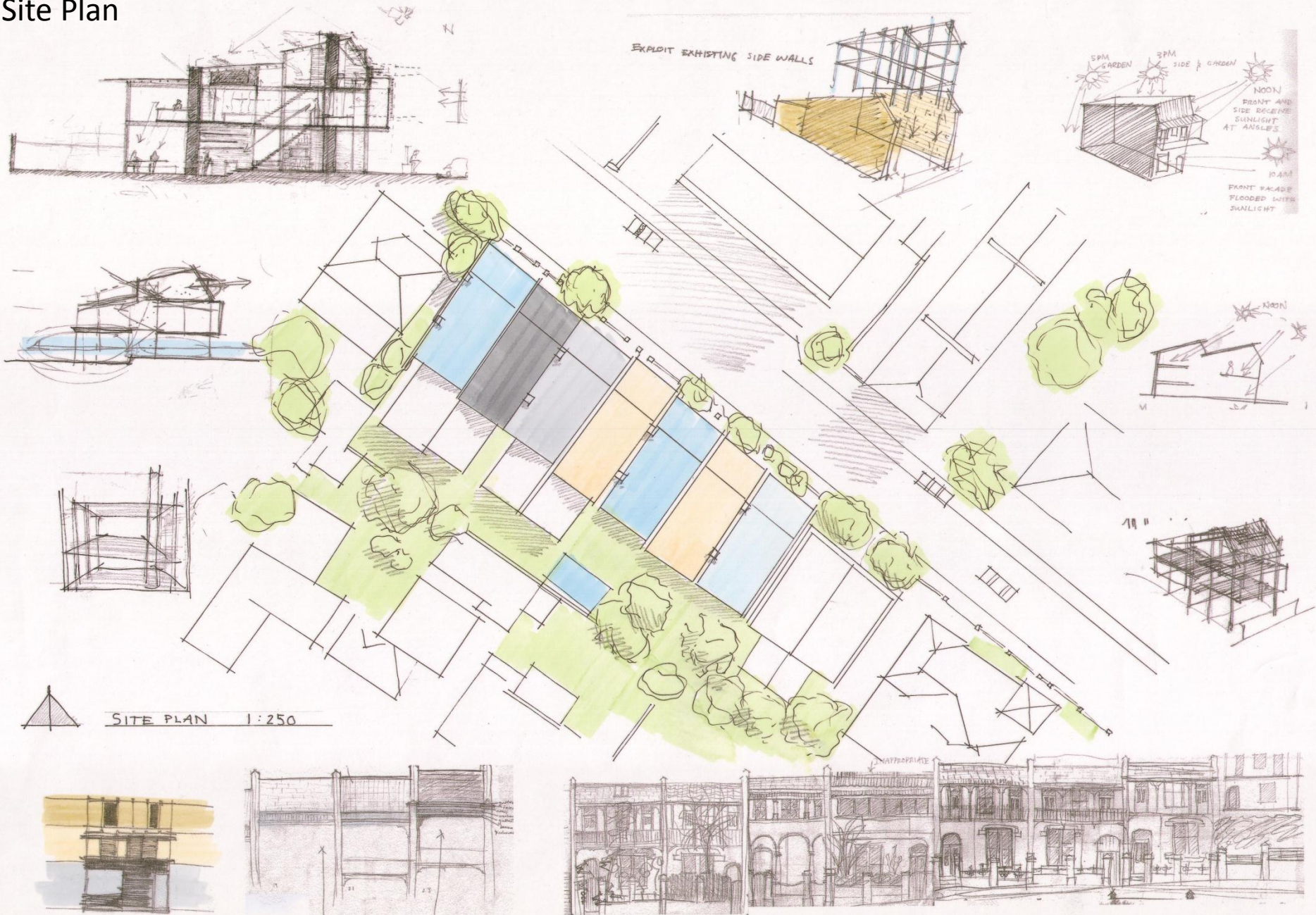

FRAMEWORK HOUSE

C. MORONELL

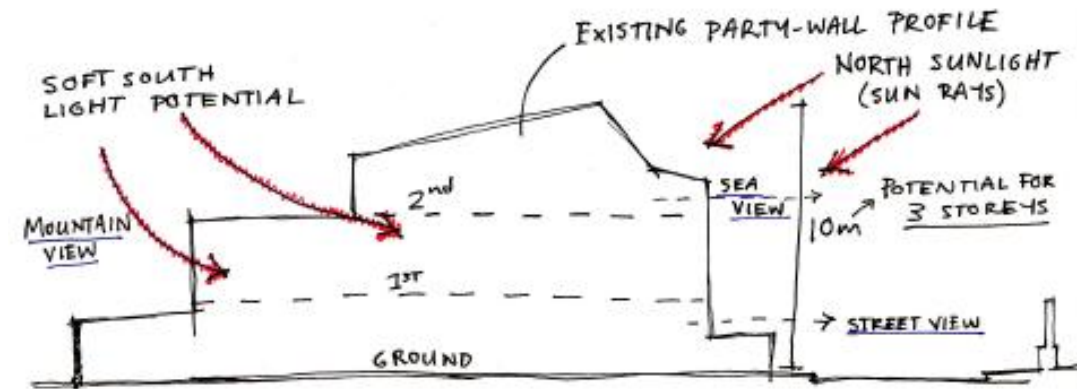
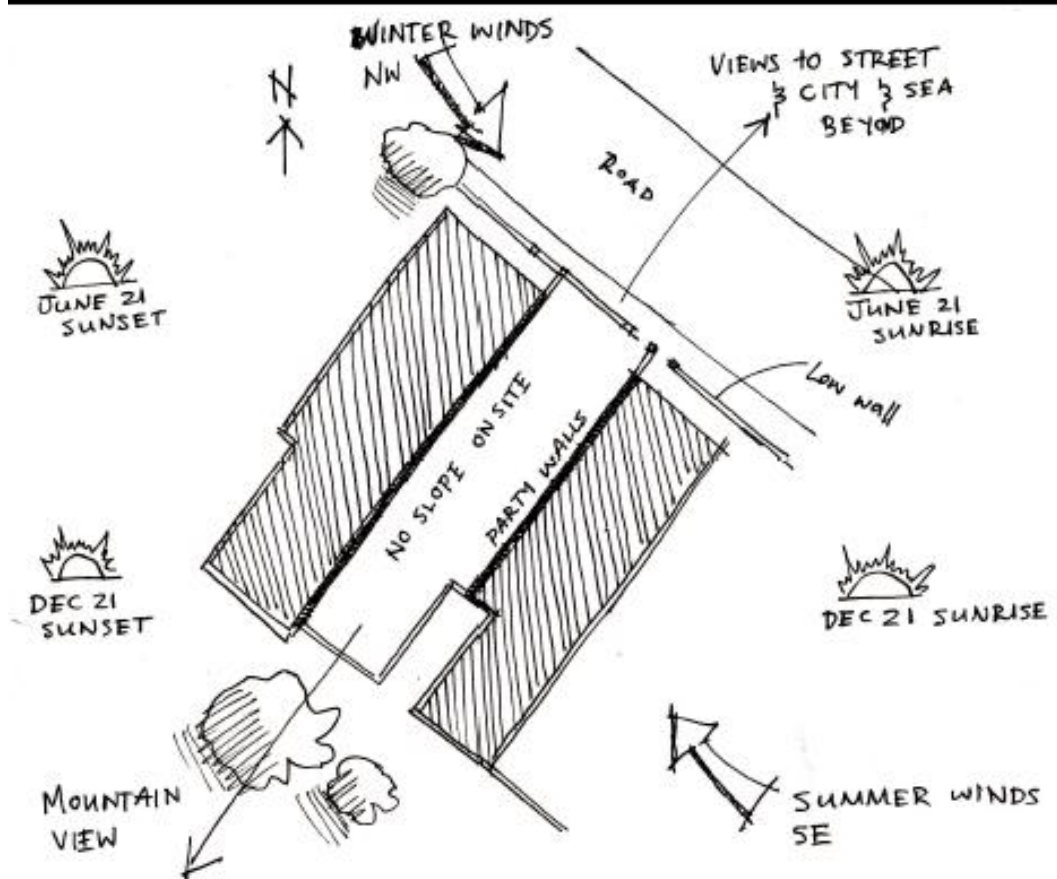

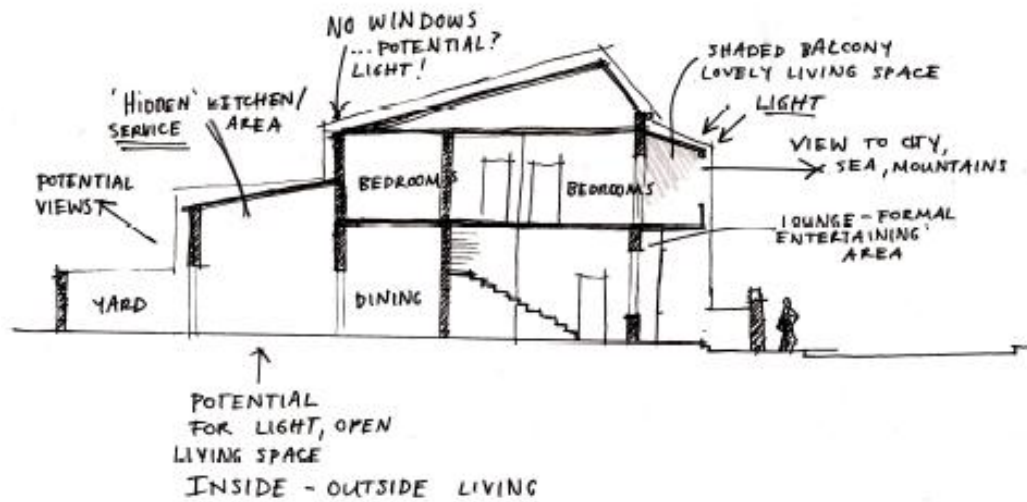
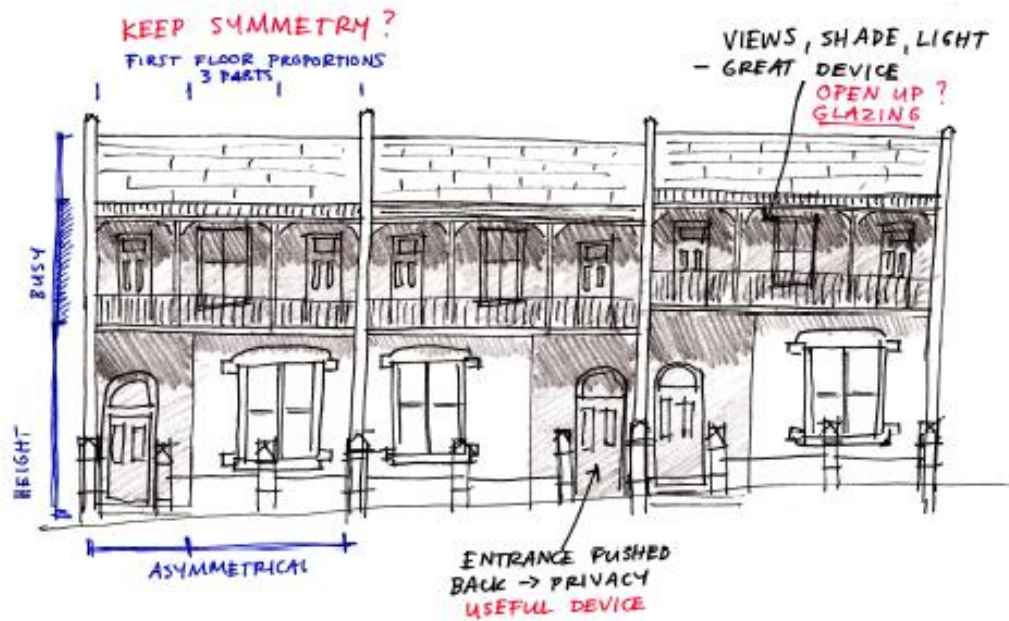

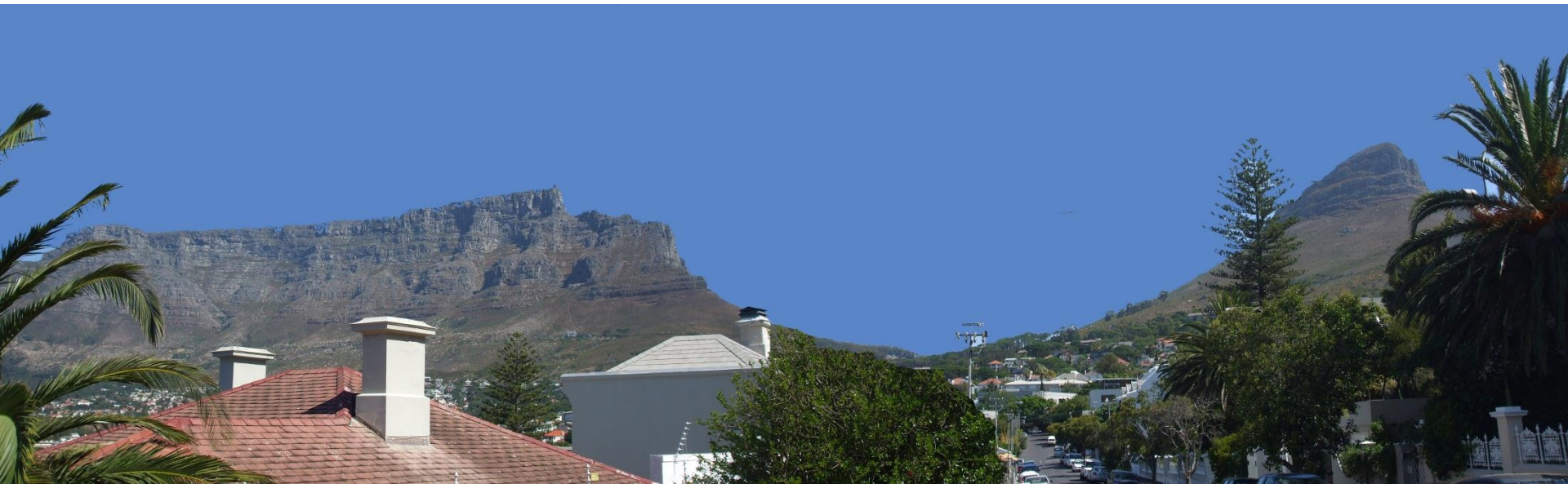

View to the back



Front view: street level view



Front view: balcony level view

Daylighting

- **Daylighting** – Using natural light to illuminate interiors, minimising the need for artificial lighting
- The site receives no light from its length, being a rowhouse divided by tall solid brick walls
 - Therefore the front and back facades need to be very **transparent** to illuminate the length of the house (**Design choice 1: glazed facades**)

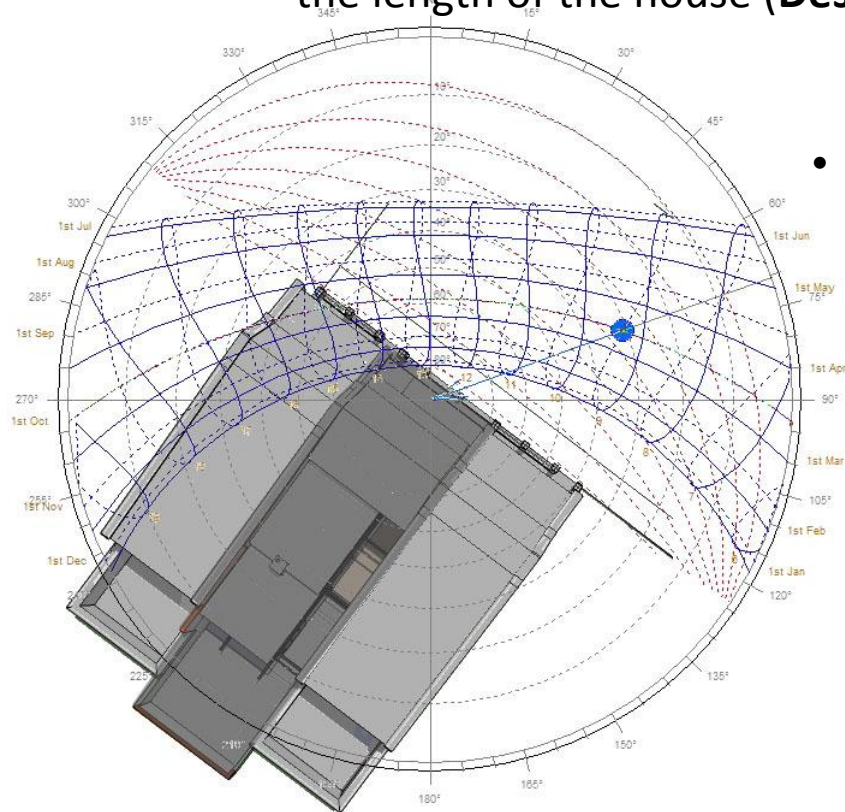

- At a glance, the orientation of the house (NE facing) shows that the front facade will receive direct sunlight, while the back garden facade will almost always be shaded from direct sunlight.

(Design choice 2: shade front facade for solar control, allowing back to be unshaded)

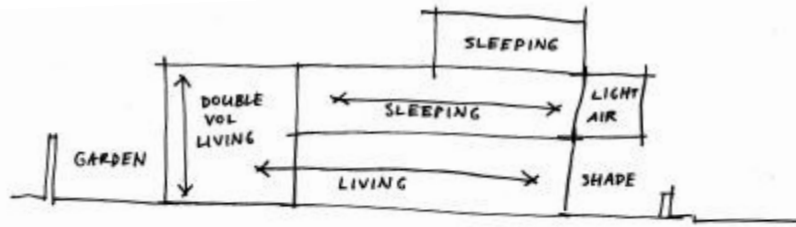

OPEN SPACES MORE:

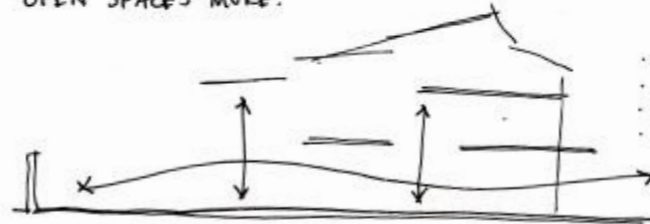

- CHANGES IN HEIGHT
- VARIED LIGHT QUALITIES
- CONNECTION BTWN FLOORS
- OPEN GROUND FLOOR

SPATIAL ORGANISATION

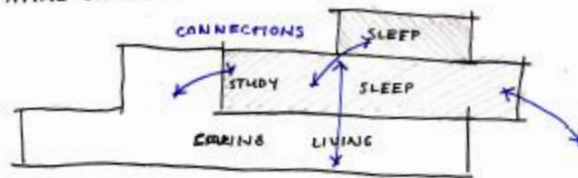

CONSTRAINTS:

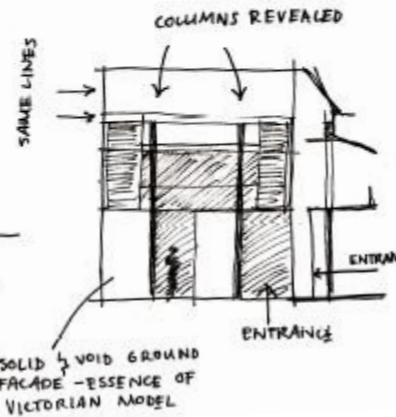
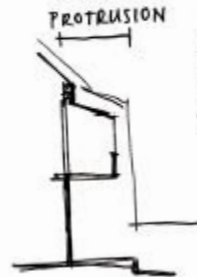
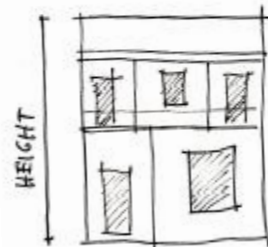

SOLID WALL ENVELOPE

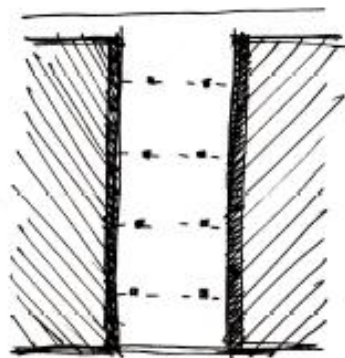

STEEL FRAME

↓
SELF-SUPPORTING SYSTEM

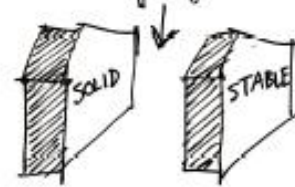

Light timber
FLOORING EASILY
INSERTED

- STEEL STRUCTURE
- = NO SOLID WALLS NEEDED
- = FREE FACADES
- = TRANSPARENCY
- = LIGHT & AIRY

} GLASS
LIGHT
AIR

VENTILATION
DIAGRAM

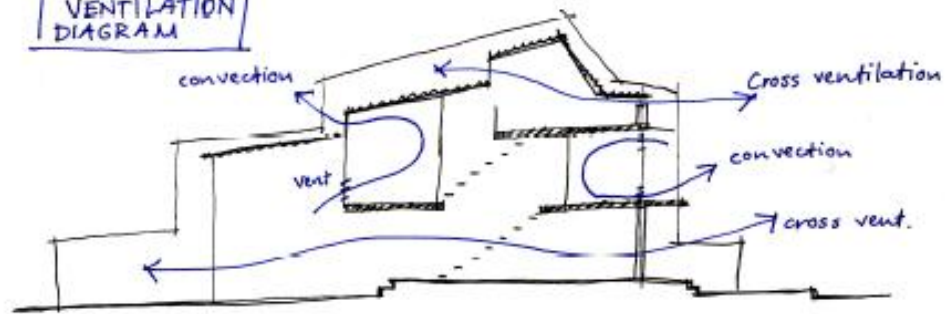

Street facade



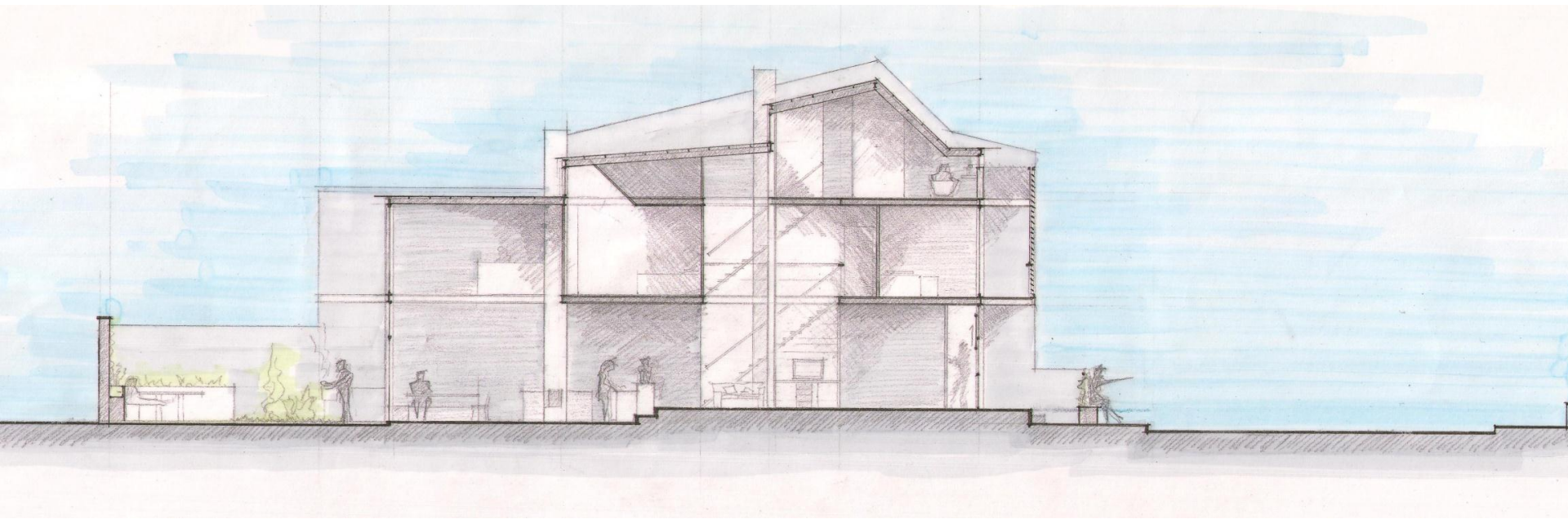

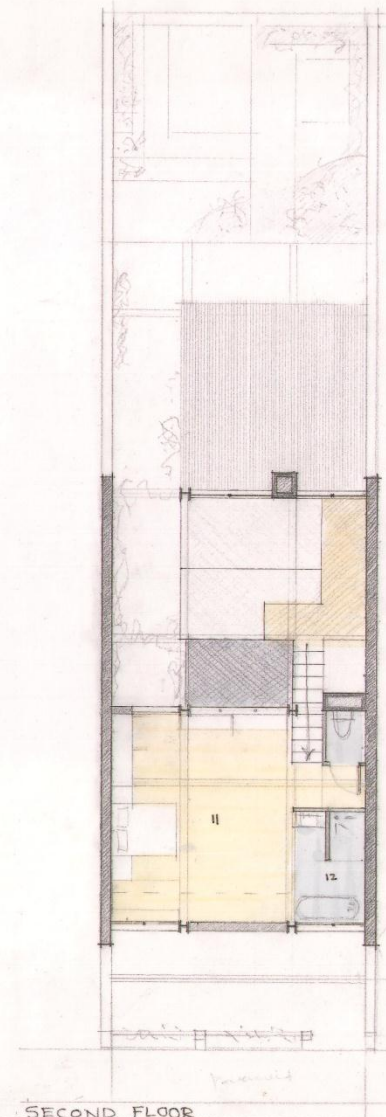
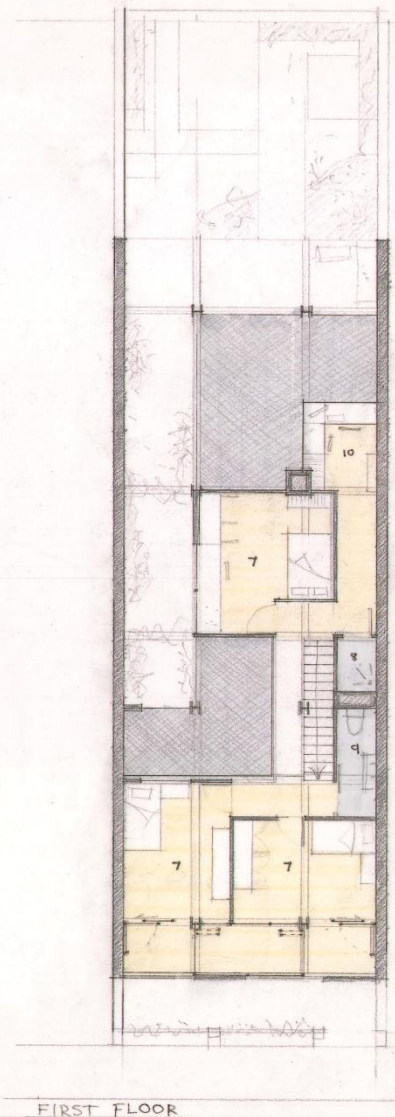
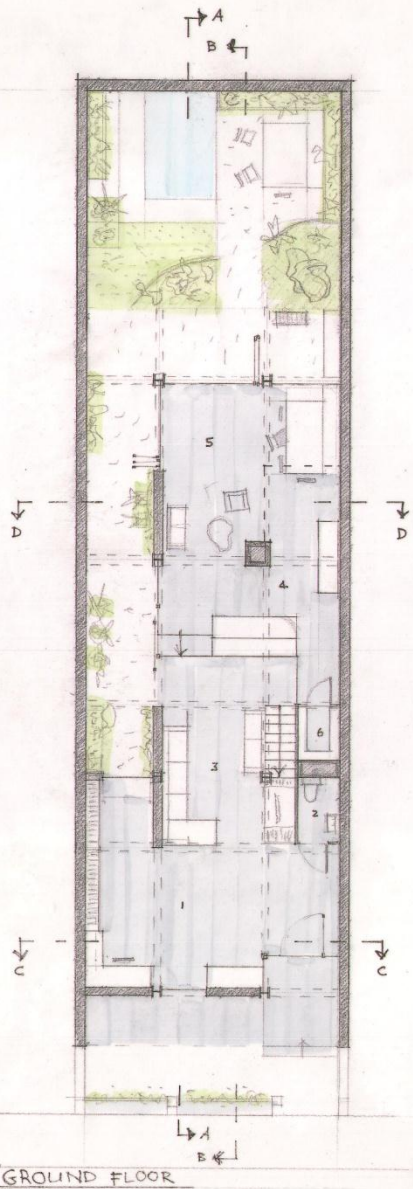

- | | | |
|--------------------|--------------------|------------------|
| 1. STUDY / LIBRARY | 5. DINING / LIVING | 9. KID'S WC |
| 2. GUEST WC | 6. PANTRY | 10. KID'S STUDY |
| 3. TV LOUNGE | 7. KID'S BEDROOM | 11. MAIN BEDROOM |
| 4. COOKING | 8. SHOWER | 12. OPEN BATHING |

FRAMEWORK HOUSE

C. MORONELL

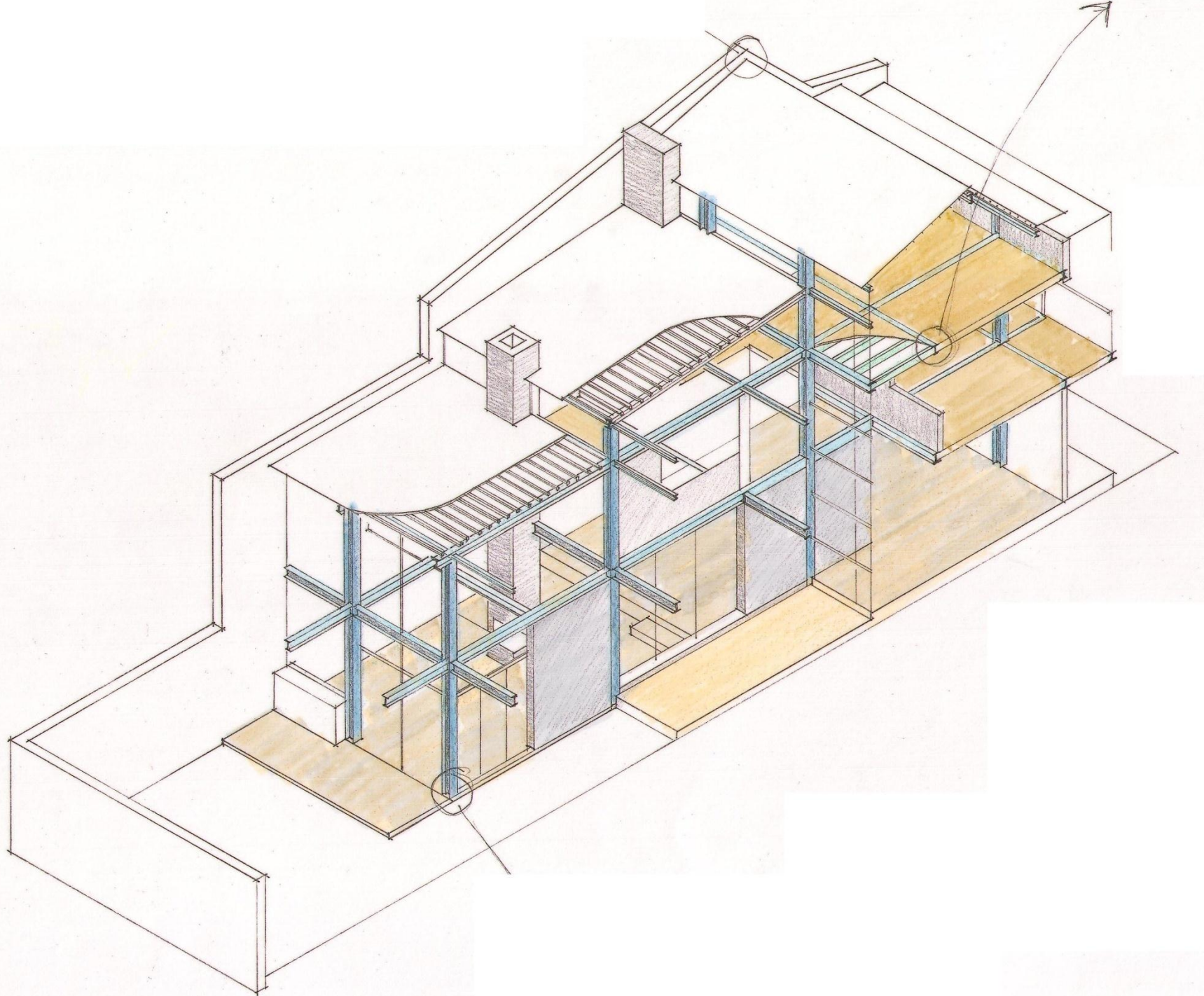

Daylighting

- **Daylighting** – Using natural light to illuminate interiors, minimising the need for artificial lighting
- The site receives no light from its length, being a rowhouse divided by tall solid brick walls
 - Therefore the front and back facades need to be very **transparent** to illuminate the length of the house (**Design choice 1: glazed facades**)

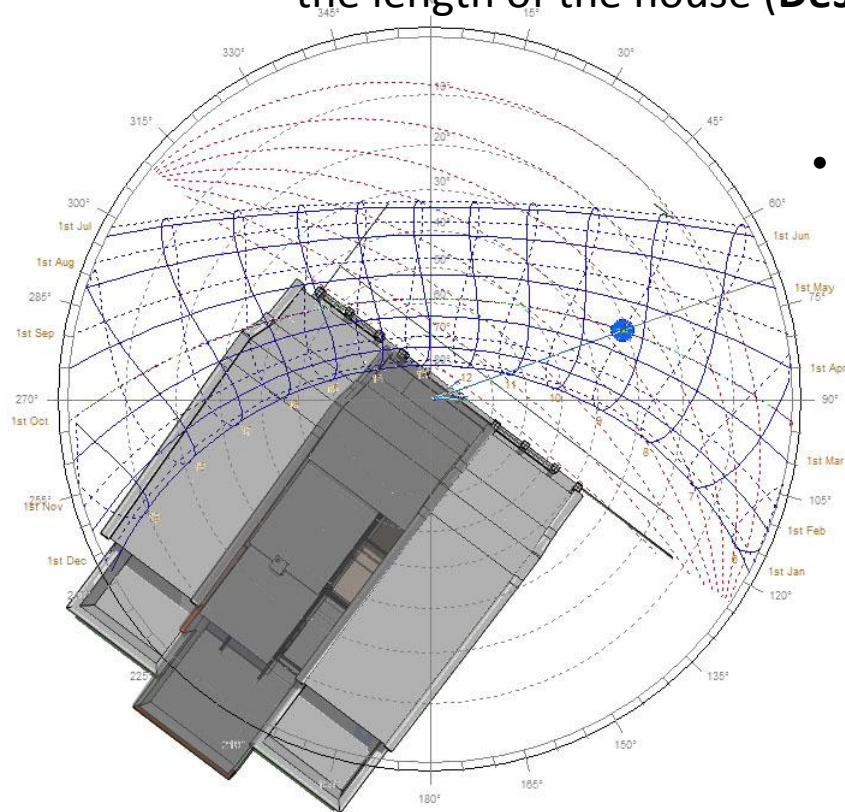

- At a glance, the orientation of the house (NE facing) shows that the front facade will receive direct sunlight, while the back garden facade will almost always be shaded from direct sunlight.

(Design choice 2: shade front facade for solar control, allowing back to be unshaded)

Back facade

- Diffuse south light illuminates ground floor double volume living area
- View to mountain

Front facade

- Solid wall and glazing gives light to study and entrance hall
- View to street

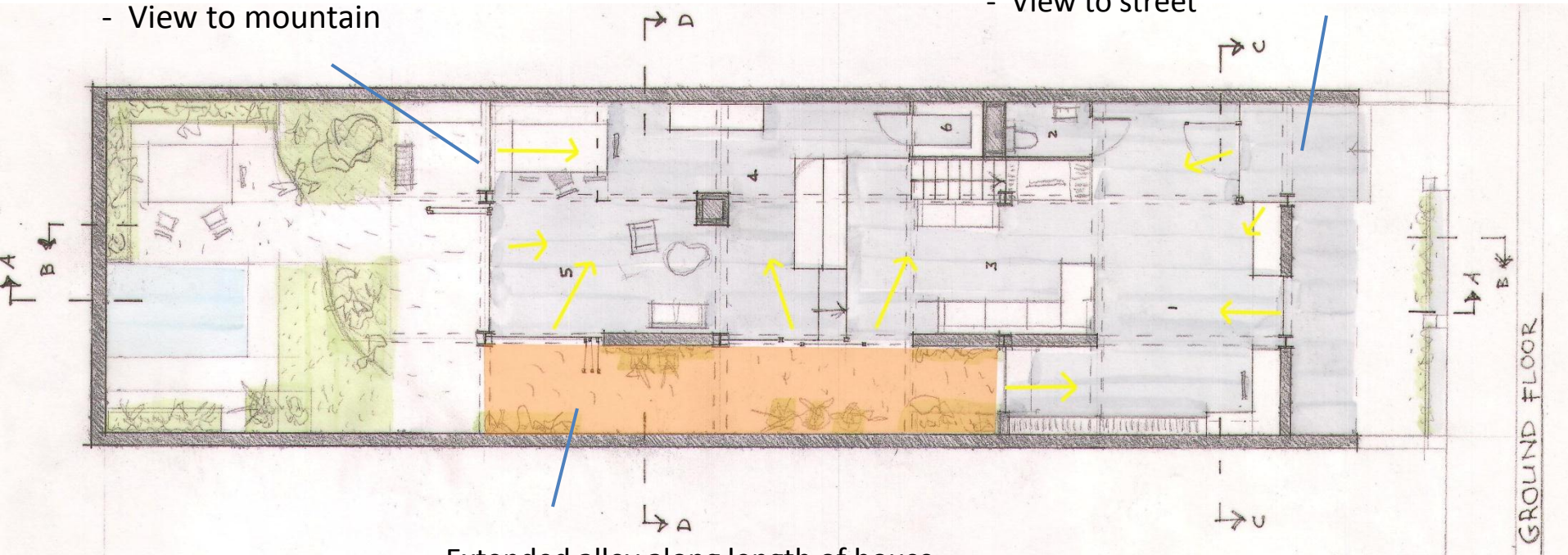

Extended alley along length of house

- diffuse light for study, staircase and kitchen areas
- Reflection off white side wall gives brighter light

Back yard glazed facade

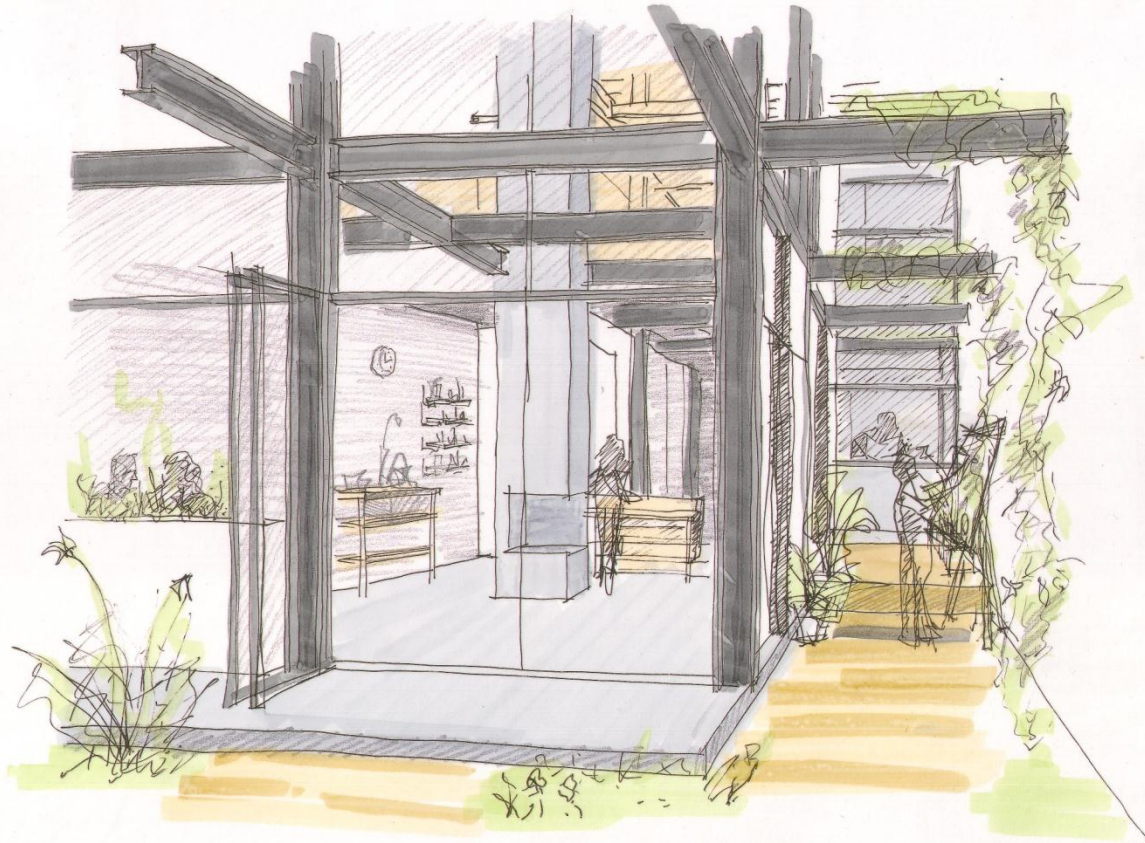

Design choice 4 - Stepped roof with strip windows

- Provide south light for bedrooms on upper floors
- Provide good mountain views from bedrooms

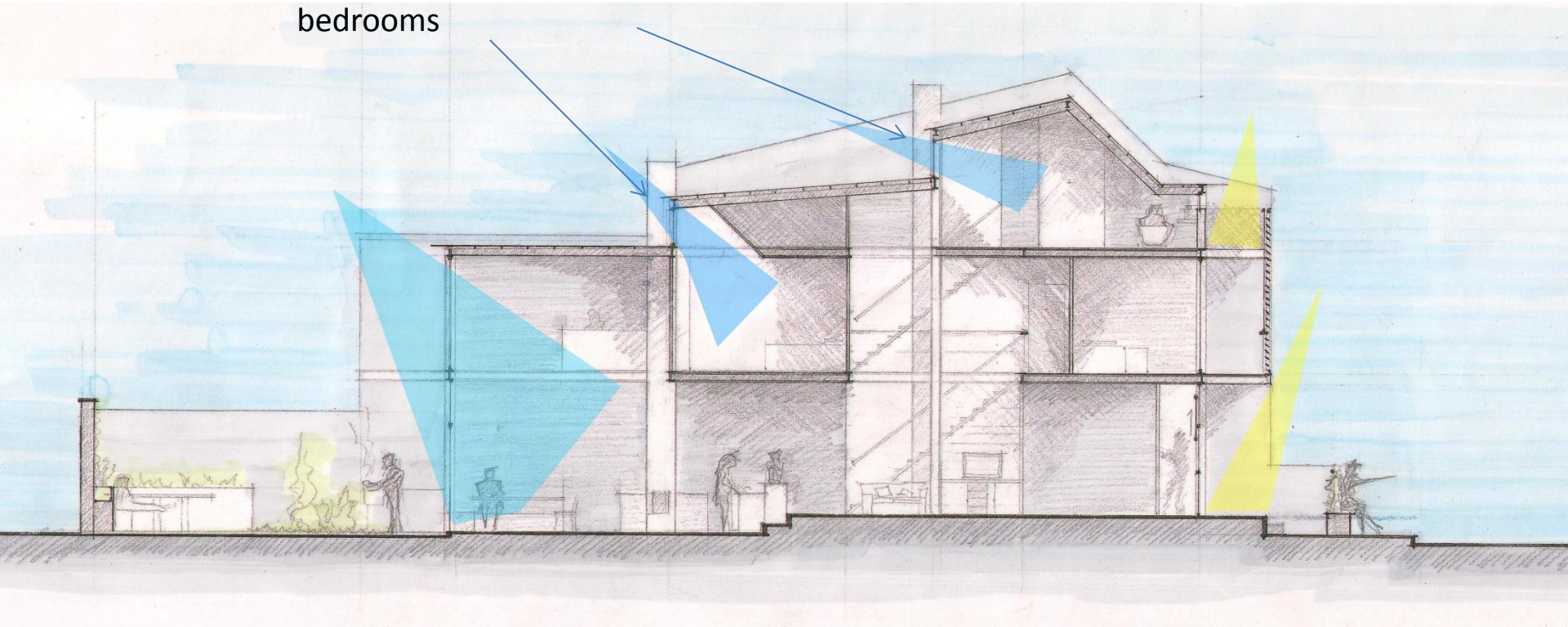

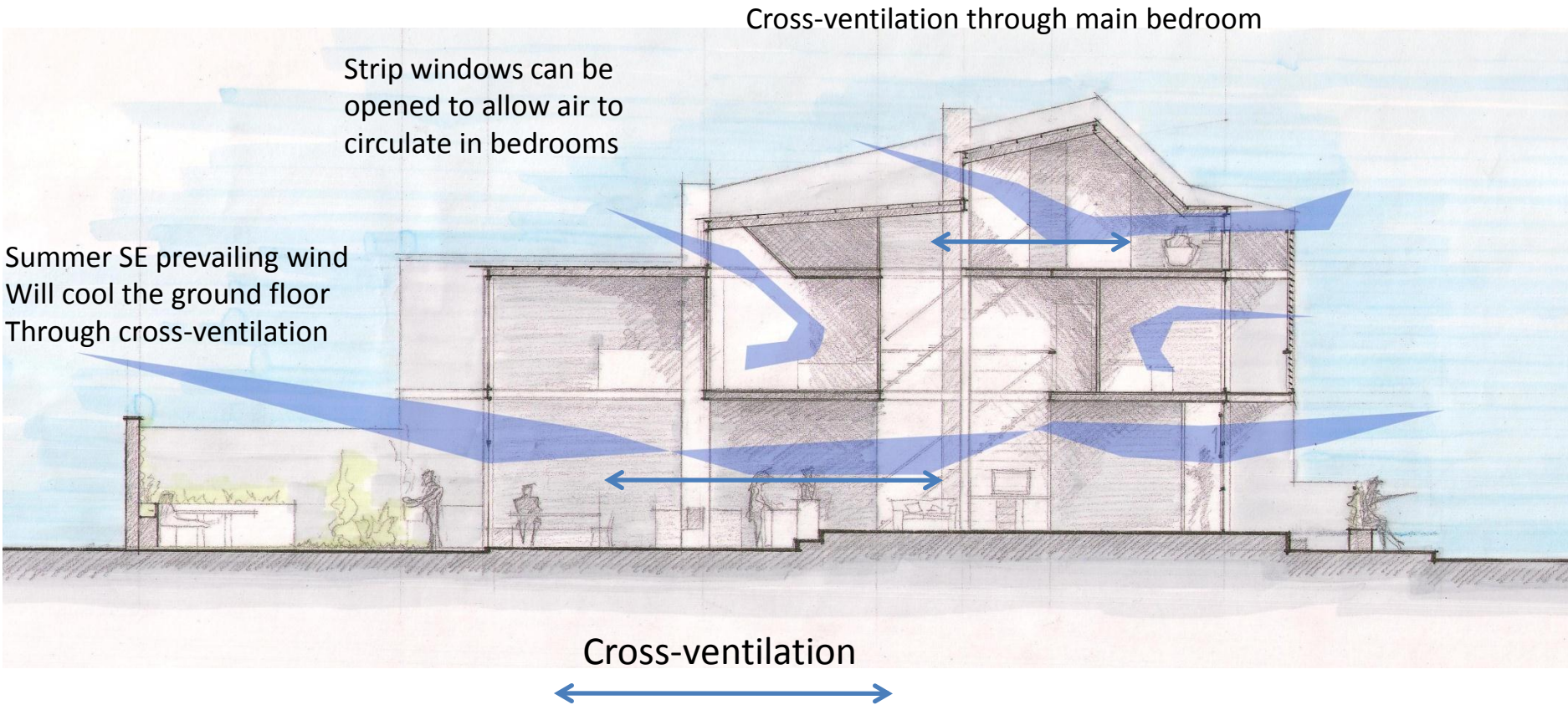

Shading

- **Shading** – **Minimising** heat gains from direct solar radiation in summer
 - **Maximising** heat gains in winter
 - Using design devices to optimise this
 - » Eg. Trombe wall (sun space) to max. Heat gains in winter
 - » Solar hot water system on roof – Piped down to ground floor slab (in winter), where the concrete absorbs heat throughout the day, stores it and slowly re-radiates it.
the LAG effect

SHADING DESIGN

Stereographic Diagram

Location: $-34.0^\circ, 18.6^\circ$
Sun Position: $66.4^\circ, 23.8^\circ$
HSA: 29.4°
VSA: 26.8°

- Use a sun path diagram

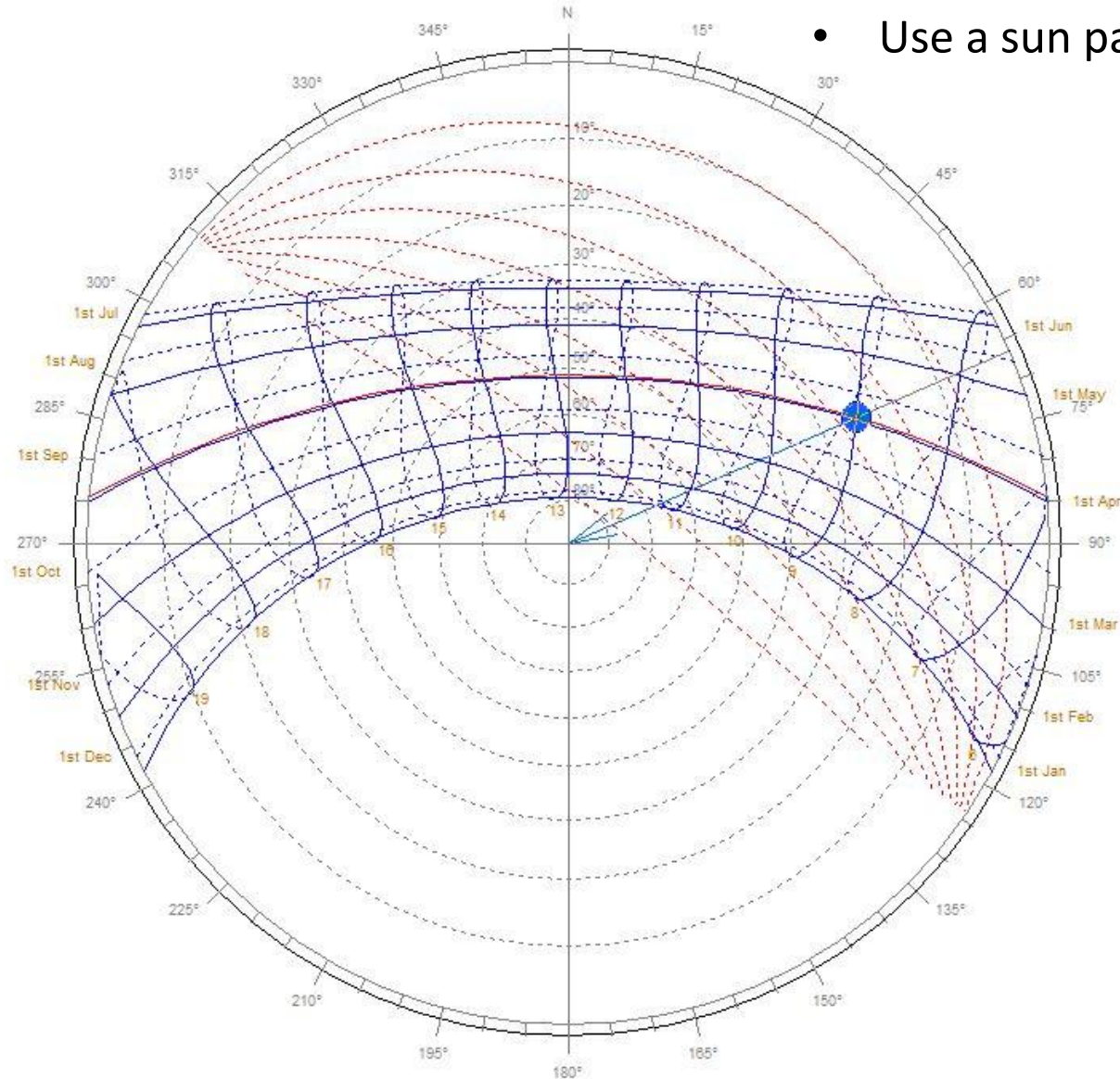

Time: 09:00
Date: 2nd Apr (92)
Dotted lines: July-December.

- Choose a period to design shading for:
 - In Cape Town, the hottest months fall between the equinoxes 22 Sep – 22 March, therefore I chose to design for shading from **1 Oct to 1 April**, to make life easier.
- The time of day is important
 - Before 9am and after 4pm, the heat from direct sunlight is minimal
 - Therefore my daily time period to shade is **9h00-16h00**

1 Oct	9h00	HSA = 33 °	VSA = 36 °
	14h00	HSA = -74 °	VSA = 78 °
1 April	9h00	HSA = 29 °	<u>VSA = 27 °</u>
	14h00	HSA = -82 °	VSA = 81 °

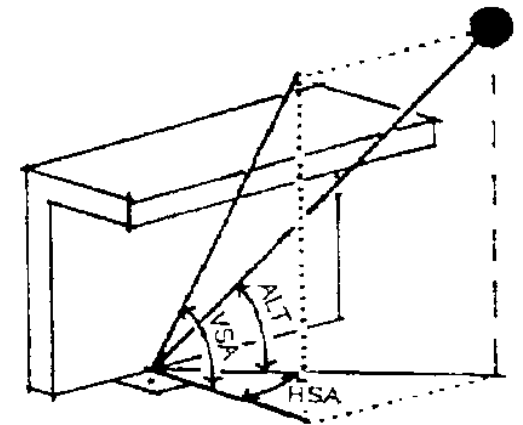

3.2 The shadow angle protractor

This is a semi-circular protractor, showing two sets of lines (Fig.33):

- radial lines, marked 0 at the centre, to -90° to the left and $+90^\circ$ to the right, to give readings of the HSA
- arcual lines, which coincide with the altitude circles along the centreline, but then deviate and converge at the two corners of the protractor; these will give readings of the VSA.

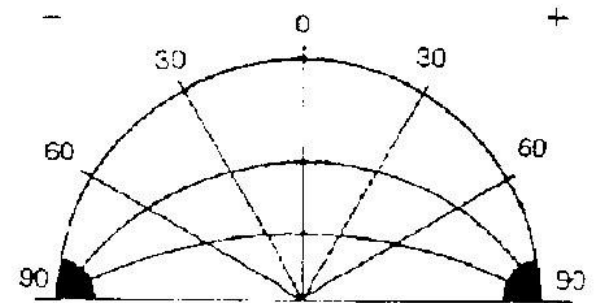
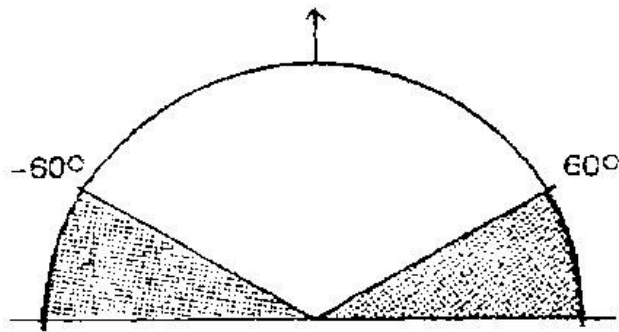
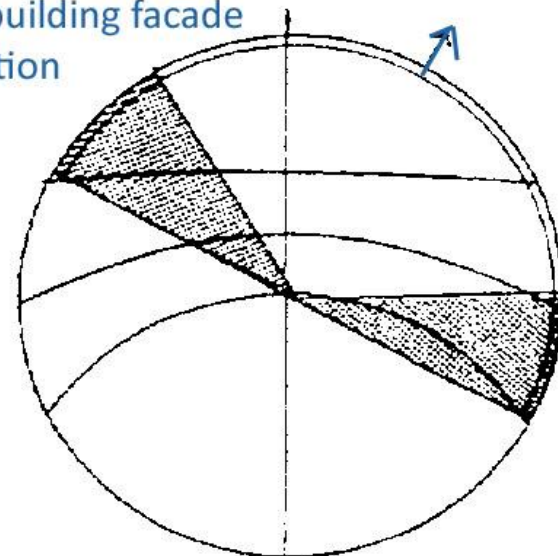

Fig.33 The shadow angle protractor

Orientation of building facade under investigation



Shading mask of HSA of 60 and -60



Superimposed on sunpath diagram

Carstens Rd House
Orientated 37°
off North on sunpath
diagram

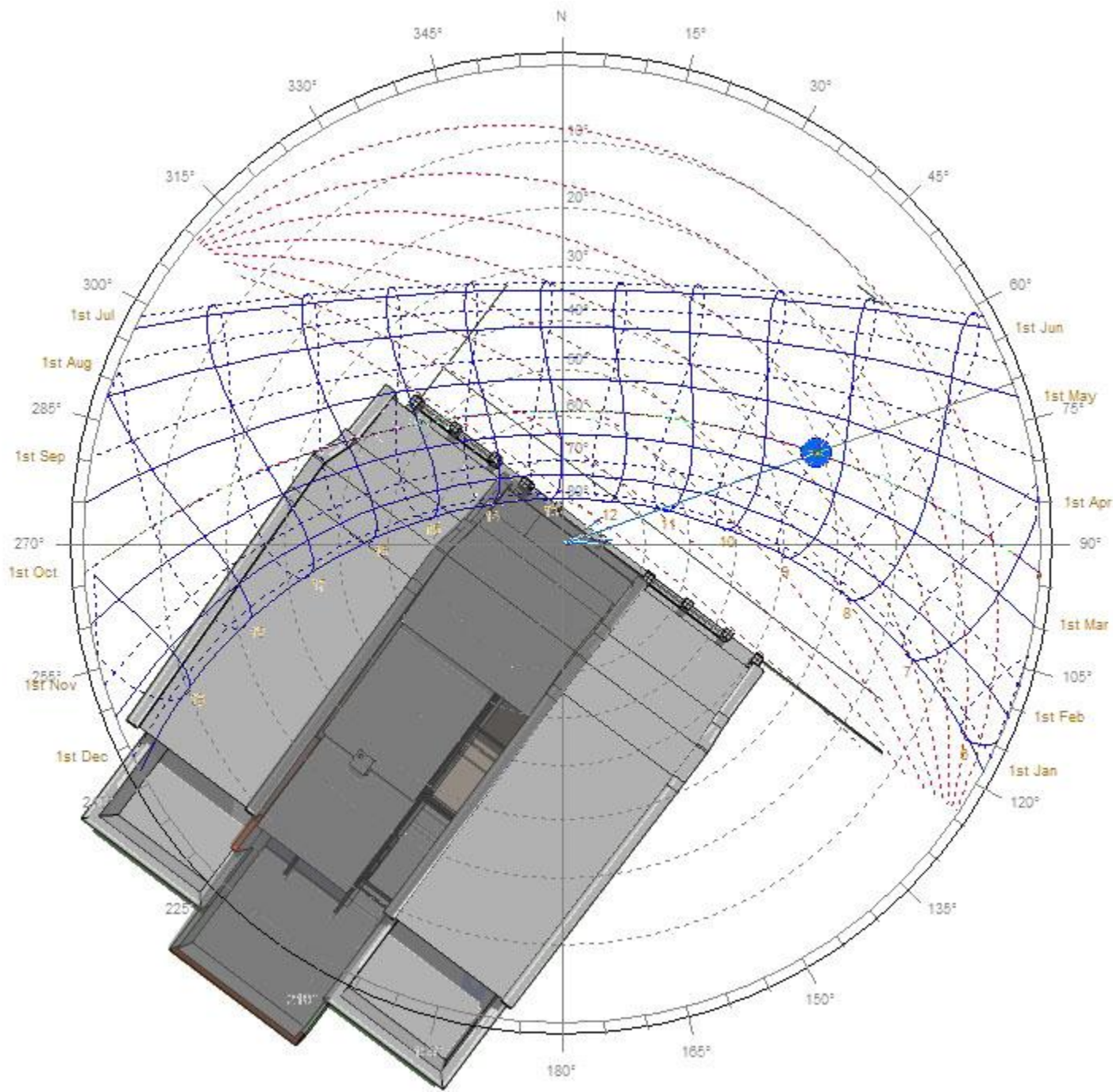

A useful environmental analysis tool is **ECOTECT Analysis**

- It generates solar path diagrams, gives you the VSA and HSA for specific times for the year, calculates thermal comfort and wind frequency graphs

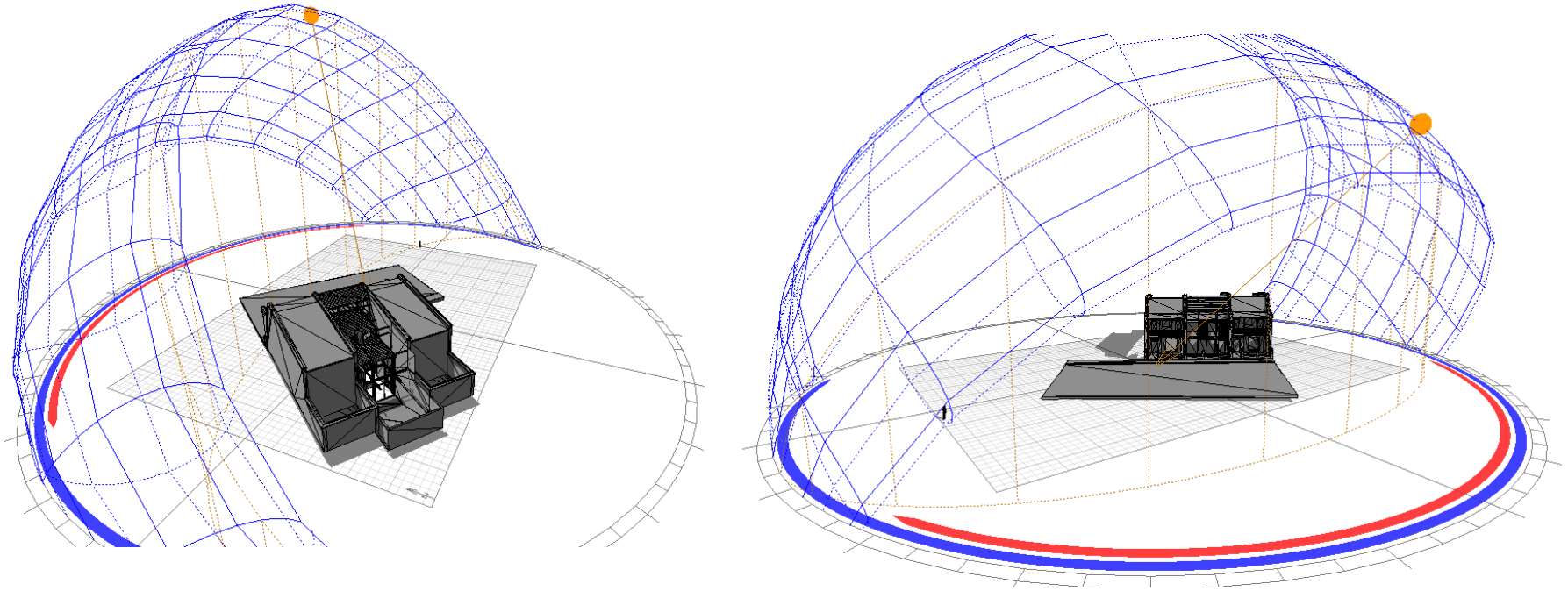

Import a sketchup model and weather data files for Cape Town to generate this model

The months for which shading must be designed

1 Oct – 1 April

Shaded on sun diagram

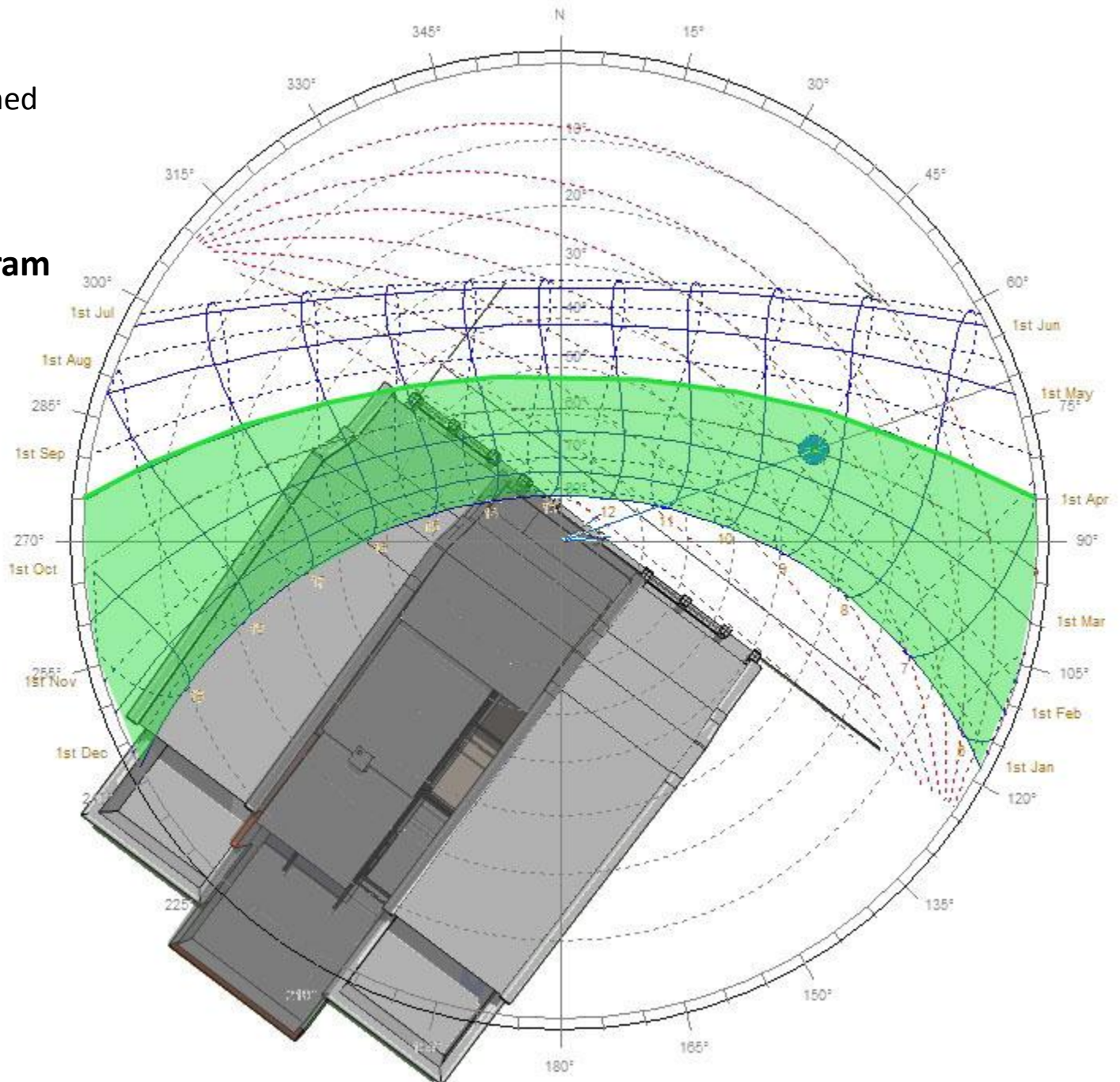

Use HSA to find the times of Day when VSA applies ie. When the facade is exposed to unwanted solar radiation

Use the max. HSAs on each side of north (max. from North 0°)

Use:
Oct 1 09h00 : 33°
April 1 14h00 : -82°

Shade these HSAs on the shadow angle protractor

Shaded area are outside of the factors under investigation (months, time, sun strength)

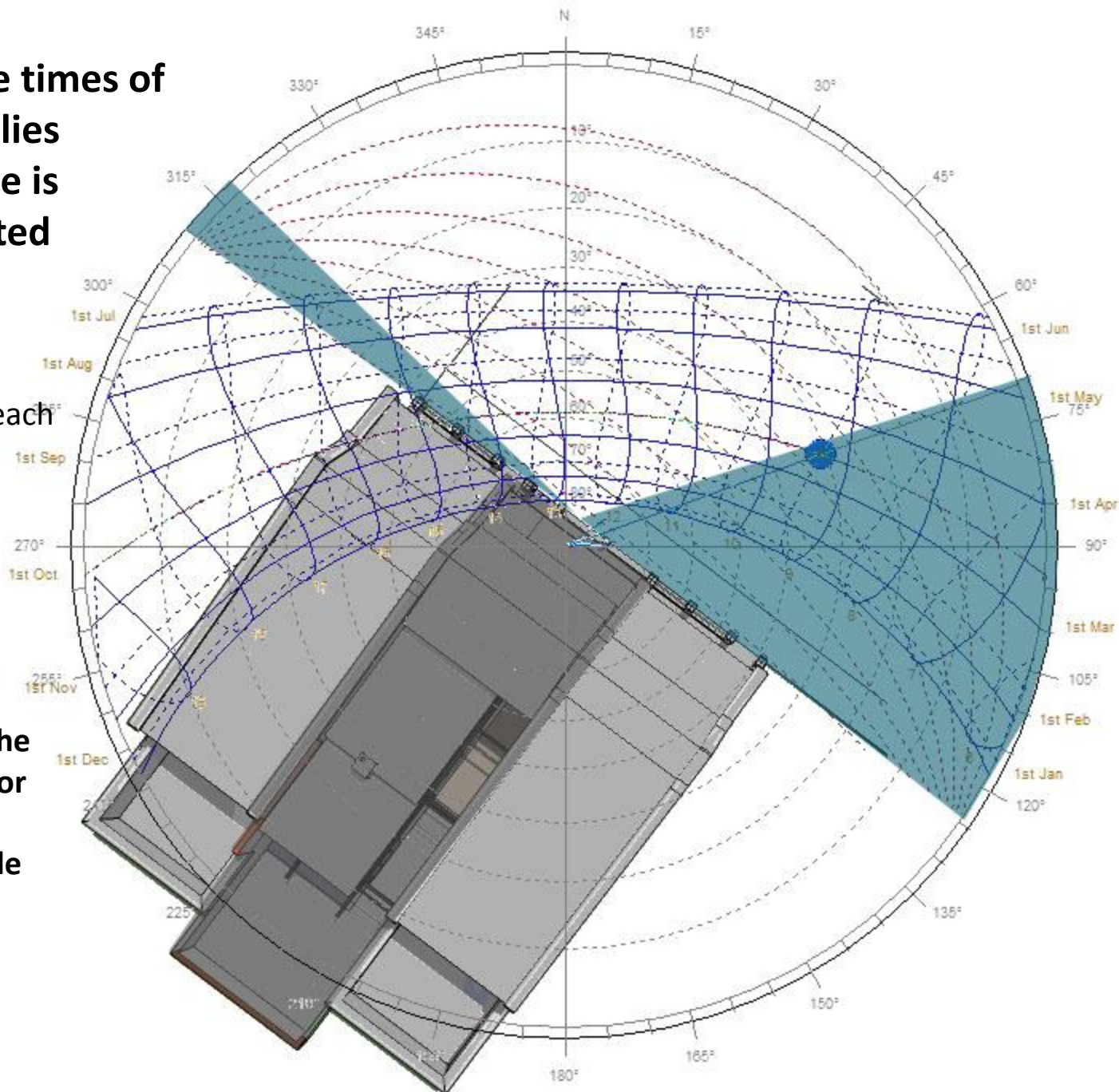

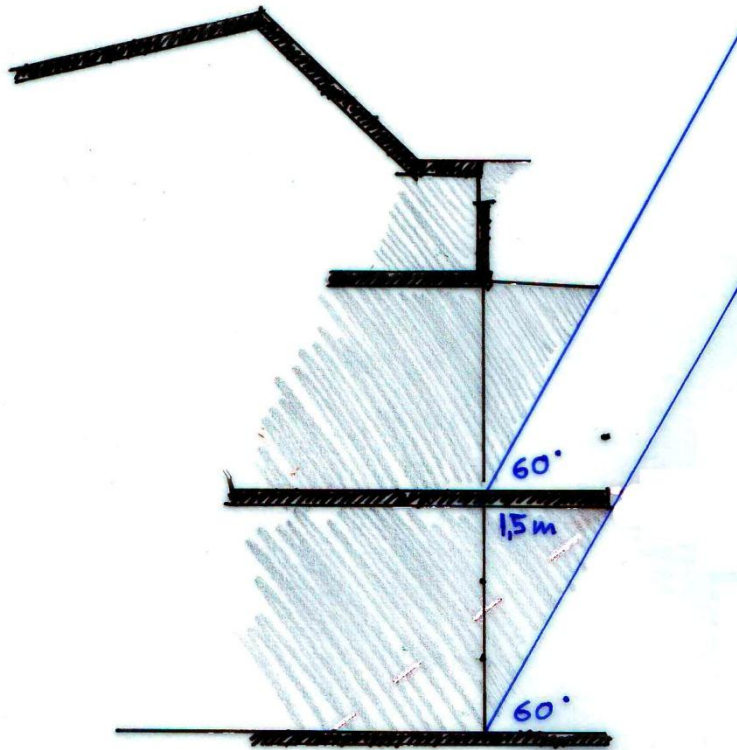

Calculate the VSA of the canopy and deck shading, by drawing a line from the bottom of the window to the extent of the canopy

The angle of the line is the VSA

Now **test** that this shading is sufficient:

The VSA of the shading canopies on ground
And first floors is 60°

Shade the shadow angle protractor to 60°

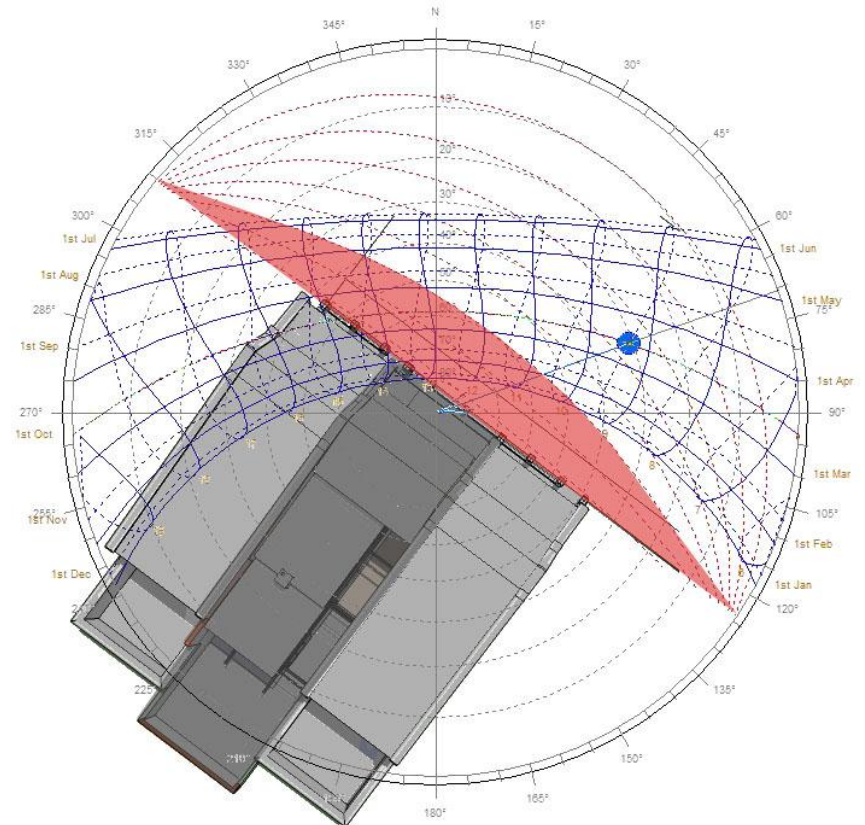

Overlay the HSA, VSA and months shading

The light green area is uncovered by the VSA and HSA, and the facade is therefore exposed to direct sunlight during certain times in the months highlighted

Is this 'danger zone' a concern in this case? Check..

Exposed:

Oct from 10am-12am

March from 10am-11am

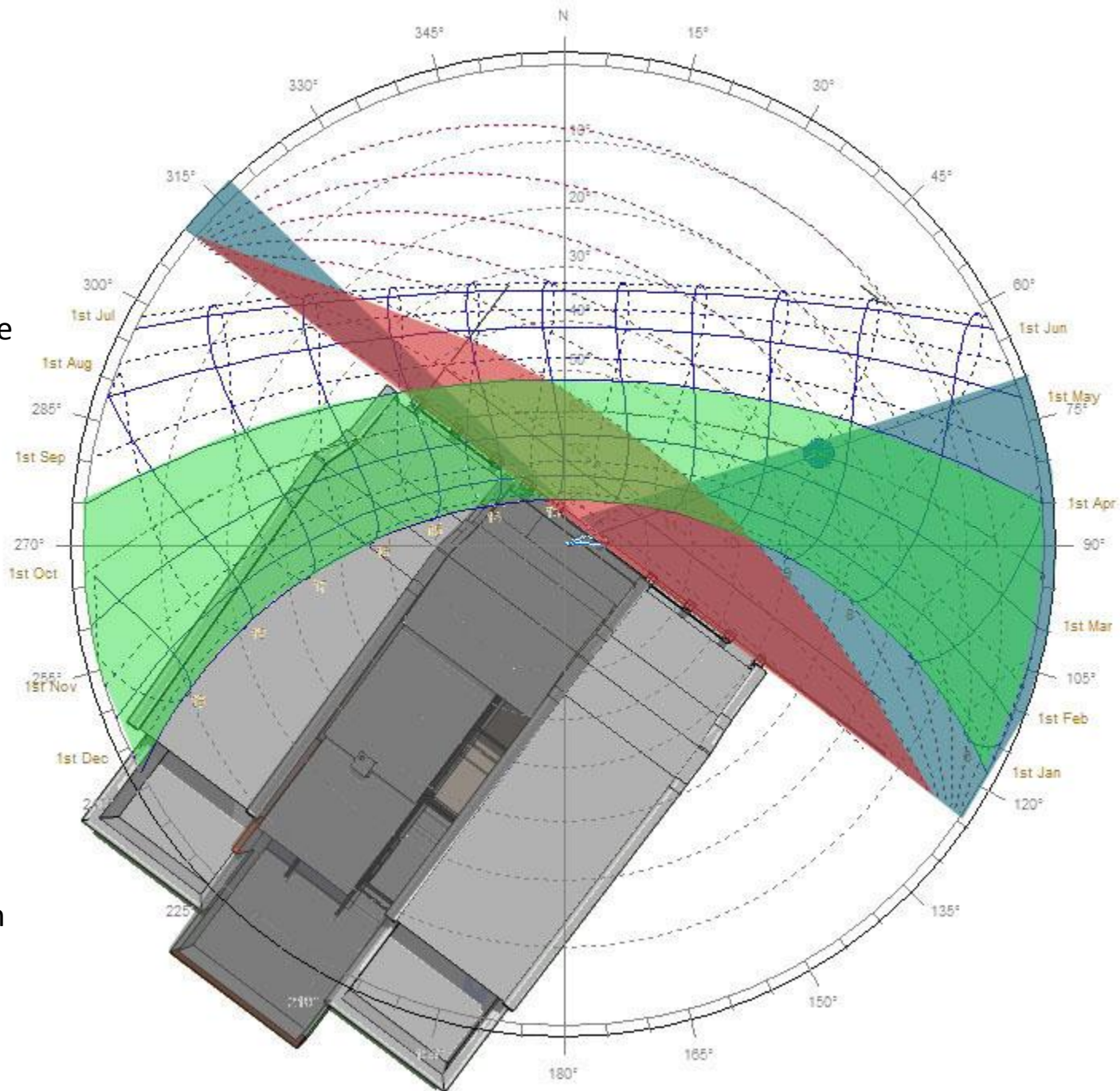

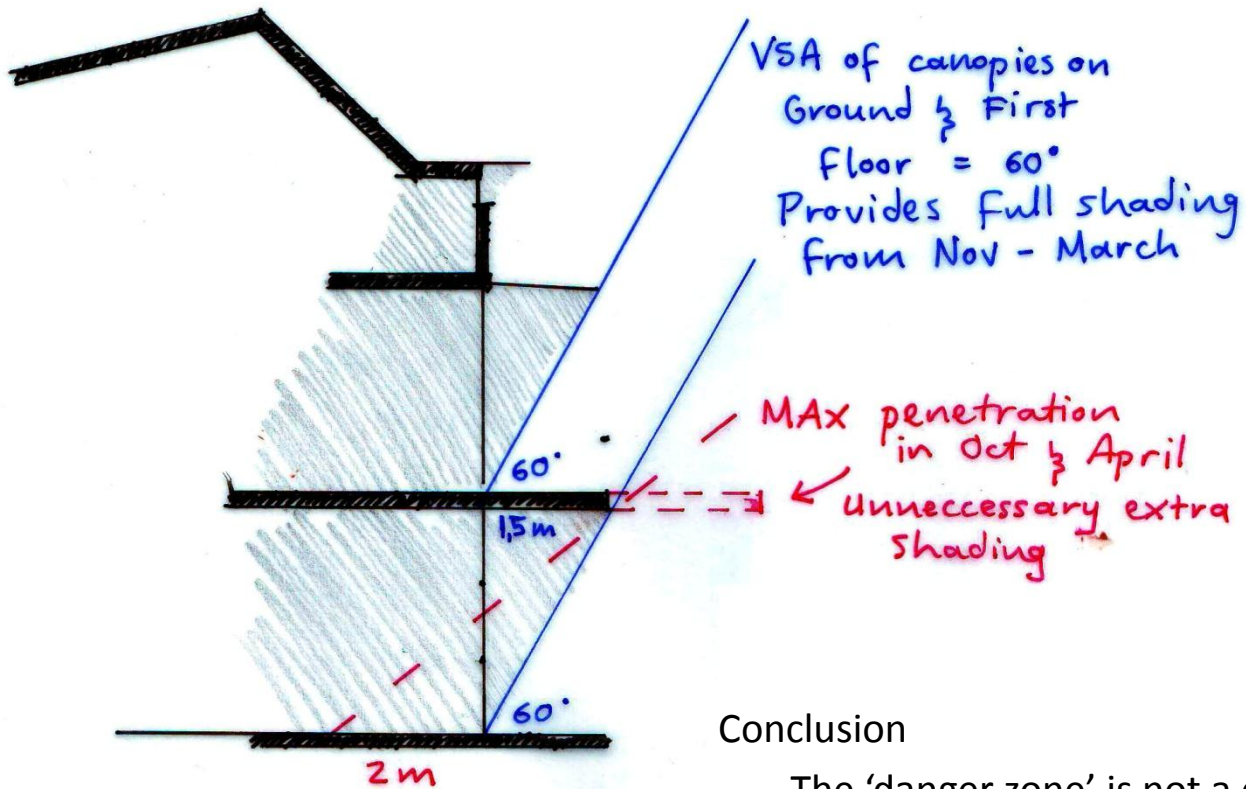

Conclusion

- The 'danger zone' is not a concern, as October and March are not the hottest summer months and the penetration of the sun rays for max. 2 hours a day is only 2m into the interior. This is not enough direct solar radiation to cause overheating.
- The shading canopies are therefore sufficient to shade the street facade almost completely during the hot summer months.

We can test and compare the shading throughout the year by using a simple Sketchup model with the correct coordinates for Cape Town



Dec 22 8am



June 22 8am



Dec 22 12pm



June 22 12pm

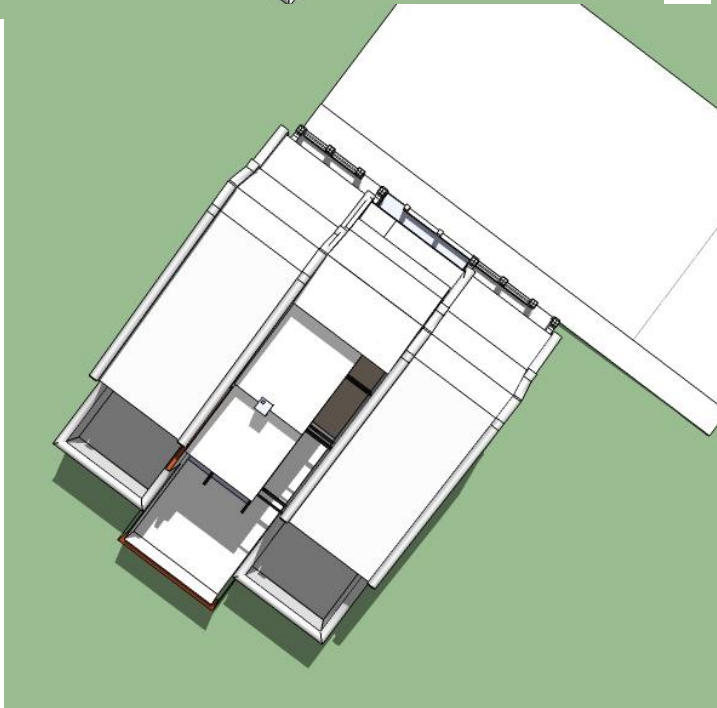
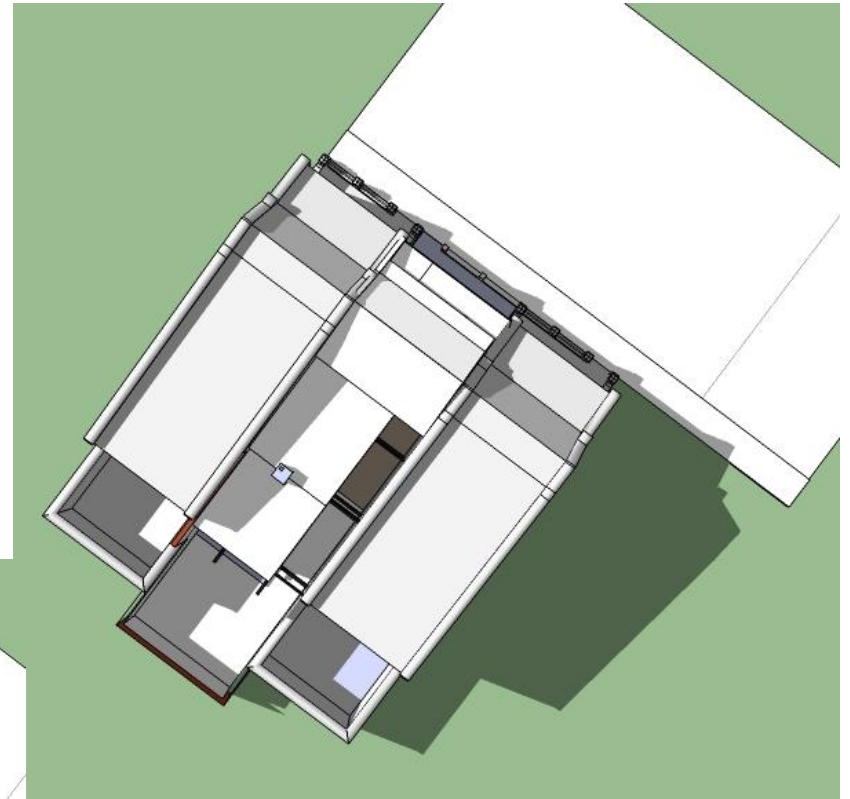
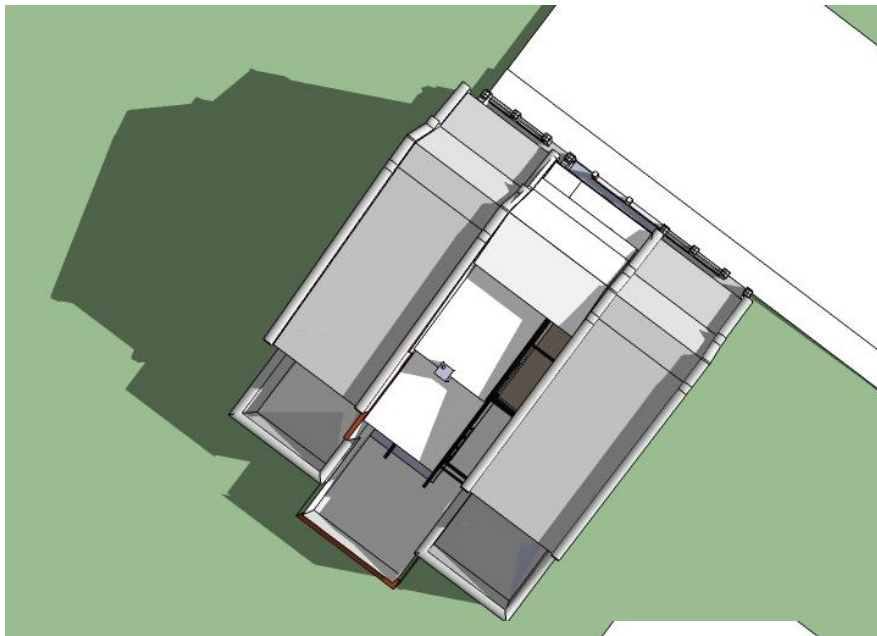

Viewed in plan on sketchup, the shadows indicate the sun's movement throughout the day, as well as the year

A comparison of daylight quality in a bedroom, using a **built model** of the room, Taking photos outside through a peephole. The idea is to get a real sense of the Daylight quality using **real sunlight**.

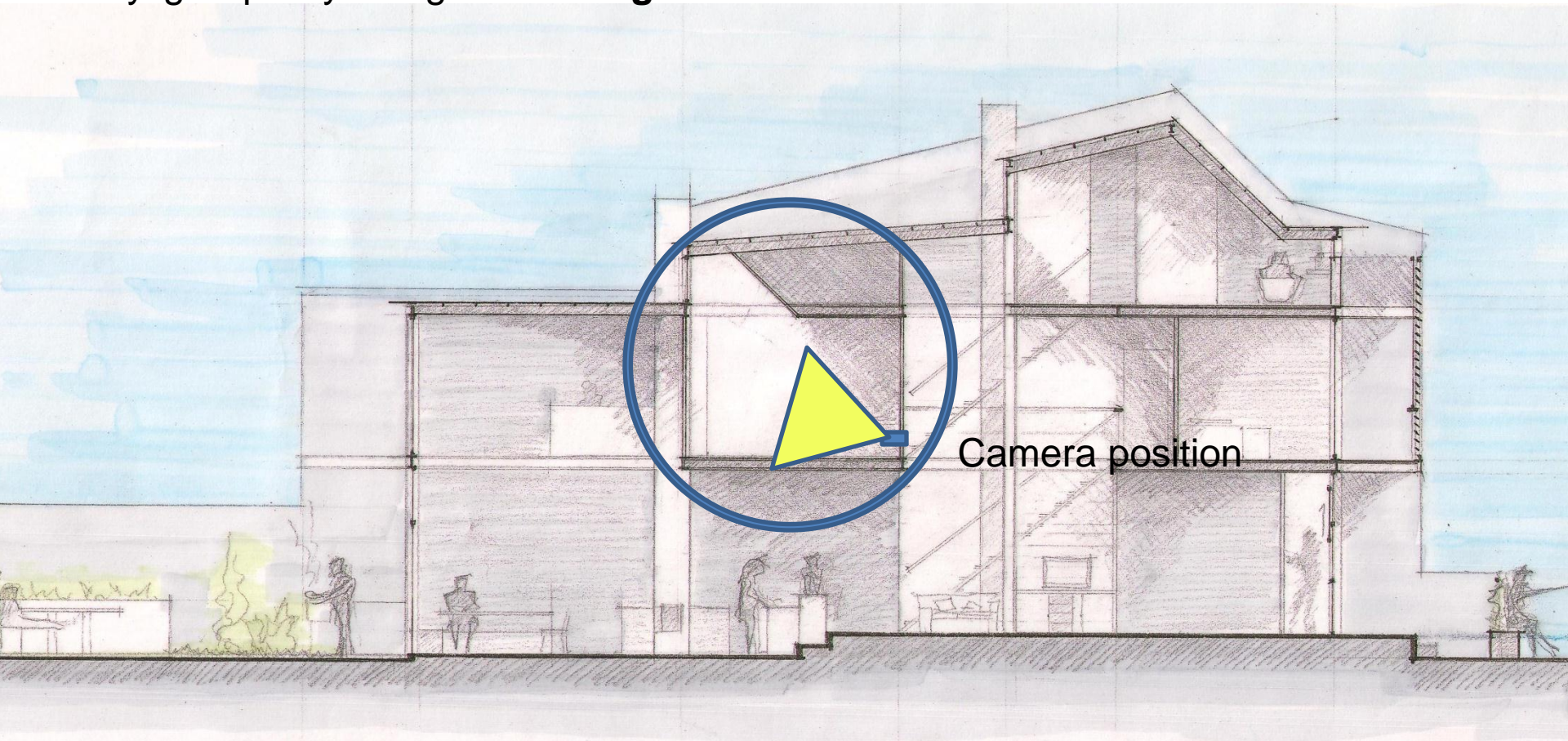

South-west-facing Bedroom, with clerestory window and window onto side Alley.

Are in proportion to one another. A shoebox-size Model is sufficient to produce good photos through a peephole

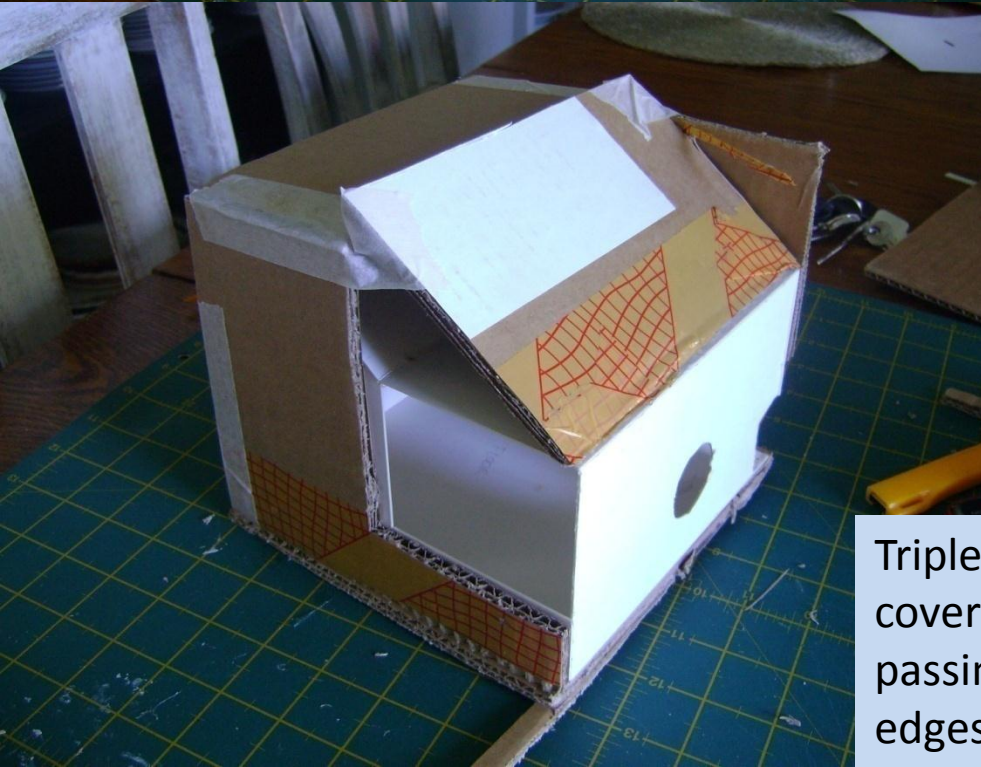
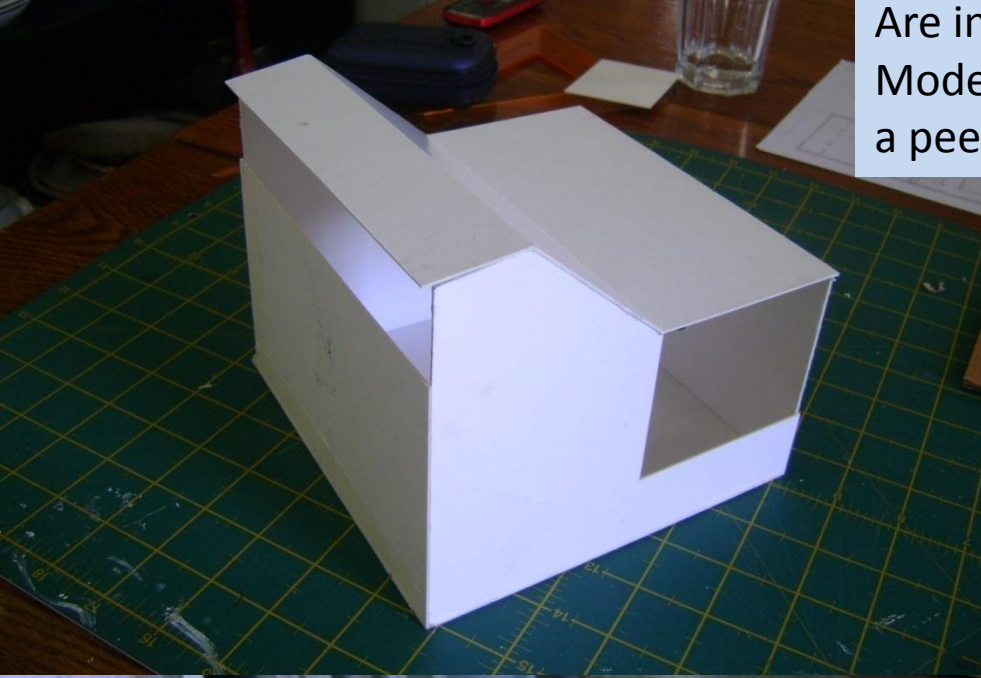

Triplex works well as a white wall finish – it must be covered with cardboard to prevent light from passing through it (it is slightly transparent), and all edges well sealed with tape.

FEBRUARY 13h00



Window without white wall of the adjoining townhouse outside (as if this room stood on an open plot)



Window with existing white side wall, which reflects more diffused and brighter light into the room

FEBRUARY 16h00

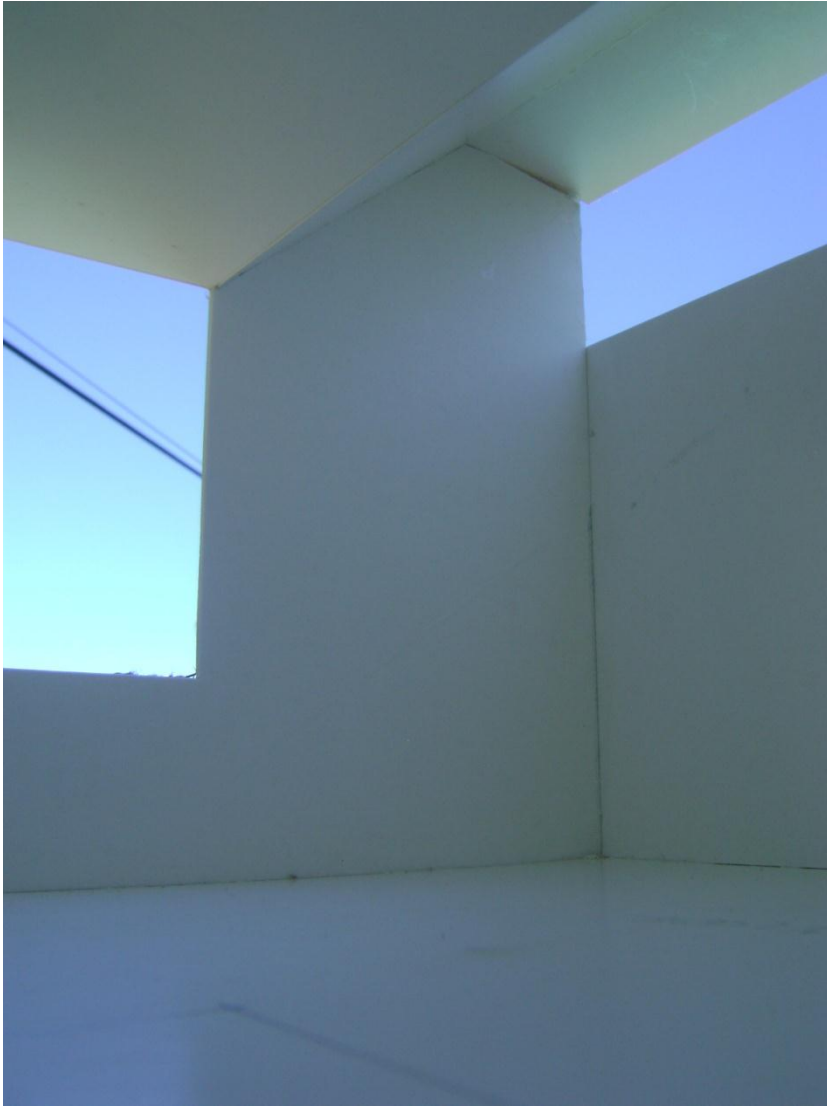

Window without white wall – receives less light in afternoon when sun is on west side where there are no windows



Window with existing white side wall which captures direct afternoon sunlight and reflects it, brightening the room

Late Afternoon – beautiful beams of sunlight
Will enter the room yet will not add much extra heat

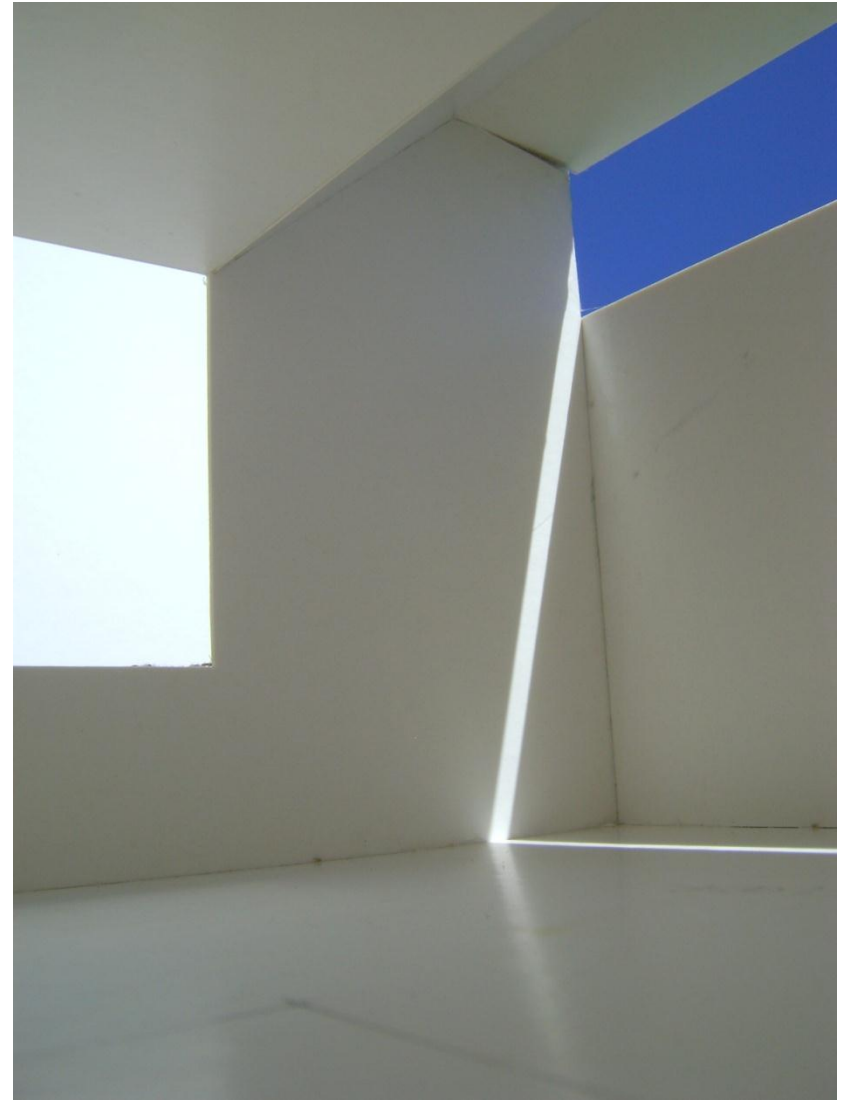

A comparison of daylight quality using **renders** from a Sketchup Model, taken at different times of day at the solstices and equinoxes, using the correct sun path according to the co-ordinates of Cape Town

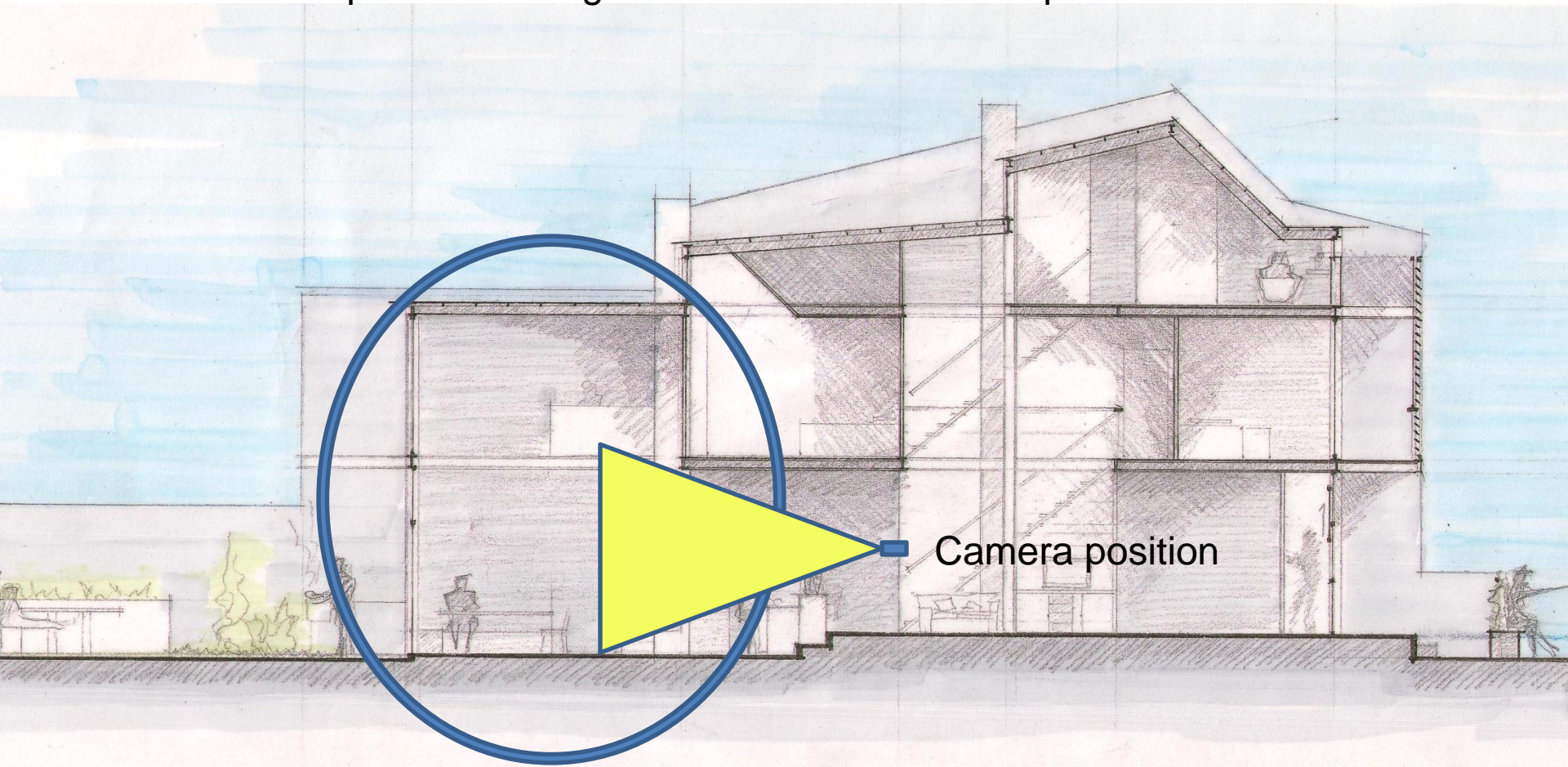

Double volume living area, which opens out to garden

08h00

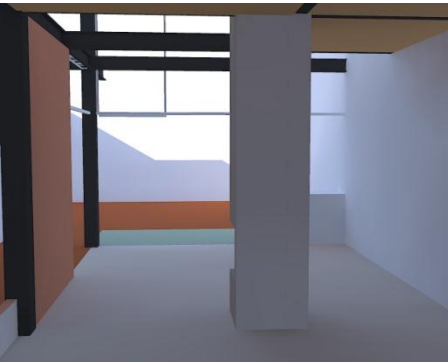

11h00

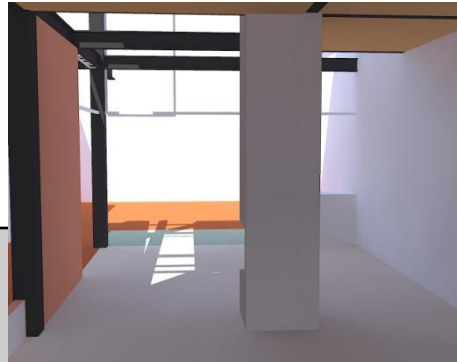

14h00



18h00



22 DECEMBER



22 JUNE

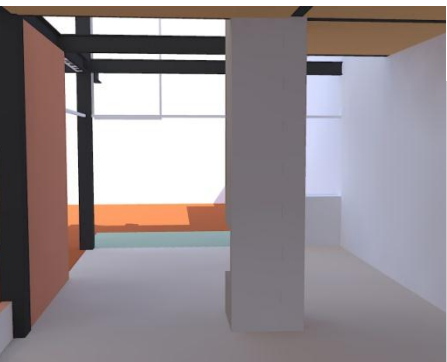
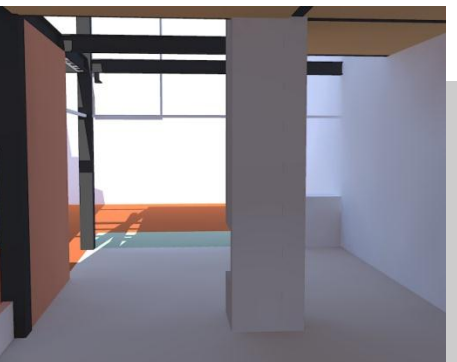
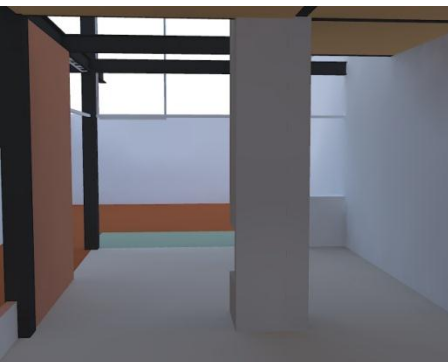

22 MARCH / SEPTEMBER

Contrast between light quality at 18h00 in summer and winter:

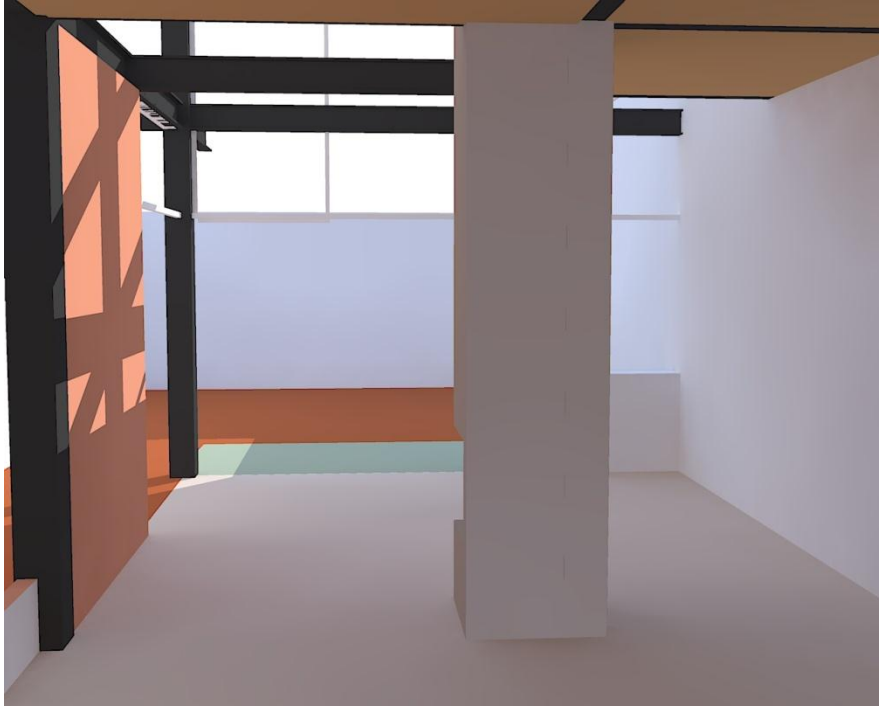

Summer

Sun still high enough to cast rays onto interior walls in its last few hours before setting



Winter

Sun very close to setting at 18h00
Sky becoming dark

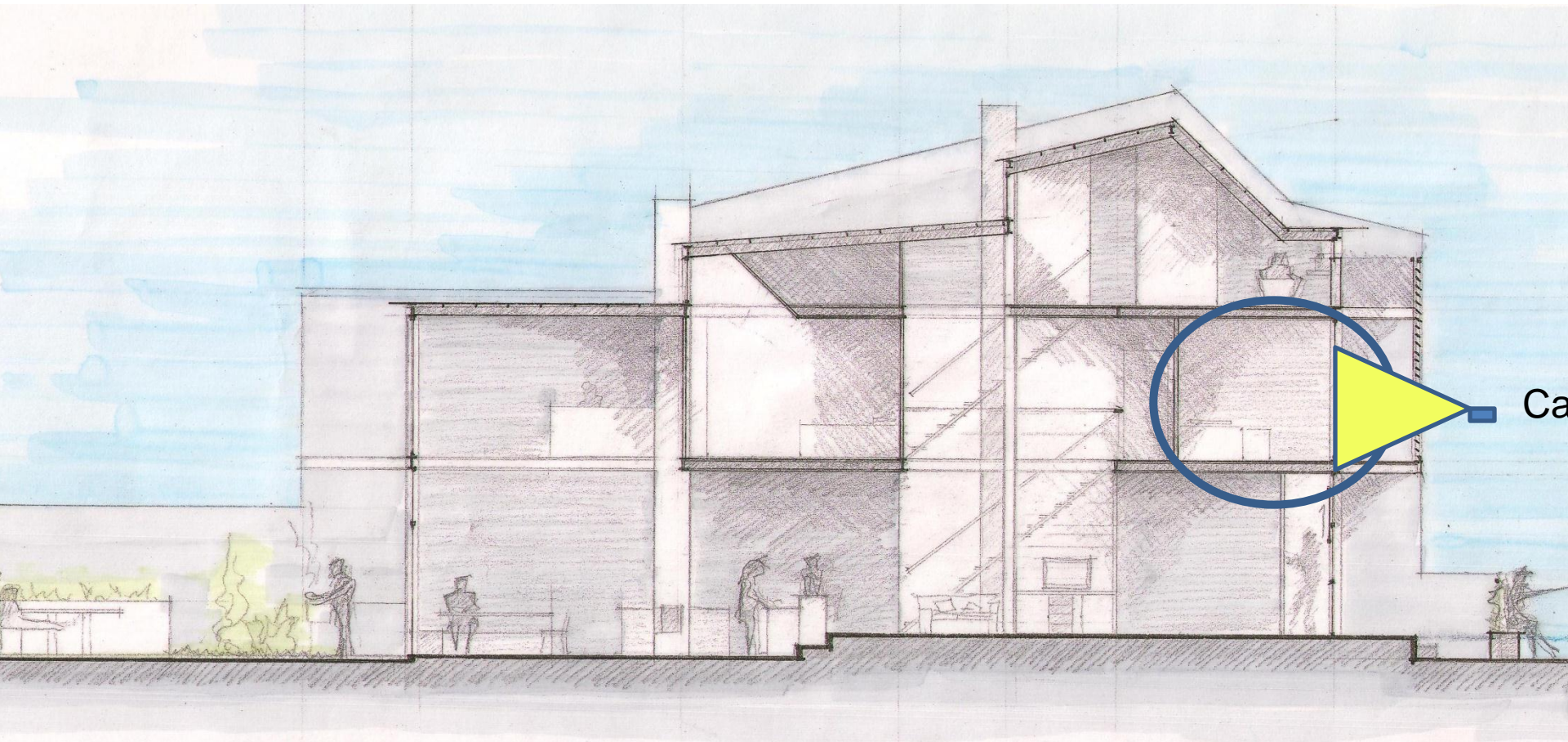

Children's bedroom on front facade, NNE facing

08h00

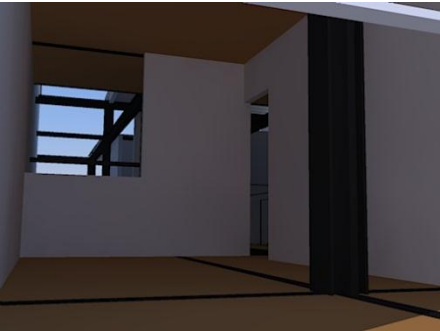

11h00



14h00



18h00



22 DECEMBER

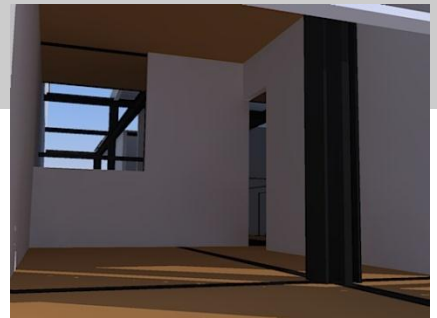
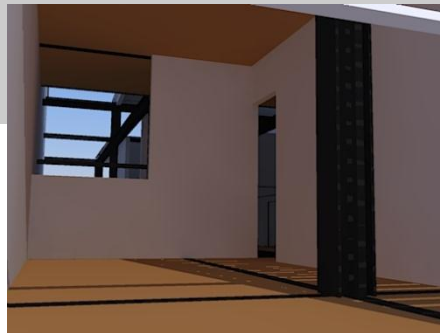
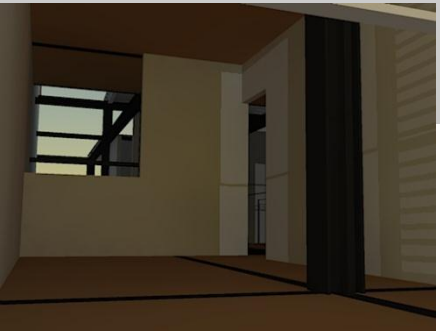

22 JUNE

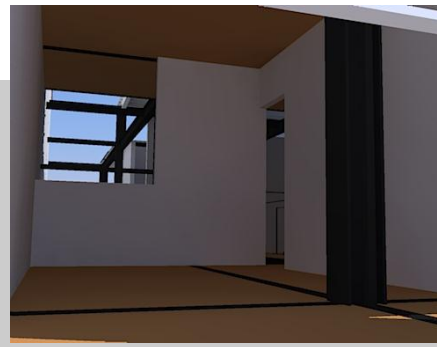
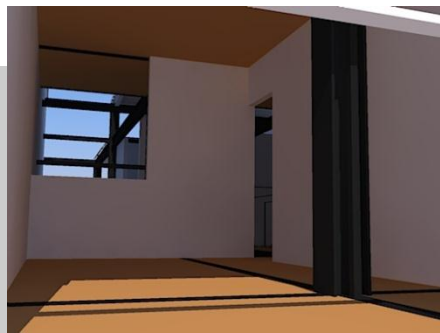
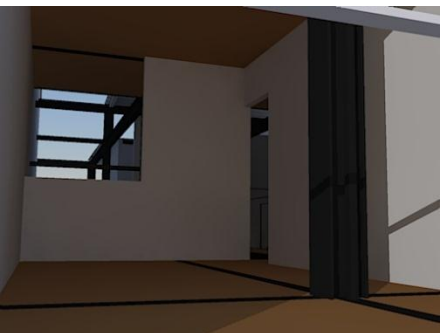

22 MARCH / SEPTEMBER

Difference in sunlight penetration at 11h00 in summer and winter:



Summer

Sunlight falls on balcony but is shaded from entering interior. The sun is at a high angle.

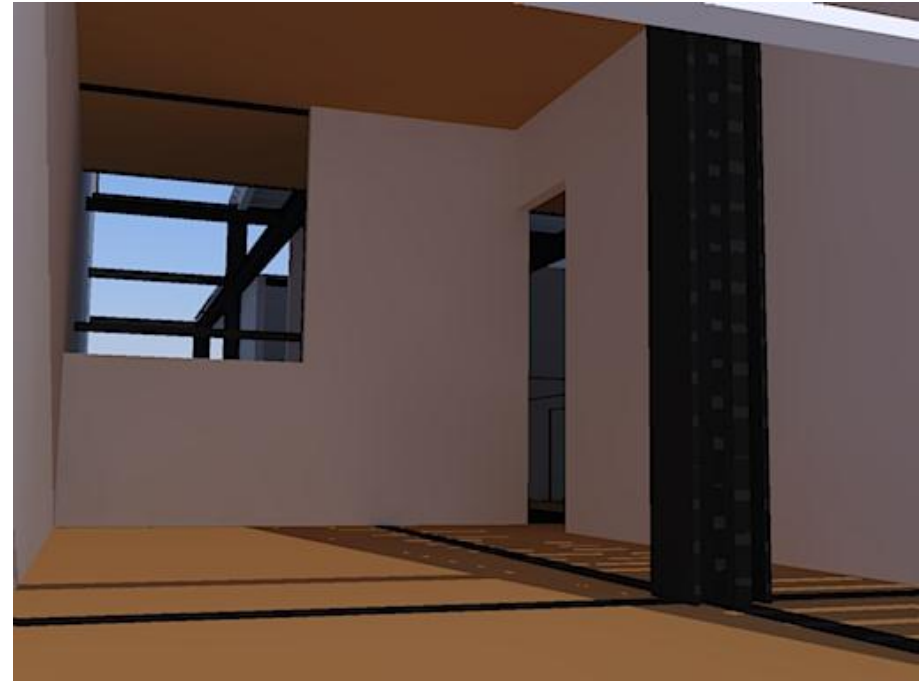

Winter

Sunlight penetrates deep into interior, Warming up the bedrooms in throughout the morning. The sun is at a low angle

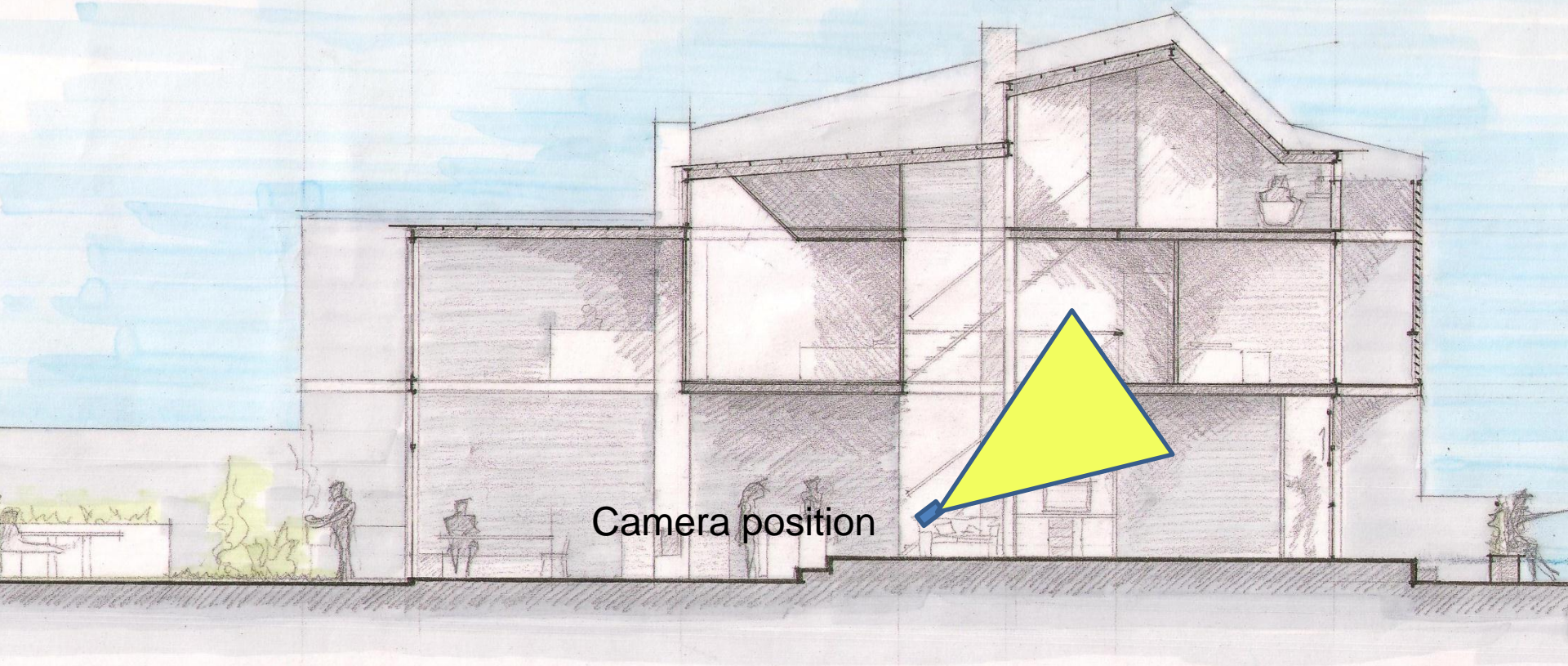

Looking from ground floor up multi-volume stair space, towards bedrooms

It is clear to see that the inside stairwell multi-volume has a **constant diffuse light Quality year-round**. The space does not receive direct sunlight. It is lit by ground floor diffuse light, as well as glazing along the side alley.

08h00



14h00



22 DECEMBER



22 JUNE

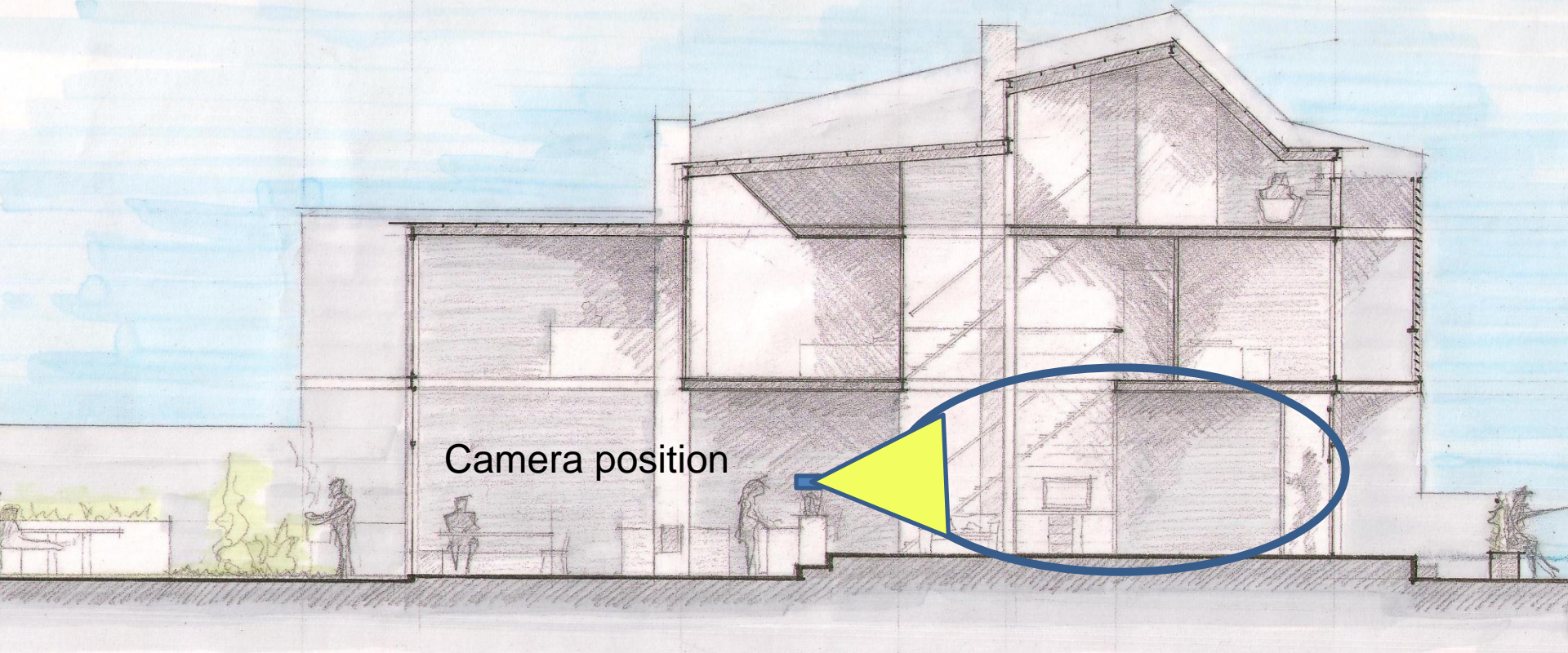

Camera position

- Ground floor entrance hall/ study with street view, NNE facing
- Street views
- Sun penetrates interior and heats it in winter, but is shaded in summer.

11h00



14h00



22 DECEMBER



22 JUNE