

LAYERING TIME: THE REPRESENTATION OF TRADITION IN
CONTEMPORARY MULTI MEDIA PERFORMANCE

By Moratiwa Molema

Submitted in Part-Fulfillment of the Master of Fine Arts Degree
UNIVERSITY OF CAPE TOWN

University of Cape Town

The copyright of this thesis vests in the author. No quotation from it or information derived from it is to be published without full acknowledgement of the source. The thesis is to be used for private study or non-commercial research purposes only.

Published by the University of Cape Town (UCT) in terms of the non-exclusive license granted to UCT by the author.

University of Cape Town

TO MY GRANDPARENTS AND PARENTS

ACKNOWLEDGEMENTS

I am grateful to the students from the University of Cape Town Drama School, as well as the Botswana students located at other educational institutions in Cape Town, and the musicians from Cape Town's extra-institutional diaspora, for participating in *Water Feels* and helping to bring it to fruition. Finally, I thank my fellow students in the Master of Fine Arts course for their encouragement and moral support.

University of Cape Town

CONTENTS

Dedication.....	2
Acknowledgements.....	3
INTRODUCTION.....	5
MOTIVATION.....	7
- Background and inspiration.....	7
- Representation of tradition in dynamic contemporary times.....	10
- Water the natural resource and water the symbol.....	15
METHODOLOGY.....	18
- Conceptual relationships between different art genres.....	18
- Layering time.....	23
- Shooting, editing and presenting video for live performance.....	28
CONCLUSION.....	32
BIBLIOGRAPHY.....	35

INTRODUCTION

As a culminating thesis project for my Master of Fine Arts degree in Film and Television, I chose to create a theatrical production that incorporated multiple video projections as well as performance forms such as dance, drama, music and ritual. This explication then begins with answering the question, ‘how does a student of film and television production engage with live performance and create a theatrical event as opposed to a DVD as a final outcome?’ The ‘why’ lies in the hypothesis contained in the title of the explication “Layering Time: The Representation of Tradition in Contemporary Multi Media Performance.”

I was exposed to multimedia techniques at the University of Hartford in America while pursuing a Bachelor of Fine Arts degree. Through the Master of Fine Arts in Film and Television programme at the University of Cape Town, South Africa, I wished to expand and deepen what I had learnt as an undergraduate student. The result of this effort was my thesis production *Water Feels*.

The theme of the production and the concept of layering time dealt with the importance of continuity and representations of traditional culture in a contemporary world, which is a layering of past and present. As a multi media production, *Water Feels*, was also an exploration of conceptual relationships between different art forms and the potential in this use of mixed media for notions of past and present time to exist simultaneously.

All stages of the production afforded invaluable experiences that have contributed towards my discovering a particular visual style. This style involves the heightening of the event of screening a projection by adding performance to it. A live performance is unique because, unlike film, it can never be repeated the same way twice.

Therefore, each moment during the duration of the performance has an added value.

In this regard then, the size of the surface area for the performance and its relation to the space required for the projected image became a crucial problem to solve quite early in the process. The successful interplay of the media depended on solving the tension between the spatial necessities of projection with the practical and aesthetic

spatial demands of performance. I used three projectors to project from the rear three video frames next to one another that functioned as a single composition on a vertically erected white cloth. This allowed for sufficient space for performance and projection, possibilities to develop complexities of representation through multiple projection and space for projection with and without shadow. The space behind the screen was as important as the space in front of it. (See Floor Plan below).

Floor plan:

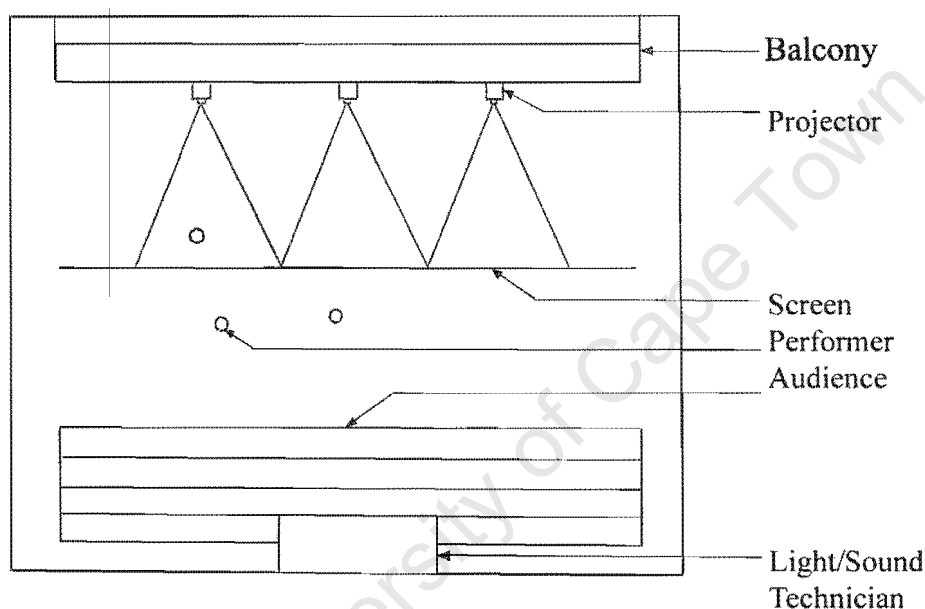

The spatial layout of the performance area then set the site for the interplay of media and the realization of the notion of layering time and the representation of tradition within a contemporary context.

In this paper I will first discuss what motivated the theme and content of the production and the paradox of representing traditional culture in dynamic contemporary times. A discussion on the conceptual relationships between the various art forms and the focus on layers of time follows. Finally an explanation of the methods used to technically realize *Water Feels* is given.

MOTIVATION

Background and inspiration

The stereotype which I intended to counteract with *Water Feels* was the one which has degraded the very foundations and wisdoms of conquered people and their cultures by calling them savage, primitive, backward, and other derogatory names. Concepts such as “botho”¹ and sharing natural resources equally and sparingly are neither savage nor backward. In them lie healing, that I believe can reverse the wounds that imperial, colonial and capitalist systems inflicted upon the environment at large and the lives that live in it.

As a southern African this has been of interest to me because the southern African region until recently harbored two racist settler colonies (Zimbabwe and South Africa) and was ravaged by devastating civil wars (Zimbabwe, Angola and Mozambique), and, in an earlier period, had experienced a full scale genocide (of the Herero people in Namibia, in 1904).² When studying African and European history as a second year student at the University of Botswana, I came to understand some of the features of imperialism and colonialism in general, and was particularly interested in discourses that buttressed the conquest and subsequent domination of conquered peoples, and their administration according to rules in whose formulation they had no say. This was dependent on the degree of subjugation and/or the nature of their response and recovery culturally, economically and politically. Herein lay my first impulse to create the work that I did.

Despite notions of subjectivities that pervade post-colonial discourse, there are certain

¹ Botho means humanity in Setswana and Sesotho. The equivalent in Nguni culture is ubuntu. The phrase ‘Motho ke motho ka batho’ (a human being is a human being because of other human beings) in Sesotho or ‘umntu ngumntu ngabantu’ (You are who you are through other people) in Isixhosa underlie the foundation on which the respective cultures are built.

² In 1970, Radio Botswana carried out interviews with 70-80 year-old Herero men and women, who were born in the 19th century, and who crossed the Namib and Kalahari deserts into Botswana as teenagers, fleeing the German genocide with their families. The interviewers, Margaret Motlatshaping and Leloba Molema, reported in their radio programme, “Go Tla Ga Baherero Mo Botswana,” (the coming of the Herero to Botswana) that a Mr Stephanus Mbingana (80), of Sehitwa near Maung in Ngamiland, pulled out from the rafters of his hut General von Trotha’s signed genocide order promising, in the Herero language, to kill “every man, woman, and child” if the Herero people did not submit to German rule.

notions that may be seen to be universal, such as, for example, the fact that no matter what the paraphernalia of ritual and the geographic, historical and cultural context within which ritual occurs, the expectation of efficacy is true of all ritual. For this reason I had no qualms about putting intimations of a Native American, Iroquois, smudging ritual³ alongside intimations of a Botswana rainmaking ritual (in reality a compression of Tswana and San ritualistic elements), nor did I have qualms dressing white performers from the University of Cape Town Drama School in Tswana impala and springbok skins. I wanted to locate *Water Feels* in South Africa without losing sight of the truism that human beings all over the world transgress, suffer the consequences of their transgressions, and, in the form of ritual, develop entire systems of spiritual healing.

As with ritual, there are certain kinds of truths that are universal, such as the use of stereotype as an alienating device in situations of gross inequality of power.⁴ This can be seen from the slave holding empires of Africa itself, such as old Mali, Songhai and old Ghana⁵ as well as those of Europe such as in ancient Greece and Rome.⁶ In recent times such instances are graphically illustrated in the representation of Jews in Nazi Germany and contemporary stereotypes about Muslims in Christian nations.

The point that I am making is the common-place one that systems that entrench gross inequalities of power, and which police,⁷ literally and otherwise, the boundaries that they have set up between dominant in-groups and subordinated out-groups exist all over the world. And with them, fixed stereotypes are perpetuated as a method for 'othering' and to rationalize the imbalance in power relations. In several parts of the world this continues to cause suspicion, division and alienation.

³ Dried sage (*Salvia apiana*), Cedar (*Juniperus virginia*) and Sweetgrass (*Hierochloe odorata*) are burned and the smoke is gathered closer to the body. Sometimes one person smudges another using a feather. This action is accompanied with prayer. The smudging ceremony originates from Native Americans.

⁴ See Stuart Hall's "The Spectacle of the 'Other'" in Stuart Hall (ed.), *Representation: Cultural Representations and Signifying Practices* (London: Sage Publications, 1997), 225 - 279.

⁵ Roland Oliver and JD Fage, *A Short History of Africa*, Sixth Edition, (Harmondsworth: Penguin Books, 1988).

⁶ Orlando Patterson, *Slavery and Social Death: A Comparative Study*, (Cambridge, Mass. and London: Harvard University Press, 1982).

⁷ Stuart Hall op. cit.

In my attempts at creating an integrated whole of the work *Water Feels* with due consideration to notions of layering time and the complexities of representing indigenous tradition, it became clear that the contemporary political landscape in which the narrative is contextualized cannot be ignored. In South Africa, the society at large is undergoing transition, with the main intention being to transform the country and society into one that is based on a human rights culture. This is a unique experiment, because the definition of human rights has been extended to include the so-called “second generation rights”, namely the rights to housing, a decent and dignified style of life, the rights to basic amenities, and so forth. The post-apartheid era is a very dynamic one because it involves the creation of new identities, as well as the redefinition of existing identities, not only in South Africa, but across the entire Southern African region.⁸ *Water Feels* is centered and structured around the theme of cultural and racial integration. It recognizes the reality that under apartheid and colonialism the conquered and oppressed adopted the very basic survival tool of assimilating the culture of the oppressor. This is reflected not only in the fact that many indigenous Africans can speak English or Afrikaans or the fact that they give their children English or Christian names, but even typically have two wedding ceremonies – a traditional African one and one derived from Christian and European tradition. The concept of assimilation is further reflected in the fact that in all the essential ceremonies of human life – birth, entering adulthood, entering into a lasting relationship with a partner and death – the oppressed have partnered their traditional ceremonies with a ceremony borrowed from the oppressor. Whether the act of borrowing a ceremony from the oppressor had any impact on the culture and cultural ceremonies of the oppressor still has to be subjected to rigorous examination.

However, in the course of resisting colonial conquest and struggling against apartheid, the people of South Africa, often in close collaboration with the broader community of Southern Africa, developed a culture of resistance. The essence of this culture was that the very act of daily survival was an act of resistance, an act of defying the devastation wrought by apartheid. The resistance movement recognized this and used the concept of “The Spirit of No Surrender” as a basic tool in building the morale of

⁸ Books that go into detail about this phenomenon are *Whiteness Just Isn't What It Used to Be: White Identity in a Changing South Africa* by Melissa Stein and *Under Construction: 'Race' and Identity in South Africa Today* edited by Natasha Distiller and Melissa Steyn.

its fighters.

It is this spirit that motivated me to strive for balance in my production by using different cultural formations as a way of achieving a sense of unity in diversity. The manifestation of these varying cultural formations could be found in the wide range of dance styles, text, sound and costume that pervaded the production. Tswana traditional dance for example found its place alongside contemporary dance and gesture, as did traditional chants with English text.

The cast that was made available by the drama school to the production of *Water Feels* was mainly white. The fact that the production had to rely on a white cast dressed in traditional Tswana costume, having been taught the songs and clapping rhythms, and appearing alongside the traditional Tswana dance troupe that also appeared in the production, gave the production an added meaning. The production process of *Water Feels* created the unique and exhilarating feeling of being at the frontlines of cultural transition, where different cultures of South Africa, black and white, integrated and practiced indigenous African culture. It was a role reversal of sorts, a marked departure from the colonial experience, which saw cultural transmission mainly emanating from the colonizer and imposed on the colonized.⁹

Representation of tradition in dynamic contemporary times

After considering the background and beliefs from which I derived the underlying theme of *Water Feels*, an opportunity soon arose to critically analyze my own attempt to capture, preserve and transmit past and present experience using multimedia tools. This attempt was paradoxical for several reasons. Firstly, when one talks about 'past and present experience' and when one seeks to 'capture and preserve' it, the assumption is that this experience is true and authentic in itself because it happened and empirical proof can be assembled to demonstrate that it did indeed happen. Experience, then, is authentic only at the time of actual happening, and the paradox that arises is that all attempts to 'capture' and 'preserve' it are merely a recollection, a re-invention, a re-creation. A work of art such as mine is only an approximation of

⁹ Wally Mongane Serote, *Hyenas* (South Africa: Vivlia, 2000), 3 – 23.

that experience, an attempt to the best of my ability to render it again as exactly as possible and so re-live it with others. At this first level *Water Feels* is, up to a point, concerned with what may be called the poetics of representation.

Secondly, my seeking to 're-live' the experience with others (that is, the attempt to transmit it, to communicate it) is itself paradoxical because my representation of it is a construct that itself produces meaning, outside of the experience itself, but within the codes of visual language held in common by the members of the community of which I am also a part. At this second level, *Water Feels* is concerned with the politics of presentation. It deals with concerns about the exercise of power, by whom and on whom; what influences how we think or practise things and how we construct identities.

Thirdly, at the level of transmission or communication or 'reliving of the experience with others,' paradox arises because these other people with whom I want to share the experience, are never passive recipients of any meaning, but active interpreters of it. As a result meaning is not fixed because it responds to context and time and shifts as these shift.

The United Nations Educational Scientific and Cultural Organization (UNESCO) states that culture is the "set of distinctive spiritual, material, intellectual and emotional features of society or a social group and that it encompasses, in addition to art and literature, lifestyles, ways of living together, value systems, traditions and beliefs".¹⁰ Over time, cultures undergo transformations. "When attempts are made to keep a cultural identity 'pure,' the realities of social change, via natural and artificial means, dictate that cultures do not remain 'pure,' rather they are destined to change."¹¹

'Moving with the times' has implications not only for culture but also for cultural practitioners and art makers. By shedding old skin and transforming shape and size,

¹⁰ http://www.unesco.org/education/imld_2002/uneversal_decla.shtml.

¹¹ Fernando Ortiz, "Fernando Ortiz on the Phases of Transculturation: Speech made at Club Atenas in Havana, December 12 1942" In *J.A. Sierra History of Cuba.com*, [Online]. Available: <http://www.historyofcuba.com/history/race/ortiz-2.htm>

the old may disappear physically because of changing media but may live on in new forms (which in the case of *Water Feels*, is by using digital technology to express ancient traditional values) because the essence remains in a new skin. If the shedding of the skin does not occur, younger generations lose a connection with the old, and it ceases to live on. If the transformation occurs, a reinvention takes place and continuity is created. As Bhabha states, “Such art does not merely recall the past as social cause or aesthetic precedent; it renews the past...”¹²

An example is when Miles Davis, the legendary trumpet player, in one of his last albums *Doo-Bop* in 1991,¹³ was one of the first musicians to merged jazz with hip-hop and planted a seed of heritage into the new, emerging music culture that cannot be denied today. The hip-hop experience itself is an art that renews the past having its roots in the African tradition of praise poetry and the oral tradition of passing on the history of the group through tales and stories. Jazz¹⁴, in one of its many lives, lives on in many music genres like hip- hop and house music.

Another example of the old in the new can be found in how some Nigerians used the photographic camera, which came to Africa with the colonizing forces. They took ownership of the image and applied it in an African context. Among the descendants of the Yoruba of the old Oyo Empire, the photographic image would be used in the same manner as the Ibeji sculpture, kept on the altar to twins and brought out for rituals. Here Ibeji, or twin images, are images that honor the dead, which the living nevertheless tend and nurture as though they were the child in whose honor the twin images were made. Originally they were made out of wood and produced by a sculptor that a priest appoints. Then, upon production they were made sacred for the purpose of honoring the dead twin or twins. According to Stephen Sparge,

“Photographs are often made of twins and other children to hang in the parlor with the photographs of other family members. Then, if the child dies, there is a

¹² Homi Bhabha, *The Location of Culture* (London and New York: Routledge, 1994), 7.

¹³ Miles Davis teams up with producer Easy Mo Bee. The sound is more in league with England’s acid jazz scene.

¹⁴ Jazz is structured in its origins in blues and the lives of slaves

portrait by which to remember him. The process becomes more complex when one of the twins dies before their photograph is taken. If the twins were of the same sex, the surviving twin is photographed alone, and the photographer prints this single image twice, so that the photograph seems to be sitting side by side in the final photograph . . . the photographer attempts to conceal the line blending the two separate exposures in order to maintain the illusion of twins sitting together in a single photograph.”¹⁵

Photography offers the unique ease of combining possibilities of precision, which are otherwise not readily available to the human agent, with those of malleability required for the fulfillment of the essence of the image. In this culture, photography is simply another process of image making, a process of *making* rather than *taking*.¹⁶

“Traditional materials can be modified by new techniques or old techniques can be applied to new materials. Often these developments have interesting implications for the image”.¹⁷ The sculpture *Business Man* from the Spier Collection in Cape Town, South Africa, made by Collen Maswanganyi, is an abstract wooden sculpture stylistically carved in a way that is reminiscent of traditional African carving, yet the figure that is depicted is an African man in a black suit, carrying a briefcase and talking on a cell phone. The one dimension is represented with the medium (wood), and the style in which it is carved is traditional (old); and the other dimension is modern (new), which is represented by the context in which the figure finds itself. The relationship between the two polarities is conceptual and in itself creates a social discourse pointing to the notion of continuity and change in cultural formations. (See image 1).

¹⁵ Stephen F. Sparge, *Yoruba Photography: How the Yoruba See Themselves*. African Arts, November 1978, xii, qtd. in Nicholas Mirzoeff, *The Visual Culture Reader*, (Second Edition, New York: Routledge, 2002).

¹⁶ Olu Oguibe, “Photography And The Substance Of The Image,” qtd. in Nicholas Mirzoeff, *The Visual Culture Reader*, Second Edition (New York: Routledge, 2002), 579.

¹⁷ T.E. Batten (Amsterdam: Jan/Jul/Aug 1996) “So what is Media Art?”

Image 1



I am aware that there is a fine line between such rich representations of cultural practices and those that can obfuscate and reduce. Olu Oguibe, writes about such instances where traditional belief systems are exploited by taking rituals or ceremonies out of their cultural context.

“Nicolas Monti has indeed suggested, and with much merit, that the culture of tourism has its very beginnings in the lucrative trade in photographic images of Africa. As adventurers and colonial personnel applied the photographic process to the graphic representation of aspects of African and Maghrebian life, many were drawn to the continent not only by the geography thus revealed but also by a new, more convincing and eminently enticing portrayal of the alleged sensuality of the African. So successful was this commerce of images that by the turn of the twentieth century, the American

photographer F. Holland Day was manufacturing studio images of “Nubians” and “Ethiopians Chiefs” shot in America and modeled by African Americans, a voyeuristic, typecasting practice that would eventually manifest, in its worst form, in the jungle-fiction of Africa that preoccupied Hollywood in the century that followed.”¹⁸

Even today when I travel to the United States of America or the Caribbean Islands, irrespective of the educational level of the asker, I am still asked whether Africans live in trees and in the ensuing discussion there is surprise that there are such inventions as cars in Africa! The processes of the kinds of manufactured perception that Oguibe talks about certainly run deep and continue to inform the kinds of prejudice that are prevalent.

Water the natural resource and water the symbol

The idea to use water as a major theme was motivated by the fact that according to a United Nations (UN) report released on BBC news “more than 2.7 billion people will face severe water shortages by the year 2025 if the world continues consuming water at the same rate. The looming crisis is being blamed on the mismanagement of existing water resources, population growth and changing weather patterns. The areas most at risk from the growing water scarcity are in semi-arid regions of sub-Saharan Africa and Asia.”¹⁹ I wanted to produce a work that would encourage the wise use of this scarce natural resource.

Water also has infinite, intricate textures and infinite sound possibilities when it is massed in lakes and oceans, or flows in rivers and brooks or falls as raindrops. Water has a soothing, healing and calming effect on the human body. The human body is composed of 60% to 70% water, which makes it a good conductor of sound, and according to Mr. Masaru Emoto, study, thought and intention as well. In his book,

¹⁸ Olu Oguibe, “Photography And The Substance Of The Image” in Nicholas Mirzoeff, *The Visual Culture Reader* Second Edition (New York: Routledge 2002) 566.

¹⁹ Friday, 22 March, 2002, BBC News. <http://www.bbc.co.uk/1/hi/world/1887451.stm>

Messages from Water, he investigated, with a dark field microscope that has photographic capabilities, the effects thoughts have on the molecular structure of water. He took pictures of polluted water from the Fujiwara Dam in Japan before and after Buddhist monks had offered a prayer over it. According to his pictures sound coupled with intention restored the water to its natural geometric symmetry.²⁰

The initial intention was to facilitate a platform on which all present at the production could send out intentions to water and make the audience aware that sounds, thoughts and intentions have an impact on the body on a cellular level, because of the effect thoughts have on water. The idea of a community making a joint effort by sending intentions to the universe to cause rain in a rain-making ritual was related to the fascination with Mr. Masaru Emoto's work.

However, water also features in the nexus of archetypal metaphors of renewal, such as in some versions of the European legend of the Fisher King, who annually, in Spring (itself a symbol of new beginnings) took upon himself all the evil deeds, guilt and bad blood of the community he ruled and walked into the sea and symbolically drowned himself together with his burden of his people's malaise, only to emerge reborn, king himself is the cause of the real and spiritual wasteland, and is sacrificed as a kind of scapegoat and replaced by a youthful heir, whose fresh good looks are reflective of the full waterways and green plants on which the people depend for sustenance.²¹

In Ngugi wa Thiongo's novel, *The River Between*,²² Kikuyu boys undergoing

²⁰ Masaru Emoto, *The Hidden Messages in Water* (Oregon: Beyond Words Publishing, 2004) (See too, WellnessGoods.com "Miraculous Messages from Water: How Water Structures reflects our Consciousness." [Online]. Available: http://www.life-enthusiast.com/twilight/research_emoto.htm [2008, October 20]

²¹ Jessie L. Weston, 2002. From Ritual to Romance, Tenth Edition, Project Gutenberg Online Reader. E-text #4090 (Cambridge: Cambridge University Press, 1920). Both Jessie Weston and Sir James Frazer, to whose *The Golden Bough: A Study of Magic and Religion* she admits gross indebtedness, have been criticized for their accrual type methodology, with which they justified the links they saw between the rituals of the world's cultures. Instead of providing empirical evidence for an immemorial original source of all these rituals, they piled up more and more examples of such similarities from all over the world. Unlike their counterparts, the linguists, who researched the Indo-European languages, they had no ancient Sanskrit documents to go by. My own concern has only been to say that rituals have been performed and are still being performed all over the world, and no matter what the historical, geographical or cultural location, those who participate in them expect them to be efficacious. The mere collection and listing of these rituals by Weston, Frazer, and other scholars of their generation and after, have thus served my purpose quite well.

²² London: Heinemann, 1965.

circumcision do so on the bank of the Honia River. The blood (a symbol of life) from the sexual organs (another symbol of life) of the initiates drips onto the earth (yet another symbol of life). Later in the ceremony, the initiates are bathed in the river, thus symbolically leaving their childhood behind, only to emerge from the river symbolically reborn into the men that they are expected to become. Christian baptism also falls in this category of symbolic death and resurrection by water.

If water stands for life, plenitude, healing, rebirth and renewal, then its absence brings us to yet another meaning of it, one which is equally a nexus, but this time of all that negates life, plenitude, healing, rebirth and renewal. The juxtaposition of water and the absence of it, taken together with the networks of symbols that arise from this juxtaposition, apply not to society only, but also to the individual human beings who comprise society. It is possible for a single person to be an expanse of lush, green, well-watered vegetation or a whole Sahara Desert or both, at various times and in various circumstances in the course of his or her life. These networks of association are what I wanted to coax the audience of *Water Feels* into participating in, and thinking about.

I wanted to communicate my experience and perception of the world in such a way that it resonated with the audience. I wanted *Water Feels* to reflect back their own insights without me talking at them, and I wanted them to make new connections, if these did not already exist, between how they think (or do not think) and how they live. A major motivation of mine was to engage the audience by providing an uplifting experience through resorting to ritualistic structure, and by linking the theme of mindless, self-centered consumerism (one of the figurative deserts hinted at earlier) to the depletion of natural resources, in particular, water. The ultimate aim of my production, then, was to revitalize, if not change, the consciousness of the audience, that is, their "being". However, conscious as I became of both the potential and limitations of performance, I realized that I would have been satisfied if I provoked their awareness at a level where the only realization was that there is a practical need to save water.

METHODOLOGY

Conceptual Relationships between different art genres

One is able to manipulate perception to varying degrees in the use of video. The shapes and figures of a video projection have an intriguing phenomenon, which is to appear to have form (including depth). The image itself of course, is actually flat when it lands on the surface it is projected on. What causes this illusion are the tints and shades of colours or the tones of grey, in the case of black and white film and video, that make a two dimensional property look as if it is three dimensional. Form is an optical illusion in video, photography and painting. The proportions in relation to perspective and depth of field make the images look life like. A projected video image has not only a photographic quality but also gives the impression of seeing a moving image. The smoothly moving picture is a sequence of thousands of slightly different still images (frames) projected in rapid succession. The human eyes cannot see bursts of blackness in between the 24²³ still frames projected per second. The eye and mind are fooled into seeing movement. The combination of the illusion of movement and form give film and video an advantage in its representations of reality perceived by human beings, especially when the images are not stylized and sound is included. It is said that during the first screenings in film history by the Lumiere brothers in 1895, spectators who had not been exposed to film what so ever, screamed and dodged²⁴ when they watched *L'Arrivee d'un Train en Gare* (The arrival of a train at the station), because it looked so real. In this short film the virtual train approached, from a long shot to close up.

In *Water Feels* the “real” looking video and the realness of live performance were stylistically attractive because they look similar but have such a range of differing properties which make the combination of these forms a potentially rich site for layered discourse. Video and live performance are both time-based media. The performance on screen or on stage last from the beginning to the end. Both thrive on

²³ Film cameras record 24 frames per second. Less frames recorded per second cause flickers which can be observed in very old films

²⁴ Eric Barnouw, *Documentary: A History in Non-fiction Film* (New York: Oxford University Press, 1993), 8.

movement and action. I used these similarities in *Water Feels* as a visual and metaphorical bridge to build conceptual relationships between the two art forms. The conceptual relationship, according to my personal taste, worked best when I found ways to create optical illusions in which the images appeared to transcend the limitations of the media. The two dimensional property of the projected image became self-reflective when it was contrasted with the three dimensional live figure, with a string attached to the vertically erected screen or with smoke from a smoke machine.

For example, during the performance one end of a string was tied to the hair of the performer and the other was attached with a needle to the screen. The point where the string touched the screen was exactly where the projected image, a woman painted in red colour, had her hand stretched out pretending to be holding the string. It looked as if the projected image was holding on to the performer by a string.

Image 2 and 3 below are of two different perspectives of this scene:

Image 2



Image 3



The two separate media each carrying a possible meaning, became physically connected. The connection sparked a new meaning. The woman in the projected image represented a nonphysical dimension. The fact that a projected image is something that cannot be touched became more emphasized when contrasted against a live figure. The woman in the projected image looked like she was holding the tangible figure, who acted in the scene as if her movements were restricted. A possible meaning of the visual metaphor was that the intangible dimension that exists has effects on the physical world.

Another example of how an optical illusion worked successfully was after a hole had been cut in the vertically erected cloth. The hole was big enough for a person to climb through. Smoke coming out of a smoke machine that was placed behind the vertically erected cloth crept through the hole. The projected image on the vertically erected cloth was of a cloud. The smoke, which held some of the digital information in the light from the projector, looked like a cloud. It looked as if the flat image was spilling into a third dimension (see image 4).

Image 4



In this particular scene the space behind the vertically erected cloth had a metaphoric meaning in the narrative. It represented the “unseen”, or the subconscious mind, or an altered state of consciousness, or what is described as the world of ancestors. A collision between the various components such as the projected image, smoke, space and narrative, which each separately represent their own quality occurred. Subsequently the coming together of all the elements “resisted the inner nature of language and linear representation of history by creating an abundance of possible meanings”²⁵. Soeke Dinkla, calls this a “network of associations”²⁶. I refer to the “network of associations” as the conceptual relationships that create an integrated whole when more than one art form is combined. Soeke Dinkla goes on to explain that “a floating intellectual space emerges, a space of the unsaid of what is on the tip of the tongue.”

It is this “floating intellectual space” that in the conceptualization and execution of *Water Feels* I continually intended to facilitate. I wanted to give the audience a space to engage their minds creatively, by finding meaning for themselves, and thus become

²⁵ Martin Rieser and Andrea Zapp, *New Screen Media Cinema/Art/Narrative* (London: bfi Publishing 2002), 36.

²⁶ Martin Rieser and Andrea Zapp, *New Screen Media Cinema/Art/Narrative* (London: bfi Publishing 2002), 36.

engaged in the show. In the particular style that I am discovering and exploring, ambiguity is a deliberate feature. The style of ambiguity resonated with the fact that in the realities of shifting cultural perceptions and representation not everything can be explained; it remains a mystery. “The unsaid” acted as a negative space of the said. I wanted the “unsaid” to be felt by using as little speech as possible, foregrounding the visual metaphors. The “unsaid” was also present as a feeling of upliftment, present at the end of rituals which in my experience, produces a sense of an encounter with something intangible. I hoped the “unsaid” or the mystery spoke for itself in the minds and hearts of the viewers.

The conceptual relationships between video and performance worked as well when no optical illusion was created. In the case of the image 5, the relationship was between the projected image and a shadow that was cast onto the vertically erected screen by rear projection. The human figures interacted with the projected image in ways that were meant to elicit direct and indirect interpretations. The proportions of the projected image in comparison to the human figures were not correct and gave the overall image an abstract feel. The abstraction and non-realistic dimensions placed the image firmly in contemporary discourse.

Image 5



Layering time

Video projection and live performance are both time-based media. It became imperative for me to explore how notions of time operated in the production and how maximum use could be made of both media. This especially with regards to the development of relationships that would complement the complexity of the subject of representing tradition within a contemporary context. It was important also to develop a coherence in this simultaneous representation of different kinds of time.

The media video and film, have permitted time to be represented as a succession of still images (frames). Time has been mapped onto a two-dimensional space and is available for manipulation to the editor who can rearrange time by using shot changes, as happens, for example, in flashbacks and flash-forwards. In the book *House of Hunger*, written by Dambudzo Marechera, the main character sits in a bar for two hours, and during that span of time, he tells the story of his life. Paul Hirsch, the editor of *Star Wars*, noted about editing film and video, that “You can span thirty years within an hour and a half. You can stretch a moment in slow motion. You can play with time in extraordinary ways.”²⁷ In film and video, compressions of time are made possible with conventional shot changes such as elliptical editing or cutaways²⁸, where actions are presented in ways that consume less time on screen than they do in real life.²⁹ I spanned several hundreds of years in half an hour in both the filmed and staged representation of a traditional ritual, a key component of *Water Feels*, at least in so far as ritual practices of human beings date back to remote antiquity.

Live time is the experience felt when moving from moment to moment in the present. It appears to be a “non-spatial linear continuum where events occur in an apparently irreversible order”.³⁰ Live performances are experienced in that way. Within the moving image industry, features such as live broadcasts, web cams, real-time videos

²⁷ David Bordwell and Kristin Thompson, *Film Art: An Introduction Sixth Edition* (New York: McGraw-Hill 2001), 260.

²⁸ Elliptical editing includes punctuation shot changes such as wipes and dissolves or a cutaway which is a shot of another event elsewhere that will not last as long as the elided event.

²⁹ David Bordwell and Kristin Thompson, *Film Art: An Introduction Sixth Edition* (New York: McGraw-Hill 2001), 260.

³⁰ Found on I-net, unable to find original source. <http://en.wikipedia.org/wiki/Time>.

on the internet, time moves at the same pace as live time. New Media artists, for example, have used virtual space on the internet to exhibit performances happening in different locations at the same time on one web page as they are happening. Artists have used live-feeds during performances where the act of filming becomes part of the performance and a comment on the process of viewing, Such a technique was used to profound effect and social comment in a Magnet Theatre production, *Rain in a Dead Man's Footprint*.³¹

In *Water Feels* a live-feed was used to foreground the act of viewing and representation but also went on to effectively foreground consumerism. In one scene, a performer dressed in a traditional Tswana costume filmed an actress who held a picture frame in such a way that it framed her, whilst she was doing a monologue. She emphasized the word “I” whenever she said it. The scene expressed individualism and the mentality of consumerism. The effect of the live-feed, as both the actress as well as her double back projected images were being filmed and projected, was a bombardment of infinite reflections of her projected image. This brought an acute sense of both consumer culture as well as layering in time. (See image 6).

Image 6



³¹ Magnet Theatre, *Rain in a Dead Man's Footprint*, performed by Jazzart Dance Theater, directed by Mark Fleishman, Cape Town, 2003.

Actions that have been recorded on film or video occurred in the past. The projecting of a recorded image is a replaying of what happened in the past. However that does not necessarily mean that the recorded action represents a past action. The actor, for example, could have pretended to be a character in the year 3002.

I want to expand further the notion that the moment in performance I have described above is an example of layers of time. Live time in the form of the performance was layered with recorded time, which was represented by the two images of the woman facing each other. Projecting a recorded image is replaying what happened in the past. The action portrayed may be a representation of the past, present or future and adds yet another representation of time.

The narrative of the entire work that took place metaphorically during one cycle of the moon, lasted thirty minutes, which implies a sense of compressed time. In the instance above, the performer dressed in traditional Tswana costume and holding the camera represented historical time. The actress performing the monologue about herself was dressed in contemporary clothes. The contrast of the two both foregrounded the compression of time as well as conveying a metaphoric layering of times.

Before cinema was invented, the Zoetrope and its many relatives moved images in a cycle or “loop”, rather than in a linear progression implying a narrative. The Zoetrope printed images on a strip of paper that was rotated in a drum, and the Mutoscope displayed images by flipping a row of cards in front of a peep hole.³² Installation artists use video loops to keep the same images projected for longer periods of time during the period of the exhibition without having to manually start them from the beginning. This type of representation of time, sometimes appropriately termed cyclic time is also apparent in ritual, most of which in essence is structured around bringing the past to the present for a better future. In *Water Feels* cyclic time was apparent in

³² David Borwell and Kristin Thompson, *Film Art: An Introduction*, Sixth Edition (New York, McGraw-Hill 2001) 32.

two ways. The beginning scene and the closing scene were almost identical in terms of lighting, the costume of the cast and the visibility of the symbolic 'moon'. The two scenes tied the beginning to the end and metaphorically represented a cycle. The second way cyclic time occurred in the narrative of *Water Feels* was in the way the past (ancient traditional ritual) was repeatedly brought to the present into the consciousness of the people living in contemporary times.

The time after the performance, the 'future' during the performance, was considered in the conceptualization of the production. In the final moments of the performance, performers spray-painted outlines of their shadows on the vertically erected white screen. Spray painting onto the screen was a transgression of the medium, and changed the function of the screen from a light catching contraption to a canvas for paint. As a result of the performers' outlining their shadows with paint, those final moments appeared to be 'frozen'. Time of course moved on and the painting that remained after the show acted as a kind of residue of the performance and a marker of a moment in time.

Image 7 was taken whilst the spray-painting took place. Image 8 is of the screen after the house lights came on.

Image 7



Image 8

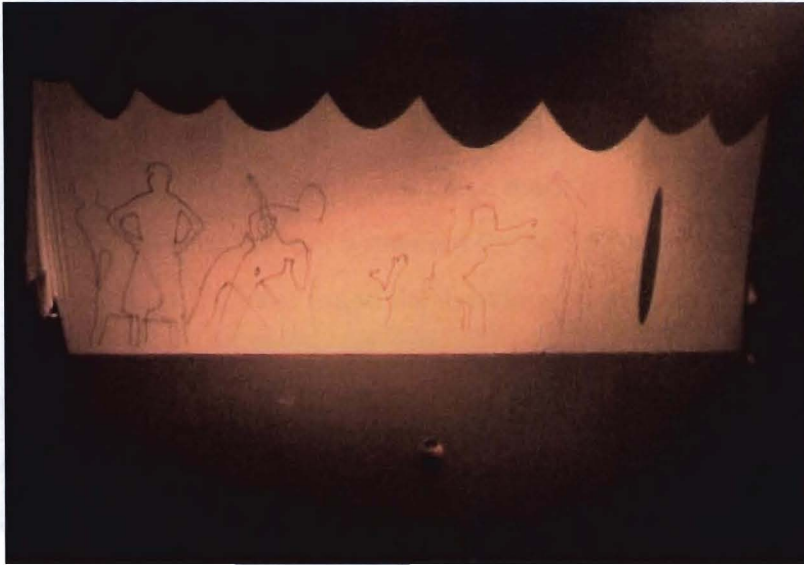

The transformation of the function of the screen was reminiscent of the use of masks that are carved for the purpose of ritual. The purpose of the mask is not entirely aesthetic. It also acts as a representation of an access or meeting point to another dimension, in traditional terms, the world of the ancestors. When the ceremony is over, the mask changes its function from a symbol of mediation to a sculpture, a piece of art that can be exhibited in museums (and many times not appropriately because it is exhibited out of context from its original function).

The vertically erected screen in the production *Water Feels* became an object of metaphorical mediation, because during the scene when the projected image beckoned the performer to walk through the hole that had been cut into the vertically erected screen, the projected image represented an altered state of consciousness, or a healer, or an ancestor. The hole was a metaphoric gateway to the altered state of consciousness or world of the “unseen”. In the narrative, this is followed by the coming of rain, a climactic moment in the performance and the outcome of the contact.

Similarly there was metaphorical mediation when after the moment of contact and the coming of rain, a representation of permanence (spray paint on vertically erected cloth) was added to the ephemeral moment (performance).

After the performance, when the house lights went on, it could be posited that the audience had some kind of a relationship with the images on the screen. They had witnessed the making of them and the circumstances of the transformation the screen underwent. But in the same way that a mask loses a great deal out of its context, so too someone who had not witnessed the performance who walked into the theatre afterwards, might have found the drawings empty and reduced.

The concept of time being important after the performance was further elaborated when all the performers after the curtain call and the house lights were on, crossed the stage line to distribute bottles of water to the audience. The crossing of the stage line symbolized a spilling over of the message of *Water Feels*, from the theatrical or fantastical narrative, into the real world.

Shooting, editing and presenting video for the live performance

The style of presenting video in *Water Feels* called for a different approach from shooting and then projecting for cinema, or that of broadcasting for television. The composition for cinema or television occurs in a single frame, with the rectangle of a television set or cinema screen. My own technique, in contrast, required the three separate frames to function as a single composition.

I shot similar and identical objects and people from different angles and projected them at the same time. I called this approach of presenting video “video cubism.” In futurism or cubism, multiple points of view or stages of motion are depicted in a single image in an attempt to represent the dynamism and complexity of human vision by imaging simultaneously from multiple perspectives.³³ From a distance all the projections lined up next to each other worked as a single frame. The video projection depicted in image 9 is an example of how “video cubism” worked in *Water Feels*.

³³ Cubism is an early twentieth-century art movement that was a part of the modern French avant-garde. Cubism began with a collaboration between Pablo Picasso and George Braque, who were both developing new ways of depicting space and objects. Marita Sturken and Lisa Cartwright, *Practices of looking: An Introduction to Visual Culture* (New York: Oxford University Press, 2001) 352.

Image 9



I used three separate video tracks in the editing programme Final Cut Pro for each perspective of the object or person that had been recorded on mini DV tape. Editing the footage in one sequence enabled me to synchronize the clips. When I needed to see what was occurring on the other video tracks I lowered the opacity level line graph in the clip and viewed the images superimposed on the canvas. Once the edit was complete, each video track was copied and pasted onto a separate sequence and burnt onto DVD. The soundtrack was burnt onto only one DVD.

I avoided developing an elaborate narrative in the projected images so that the video had 'spaces' within it for interaction with performance. The video provided hints that invited in and embellished the narrative performed by the performers. The moments of unexpected, direct interaction between video and performance created a tension which served the narrative.

An example of this occurred in the scene where the character that had been 'healed' during the Tswana/San traditional ritual dance walked through the hole in the vertically erected screen. The hole had been cut by one of the performers whose character was that of a healer. The hole was big enough for the audience to see her behind the erected cloth. At the same time part of her body cast a shadow on the screen. The image in the video projection was of a single red hand. The hand moved

from the top of the frame until the finger tips reached the shadow of the head of the performer. The hand appeared to be first pointing at her and then caressing her as she danced to the clapping hands of the cast behind the erected cloth. The metaphoric meaning was that the world that was represented by the video projection and the space behind it had made contact with that of the living in yet another, 'third' space which was available to the audience only as shadow.

Anticipation by the audience of not just how the narrative itself progressed but how the interaction of video and performance cohered or clashed became an important meeting of the movement and progression of both content and of form.

During the performance each of the three DVD players and projectors was operated by one person. The three operators placed a piece of board in front of the projector lenses to ensure no light escaped onto the vertically erected screen before the performance. Projectors project the logo of their maker's companies and the menu when they are on standby. The operators tried to press the play button on the DVD players at the same time. They then lifted the pieces of board at the same time so that the images played in the synchronized way in which they were edited in the Final Cut Pro.

Ideally the equipment that would have helped to smoothly fade in and out from black is a video mixer. A digital video synchronizer would have enabled the frames from each projector to adjust the timing to match one another so that they started exactly at the same time.

The composition of the video frames and the performers in the performance space had various effects. An asymmetric composition has a pull on one side and provides a tension or dynamic quality. In asymmetric composition the negative space becomes apparent and gives the illusion of space. Image 10 is an example of how asymmetric composition was used in *Water Feels*. In this scene the consciousness of the people is not yet united by the ritual and an imbalance is expressed through an asymmetric composition.

Image 10

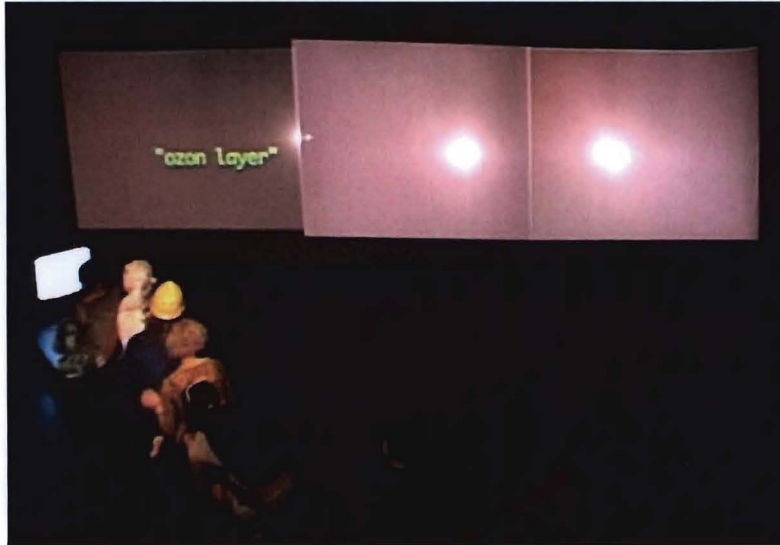

Image 11 is an example of a symmetric composition in *Water Feels*. This composition indicates balance, surety, stability and power³⁴. At this stage of the narrative a connection had been made with the experience of a collective consciousness and the symmetry of the composition helped to express that.

Image 11



³⁴ Anne Lynne Blom and Tarin Chaplin, 1982. *The Intimate Act of Choreography* (London: Pittsburgh, 1982) 38.

CONCLUSION

In this valuable exercise of reflecting on the making of *Water Feels*, three major questions emerged.

The first question was simply, ‘what was I presenting in *Water Feels*?’ Literally, I was presenting a semblance of a rain making ritual, but, through it, I was also presenting an instance in post-apartheid Southern Africa of the emergence of changing, new identities. A subsidiary question was, if identities were being redefined and were changing and becoming new, what were they before and what did they become after that? These questions were impossible to answer except to say that the ambiguity afforded by my “layering of time,” together with the ambiguity inherent in the interpretation of representation, suited very well the overall nebulosity of the internal processes of identity formation.

The second question was whether *Water Feels* should, as it was presented, be assessed by the authenticity of its representation? The answer here could be both yes and no. Yes, because the old African, Asian and European slave holding empires did exist; so too slavery in the Americas; so too colonialism; so too the Herero genocide; and so too were apartheid and its demise facts of history. The accompanying power-entrenching stereotypes were, in addition, facts of history too, and equally so the opposition to them, as exemplified in the Tswana and Xhosa proverb, ‘a human being is a human being because of other human beings’, that reciprocity is neither uncivilized, primitive, nor backward, but is an ethos that can go a long way towards healing the social wounds caused by brutal and rapacious regimes. In so far as *Water Feels* found narrative context in all of these, then its content was authentic. Yes again, with reference to the UNESCO definition of culture as having a ‘set of distinctive

spiritual, material, intellectual and emotional features of society or a social group', I used the example of Miles Davis's influence on hip hop, and located Miles Davis in an even older tradition of gospel and blues, arguing that the old lives on in new forms. Such an argument takes for granted that the old is in some measure authentic and constant and is in some measure identifiable in the new. No, because the very notion of change, of 'shedding skin and transforming shape', paradoxically impinges on authenticity. Certainly the representation of water and of the rainmaking ritual in *Water Feels* is not the ritual itself, nor would it be the ritual even if *Water Feels* had been a documentary or a photograph. Furthermore, layering time by creating illusions is a manipulation that speaks against authenticity even as it seeks to present it. Not least, the choices that I made, a Tswana / San ritual rather than a Christian baptismal one and the sequences that I decided upon, impinge on authenticity as well.

The third question arose from the recognition that *Water Feels* is a construct, and that whatever meaning it has was only one of several that are floating around in the region and abroad in performance, policy documents, social discourses and the like. Did *Water Feels* reflect the truth about contemporary southern Africa, the empirical facts of its history, as spoken of earlier? The answer was, yes, one truth amongst many others. Given this history, it follows that there are also many true ways of being a southern African, not just one. In relation to questions of representation and its forms, and who did it, how and when, the situation became very complex, pointing to the tenuousness of the very idea of 'truth,' unless we define it not as accuracy but as the kind of meaning that reaches significance in the context of other meanings.

These questions have been proffered as a result of the work and this explication and

will continue to inform my art-making process as will my continued work with mixed media. Coming from a background of video production, the mixing of media in *Water Feels* made it possible for me to explore conceptual relationships between media in a complex and personally enriching way. In the course of this exploration I discovered my own particular visual style of intensifying the screening of projected images by increasing projection surface and using multiple projections, and then by adding live performance.

The said conceptual relationships arose largely from the interplay of video and live performance. A highlight for me was that with the aid of various objects it was possible to create illusions in which the projected images seemed to transcend the limitations of the medium and became self-reflexive, thus seeming to be more than just the two dimensional properties that they actually were. Also rewarding for me were the points of connection with post colonial and post modern art and discourse that reflected the necessary ambiguity for portraying the emerging identities, attendant upon the historical changes that continue to affect the southern African region.

Most exhilarating for me was that I have begun to develop a visual metaphor for expressing the cultural transition that is taking place in the region, and have begun developing the metaphor for holding, in some measure, its complexity; that of 'layering time'. This layering was possible because of the video editing techniques that allowed me to map time in a two dimensional space and to manipulate it. The use of live performance helped to create a third dimension. And finally the re-representation of ritual with all its paradoxes and ambiguity facilitated the necessary transitions and discourses through and amongst past, present and future.

REFERENCES

- Barnouw, E. 1993. *Documentary: A history of the non-fiction film*. New York: Oxford University Press.
- Batten T.E. Amsterdam Jan/Jul/Aug 1996.[Online]. Available: <http://www.dma.nl/batten/what.htm>.
- Bhabha, H. 1994. *The Location of Culture*. London and New York: Routledge.
- Blom, L.A., Chaplin, L.T. 1982. *The Intimate Act Of Choreography*. London: Pittsburgh.
- Borwell, D., Thompson, K. 2001. *Film Art: An Introduction*. Sixth Edition. New York: McGraw-Hill.
- Cartwright, L., Sturken, M. 2001. *Practices of Looking: An Introduction to Visual Culture*. New York: Oxford University Press.
- Emoto M., 2004. *Hidden Messages in Water*. Transl. by David A. Thayne. Hillsboro, Oregon: Beyond Words Publishing, Inc.
- Davis, Miles. 1991. *Doo-Bop*. Warner Brothers.
- Erlewine, M., Bogdanov, V., Woodstra, C., Yanow, S. 1998. *All Music Guide to Jazz*. Third edition. Miller Freeman Books: San Francisco.
- Hall, S. 1997. *Representation: Cultural Representations and Signifying Practices*. London: Sage Publications.
- Magnet Theater. 2003. *Rain in a Dead Man's Footprint*. Jazzart Dance Theater. Directed by Mark Fleishman.

- Maswanganyi Collen. 2003. *Business Man*. Spier Collection.
- Mirzoeff, N. 2002. *The Visual Culture Reader*. Second Edition. New York: Routledge.
- Monti, N. 1987. *Africa Then: Photographs 1840-1918*. New York: Alfred A. Knopf.
- Ngugi, wa Thiong'o. 1965. *The River Between*. London: Heinemann.
- Oliver, R., Fage, J.D. 1988. *A Short History of Africa*. Sixth Edition. Harmondsworth: Penguin Books.
- Ortiz, F. 1942. Fernando Ortiz on Phases of Transculturation: Speech made at Club Atenas in Havana, December 12 1942. In Sierra J.A. History of Cuba.com [Online] Available: <http://www.historyofcuba.com/race/oritz-2.htm>
- Patterson, O. 1982. *Slavery and Social Death: A Comparative Study*. Cambridge. Mass. and London: Harvard University Press.
- Radio Botswana. "Go Tla Ga Baherero Mo Botswana" (The Coming of the Herero 1970 to Botswana). Filed as: 'Feature Programmes -1970 (Audiotape and Transcript)'.
University of Cape Town
- Rieser, M., Zap A. 2002. *New Screen Media: Cinema/ Art/ Narrative*. London: Bfi Publishing.
- Serote, M.W., 2000. *Hyenas*. South Africa : Vivlia
- Sparge, S.F., 1978. *Yoruba Photography: How the Yoruba See Themselves*. African Arts, xii

Weston, J.L. 2002. *From Ritual to Romance*. Tenth Edition. Project Gutenberg Online Reader. E-text #4090. [Online] Available:
www.infomotions.com/etexts/gutenberg/dirs/etext03/7trm10htm-395k (1920).

http://www.unesco.org/education/imld_2002/uneversal_decla.shtm.

<http://www.bbc.co.uk/1/hi/world/1887451.stm>

<http://en.wikipedia.org/wiki/Time>

BIBLIOGRAPHY

Birringer J. 2000. *Performance on the Edge: Transformations of Culture*. New Jersey: The Athlone Press.

Distiller N. and Steyn M. 2004. *Under Construction: 'Race' and Identity in South Africa Today*. Sandton: Heinemann Publishers (Pty) Ltd.

Hill L. and Paris H. 2001. *Guerilla Performance and Multimedia*. London: Continuum.

Lewis-Willims D. and Pearce D. 2004. *San Spirituality: Roots, Expressions & Social Consequences*. Cape Town: Doublestory Books.

Morgan D. 2005. *The Sacred Gaze: Religious Visual Culture in Theory and Practice*. Los Angeles: University of California Press.

Porter R.E. and Samovar L.A. 1985. *Intercultural Communication: A Reader*. Fourth Edition. Belmont: Wadsworth Publishing Company.

Steyn M. 2001. *Whiteness Just Isn't What It Used to Be: White Identity in a Changing South Africa*. Albany: State University of New York Press.

University of Cape Town
Faculty of Humanities

Title
LAYERING TIME: THE REPRESENTATION OF TRADITION IN
CONTEMPORARY MULTI MEDIA PERFORMANCE

Full Name: Moratiwa Molema
Student No.: MLMMOR001
Course: MFA Film and Television
Course Code:
Supervisor: Jay Pather
Due date:

1. I know that plagiarism is wrong. Plagiarism is to use another's work and to pretend that it is one's own.
2. I have used the Harvard convention for citation and referencing. Each significant contribution to and quotation in this essay from the work or works of other people has been acknowledged through citation and reference.
3. This essay is my own work.
4. I have not allowed and will not allow anyone to copy my work with the intention of passing it off as his or her own work.
5. I have done the word processing and formatting of this assignment myself. I understand that the correct formatting is part of the mark for this assignment and that it is therefore wrong for another person to do it for me.

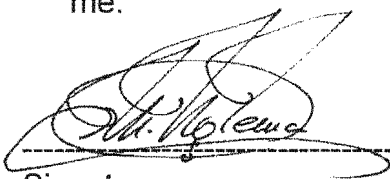

Signature

14-11-2008

Date