



AN INVESTIGATION INTO THE PERFORMANCE OF FULL BRT AND PARTIAL BUS PRIORITY STRATEGIES ON ARTERIALS

Academic Supervisor: Assoc. Prof Marianne Vanderschuren



**A Master of Science in.
Engineering (MSc.Eng)
Dissertation**

Friedrich Chitauka
MSc. Eng Candidate

The copyright of this thesis vests in the author. No quotation from it or information derived from it is to be published without full acknowledgement of the source. The thesis is to be used for private study or non-commercial research purposes only.

Published by the University of Cape Town (UCT) in terms of the non-exclusive license granted to UCT by the author.

An Investigation into the Performance of Full BRT and Partial Bus Priority Strategies on Arterials By
Microsimulation Modelling In A South African Context

By

Friedrich Chizhyindiswe Chitauka

A dissertation

submitted in partial fulfillment of the
requirements for the degree of:

Master of Science in Engineering (Transport Studies)

University of Cape Town

2014 on the 20th of December

Academic Supervisor:

Associate Professor Marianne Vanderschuren

Program Authorised to Offer Degree:

Transport Studies

(Department of Civil Engineering)

Acknowledgements

This study was made possible through the generous funding of the Volvo Research Foundation (VREF) under the auspice of the African Centre of Excellence in Public and Non-Motorised Transport (ACET).

I would like to express my heartfelt gratitude to Assoc. Professor Marianne Vanderschuren of the Centre of Transport Studies at University of Cape Town. Prof's guidance, insights and knowledge as my supervisor were invaluable. Furthermore, I would also like to thank Mr Francois Meyer, General Manager at Golden Arrow Bus Services (GABS) for opening his doors and sharing their costing data and Mr Davie Patience of the CoCT Traffic Management Centre for the loop data.

All members of the Centre of Transport Studies (UCT) including my fellow postgraduate students, for the ideas shared during our informal discussions.

Plagiarism Declaration:

1. I know that plagiarism is wrong. Plagiarism is to use another's work and to pretend that it is one's own.
2. I have used the ...Harvard..... convention for citation and referencing. Each significant contribution to, and quotation in, this essay/report/project from the work, or works, of other people has been acknowledged through citation and reference.
3. This essay/report/project is my own work. I have not used the material in this essay/report/project in any of my other essays/reports/projects.
4. I have not allowed, and will not allow, anyone to copy my work with the intention of passing it off as his or her own work.
5. I have included internet article references used for this assignment.

Signature:

Signed by candidate

Date: 05/02/2015

Table of Contents

Acknowledgements	1-2
Plagiarism Declaration:	1-3
1 Executive Summary	1-11
2 Introduction.....	2-15
2.1 Background to Investigation.....	2-15
2.2 Problem Statement: Relevance of Research	2-16
2.3 Objectives of Research	2-18
2.4 Limitation and Scope of Investigation.....	2-19
2.5 Research Structure	2-19
2.6 Case Study: Klipfontein-Lansdowne Corridor	2-20
2.7 Development and Flow	2-24
2.8 Research Mind Map.....	2-26
3 Literature Review.....	3-27
3.1 The Transport Demand	3-27
3.2 The Transport Supply	3-28
3.3 Characteristics of Public Transport	3-28
3.4 Categorisations of Public Transport	3-28
3.4.1 Capacity.....	3-29
3.4.2 RoW.....	3-29
3.4.3 Public Transport Technologies.....	3-29
3.4.4 Rail Based Systems	3-29
3.4.5 Light Rail Transit (LRT)	3-30
3.4.6 Newer Rail Technologies	3-30
3.4.7 Bus Based Systems.....	3-31
3.4.8 Public Transport in South Africa’s Urban Areas: Status Quo.....	3-31
3.5 Context: Why Improvements In South Africa’s PT Are Needed?	3-33
3.6 Transport Policy and Bus Priority	3-34
3.7 South Africa’s Public Transport Policy.....	3-37
3.8 Public Transport and Traffic Congestion	3-38
3.9 Application of Priority to Public Bus	3-39
3.10 Types of Bus Priority.....	3-41

3.10.1	Operational Priority Measure (OPM)	3-41
3.10.2	Infrastructural Priority Measures	3-42
3.11	Measuring the Performance of Bus Systems	3-43
3.12	Factors of BRT Performance	3-43
3.12.1	Capacity	3-44
3.12.2	Reliability	3-44
3.12.3	Speed	3-45
3.12.4	Safety: Road Safety and Security	3-45
3.12.5	Resource Utilisation	3-46
3.12.6	Public Perception	3-46
3.13	BRT/Transport	3-47
3.13.1	Elements of a BRT System	3-48
3.13.2	Running Way and Bus Priority	3-48
3.13.3	Stations	3-50
3.13.4	Vehicles	3-51
3.13.5	Fare Collection	3-51
3.13.6	Operating Plans and Control Systems	3-52
3.13.7	Speed	3-52
3.13.8	Passenger Information Systems	3-53
3.13.9	Integrated Rapid Public Transit Networks (IRPTN)	3-53
3.13.10	A Comparison of BRT Systems and Operations	3-55
3.14	Public Transport Systems and Infrastructure in South Africa	3-57
3.14.1	Implementation of BRT in South Africa	3-57
3.14.2	Inclusion of BRT Elements in South African BRT Systems	3-59
3.15	Public Transport Modes and Infrastructure	3-60
3.15.1	Placement of Bus Priority Measures	3-60
3.15.2	Bus Ways	3-61
3.15.3	Bus Lanes	3-62
3.15.4	Intermittent Lanes	3-62
3.15.5	Dedicated Bus Lane (DBL)	3-63
3.15.6	Bus-Only Street or Bus Malls	3-65
3.15.7	Special Road Geometry Considerations	3-67
3.15.8	Shoulder Running Lanes	3-67
3.15.9	Queue Jump Lanes	3-68

3.15.10	Bus Signal Priority (BSP).....	3-69
3.15.11	Pre-signal	3-70
3.15.12	Brief Overview of Traffic Signal Plan Design	3-71
3.15.13	Application of BSP	3-72
3.15.14	Passive Priority (PP).....	3-72
3.15.15	Active Priority (AP).....	3-72
3.15.16	Applicability of Transport Priority Schemes to South African Urban Areas.....	3-74
3.15.17	Bus By-Pass Shoulder.....	3-74
3.15.18	Pre-emption.....	3-75
3.15.19	Signal Coordination	3-75
3.16	Financial Considerations in Public Bus Systems.....	3-77
3.16.1	Generalised Cost of Travel.....	3-77
3.16.2	BRT Cost Framework	3-78
3.16.3	Current Cost Framework Based on Cape Town Data	3-80
3.16.4	Time Value in Cape Town: “the cost of delays”.....	3-80
3.16.5	Synthesis of Literature Review	3-81
4	Methodology.....	4-83
4.1	Modelling Traffic Systems	4-83
4.2	Fundamental Theories of Traffic Modelling	4-83
4.3	The Classic Transport Model.....	4-84
4.4	Mathematical Theory Underlying Microsimulation	4-84
4.5	Lane Changing and Gap Acceptance.....	4-85
4.5.1	Queuing and Bottlenecks.....	4-87
4.6	Analytical Methods.....	4-88
4.7	Microsimulation of Traffic Systems with PARAMICS	4-88
4.7.1	Steps of Execution:.....	4-89
4.8	Microsimulation Modelling.....	4-92
4.8.1	Modelling and Microsimulation of Public Transport Systems	4-92
4.9	Results Analysis Methodology	4-94
5	Results and Analysis	5-97
5.1	The Modelled Scenarios	5-97
5.2	Model Set-Up.....	5-97
5.2.1	(Origin-Destination) OD Matrix Development.....	5-97
5.2.2	Scenario Development Summary	5-98

5.3	Baseline 2012/13 Scenario	5-100
5.4	Bus Mini-bus Taxi Lane Scenario	5-101
5.5	Bus Queue Jumper Lanes (BQJ) Scenario.....	5-102
5.6	Bus Median with BSP Scenario.....	5-104
5.7	Bus Median without BSP.....	5-105
5.8	Bus Kerbside without BSP	5-106
5.9	Bus Kerbside with BSP	5-107
5.10	Results Summary.....	5-108
5.11	Delay Analysis.....	5-110
5.12	Statistical Analysis of Results: ANOVA.....	5-111
6	Conclusions: Consolidation of Findings	6-112
6.1	What is the current extent of traffic congestion on South African urban corridors? .i.e. assess the performance public transport modes in the current (2012/13) traffic condition especially during daily travel peak periods?	6-113
6.2	How does bus transit performance under partial priority compare to implementation of full priority as is the case in full BRT Systems?.....	6-113
6.2.1	To what extent can bus priority measures improve the bus delay?.....	6-114
6.3	What are the impacts of corridor based priority measures on other modes?.....	6-114
6.4	What is the most effective combination of bus priority measures?.....	6-115
6.5	Recommendations.....	6-116
7	Bibliography.....	7-118
8	Appendix.....	8-0

Table of Figures

Figure 2-1 The Different Phases of MyCiti (Cape Town's IRPTN) Implementation	2-21
Figure 2-2 A Screenshot of The Study Area Road Network As Coded Into The PARAMICS Model. <i>Klipfontein Road</i> (Red line)	2-21
Figure 2-3 A Picture Of The Study Area Highlighting Klipfontein Rd (M18) in (blue) and some the alternative Roads Included In The Model Network (Red)(<i>Google Maps, 2015</i>).....	2-23
Figure 2-4 Flow Chart of Planned Execution of Study	2-24
Figure 2-5 Study Research Structure.....	2-25
Figure 3-1 Modal Split of South Africa's Urban Areas	3-31
Figure 3-2 Minibuses in Cape Town.....	3-32
Figure 3-3 Typical Experience of Public Transport for most Commuters in South Africa	3-32
Figure 3-4 A Typical High-floor Public Bus in Cape Town	3-33
Figure 3-5 Policy Affects All Facets Of A Transport System	3-35
Figure 3-6 Objective-Led Strategy/ Policy Formulation Structure	3-36
Figure 3-7 The Evolution Of South Africa's Policy Framework From 1996 To Present (Walters, 2013) 3-37	
Figure 3-8 Illustration Of The Link Between Income Level And Transport Mode Choice.....	3-39
Figure 3-9 showing some basic elements of a South African BRT System.....	3-40
Figure 3-10 An Example a Bus Priority Signal Installation	
Source: (http://www.th.gov.bc.ca/popular-topics/images/faqimages/bus_priority.jpg)	3-41
Figure 3-11 barrier separated High Occupancy Vehicle (HOV) Lane	3-42
Figure 3-12 Typical BRT Running Cost(Excluding Right-Of-Way)(Lee et al., 2007)	3-42
Figure 3-13 A Conceptual Design Showing the Main elements of a BRT System	
Source :(http://www.city-data.com/forum/urban-planning/1216372-will-any-msa-have-better-brt.html)	3-48
Figure 3-14 Integration of Rail (Tram) and Bus Services in Bern, Switzerland	
Source: (http://citytransport.info/Nondhtml.htm).....	3-54
Figure 3-15 A section of Cape Town's BRT along the R27 during construction (CoCT,2012)	3-59
Figure 3-16 Element of a Road Cross-section (CSIR, 2005)	3-61
Figure 3-17 An example of a Bus Lane as used In London, England.	3-62
Figure 3-18 illustration of a Peak Direction Intermittent Bus Lane	3-63
Figure 3-19 Median Busway Placement.....	3-64
Figure 3-20 Curb side Bus way Placement	3-64
Figure 3-21 the Bus-Only portion of the Cape Town IRT system	3-65
Figure 3-22 An Example of A Bus Mall And Related Signage	
Source:(British Department of Enviroment Transport Government and Regions, 2001).....	3-66
Figure 3-23 Some Typical Bus Street/Mall Designs(Barker, Alvarez, Barnes, et al., 2003b).....	3-66
Figure 3-24 BBS And Road Marking Along Washington State DOT SR-522(Lee et al., 2006)	3-67
Figure 3-25 Typical Queue Jump Lane Designs	3-68
Figure 3-26 An Example Of An Execution Of A Queue Jump Lane And BSP Phases.....	3-69

Figure 3-32 Non-Priority Control Pre-Signal General Layout.....	3-70
Figure 3-33 A pre-signal in use along the R27 corridor of MyCiti Phase 1	3-71
Figure 3-27 BSP Concept Pie-graph	3-72
Figure 3-28 BSP Green Extension and Red Truncation Concept	3-73
Figure 3-29 Lansdowne Road Shoulder near Jan Smuts Road, <i>Cape Town</i> intersection (courtesy of Google Maps) and a BBS in Washington State, <i>USA</i> (Lee et al., 2006).....	3-74
Figure 3-30 Signal Progression	3-75
Figure 3-31 Klipfontein Road Corridor (near Athlone Stadium).....	3-76
Figure 3-34 Percentage Costs of key BRT Elements as calculated from the MyCiti Business Report .	3-79
Figure 4-1 Scales of Traffic Modelling and Transport Planning Horizons (Vanderschuren, 2006).....	4-83
Figure 4-2 an illustration of lane changing behaviour terms.....	4-85
Figure 4-3 Gap Acceptance-Rejection Time Vs. to the Opposing Movement Especially at Intersections (Akçelik, 2011).....	4-86
Figure 4-4 An Idealisation of a Queue Formation at a Road Intersection (Saito ,2004).....	4-87
Figure 4-5 A Screenshot of an Intersection Geometry As Coded Into The Model.....	4-92
Figure 4-6 Effect of Station Spacing on Average Speed of Bus Service (Lee et al., 2007).....	4-94
Figure 5-1 Baseline Scenario plot of Bus vs General Traffic Speed.....	5-100
Figure 5-2 Bus Mini-bus Taxi Lane Scenario plot of Bus Vs General Traffic Speed	5-101
Figure 5-3 Bus Queue Jumper Lanes (BQJ) Scenario plot of Bus Vs General Traffic Speed.....	5-102
Figure 5-4 Bus Median with BSP Scenario plot of Bus Vs General Traffic Speed.....	5-104
Figure 5-5 Bus Median without BSP Scenario plot of Bus Vs General Traffic Speed.....	5-105
Figure 5-6 Bus kerbside without BSP Scenario plot of Bus Vs General Traffic Speed	5-106
Figure 5-7 Bus kerbside with BSP Scenario plot of Bus Vs General Traffic Speed.....	5-107
Figure 5-8 All Scenarios Bus Mean Speed Comparative Plot	5-108
Figure 5-9All Scenarios General Traffic Mean Speed Comparative Plot.....	5-109

Table of Equations

Equation (3-1)	3-44
Equation (3-2)	3-44
Equation (3-3)	3-45
Equation 3-4	3-45
Equation 3-5	3-46
Equation 3-6	3-77
Equation 4-1	4-85

1 Executive Summary

Rapid urbanisation is a global problem affecting most developing and intermediate countries. As the world's urban population is set to double by the year 2050, growth in urban infrastructure and services is needed but is generally lagging behind this exponential growth, especially in most African countries. It is a reality that calls for smart responses. This implies that current resources need to be used efficiently to enable them to cater for the needs of an ever increasing urban population. Smart Transport is an innovative response to the urgent mobility and accessibility needs of urban inhabitants. Bus Rapid Transit (BRT) and bus priority measures are examples of smart transport.

Research into High Level of Service Bus Systems (HLSB) or more commonly known as BRT in South African settings; has shown that they can successfully improve urban mobility while simultaneously reducing congestion, energy consumption, vehicular emissions and increase transit efficiencies. BRT is defined as a rubber-tired form of rapid transit that combines stations, vehicles, services, running ways, and ITS elements into an integrated system with a strong image and identity (Barker, Alvarez, Barnes, et al., 2003). However, the relatively high capital and operating costs of full specification/feature BRT systems are prohibitive to many local authorities. In many cities where they have already been implemented, this service is often subsidised. Furthermore, the road space is a limiting factor, as many of the areas that BRT systems need to extend into, simply cannot accommodate conventional traffic mitigation strategies such as road widening or reservation of median lanes for BRT infrastructure.

In the long term, BRT has been selected as the preferred model for mass urban transit by government i.e. all of South Africa's major centres are in the process of implementing BRT systems. However, there is wide range of individual bus priority measures such as Bus Signal Priority (BSP) which have been used to improve public bus performance on urban corridors around the world. An opportunity exists to find alternative ways to extract maximum benefits of full specification/feature BRT. Hence the fundamental question this thesis will seek to answer is: *Is it possible to reap the performance benefits of a full specification BRT system or full bus priority by implementation of partial Bus Priority Schemes at strategic locations along transit routes?*

Literature reviewed shows that; the full-feature BRT model in South Africa (SA) was adopted without being subjected to a process of due diligence and objective evaluation at the time. Enhanced bus systems that do not exhibit all the prescribed features of a full-feature BRT are dismissed as "BRT-lite" by proponents of the full-feature BRT model such as the Institute for Transportation and Development Policy (ITDP). The high levels of poverty among users, poor urban spatial form and financially constrained local authorities has brought the appropriateness of full-feature BRT for along SA's urban arterials into question.

This roll-out of these full schemes has drawn criticism from institutions such as the World Bank who argue that the challenge in improving quality public transportation in SA lies in its access and affordability (Wood, 2014). This criticism is in light of the fact that Lagos BRT which is widely categorised as BRT-lite has demonstrated that improvements to public bus performance can be achieved in constrained African urban centres with less infrastructure and cheaper cost. Similarly, many North American cities have improved the performance of their public bus operations by using combinations of bus priority measures which are deemed most relevant for their local contexts rather than implementing full-feature BRT systems.

Research Objectives

The primary aim of this research is determine the effectiveness of alternative or partial bus priority measures compared to the baseline scenario and full priority. The study area chosen is Klipfontein road in Cape Town (CT). In order, to achieve these aims the following objectives were set:

- Review literature and understand how partial and full /string priority schemes are being used around the world.
- Establish baseline scenario .i.e. representative of the current situation on the ground.
- Test a set of alternative scenarios .i.e. replicating strong priority measures like full-feature BRTs configurations, Bus Signal priority and Bus Queue Jumpers especially at bottlenecks.
- Compare alternative/partial priority schemes compared to full priority case and baseline scenario.
- Determine extent of improvement in speed and reduction in delays.
- Make recommendation regarding application of alternative bus priority measures.

In order to achieve the above objectives the following research questions were formulated and answered:

1. What is the current extent of traffic congestion on South African urban corridors? i.e. assess the performance public transport modes in the current (2012/13) traffic condition especially during daily travel peak periods?
2. How does bus transit performance under partial priority compare to implementation of full priority as is the case in full BRT Systems?
3. To what extent can bus priority measures improve the bus delay?
4. What are the impacts of bus priority measures on other modes?
5. What is the most effective combination of bus priority measures?

Methodology

A set of quantitative methods was selected as the research approach to achieve the envisaged research outcomes. The main steps are below:

1. Data collection: mainly signal timings and traffic counts to get an understanding of the current operation at three major intersections.
2. A microsimulation model was set-up based on-site observations of traffic flows and signal timings recorded on visits.
3. Validation of initial results .i.e. travel times; by driving along corridor during morning peak.
4. Statistical analysis and comparison of results from respective scenarios. A t-test was conducted on generated results at a 0.05% level of significance.

5. Presentation of results and analysis
6. Conclusions were drawn and recommendations made based on the results obtained.

Results Summary

By using a computerised microsimulation package called PARAMICS (a commercial software package) a number of suitable transit priority measures and schemes were modelled based on a proposed transit corridor in Cape Town (CT). The outputs of a validated model indicate that applying alternative transit priority measure like Bus Signal Priority (BSP) can produce Levels of Service (LOS) for a bus which is comparable to full specification BRT systems. The results shown were tested at $\alpha = 0.05$ level of significance, they show that travel delay in buses was reduced by 27% to 32% while bus speeds improved by 50% to 76%.

Recommendations

Based on the results the following recommendations were made:

- Local transport authorities must first set performance targets for public buses per corridor and then select the most cost-effective way or mode configurations that achieve the set targets.
- Partial bus priority schemes must be considered and implemented as alternative to full feature BRT system. Hence, it is hoped that policymakers evaluate different priorities objectively and with relevance to the required outcomes of a given bus service, rather than simply replicating model systems.
- Establish a mode choice framework for selecting the most appropriate mode for a given corridor and demand pattern.
- Transport researchers and practitioners must formulate a spatial-mode suitability index which will indicate the suitability of major arterials in cities; relative to a given set of bus priority measures. The government and local transport authorities should work to improve and develop modelling skills in South Africa as it is a tool used in improving the quality of transport.
- Municipalities and local authorities must collect data relating to the performance of public transport modes more consistently. This will help assess improvements and highlight areas that need urgent attention .i.e. if you cannot measure it, you cannot fix it.

Future Research

The constraints of time and financing limited the scope of this research. However, it touched on a wide range of key issues concerning bus performance improvements and approaches. Two suggestions for future research in this area emerged. Firstly, to build on the findings of this study by conducting a detailed cost-benefit analysis on alternative bus priority measures vs. full-feature BRT measures. Secondly, investigate the broader impacts of turning arterials into high capacity public transport corridors .i.e. accident rates, vehicle emissions, land values and road infrastructure performance in South Africa.

Concluding Remark

The roll-out of full-feature BRT systems is being slowed by negotiations over formalisation of paratransit operators on routes, funding and the financial sustainability of these schemes. All BRT systems in SA are

currently operating and being constructed under subsidy from the national government. It is clear that navigating the political, socio-economic and spatial disparities that are unique to SA will take time. However, the implementation of alternative bus priority measures along transit corridors or at known bottlenecks along arterial offers means "quick wins" can be realized in terms of improving bus operations. The sustainability of enhanced bus services; depends on ensuring the benefits derived from implemented bus priority measure are proportional to their cost and socio-economic context. They also can be later integrated into full-feature BRT networks along the respective corridors if necessary.

2 . Introduction

2.1 Background to Investigation

This research dissertation describes the results, methods and theoretical base used to investigate the performance of different public transport priority measures for buses with high LOS in a South African context. This represents an application of Intelligent Transport Systems (ITS) to public transit. Microsimulation in the PARAMICS computer package was used to assess the performance of a range of public transportation priority schemes.

Transport systems serve as stimulators and enablers of economic growth and social development. Unfortunately, in most developing and intermediate countries their transport networks are unable to effectively handle the volumes of freight and people using them. South Africa's urban areas are faced with the effects of rapid urbanisation, inadequate municipal infrastructure and the historical legacy of racially segregated urban planning of the apartheid era.

In response to these developmental challenges, municipal authorities, such as the City of Cape Town (CoCT), among others have initiated public transport programs to address these inadequacies. The phased roll-out of Bus Rapid Transit (BRT) across six South Africa urban centres (at time of publication) namely: Johannesburg, Cape Town, Nelson Mandela Metropolitan, Durban, Tshwane and Rustenburg; represent active steps towards government's vision to provide high quality, sustainable and uncongested mobility in liveable cities and districts.

The basis of the next generation or "new wave" of public transport provision are Integrated Rapid Public Transport Networks [IRPTN](Department of Transport, 2007). IRPTNs are improved public transport networks which include physical and operational components that enable them to have higher capacity, universal access, good public perception and better performance than the existing transport system.

It can be seen that the South African government provides a generic template for providing public transportation in the country. The objectives set out in the Public Transport Strategy (PTS) (2004-2020) and the National Land Transport Act (NLTA) of 2009, closely correlate to the deliverables of a full specification BRT system.

In view of the current trends, most municipal authorities have translated this legislation by selecting bus based systems to form the core of the PT systems and with the aim of integrating them with other auxiliary or complementing modes such as rail, non-motorised transport (NMT), cycling and to a lesser degree private car. The only notable deviation from this model was the investment in the construction of the Gautrain Rapid Rail Link between Johannesburg and Pretoria.

According to the NLTA 2009; the responsibility of operating the PT systems is delegated to the municipal authorities. This implies that the cost of the operations is the primary responsibility of the Municipal Authorities (MA), despite assistance from the provincial and national for initial capital and

subsidy. However, the financial self-sufficiency of a PT is critical to ensuring its long term sustainability and immunity to the political interference (Wright and Fjellstrom 2003).

Therefore there is an opportunity exists to investigate alternative ways of getting the benefits of full specification BRT at lower cost and even shorter implementation time-frames (quick-win scenarios) and determining the most effective combination of public transport priority in a South African context. The implementation of partial public transport measures (PPTM) in addition to network wide improvements to PT infrastructure like stations, serves as an alternative to full priority schemes as is presently preferred in South Africa.

▪

2.2 Problem Statement: Relevance of Research

The world's cities are under threat from the negative effects of rapid urbanisation and population growth. This situation was worsened by the lack of adequate infrastructure, including; water, sanitation, housing and transport systems, to cater to the increasing demands on these already constrained facilities.

South Africa is no exception to these global trends and the unique challenges and opportunities they present. The rapid urbanisation rates and increasing motorisation levels ,which can be linked to a general trend of economic growth in South Africa's major urban areas ,has resulted in increasing travel delays and deterioration in the quality of intra-city travel.

The efforts to increase transport capacity has generally focussed on road expansions or widening .e.g. the Gauteng Freeway Improvement Project (GFIP) ,while overlooking ways to extract maximum use of existing road infrastructure. Clearly roads expansion, in view of continually increasing traffic levels, is unsustainable, costly and in some cases, impractical.

Bus Rapid Transit (BRT) has emerged as a solution to the urban mobility challenges in South Africa, it is now enshrined in the national PT policy (Department of Transport), 2007). According to the *TCRP Report 90(2003)*; *BRT is defined as a rubber-tired form of rapid transit that combines stations, vehicles, services, running ways, and ITS elements into an integrated system with a strong image and identity.* Therefore, full BRT is a system that uses all the key components of an ideal BRT system as defined above while partial BRT only uses specific elements.

The hosting of the 2010 FIFA World Cup™, in South Africa accelerated the implementation of BRT systems. Hence, it was driven by the impetus to meet “host nation” public transport requirements. The suitability and adaptability to various South African conditions of the full specification BRT model ,as stipulated by the ITDP in the BRT Planning Guide (Wright and Hook 2007) ,has not been exhaustively questioned through academic enquiry.

The urban mobility improvement by ,and benefits of BRT systems in a number of cities in Europe, North America and Latin America, most popularly Curitiba, Brazil are well documented (Hidalgo and Carrigan 2010; Wright and Hook 2007; Kerkhof and Soulas 2011). The documented case studies mostly serve to highlight and compare the benefits of similar full specification BRT system. Despite the fact that; they are exponentially cheaper and faster to implement, they are still not fully financially feasible options for

most developing and middle income countries i.e. they cannot operate without some degree of subsidy (Gauthier and Weinstock 2010).

This paper will use microsimulation to objectively evaluate the difference in performance between full BRT priority measures and partial priority measures. Furthermore, it will seek to quantify the impacts on non-priority traffic and the time and benefits of each type of scheme. Through a review of literature a number of key performance indicators, such as speed travel duration and travel delay have been identified to determine the effects caused by implementing either full or partial BRT measures.

It is clear that the current organisation and operation of South Africa's urban commuter transport systems is unsustainable from a social, economic and environmental perspective. Yet, it remains that effective solutions to its transport challenges must be sought and modifications must be made to available technologies to ensure that, they are adapted to the local context and that maximum PT system efficiency is attained.

2.3 Objectives of Research

The primary objective of this research is to investigate and compare the effectiveness of different public bus priority measures under South African conditions. Academic literature and research about ITS measures on this matter is limited. The research will be done from two perspectives, namely the user and operators.

Selecting key performance indicators (KPIs) will reflect the user's experience and generally accepted measures of effectiveness (MOEs). A selection of KPIs for user experience includes:

- Travel Time
- Travel Delay
- Travel Speed

This study will focus on speed and delay. There are other indicators such as comfort, emissions and safety, which are out of the scope of this investigation and cannot be accurately deduced from the outputs generated. The KPIs used are relevant to determining the level of service (LOS) of the PT schemes, as total travel time is a basic factor in the perceived utility of a PT system by users.

A set of research questions, were formulated. They enabled the author to determine the aforementioned parameters and assess them within the framework of the guiding hypothesis. This will allow the main research question to be answered. The following are the main research questions that were formulated:

6. What is the current extent of traffic congestion on South African urban corridors? i.e. assess the performance public transport modes in the current (2012/13) traffic condition especially during daily travel peak periods?
7. How does bus transit performance under partial priority compare to implementation of full priority as is the case in full BRT Systems?
8. To what extent can bus priority measures improve the bus delay?
9. What are the impacts of bus priority measures on other modes?
10. What is the most effective combination of bus priority measures?

The aim of this research is to quantify the extent of the benefits and effects of applying bus priority measures in a typical South African urban corridor. There is well documented work detailing the policy implications, political and socio-economic impacts of implementation of initial phases of full specification BRT systems in two of South Africa is metropolitan areas i.e. Johannesburg and Cape Town respectively.

However, there is very limited independent or peer reviewed information if any, concerning the degree of improvement or benefit achievable by bus priority schemes in the framework of the aforementioned KPIs in percentage or real terms for South African conditions. At time of publication, review of literature failed to yield a prior systematic investigation of performance of partial priority measures compared to strong or full priority measures on the specific study area.

Hence, the results and consequent analysis emanating from this study, will seek to fill this knowledge gap. It is hoped that this can help inform future decision-makers as to the most cost-effective ways to improve the LOS for public transit.

2.4 Limitation and Scope of Investigation

The geographic scope of this investigation was the given study area i.e. Klipfontein and Lansdowne Corridor in the general vicinity of Athlone area of Cape Town, South Africa. This area was selected because both have long been earmarked by the City of Cape Town Municipality (CoCT) for roll-out of PT LOS improvement initiatives.

Intelligent Transport Systems (ITS) are widely varied in their types and applications but this investigation will focus on ITS measures relating to Vehicle Actuated Traffic Controllers and Road Space or RoW Management Strategies. Most of South Africa's urban areas have used Advanced Traffic Controllers (ATCs) technologies such as Split Cycle Optimisation Technique (SCOOTs) for long time i.e. since the late 1960s (Vanderschuren, 2006). But the literature failed to yield information for use of ATC for the purpose of improving urban PT performance. Further investigation into the matter with practitioners at the CoCT revealed that considerable numbers of installed actuators i.e. inductive loops are not functional due to theft and vandalism (Patience (Traffic Management Centre) 2012).

The author is aware that some degree of BSP is currently in use at particular locations along Cape Town's first BRT corridor along the R27 (Civic Centre to Atlantis via Table View). However information about the exact benefits and improvements, due to the implementation of these PT phases, is unavailable.

The simulation model set-up and subsequent analysis of results will focus primarily on motor vehicle (all car types) and public transport modes in the form of buses and taxis. The movement of pedestrians will get limited consideration in a few scenarios particularly at intersections to evaluate the friction caused. The results relating to key performance indicators are to be generated in a commercial traffic simulation software suite called PARAMICS.

It is critical to balance the need for a detailed model without making the set-up complicated. The other determining factor was unavailability of calibration data which required physical data collection on-site, hence the study area size selected was adequate to obtain results and observe the parameters of interest to answer the main hypothesis. A more detailed treatment of these related issues that are beyond the scope of this investigation forms the basis of possible future work.

2.5 Research Structure

Based on a review of similar studies in the transport field; the investigation was executed in 12 sequential steps, although some were carried out concurrently. The order of the research was as follows:

1. Detailed investigation into the operation and design of public transport systems: This included taking a course in Intermodal Public Transport Planning and Economics offered by the Centre for Transport Studies at the University of Cape Town.

2. Study and survey of application of ITS in road transport management around the world: Literature, especially design manuals of various cities, was reviewed to understand the situations where ITS measures such as ATC are used.
3. Identification of Public Transport Priority suitability for use in South Africa: This step required the selection of PT priority measures that can be integrated with existing systems without drastic overhaul of current infrastructure.
4. Familiarization with selected traffic simulation software namely PARAMICS: The author spent time designing simple networks to gain an understanding and intuition for the software as later some scenarios required ingenious application in-built functions to simulate local conditions.
5. Research about selected case study area: This information was obtained from the City's Integrated Development Plan (IDP). It consists of areas with a population of about 70,000 people served/bounded by two main arterials, namely Klipfontein and Lansdowne Roads.
6. Collection of data from study Area: This included organising visits to some key intersections within the study area to do traffic counts and assess signal timings.
7. Translation of data into input files for simulation model: The collected data from various sources had to translate into input files that the software could read when coded.
8. Development of base scenario: By consulting with experienced transport professionals and supervisor, a base scenario (Status Quo) was generated to simulate current (2012/13) conditions as accurately as possible especially along the main roads in the study area.
9. Model Calibration: Data sourced from the CoCT's Traffic Management Centre which oversees the ITS matters of the city and literature was used in this step.
10. Scenario Development: A number of scenarios relevant to South African urban mobility had to be developed.
11. Analysis of Results: The outputs used to extract information and insights about the current traffic situation and impact of feasible changes.
12. Reporting and Summary of Findings.

2.6 Case Study: Klipfontein-Lansdowne Corridor

The study area selected is located in the Cape Town Metropolitan Area. The main reasons it was selected are listed below:

- The two main arterials being investigated currently experience high levels of congestion i.e. some sections are jammed during peak hour. The dynamics of operating enhanced or ordinary bus services under highly congested conditions are not fully understood despite their wide-spread occurrence in many of South Africa's urban areas.

- The Klipfontein and Lansdowne Road Corridors are earmarked to be an integral part of the continued expansion of the CoCT's IRPTN, as Figure 2-1 below shows they fall under proposed Phase 2 of implementation. However, the simulation outputs will focus on the Klipfontein corridor. At time of publication, the CoCT was initiating Phase 1B after which Phase 2 is expected to follow.



Figure 2-1 The Different Phases of MyCiti (Cape Town's IRPTN) Implementation



Figure 2-2 A Screenshot of The Study Area Road Network As Coded Into The PARAMICS Model. *Klipfontein Road* (Red line)

It is noted that the study area has been subject to a number of interventions to improve performance of public transport modes, particularly existing bus services. These measures include marking of bus lanes. However, observations during site visits to the area by the author revealed that most of the measures were visibly ineffective, as motorists do not comply with them.

- The area has relatively high travel demand given the settlement patterns and prevailing LOS observed.
- There is limited space in most corridor sections for widening of roads to accommodate conventional full specification BRT (especially median lane placement) and to build extra lanes.

Table 2-1 below gives a summary of some important characteristics of the study area:

Table 2-1 Summary of Study Area Statistics

Feature / Characteristic	Quantity / Size
Geographical Footprint	24.1 km ²
Population Density	1500 -1700 p/km ²
Road Length	Klipfontein : 9.2 km Lansdowne :7.3 km
Observed Mean Bus Stop spacing	714 m
Number of Main Signalled Intersections	Klipfontein : 11 Lansdowne : 5

Figure 2-3 below shows a map of the focus corridor in the study area and extracted from Google maps.

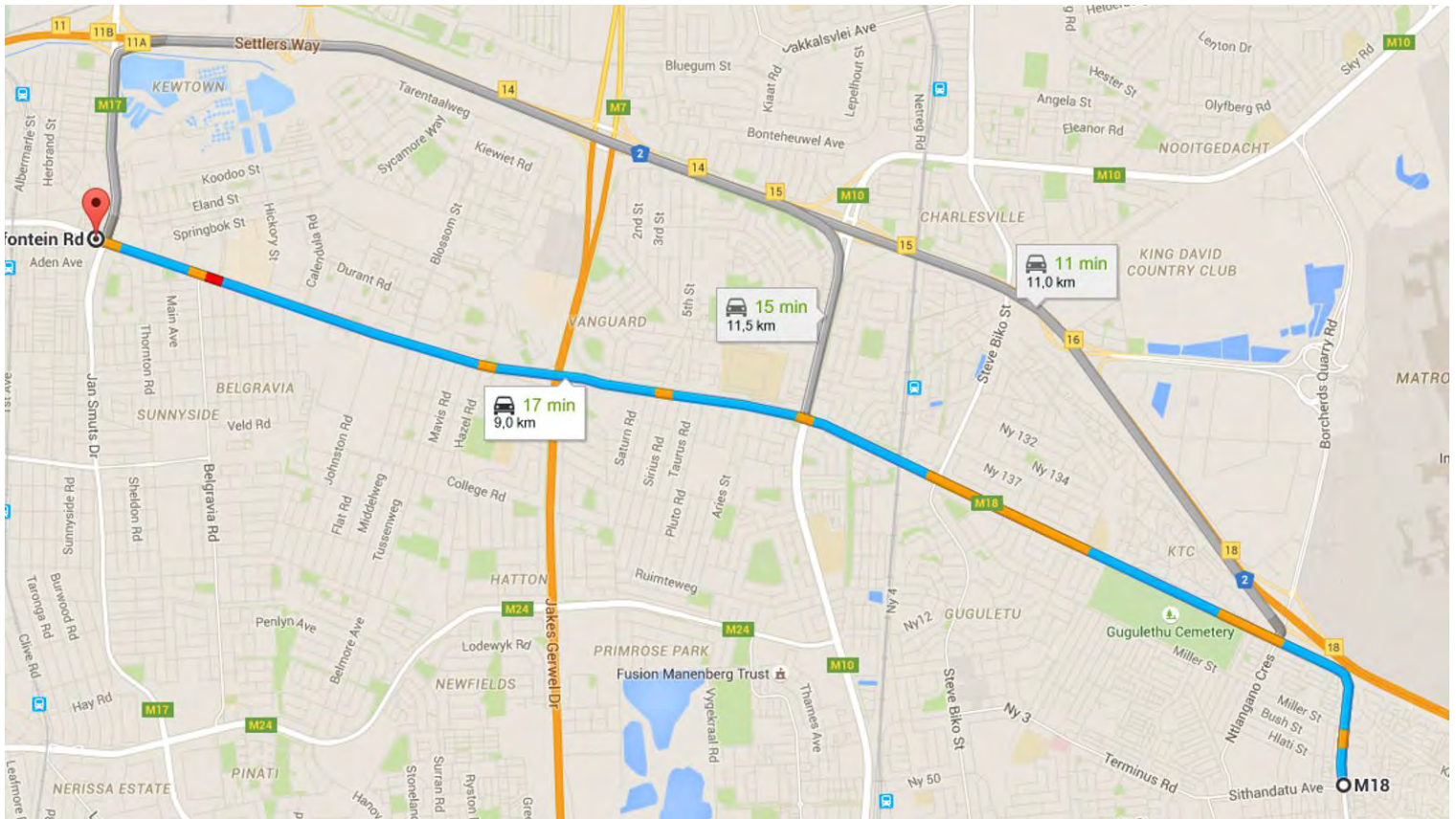

Figure 2-3 A Picture Of The Study Area Highlighting Klipfontein Rd (M18) in (blue) and some the alternative Roads Included In The Model Network(*Google Maps, 2015*)

The above map indicates a relatively high dwelling density which substantially increases westwards especially areas like Gugulethu (refer to Figure 2-3). This trend is due to the informal settlements and low income townships that the area is composed of while the more formal areas have lower density. Figure 2-3 shows the road network in aerial photo (Figure 2-3 above) as coded into PARAMICS and scaled to ensure realistic distance related data and travel times.

2.7 Development and Flow

This literature review begins with a problem statement and then is followed by a general introduction. An overview of public transport is given highlighting the different types of surface transport technologies in use around the world. Attention is then given to the public transport system design and operation by assessing the approaches to providing mass public transport. The fifth and sixth chapters focus on types of public transport priority schemes by showing examples and context of use. Finally, theoretical basis of issues around costing and computational modelling of public transport systems are addressed. Figure 2-4 shows a summary of the sequence of activities which are part of this study.

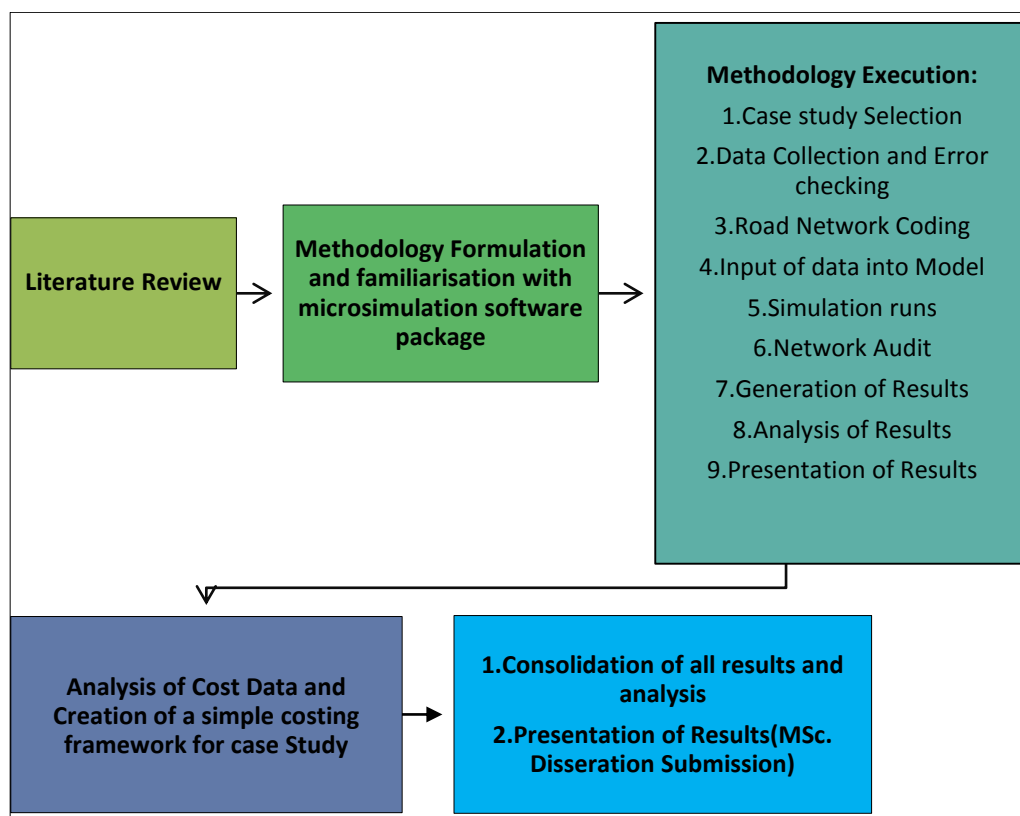

Figure 2-4 Flow Chart of Planned Execution of Study

Figure 2-5 shows a summary of the key ideas that informed this research project. In essence, it illustrates that this is a comparative study of bus priority measures which are feasible in a South African context.

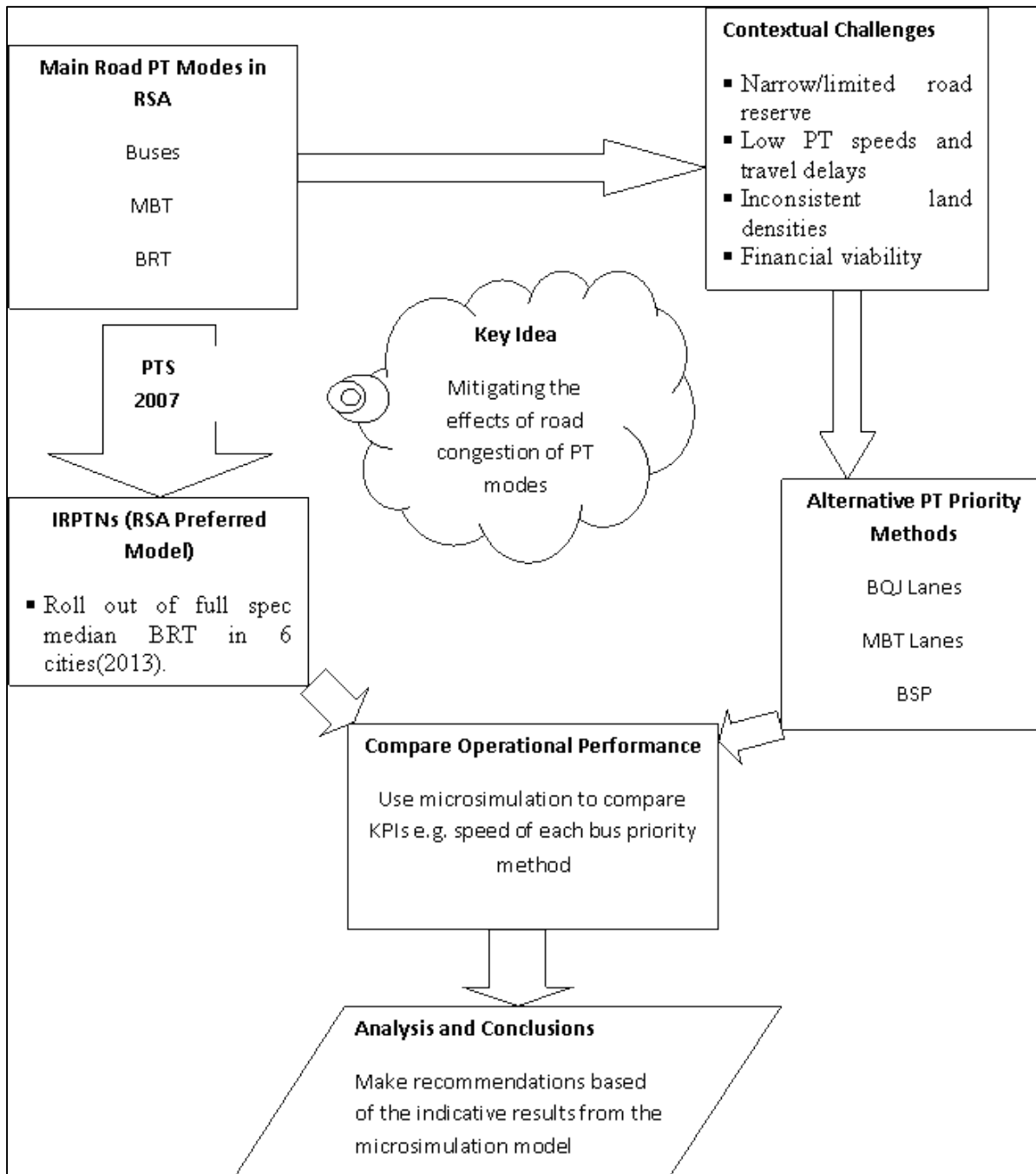
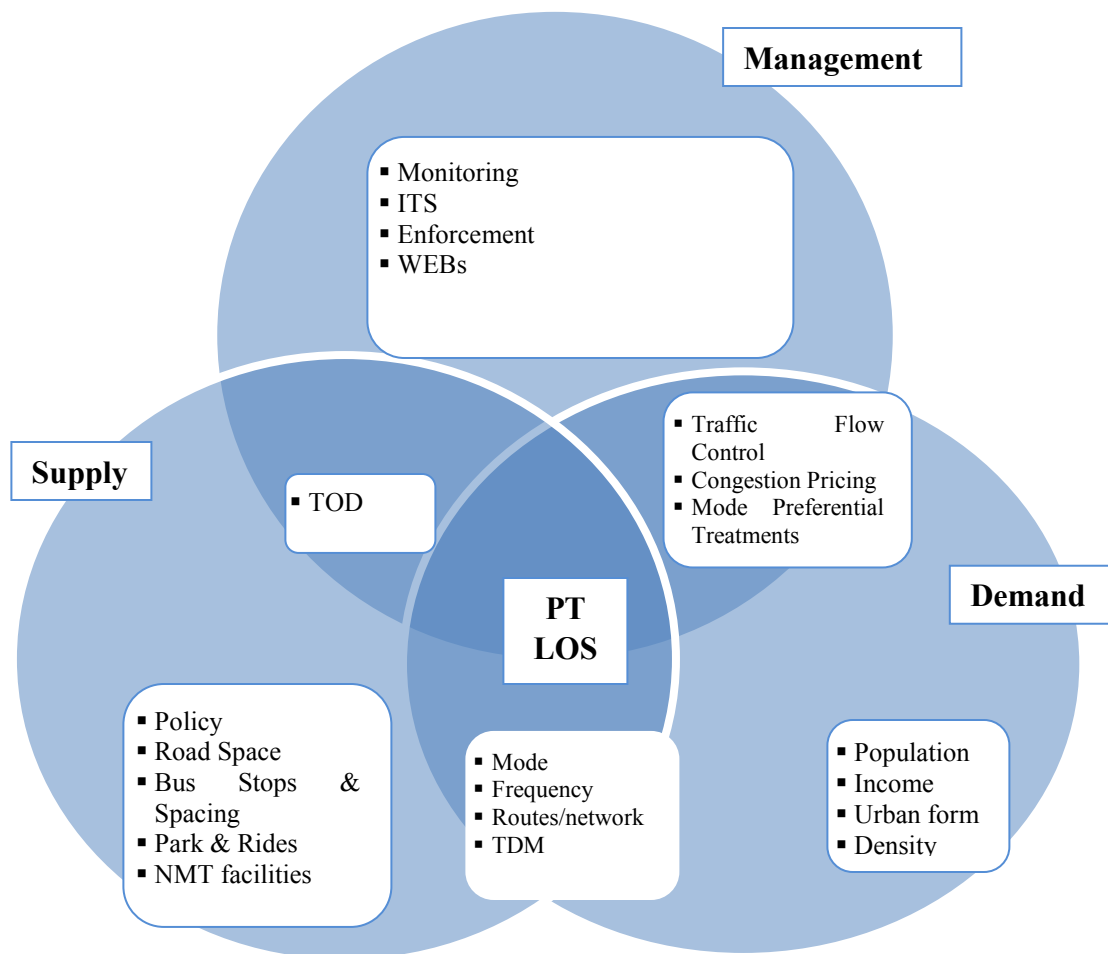

Figure 2-5 Study Research Structure

2.8 Research Mind Map

The mind map above highlights the key issues underpinning this research. It illustrates the three main factors that govern public transport (PT) and transport systems in general .i.e. Transport Supply, Demand and Management. There many overlapping issues or relationships between these main factors as shown in the diagram.



ITS: Intelligent Transport Systems

LOS: Level of Service

NMT: Non-motorised Transport

TDM: Travel Demand Management

WEBs: Wider Economic Benefits

The framework presented in this mind map is universal across PT modes such as rail, bus and NMT. However, the focus of this study is bus modes and the LOS improvement strategies that apply to them. The provision of urban mobility at an acceptable LOS is ultimate objective of most public transport systems and operations, as indicated by its central position in the mind map.

3 Literature Review

A review of literature reveals mainly two main schools of thought with regard to increasing bus transit reliability and capacity; the first being the advocates of full specification BRT systems which typically include public transport (PT) priority schemes, such as Dedicated Bus Lanes (DBL) along bus routes, the ITDP and the World Resources Institute (WRI) through its EMBARQ program, are among the strongest promoters of this model (Hidalgo and Carrigan 2010; Lloyd Wright and Walter Hook 2007). The second school of thought suggest an alternative approach to improving bus performance, recent research has shown that the implementation alternative PT priority schemes like BSP on their own can achieve similar or greater reductions in bus delay and travel times especially at intersections (Barker et al., 2003; Skabardonis and Christofa 2011; Kim et al. 2012; Dion, Rakha, Asce, and Zhang, 2004). In recent presentation Salvucci (2014) of MIT states the following:

“More traditional bus services, and modestly improved bus services, continue to be essential in corridors with narrow street widths, and modest existing land use densities. These are usually essential to any goal of offering access to the entire metropolitan area, and should not be designated as “BRT-Lite” and “Not True BRT”

These contradictory findings raise questions about the necessity of implementing full specification BRT in South Africa while it may be possible to extract similar benefits by employing partial bus priority measures at strategic locations along the BRT corridors. Since BSP and related measures that deviate from the DBL BRT model are relatively cheaper and flexible, they have the ability to ; substantially reduce capital and operational expense of municipal authorities (MAs) on BRT projects.

This section contains a review of local and international literature, .It is divided into four (4) main sections namely; an overview, of transport systems, Transport Policy, BRT and Traffic Modelling.

3.1 The Transport Demand

The Transport or Travel Demand is a fundamental element of all transport systems because it consists of all the travelling population. In South Africa the income level of an individual is a critical determining factor of their travel demand and mobility patterns.

This observation is incongruent with trends in more developed nations where travel demand and policies for Travel Demand Management (TDM) are mainly driven by the environmental agenda i.e. lowering greenhouse gas (GHG) emissions and reducing congestions in larger cities.

3.2 The Transport Supply

The transport supply is a basic component of any transport system. Most transport improvement programs focus on this part of this sector of transport. The research of will focus on the operational performance of the parts that make up the transport system.

The information from literature implies that the Transport Supply is composed of three interlinked parts namely: Policy, Infrastructure and Operations. Public transportation in all its forms is a matter of wide-spread concern to all inhabitants of a region and affects every facet of modern life. Hence it can be drawn from literature that transport policy and infrastructure, particularly; are either reactive or pre-emptive of the demands of the people and commercial and industrial requirements (O'Flaherty et al. 1997).

This section presents an overview of commonly used public transport systems around the world, particularly those that are feasible in South Africa and outlines local experience with some of these transport technologies. Furthermore, it explores the need and urgency for quality and dignified public transport in a South African context.

3.3 Characteristics of Public Transport

The term mass transportation or , more commonly public, transport is used to describe systems which exhibit the following characteristics:

- Transport relatively large groups of people typically ranging from 5,000 to 170,000 passengers per hour.
- Operate on fixed routes
- Follow a set timetable or schedules
- Particularly suited to catering to peak hour commuting

3.4 Categorisations of Public Transport

There are a variety of modes that are in use for public transport (PT). The PT modes with the largest capacity are usually rail based or metro systems. There is also a renewed interest in bus-based mass transit options given the distinct advantages they offer.

However, most developing countries have inadequate or non-existent public transportation systems which leaves a gap between travel demands, especially at peak times. This service gap is often filled by private operators of transit vehicles which is less structured; this type of public transit is called *paratransit*.

According to Wilson, Nigel, and Attanucci (2010), public transport modes can be grouped according to three criteria, namely Capacity, RoW and Technology. Based on the policy framework (refer to section

2.4.1) in a given jurisdiction these criteria influence the cost, operations and the efficiency of a particular PT system.

3.4.1 Capacity

Capacity directly relates to the travel demand of a given location(s) as stated in Section 3.2, Travel demand is the entire population which needs mobility i.e. to move from one point to another. Therefore, capacity can be defined as the number of passengers a transport mode can convey in unit time at a certain LOS. The most commonly used units are passengers per hour (pph) or in some literature passengers per direction per hour (ppdph).

3.4.2 RoW

The right-of-way refers to the portion of the road reserve designated for use by a particular mode. For the purposes of this text it is further used to indicate the level of segregation from other types of surface transport. Examples of segregation include grade separation which has been used extensively in some cities like Chicago, USA and use of bus lanes which are characterised by road marking;

However, weak enforcement of such measures in countries like South Africa means that the roll-out of such measures in various busy road corridors have been ineffective in improving the operational speeds of PT buses (Kumar and Barret 2008).

3.4.3 Public Transport Technologies

Technology is commonly used to differentiate transport modes. It refers to four critical aspects of which define a mode, namely:

- contact interface which includes rails or rubber tyres
- propulsion systems,
- lateral guidance which closely relates to the RoW and the control mechanisms e.g. driverless technologies, manual etc.

However, newer legislation and transport policy is moving away from placing emphasis on the specific technology rather than on its capacity and intermodal capability as elaborated in Section 3.9 “Singular vs. Intermodal Approach”. The following sections detail the key land based public mass transit technologies.

3.4.4 Rail Based Systems

There are three main variations deduced from the literature which is Heavy, Light and Metro Rail configurations. All of the aforementioned use their flanged wheels to move along parallel guide tracks called railways. The main purpose of the rails is to provide guidance and support for the train carriages and locomotive.

Heavy Rail and Metro are railways which usually meet the same national railway standard with the primary difference being that heavy rail can support freight trains i.e. heavier loads in addition to larger

passenger loads. Metro rail often do not form part of the national railway or long distance network thus are limited to the boundaries of the metropolitan areas they serve (David Catling et al, 2005).

The nature of rail infrastructure most often allows it to benefit from exclusive right-of-way. This means only approved vehicles i.e. trains that conform to the national rail standard can use the track and it has higher priority at intersections (e.g. railway crossings) than road traffic.

Table 3-1 Some Average Daily Train Ridership Figures from Different Countries (various website sources)

Passenger Rail Service Name	Location	Daily Capacity
New York Metro	New York City, USA	+7,900,000
Tokyo Metro	Tokyo ,Japan	+6,300,000
Delhi Metro	New Delhi ,India	+2,300,000

3.4.5 Light Rail Transit (LRT)

Similarly, Light rail is also highly localised to urban areas or sections of the city with high PT passenger volumes. It has lower capacity than Metro. Light Rail or Trams are designed for carriages of passengers and usually have sections that operate within normal vehicle traffic i.e. guide tracks or rail run along sections of the road but in exclusive lanes (David Catling ,Interfleet Technology Limited et al. 2005).

3.4.6 Newer Rail Technologies

There are a variety of rail technologies that have emerged in the past 30 years, including Magnetic Levitation (Maglev) and Personal Rapid Transit (PRT).

The only commercial application of Maglev is a 30 km line in Shanghai, China; which reaches speeds of up to 400 km/hr. The prohibitive costs which stand at about \$300 million per km, currently makes an impractical solution to mass rapid transit (MRT) for most cities.

Conversely, PRT combines the flexibility of private car travel with efficiency of public transport. They use driverless technology i.e. fully automated and can carry up to 4 passengers per unit or “pod” points along a guide path. PRT vehicles are guided along paths similar to guided buses. This relatively novel mode is being roll-out in especially large installations such as airports.

3.4.7 Bus Based Systems

The bus based public transport systems make use of different types of buses to provide a PT service to customers. Buses conventionally operate on urban roads and can carry anything from 12 to 300 passengers per bus depending on capacity and regulations.

The vehicle is usually supported by infrastructure such as bus stops and modal interchanges to allow for boarding and alighting of passengers at a pre-determined point on a fixed route that the bus follows. Ideally, an established PT bus service operates according to a specific schedule or timetable (Wright and Hook 2007).

Paratransit represents a deviation from the conventional bus PT service model as outlined above. The buses are usually have a smaller capacity of less than 40 passengers and do not follow a fixed timetable and route. This is the most common form of public transport especially in most African cities (Kumar and Barret 2008).

Consequently, this has resulted in a PT system; where MBT which are poorly regulated and have dismal road safety record dominate the industry (65 – 70%) of passenger trips, while the scheduled or formal bus services suffer from wide-spread negative perception, poor service quality and affected by traffic congestion.

3.4.8 Public Transport in South Africa's Urban Areas: Status Quo

Mini-Bus Taxis are the most common form of road public transport accounting for at least 65% of passenger trips in South Africa's urban areas such as Cape Town, as shown in Figure 3-1 However for the Johannesburg area, MBT commands as much as 72% of the modal share by some estimates.

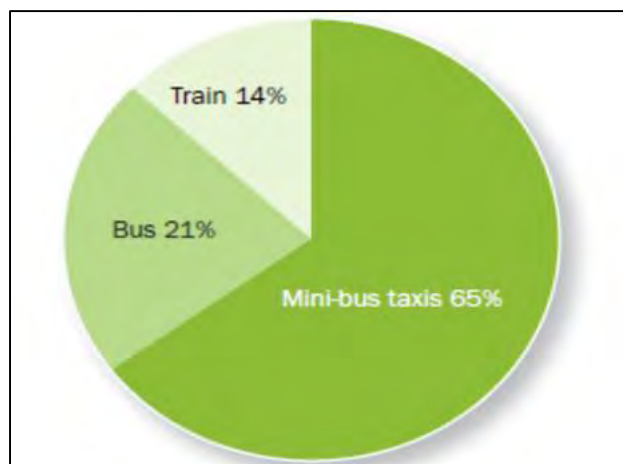

Figure 3-1 Modal Split of South Africa's Urban Areas

Source: (CoCT, 2011)

The highest numbers of taxis operating on most routes often means that they are oversaturated and leading to aggressive driving as drivers compete for customers. Figure 2-7 and 2-8 show the service quality offered to users is very poor often characterised by overloading and a dismal road safety record.



Figure 3-2 Minibuses in Cape Town

Source: <http://www.capetown.gov.za/en/PublishingImages/News%20Images/taxi16.jpg>



Figure 3-3 Typical Experience of Public Transport for most Commuters in South Africa

Source: <http://www.world-nomad.com/wn-uploads/mozambique-packed-crowded-minibus.jpg>

There are 60 private bus service operators that receive government subsidies through the respective provincial for their services. Golden Arrow is the main operator of public bus services in the Cape Town

Metropolitan Area and it uses a fleet of over 900 buses covering in excess of 1000 routes across the region. Figure 3-4 shows an example of the buses of which the GABS fleet is composed of.



Figure 3-4 A Typical High-floor Public Bus in Cape Town

Source: <http://drupal.in-cdn.net/cdn/article/public/capetown4.jpg>

The statistics reviewed indicate that rail has the highest capacity for public passenger transport and forms the basis of mass transit in Cape Town particularly some studies show that over 600,000 daily passenger trips are made by train. However, the lack of integration between modes still presents a challenge to users as all PT networks currently work in parallel with each other.

3.5 Context: Why Improvements In South Africa's PT Are Needed?

Public Transportation in South Africa is in a poor state and suffers from negative perception. It is primarily a mode of transit for captive user's i.e. those cannot afford to use a more comfortable, safer and dignified mode.

South Africa's urban areas have a characteristic pattern of spatial disaggregation of area based on economic activity and income levels (Vanderschuren, 2006). This means that areas of the city are allocated for a particular type of activity based on the municipal zoning schemes i.e. areas can be/are designated as commercial, industrial or residential. There is also a more subtle separation between areas of comprising mainly of lower income groups from more affluent areas. This is one of the remnants of Apartheid era (1948 – 1994) town planning.

This means that the people from lower income areas usually live far from their work places and other social amenities. This translates into an average travel time of *65 minutes* for most urban commuter when

using PT. The status quo is exacerbated by the inadequate PT services to most townships and informal settlements. (CoCT), 2011)

The aforementioned service gap is filled by the MBT. These are privately own and profit driven operations; the lack of strict regulation of the MBT industry has resulted in intense competition between operating resulting in violence and high accident rates due to unsafe driving practices. Therefore, the need for quality and dignified PT systems cannot be over-emphasised.

3.6 Transport Policy and Bus Priority

In the context of this review: policy will make reference to legislation both *de juris* and *de facto*, regulations and policies regarding all aspects of public transportation. According to Hounsell (2003); the provision of sustainable urban transport systems is the focus of transport policies in order to reduce traffic congestion and pollution.

However, in South Africa, these transport policies have the additional challenge of formally addressing the issues of social equity closely associated with the legacy of Apartheid and the urgent need for service delivery particular to urban peripherals which have typical demographics such as high population densities and lower income groups.

Most literature sources agree that policy formulation is the first step of the development or initiation of any urban transport program or initiative. This is because in the process of formulating policy, authorities are able to objectively determine the travel needs of a given region and clearly define how this is catered for. Furthermore, the LOS to which transit mode must be explicitly stated to allow for service standard is to be established as this eventually determines the operational constraints of PT systems.

Policy sets the upper and lower bounds of transport service and network quality i.e. defines the scope or extent of PT operations. In recent years the importance of policy has received increased attention with renewed interest in Travel Demand Management (TDM) which is a policy driven mechanism. In the past authorities have dealt with increasing travel demand by pursuing infrastructure expansion programs i.e. increasing road network capacity for vehicle traffic e.g. widening roads . These expansionist policies, especially in developing countries have served to encourage private car ownership, often at the expense of investing in PT infrastructure. In many countries, these policies remain the status quo, although many recognise that this situation is unsustainable in view of the social cohesion, economic, and environment they face.

There are different approaches suggested in literature and PT policies around the world, with some placing emphasis on land use planning also called Transit Oriented Development (TOD) and others who favour traffic hierarchy among network users which can be referred to as strong PT priority measures or systems. The North American experience seems to offer a third approach which is related to both aforementioned approaches, which emphasises assessment of policy implications at particular points in existing or proposed transport networks.

Policy establishes a common standard although it is often vague on critical factors ,such as safety which are relatively abstract but very important considerations in the modal choice among users (Behrens and

Jobanputra 2012) .With regard to policy formulation ; Hidalgo and Carrigan (2010) highlights institutional constraints such as political interference, inadequate planning and forecasting of policy. There is focus on implementation without a full or,at least ,exhaustive understanding of the implications the underlying policies. For example, there is little insight on how the specific performance standards as outlined in the Public Transport Strategy (2004-2020), were arrived at and if there are feasible in South African urban conditions.

Therefore it can be seen that there is a need to conduct detailed multi-disciplinary analysis and modelling of the transport policy, such as this one .This is in an effort to quantify the policy objectives and effects to provide a sound basis for alignment of PT operations and management to envisioned outcomes.

Overall public translates into the parts of the transport system that people interact with. This includes but is not limited to accessibility of PT facilities (distance between trip origin and bus stop) a, frequency of service, fares and universal access of actual facilities. As Figure 3-5, below shows the overarching role that PT policy in every component of the transport system.

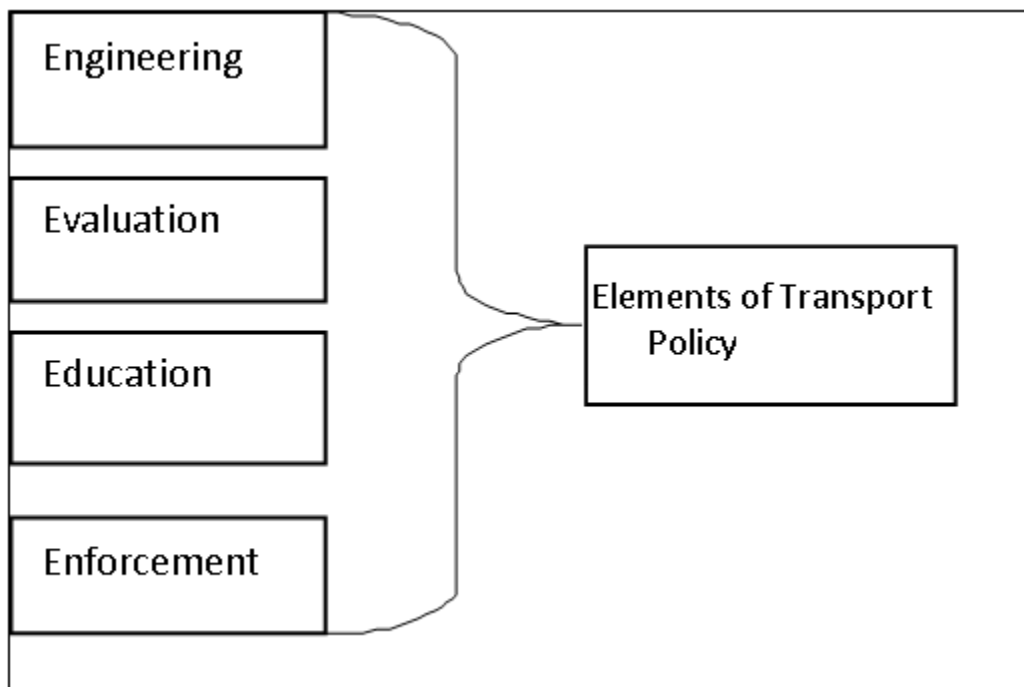
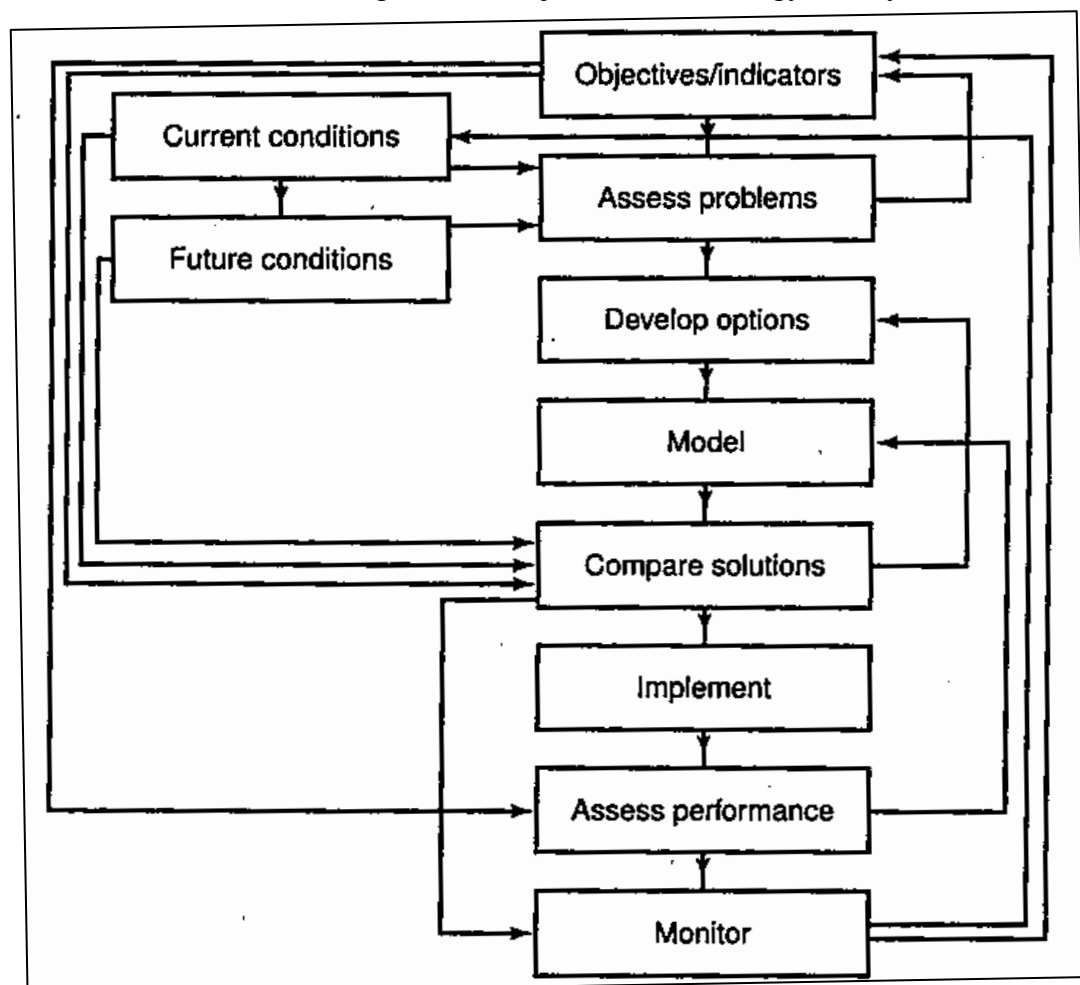

Figure 3-5 Policy Affects All Facets Of A Transport System

(Adapted From Transport Modelling [END 5048Z] Course Notes (Vanderschuren, 2012))

In the text “Transport Planning and Traffic Engineering”, O’Flatery et al (1997) summarise the different types of policy formation processes into two broad categories namely *Objectives- Led* and *Problem Oriented Policy* formulation. The major difference in approaches is the starting points: while the Guiding Policy policy makers begin by defining the objectives others start by identifying the problems and then comparing to the status quo or possible future scenarios.

These situations are illustrated in Figure 3-6 “Objective-Led Strategy/ Policy Formulation Structure”



below:

Figure 3-6 Objective-Led Strategy/ Policy Formulation Structure

From the above information it can be inferred that there exists an inherent risk in all forms of policy formulation; such as the risk of failing to consider the more subtle but wider implications of policy. This can often be overcome with use of well-adjusted predictive methods such as microsimulation and simulation. However, there is often a shortage of skilled personnel especially in developing countries' institutions to inform policy makers hence this step may be overlooked (Hidalgo and Carrigan 2010).

A nation's transport is representative of the government's strategic objective for providing its population with acceptable mobility and accessibility to opportunities and travel desires. Therefore, it is essential that any discourse on improving PT performance includes an outline of the government's public transport policy and all transport changes or innovations will have to be relevant to these set strategic frameworks.

3.7 South Africa's Public Transport Policy

This section highlights the government's current policy and legislation that guides the roll-out of improved land based public initiatives such as BRT, which is often referred to Integrated Rapid Public Transport (IRT) by MAs i.e. expressing the need to integrate public transport mode in urban centres. Figure 3-7 “the evolution of South Africa's policy framework from 1996 to Present (Walters 2013)” below shows the evolution of public transport policy in South Africa over the past two decades.

In South Africa, a PT system and its specifications must adhere to the law and technical specifications as set by the national and provincial spheres of government. Therefore this calls for all actions, procedures and policies by Municipal Authorities (MA) and appointed agents to be aligned with legislation such as:

- Overall transport operations and network : NLTA #5 of 2009 and NRTA
- Public Transport Vehicle Specifications : National Road Traffic Act (NRTA) # 93 of 1996
- Rail Related PT operations and safety: Rail Safety Regulator (RSR) Act of 2002
- PT Operators, Labour Relations and Condition of Employment: Basic Conditions of Employment Act 123 of 1993.

This pattern is consistent with practice in various developed and developing nations around the world. The policy framework has far reaching implications in terms of the PT infrastructure implementation and business models associated with subsequent operations.

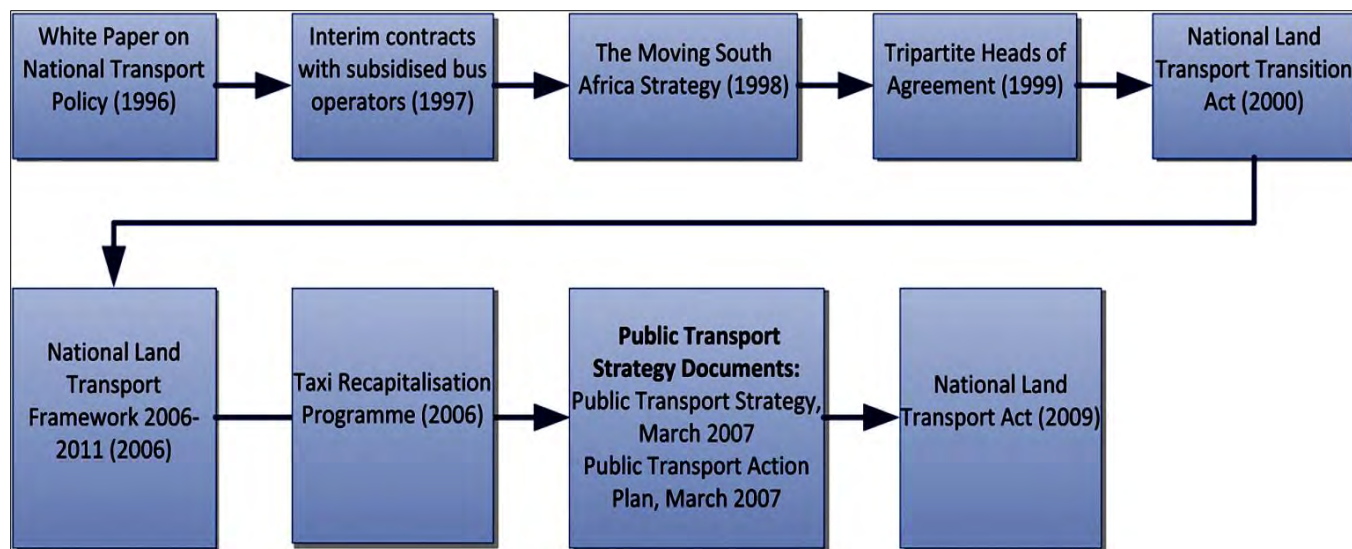

Figure 3-7 The Evolution Of South Africa's Policy Framework From 1996 To Present (Walters, 2013)

The key elements of Bus with High LOS (BHLS)/BRT systems as described by various literature sources and explained in Section 2.11 coincide with the South Africa's Public Transport Strategy (PTS) vision particularly of road based bus transport for the future as in the PTS outlined below.

According to the PTS (2002), IRPTNs are mode independent and offer a total service quality package over the entire user journey experience. The following is a list of features found on some of the most successful road based Rapid PT systems:

Physical infrastructure

- Segregated busways or bus-only roadways predominantly in the median of the roadway
- Existence of publicly managed integrated “network” of routes and corridors
- High quality publicly owned and managed stops, stations, terminals and depots
- Enhanced stations that are convenient, comfortable, secure, and weather-protected stations provide level access between the platform and vehicle floor
- Special stations and terminals to facilitate easy physical integration between trunk routes, feeder services, and other mass transit systems (if applicable)
- Improvements to nearby public space.

Operations

- Frequent and rapid service between major origins and destinations
- Ample capacity for passenger demand along corridors
- Rapid boarding and alighting
- Pre-board fare collection and fare verification
- Fare-integration and free transfers between routes, corridors, and feeder services

3.8 Public Transport and Traffic Congestion

Bus public transport often operates in mixed traffic without priority. The increasing modal share of private cars means that PT modes are competing for road space with less efficient transport modes. Therefore, PT is subject to the same delays as any other mode using the roads. This is an unsustainable model for urban mobility .i.e. as evidenced by the rapid raise in air pollution and road congestion associated with exponential growth in private vehicle traffic in many cities such Beijing.

The long travel time i.e. the national average is estimated to be 65 minutes and lack of comfort and safety when using PT has prevented it attracting choice users because of its negative perception in many urban contexts (Behrens and Jobanputra 2012). three main classes of motor vehicles on South African

roads namely , motorcycles, light motor vehicles (carry less than 16 passengers) and heavy motor vehicles. Mass Public Transit Vehicles, therefore, fall under the latter category. According to Section 1.0 of the NTLA, a bus is defined as a motor vehicle designed or modified to carry more than 35 persons including the driver (GCIS-RSA, 2009).

All these types of vehicles can be observed on South African roads but various sources indicate that private motor car dominates passenger transport in most urban areas. The daily average private: public modal split for the CoCT is estimated at 69:31((CoCT), 2011).

The private car is an inefficient travel mode due to its low occupancy rates i.e. an average of 1.6 persons per vehicle (Vanderschuren, 2006). This means that there is a disproportional road space taken up by the private cars mode and its capacity to transport people.

This inconsistency and efficiency in urban mobility patterns has been identified and recognised as unsustainable given the realities of rapid urbanisation and environmental conservations objectives (Policy, 2005);CoCT 2011).

3.9 Application of Priority to Public Bus

The key of objective of public transit systems around and most important customer requirement is reliability. This system characteristic is also the most difficult to deliver by PT operators because it is dependant of a number of external factors such as the high levels of congestion on public roads and signal delay i.e. at intersections.

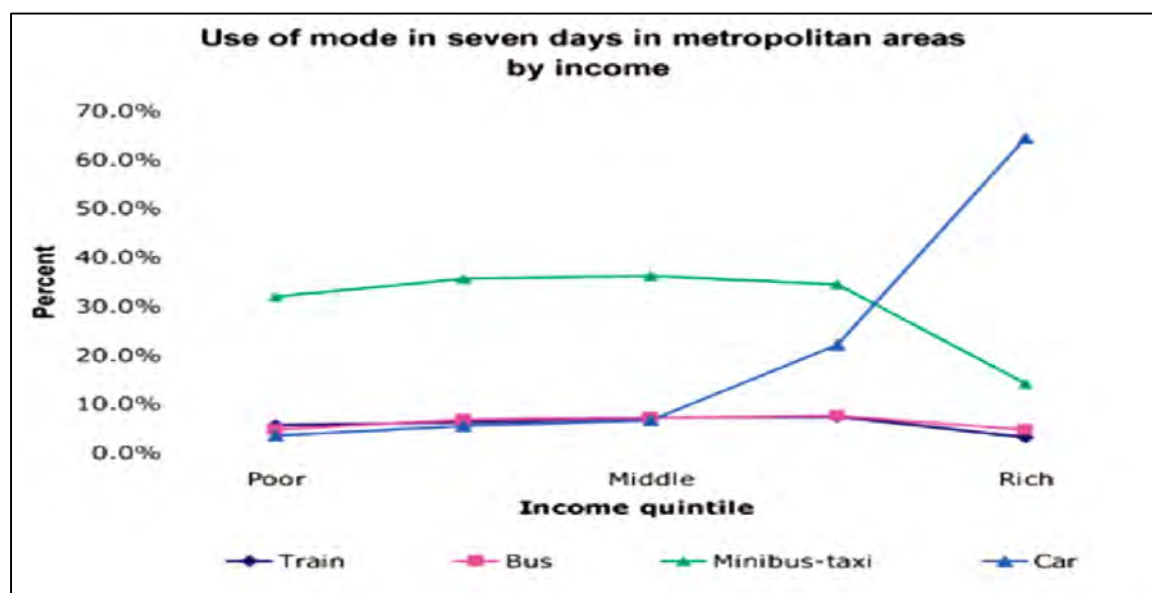

Figure 3-8 Illustration Of The Link Between Income Level And Transport Mode Choice

Source:: (City of Cape Town, 2011)

Public Transit Priority Schemes are deliberate and often successful solutions to the problems of PT schedule adherence and travel delay reduction (Kim et al. 2012; Xu et al. 2010; Skabardonis and Christofa 2011). PT priority scheme or measures is collective term referring to different operational and infrastructural interventions to give preferential treatment to high occupancy modes over other modes on given road(s) and intersections along a IRPTN corridor or network.

Furthermore to this the NRTA provided specifications for the road marking and associated facilities to constructed as part of an Integrated Rapid Public Transport Network(IRPTN)((Department of Transport), 2007). The Figure 3-8 “ Showing some basic elements of the a South African BRT System (Rea Vaya, Johannesburg)” below shows an example of dedicated bus lane ,universal access station which allows at-grade boarding, articulated bus and lane separation marking which all form part of the first full specification BRT system built in South Africa which is Johannesburg’s *Rea Vaya*.



Figure 3-9 showing some basic elements of a South African BRT System

Source: <http://www.sustainable.org.za/>

3.10 Types of Bus Priority

The following outlines the main types of priority schemes as mentioned above and described in various academic and operational literature texts. PT priority schemes can be either operational or infrastructural in nature. In reality, the implementations of recent BRT systems use a combination of both measures however some jurisdictions have achieved their objectives while utilising operational measures only (Hidalgo and Carrigan 2010).

3.10.1 Operational Priority Measure (OPM)

Operational Priority Measures (OPM) refers a set of ITS strategies used to provide PT priority, they are focussed on digital or analogue technologies that are not necessarily tangible, to grant road space preference to buses or other PT modes and improve system efficiency. In traffic engineering, they are also referred to as *light priority treatments* (Hensher and Golob 2008). The most common forms of OPM are Transit Signal Priority (TSP) or in the case of BRT systems BSP.



Figure 3-10 An Example a Bus Priority Signal Installation

Source: (http://www.th.gov.bc.ca/popular-topics/images/faqimages/bus_priority.jpg)

TSP involves adjusting traffic signal timings to ease the passage of PT vehicles through signals particularly at intersections. It can be taken a step further by coordinating the traffic plans along an entire corridor (Lee et al., 2007). These are detailed in Section 5.3 “BSP”.

3.10.2 Infrastructural Priority Measures

Infrastructural Priority Schemes are the priority measures that enforce the preferential movement of PT vehicles along corridors by means of physical barriers and modification of standard road geometry. These constitute the most expensive suite of PT priority measures. The Figure 3-11 below shows an example of a strong priority measure for high occupancy which can be used as an exclusive bus lane as will be later explained.



Figure 3-11 barrier separated High Occupancy Vehicle (HOV) Lane

The level of priority given to PT has considerable cost implication from a construction, enforcement and operations perspective. The Figure 3-12 provides an indication of difference in running costs of the types of BRT running way from the North American experience as of 2004 (Lee et al., 2007).

Component	Cost (Millions)
<i>Running Way Type</i>	
Grade-separated busway	
Below grade (tunnel)	\$60 to \$105 per lane-mile
Aerial	\$12 to \$30 per lane-mile
At-grade busway	
Separate ROW or median	\$0.5 to \$10.2 per lane-mile
Arterial lanes (reconstructed)	\$2.5 to \$2.9 per lane-mile
Mixed flow lanes - queue jump	\$0.1 to \$0.29 per lane-mile
<i>Guidance Type</i>	
Optical	\$11,000 to \$134,000 per vehicle
Electromagnetic sensors	\$20,000 per mile
Hardware and integration	\$50,000 to \$95,000 per vehicle

SOURCE: CBRT (1)

Figure 3-12 Typical BRT Running Cost (Excluding Right-Of-Way) (Lee et al., 2007)

The application and choice of priority measures used on a particular BRT system is context specific. The context includes the degree of car restriction policy, political support, cost and geographical constraints.

3.11 Measuring the Performance of Bus Systems

In the previous Sections 3.6 - 3.5 a number of feasible and currently used road priority measures which apply mainly to buses (but in some cases LRT or Tram Systems) have been described. As expected these have varying degrees of impact and degree to which they can improve certain key operational factors or indicators of a PT system like BRT/BHLS.

However it remains that bus priority measures are implemented to improve or ensure that the productivity and efficiency of a given PT fleet is increased by shifting indicators into a positive domain. The **KPI** are defined as system design characteristics that are used as proxies for enhanced performance and customer experience (Hook et al., 2013). The following sections will seek to explain the KPIs detailed in literature, in relation to the performance of a bus based PT systems and ultimately the classification of BHLSs in this regard.

According to the “BRT Standard” (Hook et al., 2013), the measure of operational performance of bus service is based on five (5) essential elements namely:

1. Busway Alignment
2. Dedicated Right-of-Way (D-RoW)
3. Off-board Fare Collection (OFC)
4. Intersection Treatments
5. Platform Level Boarding.

It is clear that the above agree with the 6 basic elements of BRT/BHLS as explained in Section 3.11 despite some minor difference on points of emphasis and grouping. All these design characteristics reflect the outcomes described below (Section 5.6.2) such as system speed, reliability and capacity among others. As can be seen in Section 6.4 - 6.7, this paper focusses on BHLS/BRT matters relating to road space management which is (1.) and (2.) above and intersection treatments such as BSP.

3.12 Factors of BRT Performance

The economic value of enhanced public transportation systems as represented by BRT/BHLS is derived from the levels of customer usage they can achieve due to their relatively higher performance characteristics. In this section, the factors that can best describe the characteristics are detailed. The PT system performance characteristics are made-up of qualitative and quantitative elements that are called attributes, measures or indicators depending on the text source and context.

Although literary sources differ, in the parameters used to describe the aforementioned KPIs, points of agreement are evident throughout the literature reviewed. These common factors are Capacity and

Reliability. Further to these factors other parameters such as: User perception, safety and resource utilisation are explained in relation to this study.

3.12.1 Capacity

Capacity is a generic term but typically refers to passenger, vehicle capacity or way capacity of a given PT system. The passenger capacity can be defined as the maximum number of passengers that a PT system can carry safely and in acceptable levels of comfort. It is measured in terms of *passengers per hour per directions* (pphpd). Vehicle capacity is the maximum number of PT Vehicles (in this case buses) that can pass a fixed point in a given time interval at a certain LOS; it is measured in *vehicles per hour per direction* (vphpd). According to Vuchic (2007), the passenger capacity is more generally referred to as the Line Capacity (C).

Vehicle capacity relates to the concept of Transit Unit (TU). A TU refers to a set of n carriages/cars (within the context of this text) that travel together as a single unit; therefore in the case of BRT/BHLS it usually means a conventional or articulated bus. Hence, the number of TUs that traverse a point is called the *service frequency* (f) while the time taken between two successive arrivals or buses is called the *service headway* (h) or the inverse of service frequency. These are measured in buses/hour (**buses/hr**) and minutes respectively. These two parameters are linked in Equation 5-1 “Service Frequency”

$$f = \frac{3600}{h} \quad \text{Equation (3-1)}$$

Therefore, from the above Equation 6-1, it can be seen that the Line Capacity in TUs is governed by the *maximum frequency* f_{max} , which, in turn, is determined by the shortest attainable headway at all points and station along a PT route or the minimum headway (Vuchic, 2007). This leads to the definition of maximum offered line capacity (C) which is the maximum number of passengers that a transit line can transport. It is measured in passengers per hour and given the product of vehicle capacity (C_v), maximum frequency f_{max} and number of TUs (n):

$$C = f_{max} \times n \times C_v \quad \text{Equation (3-2)}$$

The increase of public transport different types of capacity as explained above lies at the core of most PT interventions including implementation of rail and BRT/BHLS systems. ITS measures, such as transit priority serve to enhance this particular indicator by allowing the existing infrastructure to serve more TUs in unit time and ensure system reliability.

3.12.2 Reliability

Reliability is defined as the PT system’s consistency in TU headways, arrival times and schedules (Daganzo, 2010). Basically, it is the frequency or consistency with which a given PT system can achieve its performance indicators or set benchmarks. It is one of the most desirable characteristics in a mass transit system especially by frequent users, therefore the need for careful consideration when designing a PT system cannot be over-emphasised.

This remains one of the challenging system attributes to design for; because of the intrinsic unreliability of PT systems. TUs running according to a schedule tend to *bunch* or pair and deviate from the design or policy headway.

3.12.3 Speed

An overview of literature indicates two paradigms to this indicator: firstly, some sources treat speed as a fundamental attribute of an urban PT system while other authors argue that it is more of an outcome or subset of system components and protocols. It is given in unit of kilometres per hour (**km/hr**). As a basic attribute speed is defined as in Equations 3-3 and 3-4 below; where (v is velocity, t is time and s is distance travelled):

$$v = \frac{s}{t} \quad \text{Equation (3-3)}$$

Arterial bus speeds are of particular interest to this study. They are influenced by a range of factors including: bus stop spacing, delays due to traffic lights, dwell times, turning movements across bus lanes, other buses and vehicles. The “Transit Capacity and Quality of Service Manual—2nd Edition” puts forward Equation 3-4 as the means to calculate arterial bus speeds but reiterates that direct measurement is the most accurate method for determining average PT bus speeds (Kittleson and Associates) et al. 2003).

$$S_t = \left[\frac{60}{t_r \times t_l} \right] \quad \text{Equation 3-4}$$

In the above S_t is the bus travel speed (**min/km**), t_r is the base running time (min/km), t_l is the bus running time losses (min/hr). Therefore, applying technological and operational improvements to a bus service or a cohort of the aforementioned has been shown to increase the average bus operations speeds.

3.12.4 Safety: Road Safety and Security

Safety has two critical aspects, namely road safety and security. Security mainly refers to provision of an environment that is free of criminality and deters it. This is often highlighted in academic studies and surveys as the major concern for potential users and captive users of PT modes such as buses. In general, Safety is describe as the severity and frequency of injuries and fatalities experienced by passengers and staff alike while using a given transport system.

Safety and Security are usually measured in terms of accident rates (per service hours or service miles) and public perception of safety respectively.

This measure is not the focus of this study but overall implementing of priority schemes such as turn-restrictions can reduce the number of conflicting movements at intersections along BRT/BHLS corridors and have shown to improve road safety performance while simultaneously lowering accident rates.

3.12.5 Resource Utilisation

This parameter is closely related to operation research. The concepts of consumption rate, utilization and efficiency form the basic elements for many common assessment procedures of mass transit operations. The consumption rate can be defined as a ratio of the amount of resource used to in a transport system to the magnitude of the specific output required of the transit system. It is summarised by Vuchic (2007) in the form of Equation 3-5 below:

$$\text{consumption rate(CR)} = \frac{\text{quantity of resource used}}{\text{quantity of output made}} = \frac{1}{\text{efficiency ratio}} \quad \text{Equation 3-5}$$

In the transportation context; consumption rates are useful are when comparing quantities with dissimilar base units. For example, indicators such as costs, energy units, labour and ridership can be associated via consumption depending on the kind of analysis being done. Conversely, Utilisation Rate is the ratio of same or very similar input and output indicators, therefore, usually computed and stated as a dimensionless number (percent or coefficient).

3.12.6 Public Perception

Public perception is a qualitative measure which gives an indication of the degree to which a PT system's characteristic satisfies user requirements and its ability to retain regular users and attract choice users. Most BRT/BHLS systems pay particular attention to rolling out distinct branding which makes it identifiable as offering a higher quality and LOS to users.

However most transit authorities in most cities where BRT/BHLS is being implemented are faced with the challenge of a legacy of negative perception of public transport modes i.e. commonly perceived as dirty, unsafe ,uncomfortable, for use by low income groups and unreliable(See Section 1).The critical role of this indicator lays in fact that the justification for investment in BRT/BHLS infrastructure is partly based on a given system potential to cause modal shift to PT especially in high demand corridors during peak travel times.

3.13 BRT/Transport

BRT refers to a bus based set of PT technologies which aims to provide higher passenger carrying capacity through dedicated right-of-way to increase speeds and quality customer service. It generally seeks to emulate the capacity and speed performance of rail mass transit but with the added flexibility of bus services.

The relatively low cost of implementing a BRT has led to its popularity across the world as means of mass PT. Table 2-3 shows that ,in the period from 2001 to present, over 104 cities have adopted or built BRT systems that serve over 29 million passengers on a daily basis (Global BRT Data, 2013; Wirasinghe et al. 2013). Overall, the construction and operation of a full specification BRT system costs less 4 – 5 times less than an equivalent rail PT system. This system focusses on a primary PT mode in this case buses ,and providing infrastructure to link it to the access modes at specific points on its route e.g. walking or cycling.

Table 3-2 BRT Systems Implemented Around the World

Source Data: (Global BRT Data,2012)

Regions	Passengers / day	Number of cities	Length (km)
<u>Africa</u>	238,000 (0.8%)	3 (1.9%)	62 (1.5%)
<u>Asia</u>	8,095,822 (27.6%)	33 (20.6%)	1,069 (26.0%)
<u>Europe</u>	1,686,966 (5.8%)	43 (26.9%)	688 (16.7%)
<u>Latin America</u>	18,132,783 (61.8)	54 (33.8%)	1,389 (33.7%)
<u>Northern America</u>	849,285 (2.9%)	20 (12.5%)	585 (14.2%)
<u>Oceania</u>	327,074 (1.1%)	7 (4.4%)	326 (7.9%)

3.13.1 Elements of a BRT System

From the literature surveyed infrastructure or systems and operations emerge as the main components of public transport (Vuchic, 2002) . However, Diaz (2004) further divides these two core components into 6 critical elements in the case of BRT systems. Figure 3-13 illustrates the key infrastructural elements of a BRT system.



Figure 3-13 A Conceptual Design Showing the Main elements of a BRT System

Source : (<http://www.city-data.com/forum/urban-planning/1216372-will-any-msa-have-better-brt.html>)

The six major parts of a BRT system are:

- Running/Guiding Ways
- Stations
- Vehicles
- Fare Collection Systems
- Service and Operating Plans
- ITS.

3.13.2 Running Way and Bus Priority

The running or guiding way is the surface and degree of separation it gives to the bus service using it. According to Levinson et al (2003) it is the fundamental infrastructure and central to the operation of a BRT system. Literature reveals a further set of three broad categorisations of bus running ways which are; On-Street, On-Freeway and Off-Street running ways. The On-Street and On-Freeway bus ways include at-grade mixed traffic lanes(most common),kerb side, median and bus-only streets (Wirasinghe,

Kattan, Rahman, & Hubbell, 2013b). Whereas Off-Streets implies running with grade separation which is achieved by elevated bus ways, bus tunnels and bus bridges.

The cost of construction or provision of right-of-way is the main factor in prevalence of running way type. Thus the mixed traffic lanes are the most common type of running ways used around the world including South African cities. This is because it is the cheapest form RoW as it uses existing road infrastructure and requires relatively little additional investment, if any. However, this means that PT modes like buses are subjected to poor LOS i.e. traffic congestion and delays, which normal vehicles encounter especially during peak hour travel which, in turn, reduces the service of reliability.

To mitigate the effects of traffic congestion on PT buses, a number of North American cities implemented Segregated Busways as early as 1969 which are now commonly referred to as DBL. However, sources agree that the first systematic integration of building running ways and improved bus operations was done in the Brazilian city of Curitiba in the early 1970s. Curitiba's BRT has become a model system which many cities from Bogota, Colombia to Guangzhou, China have emulated to solve their mass transit problems.

There have been a number of innovations particularly in the design of at-grade or on-street DBLs to help reduce delays and improve overall performance. These design improvements relate mainly to bus lane configuration and placement. The use of bi-directional lanes and inclusion of "passing" lanes at potential bottlenecks like stations has worked to eliminate delays from parked and buses which experience break downs. Bogota's TransMilenio is example of BRT system that integrated these features extensively throughout its network corridors as noted by Lloyd Wright and Walter Hook (2007).

Contra-flow and Reversible lanes are a couple of unconventional approaches to road space management. Contra-flow lanes allow the BRT vehicles to travel in a directional opposite to the normal traffic along exclusive lanes (Wirasinghe et al., 2013b). In this regard, Reversible lanes can be viewed as special types of contra-flow lanes in that the direction of the BRT flow along the reversible lane is dependent on the time of day i.e. during the peak hour the some of the lanes in the off-peak direction can used as *contra-flow lanes* only for BRT vehicles. However, studies indicate that these schemes are better suited for parts of PT corridors with low pedestrian friction as they are safety concerns with confusions arising to the unusual flow direction which presents a pedestrian hazard.

The placement of lanes in the road reserve i.e. kerb side or median has a considerable effect of the delay and possible disruptions to BRT because of the turning movements of normal traffic as is the case for kerb side lanes. This means that turning restrictions often have to be enforced to reduce the delays and risk of accidents from turning vehicles. However, consultations with Cape Town bus operator: GABS (2013), alludes to the point that median PT lanes pose a road accident hazard if they are not coupled with strict enforcement. This is especially the case at points in proximity close to on-ramps during peak traffic.

Lateral guidance is another key aspect of the running way. This means use of integrated ITS to maintain the required horizontal alignment of the PT vehicle within the R-o-W. The most important outcome of lateral guidance is that it allows for *precision docking* particularly at bus stations to facilitate safe and faster boarding and alighting of passengers i.e. bus dwell time (Barker et al. 2003). There is a broad range of guidance technologies ranging from; manual steering, mechanical, electronic and optical systems.

From a road space management perspective; the choice of lateral guidance can have implications such as reducing the RoW used by PT vehicles and increasing operating speeds.

3.13.3 Stations

Stations are the interface between the bus service (BRT) and its users. They are critical components of the PT system as they represent points of modal change i.e. walking to mass public transit. Vuchic (2007) makes a distinct between bus stations, stops and terminals. Bus stations are crucial PT infrastructure which are used to facilitate some key functions in addition to passenger boarding and alighting such as fare collection, giving or receiving information and shelter.

A bus stop is simply a defined location on a given bus route where it stops to allow passengers to disembark and board. While, a *terminal* represents a point of intermodality in the PT network i.e. user are able to transfer to another mode of transport such as: rail, car or one of the NMT modes. It can be seen from the above categories of bus station infrastructure; that final design of the BRT station is dependent on if the system is closed or open.

The “Characteristics of BRT for Decision-Makers”(Diaz et al., 2004a) summarises the key characteristics of enhanced bus service or BRT stations as :

1. **Basic Station Type:** this can range from basic shelter to closed, weatherproof structures. This varies according to the aforementioned functions expected to be carried out at the location. This design of the station particularly important with regard to passenger comfort, security and schedule communication.
2. **Platform Height:** this significant with regard to the universal accessibility requirements i.e. at-grade systems allow for easy boarding and alighting for physically challenged and visually impaired users. However, from an operations point of view it has shown to be a factor to consider when seeking reducing dwell times.
3. **Platform Layout:** the platform layout relates mainly to issues of bus berth configuration i.e. assigned or unassigned parking and bus docking mechanisms.
4. **Passing Capacity:** in an ideal situation bus stations especially busy ones should have provision for bypassing buses which are in stations as this can allow for running express lines and also to avoid system bottlenecks.
5. **Station Access:** this refers to how a given community is linked into the PT system. Most modern enhanced bus services adapt to the relevant access mode and should provide facilities to support all access modes which usually are NMT but in affluent communities vehicles maybe also be used. The station accessibility is usually expressed in terms of catchment radius which translates into outcomes such station spacing of 200m to 500m as recommended by various sources for BRT system (Department of Transport) 2007) (Wright and Hook 2007) (Diaz et al. 2004).

Each of the above outlined station characteristic’s dimensions are determined by the guiding policy objectives as expressed in design specifications for BRT stations. In the case of SA, these include

outcomes such as the universal access, safety and comfort which current infrastructure inadequately addresses.

3.13.4 Vehicles

The type of buses used to deliver a given PT service; are vital as a platform to embody the system's positive image, branding, environmental objectives and overall comfort to users and attracting choice users.

Literature sources highlight the following as critical considerations with regard to BRT type vehicles namely: Vehicle Configuration, Door Design, Vehicle aesthetics and Floor elevation (Wirasinghe et al. 2013). In addition to this vehicle propulsion systems and bus interior design like on-board Wi-Fi can serve to enrich the passenger experience with PT (Diaz et al., 2004b) (Wirasinghe et al. 2013).

1. **Vehicle Configuration:** the bus type range from conventional buses to articulated buses. This is important and varies according required capacity at different times during the day. This means that a PT fleet will have a systematically determined mix of bus types.
2. **Bus Door Design:** the number of doors and their design affect the efficiency of movement into and out of the PT vehicle, hence reducing dwell times. Since wider and multiple entry/exits can facilitate efficient distribution of passenger in vehicle by allows multiple streams of user motion.
3. **Floor Elevation:** there is choice of either selecting a bus with adjustable height or specifying station platform heights that match the bus height. This means that at-grade or level boarding can occur hence it allows for universal access which most ordinary "high-floor" buses and stations cannot adequately cater to.
4. **Vehicle Propulsion:** the importance of propulsion technology is mostly concerning fuel savings and addressing environmental objectives. Therefore, most BRT systems utilise improved diesel engine technologies although in more developed regions such as Western Europe alternative fuels and drive trains. Some pioneering propulsion systems include wide-spread use of biofuels such as sugar derived ethanol in Brazil, biodiesel (Western Europe), Hydrogen Fuel Cells and electricity i.e. the Trolley Bus system in Moscow (Kerkhof and Soulas 2011)s. It can be seen that BRT or enhanced bus system propulsions mechanisms can be adjusted to suit local conditions and as a means to maintain financial viability and environmental sustainability.

3.13.5 Fare Collection

The fare collection systems are another key distinguishing factor between ordinary PT service and enhanced bus systems like BRT. Fare collection system impacts the revenue, ridership, dwell times and overall usability of the PT. It is also one of the areas of PT operations where ITS measures like automated fare collection systems such as smart cards are readily applicable. This means that unlike the ordinary on-board fare collect systems currently in place as can be seen on Golden Arrow bus; Smart Cards technology allows for off-board fare payment. It is also worth noting that Golden arrow also have the option to buy monthly tickets at their stations but these still have to be checked by driver before boarding is permitted.

Most new BRT systems have adopted off-board fare collection, with varying degrees of flexibility and interoperability. Interoperability means that the card can be used as a generic electronic payment of fare across a range of modes and to pay for purchased goods and services like any other bank card. The benefits of using the off-board collections is the drastically reduced passenger processing times, lost revenue (due to non-payment, driver dishonesty and mishandling). This means that passenger convenience is increased and dwell times reduced. Therefore, it also works to improve schedule adherence, public perception and system efficiency.

3.13.6 Operating Plans and Control Systems

This refers to all the procedures and systems used to ensure delivery of the BRT service and it is more effective than ordinary buses. These include a cohort of mostly ITS related measures such as BSP especially at intersections, road space management protocols like exclusive lanes enforcement and Auto Vehicle Location (AVL). The reality is that the operational systems complement each other for instance; in the case of BSP some systems may integrate AVL to give signal priority only when bus is running late.

However, literature seems to overlook or underestimate the importance of organisational efficiency or internal management of the operators as key elements of success of operational control plans. This means that vital human resources such as drivers are managed through optimised scheduling to minimise undue labour costs. Effective operations systems work together to increase the PT service speeds and increase reliability. These are all significant in attaining the goal to attract and retain users which remains the challenge for many PT initiatives such as BRT.

3.13.7 Speed

In the context of this document: speed is defined as the rate at which mobility is achieved and is usually measured in km/hr. From literature it is a cumulative output because it is often the result of many other system components. In addition, it is one of the most easily measured performance indicators of any PT system.

Speed or Rapidity is a defining characteristic of enhanced Bus Services as is emphasised by the term BRT. It is often the one attraction factor to instigate modal shift to PT because of the higher speeds it offers or proposes especially during peak hour(s) along congested routes. Vuchic (2007) identifies Right-of-Way, TSP, the number and location of stops as being the most influential on the operational speed of transport systems like BRT. This conclusion is corroborated throughout literature, the use of DBLs in conjunction with BSP can have the most impact on the increasing the speed of bus PT (Wirasinghe et al. 2013) (Wright and Hook 2007). Basically, TSP allows buses to move ahead of general traffic and to make movements which all vehicles are restricted from doing, it is especially helpful for maintaining schedule adherence and for late buses to minimise their lateness.

The speed as a measure of measure and proxy for operational improvement in PT is elaborated on in Section 3- "Measures of Efficiency" of this literature review.

3.13.8 Passenger Information Systems

A survey of literature indicates that Passenger Information Systems (PIS) can either be static and/or dynamic. The availability and usability of PIS is a differentiating factor between PT systems and enhanced bus services like BRT systems are suitable platforms for wide-spread roll-out of PIS. Apart higher customer satisfaction which leads to increased ridership; an accurate PIS can reduce user wait times and provide additional revenue by selling advertisement space on Variable Message Sign (VMS) screens and various PIS avenues (Diaz et al., 2004a).

Passengers can use different types of PIS to access a variety of information about a given PT. This implies existence of a range of PIS from simple wall mounted timetables or maps, Variable Message Signs (VMS) which use Light Emitting Diode (LED) technology to mobile applications which provide all kinds of information about the bus service. The PIS technology used and the information communicated varies depending on the:

- Stage of the journey i.e. before, during and at destination node or journey termination. Technologies such as VMS can link to AVL to update message boards with the location of bus and expected time of arrival at particular station. It can be seen that such systems can substantially improve customer perception of BRT service by improving user friendliness (Wirasinghe et al. 2013).
- The appropriateness of technology i.e. intended reach and nature of information. This means that platforms such as mobile devices as compared to station mounted PT schedules are likely to have the widest reach in urban areas and can also provide on-demand information.

Overall, the success of BRT or BHLS systems is that they integrate all the above elements into a single mass public transportation system under a strong or well perceived identity (Muñoz and Hidalgo 2012). As can be seen from there is a wide variety of technologies available to maximise performance of PT systems. Although literature indicates differences in specifics of implementation; these differences are expected since public transport systems are a function of local conditions, availability of resources and context. The key issue extracted in this context is that BRT /BHLS model of provision of PT is flexible i.e. must be adjusted to suit location specific issues.

3.13.9 Integrated Rapid Public Transit Networks (IRPTN)

The Integrated Rapid Public Transit Networks (IRPTN) are an extension of the BRT concept to include all implemented PT modes such as rail, bus and non-motorised transport. This means there has to be deliberate system wide measures to increase speeds, user comfort, safety, and universal access on all modes which form the PT system; additionally it involves the integration of operations between modes to ensure ease of transfer between travel modes.

Lindau et al (2010) insist that based on the Curitiba's BRT system the concept of "*Integration*" goes beyond transport modes but it must also include the creation of synergies between urban mass transit and land development.



Figure 3-14 Integration of Rail (Tram) and Bus Services in Bern, Switzerland

Source: (<http://citytransport.info/Nondhtml.htm>)

In South Africa, the CoCT has chosen this model and is in the early phases of implementation; although currently the functional portion of the MyCiti[®] IRT is essentially a BRT Network. This PT alternative places an emphasis on integration of a selection of mass transit modes and speed(CoCT, 2012).

3.13.10 A Comparison of BRT Systems and Operations

The value of BRT/BHLS to urban mobility is directly related to the improvements in the operational performance of the road-based public transit they offer. In view of the performance parameters and criteria outlined in the previous sections, a number of studies have sought to measure and compare the performance of different BRT implemented BRT/BHLS systems. The reason for the comparison is to highlight best practice in the implementation and operation of improved bus services (Hidalgo and Carrigan 2010).

However, survey of literature, highlights two main challenge in comparing BRT/BHLS systems. These challenges are in the context of implementation and degree of inclusion of BRT components. There is currently no established standard for BRT systems or a common definition. Model systems such as Curitiba and TransMilenio have managed to achieve exceptional performance specifically in capacity and speed, making them competitive options for urban mass transit as compared to metro or LRT. Hence, their specific design characteristics and guiding policy have been duplicated around the world especially in developing countries' urban, as is seen in the case of Cape Town's MyCiti and Johannesburg's Rea Vaya IRT.

Despite the inherent divergence in the contextual application of BRT and scale of implementation (corridor versus city wide), there have been efforts to address this gap and set some common benchmarks. The BRT Standard Version *1.0* was compiled as a pilot project by the ITDP in 2012 and finalised into "BRT Standard 2013" to this effect. It can be described as an appraisal toolkit consisting of a set of design and performance criteria which can be used to assess planned or built BRT systems respectively. It ranks bus system as Gold (highest aggregate scores above 85 points) ,Silver (70 - 84) or Bronze (below 70 points) .

Nevertheless, it is noted that when using the BRT Standard for evaluating bus system performance that it implicitly favours the full specification BRT model and does not account for contextual issues such as levels of demand on a corridor (Hook et al., 2013).

Two other alternatives for evaluating a bus system performance and designs are identifiable from literature. Their approaches are either based on direct assessment of the performance outcomes or criteria like those described in Section 6.6 (measured for built networks and predicted for proposed systems) or on the financial productivity of a particular system (Hidalgo and Carrigan 2010) (D. Hensher, 2006).

Overall, common themes emerged in analysing literature comparing bus systems and transport systems in general. Most bus/PT system comparisons focus on three key areas:

1. Bus Priority Treatments
2. Operational Procedures such as fare collection techniques
3. Cost and Financial Viability

The above key areas are assessed by evaluating the degree of inclusion into the BRT/BHLS and their specific performance outcomes such as speed or cost. Authors agree that despite the performance indicators and costs of a PT system there is "no single" transition solution that universally applies to

improving urban mobility in all urban areas. This means that to fully understand the meaning of the performance indicators of a system evaluation, the results must be related to the precise mix of BRT/BHLS elements used to address the needs of the local market, the physical restrictions and, financial and policy objectives of a location.

Based on commonly accepted performance indicators and the recommendations made in the newly formulated BRT Standard 2013; the Table 5-3 below outlines the systems around the world with particular attention to the Latin American BRT systems. The results presented in the table are mainly based on findings from the work of Dario Hidalgo (Hidalgo and Carrigan 2010), Arno Kerhof (Kerhof and Soulas 2011c) and Transport Research Board (2003).

Table 3-3 Comparison of Selected Key Indicators of BRT/BHLS Systems around the World

Location	Scale	Capacity (ppd)	Commercial Speed (km/hr)	Capital (\$M/km)	Operational Productivity (boarding per bus-km)
Latin America					
Curitiba RIT	City Wide network of 65 km BRT corridors	13,000	19	2.5	-
Bogota, TransMilenio	Extensive Network of 84 km of BRT corridors	43,000	28	12.5	5.1
Sao Paulo, Interligado	A 104 km mix of partial and full BRT corridors	20,000	18	3.5	2.1
North America					
Pittsburgh, Pennsylvania	Radial Network consisting of 25 km of busways	4200	48	26 (avg. consists of three corridors)	≈12.0
Asia					
Janmarg, Ahmedabad	18 km of full BRT corridors.	1780	24	2.4	5.1
Beijing BRT (2005)	16 km of median bus lanes	8,000	21	4.8	6.3
Europe					
Trans Val de Marne, Paris (TvM)	20 of busways (95% are dedicated lanes)	1,200	23	9.5	-

Stockholm Bus Network	40 km of bus lane(30% DBL)	≈2,100	15 - 18	1.0	-
Amsterdam, Netherlands	14 km (70 % DBL including bus tunnels)	≈3,100	35	8.5	-

The above table highlights the applicability of the BRT/BHLS concept to a broad range of urban scenarios and the difference in results achieved. The results represent marked improvement over the conventional PT bus operations and service quality in the respective cities especially in terms of speed and reliability (Hidalgo and Carrigan 2010). It is these outcomes that compelled countries like South Africa to explore and consequently duplicate, model BRT systems such as Bogota's Transmilenio. In fact the one of the accessibility objectives of South Africa's PTS (2007) is an exact replica of Transmilenio Public Policy Objective as summarised by Enrique Penalosa (Bogota's incumbent Mayor in 2001): "...85% of the city's population will be within 500m of Transmilenio". The BRT or IRT systems as commonly referred to by the MAs in Johannesburg and Cape Town, represent the initial phases of implementing this model of mass transit into South Africa.

3.14 Public Transport Systems and Infrastructure in South Africa

Public Transportation or Transit (PT) refers to a transport service in which passengers share the given transit mode. It is typically available to the public and scheduled, although this is not always the case i.e. unscheduled public transport is called paratransit.

Alternatively, PT is often treated as a logistics problem in some academic spheres; hence in that light can be described as a set of activities that act together to convey people from points of trip origin to locations of desired destination in a cost-effective manner, according to Daganzo (1995).

According to the NLTA (2009): "public transport service" means a scheduled or unscheduled service for the carriage of passengers by road or rail, whether subject to a contract or not, and where the service is provided for a fare or any other consideration or reward, including cabotage in respect of passenger transport as defined in the Cross-Border Act, and except where clearly inappropriate, the term "public transport" must be interpreted accordingly.

It is important to recognise that the provision of public transport can either be formal or informal depending on the evolution of the transport sector in a country or region. Therefore, in the South African context the two sectors of PT operate parallel with each other i.e. their respective operations do not deliberately complement each other due to a difference in modus operandi (Salazar Ferro, Behrens, & Wilkinson, 2013).

3.14.1 Implementation of BRT in South Africa

The South African Experience with BRT is best illustrated by the first two systems to be implemented. The construction of both systems was accelerated by South's Africa's bid to host the World Cup 2010, as

the lack of high quality mass public transport was acknowledged. There are least 5 other BRT/BHLS in different phases of development in major and middle-sized South African Cities.

Table 3-4 show that the BRT concept had varying degrees of success in the cities of Johannesburg and Cape Town. The Rea Vaya system was recently award Silver Status by the Institute of Transportation and Development (ITDP) according to the BRT Standard 2013.

Table 3-4 Comparison of Selected Key Indicators of South Africa’s First BRT/BHLS Systems

Location	Scale	Capacity (ppd)	Commercial speed (km/hr)	Capital (\$M/km)	Operational Productivity (boarding per bus-km)
South Africa					
<i>Rea Vaya</i> [®] , Johannesburg	40 km of BRT corridors fully operation	≈40,000	20	3.7	-
<i>MyCiti</i> [®] , Cape Town	1 BRT corridor of 30 km fully operational and other more recent feeder routes	6000(literature) -11,000(CoCT official statistics)	22(calculated)	≈ 6.0	-

However, as with the previous comparison, the indicators are fully representative of the actual situation. While the Johannesburg BRT system continues to steadily expand its trunk-feeder network i.e. now entering its Phase 1B of construction, Cape Town’s IRT is lagging in number of ways. This is can be attributed to a number of factors including process of formalising the current taxi operators into service providers for the MyCiti IRT .This process of public transport industry transformation is a fundamental requirement of the PTS(2007) .

3.14.2 Inclusion of BRT Elements in South African BRT Systems

Cape Town's MyCiti and Johannesburg Integrated Public Transport Network (IRTPN) are essentially replicas of premier BRT systems such as Bogota's TransMilenio and Curitiba's RIT. This means they include all BRT five basic elements such as:

1. **Dedicated and marked Running Ways:** There is has been extensive use of exclusive use bus lanes with median placement in both systems, as Figure 3-16 shows below.



Figure 3-15 A section of Cape Town's BRT along the R27 during construction (CoCT,2012)

However there has been a focus on DBL as the primary means of providing bus priority with little use other alternatives such signal priority. According to literature reviewed ,this is also similar case on established Latin American Systems such as Transmilenio and Curitiba (Barker, Alvarez and Barnes 2003).

2. **Intersection Treatments:** *bus priority* treatments at intersections are a focus of this investigation. According to the 2012 MyCiti Business Plan, the only other bus priority measure used at intersections is Pre-signals (See Section 6.5.1.4 "Pre-signals") and the decision was made not to ban right turns across the median DBLs, to lessen disruption to general traffic. This design specification allowing right turns has been documented as being hazardous to pedestrian movement(Barker, Alvarez, Barnes, et al., 2003b).However, the use of specialised bus phases has been observed by the author especially on intersections of the IRPTN corridors within the Cape Town Central Business District (CBD).

Despite embodying many if not all the components of a BRT system, local authorities insist that these systems are to be integrated with existing public transport infrastructure and modes such as rail and NMT as envisaged in the PTS. There is a practical example of this integration in Johannesburg's Gautrain Rapid Rail Link which also has a distinct BRT feeder service with an estimated daily ridership of 12,000 passengers (2012 estimate).

The literature continually indicates apart from traffic congestion, that traffic signals are the leading cause of delay and travel time variability especially for scheduled bus services. Traffic Signals are said to account for 10% – 20% of bus travel times and 50% of delays (Kim et al., 2012) (Barker, Alvarez, Barnes, et al., 2003b). The key challenge remains that as BRT/BHLS operations expand into arterials such as Cape Town's Klipfontein and Lansdowne Road, which are heavily developed i.e. additional of lanes to allow for bus lanes may not be practical for many segments of these main arterials. This road space management and capacity issue makes them prime candidates for use of alternative bus priority measures such as BSP and queue jumps.

3.15 Public Transport Modes and Infrastructure

Transport infrastructure forms all the physical components of the transport system. This section deals particularly with public transport infrastructure and technologies associated with common mass transit modes. Rodrigue et al (2006) defines transport modes as the means by which people or units of freight achieve mobility.

Public Mass Transit (PMT) systems refer to technologies used to move large groups of people in urban areas. The essential feature of mass transport is that it allows for a group of people to be carried in one vehicle such as in a bus or a set of attached or guided carriages such as trains. They form the basis of any functional public transportation scheme.

3.15.1 Placement of Bus Priority Measures

All priority measures identified in literature can either be found along bus routes or at intersections. Section 5.2 will focus on detailing and illustrating configurations of physical PT priority measures. Figure 3-17 “Elements of a Road Cross-section” shows the typical parts of the Right-of-Way or Road Reserve. The basic premise of all priority schemes is they allow buses to, make movements prohibited to other traffic, give preference to lanes with PT flow or give priority to buses when detected via a particular ITS system (British Department of Environment Transport Government and Regions, 2001).

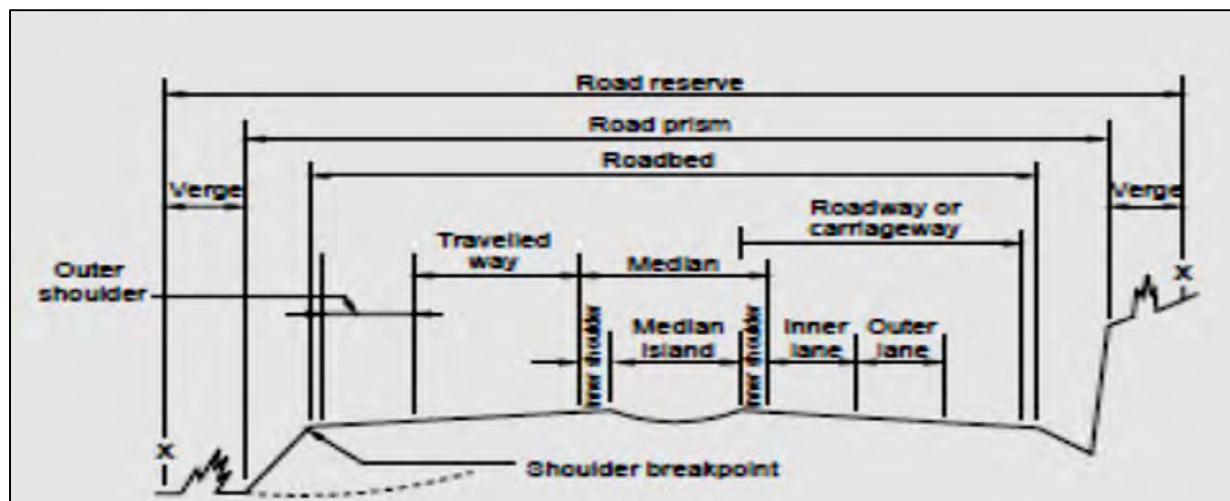

Figure 3-16 Element of a Road Cross-section (CSIR, 2005)

The proportion of road reserve made available to PT modes like BRT by excluding general traffic, determines whether it is regarded as a strong or light PT priority from an infrastructure point of view. A number of factors determine the level of preference given to PT i.e. mixed flow or separation from traffic.

There is a congruency in literature with regard to the tendency of physical PT priority to reduce road capacity for other traffic modes (Zhu, 2010) (Eichler and Daganzo 2006). The ITDP in the BRT Planning Guide strongly advocates for the use of DBLs particularly median DBLs on BRT systems by stating that allowing other high occupancy modes to use the bus lanes leads to congestion and reduction in operating speeds (Wright and Hook 2007).

3.15.2 Bus Ways

Busways are also referred to more generally as running ways in some literature. The terms are to mean a road or portion of a road that is designated for the movement of public transport vehicles and in some cases emergency vehicles. The degree of exclusive use, length along corridor, lateral guide and duration varies according to system specifications and locations (Eichler and Daganzo 2006) (Barker, Alvarez, Barnes, et al., 2003b).

This section will chronicle the on-street running type's i.e. bus lanes that operate at-grade. A number of cities like Brisbane (Australia) have grade separated busways but the high capital costs and permanent disruption to communities make a prohibitive option for budget constrained authorities (Miller, 2009).

3.15.3 Bus Lanes

These road lanes are characterised by road markings and unique colouration schemes as illustrated in Figure 3-18. The most common form of bus lanes observed in and around in cities including Cape Town is the “With- Flow” Bus lane ,this means that other permitted vehicles, such as emergency vehicles can use the lane(s) (British Department of Enviroment Transport Government and Regions, 2001).



Figure 3-17 An example of a Bus Lane as used In London, England.

The operations of bus lanes be can set to peak daily periods only or all day. Overall bus lanes have been shown to improve bus speed and reduce delays between stops but the need for *setbacks* at intersects can cause delays as other vehicles enter the bus lane to either transverse the intersection or to make a turn.

The other weakness of bus lanes is they are usually designed to minimise impact on general traffic at intersections rather than give preferential treatment to buses (Waterson, Rajbhandari, & Hounsell, 2003).

3.15.4 Intermittent Lanes

Ordinary bus lanes can become under-utilised and inefficient parts of the urban road network during daily periods of low service frequency, often at the expense of relatively higher inter-peak private car flows.

In view of this, the concept of the Intermittent Bus Lane (IBL) was introduced to address situations when it is not possible to convert road sections into fully DBLs and to bus routes which have consistently low frequencies during specific periods of the day(Zhu, 2010)(Eichler and Daganzo 2006).A possible execution of this concept is illustrated in Figure 5-3 “An implementation of a Peak Direction Intermittent Bus Lane” below.

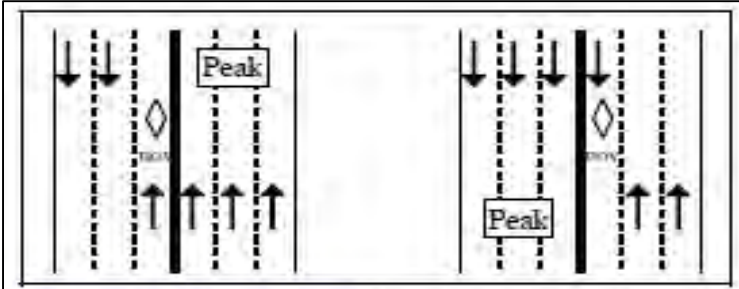

Figure 3-18 illustration of a Peak Direction Intermittent Bus Lane

Contra-flow lanes are another type of road intermittence which is widely used in North America in cases where the road reserve is inadequate i.e. cannot accommodate traffic flows for all modes (Miller, 2009). They allow buses to move in a direction opposite to general traffic i.e. non priority modes. Figure 5-4 shows a typical contra-flow lane configuration:

The contra-flow lanes have the distinct advantage of being self-enforcing due to the easily recognisable difference in direction of movement of buses along it. However, *concurrent flow* bus lanes often have to contend with disruptions arising from parked cars (legally and illegally) and incursions by drivers who violate the bus lane restrictions (Miller, 2009).

3.15.5 Dedicated Bus Lane (DBL)

A Dedicated Bus Lane (DBL) can be defined as a priority PT lane for buses physically segregated from mixed traffic by curbs, rumbles strips, guide rails or other barriers. Many at-grade bus ways are in the median to minimise conflicts with turning vehicles at intersections, but they can also be elevated or below grade (Hidalgo and Carrigan 2010). Some authors or field experts term any diversion from full physical separation of bus flow from general traffic as merely a HOV lane. This type (DBL) of running way is called a closed system because only authorised vehicles i.e. BRT buses can use it (Wright and Hook 2007).

A range of placement configurations of DBLs are possible and have been used in practice. Figures 3-20 and 3-21 including Figure 3-18 and 3-11; show common DBL placements that have been used and proposed respectively.



Figure 3-19 Median Busway Placement



Figure 3-20 Curb side Bus way Placement

For each of the above placements and configurations there are further variations in terms of specific operations. For example median lanes multiple or single lanes for bi-directional flow of buses as illustrated in Figure 5-6 below.

A survey of literature from different geographical shows sets the optimal DBL width at least 3.5 meters and recommends that sufficient space should be provided in running way to allow for overtaking of stopped buses especially at bus stops. This has implications in terms of available reserve and required space (ideally $\approx 15\text{m}$ per direction)(Wright and Hook 2007)(Lee et al., 2007)(British Department of Environment Transport Government and Regions , 2001).

There are a number of safety and design issues associated with DBLs that literature highlights especially with regard to conflicting movements with existing traffic on corridors (Kittleson and Associates et al,2003).For example *left turning buses* in median DBLs may be impeded by concurrent traffic flows if steps are not taken to protect that given movement. There is a need to protect the unconventional movement patterns which are associated with the introduction of bus lanes. This can be done by channelization and modification of traffic signal timings and addition of phases.

3.15.6 Bus-Only Street or Bus Malls

A bus-only street is usually a road that is closed off to all forms of vehicular traffic apart from buses. They are also referred to as bus malls and are often pedestrianised to promote accessibility (British Department of Environment Transport Government and Regions, 2001).

Bus malls are often only applicable in very particular circumstances or situations. They are practical in areas of the city with high PT demand and can provide ease of access to attractions such as shopping centres. There are a number of good examples in several locations including a portion of the MyCiti™ (Cape Town's IRT) along its Table View Corridor, as shown in Figure 5-10 below.



Figure 3-21 the Bus-Only portion of the Cape Town IRT system

Source : <http://www.ilovewoodstock.co.za/2011/08/the-woodstock-myciti-bus-terminal/>

The strategic enabling factor for the Table View route was that the system designers were able to convert a disused section of railway into a bus way. This is also unique example of the urban regeneration abilities of implementing of BRT in a South African context.



Figure 3-22 An Example of A Bus Mall And Related Signage

Source:(British Department of Environment Transport Government and Regions, 2001)

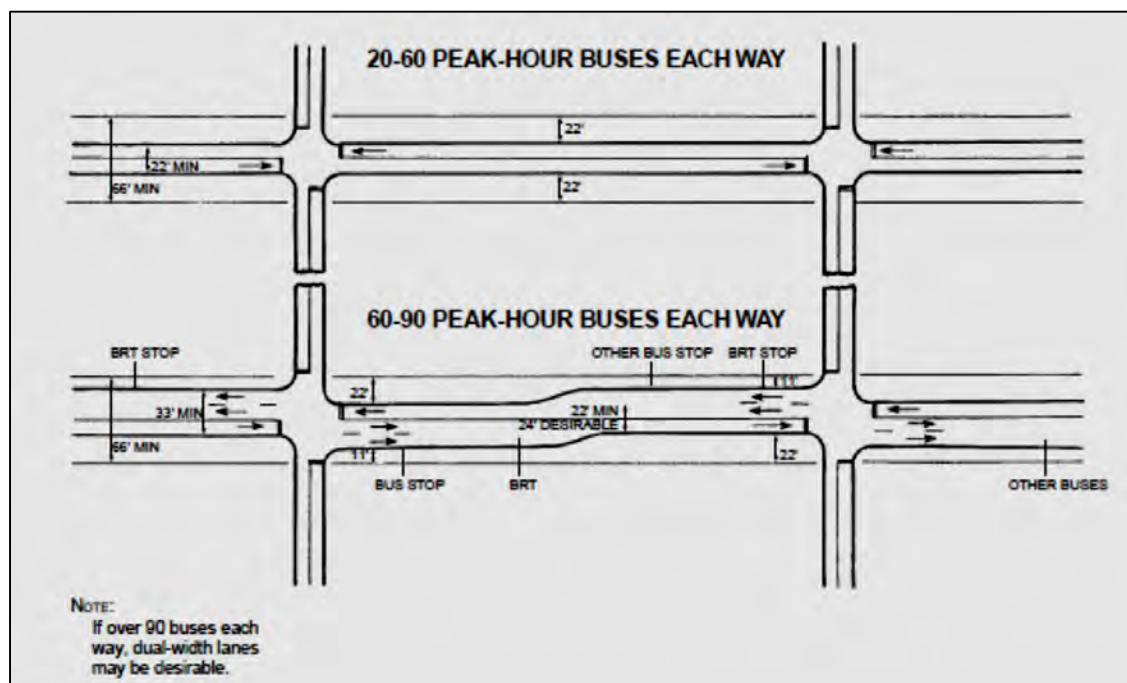

Figure 3-23 Some Typical Bus Street/Mall Designs(Barker, Alvarez, Barnes, et al., 2003a)

It is continually noted from literature sources that the intended frequency of a given IRT is a major determining factor in the appropriate sizing of facilities and right-of-way requirements. The implementation of bus malls must also account for the given urban social and economic context(Barker, Alvarez, Barnes, et al., 2003)(Lee et al., 2007).

From the above examples it is noted that bus malls are effectively a distribution mechanism for bus based IRTs. Overall, they can serve to establish PT serve identity and improve reliability of service in portions

of the PT corridor which run through CBDs or activity hubs of this nature (Barker, Alvarez, Barnes, et al., 2003).

3.15.7 Special Road Geometry Considerations

This section provides background and information of more localised priority treatments that are in use in various municipal jurisdictions and have shown ability to reduce bus travel times and increase reliability. From the literature surveyed these schemes are commonly used to complement other more conventional priority strategies.

3.15.8 Shoulder Running Lanes

A shoulder running is a practice of allowing buses to use arterial or freeway road shoulders to by-pass traffic congestion. Hence, in American literature it is often referred to as Bus By-pass Shoulder (BBS). The following urban transport jurisdictions ; Maryland, Minnesota, Virginia, Washington, British Columbia and Ontario, have shoulder running schemes implemented (Lee et al., 2006).



Figure 3-24 BBS And Road Marking Along Washington State DOT SR-522(Lee et al., 2006)

Time savings in the range of 5 – 15 mins have been reported from freeway shoulder schemes. Customer perception of these time savings is an added benefit due to increased bus trip time reliability and schedule adherence. Some users have mentioned that it helped reduce their stress which results from waiting in the traffic congestion (Lee et al., 2006).

The BBS has the ability to by-pass bottle necks and give buses priority passage through traffic hot-stops, hence, using it as a “queue jump” especially near intersections, has been strongly suggested.

3.15.9 Queue Jump Lanes

A queue jump lane (QJL) is typically implemented by the addition of a lane near an intersection in the order of 30 m to 100 m in length depending on intersection traffic dynamics. It is reserved for buses so they by-pass the congestion or accumulated queues at a given junction.

The QJL effectiveness is maximised when used in conjunction with bus signal priority [*BSP*] (refer to next Section 3-18). The synchronisation of BSP with QJL is critical not only to reduce transit times but also to ensure safe merging of bus(es) with mixed traffic flow in a case where a DBL is unavailable downstream of signal (Barker, Alvarez, Barnes, et al., 2003a).

Figures 3-25 and 3-26 illustrate the aforementioned concepts as presented in literature.

Figure 3-25 Typical Queue Jump Lane Designs

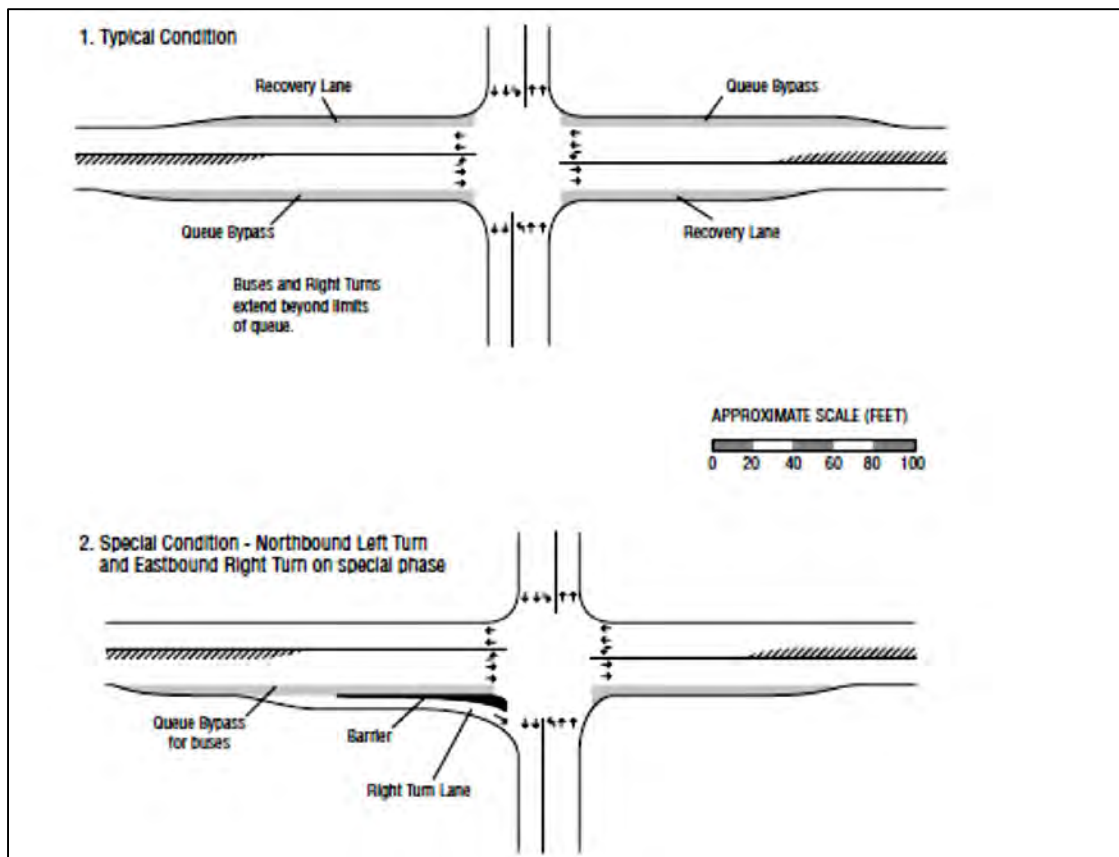

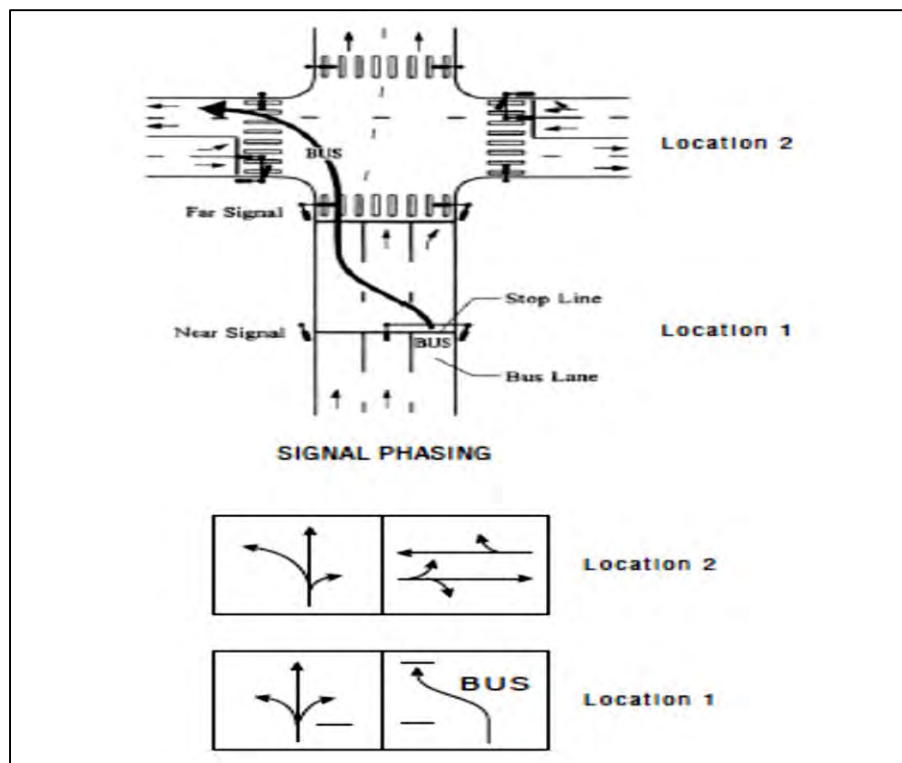

Figure 3-26 An Example Of An Execution Of A Queue Jump Lane And BSP Phases.

3.15.10 Bus Signal Priority (BSP)

BSP is a traffic signal control strategy that reduces bus delay at signals by maximising the green time for the PT lane or movements. BSP has been shown to lower travel delay for PT vehicles and cars travelling in the same direction.

The magnitude of delay reduction ranges from 2% to 18% in running time operations (Lee et al., 2007). This is supported by data from previous studies exploring the suitability of BSP measures in variety of urban contexts. Hounsell and Shrestha (2004) who reported delay reductions of up to 12.5% per veh per cycle (derived from results presented in). A summary based on information from the Bus Transit Capacity Manual ((Kittleson and Associates) et al. 2003) on the reported effectiveness of different BSP strategies is presented in Table 2-6 below.

Table 3-5 Effectiveness of Typical Bus Priority measure at Signals

Bus Priority Measure	Bus Travel Time Reduction
Bus-activated BSP	Up to 10%
BSP	3-15% of travel and and 75% in signal delay
Bus Signal pre-emption	Up to 20% and up to 90% in signal delay
Queue Jump	5- 25%
Curb Extensions	Insufficient data
Boarding Islands	Insufficient data
Stop Location Optimisation	3 -20% in cycle times 75% in dwell time

Intersections are critical points along any BRT corridor and, since BSP occurs mainly at intersections, these points of the PT corridor will also be a focus of this study (Wright and Hook 2007).

However, the use of BSP is not without its disadvantages. The early implementations of BSP in North America were based on *signal pre-emption* strategy which gives unconditional priority to buses, as is commonly the case for trains at railway-road intersections. This strategy posed a threat and safety hazard to other movements such as pedestrians, and a number of studies have seconded these findings ((Kittleson and Associates) et al. 2003).

Overall the uptake of BSP measures is relatively slow and corridor specific due to a lack of understanding of its operations ,design and optimisation (Kim et al., 2012) ((Hounsell and Shrestha 2004). This is despite the fact that technologies for deployment have been in existence for over 40 years, particularly pioneered in European countries like Britain.

3.15.11 Pre-signal

A pre-signal is a type of BSP which gives buses priority access to an upstream bus advance area .This is to help avoid traffic queues and congestion on the immediate intersection. Signal delay reductions of up to 5% have been reported in literature based on the basic design scheme presented in Figure 3-32.

**Figure 3-27** Non-Priority Control Pre-Signal General Layout



Figure 3-28 A pre-signal in use along the R27 corridor of MyCiti Phase 1

Source: (Chitauka, 2013)

Pre-signals have proven to be helpful in situations where the road reserve is insufficient to provide queue jump lanes and also to facilitate maximum use of active BSP measures at upstream intersection

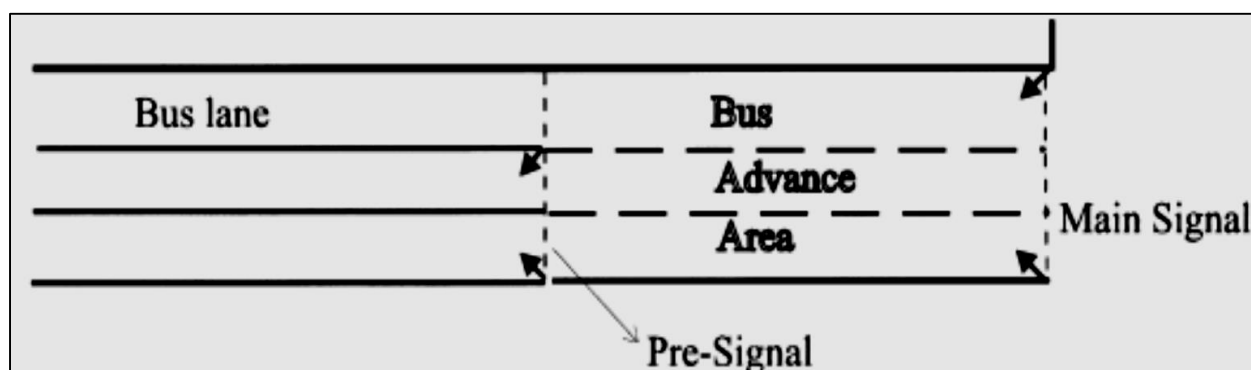
3.15.12 Brief Overview of Traffic Signal Plan Design

The Highway Capacity Manual is one of the most comprehensive and widely used guides in Traffic Engineering practice. In Chapter 16 of HCM the design of signalised intersections is explained.

The design of a given intersection traffic signal timings is primarily based on the following inputs:

- Road Geometry
- Signal Control
- Traffic Conditions

3.15.13 Application of BSP

According to literature, there BSP can be divided into three categories namely Passive, Active and Adaptive Signal Priority.

3.15.14 Passive Priority (PP)

This is a set of BSPs which is implemented by integrating strategic or historical knowledge about the bus operations details such as dwell times, to adjust area-wide and isolated signal plans for the benefit of bus transit. PP does not necessarily require specialised equipment or software for priority request detection.

Examples of PP measures are: phase splits to introduce bus phases, corridor schemes to facilitate preferential bus progression and phase lengthening in favour of bus passage at intersections.

3.15.15 Active Priority (AP)

Active Priority is a set of traffic management strategies that give priority to a particular type of vehicle based on a process of priority vehicle detection and priority activation. The most basic and implementations are Green Extension (GE) and Red Truncation (RT) which are also called Early Green. This concept, and an indication on how they can be applied, is shown in Figure 3-27 “BSP Concept Pie-graph”.

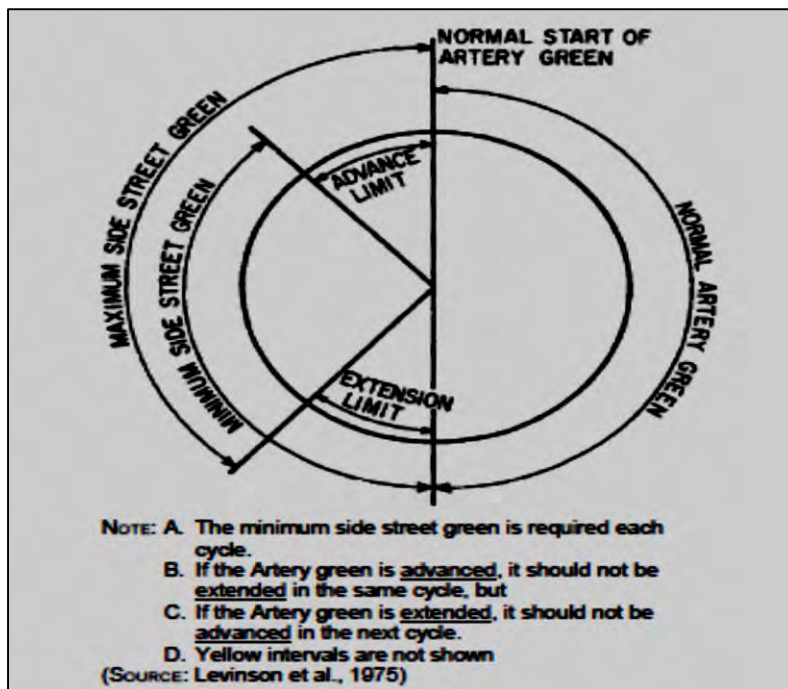

Figure 3-29 BSP Concept Pie-graph

Green Extension works by extending an existing green phase to until a PT movement is completed. This implies that the PT vehicle is detected within a given green phase and this makes it highly effective since it eliminates additional delay from clearance which is required to execute a *Red Truncation* priority request.

Red Truncation is a priority strategy which shortens the red phase to return to green phase for a specific PT movement. This occurs typically when the bus is detected within a red phase. This concept is also illustrated in Figure 5-16 below:

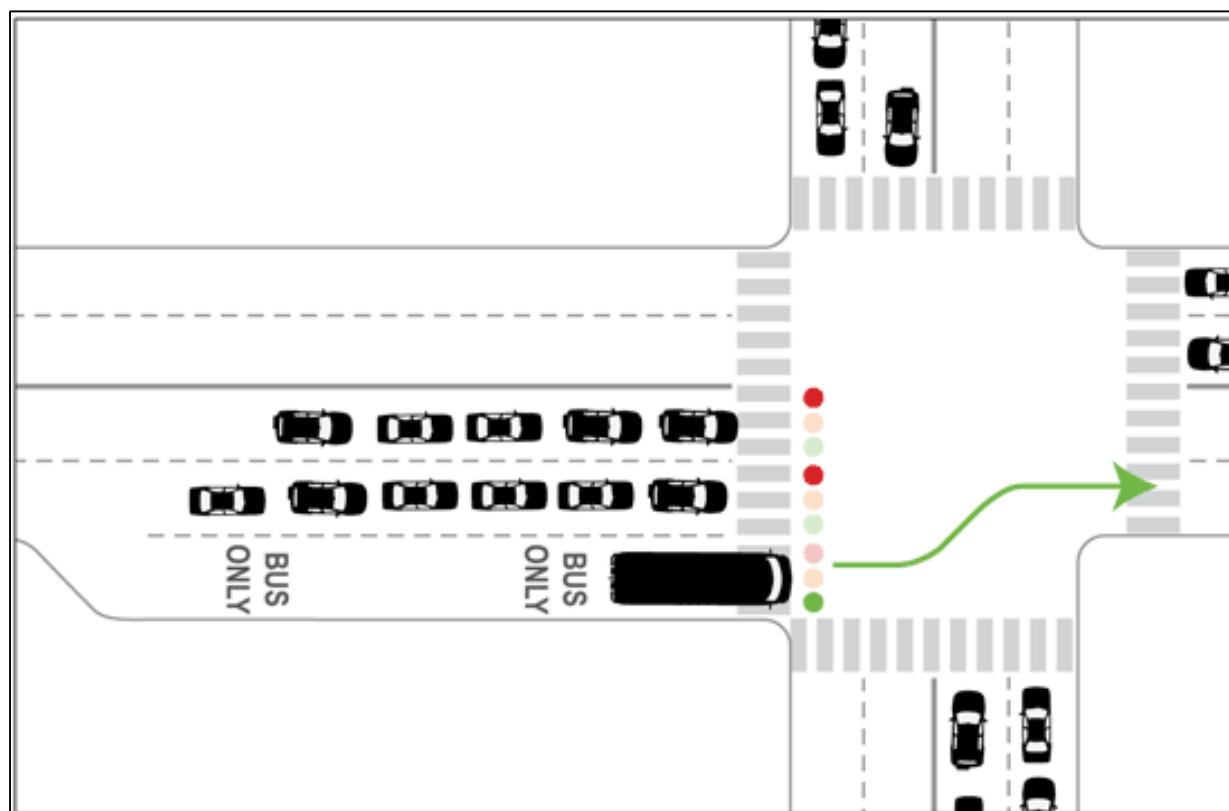

Figure 3-30 BSP Green Extension and Red Truncation Concept

Source: <http://www.mto.gov.on.ca/english/transit/supportive-guideline/creating-complete-streets.shtml>

Active priority strategies' effectiveness is significant when integrating ITS technologies like Automatic Vehicle Location (AVL) and real time monitoring. These technologies can allow BSP to operate on a conditional basis because the actual degree of priority required by a bus can be determined by considering its schedule or lateness.

Furthermore, relatively simple PT vehicle detection technologies can also allow for more novel Active BSP strategies such as *phase insertion* whereby a PT phase is only added when a bus is detected, hence changing the signal timings accordingly.

Table 3-6 Typical Conditions Which Make Intersection Suitable For BSP

Parameter	Effective Range	Feasibility
LOS	LOS C - D	Yes
V/C Ratio	0.8 -1.0	Yes
Bus headway	2.5 – 3.0min	Yes

In order to understand the effectiveness of a given BSP it critical to study the traffic dynamic at an intersection level rather than a network level. Previous studies have tended to focus on a network level(Albright and Figliozzi 2012). It is the author’s aim to use microsimulation to evaluate these dynamics.

3.15.16 Applicability of Transport Priority Schemes to South African Urban Areas

This section presents an outline of complementary bus priority measures that have been extracted from literature and have potential for application in South African urban settings. The bus priority measures are selected on the basis of similarity in infrastructure, ease of installation and reported effectiveness.

3.15.17 Bus By-Pass Shoulder

The nature of urban development along portions of Klipfontein and Lansdowne road can be used as test beds for Bus By-pass Shoulder as described in Section 3. In figure 3-28, a pictorial comparison is made between a sections which is similar to an already existing BBS lane in Washington State, USA.



Figure 3-31 Lansdowne Road Shoulder near Jan Smuts Road, *Cape Town* intersection (courtesy of Google Maps) and a BBS in Washington State, *USA*(Lee et al., 2006).

3.15.18 Pre-emption

While the PTS (2007) specially calls for bus signal pre-emption priority measures to implement for IRT systems in South Africa, literature indicates that current best practice has moved away from this strategy. This is due to its potential to cause considerable disruption to general traffic and danger to crossing pedestrians. While many factors influence urban transit services, delays induced by the operation of traffic signals typically account for 10%–25% of the total travel time of buses (Sunkari et al. 1995) (Dion, Rakha, Asce, & Zhang, 2004)

For example portions of Klipfontein and Lansdowne Road has been found to have the worst pedestrian fatality rates, this means that PT along these corridors must include intermodal safety mechanisms and considerations.

3.15.19 Signal Coordination

The potential for this is possible from the geometry of the proposed Klipfontein PT corridor due to the high number of crossing streets of varying vehicle flows and traffic patterns. This can be viewed as a passive priority measure and, if executed correctly, may use existing signals with minor adjustment and optimisation.

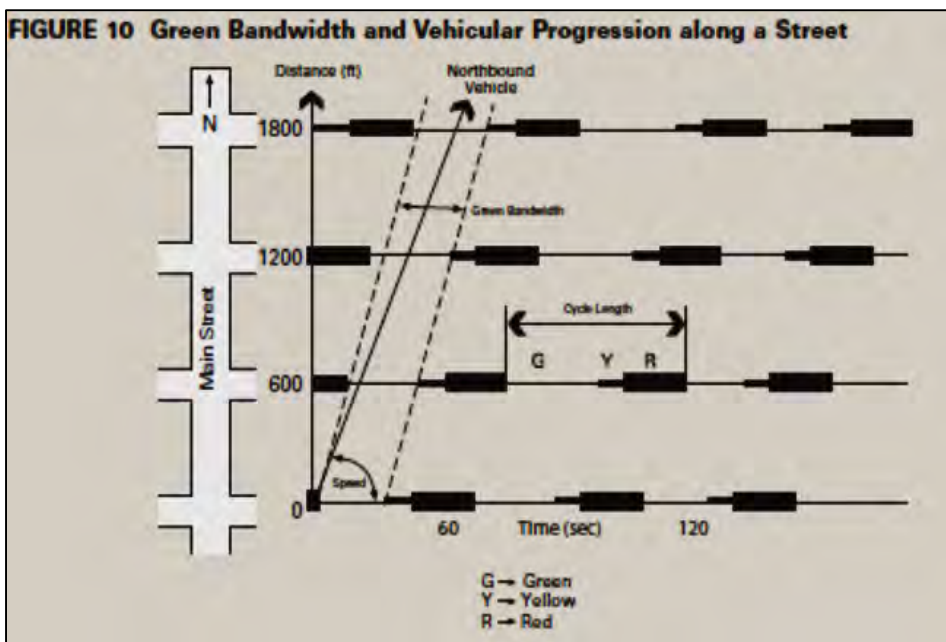

Figure 3-32 Signal Progression

Note the high intersection densities i.e. most are less than 500m apart and signalised in Figure 3-31 below.



Figure 3-33 Klipfontein Road Corridor (near Athlone Stadium)

3.16 Financial Considerations in Public Bus Systems

The agency costs can be defined by the financial expenditure required to provide a public transport service and infrastructure. These costs can be further divided into two core groups namely; initial or capital and operating cost. They are abbreviated in literature as capital and operating expenditure i.e. CAPEX and OPEX respectively. According to Lee *et al* (2007), the CAPEX and OPEX associated with a BRT/BHLS is dependent on the following aspects of BRT elements:

- Scale of Application of BRT element
- Number of BRT elements used
- Policy objectives

The CAPEX and OPEX are typically sourced from government and user fares which may be subsidised in some cases. Hence, the fare forms the direct cost link between the PT system operations and passengers. The Generalised Cost of Travel Formula provides a means to assess the different aspects of travel cost to the agency and passenger as explained.

3.16.1 Generalised Cost of Travel

The generalised cost of travel is a way to quantify the effectiveness of key components of a transport system in relation to user convenience which is difficult to measure objectively. The BRT Planning Guide (2007) provides the following equation for computing the generalised cost of travel:

$$GC = \alpha IVT + \beta WTM + \delta WAT + \epsilon TMM + \gamma NTR + \rho FAR \quad \text{Equation 3-6}$$

Where the abbreviations mean the following:

IVT = In Vehicle Time

WTM = Total Walking Time to and from bus stop

WAT = Waiting Time for bus(es)

TTM = Total Time taken for Transfers between PT modes/routes

NTR = total number of transfers required per trip

FAR = Fare paid by user. The coefficients α , β , δ , $\epsilon\gamma$, and ρ are the weightings assigned to each term in the equation 271 above.

According to Wright and Hook (2007), the generalised cost equation is a good starting point to assess a new or proposed improvements to bus PT will be. Therefore, the generalised cost of a given route can be computed for, before and after scenarios; then compared. The unit outputs for this would be in bus minutes.

3.16.2 BRT Cost Framework

This section will focus on the CAPEX component of BRT costs as this accounts for most of the expenditure associated with constructing the right-of-way and related enforcement infrastructure. Comparisons of BRT/BHLS systems in literature like the TRCP Report 118 consistently indicate that the road pavement construction account for up to 50% of the BRT CAPEX. Therefore any innovation or alternative measure to replace or reduce the extent of applying this element is likely to produce marked reductions in CAPEX and maintenance costs.

Figure 3-34 below shows a breakdown of capital cost of Cape Town's BRT system in different stages of its implementation. The trends that emerge from the figures are typical of full-feature BRT systems .i.e. the initial stages require intensive financial investments in right-of-way acquisition, construction of segregated road way infrastructure and pavements. The acquisition of right-of-way can prove costly and challenging especially in areas of section of transit corridors that well developed and therefore had limited road reserve to accommodate road widening. This often adds to costs and further delays as seen below during the initiation phase of BRT over 60% of the costs are accounted for by road works and land acquisition alone.

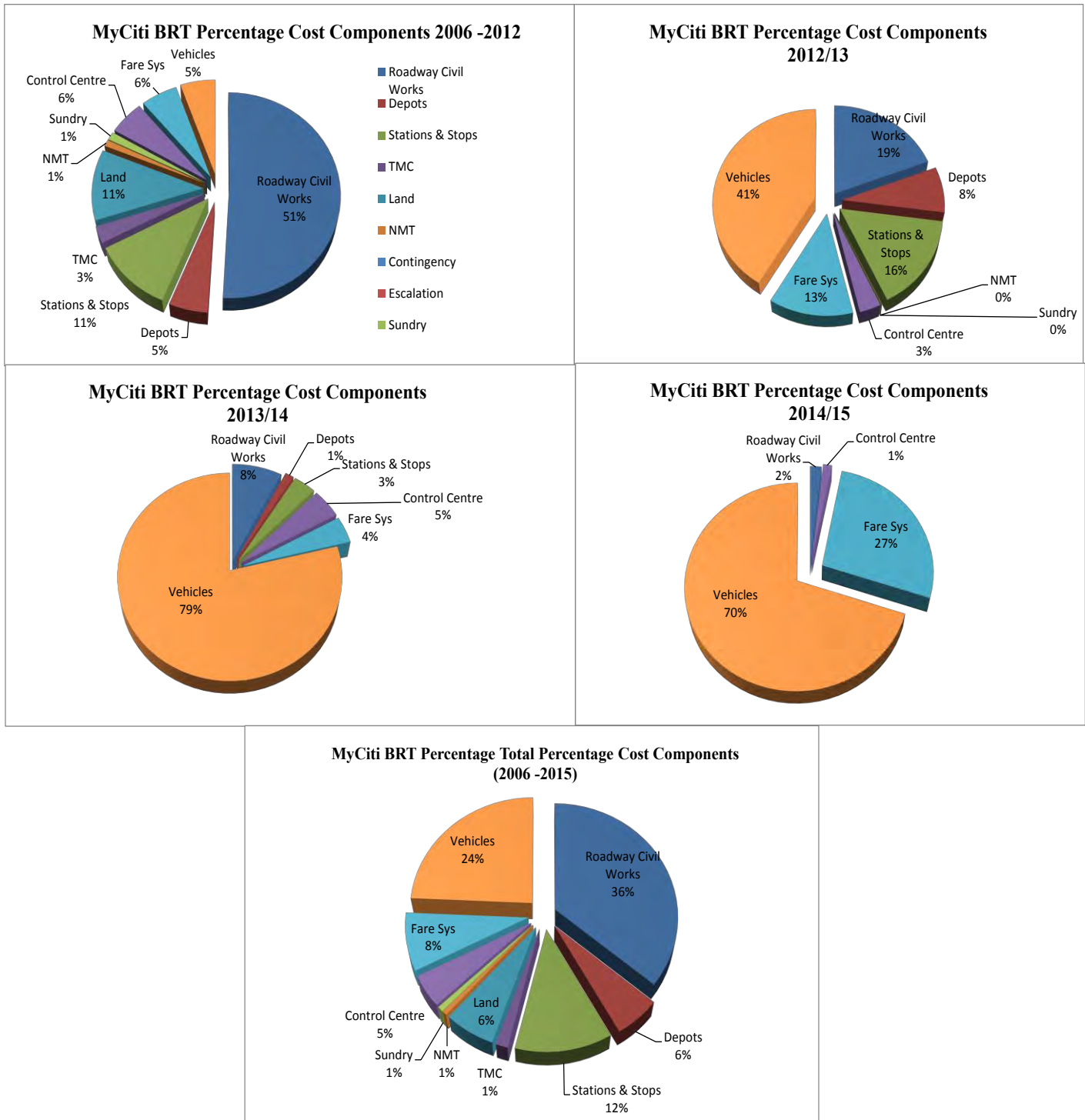

Figure 3-34 Percentage Costs of key BRT Elements as calculated from the MyCiti Business Report

3.16.3 Current Cost Framework Based on Cape Town Data

The underlying assumption made by Lloyd Wright and Walter Hook (2007) in their authoritative text the “BRT Guide” are not fully applicable in a South African context. The reason for this disjuncture is that the BRT/BHLS data presented in their text focusses on operating costs because it assumes that physical infrastructure such as dedicated bus lanes are the sole responsibility of the national government. This approach tends to produce favourable costing results for BRT systems but excludes the major component of CAPEX which is the construction of right of ways as shown in Figure 3-33 above.

In South Africa, the road names are an indicator of the sphere of what government is responsible for i.e. maintenance and upgrade. This means that on-going maintenance of improvements such as dedicated bus ways that will be on urban corridors like; Klipfontein and Lansdowne designated **M18** and **M9** respectively, fall under the municipal authority’s jurisdiction. The use of specialised pavement material and markings suggests this will be more costly than ordinary roads hence any schemes to reduce the need for strong transit priority measures, such as DBLs, is likely to make BRT a more financially sustainable and viable option for MAs.

3.16.4 Time Value in Cape Town: “the cost of delays”

Another important aspect in the costing and cost-benefit of public transport improvement interventions, such as DBLs and TSP, is its link to economic value of time. This implies that the reduction in travel delays can be translated into a cost saving (ZAR) provided there is a quality data relating to the cost of operating PT and delays.

The literature yielded little information about the current cost of public transport operators and impacts of traffic delay and congestion on their operations particularly in Cape Town. In view of the lack of reliable academic discourse on this matter, some operations cost data was obtained from Cape Town’s main PT bus operator i.e. GABS. Based on the data provided, it was established that it currently costs GABS **R27/bus-km**; to provide a PT service which covers over 1000 routes throughout the Cape Town Municipality. It is this data that can be used to give an indication of the cost saving that can be achieved by different PT priority schemes due to anticipated reductions in travel delay. According to Vuchic (2007) reduction in time/delay causes exponential gains in productivity.

3.16.5 Synthesis of Literature Review

The key messages that emerged from this literature review discussed below:

There is clear definition of what full BRT is. This definition states that a bus system must have the following characteristics to be classified as BRT (Wright & Fjellstrom, 2003):

- Exclusive busways utilised on trunk-line corridors
- Pre-board fare collection and fare verification
- Closed stations with verified entry only to paying users
- Entry to system restricted to prescribed operators under a reformed business and administrative structure (“closed system”),
- Clean vehicle technology
- Fare free integration between feeder services and trunk-line services

However, in principle there is no clarity from literature on what BRT is not. According to Lloyd *et al* (2007) any bus system that does not have all features of a full –feature BRT is referred to as merely an improved bus system or BRT-lite. For countries that adopt this PT method, there appears to be a fixation on application of the full BRT model in lieu of local context. The available evaluation framework for BRT system further reinforces this somewhat bias approach(Hook et al., 2013). Tracing ,the public transport policy of South Africa over the past decade, illustrates that many developing countries are forced to align their provision of PT to conform to full BRT model rather prioritises the individual needs of communities that need improvements in public bus performance and provision (as reviewed in Section 3.7).

Transport policy defines the direction and basis of public transport provision in a country. In South Africa, the policy supports the supply of quality public transport service through Integrated Rapid Public Transport Networks (IRPTN) but to date all the systems deployed are effectively full feature BRT systems which have limited integration to existing public transport systems. This can be viewed as a sign that these systems in their current form are well not adjusted to the existing social, economic and spatial contexts of most South African cities.

Priority schemes such as BRT have drastically improved the performance of urban bus services around the world and South Africa. The challenge that remains ;is going beyond these pilot phases of deploying full feature BRT systems (full BRT), expansions of these networks into arterial corridors with limited road reserves cannot accommodate the extensive infrastructure associated with full BRT. Additionally, full BRT /strong priority measure are relatively more costly associated with their construction and maintenance. However partial bus priority methods such as BSP and bus queue jumper lanes offer less infrastructure and cost intensive methods of improving public bus performance. Literature indicates that the effectiveness of alternative /partial priority schemes have been demonstrated in many North America and Asian countries like South Korea(Barker, Alvarez, Barnes, et al., 2003).

Overall, the literature reviewed all concur that public transport systems like public bus services that are functional, swift and efficient are the most sustainable option for providing mobility to rapidly increasing urban populations. The wider economic benefit or positive externalities of enhanced bus services justify

the need for buses to be prioritised over lesser private vehicles especially during peak hours on major urban arterials. Therefore, the main issue of contention is on the methods of providing this priority to public bus services.

4 Methodology

4.1 Modelling Traffic Systems

Modelling is the process of mathematically or graphically representing a dynamic physical or real world system. In the field of transport engineering and traffic planning: static or dynamic traffic models are used to predict or assess the performance of transport infrastructure. According to Vanderschuren (2006), traffic modelling is a tool that helps support decision-making; which is part of an overall transport planning process.

This chapter aims to concisely describe the traffic model concept and use of microsimulation software in this case PARAMICS to simulate public transport operations such as BRT.

4.2 Fundamental Theories of Traffic Modelling

The basis of traffic modelling is the four (4) step model. This is a fundamental principle applied on a range of modelling scales. The scales of traffic modelling are Sketch Planning, Macroscopic, Mesoscopic, Microscopic and Nanoscopic. The aforementioned list is given in order of increasing detail and data input requirement. Figure 4-1 shows the scales of traffic modelling relative to their appropriate planning horizon.

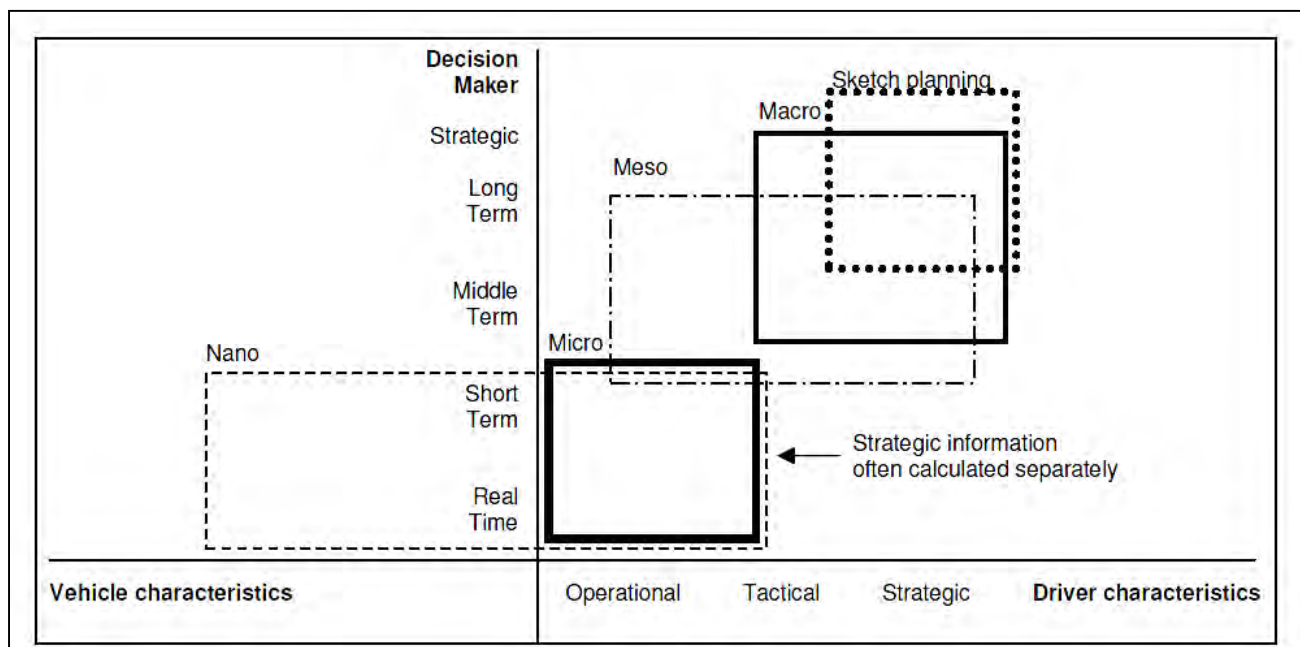

Figure 4-1 Scales of Traffic Modelling and Transport Planning Horizons (Vanderschuren, 2006)

The model category most relevant to this investigation is the microscopic traffic simulation also referred to as microsimulation. This because it has the ability to describe the movement of individual vehicles and pedestrians in relation to:

1. Road infrastructure and geometry
2. Some ITS measures
3. Other vehicles.

The above make microsimulation a good approach to modelling traffic dynamics especially to anticipate and access traffic flows after hypothetical or proposed changes to road infrastructure and control systems are applied (Treiber, Hennecke, & Helbing, 2000) (Vanderschuren, 2006).

4.3 The Classic Transport Model

The classic transport model refers to the four (4) step model which is actually a general framework which all or most transport models follow irrespective of scale. It consists of four steps namely; Trip generation, Trip distribution, Modal Split and Route Assignment.

1. **Trip generation:** This is the first step of the traffic modelling process. It involves the counting or calculation of the number of trips that are associated with each specified traffic analysis zone (TAZ). Similarly, 15 zones were generated for this study in the model.
2. **Trip distribution:** Takes the number of trips generated and distributes them between the TAZs which results in set origin-destination pairs. The collection of these pairs is called an O-D Matrix (see section 5.2.1 for OD Matrix development).
3. **Modal Split:** This requires knowledge of the traffic composition of a study i.e. percentage vehicle type. Most public transport improvement seeks to alter an area's modal split by attracting users from less efficient modes. For urban areas in South Africa, the private car is the most common mode i.e. greater 50%.
4. **Route Assignment algorithm:** In this step all trips which are mode defined are allocated along different routes according to assignment algorithms. Some common route assignment methods are *all or nothing*, *capacity constraint* and *multiple routing*.

4.4 Mathematical Theory Underlying Microsimulation

A number of mathematical and analytic theories have been formulated to describe traffic flows and individual vehicle motion; especially beginning from the early 1950s. There are some key behaviours that a given mathematical equation must emulate to simulate individual vehicle movements at different time intervals. These vehicles basic behaviours as explained by *Wu (2001)* include:

- **Car following:** microsimulation models describe the longitudinal motion of vehicles by assuming a response –stimulus relationship particularly between vehicles within a lane. It seeks to reflect

the reality that acceleration and deceleration of a leading car will cause; those behind it to adjust their movements accordingly. This response stimulus relation can be expressed generally as shown in Equation 4-1 below :

$$\text{Response} = \lambda \text{ Stimulus} \quad \text{Equation 4-1}$$

Where: λ is a sensitivity coefficient.

The trio of *Gariz, Herman and Rothery* developed one of the early car following equations which also called the General Motors Car following Equation where $a(t)$ is acceleration of a car in lane.

$$a(t) = c \times v(t)^m \times \frac{DV(t-T)}{[DX(t-T)]^l} \quad \text{Equation 4-2}$$

Where v is the speed of the vehicle, DX is the separation between the vehicle under consideration and preceding vehicles, DV is relative speed and ' c ', ' m ', ' l ' and driver reaction time T are user determined constants.

4.5 Lane Changing and Gap Acceptance

Lane changing and merging are a key set of vehicle behaviours that traffic microsimulation and nanoscopic models have to simulate in order to reflect realistic traffic movement. Gap Acceptance has been identified as the main parameter which determines these lateral vehicle behaviour such as lane changing (Vanderschuren, 2006) (Zohdy, 2009). Figure 4-2 “an illustration of lane changing terms”.

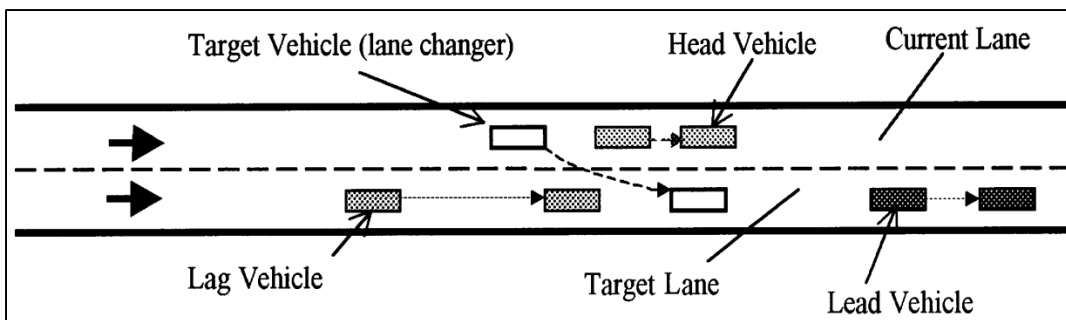

Figure 4-2 an illustration of lane changing behaviour terms

The gap acceptance is usually measured in time (seconds) in literature reviewed and closely related to the concept of headway. Zohdy (2009) states that there are two distinct situations in which gap acceptance applies which are (1.) *Crossing movements gap acceptance* such as right-turning movements at intersections and (2.) *Merging gap acceptance* as is the case at an on-ramp.

The accurate modelling and adjustment of parameter or coefficients is vital to ensure that intersection capacities and volumes can be deduced with acceptable confidence. The Figure 4-3 shows that the inverse relation size of the gap acceptance and opposing flow rate.

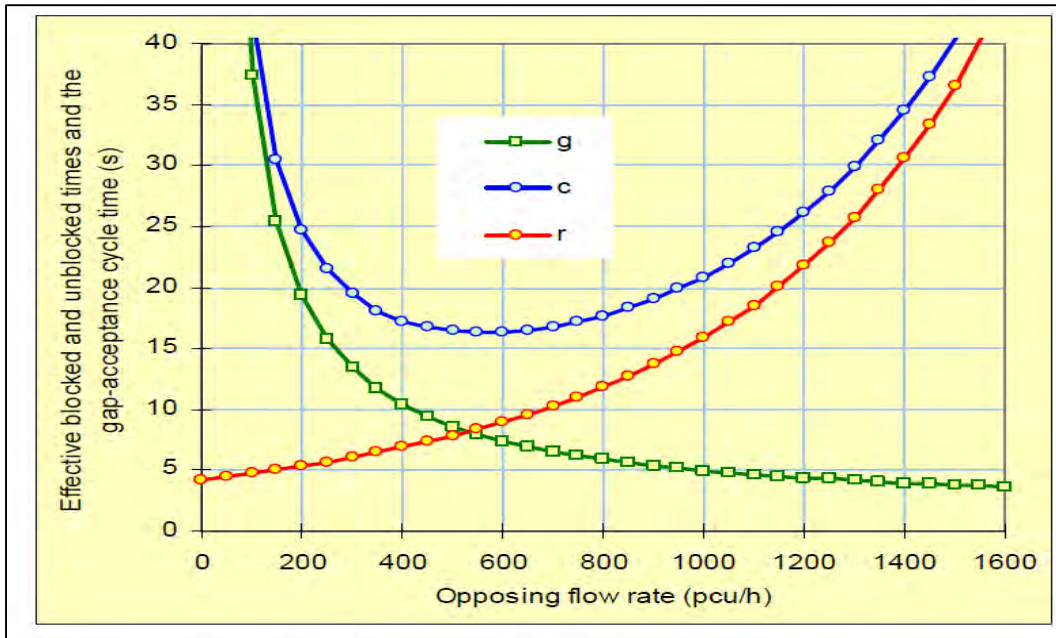

Figure 4-3 Gap Acceptance-Rejection Time Vs. to the Opposing Movement Especially at Intersections (Akçelik, 2011)

There are a variety of mathematical equations used to describe the lateral vehicle motion in literature. However most models are either deterministic or stochastic i.e. include a probabilistic distribution to account for the viability in driver reaction to similar situations. The Equation 4-3 below; shows a typical mathematical model of gap acceptance with a stochastic component (Mathew,2012)(Vanderschuren, 2006).

$$G_n^{g,cr}(t) = \exp[X_n^g(t)\beta^g + \alpha^g v_n + \sum_n^g(t)] \quad \text{Equation 4-3}$$

$G_n^{g,cr}$: Critical gap measure for gap G perceived by driver n at time step t

$X_n^g(t)\beta^g$: Explanatory variable used to characterise mean $G_n^{g,cr}$.

$\sum_n^g(t)$: Random term follows log normal distribution α^g = parameter of the driver specific random term v_n . Assuming $\sum_n^g(t) \approx N(0, \sigma_z^2)$ i.e. the critical gap lengths are log normally distributed.

In general a mathematical model like Equation 4-2 is linked to a probability distribution to determine the likelihood of a driver completing a manoeuvre based on the calculated critical and individual characteristics, such as driver aggression, which are usually accounted for in most commercially available microsimulation packages, including PARAMICS.

The deterministic methods as described in the *Highway Capacity Manual* (HCM, 2010) are based on empirical formulas derived from extensive field measurements and observations under but under North American conditions. They are practical but limited in scope of application and prediction because they are macroscopic in scale.

4.5.1 Queuing and Bottlenecks

Mathematical methods from queuing theory are useful to describe congestion at bottlenecks in a network. A bottleneck can be defined as a location which has a maximum capacity or throughput due to some limiting i.e. in the context of this study road intersections are viewed as bottlenecks, as their capacity is determined by the signal delay and road geometry. This is generally observed as queues form on urban arterials particularly at locations such as intersections. This implies that demand exceeds capacity especially during peak hour on these particular roads. According to Saito (2004). The inputs to a queue calculation and analysis are as follows:

1. Mean arrival value
2. Arrival distribution (generally to accepted to be random .e.g. Poisson process)
3. Mean service value
4. Service distribution
5. Queue discipline (FIFO, FILO, etc.)
6. Number of service channels available (can usually be taken as one for each lane group).

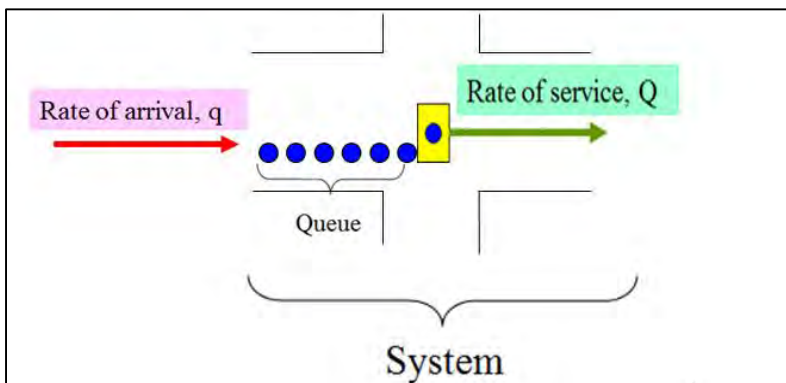

Figure 4-4 An Idealisation of a Queue Formation at a Road Intersection (Saito ,2004)

The key assumption for use of the queue theory system under analysis is under-saturated or below capacity i.e. $q < Q$.

The following equations are used to calculate:

the probability of n units in a system (intersection) given by Equation 3-3:

$$P(n) = \left(1 - \frac{q}{Q}\right) \left(\frac{q}{Q}\right)^n \quad \text{Equation 4-3}$$

Where n is the number of buses or cars.

The expected number of units at a given intersection can be determined by Equation 3-3 while the mean length of the queue is given by Equation 3-4:

$$E(n) = \frac{q}{(Q - q)} \quad \text{Equation 4-4}$$

Some mathematical expressions for determining basic queue characteristics are presented above Saito (2004). It is noted that proprietary microsimulation implementations use similar approaches but the specific expressions may vary depending on the programming platform used and assumptions made.

4.6 Analytical Methods

The Highway Capacity Manual (2000) provides an extensive range of analytical methods for computing the operational LOS and capacity of various road elements and transport infrastructure. The methods used in the HCM are widely used in transport practice around the world especially with regard to the following traffic aspects:

1. Signalised and unsignalised intersections
2. Public transport infrastructure i.e. lanes, stops, transit priority
3. Road Corridor Analysis particularly road segments 3).

Despite providing a good estimate, it remains limited since its methods are static i.e. can only show the operational conditions of a road element or section at a single point in time; thus cannot show how conditions change over a time interval such as during peak hour(s) (Zohdy, 2009). A review of literature shows that researchers are continually refining analytical methods for specific traffic conditions and transit aspects to improve accuracy of results (Hotel and Rouge, 2003)(Clifton and Rose, 2013)(Skabardonis and Christofa, 2011).

Overall, literature sources indicate that analytical methods are useful especially to obtain feasible initial estimates and to provide a basis for comparison with more dynamic methods like microsimulation. However, it becomes evident that the computation effort required to obtain results for traffic scenarios beyond single elements is tedious. In fact, for the method of corridor analysis in Chapter 29, HCM actually recommends use of Excel spreadsheets instead of hand calculations.

4.7 Microsimulation of Traffic Systems with PARAMICS

The microsimulation of traffic modelling was used to simulate the interaction of public transit modes and general traffic along the case study corridors. A commercial software package called Quadstone

PARAMICS was used to execute this step of the investigation. The primary objective of the process was to implement a working base model which could then be modified to simulate possible priority schemes.

The main differentiating of microsimulation models is that individual units or agent can modelled and their individual decisions within a constrained /ruled based environment can be described. Hence, the name agent-based microsimulation models. This makes them suitable for modelling and predicting the response of agents to changes in corridor operating conditions such as traffic signal plans, road geometry or even congestion.

The process of simulation was carried out in eight (8) sequential steps. The steps are listed and explained below:

4.7.1 Steps of Execution:

1. **Case Study Selection:** the study area and reasons for selection are explained in detail in Section 1.
2. **Data Collection and Area Reconnaissance:** Four types of data were collected. These are the intersection traffic counts, traffic signal timings, peak travel speed and travel times along corridors. Due to limitations in resources traffic signal times and counts were only conducted at 3 critical locations. The locations and technology used to collect the specific data type are summarised in Table 4-1 below:

Table 4-1 Categories of Data Reviewed and Collected

Location(Intersections)	Data Type	Technology
Klipfontein + Jan Smut Road	Traffic Count	Manual Counts
	Signal Timings	Video Camera
Lansdowne + Jan Smuts Road	Signal Timings	Video Camera
Duinesfontein + Lansdowne Road	Signal Timings	Video Camera

The video data obtained was further analysed to determine the exact phase allocation for movement more accurately. Furthermore, a set of loop counts was obtained from the Traffic Management Centre located in Goodwood, Cape Town. The loop counts consisted of data from 2007, 2010 and 2012 for some different road segments i.e. erratic due to faulty or vandalised loops. The average travel speeds and travel times were determined by driving along the corridor during the peak interval 7h00 to 9h00 on two different days (Tuesday and Thursday) of the same week.

- 3. Road Network Coding:** This step was executed with the use of Google Maps. A scaled background image was generated using Google Earth. This was to ensure that the distances used by the simulation calculations were correct. Based on the test measurements the mapped features were correct to within 1m. The network model features relevant to the investigation were drawn using the Designer Module of Quadstone PARAMICS i.e. selected links, traffic signals and bus stops.
- 4. Input of Data into Model:** The collected data, such as signal timings were input directly using the signal control module of the software. However, the traffic counts and loop data were used to create an O-D matrix that reflected the real world situation. Given, that no known microsimulation study this detail has been done on the corridor, there was no external point of reference apart from iterative validation with available data.
- 5. Simulation Model Testing:** In this stage, the model was tested by running it using the default setting i.e. no randomisation default seed #6) was used. The aim of this step was ensure that the network components and behaviour were realistic and identify serious errors such as unconnected links and blocked intersections (signal timings all set to red). A few errors were identified and rectified.
- 6. Network Audit and Validation:** Parameters such as vehicle mixes (modal splits), were adjusted to reflect the latest available data from the CoCT. Further, runs were completed to refine the O-D matrix, especially with regard to link volumes and mean speed. The validation process was based primarily on the loop data which had provided modal split and volume for given segments along Klipfontein and Lansdowne Roads. It was relatively more reliable and hence the O-D matrix was adjusted until the model outputs were within an average of 20% deviation from the observed data (loop counts). Calibration is often the same as the validation process. A strict calibration is not possible because of the difference in levels of detail in available information (J. Wu, Brackstone, & McDonald, 2003). The validation was done by comparing the road segments under consideration with the corresponding loop section count.
- 7. Generation of Results:** The results were generated from the four main scenarios. The processor module of Quadstone PARAMICS was used to allow for multiple runs to be executed in a faster time. A set of 50 runs were carried out per session with randomly generated seeds, to simulate the intrinsic variability in inter-day traffic flows. These results were then averaged per scenario and then prepared for analysis.
- 8. Analysis of Initial Results:** The initial results extracted were assessed according to the MOEs described in Section 5.7. The focus was the outputs relating to: speed, travel delay, travel time and LOS which is linked to delay. This analysis will be extended to include indicators reflecting the user experience such as dwell times. Visualisations were then produced as part of the comparative analysis between priority scenarios and performance of public transit modes versus general traffic. Some results were obtained directly from the Analyser Module of PARAMICS while others had to be processed in a spread sheet.

Further to this error analysis was conducted on results that had a data set against which to validate i.e. the flow rates and speeds. Following recommended best practice, when the all results had been generated an Analysis of Variance (ANOVA) was completed in order to bench mark results from priority scenarios against the base case.

4.8 Microsimulation Modelling

The evaluation of literature and consultation with transport professionals helped the author propose five key scenarios, including a baseline scenario partly based on 2012/13 traffic data.

The results were generated from the five main scenarios. The processor module of PARAMICS was used to allow for multiple runs to be executed in faster time. A set of 50 runs were carried out per scenario and each scenario was from randomly generated seeds i.e. to simulate the intrinsic variability in inter-day traffic flows. These results were then averaged from all 50 runs per scenario and then prepared for analysis. As Figure 3-6 illustrates, the traffic operations and infrastructure in the study area were modelled accurately.



Figure 4-5 A Screenshot of an Intersection Geometry As Coded Into The Model

The main real world components of the transport system that were inputs and simulated are the: Traffic conditions, geometric considerations, Transit Operations and Signal Operations. The traffic conditions observed such as vehicles flows were focussed on the peak period 7h00 and 8h00 with an allowance for a 5 minute warm-up period. The bus transit operations were modelled with a 10 minute frequency and an assumption of all stop service

4.8.1 Modelling and Microsimulation of Public Transport Systems

The chosen microsimulation provided a method to carry out simulation of basic public transportation functionality. However, it did not have direct provision of certain aspects which were required for this investigation such as Dedicated Bus Lanes (DBLs), BSP and Mini-Bus Taxi traffic flow behaviour. In

order, to simulate these specific scenarios, the author formulated a number of proxies. The proxies are adjustments to the software parameters to better imitate the distinct movements' patterns of cars, mini-bus taxis and buses along the corridor in the microsimulation runs. The proxies are

The modelling proxies used are

- 1. Dedicated Bus (DBLs) and Bus Mini-bus Taxi (BMT) Lanes:** The Lane Attributes function in PARAMICS was changed to impose lane usage restriction either on the innermost (Median BRT) or outmost (kerbside BRT) lane depending on the scenario. In the case of BMT Lanes, a lane restriction applied to all vehicle types, except public bus modes and MBTs.

In addition to the above, the author created three main vehicle types namely BRT buses, Minibus Taxis (14-seater passenger vehicles) and cars (consisting of typical private types .i.e. sedans, coaches, light trucks etc. This differentiation between the vehicle types, allowed the lane restriction function to be applied. This meant that simulate segregated bus lanes were able to be modelled more accurately.

The key assumption when applying this simulation proxy was that there is 100 % compliance with lane restriction. This is realistic since the current DBL features raised kerbs to prevent illegal incursions into them.

- 2. BSP:** The vehicle actuated signals were modelled to mimic the operations of a National Electrical Manufacturers Association (NEMA) actuated signal control unit which are widely used particularly by Siemens Traffic Intersection control units. However, to simulate activation of bus priority by buses only, the detector loop length was adjusted to 6 meters to ensure that only the buses would be detected and activate the priority signal especially in scenarios where other vehicle types shared the same lane as buses.
- 3. Bus and Taxi Express Services:** As the Figure 3-6 shows, the station spacing and stopping sequence followed by a PT service has a considerable effect on its average operating speed. Hence, in order to simulate the behaviour of proposed express services (skip-stop operations), the software was adjusted to restrict the number of bus stops serviced by a given route.

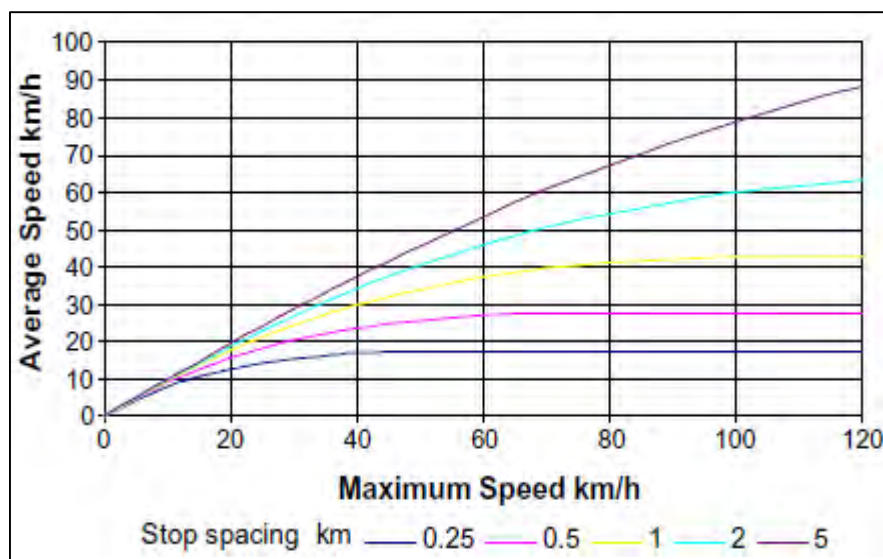

Figure 4-6 Effect of Station Spacing on Average Speed of Bus Service (Lee et al., 2007)

However, the relatively random patterns of stopping and dwell times, which are characteristic of MBT or paratransit operations presented a challenge to mimic. A solution was to specify that for the given PT vehicle type (in this case MBTs), passenger arrivals at pick up points were set to a random distribution and vehicles were coded only to stop if passengers were present at stops. This setting was consistent with typically observed behaviour of MBT and passengers i.e. passengers usually wait for MBT close to existing bus stops, although MBT may also collect other passengers at intermediate locations (illegal and dangerous stops manoeuvres).

4.9 Results Analysis Methodology

The results generated from the microsimulation method described in Section 4.8 were evaluated by statistical inference.

Statistical inference is divided into two major areas namely estimation and tests of hypothesis. A test of hypothesis method called the t-test was used. The main reason for selecting this method was its robustness i.e. no statistical parameter was estimated rather the results from the simulation model and site observations were used to make decisions relative to the stated hypothesis. On the other hand, estimation methods are better suited to research studies or investigation whose primary objective is to predict a parameter e.g. frequency, mean etc. of a given population based on calculated statistics or trends in a smaller sample.

As stated in Chapter 2, the main goal of this study, is to determine whether a certain set of alternative bus priority measures are as effective in; increasing mean bus speeds and reducing delays under South African conditions i.e. an urban arterial called Klipfontein Road (Cape Town). The effectiveness of these alternative priority measures was compared to the strong bus priority such full specification BRT.

The first step after selecting an appropriate statistical analysis method was to determine a null and alternative hypothesis. The following seven steps were followed:

1. Determination of the Hypotheses:

The null hypotheses were stated as shown below and the two alternative hypothesis were stated as directional statements to help answer the key research question:

H₀: partial bus priority measures = baseline scenario

H_a: partial bus priority measures ≥ baseline scenario (Speed) or H_a: partial bus priority measures ≤ baseline scenario (delay).

The null hypothesis indicates that partial bus priority measures equal to the baseline scenario therefore do not significantly improve public bus performance (speed & lower delay) along the Klipfontein corridor. Conversely, the two alternative hypothesis state that partial or alternative bus priority measure significantly improve bus operations by increasing the mean speed and reducing the mean travel delay.

2. Set-up of rejection/ acceptance criterion

An α - value of 0.05 was used .i.e. within the bounds of generally accepted levels of significance for quantitative research. This implied a 95% confidence level in the conclusions or decision made based on these t-statistic calculations. The importance of this statistic as applied in this analysis was to enable to author to determine if the differences in the samples or results from each scenario was significant .i.e. caused by the deliberate changes in simulated operating conditions or simply random variation. However, it remains to be said that based on the principles of a t-test, if given a duo of samples results was inconclusive or could not allow us to accept or reject the H_a, it would indicate that insufficient evidence to reach that conclusion rather than validate the H₀.

3. Calculation of degrees of freedom

4. Organise data into two columns

5. Use excel to calculate t-statistic based on step 1 - 4

6. Evaluation of t-statistic relative to set criteria in step 2.

7. Arrive at decision/conclusion

Therefore the guiding hypotheses were either accepted or rejected according the above criteria. It can be seen that the alternative hypotheses were supportive of the research question. .i.e. alternative or partial bus priority schemes can improve bus performance to the same degree that full priority schemes can. This means that that if the alternative hypotheses were shown not to be false; then partial priority measures offered local authorities an effective alternative to full BRT as a means to improve public bus performance in congested corridors.

5 Results and Analysis

The results of the microsimulation are presented in this section and grouped according to the aforementioned five (5) main modelled scenarios. However an additional two sub scenarios were modelled for Dedicated Bus Lanes (DBL); Median and Kerbside. All the modelled scenarios made the assumption of a mean 60-second dwell time, bus/PT lane, with turn delays, a 10 minute frequency and typical signal timing (except the one bus queue jumper (BQJ) and two BSP scenarios. Furthermore, a warm-up period of five minutes was allowed for, hence a simulation run-time of 60 minutes was used (excluding the first 5 mins) to mimic the 7h00 – 8h00 AM traffic peak.

5.1 The Modelled Scenarios

The scenarios are as listed below in order of analysis:

1. Baseline 2012/13
2. BMT Taxi Lane,
3. Bus Queue Jumper Lanes,
4. Dedicated Bus Lane Kerbside with BSP,
5. Dedicated Bus Lane Kerbside without BSP,
6. Dedicated Bus Lane Median with BSP and
7. Dedicated Bus Lane Median. without BSP

5.2 Model Set-Up

5.2.1 (Origin-Destination) OD Matrix Development

The OD Matrix used in this model was developed through trial and error. This method of trial and error was used due to the lack of reliable traffic count data across the study area. The final or validated OD matrix had a total 60,595 veh trips between the 15 zones. A copy the OD matrix has been attached to the Appendix (refer to Section 8: Appendix). A modal split of 66:34 for private vehicle to public vehicle was also used in all scenarios, this was based on the mean daily ratio 70:30 according to the City of Cape Town 2011 estimates.

The attached OD matrix was used because it allowed the model to output results that reflected observed field conditions along the simulated Klipfontein and Lansdowne corridors. The indicator outputs referred to here, are traffic flows (veh/hr) and travel time along the respective corridors. Table 5-3 shows that this approach produced modeled travel times with +/- 2% of the observed corridor journey times.

5.2.2 Scenario Development Summary

Table 5-1 shows the fixed and variable inputs used in the modeling exercise. It is worth noting that the same OD matrix was used in all scenarios, to allow for a valid comparison between scenarios. The main differentiator was the way lane restriction rules were applied between the different scenarios in the model. Secondly the model allowed for BSP was implemented by adjusting the default size of loop detector from 2m to 5m to ensure only buses (usually longer than 5m) were given signal priority.

Table 5-1 Variables and Key Parameters Used

Modelled Scenario	Input Parameter					
	Modal Split Car/PT	Total OD Trips Loaded (fixed input)	Minimum Frequency (bus/hr)	Lane Restriction	Signal Priority & Locations	PT Veh Detection
Baseline 2012	66/34	60,585	6	No	No	No
Bus Mini-Bus Taxi Lane (Kerbside)	66/34	60,585	6	Yes	No	No
Bus Queue Jumps	66/34	60,585	6	Yes (only intersections)	Yes	Yes
DBL Kerbside	66/34	60,585	6	Yes	Yes	No
DBL K+BSP	66/34	60,585	6	Yes	Yes	Yes
DBL Median	66/34	60,585	6	Yes	Yes	No
DBL M+BSP	66/34	60,585	6	Yes	Yes	Yes

The Baseline 2012/13 scenario represents the business as usual or status quo in line with standard modelling practice. Its output and indicators correspond to the observed traffic conditions in the study area (refer to Section 2.5) i.e. volumes, travel times, mean speeds and delays. All alternative scenarios were compared against it to assess the degree of effectiveness in improving selected indicators.

Secondly the BMT scenario simulated included the application of a 3.5 m wide lane reserved for use by buses and mini-bus taxis only i.e. assuming 100% compliance from general traffic. The BMT lane was modelled in along the 10 km segment of Klipfontein Road with the study area, between Jan Smuts Road and the Gugulethu/Philippi Golden Arrow Bus Depot. It was important to model this because South Africa transport authorities have already experimented with similar concepts in the form of HOV lanes along Ben Schoeman Highway (N1) between Johannesburg and Pretoria (Vanderschuren, 2006). Additionally, it is less likely to cause face opposition from the informal PT sector (MBTs) because it does not deviate from their current operations.

The Bus Queue Jumper lanes were the third scenario modelled. This scenario consisted of implementing bus queue jumper lanes ranging in length from 60 m to 100 m at 4 main intersections along Klipfontein namely; Jan Smuts, Belgravia, Vanguard and Duinesfontein. They were placed on the far side lane of the intersection and given an advance green signal. This scenario was considered because of the long queues observed exceeding 60 m or going until the upstream intersection during AM peak hour, particularly in the Westbound direction. Literary sources indicate that in most case BQJ lane do not impact intersection capacity negatively because they operate within the typical signal cycle settings (Lahon ,2011).

A BRT lane with median placement was the fourth scenario. It was modelled by placing one 3.5 m wide lane in each direction and restricting its usage to all modes except fixed route public buses. This scenario was developed to simulate a typical full specification BRT's traffic movements. This form of bus priority is recommended in the authoritative texts on the subject such as the BRT Guide (Hook et al., 2013)(Wright and Hook, 2007).Furthermore a variation of this scenario with BSP was tested and results noted.

Similarly BRT lanes with kerbside placements were implemented on the aforementioned segment of Klipfontein Road. A variation of kerbside placed BRT with BSP was also tested and its results recorded. Most public systems prefer this configuration due to the ease of access to bust ops by passengers among other local factors. In fact, some full specification BRT systems include segments with Kerbside operations due to site limitations. Additionally, many cities in the USA and Britain have this form of bus priority.

In all of the above scenarios the following inputs were the same; Origin-Destination (OD) matrix, traffic modal split and peak period i.e. AM Peak. The primary difference between the scenarios was the lane configurations to simulate the selected priority measures. This was done to ensure it was the main or key variable.

5.3 Baseline 2012/13 Scenario

Figure 5-1 “Baseline Scenario plot of Bus vs General Traffic Speed” reflects the current traffic conditions i.e. public bus and vehicle on the corridor during a typical weekly am peak hour. The most significant finding in this scenario was that, general traffic mean speed reduces exponentially as the traffic volumes increases in the network from reaching a mean speed of up to 35 km/hr but reducing to and remaining relatively stable at 7 km/hr (2km/hr deviation) for the last 30 minutes of the simulation period. The graph also show the drastic effect of traffic congestion on bus operations in that the general traffic mean speed forms an upper boundary for bus speeds i.e. bus speeds average 5 km/hr and decline to 3 km/hr during the last 30 minute interval but do not exceed the speed the congested mixed traffic is travelling at.

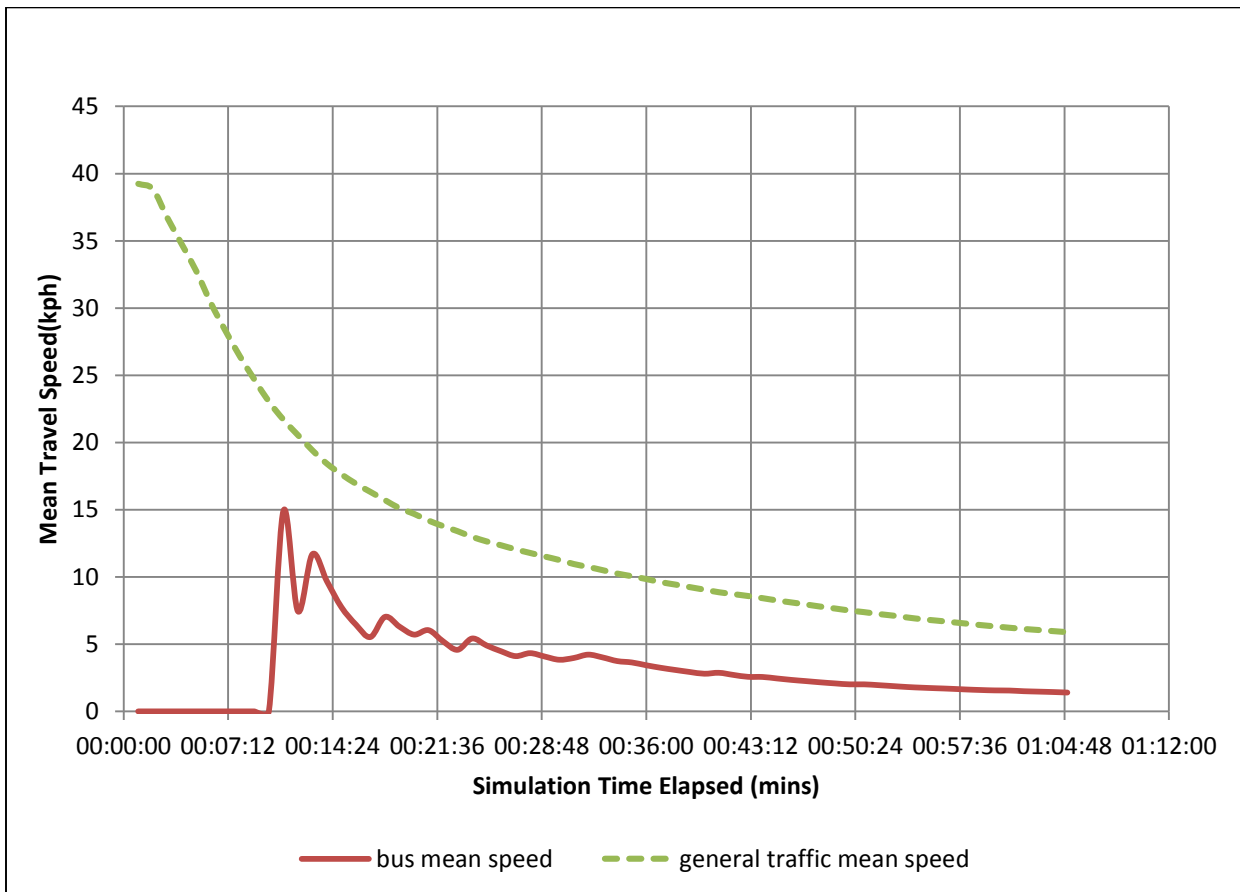

Figure 5-1 Baseline Scenario plot of Bus vs General Traffic Speed

Another interesting finding relating to the general traffic speed is that the mean travel speed under less congested conditions, halves every 10 mins before reaching equilibrium at 7 km/hr. This can be explained by the exponential nature of the speed's decay. This gives some insight the reason for unreliability of travel times during peak hours in congested urban arterials, i.e. because beginning a bus or car journey +/- 10 min can easily translate into doubling of travel time, because of the aforementioned speed travel.

5.4 Bus Mini-bus Taxi Lane Scenario

Figure 5-2 shows the results after a simulated BMT lane was implemented on the Klipfontein Corridor. The mean operating speed for buses is substantially improved i.e. it maintains a mean speed of above 12 km/hr for the first 30 minute interval, though a slight decline to 10 km/hr is observed as the network becomes more congested and there is a higher level of consistency in speed during the time interval. As seen from Figure 5-1 the general traffic speed also reduces exponentially. However due to this scenario buses speeds exceed that of general traffic and are able to maintain a mean velocity of 11 km/hr (2km/hr deviation) even as in general traffic speeds decrease in the second 30 minute interval of the simulated am peak hour. This observation indicates that the BMT lanes successfully allay public transport modes from hourly peak congestion by allowing them to maintain a consistent operating speed throughout the peak period.

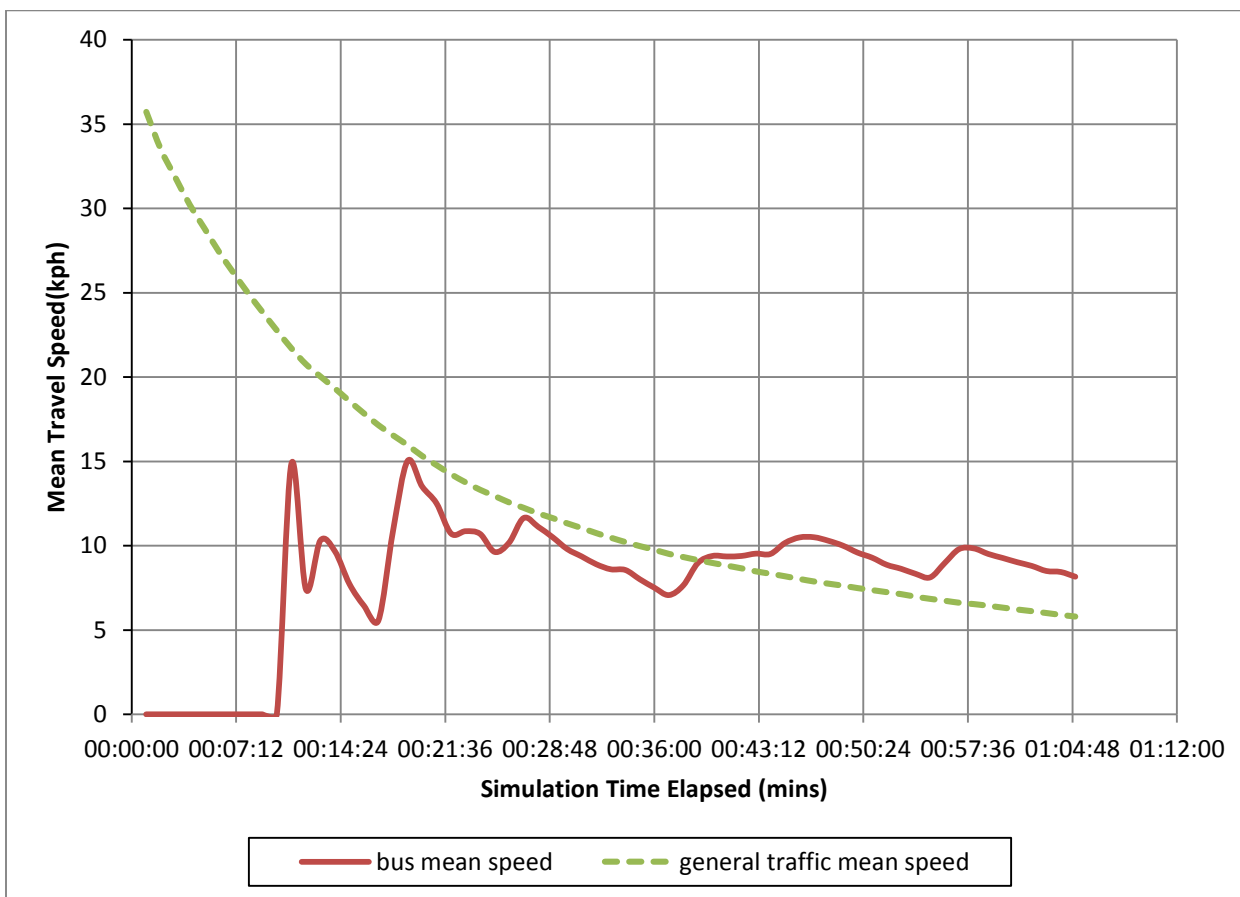

Figure 5-2 Bus Mini-bus Taxi Lane Scenario plot of Bus Vs General Traffic Speed

The speed of the bus is more robust in this scenario as evidenced by its relatively consistent speed. It is noted that during the mean speed the bus begins to decrease, particularly after 28 mins, which corresponds to the beginning of the typical 15 min critical period during the am peak. Although the public speed recovers after about 15 mins from 8 km/hr to 11 km/hr, it does highlight that despite segregation of MBTs and buses from general traffic it is still susceptible to effects of congestion, especially at major intersections. The general traffic speed is very similar to the base but the speed

declines at a marginally lower rate, in this scenario. This can inelasticity is explained by the effects of two counter acting measures i.e. restriction of MBTs which usually reduce arterial capacity by their movement patterns but at the same time, a lane was removed from general traffic to accommodate the BMT lane.

5.5 Bus Queue Jumper Lanes (BQJ) Scenario

In Figure 5-3; geometric changes in the form of bus queue jumps (typical 60 – 100m longs) were implemented at four major intersections along the corridor including Klipfontein-Jan Smuts and Klipfontein-Vanguard Roads. The logic of this priority is based on the observation of long queues (+60metres) at major intersection approaches. However, the BSP along the queue jumper lanes was only given to buses since the baseline indicates they are the most adversely affected transport mode. This was accomplished by setting the detector loop size to be 5 m i.e. can only be activated by buses which have typical lengths in excess of 5 meters.

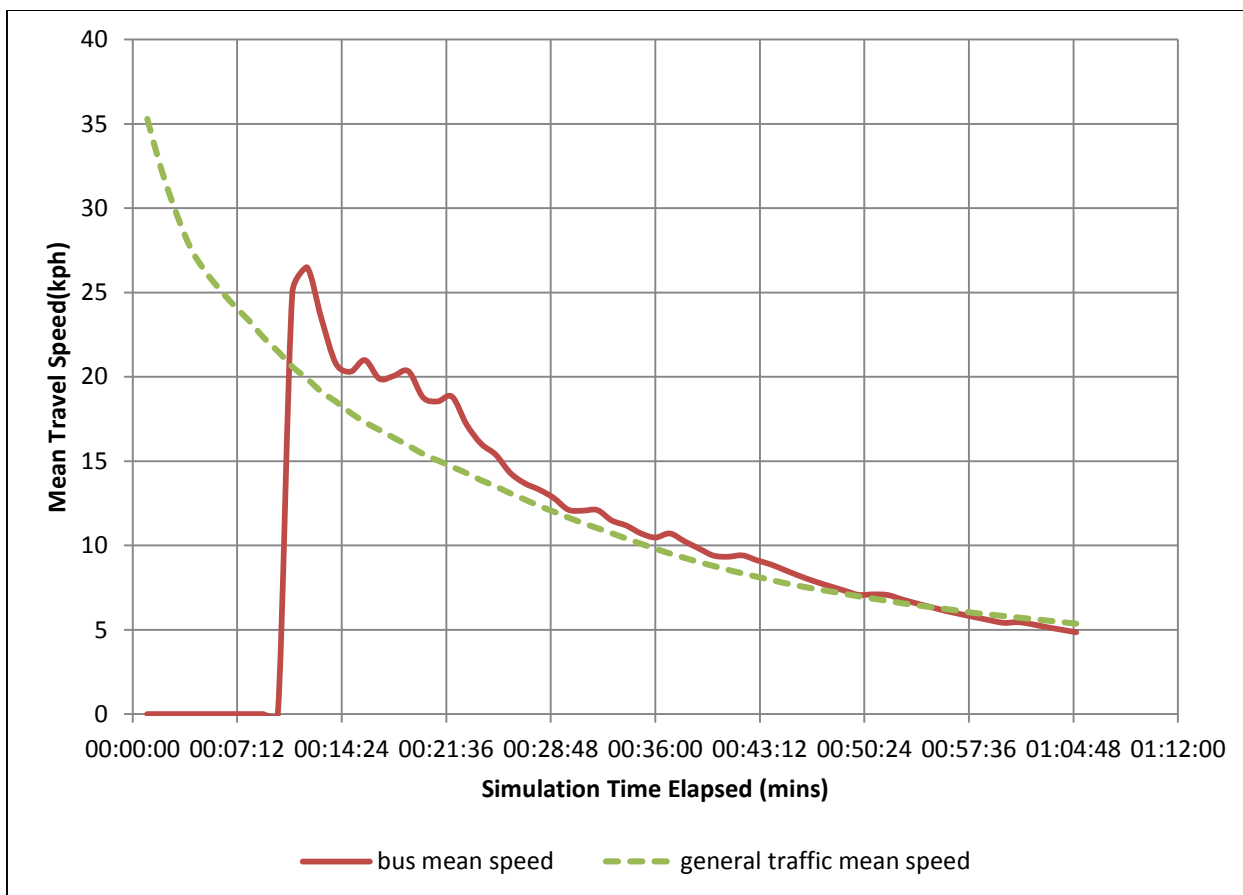

Figure 5-3 Bus Queue Jumper Lanes (BQJ) Scenario plot of Bus Vs General Traffic Speed

The averaged results show that bus and general speed is equivalent in this scenario. However, the bus mean speed is 10% faster at 20 km/hr during the first 15 mins of the peak hour but it unlike the preceding scenarios, its PT speed had exponential decay similar to general traffic. This finding shows that in addition to the travel delays along corridor segments, a large portion of arterial traffic delay and low bus speed can also be alluded to intersection poor performance and capacity. This is because the result shows that BQJ lanes are effective in reducing bus delay and increasing mean speed but this positive effect is diminished at higher levels of cross street volumes and congestion. However based on these indicative results, they remain a viable alternative especially at alleviating delay that occurs at intersection.

5.6 Bus Median with BSP Scenario

The following Figure 5-4 shows the Dedicated Bus lane with Median placement and BSP: the results indicate that the buses attained the highest operational speed for under this scenario i.e. 25 km/hr though this was for a short interval but throughout the simulation period it maintain at least +6 km/hr above mean general traffic speed, even though it has to make one to two stops per kilometre along the corridor i.e. average observed bus stop spacing was approximately 714 meters (14 stops on the 10 km segment modelled).

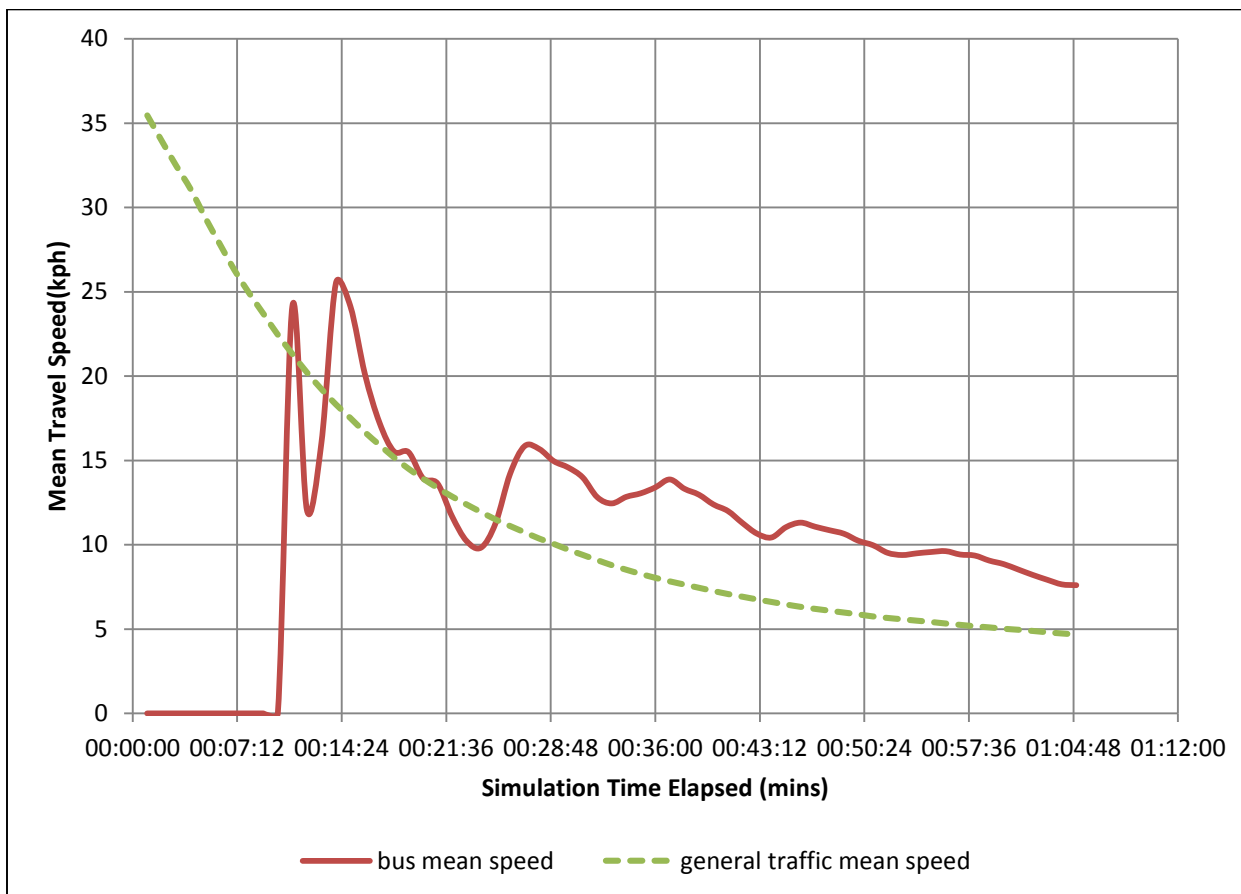

Figure 5-4 Bus Median with BSP Scenario plot of Bus Vs General Traffic Speed

The highest operational speed attained in the scenario compares well to performance seen on model systems like the Bogota's TransMilenio BRT (commercial operating speed of 28km/hr). The simulation indicates despite the increasing corridor congestion during the peak hour, that the buses speed in this scenario remain relatively constant at an average of 14 km/hr while the general traffic mean speed continues to reduce in the last half of the hour. This means that this scenario strongly favours the

movement of buses but will adversely affect the movement of general traffic as its speed is only slightly lower than the baseline, i.e. despite the restriction of a lane in each direction to general traffic.

5.7 Bus Median without BSP

Figure 5-5 shows that the removal of BSP further improves the performance of bus although the effect on general traffic is negligible. The type of BSP implemented was a *green call extension* and the results indicate this type of signal priority, when used in combination with median lanes may not be as effective as using strictly enforced BRT lanes on their own. The drastic improvement is evident especially in the most congested portion of the peak hour, while able to maintain speeds ranging from 15 km/hr to 18 km/hr.

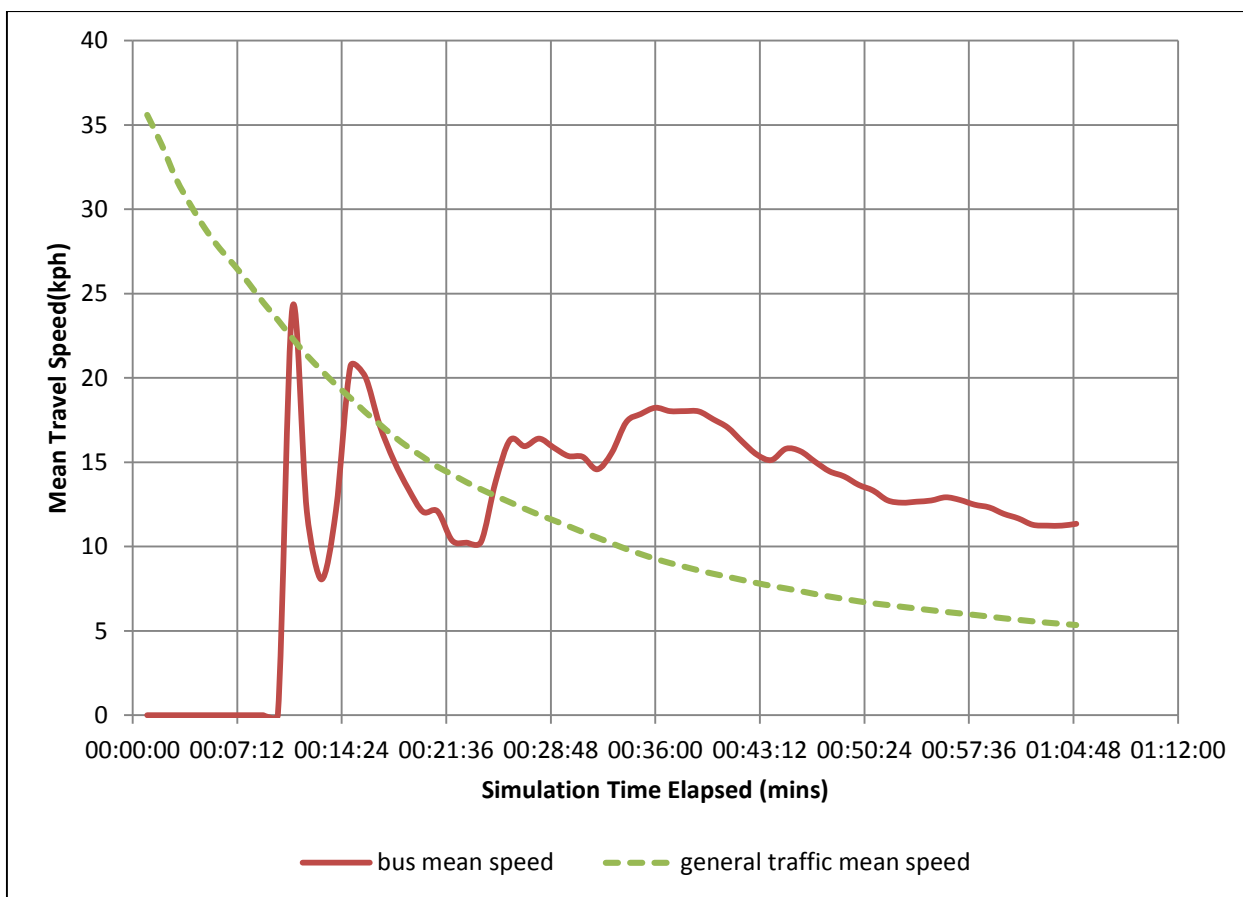

Figure 5-5 Bus Median without BSP Scenario plot of Bus Vs General Traffic Speed

It can be seen that though this scenario was not able to achieve the highest speeds of the BRT with BSP, it is able to maintain acceptable speeds of +15 km/hr even during the middle part of the peak hour i.e. even under the most congested corridor conditions, speed was above 12 km/hr.

5.8 Bus Kerbside without BSP

Figure 5-6 illustrates the negative effect on general traffic of dedicating a traffic lane to buses i.e. kerbside DBL (assumed 100% compliance to restriction). The bus speeds continue to show marked improvements consistent with other PT priority scenarios. However, there is a notable decrease in bus mean speed especially in the last 20 mins of simulation. This speed reduction was caused by turning movements and weaving movement into traffic stream under congested conditions in the model. This finding was consistent with observations as in along the Klipfontein corridor.

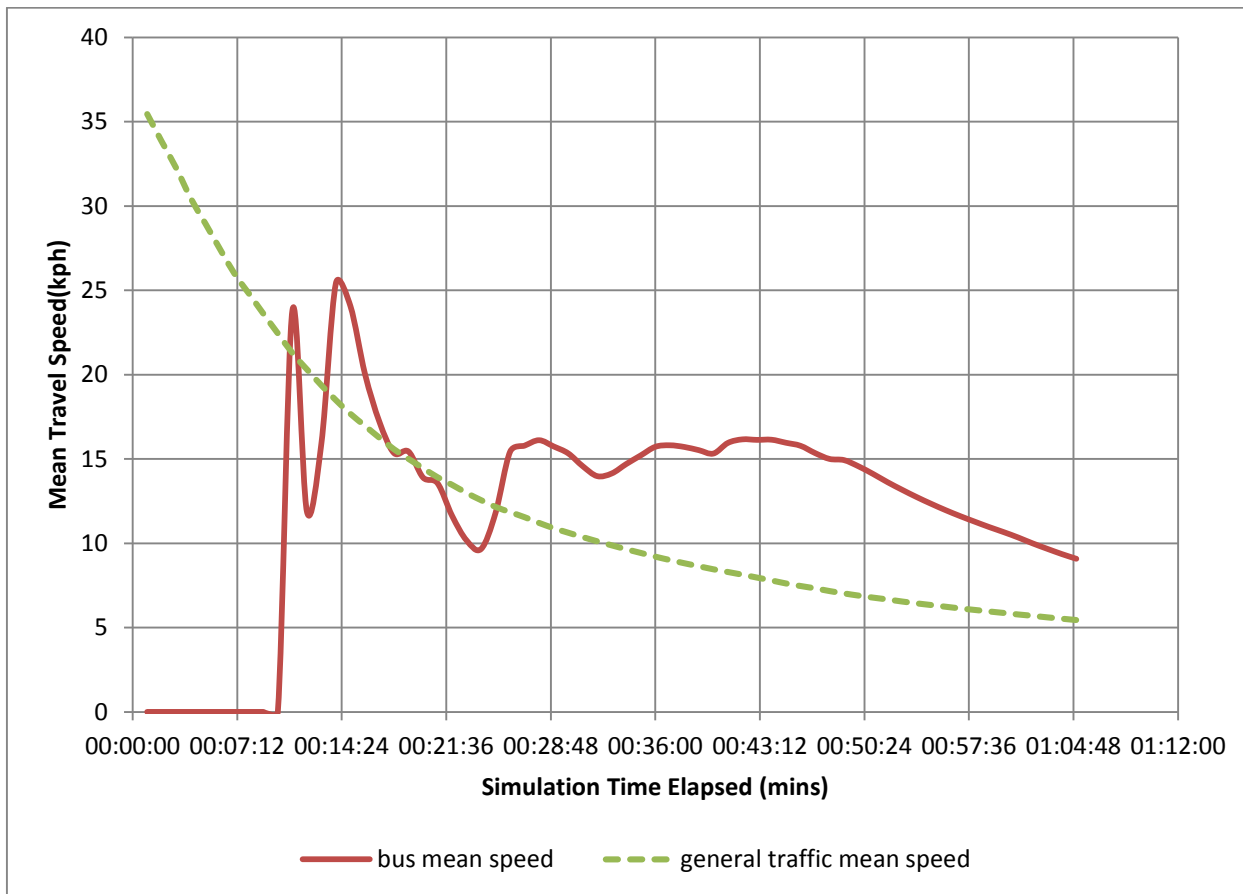

Figure 5-6 Bus kerbside without BSP Scenario plot of Bus Vs General Traffic Speed

Currently, there is a kerbside bus lane but it is not respected by general traffic due to poor enforcement, and hence, subject to disruption and effects of congestion. However, in this scenario this limited the congestion effect (mean speed reduction) to the latter part of the peak hour and to intersections i.e. where buses have to interact with general traffic.

5.9 Bus Kerbside with BSP

Figure 5-7 shows the outputs for this scenario and indicates that the combination of a kerbside BRT lane and BSP would improve the mean bus speed especially during the first 30 mins of the peak hour only. The introduction of BSP along the corridors would be an important option to better accommodate the key intersections like Vanguard and Klipfontein Road i.e. Vanguard is a major arterial and cross street, in this case, with relatively high peak hour volumes.

Despite, the relatively mean bus speeds in the first 20 min of the peak hour, it deteriorates rapidly during the critical portion of the peak hour (last 30 minutes) which is when the highest levels of congestion and traffic jams were observed on most segments of the corridor. It is clear that the call extensions (BSP measure used in this scenario) of up to 10 secs for buses are not very effective in alleviating the effect of congestion at intersections on both general traffic and buses. Actually, the results suggest that BSP, combined with kerbside BRT placement, could worsen LOS for buses under peak conditions.

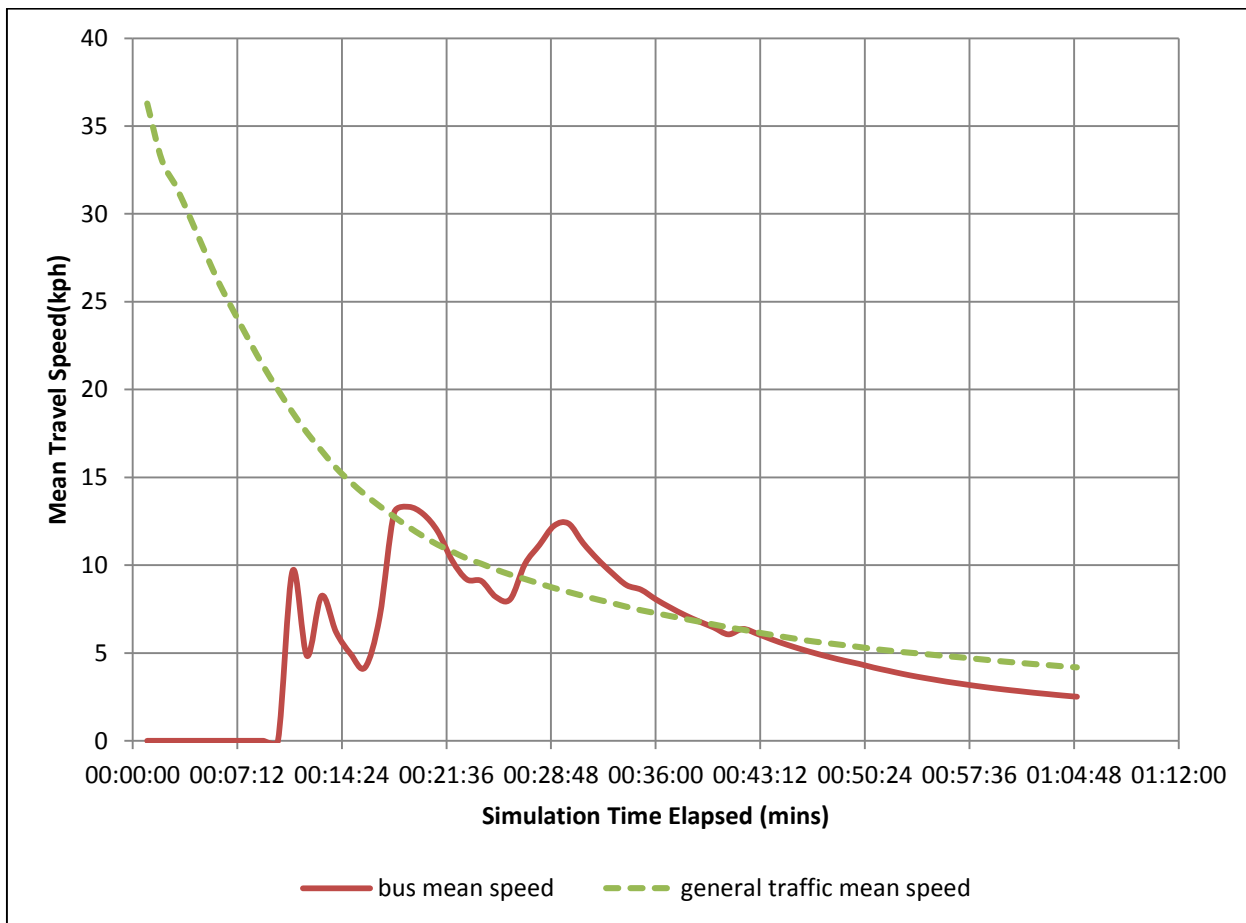

Figure 5-7 Bus kerbside with BSP Scenario plot of Bus Vs General Traffic Speed

The results predict that the combination of frequent call extensions by public buses and intersections with major cross street volumes would diminish the benefits of a kerbside lane. Therefore, when evaluating kerbside placement of BRT lanes, BSP is not a necessity. In either of the kerbside scenarios the effect of major cross street and turning movement has the most significant impacts which were able to improve

by optimisation of ordinary traffic signal timings (to accommodate these movements), which contributed to the comparably better results of the Kerbside without BSP.

5.10 Results Summary

Figure 5-9 shows a comparative plot of the averaged mean bus speed profiles for each scenario. There is a notable difference between the speed of the buses' and general traffic profiles (shown in Figure 5-8) the "ripples" i.e. in the bus profiles.

The "ripple" pattern seen in all the bus speed profiles can be explained by the station *clearance* and *weaving* manoeuvres i.e. which include slowing down to enter a station and gradually increasing speed while seeking an acceptable gap to re-enter general traffic flow. These results are consistent with observations that, despite the existence of bus lanes of the arterial, there is little compliance to or enforcement of them. Hence, they operate as general traffic lanes during peak hours particularly, which makes it difficult for buses to manoeuvre thus adding to delays and lower mean speeds.

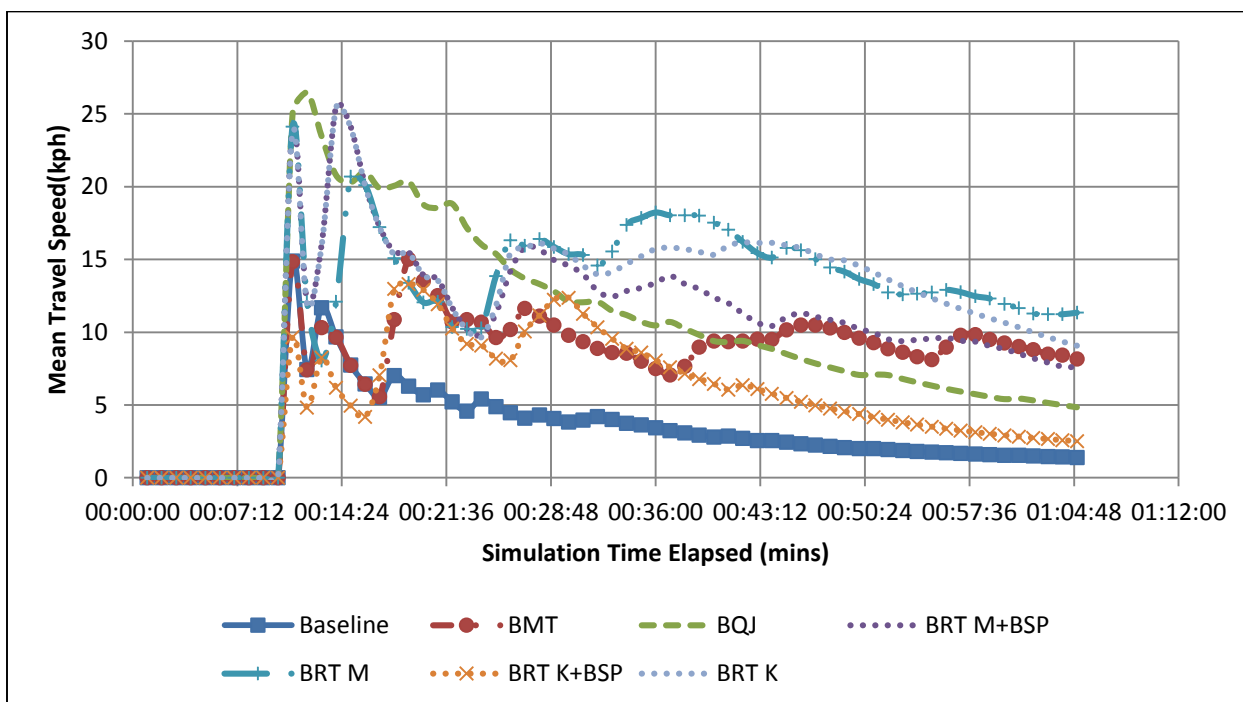

Figure 5-8 All Scenarios Bus Mean Speed Comparative Plot

The above results show that all scenarios offer a substantial improvement over current operating conditions as illustrated by the baseline scenario. The travel time data obtained from GABS, Cape Town's main public bus contractor indicates that it works with ideal speed of 10 km/hr, however the operation team indicated that during peak period this is often not achievable. Therefore, they often have to run extra buses on corridors like Klipfontein to reduce wait times for passenger at bus stops, this obviously adds to the cost of operations.

As expected, BRT Median and Kerbside scenarios are the best bus performance options, but this needs to be weighed within the context of additional expenses of specialised infrastructure which they require i.e. as explained in Section 2. The maximum mean bus speeds achieved in the aforementioned scenarios and respective sub-scenarios (with BSP) are consistent with those recommended in the BRT Standard Ratings i.e. +14 km/hr (Refer to Section 2). Therefore based on this, the BMT Lanes offer the more balanced improvement and the least negative impact of vehicle speeds (see Figure 4-9), BQJ is also an option that municipal transport authorities can explore, especially in segments or corridors that have limited road reserve and where rapid deployment is necessary i.e. BRT Standard Speed Vs GABS planning speed. It remains to be said that the status quo is unacceptable as it increases operator expenses which, in turn increases the need for subsidy of such public bus services and it increases delays for passengers due to lower speeds and poor intersection operations.

Conversely, Figure 5-9 shows that the average general traffic mean speed profiles have little variation between scenarios. However, the BRT Kerbside and Median with BSP have the most adverse impact on the general traffic mean speed i.e. at least 2 km/hr than other scenarios in the last 30 mins of the simulated peak hour.

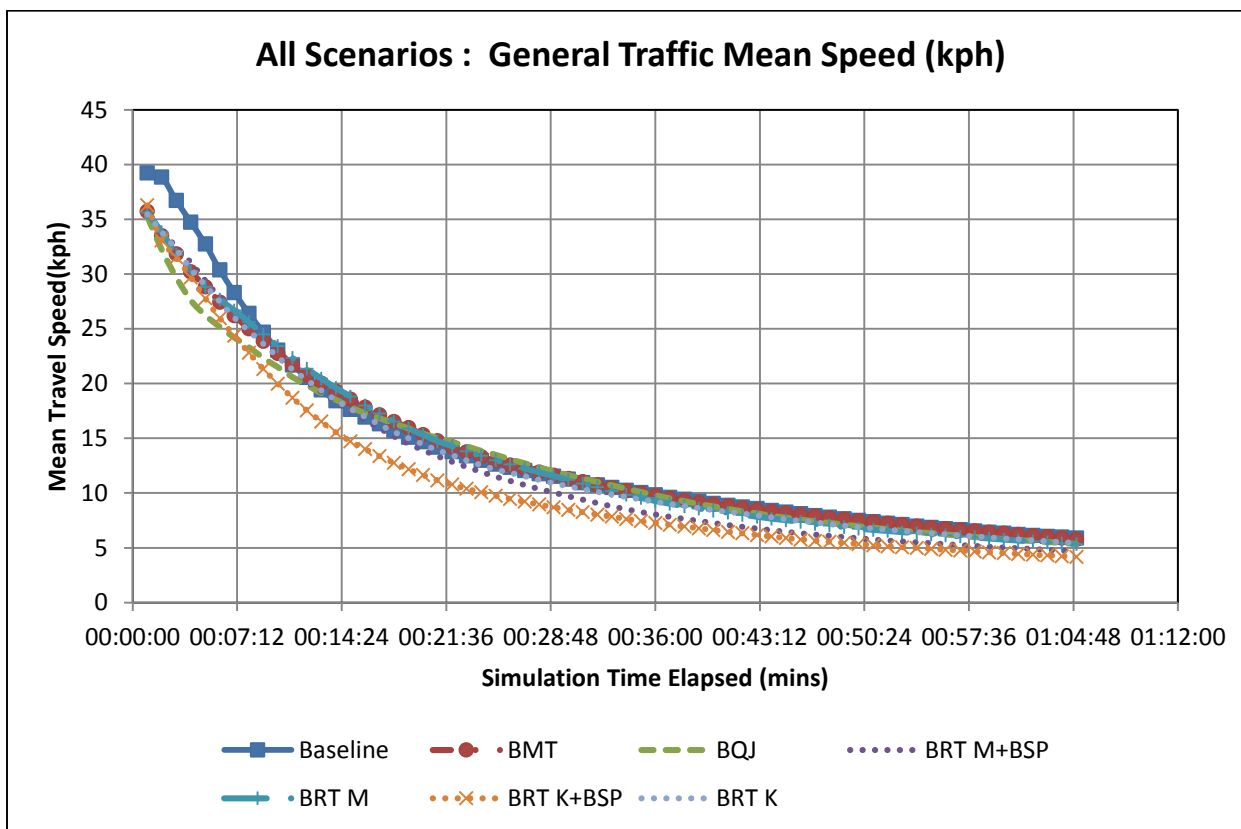

Figure 5-9 All Scenarios General Traffic Mean Speed Comparative Plot

The results also show that the BMT lane would have the least negative impact on the general traffic speed, though by a small margin. This can be attributed by the removal of Mini-Bus Taxis from general traffic; MBTs can constitute up to 40% of the modal share on major urban arterials like Klipfontein Road.

5.11 Delay Analysis

Table 5-2 shows that apart from the DBL K+BSP and DBL M+BSP scenarios, all other scenarios would result in reductions in bus travel time delay along the Klipfontein corridor modelled. The travel time delay reductions for buses range from -27% to -32% relative to the baseline scenario.

Table 5-2 All Scenarios General Traffic Mean Delay Comparative Plot

Modelled Scenario	Bus /PT Mean Delay(sec)	General Traffic Mean Delay(sec)	Net Change (Vs Base)	
			Bus (%)	Vehicles (%)
Baseline 2012	1295	1295		
Bus Mini-Bus Taxi Lane(Kerbside)	890	1266	-31%	-2%
Bus Queue Jumps	940	1282	-27%	-1%
DBL Kerbside	904	1252	-30%	-3%
DBL K+BSP	2100	2637	62%	104%
DBL Median	875	1375	-32%	6%
DBL M+BSP	1800	2591	39%	100%

Similarly, the vehicles also experienced marginal reductions in travel delays in some scenarios with the exception of the DBLK+BSP, DBL M and DBL M+BSP. The reductions in vehicle delays predicted range from -1% to -3% .This most likely indicates that general traffic travel times in these scenarios would not be affected from the status quo ,despite substantial improvements in public bus travel times.

The travel time delay results were subjected to a validation with actual travel time delays along the corridor. On the 24 and 25th July 2013, the author travelled along the corridor in a private during the peak period from 7h00 and 8h00 and recorded travel times . Based on a conservative estimate of free-flow speed of 40 km/hr the delay was calculated to be 1320 secs. This represents a 2 % deviation from the model predicted delay of 1295 secs (Table 5-2). A t-test at a 0.05 level of significance indicates that the aforementioned delays are not significantly different. Therefore, it can be concluded that the baseline model scenario was an accurate predictor of traffic movement, particularly with regard to travel time delays which are, in them, a function of mean speed and delays.

Table 5-3 Observed Vs. Modelled Travel Delay

Corridor Travel Times (secs)	Difference%
Modelled	-
Actual/Observed	2%

5.12 Statistical Analysis of Results: ANOVA

In Table 5-4 outputs from t-Test were used to test the averaged results obtained from the microsimulation results for statistical significance. All the analyses of variance were calculated relative to the Baseline 2012/13 scenario. The t-Test conducted assumed an equal variance between samples and at a 0.05 (α) level of significance. The null hypothesis tested was that each of the given scenarios improved the public bus speed by at least 3km/hr. This speed increase represents a 76% increase over current peak hour speeds i.e. 4 km/hr which is a third of the ideal speed of 12 km/hr of the GABS. This means such an improvement would bring the current speeds to within the range of the ideal operating speed used by Cape Town's bus main operator.

Table 5-4: Summary of t-Test results

t-Test: Two-Sample Assuming Unequal Variances			
Scenario	Mean Speed	P-value	t-Statistic
Baseline	3.90		
BMT	9.6	6.8E-09	6.2
BQJ	11.78	1.4E-07	5.6
BRT M+BSP	12.56	2.1E-14	8.9
BRT M	14.51	1.7E-26	14.1
BRT K+BSP	6.79	4.3E-01	0.2
BRT K	14.47	6.0E-24	13.1

Table 5-4 indicate that all the results from each modelled scenario were statistically significant. However, the results of the BRT K+BSP are the only inconclusive result based on the outcomes of this t-test calculation and level of significance. As shown in Table 5-3, its t-value is 0.2 and has a calculated P-value of 0.43. The null hypothesis was, therefore, rejected based on this evidence. Furthermore, results strongly support the research hypothesis that despite the major differences in the cost of deployment of priority measures, each could effectively increase peak hour bus performance in terms of speed. This means travel delays on public buses by 50% given that literature indicates that up to 80 % of travel delays arise from low operating bus speeds.

6 Conclusions: Consolidation of Findings

Based on the literature studied and the results of the microsimulation modelling; there is a consensus throughout literature that action needs to be taken to mitigate the effects of traffic congestion and delay on public transport modes. This implies that South Africa's public transport policy implementation needs to be executed in the most cost-effective manner to ensure that it attains the aforementioned objective.

Road space allocation and utilisation currently is not proportional to the mobility efficiency offered by the different modes that are used especially during critical times like peak travel hours. As has been shown in earlier chapters; Public Transport Priority Schemes can be used with varying success to correct this imbalance. However the following gaps and trends emerge in literature:

1. **Exact impact of partial vs strong priority schemes:** There is no literature or information in the public domain that clearly indicates the extent to which different bus priority schemes are effective in reducing travel delays, improving travel speeds and enhancing overall performance i.e. schedule adherence especially during peak travel times in South Africa. The North American experience with TSP and stronger measures like DBLs is well documented and quantified and has provided a number of sources of reference for this review, while the Latin America's model BRT experience has enjoyed greater prominence in generic guidelines for establishing BRT or enhanced bus services, such as the BRT Planning Guide (2007).
2. **Cost Effectiveness of Priority Schemes:** The cost implication of different priority measures is rarely stated in most studies. According to Currie and Sarvi (2013) this pattern is common throughout literature on the subject as most research focusses on the travel time impacts and road space allocations while omitting wider environment, operational and infrastructural impacts of which initial and life cycle costs are important factors.
3. **Exclusion of Network Effect:** All international and one local paper(s) that were reviewed describing similar studies of arterials such as Klipfontein Road have tended to focus on a single link with limited or no account of effect such as diversion traffic due to implementation transit priority. This represents a key strength of this study as the study area is modelled as a network, hence, this realistic behaviour can be accounted for in the simulation model.

The results detailed in Section 5 affirm the key hypothesis (see Abstract) and also provide insight into the other research questions that were sought to be answered by this investigation such as the extent of the benefits that can be expected from alternative forms of bus priority. Based on these results and findings the following conclusions are drawn:

6.1 What is the current extent of traffic congestion on South African urban corridors? .i.e. assess the performance public transport modes in the current (2012/13) traffic condition especially during daily travel peak periods?

The microsimulation results of this study confirmed that major urban arterials like Klipfontein are operating at over capacity and are highly congested. However, public transport is the worst affected by these adverse traffic conditions, as shown in Section 5.3.

The baseline scenario 2012/13 shows that the average operating speed is 5 km/hr or less for buses and private vehicles are relatively better at 7 km/hr during the am peak hour period. The private vehicle mean speed forms an upper boundary for which public buses do not exceed. With buses operating at $\approx 70\%$ of already low private vehicle mean speed, they are slow and this adds to the negative perception of public transport. The low operating speeds and high traffic volumes from major cross streets like Vanguard Road, often cause traffic conditions especially within the vicinity of the intersections. This highlights the urgent need for mitigation measures to improve public bus operations, in particular.

6.2 How does bus transit performance under partial priority compare to implementation of full priority as is the case in full BRT Systems?

This investigation has succeeded in beginning to quantify the extent of improvements that can be expected when alternative or partial priority measures are implement along a typical South African arterial. Furthermore, these were able to be compared to the predicted performance of a full specification BRT operation along the same corridor.

The benefits and performance improvements achievable by full specification BRT are well documented throughout literature and cannot be over-emphasised. However, the information (Section 4) shows that these systems are capital and infrastructure intensive. Conversely, partial priority measures, as described in Section 5 and 6 , require less infrastructure and road space ; to improve bus operation speed and delay indicators. The results in Section 8.2 support this assertion, for example in the BMT and BQJ scenarios the speeds of bus were increased by 4 and 7 km/hr respectively which represents an increase of more than 110% relative to a baseline of 4.0 km/hr under congested peak conditions (refer to Section 4).

As expected, the scenarios simulating full BRT operations i.e. BRT Kerbside and Median placement produced the best results with mean speed increases by at least 10 km/hr over the entire peak and even reaching 25 km/hr during early portions of the peak hour. The statistical analysis of the results indicates that at a 0.05 level of significance all full and partial bus measures, increased operating bus speeds by at least 70% or 3 km/hr. The latter and more conservative finding is key because it shows that partial priority measures like BQJs at key intersections are capable of producing considerable improvements to bus performance especially after further refinement for real world conditions. The LOS improvements offered by partial or alternative priority measures cannot be ignored and present a cost-effective and robust bus priority solution, especially for smaller municipalities and along key urban arterials.

Given that many municipal transport authorities are faced with fiscal limitation, it is essential that the deployments of these alternative forms of public transport priority are explored and implemented. As

stated , in Section 5.1 above, the level of improvement in operation parameters of the buses must be determined relative to specific conditions of corridors .For example , while in a certain transit corridor a +50% increase in bus speeds may be a requirement, in some less congested district a 20 % would present a drastic improvement. In essence, authorities must focus on the required outcomes and determine the appropriate method of achieving operational improvement needed rather than following prescriptive models of public transport improvement measures.

The extent of the speed improvements and delay reductions, shown in the results of this study, compare well with findings around the world and from literature sources. Based on the Hidalgo's (2010) comparison of BRT systems around the world, the peak hour speeds predicted by the model most closely resemble Indonesia's TransJakarta (operational speed 15 km/hr) and Seoul's and Sao Paulo's BRT with operating speeds of 17km /hr and 16km/hr. respectively (Hook,2008). However, this represents the lower quartile of ideal BRT systems ,such as Transmilenio ,that has recorded operational speeds of 21 -28 km/hr.

6.2.1 To what extent can bus priority measures improve the bus delay?

It is noted that given the high levels of congestions on the corridor of interest and poor status quo, the bus delay reductions were considerable compared to some international studies (Lahon, 2011) that report delay reductions of upto 10% for measures combining TSP and Bus Jumper Lane. While the Transit Capacity And Quality Of Service Manual (TCQSM)(2003) indicates that 5 – 27% reduction in travel delays with BSP measures, this study found the bus delay reductions to be 27 - 39% for the modelled scenarios (refer to Section 9).

The results must be viewed conservatively given the lack of adequate data to conduct a full scale validation and calibration exercise on the model. However, the model results of this academic study provide a good indication of the extent of the benefits and improvement that can be expected from each priority measure under South Africa conditions and are consistent with results of similar investigations.

6.3 What are the impacts of corridor based priority measures on other modes?

The main challenge of providing priority to public buses was the reduction of road capacity for the private mode. Conversely the results indicate private car also experienced marginal reductions in travel delays in some scenarios with the exception of the DBLK+BSP, DBL M and DBL M+BSP. The reductions in vehicle delays predicted range from -1% to -3%. With the BQJ scenario and DBL (without BSP) being the best interventions at 2% and 3% reduction respectively. This most likely indicates that these partial priority measures have a negligible impact on general traffic travel times. However, the BRT Kerbside and Median with BSP have the most adverse impact on the general traffic mean speed despite substantial improvements in public bus travel times i.e. at least 6% to 104% increases in delays relative to the baseline scenarios .

6.4 What is the most effective combination of bus priority measures?

Based on the results; BMT and BQJ are the most well-adjusted or optimal scenarios. They cause the least disruption to current traffic operations while substantially improving bus speeds. These scenarios showed decreases in bus delay by 27% and 31% respectively and both improved speeds by at least 50% during peak 15min of the peak hour. However, their impact on general traffic speeds is negligible as explained in earlier sections.

One of the common criticisms of traffic microsimulation models is that they are “data hungry” and often this is used as a justification for not using them as part of the transport planning process (Vanderschuren, 2006). However, when limited data is complemented with local knowledge it can provide a basis to develop a quantitative approach to gaining insight into the expected performance of such public transport systems operating in urban arterials.

For example, this study highlighted that BRT kerbside with BSP would not perform well because of the conflicts with turning movements and high volumes on major cross streets like Vanguard Road. Therefore, it is useful in avoiding costly system design flaws before deployment, such issues would be identified and rectified in the planning phases.

It is hoped that the finding of this study will help decision-makers determine the schemes that would provide maximum benefit to cost; along South African urban arterials. Hence, it can inform a framework for policymakers to evaluate different priorities objectively and with relevance to the required outcomes of a given bus service, rather than simply replicating model systems.

Lastly, the author seeks to make a contribution to the relatively small and emerging body of knowledge on priority strategy modelling in South Africa, thereby adding to the wider academic discourse and debate on the subject matter.

6.5 Recommendations

The mitigation of the impact of congestion on public transport modes, particularly public buses, is crucial to ensuring their effective operation. Literature has shown that buses remain an efficient and robust transport solution to today's increasing mobility demand, especially in urban areas. The need for innovative ways to increase capacity of the transport system is urgent, since conventional methods such as infrastructure expansion, are costly and difficult to implement i.e. at time of publication.

Based on the results of this investigation, the feasibility and effectiveness of partial bus priority measures in a South Africa context has been demonstrated. However, it is crucial that local authorities apply stricter enforcement for existing bus prioritisation, when bus lanes were modelled with 100% compliance (as would be the case in a BRT or strictly enforced bus lane) the drastic improvement in bus speeds were observed. This means that alternative priority schemes should be supported by travel demand management mechanisms such as parking restriction along transit corridors i.e. so that even more positive benefits can be extracted. The importance of this recommendation is that travel demand management mechanisms help reduce network congestion and instigate modal shifts to more efficient modes.

The author recommends the establishment of a Transport Mode Choice Framework (TMCF) for municipalities and local transport authorities. The results for this can be used as a benchmark for comparing outputs from their modelling exercises. Since, this research is based on typical South African conditions. This toolkit or framework would help local transport authorities to select a suitable public transport mode and features for a given urban context. In addition to helping select the most appropriate mode specification; it is envisioned that such a TMCF would include a set of guidelines to systematically determine the most viable and beneficial bus priority measure or combination of measures for a particular corridor or network.

The South African urban landscape is varied and influenced by a number of historical and socio-economic factors. Among other things most urban districts are characterised by the separation of land uses e.g. commercial, residential etc. and settlement patterns based on income-level. This means that often the ability of local authorities to provide quality mobility options like full specification BRT is often hampered by the lack of sufficient economic activity and settlement density required to justify such investments.

In view of the above, it remains necessary that high quality public transport systems are scaled and some components that are most appropriate are implemented to improve public transport operation in quicker time-frames and low costs in the interim. The transformation of South African urban corridors like Klipfontein Road into dense TOD areas is likely to be a phased gradual process. However, the poor LOS encountered by public transport modes along these corridors require immediate remediation to bring them to acceptable levels.

Goal-oriented planning and implementation must drive the improvement of public bus services. This means performance targets that are sensitive to a particular location should be for each major urban area. Therefore, context rather technology must form the basis of any public bus priority intervention. This means a process of "South Africanisation" needs to be carried out a particular bus operations model before it is adopted. By systematically interrogating new and emerging bus priority measures authorities will be

better able to make objective decisions regarding the most appropriate, sustainable and effective method of bus service enhancement. South African is in an advantageous position to learn from the early adopters of bus improvement models like Curitiba who rolled BRT like systems in 1972 and has inspired the much applauded TransMilenio in Bogota. The key is not simply replication of such systems into South African cities; but rather to understand which components of the respective systems have worked best and how assimilated in local contexts .i.e. fitness for purpose.

The results from this investigation show that tools like traffic micro simulation can help highlight issues or flaws in proposed transport infrastructure schemes and solve them before it is built. Microsimulation and modelling in general, allows decision-makers to validate and better understand the impacts of proposed transport skills. Rather than relying on prescriptive transport schemes without fully appreciation variation in context of their implementation. This is essential to promoting proactive approaches to traffic operations especially those affecting public buses. The development of human resources and institutional capacity in skills like transport modelling and planning is critical to designing, building and operating effective and functional public transport networks. This also calls for the engagement of the local academic community to create and adapt transport innovations for South African conditions and contexts..

In the course of this investigation, the strong interaction between the positive and negative financial cost implications and the LOS benefits of each bus priority measure became evident. Though this aspect was addressed to some degree (Section 3-17), it was outside the scope of this study. Therefore, for further research the author suggests a detailed analysis of the cost sensitivity and a full life cycle cost (LCA) of the specific priority measures in South African settings. It is important that decision-makers are selecting the most appropriate method of public transport prioritisation relative to their social and financial scale, rather than strictly following prescribed full specification BRT models.

7 Bibliography

- (British Department of Environment Transport Government and Regions). (2001). Keeping Buses Moving “A Guide To Traffic Management To Assist Buses In Urban Areas” (Second.). London: London Stationary Office.
- (City of Cape Town). (2011). Integrated Transport Plan 2006 - 2011. Transport Planning Branch , Cape Town. doi:10.1007/SpringerReference_16608
- (City of Cape Town). (2012). 2012 MyCiTi Business Plan, (September).
- (Department of Transport). Public Transport Strategy (2007).
- (Kittleson & Associates), (KFH Group), (Parsons Brincker Quade & Douglas), & Hunter-Zaworski, D. K. (2003). PART 4 BUS TRANSIT CAPACITY CONTENTS (pp. 4-1 – 4-110). Washington DC. doi:Report 100
- Akçelik, R. (2011). A Review of Gap-Acceptance Capacity Models (pp. 5–7).
- Albright, E., & Figliozzi, M. (2012). Factors Influencing Effectiveness of Transit Signal Priority and Late-Bus Recovery at Signalized-Intersection Level. *Transportation Research Record: Journal of the Transportation Research Board*, 2311, 186–194. doi:10.3141/2311-18
- Barker, J. B., Alvarez, D., & Barnes, R. L. (2003). *Bus Rapid Transit (Case Studies in Bus Rapid Transit) : APPENDIX A*.
- Barker, J. B., Alvarez, D., Barnes, R. L., Garber, C., Greene, S., Irwin, R. H., ... Rosenberg, J. M. (2003a). *Bus Rapid Transit Volume 2: Implementation Guidelines (Vol. 2)*. Transportation Research Board.
- Barker, J. B., Alvarez, D., Barnes, R. L., Garber, C., Greene, S., Irwin, R. H., ... Rosenberg, J. M. (2003b). *Bus Rapid Transit Volume 2: Implementation Guidelines (Vol. 2)*. Transportation Research Board.
- Behrens, R., & Jobanputra, R. (2012). The Impact Of Traffic Safety And Crime On Travel Behaviour And Attitudes In Cape Town : A Review Of Empirical Evidence.
- Clifton, G. T., & Rose, J. M. (2013). A simulation of the simple Mohring model to predict patronage and value of resources consumed for enhanced bus services. *Research in Transportation Economics*, 39(1), 259–269. doi:10.1016/j.retrec.2012.06.023
- CSIR. (2005). *Roads : Geometric design and layout planning Table Of Contents*. In CSIR Red Book.
- Daganzo, C. F. (2010). *Public Transportation Systems: Basic Principles of System Design, Operations Planning and Real-Time Control*. Berkeley, Carlifonia: University of Carlifonia,Berkeley.

- David Catling (Interfleet Technology Limited, U., Nils Jänig (TTK Karlsruhe, D., Johan van Ieperen (TTK Karlsruhe, D) Marc Perez, (TTK Karlsruhe, D) Per Andersson (Trivector, S., Daniel Svanfeldt (Trivector, S., & Martin Higginson (Corus, UK) Gradimir Stefanovic (GS, U. (2005). HiTrans Best Practice Guide : Public transport – Mode options and technical solutions.
- Dhruva Lahon. (2011). Modeling Transit Signal Priority and Queue Jumpers for BRT. *Intelligent Transport Engineering*, (December), 21 – 24.
- Diaz, R. B., Hardy, M., Bunch, J., Wnuk, L., Sam ZimmermanSilver, F., Chang, M., ... Schneck, D. (2004a). Characteristics of Bus Rapid Transit for Decision-Making, (August).
- Diaz, R. B., Hardy, M., Bunch, J., Wnuk, L., Sam ZimmermanSilver, F., Chang, M., ... Schneck, D. (2004b). Characteristics of Bus Rapid Transit for Decision-Making, (August).
- Dion, F., Rakha, H., Asce, M., & Zhang, Y. (2004). Evaluation of Potential Transit Signal Priority Benefits along a Fixed-Time Signalized Arterial, (June), 294–304.
- Eichler, M., & Daganzo, C. F. (2006). Bus lanes with intermittent priority: Strategy formulae and an evaluation. *Transportation Research Part B: Methodological*, 40(9), 731–744. doi:10.1016/j.trb.2005.10.001
- Gauthier, A., & Weinstock, A. (2010). Africa Transforming Paratransit into BRT. *Built Environment*, 36(3), 317–327. doi:10.2148/benv.36.3.317
- GCIS-RSA. National Land Transport Act. , Pub. L. No. 5 (2009).
- Hensher, D. (2006). Productivity Measurement In The Urban Bus Sector. In *Bus Transport handbook* (pp. 221 – 258).
- Hensher, D. a., & Golob, T. F. (2008). Bus rapid transit systems: a comparative assessment. *Transportation*, 35(4), 501–518. doi:10.1007/s11116-008-9163-y
- Hidalgo, D., & Carrigan, A. (2010). *Modernizing Public Transportation*. Transport. Washington DC.
- Hook, W., Breithaupt, M., Wright, L., Hidalgo, D., Menckhoff, G., Martins, W. C., ... Rutherford, S. (2013). *THE BRT STANDARD 2013*. New York: Institute for Transport & Development Policy and Deutsche Gesellschaft für Internationale Zusammenarbeit (GIZ) GmbH Dag-Hammarskjöld-Weg.
- Hotel, R., & Rouge, B. (2003). *Proceedings of the Ninth TRB Conference on the Application of Transportation Planning Methods*.
- Hounsell, N. B., & Shrestha, E. P. (2004). *Bus Priority At Traffic Signals : Investigating The Options*, 287–294.
- Kerkhof, A., & Soulas, C. (2011a). *Buses with High Level of Service*. Office, 0603(October 2007).

- Kerkhof, A., & Soulas, C. (2011b). Buses with High Level of Service. Office, 0603(October 2007).
- Kim, S., Park, M., & Chon, K. S. (2012). Bus signal priority strategies for Multi-directional bus routes. *KSCE Journal of Civil Engineering*, 16(5), 855–861. doi:10.1007/s12205-012-1504-7
- Kumar, A., & Barret, F. (2008). Stuck in Traffic: Urban Transport in Africa (Africa Infrastructure Country Diagnostic).
- Lee, D. A., Cook, G., Ford, N. P., Freeland, R. L., Gilliam, F. M., Hough, J. A., & Bridge, G. G. (2006). Synthesis 64: Bus Use of Shoulders. Washington DC. doi:ISDN : 0-309-09764-3
- Lee, D. A., Watson, C., Hair, V. I. C. E. C., Miller, D. L., Dot, K., Irector, E. X. D., ... Wilson, F. (2007). Bus Rapid Transit Practitioner's Guide. Washington DC. doi:Report 118
- Lindau, A. L., Hidalgo, D., & Facchini, D. (2010). Curitiba , the cradle of Bus Rapid Transit.
- Miller, M. A. (2009). Bus Lanes / Bus Rapid Transit Systems on Highways : Review of the Literature.
- Muñoz, J. C., & Hidalgo, D. (2012). A Review of Technological Improvements in BRT and BHLS (pp. 1–20).
- O'Flatory, C. . A., Nash, C., Bell, M. G., Bonsnall, P. W., Leake, G., & May, A. (1997). Transport Planning & Traffic Engineering (1st ed.). London: Arnold(Holder Headline Group).
- Patience, D., & (Traffic Management Centre). (2012). Discussion about the actual state of Road based ITS systems in Cape Town. Cape Town.
- Policy, N. M. T. (2005). City Of Cape Town : Nmt Policy And Strategy Volume 1 : Status Quo Assessment. Assessment.
- Salazar Ferro, P., Behrens, R., & Wilkinson, P. (2013). Hybrid urban transport systems in developing countries: Portents and prospects. *Research in Transportation Economics*, 39(1), 121–132. doi:10.1016/j.retrec.2012.06.004
- Skabardonis, A., & Christofa, E. (2011). Impact of Transit Signal Priority on Level of Service at Signalized Intersections. *Procedia - Social and Behavioral Sciences*, 16, 612–619. doi:10.1016/j.sbspro.2011.04.481
- Tom V. Mathew(IIT, B. (2012). Traffic Engineering and Management. Bombay.
- Treiber, M., Hennecke, a, & Helbing, D. (2000). Congested traffic states in empirical observations and microscopic simulations. *Physical review. E, Statistical physics, plasmas, fluids, and related interdisciplinary topics*, 62(2 Pt A), 1805–24.
- Vanderschuren, M. (2006). Intelligent Transport Systems For South Africa. University Of Cape Town.

- Vuchic, V. R. (2002). Bus Semirapid Transit Mode Development, 71–95.
- Vuchic, V. R. (2007). *Urban Transit Systems and Technology*. Hoboken, New Jersey: John Wiley & Sons Inc.
- Walters, J. (2013). Overview of public transport policy developments in South Africa. *Research in Transportation Economics*, 39(1), 34–45. doi:10.1016/j.retrec.2012.05.021
- Waterson, B. J., Rajbhandari, B., & Hounsell, N. B. (2003). Simulating the Impacts of Strong Bus Priority Measures, (December), 642–648.
- Wirasinghe, S. C., Kattan, L., Rahman, M. M., & Hubbell, J. (2013a). *International Journal of Urban Sciences BRT – a review*, (September 2013), 37–41. doi:10.1080/12265934.2013.777514
- Wirasinghe, S. C., Kattan, L., Rahman, M. M., & Hubbell, J. (2013b). *International Journal of Urban Sciences BRT – a review*, (September 2013), 37–41. doi:10.1080/12265934.2013.777514
- Wood, A. (2014). *The Politics of Policy Circulation: unpacking South African and South American Cities in Adoption of BRT*. Antipode, (December).
- Wright, L. (ITDP), & Fjellstrom, K. (GTZ). (2003). *Mass Rapid Transit Guide Source Book*. (K. Fjellstrom(GTZ), Ed.). GTZ Transport and Mobility Group.
- Wright, L., & Hook, W. (2007). *Bus Rapid Transit Planning Guide*. (Lloyd Wright: Walter Hook, Ed.)(third.). Institute for Transport & Development Policy.
- Wu, J., Brackstone, M., & McDonald, M. (2003). The validation of a microscopic simulation model: a methodological case study. *Transportation Research Part C: Emerging Technologies*, 11(6), 463–479. doi:10.1016/j.trc.2003.05.001
- Wu, N. (2001). A universal procedure for capacity determination at unsignalized (priority-controlled) intersections. *Transportation Research Part B: Methodological*, 35(6), 593–623. doi:10.1016/S0191-2615(00)00012-6
- Xu, H., Ph, D., Sun, J., & Zheng, M. (2010). *Comparative Analysis of Unconditional and Conditional Priority for Use at Isolated Signalized Intersections*, (December).
- Zhu, H. B. (2010). Numerical study of urban traffic flow with dedicated bus lane and intermittent bus lane. *Physica A: Statistical Mechanics and its Applications*, 389(16), 3134–3139. doi:10.1016/j.physa.2010.03.040
- Zohdy, I. (2009). *Modeling Permissive Left-Turn Gap Acceptance Behavior At Signalized Intersections* Ismail Zohdy Modeling Permissive Left-Turn Gap Acceptance Behavior At Signalized Intersections. Master Thesis. Virginia Polytechnic Institute and State University.

8 Appendix

The OD Matrix as output from PARAMICS, it was the same input for all the modelled 6 scenarios:

Klipfontein-Lansdowne Simulation Model O-D Matrix																
Zones	2	3	8	9	16	5	6	7	10	15	4	14	12	13	1	Total Productions
2	0	242	145	500	500	500	242	242	242	242	242	242	300	500	100	4239
3	500	0	145	500	500	500	242	242	242	242	242	242	300	300	115	4312
8	1500	500	0	1000	500	500	242	242	242	242	242	242	300	300	45	6097
9	500	500	115	0	500	500	242	242	242	242	242	242	500	242	100	4409
16	500	300	45	300	0	500	500	500	500	500	242	242	242	100	100	4571
5	500	200	175	300	0	0	200	300	500	200	242	242	242	100	1200	4401
6	1509	300	200	300	15	500	0	500	500	500	500	500	500	100	45	5969
7	500	242	242	242	24	500	500	0	500	500	500	500	500	100	100	4950
10	500	242	242	242	36	500	500	500	0	500	500	500	500	100	75	4937
15	500	242	18	242	15	500	500	500	500	0	500	500	500	100	24	4641
4	363	90	151	242	60	333	151	303	242	60	0	151	454	100	100	2800
14	500	500	500	500	0	500	500	60	151	60	500	0	100	100	100	4071
12	300	200	242	142	0	100	42	42	12	12	100	0	0	100	75	1367
13	100	200	342	242	0	400	200	100	200	42	300	0	200	0	200	2526
1	145	100	45	45	100	45	45	66	45	24	200	45	145	245	0	1295
Totals Att	7917	3858	2607	4797	2250	5878	4106	3839	4118	3366	4552	3648	4783	2487	2379	60585