

THE PLATELET LAMININ RECEPTOR

**DISCOVERY OF A 67kDA RECEPTOR FOR LAMININ
ON THE MEMBRANES OF HUMAN PLATELETS:
CHARACTERISATION AND ISOLATION.**

13 P/s
P5

by
ERROL A HOLLAND
MBChB (UCT) FCP (SA)

A THESIS PRESENTED FOR THE DEGREE OF DOCTOR OF PHILOSOPHY
(MEDICINE)
UNIVERSITY OF CAPE TOWN
AUGUST, 1994

This thesis is the property of the University of Cape Town and is loaned to the reader on the understanding that it is not to be reproduced, stored in a retrieval system, or transmitted in any form or by any means, electronic, mechanical, photocopying, recording, or otherwise, without the prior written permission of the University of Cape Town. All rights reserved.

The copyright of this thesis vests in the author. No quotation from it or information derived from it is to be published without full acknowledgement of the source. The thesis is to be used for private study or non-commercial research purposes only.

Published by the University of Cape Town (UCT) in terms of the non-exclusive license granted to UCT by the author.

DEDICATION

TO MY PATIENT AND SUPPORTIVE FAMILY

I declare that this dissertation is my own, unaided work. It is being submitted for the degree of Doctor of Philosophy (Medicine) to the University of Cape Town. It has not been submitted before for any degree or examination to any other University. This thesis was compiled while I was employed by the Department of Haematology of the University of Cape Town

ERROL ANTHONY HOLLAND.

PROMOTORS: **PROFESSOR P. JACOBS**
 HEAD, DEPARTMENT OF HAEMATOLOGY
 UNIVERSITY OF CAPE TOWN

PROFESSOR G.A. JAMIESON
HEAD, CELL BIOLOGY DEPARTMENT
THE JEROME H. HOLLAND LABORATORY
AMERICAN RED CROSS

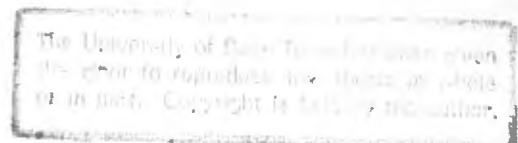

ACKNOWLEDGEMENTS

I wish to thank the following persons for their invaluable assistance, interest and encouragement without which this thesis would have been impossible to produce:

Professor Peter Jacobs - University of Cape Town

Professor Graham A Jamieson and the staff of the Cell Biology Laboratory of the Biomedical Research and Development Facility of the American Red Cross, Narendra N Tandon, Nicholas Greco and Andrea Hines, who also supplied most of the reagents for this study.

Professor Leon Hoyer of the Biomedical Research and Development Facility of the American Red Cross for the supply of the purified von Willebrand factor.

Dr. Margaret Johnson of Christiana hospital, Wilmington, Delaware for arranging for the blood samples from the patients with Glanzmann's Thrombasthenia

Professor Robert J Jacobson and Professor Ronald A Sacher of the Georgetown University Medical Center.

Dr. Asgar A Kalla - Groote Schuur hospital.

Mr. Sediek Isaacs of the statistics department of Groote Schuur Hospital.

TABLE OF CONTENTS

	PAGE
Acknowledgements	I
List of Abbreviations	II
List of Plates	V
List of Tables	VI
List of Graphs	VII
Abstract	VIII
Chapter I. Literature Review	1
Chapter II. Characterization of Platelet Adhesion to Laminin	18
A. Development of micro-titre assay for measuring platelet-laminin interaction	18
1. Laminin concentration	20
2. Platelet concentration	22
3. Duration of incubation of platelet suspension with laminin	24
4. Cation requirement	26
5. Specificity	29
6. Distribution of platelet adhesion in normal volunteers	32
B. Effects of platelet activation	35
1. ADP activation	35
2. Thrombin activation	38
C. Role of known platelet glycoproteins	43
Effects of platelet membrane proteolysis	43
1. Trypsin	43
2. Chymotrysin	46
3. Serratia marcescens	50

TABLE OF CONTENTS (continued)

	PAGE
Antibody studies	52
1. Anti-glycocalicin	52
2. Anti-glycoprotein IV	53
Clinical study - Glanzmann's Thrombasthenia	55
D. Role of adhesive proteins	58
1. Fibrinogen	58
2. von Willebrand factor	62
3. The adhesion peptide - RGDS	64
Chapter III. Isolation of the	
Platelet Laminin Receptor	69
A. Preparation of solubilized platelet membranes ...	69
B. Preparation of laminin-Sepharose column	70
C. Binding of solubilized platelet membranes to column	70
D. Electrophoresis of the eluate	71
E. Blot identification	74
Chapter IV. Additional Confirmation	76
A. Perfusion studies	76
B. Flow cytometry	77
C. Receptor elution from laminin-Sepharose column ..	78
D. Immunoinhibition with monoclonal antibodies	80
E. Peptide adhesion studies	82
F. Laminin fragment Sepharose column studies	84
Chapter V. Conclusions and Implications	85
The micro-titre assay	85
The physiology of the 67kDa receptor for laminin on platelet membranes	87
The role of platelets in metastasis	91
Chapter VI. References	104

LIST OF ABBREVIATIONS

ADP	adenosine 5'-diphosphate.
AMP	adenosine 5'-monophosphate.
BSA	bovine serum albumin.
Buffer A	5.0mM tris; 5.5mM glucose; 150mM NaCl; 2.0mM MgCl ₂
CD.....	cluster of differentiation
CPD	anti-coagulant used for blood collection: Trisodium-citrate.2H ₂ O (80.24mM); dextrose.H ₂ O (161.11mM); Citric Acid.H ₂ O (15.57mM); NaH ₂ HPO ₄ .H ₂ O (16.00mM); Adenine (2.037mM).
EGTA	ethyleneglycolbis-(aminoethylether) -tetraacetate.
EHS	Engelbreth-Holm-Swarm.
GP	glycoprotein.
PBS	phosphate buffered saline.
PRP	platelet-rich plasma.
RGDS	tetra-peptide: arginine-glycine-aspartic acid-serine.
SDS	sodium dodecyl sulphate.
VLA	very late antigen.
vWf	von Willebrand factor.
YIGSR	pentapeptide: tyrosine-isoleucine-glycine -serine-arginine.

LIST OF PLATES

	Page:
Plate 1. In-vitro laminin structure.	11
Plate 2. Model of laminin structure.	12
Plate 3. Model of chain arrangement.	14
Plate 4. Model of chain molecular arrangement.	15
Plate 5. Elution of membrane components from the laminin-affinity column.	72
Plate 6. Platelet membrane laminin receptor.	73
Plate 7. Laminin binding to isolated receptor.	75
Plate 8. Elution pattern from laminin-sepharose	79
Plate 9. Immunoinhibition of platelet adherence	81
Plate 10. Adhesion of platelets to laminin-derived peptides	83

LIST OF TABLES

	Page:
Table 1. Adhesion following platelet activation with ADP	37
Table 2. Adhesion of platelets treated with 0.2mg/ml of <i>Serratia marcescens</i> metalloprotease for varying periods of time	51
Table 3. Adhesion of platelets in the presence of varying concentrations of anti-glycocalicin Fab	53
Table 4. Adhesion of platelets in the presence of varying concentrations of anti-GPIV Fab	54
Table 5. Adhesion in the presence of varying concentrations of the RGDS peptide	66

LIST OF GRAPHS

	Page:
Fig.1. Laminin concentration	21
Fig.2. Platelet concentration	23
Fig.3. Incubation period	23
Fig.4. Cation requirement	28
Fig.5. Specificity of assay	31
Fig.6. Distribution of adhesion of the platelets of normal volunteers	33
Fig.7. Effect of thrombin activation	41
Fig.8. Adhesion following on treatment of platelets with trypsin 0.1mg/ml	45
Fig.9. Effect of treatment of platelets with chymotrypsin 0.1mg/ml	48
Fig.10. Effect of treatment of platelets with chymotrypsin 0.1mg/ml, chymotrypsin 0.2mg/ml and trypsin 0.1mg/ml	49
Fig.11. Clinical Study - Glanzmann's Thrombasthenia ...	56
Fig.12. Interaction with fibrinogen	60
Fig.13. Effect of von Willebrand Factor	64
Fig.14. Effect of pre-incubation of the laminin coated wells with fibrinogen and von Willebrand Factor	68

ABSTRACT

Previous work on the binding of resting platelets to the basement membrane glycoprotein, laminin, has identified the Ic/IIa integrin complex (CD49f/CD29), also known as VLA-6, as the receptor. There exists however, another protein with a molecular weight of 67kDa, that mediates this function on other cells. It is abundantly expressed on the membranes of breast cancer cells, where it plays a key role in both the localisation at, and penetration of vascular beds, by metastases.

The objectives of this study were:

- The development of a micro-titre assay similar to those used in previous studies, standardised and calibrated to characterize the adhesion of unstimulated normal human platelets to laminin-coated surfaces.
- To determine the effect on adhesion of platelet activation, enzymatic surface-glycoprotein removal, antibodies to specific receptors and interaction with other adhesive proteins known to bind to platelet membranes.
- To establish the in vivo relevance of the experimental findings, by the assay of adhesion of glycoprotein IIb/IIIa-deficient platelets of two patients with Glanzmann's Thrombasthenia.

These studies served to distinguish specific binding sites for laminin from the known surface receptors of platelets.

The methodology used to isolate laminin receptors from the membranes of breast carcinoma cells was then applied to platelet concentrates. Membranes were obtained by centrifuging the ultrasonic lysate of a unit of platelets. These were solubilized and passed over a laminin-Sepharose column. The bound components were eluted and identified by means of SDS-gel electrophoresis, after which a concentrate

was tested for laminin binding by means of dot-blot methodology.

The principle contribution of this work is the finding of a 67kDa receptor for laminin on the surface membranes of platelets.

The combination of the various approaches applied to characterise the adhesion of platelets to laminin, show that this is a specific, Mg^{2+} -dependent process, inhibited by Ca^{2+} and not enhanced by platelet activation. Adhesion was decreased by proteolysis with trypsin and chymotrypsin, showing that the adhesion is mediated by a surface glycoprotein. Proteolysis with the *Serratia marcescens* metalloprotease, which cleaves off glycoprotein Ib, did not affect adhesion, proving that this well known receptor for platelet adhesion is not involved in the adhesion. The receptors GPIV and glyocalicin were also excluded, as the presence of antibodies to these receptors had no effect. Prior incubation with fibrinogen or von Willebrand factor, which binds to specific receptors on the platelet membrane, inhibited adhesion, most likely due to spatial interference with the receptor site for laminin. The presence of the tetrapeptide recognised by the membrane receptors for many adhesive proteins, RGDS, at concentrations of up to 1mM, had no effect. The platelets of the two subjects with Glanzmann's Thrombasthenia adhered normally, definitively ruling out the involvement of GPIIb/IIIa, which is absent from these platelets.

The isolation process recovered a membrane component from the laminin-Sepharose column with an elution pattern identical to that for the well characterised 67kDa receptor for laminin on the surface of breast carcinoma cells. They have the same molecular weights in both the reduced (67kDa) and non-reduced (53kDa) states. Blot identification demonstrated laminin binding by the eluate.

In the last part of the work, collaborative studies using more sophisticated methodology have confirmed that platelet receptors for laminin play a role in their adhesion to living tissue. Anti-laminin Fab antibodies significantly decreased the adhesion when whole blood was perfused over isolated rabbit aortic segments. That these receptors are identical to the 67kDa receptor of breast carcinoma cells was shown by the specific, high affinity binding of antibodies directed at the carcinoma receptors to the surface of platelets when examined by flow cytometry. In addition, they inhibit platelet adhesion by 50-60% in the micro-titre assay.

It is proposed that both the VLA-6 and the 67kDa receptors are required for platelet adhesion to laminin, possibly as a two stage process, similar to the systems for adhesion to von Willebrand factor, where binding is initially to GPIb, followed by binding to GPIIb/IIIa. The possible relevance of this receptor in the pathophysiology of the metastatic process is discussed.

I. LITERATURE REVIEW

PLATELET INTEGRINS AS ADHESIVE RECEPTORS

Integrins are a family of transmembrane glycoprotein receptors, comprised of noncovalent alpha/beta heterodimer protein complexes. They derive their name from Hynes (1987), who described this superfamily of adhesion receptors which are structurally, immunologically and functionally related. Their prime function is to integrate cell signals between the cytoskeleton and the extracellular matrix. They participate in major biological processes in which cell to matrix and cell to cell adhesion is operative: embryological development; haemostasis and thrombosis; wound healing; immune and non-immune defense mechanisms; oncogenic transformation and invasion.

Each member of the superfamily has a unique alpha and one of three beta subunits, designated beta₁₋₃. Integrins with beta₁ and beta₂ subunits are important receptors of the platelet membrane:

A. THE VLA FAMILY

The members of this family share the beta₁ subunit. These receptors were first described on activated T lymphocytes after several weeks of in vitro stimulation with antigen, and thus termed very late antigens (VLA). With the use of VLA-specific monoclonal antibodies, the platelet membrane glycoproteins GPIIa, GPIa and GPIc were demonstrated to form heterodimers similar to the VLA receptors for matrix proteins on activated lymphocytes (Pischel et al, 1988). Each alpha subunit possesses a signal peptide followed by a long extracellular fragment with seven homologous repeating domains towards the amino terminus, a single transmembrane domain and a short cytoplasmic sequence (Takada and Hemler, 1989) Platelet receptors within this group include:

1. The Collagen Receptor - VLA-2 (CD49b/CD29)

The complex of Glycoprotein Ia (CD49b) and IIa (CD29) is involved in the adhesion of platelets to collagen (Santoro, 1986). With the use of an antibody to the receptor of fibroblasts for this protein, inhibition of platelets to type I and type III collagen was found (Kunicki et al, 1988). Structural homology to the fibroblast collagen receptor was also demonstrated by peptide mapping. The binding of purified GPIa-IIa to collagen is Mg^{2+} -dependent (Staatz et al, 1989). When platelets adhere to collagen through VLA-2, they undergo activation and granule secretion. Its physiologic role in haemostasis was confirmed by studies of a family with a selective deficiency of VLA-2 who presented with an inherited bleeding syndrome (Nieuwenhuis et al, 1985). Defective platelet-collagen interaction was demonstrated (Nieuwenhuis et al, 1986). However, other receptors and plasma factors appear to be involved in the adhesion of platelets to collagen as well (Coller et al, 1989): In the presence of plasma, antibodies to the GPIa/GPIIa complex, together with antibodies to the fibrinogen receptor GPIIb/IIIa, inhibited adhesion incompletely, but to a greater degree than either of the antibodies alone. A two-step, two-site model for collagen-induced cell signalling, adherence, activation and secretion has been proposed (Santoro et al 1991). It involves both VLA-2 and a signal-transducing receptor. GPIV (see below) may be involved in the signal transduction phase

2. The Fibronectin Receptor - VLA-5 (CD49e/CD29)

The complex of glycoprotein Ic (CD49e; MW 165,000) and IIa (CD29; MW 145,000) has been identified as the mediator of adhesion of unactivated platelets to fibronectin (Piotrowicz et al, 1988). The complex corresponds to VLA-5 (Pischel et al, 1988), which is identical to the fibroblast fibronectin receptor (Takada et al, 1987, Wayner et al, 1988). The latter authors have demonstrated that antibodies to this

receptor of fibroblasts, inhibited the adhesion of platelets to fibronectin-coated micro-titre plates and precipitated with glycoprotein Ia (alpha subunit) and glycoprotein IIa (beta subunit).

3. The Laminin Receptor - VLA-6 (CD49f/CD29)

A complex of GPIc (CD49f) and IIa (CD29) which have similar but unique structural properties to VLA-5, was identified on fibroblasts as the VLA-6 receptor (Hemler et al, 1988). VLA-6 complexes have been identified on platelet membranes which bind to Sepharose columns to which the E8 fragment of the laminin molecule is linked (Sonnenberg et al, 1991). Platelet adhesion to laminin-coated micro-titre plates was inhibited in the presence of monoclonal antibodies to VLA-6 (Sonnenberg et al, 1988). These studies are reviewed later.

B. THE CYTOADHESIN FAMILY

Members of this family share the beta₃ subunit and are found in abundance on the membranes of platelets, endothelial cells, smooth muscle cells, monocytoïd cells and fibroblasts (Ginsberg et al, 1988).

1. Glycoprotein IIb/IIIa (CD41a)

This is a non-covalent heterodimer, comprised of two non-identical components, GPIIb (CD41b), the alpha subunit with the higher molecular weight and GPIIIa (CD61) the beta subunit with the lower molecular weight. Both are synthesized as single chain polypeptides and processed by intracellular proteolysis to form two-chain molecules consisting of a heavy chain and a light chain.

GPIIb has a molecular weight of 140kDa on polyacrylamide gel electrophoresis. Due to extensive intrachain disulphide bonds, the molecular weight of GPIIIa increases on reduction (Phillips and Agin, 1977a, 1977b), from 95kDa to 108kDa.

Both are found as components of a single immunoprecipitate on crossed immunoelectrophoresis (CD41a) of normal platelet membrane extracts (Hagen et al, 1980). They also co-purify on affinity chromatography in Triton X-100 when using an immobilized monoclonal antibody directed towards one of them (McEver et al, 1983). Both are genetically absent from the platelets of patients with the inherited bleeding disorder - Glanzmann's Thrombasthenia, characterized by the absence of aggregation.

Approximately 50,000 copies of the GPIIb/IIIa complex are expressed on each platelet, constituting 15-20% of the total membrane protein. Two domains are found on rotatory shadowing electron microscopy: a globular head domain with two rod-like tails extending from either side (Carrell et al, 1985).

GPIIb/IIIa has a number of functions:

- It carries the unique determinant for the human alloantigen, PL^{A1} (Newman et al 1989);
- it is the receptor for fibrinogen, which is greatly enhanced following ADP activation (Gogstad et al, 1982). As reviewed by Peerschke (1985), this site is unavailable on resting platelets;
- Four sequences of 12 amino acids each, similar to the calcium-binding turns of calmodulin have been identified within GPIIb, and have been predicted to be the Ca²⁺-binding sites for the GPIIb/IIIa complex (Poncz et al, 1987).

Studies defining the molecular alterations of GPIIb/IIIa following on ADP stimulation to induce fibrinogen binding, have been reviewed by Berndt and Caen (1984). The combined evidence indicates that the bivalent fibrinogen molecule bridges GP IIB/IIIa molecules on adjacent platelets in a Ca²⁺-dependent manner.

A number of studies using platelets from patients with Glanzmann's Thrombasthenia provide convincing evidence that GPIIb/IIIa is the major receptor for adhesive proteins. Their membranes have a marked deficiency in their capacity

to bind fibrinogen (Bennet and Vilaire, 1979), fibronectin (Ginsberg et al, 1983) and von Willebrand factor (Ruggeri et al, 1982).

2. The Vitronectin Receptor (CD51/CD61)

In comparison to glycoprotein IIb/IIIa, this is a minor integrin on platelets. The alpha subunit (CD51) forms a Ca^{2+} -independent complex with the beta subunit (CD61), which is identical to GPIIIa (Lam et al, 1989). The receptor is known to bind the RGD-containing adhesive proteins vitronectin, fibronectin, vWf (Cheresh et al, 1987) and thrombospondin (Lawler and Hynes, 1989). This does not require platelet activation.

All the adhesive proteins mentioned above, including fibrinogen, have been shown to contain the critical RGDS sequence (Rousslahti and Pierschbacher, 1987). Significant identity of the amino acid sequences between members of this group have been found, as deduced from cDNA sequences. The RGD recognition specificity in the binding of ligands has been demonstrated for all three members of the Integrin superfamily. Members of the cytoadhesin family, particularly GPIIb/IIIa, exhibits high affinity for RGD (Pytela et al, 1986). The VLA family has the same recognition specificity, but their affinity is less than that of the cytoadhesins (Ginsberg et al, 1987).

THE NON-INTEGRIN GLYCOPROTEIN RECEPTORS

1. Glycoprotein Ib (CD42b/CD42c)

This glycoprotein together with GPIX and GPV, are members of the leucine-rich receptor family. Members include a variety of proteins with no apparent functional similarity, but share a common structural motif, composed of a leucine-rich, 24-amino acid consensus sequence (Takahashi et al, 1985).

GPIb consists of two disulphide-linked polypeptide chains, Ib alpha (CD42b) with a molecular weight of 143kDa, and Ib beta (CD42c) with a molecular weight of 22kDa, both of which are transmembrane proteins. Crossed immunoelectrophoresis of Triton-solubilized platelets with anti-glycocalicin antisera produces two peaks: glycoprotein Ib and a faster migrating peak, glycocalicin, a Ca^{2+} -dependent protease degradation product of GPIb (Solum et al, 1980). Studies using proteolytic enzymes have yielded important information on the structure of the alpha chain (Pepper and Jamieson, 1969; Berndt and Caen, 1984). Ca^{2+} -dependent protease cleavage splits off glycocalicin, with a molecular weight of 140kDa, leaving a residue which is linked to the beta chain. Trypsin cleaves glycocalicin to yield a highly glycosylated macroglycopeptide (118kDa), leaving a sugar-poor tail with a molecular weight of 45kDa, which is the platelet receptor for von Willebrand factor and thrombin.

The role of GPIb in the von Willebrand factor-dependent adhesion of platelets to exposed vascular endothelium was clearly demonstrated. (Meyer and Baumgartner, 1983). Its role as a receptor for thrombin remains controversial, as reviewed by Greco and Jamieson (1991). Studies have provided evidence of a high affinity pathway for thrombin-induced platelet activation which is GPIb-dependent, and which is immunologically distinct from another GPIb-independent system (Yamamoto et al, 1991). The monoclonal antibody TM60, directed against the thrombin-binding domain of GPIb only inhibited this process by 50%, indicating the existence of a separate GPIb-independent system. This is supported by the previous finding that platelets from which the thrombin-binding portion domain was removed from the membranes with the use of *Serratia marcescens* protease, continue to be activated by alpha-thrombin, but required a four-fold increase in the concentration (Harmon and Jamieson, 1988). Recently, a thrombin receptor has been cloned which is probably the key component of the GPIb-independent system,

interacting synergistically with the GPIb receptor to achieve optimal platelet activation (Vu et al, 1991). It is a member of the seven-transmembrane domain family, with the sequence LDPR⁴¹/S⁴²FLLRN at the amino-terminal exodomain. Thrombin cleaves the Arg⁴¹/Ser⁴² peptide bond, to unmask a new terminus beginning with the sequence SFLLRN. The later work of this group demonstrated that once unmasked, it is able to bind to the receptor, to effect its activation, thus functioning as a tethered intramolecular peptide ligand (Chen et al, 1994)

GPIb is highly complexed to a low molecular weight (22kDa) glycoprotein, GPIX. These, together with another glycoprotein, GPV (82kDa), are absent in the Bernard-Soulier syndrome (Berndt et al, 1983). This is a hereditary bleeding disorder characterized by a prolonged bleeding time, and thrombocytopenia with abnormal and large platelets.

2. Glycoprotein IX (CD42a)

This has a molecular weight of 22kDa, and is tightly but not covalently linked to GPIb (complex: CD42), appearing as an elongated dumbbell-shaped complex. A large globular domain is inserted in the plasma membrane, with a smaller globule external to the membrane (Fox et al, 1988) The complex is co-immunoprecipitated by antiplatelet, quinidine-dependent antibodies (Chong et al, 1983). This accounts for the thrombocytopenia that some patients develop whilst on quinine or quinidine therapy. The platelets of patients with the Bernard-Soulier syndrome fail to react with quinine/quinidine drug-dependent antibodies (Kunicki et al, 1978), providing evidence that the complex is the receptor for this antibody.

This complex also binds vWf, allowing the adhesion of unstimulated platelets to the subendothelium of damaged vessels. They stop, then anchor the platelet to the

subendothelium under the high shear conditions within the microcirculation.

3. Glycoprotein V

This membrane component (MW 82kDa) is a substrate of enzymatic activity of thrombin. Berndt and Phillips (1981) demonstrated that it was the only detectable membrane surface protein hydrolysed by thrombin, which preceded platelet aggregation. However, subsequent studies have demonstrated thrombin-induced platelet activation despite its prior removal by chymotrypsin (McGowan and Detwiler, 1986), or pretreatment with antibodies to GPV which prevents its cleavage by thrombin (Bienz et al, 1986). This glycoprotein is also genetically absent from platelets of patients with the Bernard-Soulier syndrome (Berndt et al 1983).

4. Glycoprotein IV (CD36)

This is a single chain structure with a molecular weight of 88kDa, which has been identified on the membranes of platelets (Tandon et al, 1989a). With the use of monospecific antibodies, aggregation and adhesion studies, it has been found to mediate the early stages of recognition and attachment to collagen (Tandon et al 1989b). The adhesion step, when examined in the micro-titre assay, was shown to be inhibited by F_{ab} fragments of monospecific polyclonal anti-GPIV antibodies. These studies also suggested a second GPIV-independent mechanism for subsequent anchorage of the platelets to the collagen. As indicated above, the GPIa-IIa complex is also involved in platelet spreading on collagen (Santoro 1986), with specificity to Type I and Type III collagen (Kunicki et al, 1988). Similarly, the anti-GPIV antibodies have been shown to inhibit the interaction of platelets with thrombospondin (Asch et al, 1987), an adhesive protein contained within platelets, required for their irreversible aggregation.

5. The Selectins: GMP 140 (CD62P)

These comprise a family of cell surface receptors with an amino-terminal lectin-like domain, an adjacent epidermal growth factor-like domain, and multiple short consensus repeat units in tandem, homologous to the complement proteins. These receptors have a transmembrane component and a short cytoplasmic tail (Johnson et al, 1989). GMP 140, also called PADGEM or CD62P is a single polypeptide of 140,000MW which has been identified as a constituent of the alpha granule membranes of platelets (Stenberg et al, 1985). It is minimally expressed in the resting state, but appears on activation and alpha granule secretion (Hsu-Lin et al, 1984). It is considered to be a substrate for the binding of a wide variety of leucocytes, mediating their interaction with platelets in the cellular reaction to inflammation and haemorrhage (Johnson et al, 1989).

6. The Immunoglobulin Gene Superfamily

This group is composed of subfamilies of glycoproteins involved mainly in cellular recognition and share the homology unit. Two members have been identified on the membranes of platelets: The HLA class I molecules and PECAM-1 (CD31) a 130kDa glycoprotein (Newman et al 1990), with immunoglobulin domains similar to those of the cell adhesion molecule (CAM) subfamily, and thus likely to be involved in cellular interactions (Williams and Barclay, 1988)

LAMININ

This is a major component throughout the basement membrane (Timpl et al, 1979), where it, together with type IV collagen, constitutes the major components, in association with proteoglycans and other glycoproteins like fibronectin, von Willebrand factor and thrombospondin. For experimental use, laminin is extracted from Engelbreth-Holm-Swarm (EHS) sarcomas grown in lathyrotic mice, which produces abundant amounts of basement membranes.

It is a glycoprotein having both a structural and a biologically active role (Timpl et al, 1979; Engel et al, 1981; Rao et al, 1983), with a molecular weight of about 1,000kDa in the unreduced state, and produces two components of molecular weight 200kDa and 400kDa under reducing conditions. It consists of three large polypeptide chains designated B1 (215kDa), B2 (205kDa) and A (400kDa) (Cooper et al, 1981). By means of many inter- and intra-chain disulphide bonds, these components form a cross shape in the natural state of the molecule, with a long arm (75nm.) and three short arms (30nm.) as seen in rotatory- shadowing images (Engel et al, 1981) (Plate 1).

The four ends of the cross shape are globular, consisting of mainly carbohydrate. The intersection is protease resistant, containing numerous disulphide bonds, and is the binding site for the receptor of malignant and other cells. A single polypeptide called nidogen forms a stable complex with laminin, and the two are invariably associated within tissues. Nidogen was isolated from extracts of EHS tumour (Timpl et al 1983), and later shown to be a single polypeptide, dumbbell-shaped, with a molecular weight of 150kDa (Paulsson et al 1986). One molecule binds through one of its globular domains to the centre of the intersection of the polypeptide chains. The biologic significance of this association is unknown (Martin and Timpl, 1987).

The complex of the two molecules in their natural state is seen in Plate 1, and a schematic model of the association is illustrated in Plate 2.

Plate 1. In vitro laminin structure.

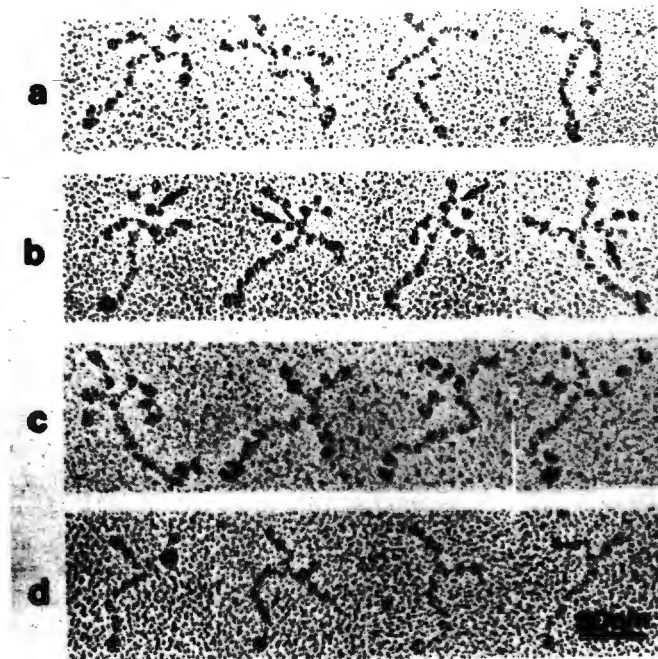

Rotary-shadowing images of laminin from mouse EHS tumour (top) sea urchin embryo culture (third from top) rat Schwannoma cell culture (bottom) and of particles of the laminin-nidogen complex from EHS tumour (second). The probable position of the noncovalently attached, dumbbell-shaped nidogen is indicated with arrows. (From Martin and Timpl, 1987).

Plate 2. Model of laminin structure.

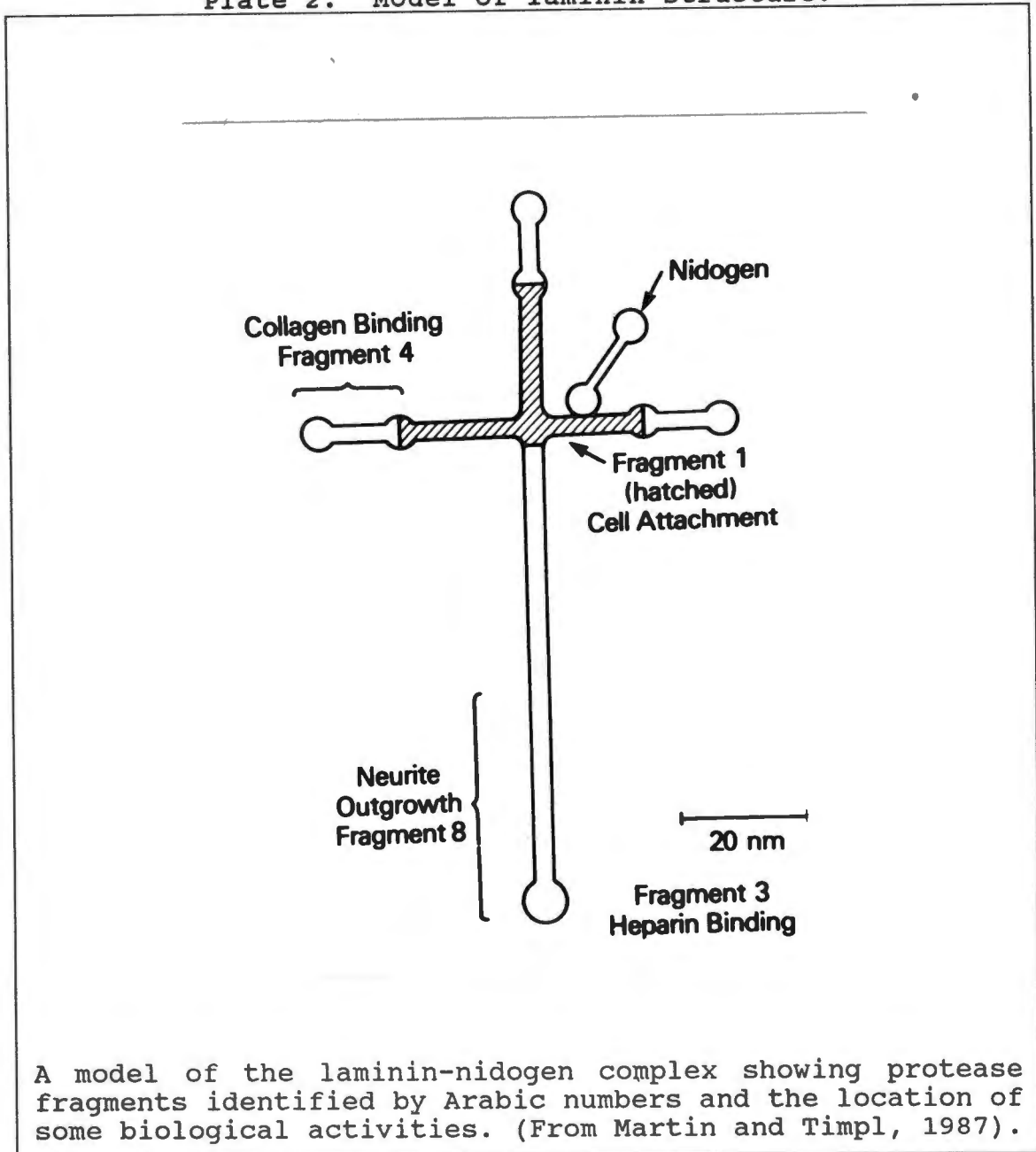

Recent computer analysis of cDNA clones have established the amino acid sequence of the multidomain structure of the B1 chain (Sasaki et al, 1987). The N-terminal domains, VI and IV have a low cysteine content and forms the globular structures. Domain V has five cysteine-rich segments of about 50 amino acids, separated by gaps, whereas domain III has eight and contains the important sequence YIGSR that

supports cell attachment, chemotaxis, and binding to the 67kDa receptor of tumour cells (Graf et al, 1987). The C-terminal domains II and I have an alpha-helical structure. The B2 chain has a similar structure. The Ae, B1e, and B2e chains of laminin have since been fully sequenced (Sasaki et al, 1988). The intersection of the three chains, is kept intact by disulphide bonds. They then run together, in parallel, to form the rod-like segment of the long arm. The carboxyl terminus of the A chain forms the large globule at the end of the long arm. A schematic model of the arrangement of the three chains is illustrated in Plate 3. Binding to laminin elicits specific responses, causing secretory cells to become polarized (Hadley et al, 1985), those of neural origin to extend axon-like processes (Baron van Evercooren et al, 1982), and others to migrate (McCarthy et al, 1983). In cultures growth is strongly enhanced, with survival and differentiation facilitated (Kleinman et al, 1985). The long arm binds heparin and stimulates neurite outgrowth (Engvall et al, 1986), whilst the globular end regions of the short arms promote cell spreading, bind to plasma membrane sulphatides and to Type IV collagen (Rao et al, 1982).

On consideration of its wide range of biological activity, the finding that tumour cells are rich in specific receptors for this unique glycoprotein (Terranova et al, 1983) suggests that these properties are active in the promotion of neoplastic growth and metastasis.

Plate 3. Model of chain arrangement.

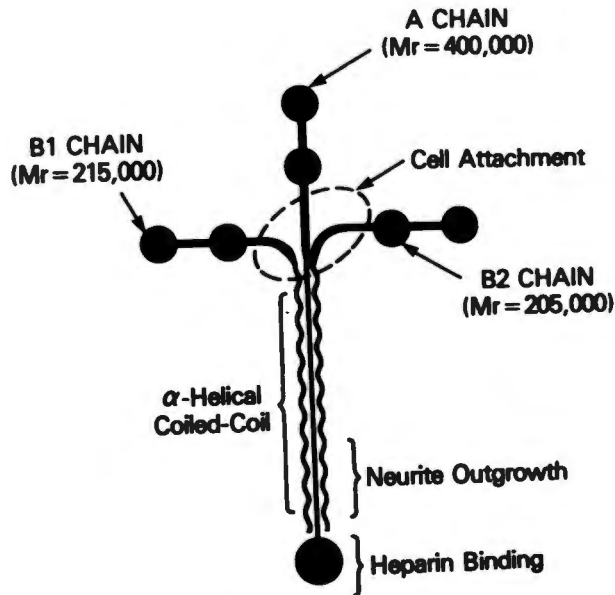

Arrangement of the A, B1 and B2 chains in the laminin molecule. (From Martin and Timpl, 1987).

LAMININ RECEPTORS

Liotta has reviewed the work produced in his laboratory in isolating binding sites for laminin on the membranes of breast carcinoma cells (1986). The latter had a density of up to 100,000 molecules, are specific and of high affinity. Laminin-affinity column separation yielded a 67kDa peptide containing intrachain disulphide bonds, with an isoelectric pH of 5.2. Identical isolates were eluted from murine fibrosarcoma cells by Malinoff and Wicha (1983) and from murine muscle by Lesot et al (1983). Monoclonal antibodies

to the receptors recognize the corresponding component of a breast carcinoma membrane extract. Recent work by Wewer et al (1986) has detailed its amino acid sequence, deduced from molecular cloning studies. Receptor m-RNA was shown to be 1,700 bases long. A schematic model showing the various residues of the the B1 chain of the laminin molecule recognized by the 67kDa receptor (Graf et al, 1987), is shown in Plate 4.

Plate 4. Model of chain molecular arrangement.

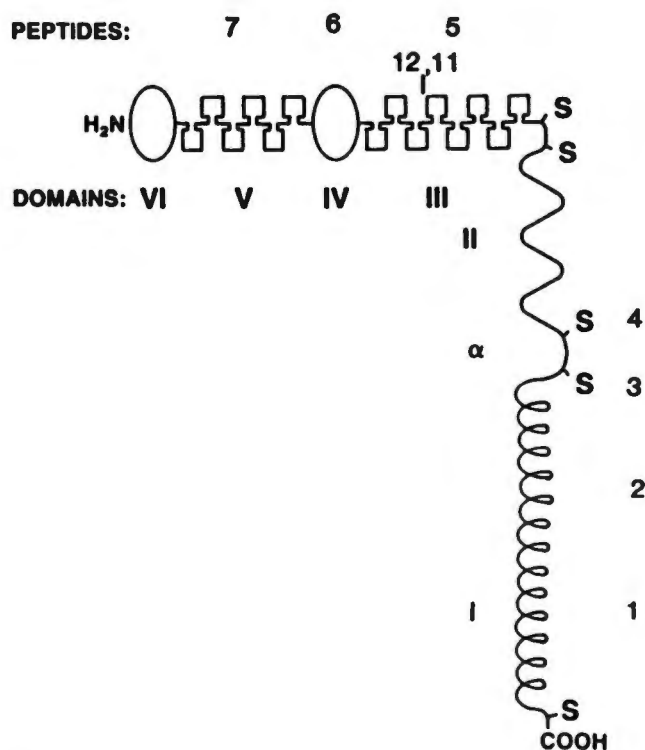

Schematic model of the laminin B1 chain. The Roman numerals designate the structural domains as derived from computer analysis of the deduced amino sequence. The Arabic numbers designate the locations of synthetic peptides. The peptides and their respective residue numbers in laminin are: peptide 1, residues 1593-1611; 2, residues 1509-1529; 3, residues 1395-1416; 4, residues 1363-1383; 5, residues 960-978; 6, residues 615-634; 7, residues 364-385; 11, residues 925-933; 12, residues 903-912. (From Graf et al, 1987).

A cysteine-rich residue of the B₁ chain which contains the amino acids sequence: Cys-Asp-Pro-Gly-Tyr-Ile-Gly-Ser-Arg at positions 925 to 933 is the cognate site for the 67kDa receptor. Functional aspects of these receptors on metastatic capacity was demonstrated by Barsky et al (1984b) using a murine model. Treatment of the cells with the receptor binding fragment of the laminin molecule, markedly inhibited or abolished metastases in a non-toxic fashion.

PRIOR STUDIES ON THE PLATELET LAMININ RECEPTOR

Using laminin-coated petri-dishes, Ill et al (1984) demonstrated adhesion of resting radio-labelled platelets. No evidence of release or aggregation was found and the cells remained rounded when examined by electron microscopy. These findings were in contradistinction to those with binding to fibronectin where they developed a flattened-out appearance, and the release of radio-labelled serotonin when bound to collagen.

A constant fraction of the suspension was found to adhere to laminin when the unbound platelets were transferred to a second set of similarly prepared dishes. This indicated that it was not merely a sub-population that was binding. The adhesion was inhibited in the presence of anti-laminin antibodies but not by the RGDS peptide.

Later adhesion studies using a similar approach was carried out on micro-titre plates by Sonnenberg et al (1988). They showed it to be supported by magnesium- as well as manganese- and cobalt-ions but not by calcium-, zinc- or copper-ions. Monoclonal antibodies to VLA-6 were shown to inhibit binding to laminin while the adhesion to plates coated with fibrinogen, fibronectin or collagen remained unaffected. It was thus concluded that the specific VLA-6 receptor is distinct from the well established 67kDa

receptor on human breast carcinoma cells (Terranova et al, 1983). As mentioned above, these cells recognise the Cys-Asp-Pro-Gly-Tyr-Ile-Gly-Ser-Arg peptide of the B1 chain of the molecule. The authors claim that this peptide did not inhibit platelet adhesion in their model. The data from which they drew this conclusion unfortunately was not presented.

Subsequent work by the same group using ligand affinity chromatography with the E8 fragment of the long arm of laminin bound to the affinity column, isolated a complex of two polypeptides of 140 and 110kDa from radiolabelled platelet lysates. The complex was identified as VLA-6 by immunoprecipitation with specific antibodies to the alpha-6 and beta-1 components (Sonnenberg et al, 1991). However, when the P1 laminin fragment, derived from the short arm was linked to the Sepharose column, the alphaII/beta₃ (GPIIb/IIIa) platelet integrin (which did not bind to the E8 affinity column) was eluted, and no VLA-6 was evident.

The binding of platelet lysates to columns to which the complete laminin molecule was linked, as was used in the present study, was not examined.

I CHARACTERIZATION OF PLATELET ADHESION TO LAMININ

A. DEVELOPMENT OF A MICRO-TITRE ASSAY FOR MEASURING PLATELET-LAMININ INTERACTION

INTRODUCTION

A model was developed to study adhesion under varied conditions, whereby radio-labelled platelets were allowed to attach to the surface of micro-titre wells coated with laminin. The unattached cells were aspirated off and the remainder lysed with SDS. Adhesion was then calculated by measuring the amount of radio-label in the lysate.

OPTIMIZATION OF THE MICRO-TITRE ASSAY

Conditions were standardized, including:

- the coating of the surface;
- the selection of a suitable concentration of platelets;
- the duration of incubation;
- the optimal cation concentration for the suspension buffer; and
- the demonstration of the specificity of the interaction with the use of anti-laminin antibodies.

Preparation of laminin-coated surface

Flat bottomed microwell plates with high binding capacity (Nunc-Immuno plate, Maxisorp, 6mm diameter, Nunc, Denmark) were used to obtain a solid phase. The wells were coated by incubation with 50ul of a solution of laminin, (whole glycoprotein isolated from the basement membrane of the Engelbreth-Holm-Swarm transplantable murine tumour - Collaborative Research, Bedford Mass.) at room temperature until needed.

Preparation of platelet suspension

Whole blood was obtained from volunteers, anticoagulated with CPD-A1 at a ratio of 6:1 of blood to CPD-A1. Platelet-rich plasma (PRP) was obtained by low speed centrifugation at 800xg for 10 minutes at 22°. PGE₁ (Sigma Chemical Co., St. Louis, Mo.) at a concentration of 1ug/5ml was added to the PRP, the pH adjusted to 6.5 with citric acid. The cells were then sedimented by centrifugation at 1,800xg for 10 minutes, resuspended and washed twice in citrate wash buffer (5.5mM dextrose; 120mM NaCl; 4.26mM NaH₂PO₄; 7.46mM Na₂HPO₄; 4.77mM trisodium citrate; 2.35mM citric acid, with 0.35% BSA at pH 6.5). Following resuspension in buffer A (5.0mM tris; 5.5mM glucose; 150mM NaCl; 2.0mM MgCl₂) containing 0.5% BSA at pH 7.4 at a concentration of 1x10⁹ per ml as determined by counting in a Coulter counter (Coulter Electronics, Hialeah, FL), they were labelled with Na₂[⁵¹Cr]O₄ (50uCi/ml) (Amersham Corporation, IL - 250mCi/mg) by incubation at room temperature for 1 hour in buffer A. Finally, the labelled preparation was washed and resuspended in buffer A at a concentration of 5x10⁸/ml

Assay of platelet adhesion

The excess laminin was aspirated from the wells and 250ul of tris saline buffer A with 0.5% BSA at pH 7.4 was added to each well for 30 minutes to block unoccupied sites on the bottom of the wells. The blocking buffer was aspirated off, 50ul of the labelled suspension was then added in triplicate, and incubated at room temperature without rocking. After 60 minutes, the wells were aspirated and then washed twice with buffer A to remove the free cells. Adhesion was determined by lysing the adherent population, using 100ul of 2% sodium dodecylsulphate (SDS) in water for 30 minutes. The lysate from each well was individually collected and the ⁵¹Cr content determined in a gamma counter (Autogamma 5000 series, Packard Instruments, IL).

1. LAMININ CONCENTRATION

Aim:

To define surface conditions for optimal and consistent adhesion.

Methods:

A range of concentrations from 40-320ug/ml in buffer A (without BSA) was prepared. 50ul of each was applied to the micro-titre wells in triplicate, to provide a range of 2ug-16ug/well. The plates were then left at room temperature until they were needed.

After a radio-labelled platelet suspension of 5×10^8 /ml was prepared, the excess laminin solution was then aspirated and the wells blocked with buffer A. 50ul of the platelet suspension was added to each well in triplicate. After 60 minutes the excess cells were aspirated off and those adherent lysed with SDS. The radioactivity of each lysate was then determined as described above. The ^{51}Cr content of the lysates was determined with a mean blank value derived from uncoated wells, which was subtracted from the mean of the triplicate experimental values.

Results and comment:

The results indicate that there is an increase in adhesion as the concentration of laminin increases, as shown in Fig.1.

The increase was rapid up to a concentration of 2ug/well (40ug/ml) but with a more gradual linear rise thereafter, appearing to reach a steady state. At the concentration selected for future assays, 8ug/well, there was a mean adhesion of 35×10^5 /ml (SE = 1).

Fig.1.

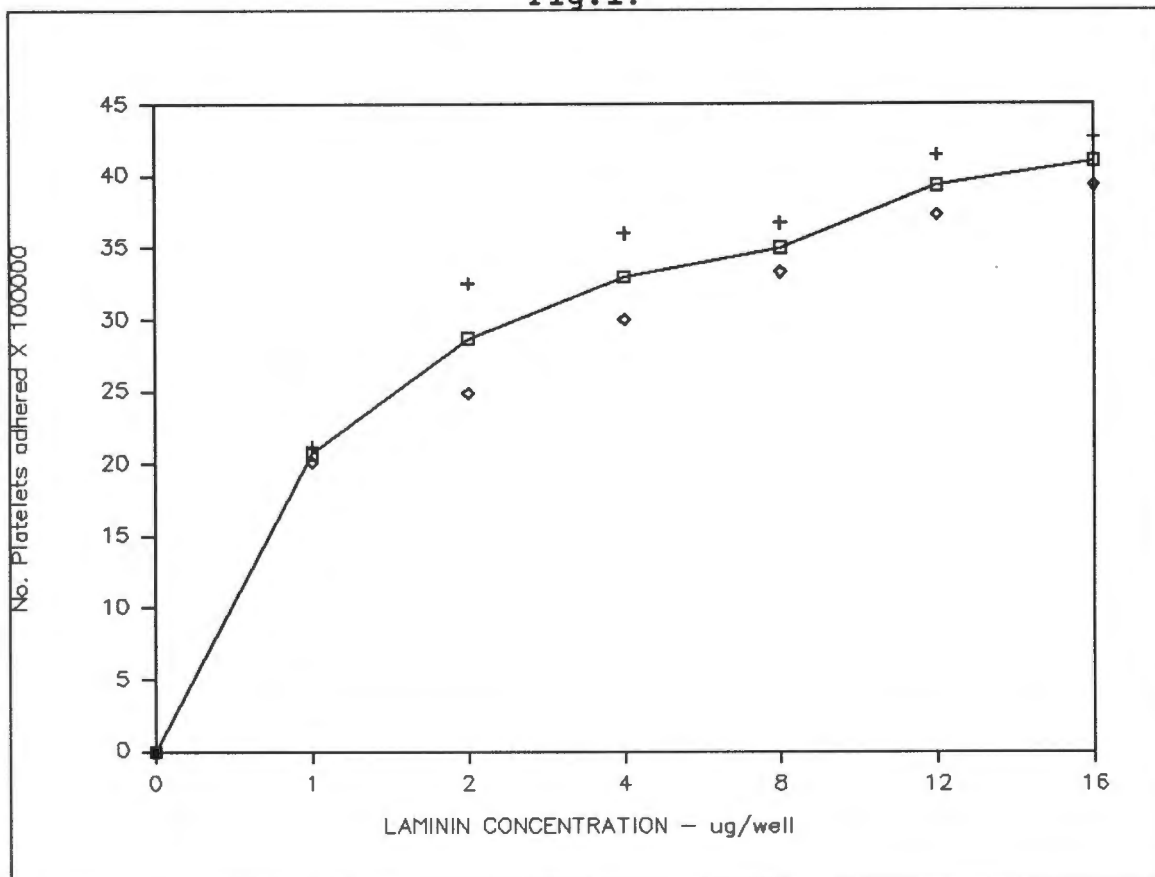

Number of platelets bound to various concentrations of laminin. Each point represents the mean value of three studies, each done in triplicate, using the platelets of the same donor on different days, plus/minus the Standard Error as indicated.

These findings are similar to those of Ill et al (1984), who used laminin-coated petri dishes and a platelet concentration of 2×10^8 /ml. Again a linear relationship with increasing laminin was demonstrated, up to a concentration of 30ug/ml. They used 30-40ug/ml for the solid phase in subsequent experiments.

The tailing off of the increase in binding occurred at a lower laminin concentration in the study of Sonnenberg et al (1988). Greiner micro-titre plates were used, with a platelet concentration of 1×10^8 /ml. The increase in binding was rapid up to a concentration of 10ug/ml, slowing between 10ug/ml and 20ug/ml and very little increase thereafter.

They used 20ug/ml in their adhesion studies. No detail of the well geometry (flat or round bottomed) is provided, which may account for the this difference in the pattern of adhesion.

Conclusion:

Adhesion showed minor variation for laminin concentrations above 40ug/ml. A concentration of 160ug/ml (8ug/well) for the solid phase was thus considered satisfactory for optimal adhesion in all subsequent experiments.

2. PLATELET CONCENTRATION**Aim:**

To establish a suitable suspension for the study of variable degrees of adhesion.

Methods:

The micro-titre wells were coated with 8ug/well of laminin and left at room temperature until needed.

Whole blood was drawn into CPD-A1, PRP was prepared, and the cells labelled as described. Labelled concentrates ranging from 1×10^6 /ml to 1×10^9 /ml were prepared.

The wells were aspirated to remove the excess coating solution. Buffer A was added to block uncovered sites on the surface for 30 minutes and then aspirated. 50ul of each cell concentration was applied in triplicate, providing a range of 5×10^5 to 500×10^5 /well. Binding was allowed for 60 minutes, after which the unbound cells were aspirated.

The plates were washed twice with buffer to remove unbound cells and those adherent were then lysed with SDS, their number calculated from the ^{51}Cr content of each well. The ^{51}Cr content of 50ul of each concentration was equated with the total number of cells added. The number adherent was

calculated from the mean ^{51}Cr value at each concentration, as a proportion of the ^{51}Cr content of the platelets added.

Results and comment:

The adhesion increased, with a steep rise starting at $1 \times 10^8/\text{ml}$. These values are shown in Fig.2.

At a concentration of $5 \times 10^8/\text{ml}$ the mean adhesion was $47.23 \times 10^5/\text{ml}$ (SE = 2.41). This point is noted to fall on the rapidly rising part of the curve. It is thus reasonable that any experimental condition that promotes or inhibits adhesion will cause well defined changes in the assay.

Fig.2.: Platelet concentration.

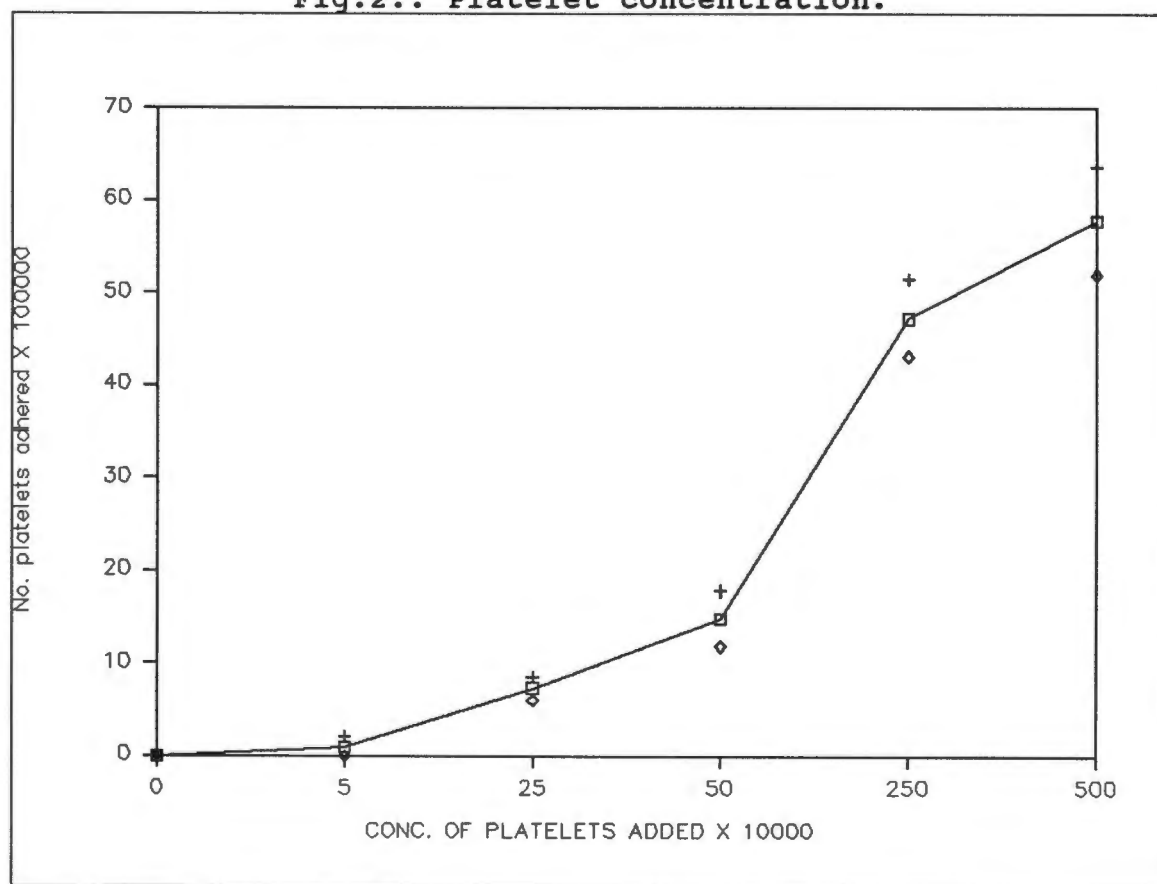

Number of platelets bound ($\times 10^5$) with increasing concentrations of platelet suspension ($\times 10^5/\text{ml}$) added. Each point represents the mean value of three studies, each done in triplicate, using the same donor on different days, plus/minus the Standard Error as indicated.

Conclusion:

The platelet concentration of 5×10^8 /ml is suitable for examining variable adhesion and all subsequent studies were standardised accordingly.

3. DURATION OF INCUBATION OF PLATELET SUSPENSION WITH LAMININ**Aim:**

To determine the duration of cell interaction with the laminin solid-phase to allow for optimal adhesion.

Methods:

The micro-titre wells were coated with 8ug/well of laminin and blocked with buffer A at room temperature until needed. Whole blood was drawn into CPD-A1, PRP was prepared, the platelets were labelled as described.

The wells were aspirated to remove the excess buffer A and 50ul of the suspension at a concentration of 5×10^8 /ml was applied in triplicate. The cells were allowed to bind for periods varying from 2-60 minutes, after which those unbound were aspirated.

The plates were washed twice with buffer A to remove unbound cells and the bound fraction lysed with SDS. The number of adhered platelets were then calculated from the ^{51}Cr content of each well. The ^{51}Cr content of the 50ul of the suspension was measured as the total number of platelets added. The number adhered was calculated from the mean of the three ^{51}Cr values of the lysates as a proportion of the ^{51}Cr content added.

Results and comment:

Adhesion increased rapidly with increasing duration of the incubation time, up to 60 minutes, after which there was a minimal increase up to 90 minutes as seen in Fig.3.

A reproducible lag phase in the first 5-10 minutes was noted.

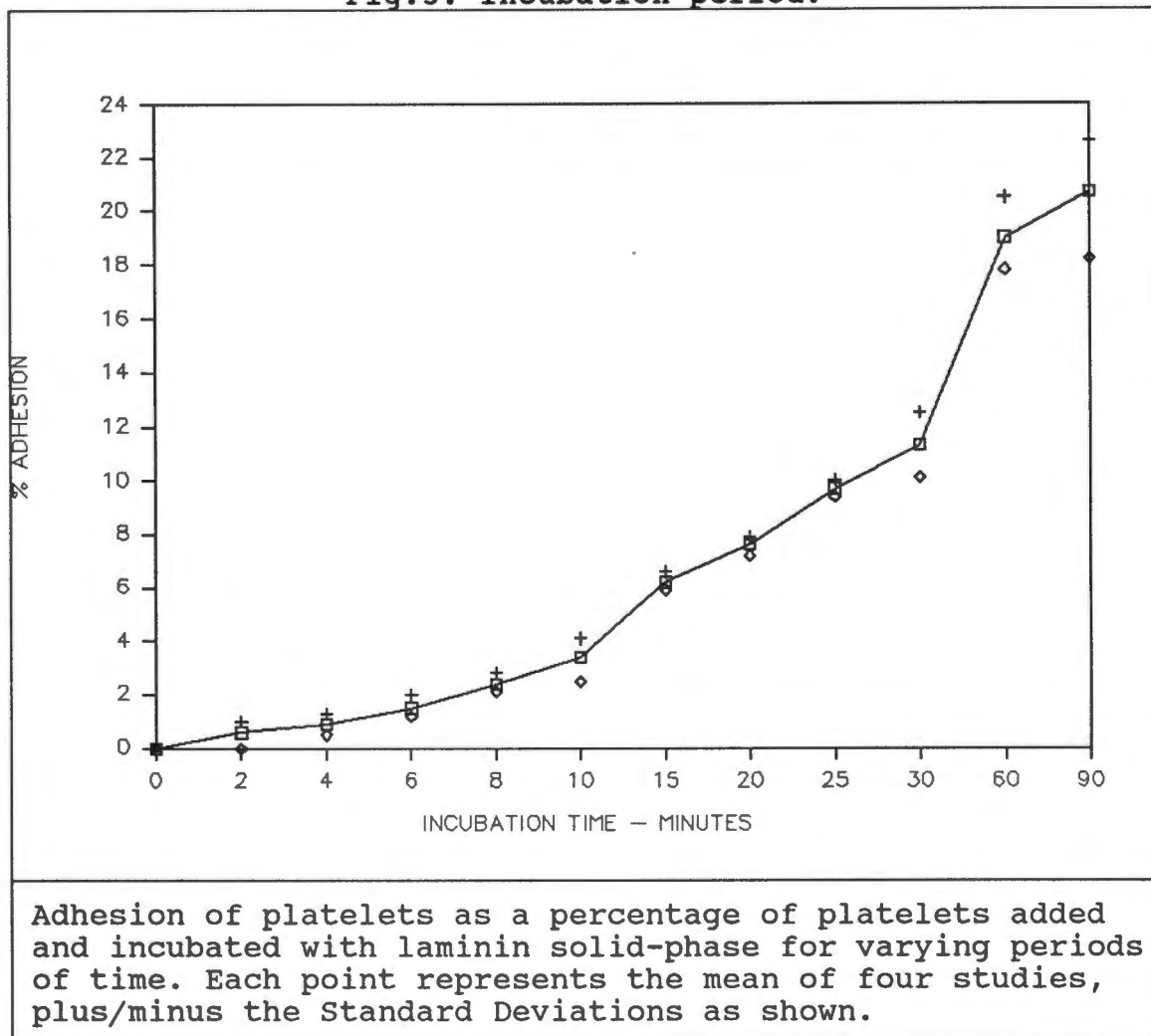
Fig.3. Incubation period.**Conclusion:**

Optimal adhesion occurs at an incubation time of 60 minutes. This time was used for all subsequent studies.

4. CATION REQUIREMENT

Introduction:

Divalent cations are known to have an important influence on adhesion. Their removal by means of EDTA prevented platelet interaction with the non-collagen matrix of glomerular basement membranes (Huang and Benditt, 1978). Removal of Ca^{2+} and Mg^{2+} from the suspending medium also abolished the ADP-mediated binding of fibrinogen to the GPIIb/IIIa platelet receptor (Mustard et al, 1978).

Early studies by Hovig (1964) on the adhesion of rabbit platelets to collagen were confirmed in later studies using human platelets (Cowan et al, 1981). These investigators used a collagen-Sepharose column formed by covalently linking collagen to cyanogen bromide-activated Sepharose, and demonstrated increased adhesion in the presence of 1mM Mg^{2+} . 1mM Ca^{2+} did not support adhesion. With the use of Type I collagen coupled to plastic slides, Shadle and Barondes (1982) demonstrated an absolute dependence of adhesion on Mg^{2+} , with Ca^{2+} having an inhibitory effect. 0.5 to 3mM of Ca^{2+} inhibited binding in the presence of 1mM Mg^{2+} . 1mM EGTA inhibited adhesion by about 90%, which was overcome by increasing Mg^{2+} concentrations. A similar effect of the strong chelator EGTA was demonstrated by Cazenave et al (1979). 4.5mM EGTA inhibited adhesion to the collagen coated surface to less than 10% of the control values.

It is thus evident from the marked inhibition of adhesion in the presence of EGTA, that the process is dependent on divalent cations. Although most studies have examined the effects of Ca^{2+} and Mg^{2+} , others also have an influence. This was studied by Sonnenberg et al (1988), who showed it to be poor in the presence of the chelator EDTA, supported by magnesium-, manganese- and cobalt-ions, but inhibited in the presence of calcium-, zinc- and copper-ions.

Aim:

To determine the influence of the two principal cations, Ca^{2+} and Mg^{2+} , in order to select an optimal concentration for the assay.

Methods:

The micro-wells were coated with laminin at a concentration of 8ug/well at room temperature. Whole blood was drawn into CPD-A1 and PRP was prepared.

The platelets were then labelled, washed and resuspended in Mg^{2+} -free buffer A. The resuspension buffer was supplemented with increasing concentrations of Mg^{2+} ranging from 0 to 2mM. In a second set of preparations, the buffers with an identical range of Mg^{2+} were supplemented with 0, 0.5, 1, and 2mM Ca^{2+} to provide an equimolar solution. A third set was prepared with identical concentrations of Ca^{2+} without Mg^{2+} . All platelet concentrations were adjusted to $5 \times 10^8/\text{ml}$. The excess coating solution was aspirated off and the wells were then blocked using buffer A without Mg^{2+} until they were ready for use. The wells were then aspirated to remove the blocking buffer, platelets from each suspension was added to the wells in triplicate, and the adhesion assay was then carried out as described above. Adhesion was expressed in terms of the ^{51}Cr content of the lysate from each well as a percentage of that in 50ul which was added.

Results and comment:

No adhesion occurred in the absence of divalent cations. It was strongly supported by Mg^{2+} at 0.5 mmol without any calcium (mean = 11.87%, SE = 0.62). Further increases in the Mg^{2+} concentrations produced smaller increments, appearing to reach a steady state at 2.0mM (mean = 15.63%, SE = 0.7). All concentrations containing only calcium-ions abolished adhesion. The inhibition of adhesion in the presence of calcium-ions was well demonstrated in the equimolar preparations of Ca^{2+} and Mg^{2+} . At all equimolar

concentrations a fixed proportion of platelets were bound, with means of 9.63% (SE = 0.37), 9.6% (SE = 0.27) and 9.7% (SE = 0.4) for the 0.5, 1 and 2mM equimolar concentrations respectively. The reason for this phenomenon is not clear, but may suggest competition at a cation binding site of the receptor. These results are shown in Fig.4.

Fig.4: Cation requirement.

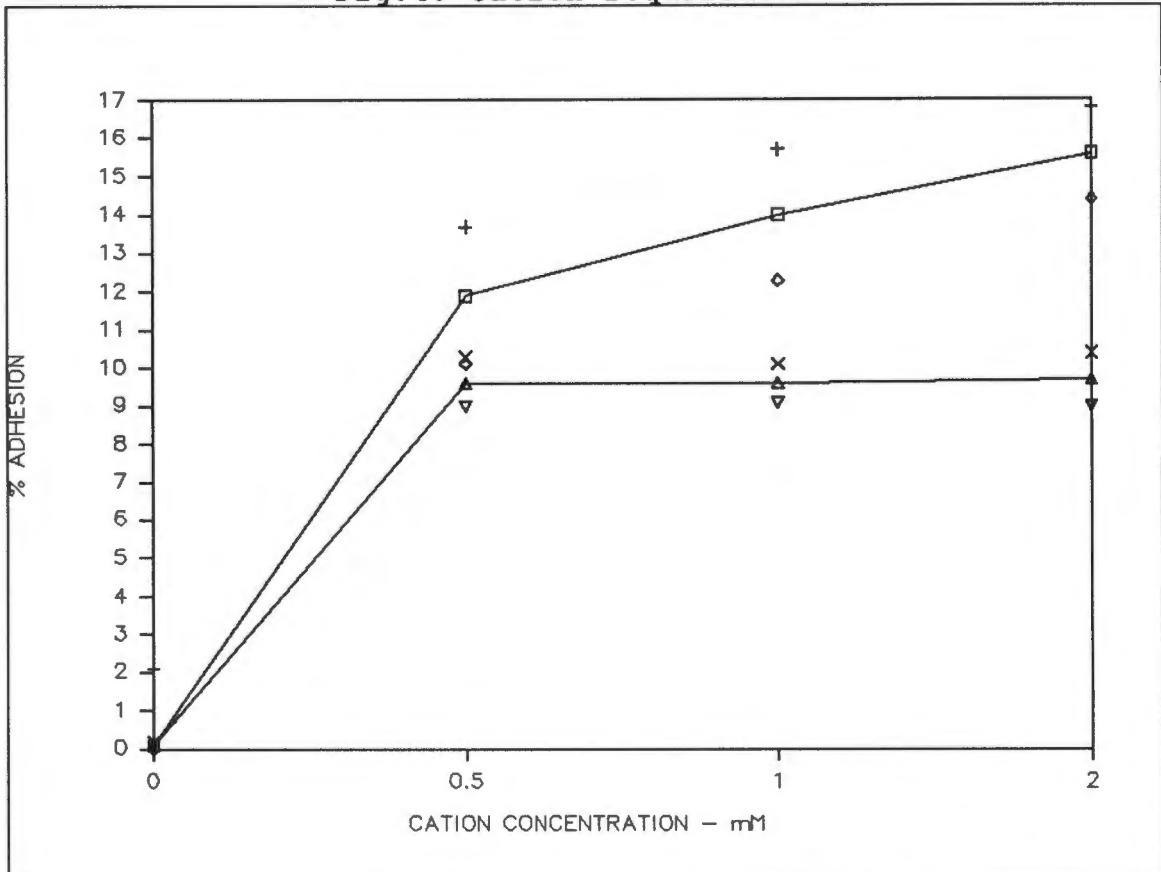

Platelet adhesion as a percentage of control in the presence of varying concentrations of cations present in the platelet suspension buffer. Top: Magnesium-ions. Bottom : Equimolar concentrations of magnesium- and calcium-ions. Each point represents the mean value of three studies, each done in triplicate, using the same donor on different days, plus/minus the Standard Error as indicated.

Conclusion:

Platelet adhesion to laminin is supported by magnesium- but strongly inhibited by calcium-ions. These results are consistent with those of Sonnenberg et al (1988) and mirror the conditions required for binding to collagen (Shadle and Barondes, 1982) and for fibronectin binding to platelets stimulated by thrombin (Plow et al, 1985). A calcium-free magnesium-ion concentration of 2mM was considered as suitable for all subsequent adhesion assays

5. SPECIFICITY**Introduction:**

Initial studies by Ill et al (1984) demonstrated the specificity of platelet adhesion to laminin-coated petri dishes with the use of polyspecific IgG. Pre-incubation of the coated surface with the antibody produced inhibition of platelet binding. These findings were confirmed by Sonnenberg et al (1988). In both these studies though, the complete IgG antibody molecule was used. Binding to laminin of the solid phase by means of the two F_{ab} portions of the molecule would leave the F_c portion free. As platelets possess membrane receptors for the latter, (Karas et al, 1982), binding via this mechanism could interfere with the demonstration of specific inhibition. In the present study this possibility was avoided with the use of F_{ab} fragments, thus retaining laminin recognition but without the this aberration.

Aim:

To demonstrate the specificity of platelet adhesion to laminin, by blocking the antigenic sites on the laminin of the solid phase with the use of anti-laminin F_{ab}, using control IgG F_{ab} fragments to exclude non-specific binding.

Methods:

F_{ab} fragments were prepared according to the methods obtained with the kit instructions of the manufacturer (Pierce Chemical Co. Rockford IL) from whom the immobilized papain and protein A was obtained. 0.5 ml of immobilized papain (pre-washed in buffer) was added to 10mg IgG rabbit antibody directed at mouse laminin (Collaborative Research, Bedford Mass.) in 1.0 ml freshly made 20mM NaH₂PO₄, 20mM cysteine-HCl, 10mM EDTA-Na buffer at pH 6.2. This was incubated for 5 hours at 37° with rocking. 3.0ml 10mM Tris-HCl at pH 7.5 was added, mixed and centrifuged. The supernatant was applied to a 5ml immobilized protein A column equilibrated with 10mM Tris-HCl, pH 7.5 and the column was washed with 5ml of the same buffer, collecting the eluate.

F_{ab} fragments (non-immune) were produced from chromatographically purified rabbit IgG (Cooper Biomedical Malvern, PA) using identical methods, to serve as controls. The micro-titre wells were coated with 8ug/well of laminin until needed. Whole blood was drawn into CPD-A1, PRP was prepared and labelled as described.

Increasing concentrations ranging 5-40ug/well (100-800ug/ml) of both the anti-laminin and the non-immune F_{ab} fragments were prepared.

The coated wells were blocked with buffer A for 30 minutes and then aspirated free of excess buffer A. 50ul of the F_{ab} preparations were added in triplicate. This was allowed to incubate for 30 minutes at room temperature. The wells were then aspirated free of excess antibody, 2.5×10^7 labelled cells were added to each well and adhesion assayed in the standard way. Adhesion was expressed as a percentage of that occurring without the presence of F_{ab} fragments.

Results and comment:

Adhesion was inhibited by 89% at an anti-laminin Fab concentration of 5ug/well, (mean adhesion was 10.97%, SE = 2.03). Complete inhibition was found at higher concentrations, as seen in Fig.5.

The Fab fragments of the control IgG Fab were without effect up to a concentration of 40ug/well. A non-specific effect of the anti-laminin antibodies was excluded in this way.

Fig.5: Specificity of assay.

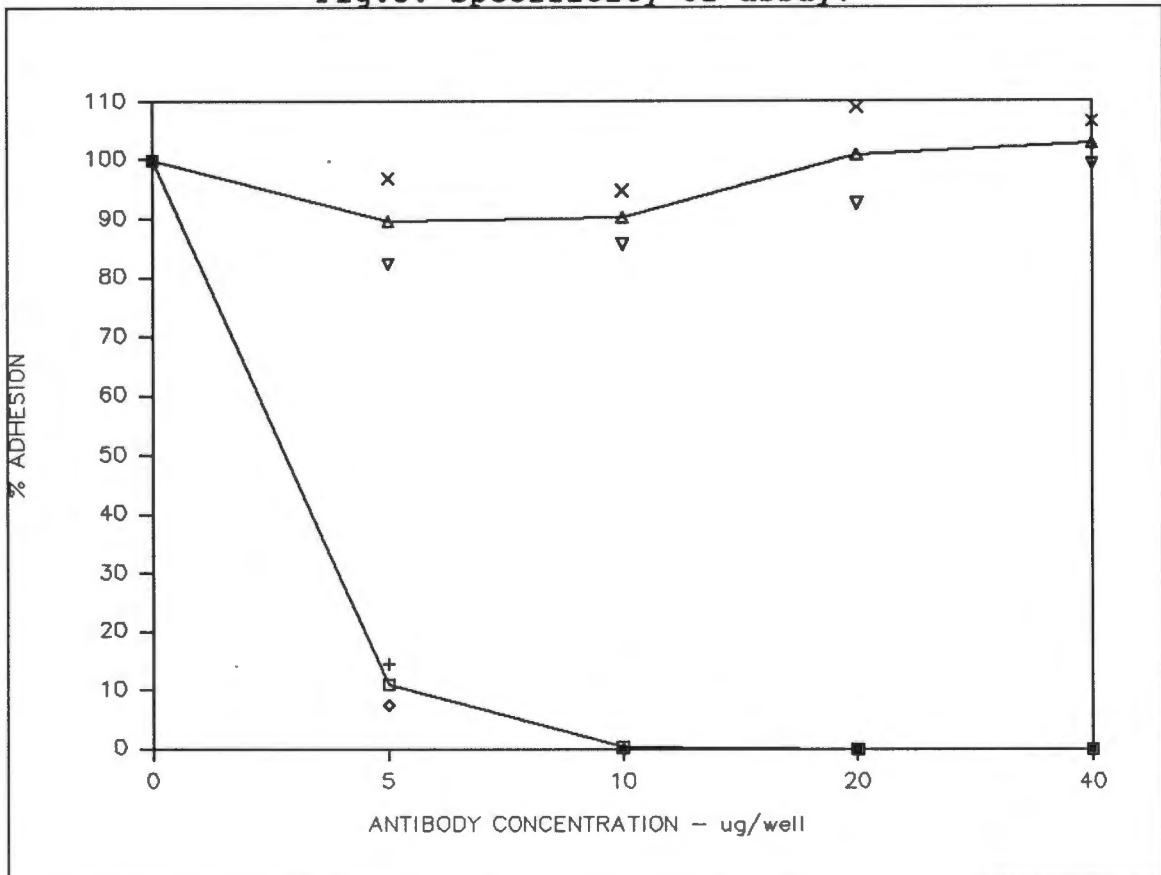

Platelet binding following incubation of the laminin-coated micro-wells with increasing concentrations of Fab fragments of anti-laminin IgG antibodies, expressed as a percentage of the total binding of platelets to antibody-free wells (bottom), with Fab fragments of an irrelevant antibody serving as controls (top). Each point represents the mean value of three studies, each done in triplicate, using the same donor on different days, plus/minus the Standard Error as indicated.

Conclusion:

The adhesion to laminin is mediated by specific membrane components of platelets.

6. DISTRIBUTION OF PLATELET ADHESION IN NORMAL VOLUNTEERS**Aim:**

To document the normal range of adhesion in the model, in order to establish its suitability for the study in normal randomly selected volunteers.

Methods:

Randomly selected healthy volunteers, on no medication within two weeks of the donation, were requested to donate blood samples for the platelet-laminin adhesion study, after being informed of its research nature. The percentage of platelets from a 5×10^8 /ml suspension that were bound in the assay carried out as described above was analysed for 32 subjects, 21 male and 11 female. The number of cells bound was expressed as a percentage of that added to each well.

Results and comment:

The percentage of adhesion ranged from 7.7-21% with a mean of 14.85, median of 14.65, and a standard deviation of 2.73 for the whole group. The distribution curve is thus unimodal, slightly skewed to the right, with a narrow variation about the mean. Adhesion ranged from 9.6-21% (mean of 15.49) for males and 7.7-17.1% (mean of 13.64) for females. These results are shown in Fig.6.

Conclusion:

These results were normally distributed, with acceptable variability and thus the assay is suitable for the study of platelet adhesion.

Fig.6.

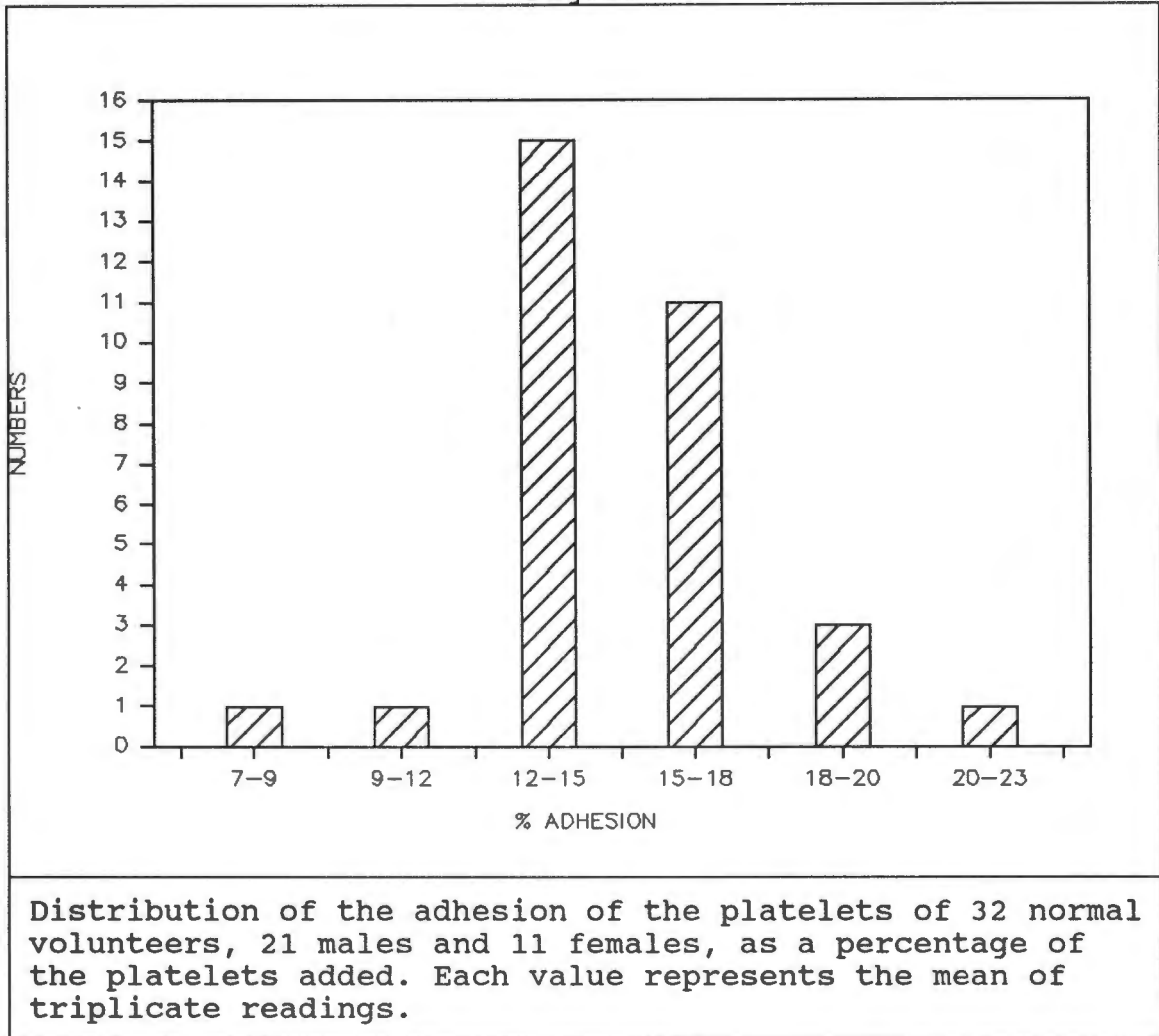

THE BINDING CHARACTERISTICS OF THE PLATELET LAMININ RECEPTOR - A SUMMARY

There exists a specific receptor for laminin on the membranes of human blood platelets, as demonstrated with the use of cognate antibodies. The specificity demonstrated in previous reports (Ill et al, 1984, Sonnenberg et al, 1988), was based on the use of the complete polyspecific immunoglobulin. Since the latter could interfere with the demonstration of laminin-specific inhibition, a modification was introduced to exclude such a non-specific effect. The

results of the present study, confirms the specificity of the process with the use of anti-laminin F_{ab} fragments.

The binding has distinctive characteristics. It is sensitive to the divalent cation concentration of the prevalent medium and platelets do not adhere in their absence, as shown with the use of EDTA by Sonnenberg et al (1988). These authors also show that the adhesion is supported by magnesium-, manganese- and cobalt-ions but not by calcium-, zinc- and copper-ions. These observations were extended in the present study by demonstrating a 38% inhibition of adhesion when platelets were suspended in a 2mM equimolar mixture of Ca²⁺ and Mg²⁺ in the buffer as compared with the adhesion in the presence of 2.0mM Mg²⁺ alone.

The validity of the model developed is rendered in its documented consistency in the measurement of adhesion. The platelets of the population of volunteers used in the present study shows a normal distribution pattern of adhesion, with a narrow range of variability. This allowed for the investigation of the effects of platelet membrane modification by platelet activation, enzyme proteolysis, antibody binding and adhesive protein interaction.

B. EFFECTS OF PLATELET ACTIVATION

Platelet adhesion was studied with and without stimulation using two important agonists, ADP and thrombin.

1. ADP ACTIVATION

Introduction:

When exposed to this nucleotide, in the presence of fibrinogen, platelets undergo shape change and then aggregate. The latter protein is known to bind to the calcium-linked complex of membrane GPIIb/IIIa (Nachman and Leung, 1982), and stimulation leads to the exposure of these specific Ca^{2+} -dependent binding sites (Gogstad et al, 1982), that enhance this phenomenon. Radiolabelling shows this reaction to be minimal when examined in the resting state (Hawiger et al, 1980). However, this increased four- to five-fold with 4.5uM of the agonist, the binding can be saturated and is of high affinity. In parallel, ultra-structure showed transformation from a resting discoid shape to spherical forms, protrusion of several pseudopods and the lumens of the surface connected cannalicular system became distended. These characteristics have subsequently been confirmed in other studies (Marguerie et al, 1979; Bennett and Vilaire, 1979).

Aims:

To demonstrate the effects of activation by ADP on platelet adhesion to laminin. In view of the Ca^{2+} -dependence of fibrinogen binding after such stimulation, the presence of this divalent cation was also studied to clarify its role.

Methods:

The micro-titre wells were coated with 8ug/well of laminin and left at room temperature until they were needed.

Previously described conditions (Bennett and Vilaire 1979) were used in which plasma-free platelets were isolated through a Sepharose gel column, and involved:

- A: Blood was drawn into CPD-A1 and PRP prepared and labelled.
- B: 60mls of 2B Sepharose (Pharmaseal Laboratories, Glendale Calif.) were degassed under negative suction for 30 minutes and poured into a 50ml plastic syringe to a volume of 40mls. 100mls (2.5 times the column volume) of buffer A was used to equilibrate the column, which was sealed until required. 3mls of the platelet suspension were applied to the column.
- C: Platelets filtered through the gel with constant cycling of buffer A. In this way the heavier platelets were eluted ahead of the fibrinogen-rich plasma. 1ml fractions with the highest opacity (containing the highest platelet concentrations) were pooled and counted.

The preparation was then tested to ensure that it was free of fibrinogen-rich plasma, so that the binding sites could be activated without causing aggregation (Bennett and Vilaire, 1979). A negative aggregatory response to 10uM ADP stimulation was documented in a Payton dual channel aggregometer (Payton Associates Inc, Buffalo, M) using a total volume of 400ul, containing 300ul of $0,5 \times 10^8$ /ml platelets. A positive control sample of PRP aggregated normally, showing that there was no defective response to ADP.

Buffer A was added to the isolated platelets to achieve a final concentration of 5×10^8 /ml for each ADP concentration tested. The coated wells were aspirated free of excess laminin solution and then blocked with buffer A for 30 minutes. Preparations of platelets in buffer A alone and with 1mM calcium chloride were warmed to 37° in a water bath. The cells were then stimulated by adding 10uM ADP (Sigma Chemical Co., St. Louis, Mo) for 3 minutes. After

removal of excess buffer A, 50ul of each preparation was applied to the coated wells.

The adhesion assay was then performed in the standard way (described in Section A - Development of a micro-titre assay for measuring platelet-laminin interaction, Page 19). The results following on ADP stimulation with and without Ca^{2+} were expressed as a percentage of that of unstimulated and Ca^{2+} -free controls.

Results and discussion:

There was no increase in the adhesion of the ADP-stimulated platelets, with a mean of 101.67% (SE = 0.23), which decreased to a mean of 88% with a wider variation (SE = 16.74) in the presence of 1mM CaCl_2 , as shown in Table 1.

ADP(% of control)	ADP with Ca^{++} (% of control)
101.8	74.7
101.4	82.5
101.8	106.8
Mean: 101.6	88
Standard error: 0.23	16.74

Table 1. Adhesion following platelet activation with ADP
Activation of gel-filtered platelets with 10uM ADP without (first column) and with (second column) 1mM Ca^{2+} . Values are expressed as a percentage of unstimulated controls with the mean and Standard Error of three studies, each done in triplicate, using the same donor on different days

A similar unenhanced response to ADP is found in the binding of thrombospondin to platelets, increasing only to about 126% (Wolff et al, 1986). In the case of fibronectin binding, even an increase to 3 times the level of controls was considered as unenhanced (Plow and Ginsberg.1981).

These results are in sharp contrast to the effect of ADP on fibrinogen binding, which increased rapidly, 8-fold over the

binding of unstimulated platelets (Bennett and Vilaire, 1979).

However, caution should be exercised in interpretation of a negative response to ADP, as the critical period of maximal exposure of the binding site could have been missed. As seen in the case of fibrinogen, although specific binding increases at a constant rate for 30 minutes after activation (Marguerie et al, 1979), maximal enhancement has been shown to be transient (Mustard et al, 1978). When added after ADP stimulation, binding was less avid than when fibrinogen was added before stimulation. In the present study the platelets were added to the coated plates immediately after 3 minutes of ADP stimulation,

Conclusion:

Platelet adhesion to laminin is not induced by their prior stimulation with ADP. The presence of Ca^{2+} during this reaction inhibited this phenomenon, thereby duplicating and so confirming its effect on unstimulated washed platelets as found in the initial optimisation studies (Page 26).

2. THROMBIN ACTIVATION

Introduction:

This potent agonist binds to membrane GPIb with high affinity and concurrently activates GPIb-independent systems (Yamamoto et al, 1981). An important thrombin receptor system has recently been identified (Vu et al, 1991), which functions as a tethered intramolecular ligand, activated by the proteolytic action of thrombin which frees it to mediate platelet stimulation (Chen et al, 1994).

This leads to the enhancement of binding of macromolecular adhesive glycoproteins by GPIIb/IIIa (Coller, 1986). This is associated with a conformational change of the platelet (Zucker, 1980) represented diagrammatically below:

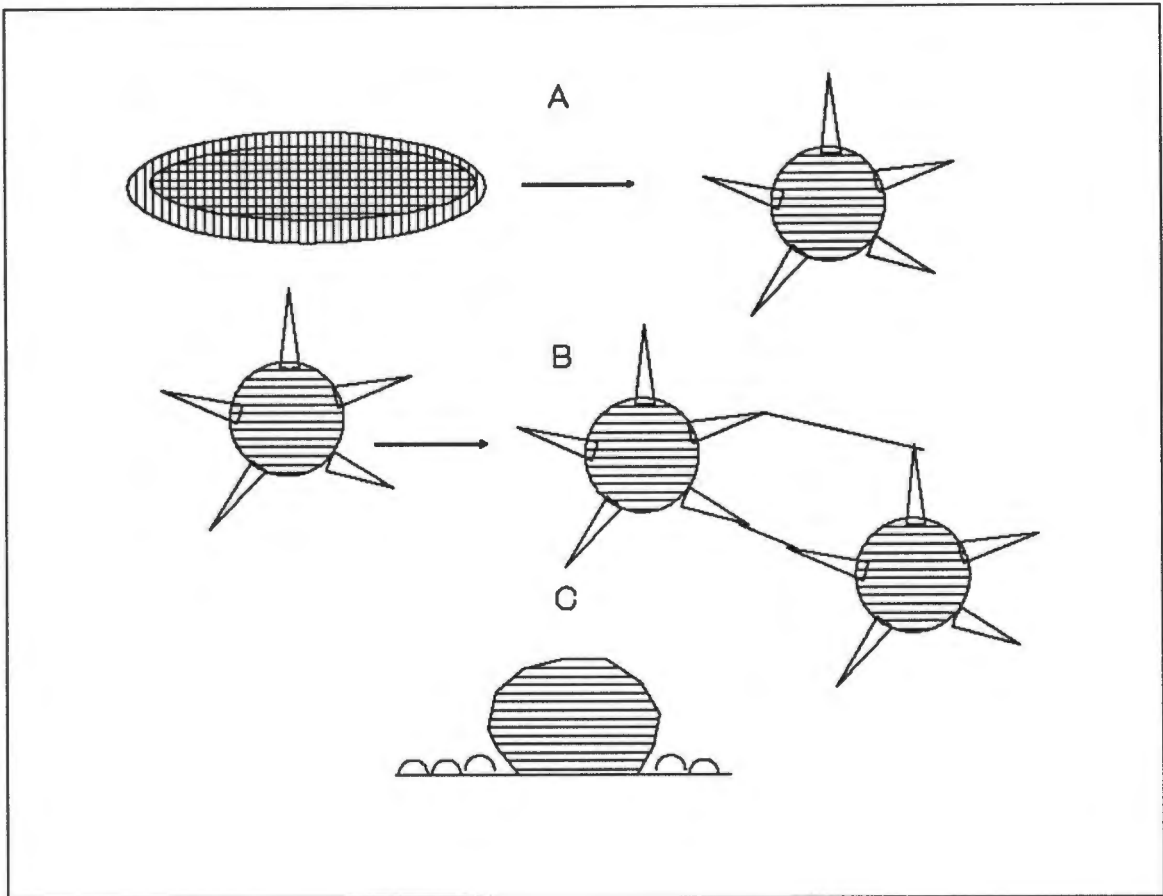

- (A) Platelets are activated, resulting in a shape change from discoid to round; the development of filopodia and pseudopodia (Reorganized actin and myosin)
- (B) Platelets aggregate when the tips of these extensions link to the GPIIb/IIIa of the membranes of adjacent platelets. The latter receptors, in their activated state, bind fibrin and to the adhesive glycoproteins of the subendothelial matrix (Tuszynski et al, 1985).
- (C) The aggregate contracts to form a plug.

Aims:

To demonstrate the effect of platelet activation by alpha-thrombin on the adhesion to laminin. The results would indicate whether receptors are exposed following this process

Methods:

Each micro-titre wells was coated with 8ug of laminin at room temperature until they were needed. Labelled platelets were prepared in the conventional way (See page 19), but using citrate wash buffer and buffer A containing EGTA (2mM) and PGE₁ (1ug/ml) in order to ensure that aggregation is prevented when thrombin was added. Aliquots for each thrombin concentration were prepared to achieve a final concentration of 5×10^8 .

The coated wells were then aspirated free of excess laminin solution and blocked with buffer A for 30 minutes.

Human alpha-thrombin, produced in Jamieson's laboratory according to the methods of Fenton et al (1977), was added to each platelet sample to achieve concentrations ranging from 0-2units/ml and incubated for 5 minutes. Hirudin (1000 units/mg protein, isolated from the leech (Pentapharm Ltd, Basel Switzerland) was then added to the preparation at equimolar concentrations to thrombin and the platelets were then washed once with EGTA-free citrate.

The excess blocking buffer was aspirated from the wells and the activated platelets were then added in triplicate. Adherence was then assayed in the standard way, that following on thrombin stimulation expressed as a percentage of that of controls.

Results and discussion:

No effect occurred at low thrombin concentrations, but adhesion decreased to a mean of 76.4% (SE = 5.02) at 2units/ml. This is shown in Fig.7

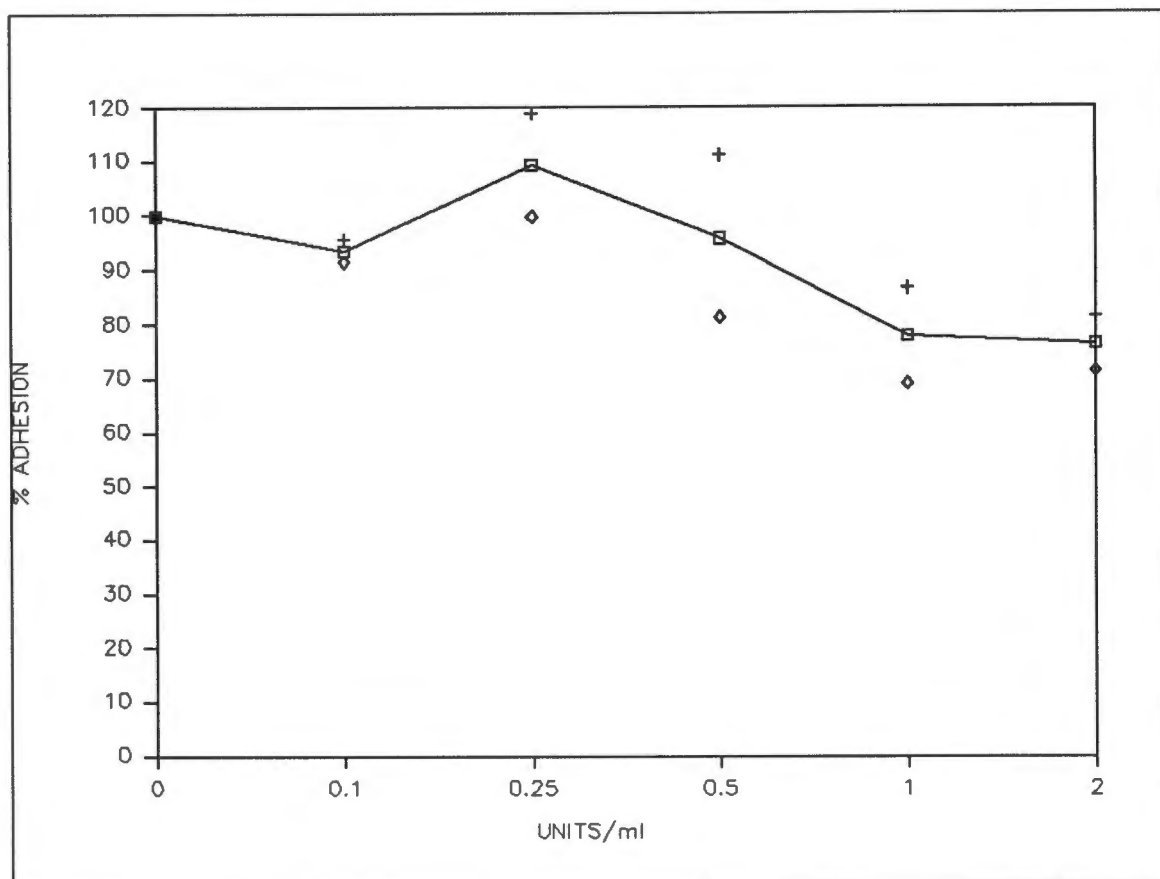

Fig.7. Adhesion following platelet activation with increasing concentrations of alpha-thrombin. Each point represents the mean plus/minus the Standard Error of three studies, each done in triplicate, using the same donor on different days.

The reason for the decreased adhesion seen after treatment with thrombin is unknown. Activation has been noted to induce conformational changes in glycoproteins GPIb, GPIIX and GPIIb/IIIa of the platelet membrane (Michelson and Barnard, 1987). A similar change of the receptor site for laminin could alter its binding capacity. Alternatively, thrombin-mediated proteolysis could modify the cognate receptor and so modulate its function. There also remains the possibility that thrombin had induced release of platelet constituents which could interfere with engagement with the ligand. The inhibitory effect of anti-fibrinogen antibodies as defined by aggregometry and phase contrast microscopy, was not associated with the release reaction as

measured by ^{14}C -serotonin labelling (Tollefsen and Majerus 1975). Release of fibrinogen contained within the alpha granules was unabated, became bound to the GPIIb/IIIa receptor and caused aggregation - this after all surrounding fibrinogen was inactivated by anti-fibrinogen F_{ab} . As will be demonstrated in later studies, increasing concentrations of fibrinogen caused a progressive and marked decrease in platelet adhesion to laminin. It is conceivable that, although aggregation was inhibited with the use of EGTA and PGE_1 , release of endogenous protein following on activation could interfere with laminin binding. However, the wash step after thrombin stimulation rules out such a mechanism in this study.

Conclusions:

The adhesion of platelets to laminin is not enhanced by their activation with thrombin.

SUMMARY OF PLATELET ACTIVATION STUDIES

Enhanced binding following on platelet activation has been demonstrated for fibrinogen (Bennett and Vilaire, 1979, Hawiger et al, 1980), fibronectin (Plow and Ginsberg, 1981), and von Willebrand factor (Fujimoto et al, 1982, Ruggeri et al, 1983). In the present study, ADP stimulation did not increase the adhesion of platelets to laminin. There was an inhibitory effect of thrombin stimulation on this event, which decreased to 76.4% in the presence of 2 units/ml of alpha-thrombin. This reduction was unexpected and its cause remains speculative as discussed above.

C - ROLE OF KNOWN PLATELET GLYCOPROTEINS

Three approaches were used to examine the role of known platelet glycoproteins. This phenomenon was defined firstly by adhesion following their experimental removal with proteolytic enzymes, secondly with the use of specific antibodies to established receptors of this class, and finally, in an experiment of nature with platelets obtained from two patients with deficiency of the GPIIb/IIIa receptor.

EFFECTS OF PLATELET MEMBRANE PROTEOLYSIS

Separate characterization was undertaken after exposure to trypsin, chymotrypsin, and the metalloprotease derived from the microorganism, *Serratia marcescens*

1. TRYPSIN

Introduction:

This powerful protease has been widely used to identify membrane components responsible for various platelet functions, where it removes GPIb and GPIIb, without affecting GPIIIa (Greenberg et al, 1979a).

GPIb (molecular weight of 140kDa) is the most sensitive component (Ganguly and Gould, 1979). Studies by Pepper and Jamieson (1969) and Okumura and Jamieson (1976), with cleavage of a 120kDa macroglycopeptide, found a residual tail with a molecular weight of 45kDa, which is the receptor for thrombin. Furthermore, treated platelets have decreased adherence to collagen (Cazenave et al, 1978), indicating that the receptor had been cleaved from the membrane.

Aims:

To demonstrate the effects of proteolysis with this enzyme on the adhesion of platelets to laminin, in order to explore firstly whether the mediators are trypsin-sensitive, and specifically the role of GPIb which is sensitive to such treatment.

Methods:

Micro-titre plates were coated with laminin and left at room temperature until needed.

Platelets were then prepared and labelled in the standard fashion, except where after the final wash, they were resuspended in buffer A without BSA. Aliquots were then treated with 0.1mg/ml of trypsin (Sigma Chemical Co. St Louis Mo) for varying periods ranging from 0 to 60 minutes, washed and resuspended in buffer A to attain a final concentration of 5×10^8 for each time point preparation.

The laminin-coated wells were aspirated free of excess coating solution and blocked with buffer A. After 30 minutes this was decanted and 50ul of platelets from the untreated control and the various incubation-time preparations added in triplicate. Adhesion was then assayed in the conventional way (Page 19). The ^{51}Cr content of the lysate of adherent platelets from the control and each time point preparation was expressed as a percentage of that in 50ul added to each set of wells. The adhesion of untreated platelets (not subjected to trypsin), was recorded as the 100% reference point.

Results and discussion:

As illustrated in Fig.8, adhesion decreased by 76% after 10 minutes of exposure of the platelets to the protease. Thereafter the drop was slower, with the adhesion at 60 minutes down to 7.27% (SE = 9.95). The protease effect was thus rapid and near complete within the first few minutes of exposure.

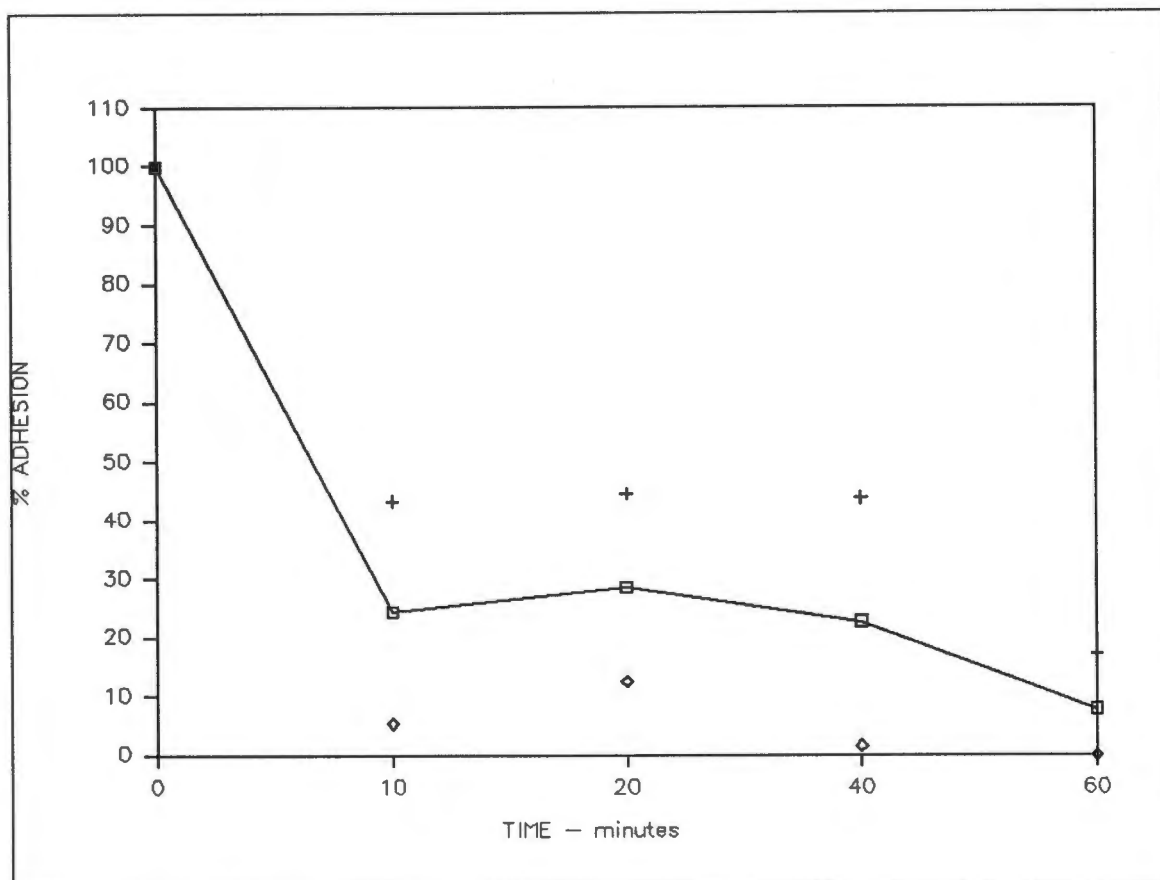

Fig.8: Adhesion following on treatment of platelets with trypsin 0.1mg/ml.

Platelet adhesion as a percentage of controls following on proteolysis for various periods of time. Each point represents the mean value of three studies, each done in triplicate, using same donor on different days, plus/minus the Standard Error.

Conclusion:

Laminin binding by platelets is mediated by a membrane component which is removed by trypsin proteolysis. Thus the sensitive portion of GPIb and GPIIb may play a role, but the resistant tail of GPIb and GPIIIa are excluded.

2. CHYMOTRYPSIN

Introduction:

Platelets treated with this enzyme have decreased adhesion to collagen coated surfaces (Santoro and Cunningham, 1979). They do not demonstrate amine storage release, and are thus not activated by the proteolysis (Podolsak, 1977; Greenberg et al, 1979b). Of note is that the PAS-staining material, presumably glycopeptides, recovered from the proteolysis is mainly the glycopeptide of GPI (Cazenave et al, 1979). Other studies have demonstrated a 45% removal of sialic acid (Okumura and Jamieson, 1976), as well as GPI, leaving only GPIV remaining (Greenberg et al, 1979a), with the result that they have a markedly reduced adhesion to collagen (Santoro and Cunningham, 1979). Confirmation was provided by Niewiarowski et al (1981), who also demonstrated a decreased aggregation response to ristocetin.

Platelets so treated respond poorly to thrombin and ADP, but aggregated when fibrinogen was added, without prior activation by agonists (Greenberg et al, 1979a, 1979b) (untreated platelets require prior activation). This was confirmed by Niewiarowski et al (1981) with the use of ^{125}I -Fibrinogen. The conclusion was that chymotrypsin proteolysis removed glycoproteins which shield the binding site in the resting state, which are not decreased, as proven with monoclonal antibodies to GPIIb/IIIa (Peerschke et al, 1984, Niewiarowski et al, 1985)

Tam et al (1980) studied the response of chymotrypsin-treated platelets to thrombin, showing there was neither a decrease in the rate or extent of binding, although there was a lag phase in the response. When hirudin was added during this phase, activation was abolished. This led to the conclusion that the thrombin binding site was resistant to the proteolytic effect of chymotrypsin, but separate from the active post-binding receptor processing point generating

the response signal. It is the latter site which is sensitive to the protease effect of chymotrypsin.

Aims:

To observe the membrane proteolytic effects of chymotrypsin on platelet adhesion to laminin. Specifically, to explore the roles of components resistant to such treatment, the thrombin receptor, GPIIb/IIIa (the fibrinogen receptor), and GPIV, the receptor for collagen (Tandon et al 1989b) and thrombospondin (Asch et al, 1987).

Methods:

The micro-titre plates and platelet suspension were prepared identically to that described for trypsin proteolysis (see methods above).

Aliquots of platelet were treated with 0.1mg/ml of chymotrypsin (Sigma Chemical Co. St Louis Mo) for 0 to 60 minutes. Each of the time point preparations were then washed and resuspended in buffer A.

The laminin-coated wells were aspirated free of excess laminin solution and blocked with buffer A. After 30 minutes this buffer was decanted and 50ul of platelets from the untreated control and the various incubation-time preparations were then added in triplicate. Adhesion was then assayed in the conventional way (Page 19). The ⁵¹Cr content of the lysate of adherent platelets from the control and each time point preparation was expressed as a percentage of that in 50ul added to each set of wells. The adhesion of untreated platelets (not subjected to chymotrypsin), was recorded as the 100% reference point.

Results and discussion:

Chymotrypsin treatment effected a sharp decrease in adhesion, to a mean of 69% (SE = 2.99) within 10 minutes and this was followed by a slower reduction, to reach 37% (SE = 4.14) at 60 minutes. These results are shown in Fig.9.

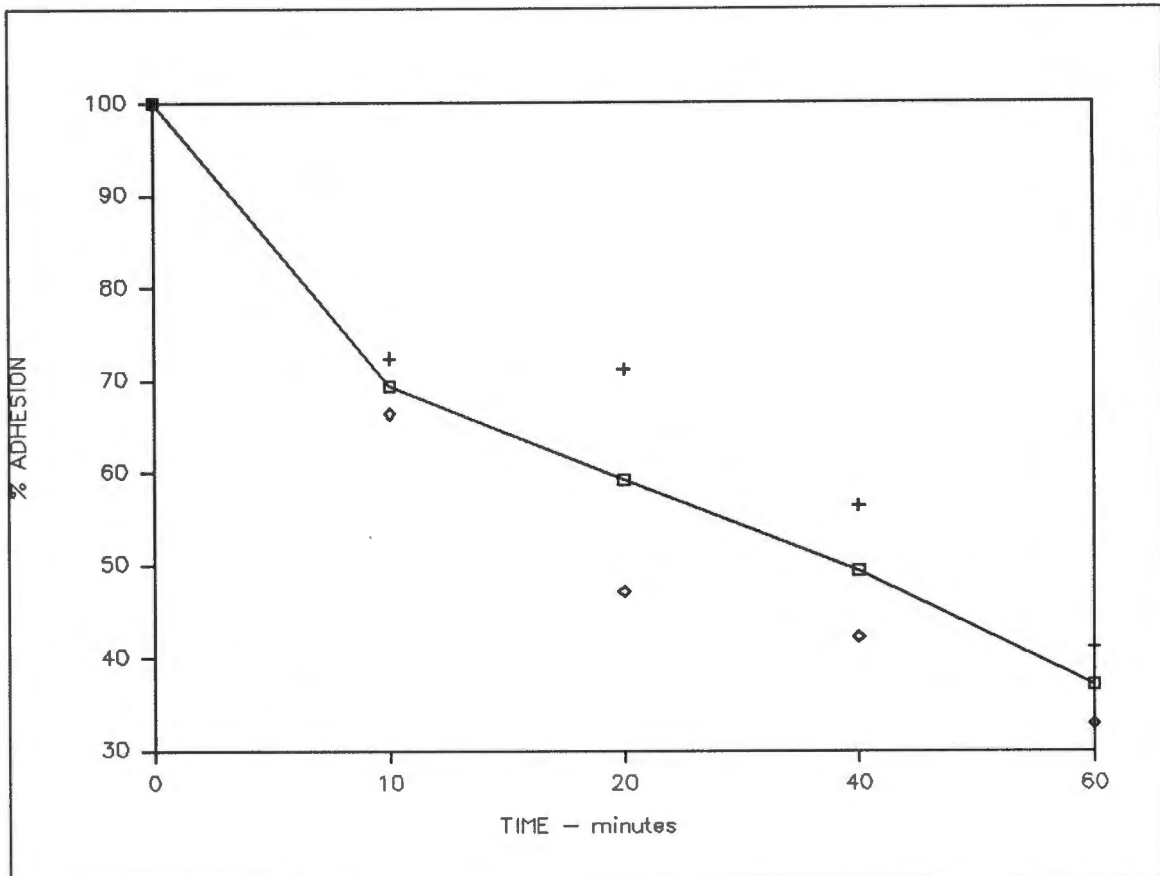

Fig.9: Effect of treatment of platelets with chymotrypsin 0.1mg/ml.

Platelet adhesion as a percentage of controls following on protease treatment for varying periods. Each point represents the mean value plus/minus the Standard Error of three studies, each done in triplicate, using the same donor on different days

The experiment was repeated with the concentration of the chymotrypsin increased to 0.2mg/ml. A similar pattern was observed, the adhesion at 10 minutes dropping to 57% (SE = 11.18) with a slower rate of fall thereafter, to reach values near to those obtained with 0.1mg/ml trypsin - 16% (SE = 6.74) at 60 minutes. These results are shown in Fig.10, together with those following chymotrypsin 0.1mg/ml and 0.1mg/ml trypsin treatment for comparison.

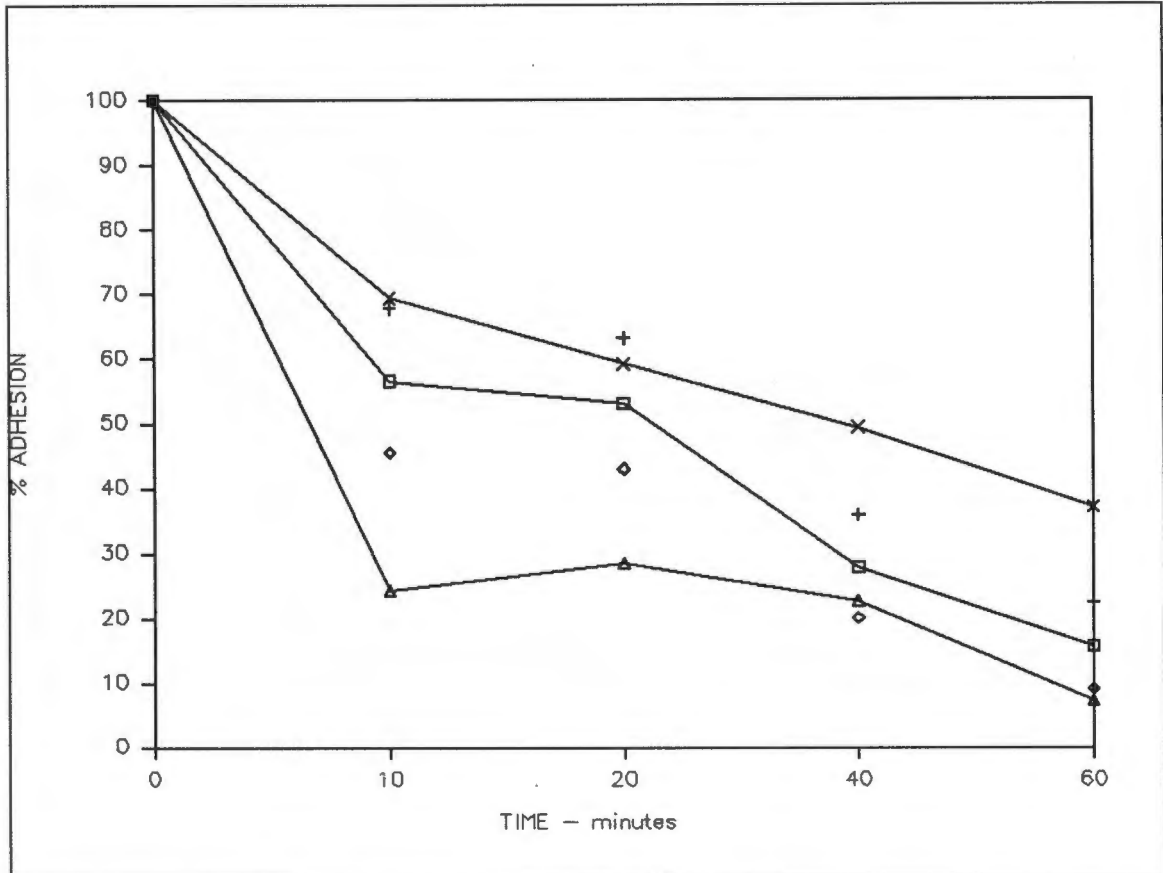

Fig.10. Effect of treatment of platelets with chymotrypsin 0.1mg/ml, chymotrypsin 0.2mg/ml and trypsin 0.1mg/ml. Graphs of platelet adhesion as a percentage of controls after treatment for varying periods with Top: Chymotrypsin 0.1mg/ml; Centre: Chymotrypsin 0.2mg/ml, means plus/minus Standard Error shown; Bottom: Trypsin 0.1mg/ml. Each point represents the mean of three studies using platelets from the same donor on different days.

Conclusion:

The platelet membrane component responsible for adhesion to laminin is sensitive to the protease effect of chymotrypsin, which is similar to, though less rapid than with trypsin. From these results, GPIV (Greenberg et al, 1979a), the fibrinogen receptor GPIIb/IIIa (Greenberg et al, 1979b; Niewiarowski et al, 1985; Peerschke et al 1984), and that for thrombin (Tam et al 1980), which remain intact on platelets treated this way have no role in the adhesion of platelets to laminin.

3. SERRATIA MARCESCENS METALLOPROTEASE

Introduction:

This enzyme has a selective effect on GPIb, which has a molecular weight of 185kDa (Cooper et al, 1982), which is cleaved, with the release of a 165kDa glycopeptide. Platelets thus treated became unresponsive to von Willebrand factor and ristocetin-mediated aggregation and were desensitized in their response to thrombin.

Aims:

To demonstrate the effect of the *Serratia marcescens*-derived metalloprotease on the adhesion of platelets to laminin through its selective effect on GPIb.

Methods:

The micro-titre plates and platelet suspensions were prepared identically to that for trypsin proteolysis (See above).

Aliquots of platelets were then treated with 0.2mg/ml of *Serratia* protease obtained from Jamieson's laboratory, for periods ranging from 0 to 60 minutes. Each of the preparations were then washed and resuspended in buffer A. The laminin-coated wells were aspirated free of excess laminin solution and blocked with buffer A. After 30 minutes this buffer was decanted and 50ul of platelets from the untreated control and the various incubation-time preparations were then added in triplicate. Adhesion was then assayed in the conventional way (Page 19). The ⁵¹Cr content of the lysate of adherent platelets from the control and each time point preparation was expressed as a percentage of that in 50ul added to each set of wells. The adhesion of untreated platelets (not subjected to the metalloprotease), was recorded as the 100% reference point.

Results and discussion:

Adhesion was not affected by the protease treatment, as seen in Table 2.

Treatment time (minutes)	10	20	40	60
Adhesion (% of control)	124.4	106.7	122.4	95.5
	110.1	109	120.2	105.6
	104.5	94.8	91.6	94.2
Mean:	113	103.5	111.4	98.43
Standard Error	10.26	7.62	17.18	6.24

Table 2. Adhesion of platelets treated with 0.2mg/ml of *Serratia marcescens* protease for varying periods of time
Each point represents the mean value of three studies, each done in triplicate, using the same donor on different days.

Conclusion:

The component of the platelet membrane responsible for the adhesion to laminin is not removed by the metalloprotease of *Serratia marcescens*. Because this enzyme selectively destroys the important adhesive glycoprotein, GPIb (Cooper et al, 1982), these results excludes its involvement in this process.

ANTIBODY STUDIES

Monospecific polyclonal immunoglobulins against glyco-calicin and GPIV were studied

1. ANTI-GLYCO-CALICIN

Introduction:

This antigen is a highly glycosylated fragment of glycoprotein Ib, rich in sialic acid and characterized by marked PAS staining. It is made up of a single polypeptide chain with a molecular weight of 150kDa and binds both thrombin and von Willebrand factor (Okumura and Jamieson (1976a, 1976b)).

Aim:

To determine the effect of antibodies to glyco-calicin on platelet adhesion to laminin. Thus by blocking the binding site on GPIb, unaffected adhesion would provide support for the findings using proteolysis of GPIb by the metalloprotease of *Serratia marcescens*, that it has no role.

Methods:

Micro-titre plates were coated with laminin at room temperature until needed. Platelets were then prepared and labelled as described (Page 19) and finally suspended in buffer A to attain a final concentration of 5×10^8 for each concentration.

Aliquots were incubated with increasing concentrations of Fab fragments of monospecific, polyclonal antibodies to glyco-calicin ranging from 0-20ug/well (0-400ug/ml) for 30 minutes at room temperature. The plates were decanted free of excess solution, buffer A added for 30 minutes and then removed, and platelets from each anti-glyco-calicin Fab concentration preparation added in triplicate. Adhesion was then assayed in the conventional way (Page 19). The

adherence at each antibody concentration was expressed as a percentage of the adherence of controls.

Results and discussion:

There was 85% adhesion (SE = 7.26) at concentrations of anti-glycocalicin as high as 400ug/ml (20ug/well). These results are shown in Table 3.

Concentration (ug/well)	2.5	5	10	20
Adhesion (% of control)	100.2	101.7	106.6	78.4
	102	112.4	94.9	92.6
	117.4	93.7	91.2	82.9
Mean:	106.53	102.6	97.57	84.63
Standard error:	9.45	9.38	8.04	7.26

Table 3. Adhesion of platelets in the presence of varying concentrations of polyclonal monospecific anti-glycocalicin Fab

Each point represents the mean value of three studies, each done in triplicate, using the same donor on different days.

Conclusion:

Since no inhibition occurred under these conditions, it can be assumed that GPIb is in no way implicated, confirming the results of the studies using the metalloprotease of *Serratia marcescens*.

2. ANTI-GLYCOPROTEIN IV

Introduction:

Physiologically GPIV is a single chain 88kDa glycoprotein. On isolation it inhibits the initial step in the adhesion of platelets to collagen (Tandon et al, 1989b) and also their interaction with thrombospondin (Asch et al, 1987). The

latter is an adhesion protein contained within platelets, required for their irreversible aggregation.

Aim:

To examine platelet adhesion after blocking the GPIV receptor with antibodies, in order to support the findings of the chymotrypsin proteolysis study (see above), that it has no integral role.

Methods:

The micro-titre plates and platelets were then prepared identically to the anti-glycocalicin study above.

Aliquots of platelets were incubated with concentrations of Fab fragments of monospecific, polyclonal antibodies to GPIV ranging from 0-400ug/ml (0-20ug/well) for 30 minutes at room temperature. The plates were decanted free of excess laminin solution, blocked with buffer A which was drained after 30 minutes and platelets from each anti-glycocalicin Fab concentration preparation added in triplicate. Adhesion was then assayed in the conventional way (Page 19). The adhesion at each concentration was expressed as a percentage of that in the absence of the antibodies.

Results and discussion:

Adhesion was 85% (SE = 18.58) at concentrations of anti-GPIV as high as 400ug/ml (20ug/well). These results are shown in Table 4.

Conclusion:

The failure of anti-GPIV antibodies to inhibit adhesion excludes a role for this receptor in the adhesion of platelets to laminin, confirming the conclusion of the chymotrypsin study

Concentration (ug/well)	2.5	5	10	20
Adhesion (% of control)	94.3	86.5	74.1	63.2
	103.4	97.1	90.7	97.2
	97.1	91.8	102.5	93.2
Mean:	98.27	91.8	89.1	84.53
Standard error:	4.66	5.3	14.27	18.58

Table 4. Adhesion of platelets in the presence of varying concentrations of polyclonal monospecific anti-GPIV Fab
Each point represents the mean value of three studies, each done in triplicate, using the same donor on different days.

GLANZMANN'S THROMBASTHENIA

Introduction:

This autosomal recessive bleeding disorder is characterized by a prolonged bleeding time and absent or delayed clot retraction (Solum 1985). There is no aggregatory response to ADP, collagen, thrombin and adrenalin due to the absence of GPIIb/IIIa from their platelet membranes, including another GPIIIa component - the PL^{A1} alloantigen. This is in contrast to other aspects of the platelet membrane structure and function which are intact, such as the von Willebrand factor systems. Thus they adhere normally to collagen fibres (Caen et al, 1966) and to exposed subendothelial tissue in flowing blood (Tschopp et al, 1974).

Aim:

To examine the adhesion of platelets from individuals with this disorder, which would provide conclusive information about the role of the missing receptor and verify the observation of the study using chymotrypsin proteolysis (see above) which negates such a role.

Methods:

Micro-titre plates were coated with laminin and blocked with buffer A until needed. Platelets from two blood samples as well as from a normal control were prepared and labelled in the conventional fashion (Page 19). 5×10^8 /ml of each sample were added to the coated wells, and the adhesion assayed. That of the Glanzmann's platelets was expressed as a percentage of the normal control.

Results and discussion:

As seen from Fig.11, the platelets from both patients adhered normally, with values of 95% and 90% of the control.

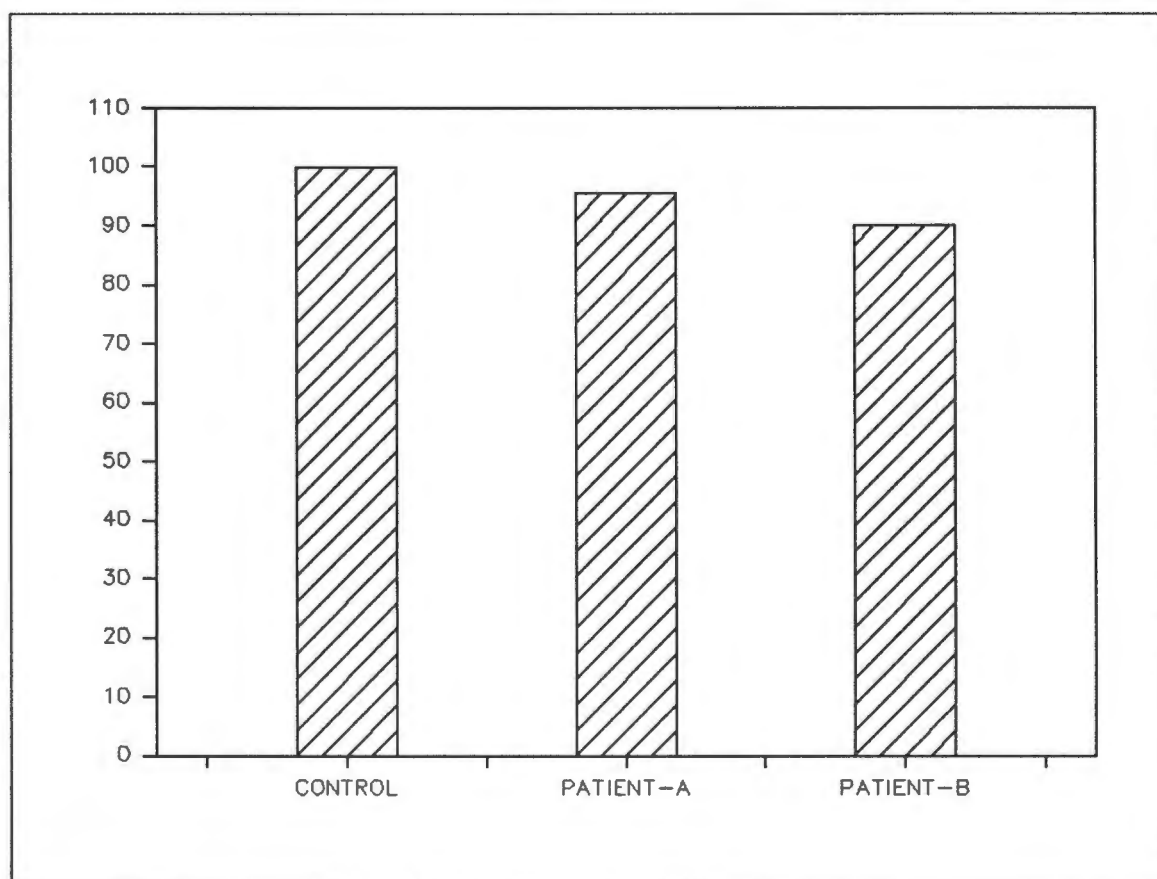
**Fig.11: Glanzmann's Thrombasthenia**

Adhesion as a percentage of controls of the platelets of two patients with Glanzmann's Thrombasthenia, who have a congenital deficiency of the GPIIb/IIIa platelet membrane receptor. The values are the means of triplicate readings.

Conclusion:

The glycoprotein GPIIb/IIIa is conclusively ruled out as being the receptor for laminin on the platelet membrane. The findings using chymotrypsin proteolysis are confirmed.

SUMMARY OF MEMBRANE GLYCOPROTEIN STUDIES

Different kinetics govern the enzymatic cleavage of the laminin receptor from the membrane, which can be exploited in defining the mechanism of adhesion. A rapid proteolytic effect is found with trypsin, whereas with chymotrypsin this is slower and requires a higher concentration to achieve an equivalent effect.

GPIV is not removed by chymotrypsin (Greenberg et al, 1979a), thus the decreased adhesion after treatment excludes it as playing a role. The unaffected adhesion in the presence of antibodies to GPIV supports this conclusion.

Similarly the receptors of GPIb are not involved. Thrombin binding sites are not removed by trypsin (Pepper and Jamieson, 1969; Okumura and Jamieson, 1976) or chymotrypsin (Tam et al, 1980), and thus the decreased adhesion excludes this site. Also the *Serratia marcescens* metalloprotease removes the von Willebrand factor receptor of GPIb (Cooper et al, 1982), but does not affect adhesion. Furthermore, antibodies to glyocalicin did not inhibit adhesion.

GPIIIa remains intact after trypsin proteolysis (Greenberg et al 1979a), and thus the decreased adhesion excludes its involvement. The GPIIb/IIIa complex, the fibrinogen receptor, remains intact on trypsin and chymotrypsin treated platelets (Peerschke et al 1984; Niewiarowski et al, 1981, Niewiarowski et al, 1985), and is similarly excluded. Finally and conclusively, complex is excluded by the finding that platelets of individuals with Glanzmann's Thrombasthenia, who do not have this receptor on their membranes, adhere normally to laminin.

D - ROLE OF ADHESIVE PROTEINS

Having defined the role of the key membrane components in the adhesion to laminin, this binding process was examined in relation to that for other plasma proteins. Fibrinogen, bound by GPIIb/IIIa, von Willebrand factor, bound by GPIb, and the peptide, RGDS, a structural component of many adhesive proteins which is recognised by a wide range of membrane receptors, were useful in this regard.

1. FIBRINOGEN

Introduction:

The receptor for this protein is known to be the Ca^{2+} -dependent GPIIb/IIIa complex (Bennett and Vilaire, 1979). Extracellular binding is specific and saturable on ADP-stimulated platelets (Brinkhous et al, 1965), as confirmed by the abolition of aggregation with the use of anti-fibrinogen F_{ab} (Tollefsen and Majerus, 1975). No intra-platelet fibrinogen is released with ADP-induced aggregation, in contrast to the release with thrombin activation (Holmsen et al, 1969), allowing aggregation to proceed unabated in the presence of anti-fibrinogen antibodies.

Binding of fibrinogen to the platelet in its resting state is non-specific and unsaturable up to levels greater than 10mg/ml, in contrast to that with ADP stimulation, which is specific and saturable at 0.2mg/ml (Peerschke et al 1980).

Aim:

To study the adhesion of platelets to laminin in the presence of fibrinogen.

Methods:

The micro-titre plates and platelets were prepared in the conventional way (Page 18 and 19).

Aliquots of platelets were incubated with increasing concentrations of fibrinogen up to 2mg/ml, for 30 minutes at room temperature. The coated micro-wells were blocked as described and platelets from each concentration preparation added in triplicate. Adhesion was then assayed (Page 19). The adherence at each fibrinogen concentration was expressed as a percentage of controls.

Results and discussion:

At low concentrations there was a rapid peak in adhesion, with a mean of 164% (SE = 23.9) at 0.25 mg/ml, dropping rapidly to 46% (SE = 19.55) at 1.0 mg/ml and at physiologic plasma levels of fibrinogen, 2.0 mg/ml, adhesion was totally inhibited. These results are shown in Fig.12.

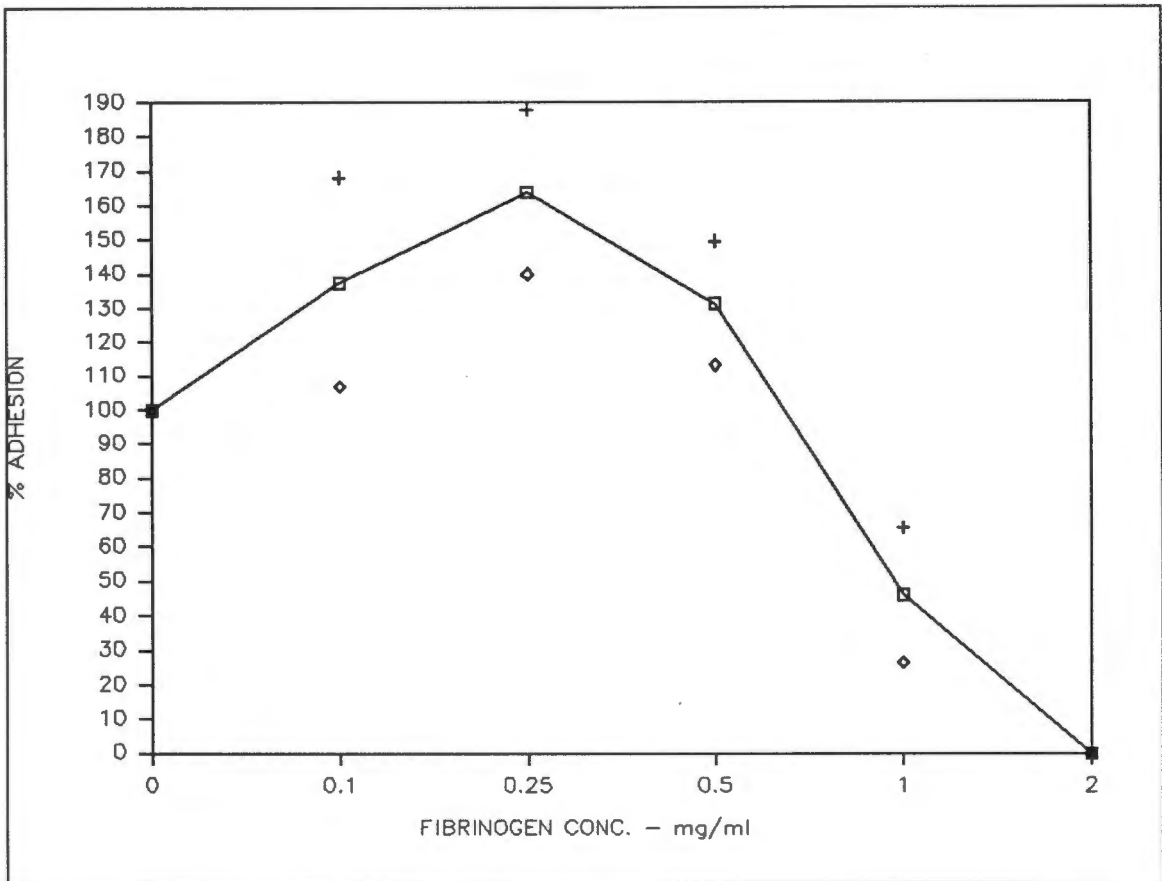

Fig.12: Interaction with fibrinogen

Effect of incubation of platelet suspensions with increasing concentrations of fibrinogen (mg/ml) on the adhesion of platelets, expressed as a percentage of controls. Each point represents the mean value of three studies, each done in triplicate, using the same donor on different days, plus/minus the Standard Error

It would thus appear that non-specific occupation of the GPIIb/IIIa receptor by fibrinogen altered membrane binding. Thus lower concentrations appeared to expose the site and enhances adhesion, but as this rises into the physiologic range blocking occurs. Parallels exist in the binding of thrombin-stimulated platelets to thrombospondin (Wolff et al, 1986) and fibronectin binding to platelets (Plow et al 1985) in the presence of this protein. The latter authors considered the following as mechanisms for this phenomenon:

1. Fibrinogen may spatially interfere with fibronectin association.

2. Down-regulation of the binding site for fibronectin.
3. Higher affinity for the site which is responsible for fibronectin binding.
4. Interaction with fibronectin which results in interference.

Taken in context, it is postulated that inhibition of platelet interaction with adhesive proteins by fibrinogen may play a role in preventing platelet adhesion in the disease-free state. Such a role was also suggested for platelets in the activated state (Pietu et al 1984). ADP- or thrombin-activated binding of von Willebrand factor was inhibited by 80% in the presence of physiological concentrations of fibrinogen. This was confirmed in a later study which also demonstrated normal binding of radio-labelled von Willebrand factor to activated platelets in the plasma of patients with congenital afibrinogenaemia and in plasma heat-treated to inactivate all the plasma fibrinogen (Schullek et al 1984). These plasmas became inhibitory for von Willebrand factor binding when fibrinogen was added at a concentration above 1mg/ml.

Conclusions:

The following chart summarizes the findings and likely mechanisms:

A	B	C
<u>CONCENTRATION</u>	<u>EFFECT</u>	<u>ADHESION</u>
Low	Site exposed	Increased
High	Site blocked	Decreased

2. VON WILLEBRAND FACTOR

Introduction:

As reviewed by Ruggeri and Zimmerman (1985), this is a multimeric glycoprotein of endothelial origin, and circulates as a noncovalent complex with the procoagulant protein, Factor VIII, where it contributes to about 95% of the mass of the complex.

Physiologically, in coagulation it serves to protect Factor VIII from degradation. Congenitally decreased levels or abnormal forms are found in von Willebrand's disease where it contributes to the haemostatic defect by allowing rapid degradation of Factor VIII. A second physiological consequence of the quantitative and qualitative defect in the molecule is the abnormal adhesion of platelets at high shear rates within the circulation. Under these conditions von Willebrand factor bound to GPIb on the membrane, attaches to exposed subendothelial tissues, thus allowing the platelets to adhere. In its absence, this function is lost.

GPIb binding of von Willebrand factor is induced by the antibiotic ristocetin (Kao et al 1979). This cannot occur in patients with the Bernard Soulier syndrome with a congenital absence of GPIb (Jenkins et al, 1976), as also found with the use of monoclonal antibodies (Coller et al, 1983).

Binding of von Willebrand factor to platelets activated by agonists is mediated by a different mechanism. Ruggeri et al (1983) used platelets from normals, patients with the Bernard Soulier syndrome (absent GPIb) and Glanzmann's Thrombasthenia (absent GPIIb/IIIa) to demonstrate that GPIIb/IIIa is the receptor for von Willebrand factor on the stimulated platelet, and that this binding was totally independent of the ristocetin-induced GPIb mechanism.

Aim:

To determine the effect of the presence of von Willebrand factor on the adhesion of platelets to laminin

Methods:

The micro-titre plates and platelets were prepared in the conventional way (Page 18 and 19)

Aliquots of platelets were incubated with increasing concentrations of purified von Willebrand factor, up to 2 units/ml for 30 minutes at 37^o. The plates were blocked, the excess decanted as described (Page 19) and platelets from each concentration preparation added in triplicate. Adhesion was then assayed in the standard way. The adherence at each von Willebrand factor concentration was expressed as a percentage of controls.

Results and discussion:

At physiological levels of 1 unit/ml, there was 38% inhibition, increasing to 66% at 2 units/ml, as shown in Fig.13.

This data is most consistent with interference of nonspecifically bound von Willebrand factor with the membrane site for laminin binding. As previously reported (Ruggeri et al 1983), non-specific binding of Radio-labelled von Willebrand factor in the resting state increase linearly as the concentration of the von Willebrand factor increases, to a level 10-35% of that bound to stimulated platelets. Excess 'cold' von Willebrand factor was able to displace the specifically bound labelled von Willebrand factor, which decreased down to 30-50% of the maximal binding.

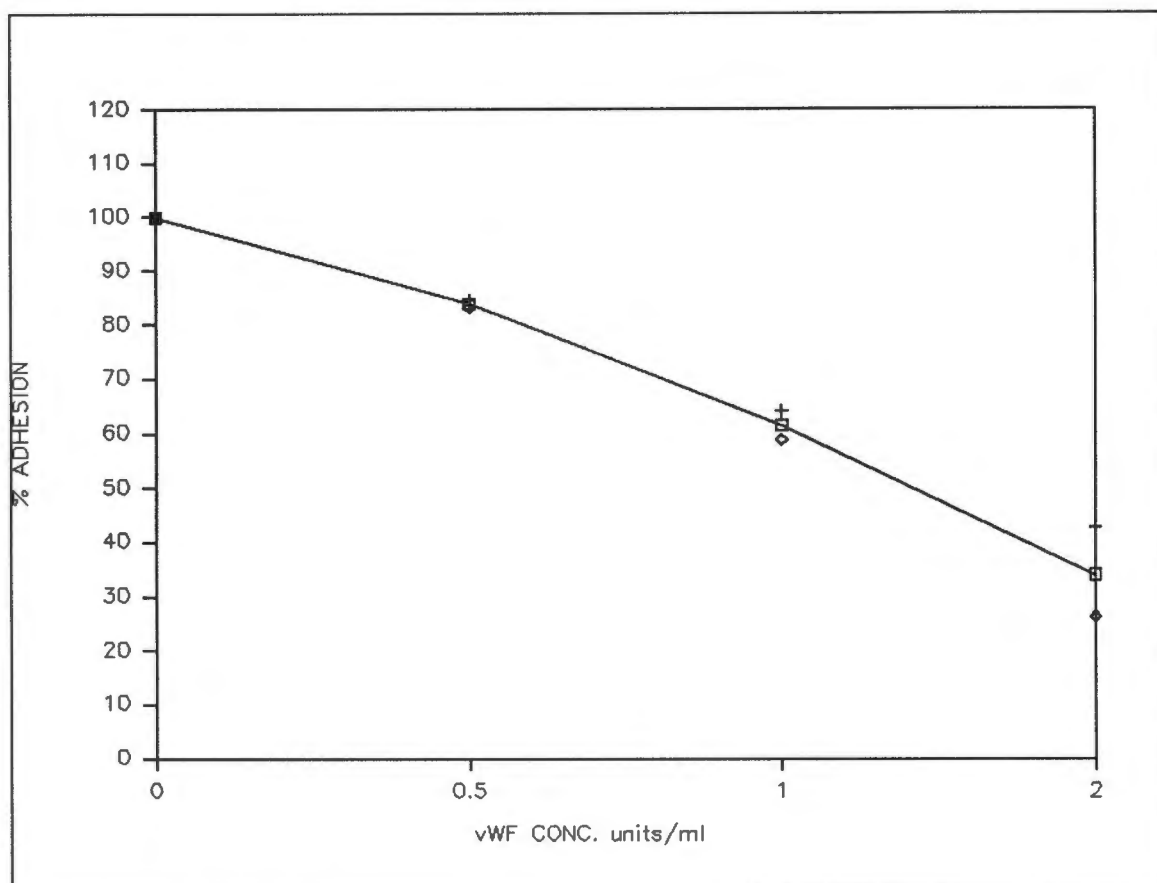

Fig.13: Effect of von Willebrand Factor

Effect of incubation of platelets with increasing concentrations of von Willebrand factor on adhesion, expressed as a percentage of controls. Each point represents the mean value of two studies, each done in triplicate, using the same donor on different days, plus/minus the Standard Error (SE).

Conclusion:

von Willebrand factor inhibits the adhesion of platelets to laminin.

3 THE ADHESION PEPTIDE - RGDS

Introduction:

A wide range of receptors with significant identity of their amino acid sequences as deduced from cDNA sequences, have recognition specificity for a critical amino acid sequence: arginine (R) - glycine (G) - aspartic acid (D), and

sometimes - serine (S). The adhesion proteins fibrinogen, fibronectin, von Willebrand Factor and vitronectin have all been shown to contain this sequence.

RGD(S) recognition in the binding of ligands has been demonstrated for all members of the integrin superfamily. Members of the cytoadhesin family, particularly GPIIb/IIIa, exhibits high affinity, critical for fibrinogen binding (Pytela et al, 1986). The leu-cam family recognizes a region of the complement protein C3 which contains the RGD amino acid sequence (Wright et al, 1987). The VLA family also has the recognition specificity for a wide range of adhesive proteins, but their affinity is less than that of the cytoadhesins (Ginsberg et al, 1987).

Although previous studies have shown unaffected adhesion of platelets to laminin in the presence of RGDS up to a concentration of 1mM (Ill et al, 1984, Sonnenberg et al, 1988), this is such an important peptide in cell binding of adhesive proteins, that it was still considered important to confirm this in the present model.

Aim:

To study the interaction of RGDS with platelet adhesion to laminin. This would provide information about the nature of the recognition site of the responsible platelet membrane component.

Methods:

The micro-titre plates and platelets were prepared in the conventional way (Page 18 and 19).

Aliquots of platelets were incubated with increasing concentrations of RGDS (Peninsula Laboratories Inc. Belmont, CA) up to 1mM/ml for 30 minutes at room temperature. The plates were blocked, the excess decanted as described (Page 19) and platelets from each RGDS concentration preparation were then added in triplicate. Adhesion was then assayed in

the standard way. The adherence at each RGDS concentration was expressed as a percentage of controls.

Results and discussion:

There was an initial drop in adhesion to a mean of 73% (SE = 9.02) at a concentration of 0.1mM RGDS, with a slower rate of fall thereafter, to a level of 50% at 1mM. This is shown in Table 5.

Concentration (mmol)	0.1	0.5	1.0
Adhesion % of control	76.5	69.6	60.3
	79.2	65.6	49.6
	62.4	46.3	39.5
Mean:	72.7	60.6	49.8
Standard error:	9.02	12.57	10.4

Table 5. Adhesion in the presence of varying concentrations (mM/ml) of the RGDS peptide
Means of triplicate readings of three studies, using the same donor on different days.

Thus no specific inhibition of adhesion could be demonstrated. However, the constant fall observed, without reaching a plateau, suggests some inhibition of adhesion by RGDS at very high concentrations. However, as demonstrated by Ill et al (1984), who found a similar gradual drop in adhesion, the rate of fall was no different from that found with an irrelevant peptide. This suggests a non-specific effect of RGDS.

Conclusion:

The molecular structure responsible for the adhesion to laminin does not specifically recognise the peptide RGDS, contrary to the findings in a wide range of adhesive

proteins bound by all members of the integrins, particularly the cytoadhesins. It is thus similar to that for thrombospondin (Asch et al 1987), even though the RGD sequence has been identified in the cloned thrombospondin message (Lawler and Hynes, 1989). Laminin may similarly be found to contain this sequence, but at a site separate from that responsible for ligand binding by the platelet membrane.

SUMMARY OF ROLE OF ADHESIVE PROTEINS.

It appears that fibrinogen and von Willebrand factor interfere with laminin membrane binding on platelets. What was not excluded at this stage was artifactual adsorption of these proteins onto the laminin surface, blocking interaction with the membrane recognition site. This possibility was examined by adhesion experiments in which the laminin coated micro-wells were pre-incubated with von Willebrand factor up to twice the physiological concentration (2 units/ml), and fibrinogen up to 2 mg/ml, followed by washing of the wells with buffer A. Washed and labelled platelets were then added to the wells and adhesion assayed in the standard fashion. This produced no inhibition of adhesion of platelets, as seen in Fig.14, which rules out such a possibility.

The most likely explanation is that this is a non-specific effect (Dr. Leon W Hoyer: personal communication). This was also considered as the mechanism of the inhibitory effect of fibrinogen on thrombospondin binding to thrombin-stimulated platelets (Wolff et al 1986).

These facts, derived experimentally, extrapolate to physiologic regulation. Marked inhibition of binding of von Willebrand factor to ADP- or thrombin-stimulated platelets by physiological concentrations of fibrinogen was found (Pietu et al 1984). The latter authors considered the

likelihood that this interaction may play a role in maintaining blood platelets in the resting state within the circulation, preventing adhesion to vessel walls.

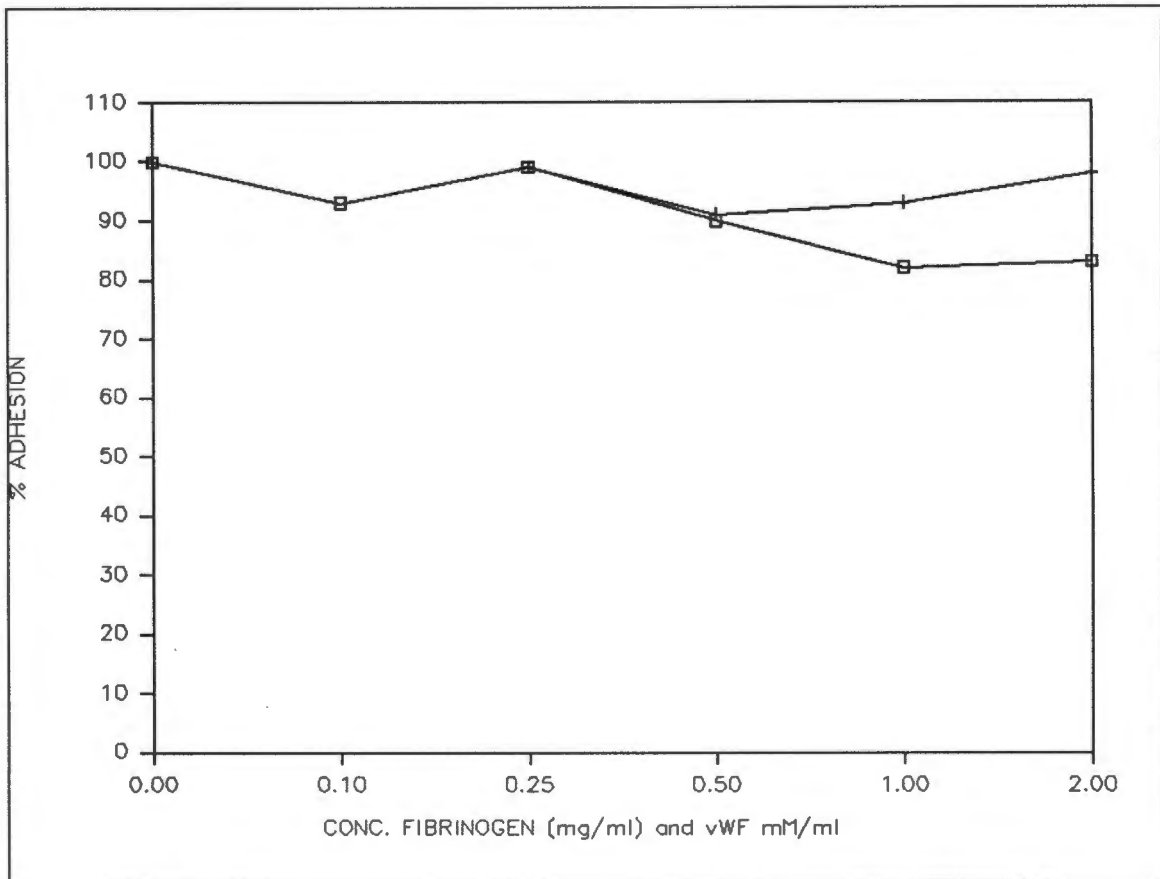

Fig.14: Effect of pre-incubation of the laminin-coated wells with fibrinogen and von Willebrand Factor
 The wells were pre-incubated with increasing concentrations of fibrinogen (mg/ml) (bottom) and von Willebrand factor (units/ml) (top) and washed before determining platelet adhesion as a percentage of controls. Values are the means of triplicate readings.

The platelet membrane component responsible for the adhesion to laminin does not appear to recognise the important RGDS peptide sequence. However, the model conditions could allow for underestimation of its role, as demonstrated in its recognition in the C3 complement molecule by leu-cam of neutrophils, only becoming evident when tested as part of a larger peptide (Wright et al 1987). This was not tested in the present study.

III ISOLATION OF THE PLATELET LAMININ RECEPTOR

As there was no precedent for this work, the initial development was based on methods used to isolate laminin receptors from the membranes of human breast carcinoma cells (Barsky et al, 1984a).

A. PREPARATION OF SOLUBILIZED PLATELET MEMBRANES:

250 mls of platelet rich plasma were prepared by centrifugation of whole blood drawn in CPD-A1. 50ug of PGE₁, 2mM benzamidine, 1ug leupeptin and 5mM EGTA were added to prevent aggregation.

After two washes with citrate buffer containing 0.35% BSA, pH 6.5, and one with citrate buffer pH 6.5 without albumin, they were resuspended in 5ml of 50mM tris buffer containing 5mM EGTA, 2mM phenylmethylsulphonyl fluoride and 50ug/ml leupeptin, at a platelet concentration of 2×10^9 /ml.

Following sonification at 4° (Bronson Sonifer, setting 7) using 5x 20-second pulses at 15-second intervals, providing a crude membrane preparation, the cell debris and unbroken platelets were removed by centrifugation at 10,000xg for 10 minutes at 4°.

The membrane fraction was recovered by centrifugation at 100,000xg for 90 minutes at 4° and dissolved in 2mls buffer A (without albumin), pH 7.4, containing 0.1% Triton X100 and 100ug leupeptin with rotation for 2 hours at 4°. The insoluble material was removed by centrifugation at 100,000xg for 30 minutes at 4°.

B. PREPARATION OF THE LAMININ-SEPHAROSE COLUMN:

10mg of laminin (Collaborative Research, MA) was concentrated by centrifugation at 800rpm for 10 minutes using a PM-30 Amicon Centricon ultrafiltration apparatus. The volume was made up to 100ul and added to 1ml of a 0.1M Na-bicarbonate, 0.5M NaCl buffer at pH 8.3.

333mg of CNBr-activated Sepharose 4B (Sigma Chemical MO) was added to 50ml 1mM HCl on ice, filtered and washed several times. The gel was then transferred to a small column (Econo-Column, Biorad).

The laminin in bicarbonate-saline buffer was added to the gel, and rotated for 3 hours at room temperature. The laminin-gel was centrifuged at 2,000 rpm for 5 minutes and then blocked with 1ml of 1M ethanolamine, pH 8 for 2 hours at room temperature. The coupled gel was then washed twice with the bicarbonate-saline buffer and then with buffer A (without albumin).

C. BINDING OF SOLUBILIZED PLATELET MEMBRANES TO COLUMN:

This preparation was washed twice with buffer A (without albumin) pH 7.4, and resuspended in a final volume of 40ul, which was added to the laminin-Sepharose column.

After 18 hours of cycling at 4° at a flow rate of 20ml/hr, the column was washed several times with the same suspension buffer. Sequential elution was then carried out with a series of buffers, 3 column volumes each: Buffer A, buffer A with 0.1% Triton X100, buffer A with 0.1% Triton X100 and 1M NaCl, buffer A with 0.1% Triton X100 and 5mM EGTA and finally with 0.2M glycine-HCl with 0.1% Triton X100 at pH 2.85. Each fraction was collected into tubes containing 75 ul Tris (1M/l) so as to raise the pH to 7.6. 1ml of each fraction was then concentrated by ultrafiltration (Amicon

Centricon, PM30 apparatus) and centrifugation at 800rpm for 10 minutes.

D. ELECTROPHORESIS OF THE ELUATE:

This was carried out on samples from each of the fractions of the sequential elution, solubilized in 1% sodium dodecylsulphate (SDS), in their non-reduced form in a 7% SDS-polyacrylamide gel, using tris.glycine buffer.

Solubilized samples of the final eluate were similarly processed in both the nonreduced form and after exposure to 2.5% 2-mercaptoethanol, together with a control sample of human serum albumin which has a similar molecular weight, and high molecular weight standards (2000,000 - Myosin: rabbit skeletal muscle; 116,250 - Beta-galactosidase: E Coli; 97,400 - Phosphorylase B: rabbit muscle; 66,200 - Bovine serum albumin; 45,000 - Ovalbumin: hen egg white; 31,000 - Carbonic anhydrase: bovine; BioRad, Richmond Cal) on the same gel.

Proteins on the gel were fixed with 12% trichloroacetic acid, silver stained (Biorad) and the molecular weights determined by plotting against the curve generated from the standards.

RESULTS:

The sequential eluate revealed increasing purity of a single band of about 53kDa, becoming very dense in the final fraction with 0.2 mmol glycine-HCl containing 0.1% triton X100 at pH 2.85, seen in Plate 5.

Plate 5. Membrane components from the sequential elution from the laminin-affinity column.

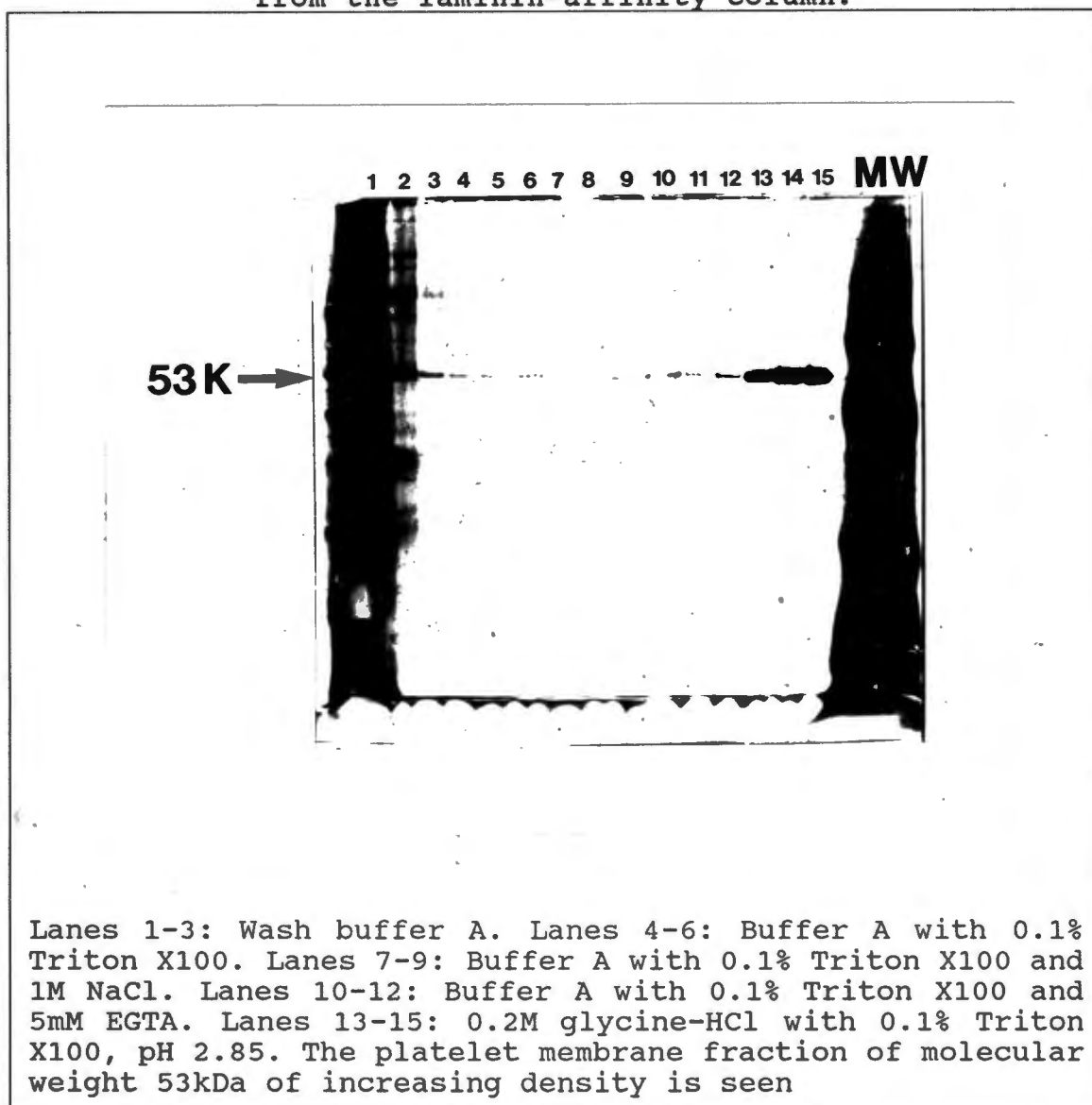

The elution pattern was identical to that obtained during the isolation of the well characterized laminin receptor isolated from the membranes of human breast carcinoma cells (Liotta: personal communication).

The final eluate revealed a single major band indicating about 95% purity, although some minor components were detectable, particularly in the reduced gel, as seen in Plate 6.

Plate 6. Platelet membrane laminin receptor.

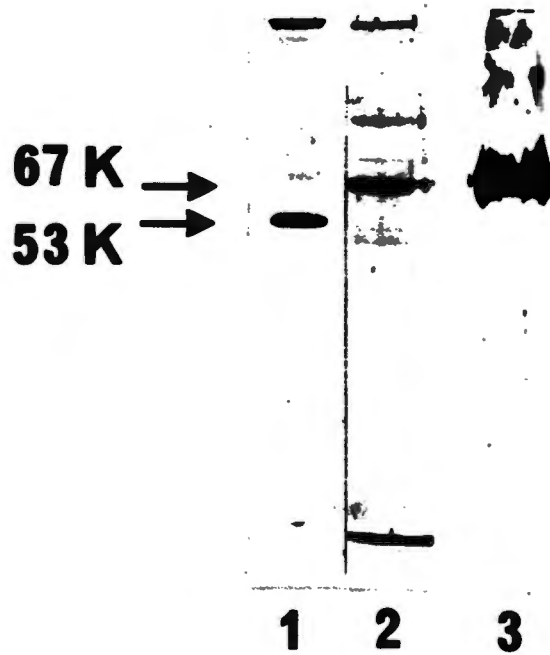

7% SDS gel of the laminin receptor eluted with glycine HCL, 0.1% Triton X100, pH 2.85 buffer, in the non-reduced (MW 53kD) and reduced state (67kDa), distinct from the human albumin control.

The molecular weight of this component, 67kDa in the reduced state and 53kDa in the unreduced state, was identical with that previously reported for the laminin receptor of human carcinoma and murine fibrosarcoma cells (Terranova et al, 1983; Malinoff and Wicha, 1983).

E. BLOT IDENTIFICATION:

Nitrocellulose membrane (Bio-Rad) was cut to fit a petri dish, soaked with tris buffered saline, pH 7.5. and then dried for 5 minutes on filter paper.

A concentrated sample (5ul) of the final eluate was applied to two of the quadrants marked on the membrane, with control samples of human albumin on the other two. Excess binding sites were blocked with Tween 20 (0.3%) in phosphate buffered saline (PBS), containing 2% BSA for 45 minutes using gentle agitation on a shaker platform. A 1:1,000 dilution of laminin in PBS containing 2% BSA was added to the preparation (aspirated free of blocking buffer immediately prior to use), and incubated overnight at 4°.

After several washes with PBS-Tween 20 containing 0.1% BSA, the buffer was aspirated off and a 1:1,000 dilution of rabbit anti-laminin antibody (Collaborative Research, Bedford, MA) in PBS containing 0.1% BSA added and incubated for 3 hours at 4°.

The paper was then washed several times with PBS-Tween 20 containing 0.1% BSA. After the final wash buffer was aspirated off, peroxidase-conjugated goat anti-rabbit IgG (Bio-Rad Immun-Blot GAR-HRP) was added and incubated for 1 hour at room temperature with gentle agitation. This was followed by several washings with PBS-Tween-BSA wash buffer, the final wash with tris buffered saline, pH 7.5. The proteins were identified using freshly prepared 4-chloro-1-naphthol and hydrogen peroxide colour developing reagent (BioRad).

RESULTS:

Blot identification of the concentrated sample of the final eluate on nitrocellulose paper demonstrated adherence of laminin to the eluted protein, with a negative reaction to human albumin which has a similar molecular weight, as seen in Plate 7.

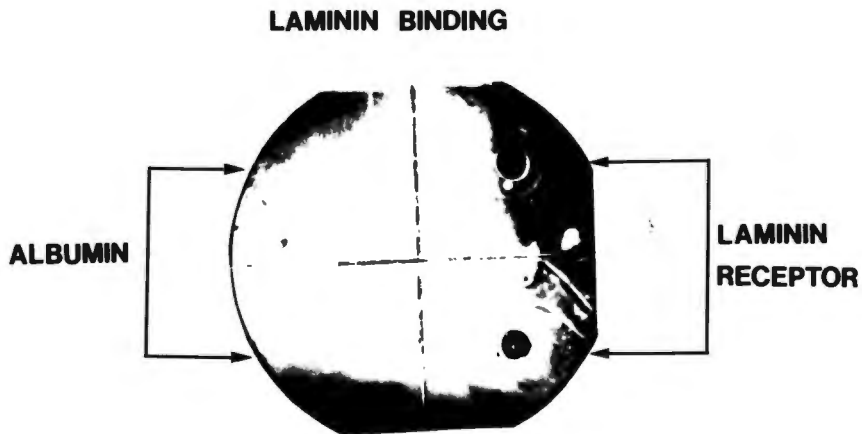
Plate 7. Laminin binding to isolated receptor.

Specific binding of laminin to the receptor, with no binding to the high concentration of human albumin controls.

CONCLUSIONS:

The human platelet membrane component is identical to the well characterized laminin receptor from the membranes of human breast carcinoma cells, in elution pattern expression and molecular weights. It binds laminin in a specific way. A 67kDa laminin receptor on human platelets has thus been identified. This is the first time that such a receptor has been discovered on platelets.

IV. ADDITIONAL CONFIRMATION

A series of observations have appeared and these are briefly summarised below:

STUDY	FINDING
Perfusion +/- anti-laminin antibodies (Ordinas et al, 1992)	Decreased adhesion with antibodies
Platelet incubation with antiserum to 67kDa receptor	Intense labelling on flow cytometry
Laminin-Sepharose elution of cold/labelled membranes	67kDa eluted, monitored by spectroscopy, radioactivity
Immunoinhibition with antibodies to 67kDa receptor	Decreased adhesion
Adhesion to laminin-derived peptides	Adherence
Blocking of membranes with laminin-derived peptides	Partial inhibition
Membrane binding to peptide-Sepharose columns (Tandon et al, 1991)	Recovery of 67kDa protein

A. PERFUSION STUDIES

The possible physiologic relevance of the platelet laminin receptor to cellular interaction with the subendothelium in whole blood was supported in studies using abdominal aorta segments in the Baumgartner annular perfusion chamber. The evaluation was carried out according to the basic criteria described by Baumgartner (1973) with minor modification (Bastida et al, 1986). The segments were incubated with either PBS, Fab fragments of a rabbit anti-mouse laminin antibody (50ug/ml) or a similar concentration of an irrelevant antibody. After perfusion with anticoagulated whole blood from normal healthy donors who had not taken any

drugs in the previous 10 days, they were rinsed and fixed with glutaraldehyde. Morphometric evaluation of embedded and stained specimens was then employed, using a manual optical picture analysis system (MOP 20 Kontron), connected to a computer with an automated recognition programme.

Results and comment:

Pre-incubation of the vessel segments with anti-laminin antibody (F_{ab}), led to reductions in the total surface coverage, the percentage of spread platelets and the percentage of aggregates less than 5µm in height (p<0.005). These findings are consistent with the interaction found in the laboratory and provides evidence of specific laminin recognition in the physiologic response of platelets to injury to vascular endothelium. This also provides support for the hypothesis of this thesis, relating to the facilitating role of this receptor in lodgement of platelet-tumour emboli in vivo (see The Role of Platelets in Metastasis in next section).

B. FLOW CYTOMETRY

Washed platelets were incubated with polyclonal rabbit antiserum to the 67kDa laminin receptor isolated from human breast carcinoma tissue, with controls exposed to normal rabbit serum. Fluorescein isothiocyanate labelled goat anti-rabbit IgG (Cooper Biomedical, Malvern PA) was used as the second antibody, and the signal measured with a flow fluorocytometer (EPICS Coulter Corporation, Hialeah, Fl).

Results and comment:

The antibody to the 67kDa laminin receptor produced an intense fluorescent signal as compared with normal IgG, indicating that about 99% of the platelets were labelled. Thus the surface location of the receptor is confirmed, which has strong affinity for laminin.

C. RECEPTOR ELUTION FROM LAMININ-SEPHAROSE COLUMN

Affinity chromatography with columns prepared according to methods described in the present study (See Preparation of the laminin-Sepharose column) were used to monitor the binding of labelled and 'cold' platelet receptors. Crude membranes from one unit of ^{125}I -labelled platelets were mixed with 20 units of unlabelled membranes, dissolved in Triton X-100 and applied to the column, which was washed with application buffer until the absorbance and radioactivity in the eluate had fallen to approximately baseline values. Stepwise elution was then initiated with collection of 4ml fractions and the pH adjusted to 7.6 with 75ul of 1M Tris.

Results and comment:

There was a rapid fall in the radioactivity with washing of the column with buffer. Subsequent elution demonstrated peaks with the following:

- 1M NaCl, followed by a drop back to the baseline;
- Glycine/HCl containing Triton X-100 produced a major peak of strong absorbance which cleared the column of radioactivity, SDS added to the elution buffer produced no further peaks.

In the eluates of unlabelled platelet membranes monitored by u-v absorption against Triton X-100 in the reference cuvette, glycine/HCl caused a major decrease in the absorption. These results are shown in Plate 8.

SDS /PAGE of the glycine/HCl fraction concentrated by Amicon Centricon (PM30) filtration confirmed the elution of the 67kDa (reduced) and 53kDa (unreduced) platelet membrane component. Protein blotting using a polyclonal antibody prepared against the 67kDa laminin receptor of human breast carcinoma confirmed their immunological identity.

The elution pattern, molecular weights as well as the cognate binding of antibodies for platelet membranes is thus

reproducible and similar to that of breast cancer cell (Barsky et al, 1984b).

Plate 8. Elution pattern from laminin-Sepharose

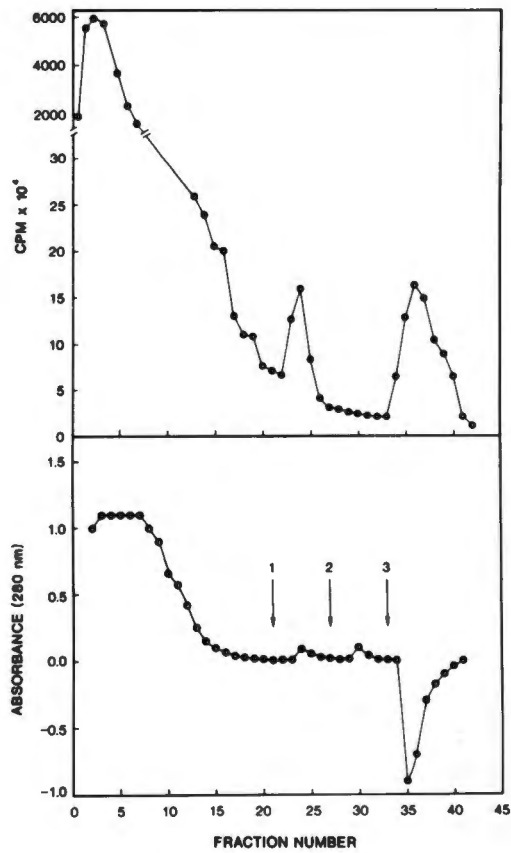

Elution peaks with radioactivity (a) and absorbance (b) obtained with 1M NaCl (arrow 1), buffer containing 5mM EGTA (arrow 2), and finally 0.2M glycine/HCl containing 0.1% Triton X-100 (pH 2.85) (arrow 3).

D. IMMUNOINHIBITION WITH MONOCLONAL ANTIBODIES

Immunoglobulins (3D1 and 6G4) raised against the LR-1 peptide sequence in the 67kDa laminin receptor of malignant cells were incubated with platelets before they were added to the micro-titre plates in the adhesion assay.

Results and comment:

There was a 50-60% inhibition of adhesion while an irrelevant anti-Factor IX antibody was without effect (Plate 9). This confirms the immunologic identity to the 67kDa receptor of breast carcinoma cells. Of significance, the immunoinhibition was not total, indicating the probable involvement of other platelet membrane receptor systems, and supports the working hypothesis of this thesis that both the VLA-6 (Sonnenberg et al, 1988) and the 67kDa receptor are required for optimal platelet adhesion to laminin.

Plate 9 Immunoinhibition of platelet adherence.

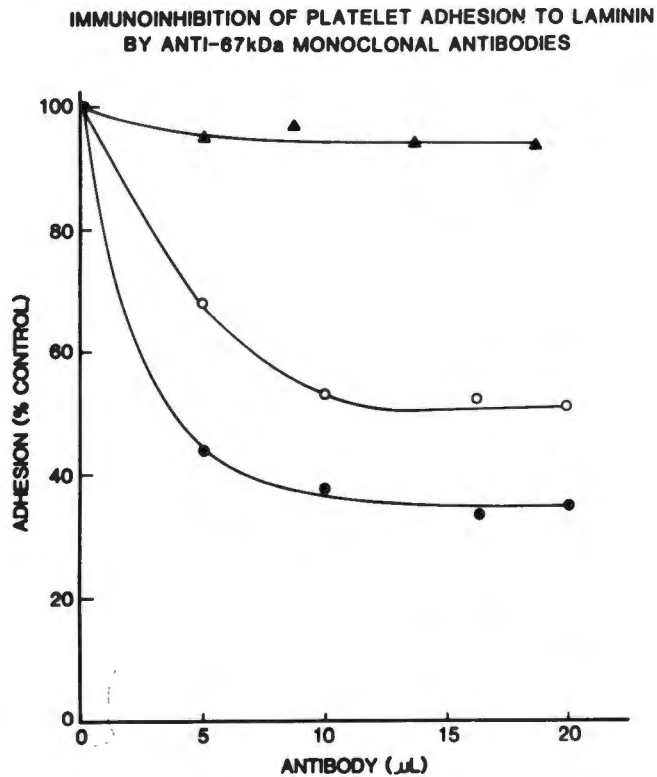

Immunoinhibition using the standard micro-titre assay and culture supernatants containing IgM monoclonal antibodies. Bottom: 6G4 and Centre:3D1, anti-bodies raised against the human tumour cell laminin receptor. Top: Negative control antibody (anti-human factor IX). The points shown are the averages of two determinations each carried out in triplicate.

E. PEPTIDE ADHESION STUDIES

Two laminin-derived peptides, a pentapeptide, Tyr-Ile-Gly-Ser-Arg and an octapeptide, Cys-Asp-Pro-Tyr-Ile-Gly-Ser-Arg-NH₂ as described by Graf et al (1987) in a range of concentrations (0.1-150ug) were applied to the micro-titre plates and dried overnight. An irrelevant peptide Gly-Ala-Arg-Gly served as a negative control and 8ug laminin as the positive control. After blocking with albumin, the ⁵¹Cr-labelled platelet adhesion assay was carried out as described.

Results and comment:

These peptides, derived from the critical site of laminin to which the 67kDa breast cancer receptor binds, support adhesion (Plate 10). They are thus recognised by receptors on the platelet membranes. This provides evidence that the related structures have a similar affinity for this site of the laminin molecule. Of note is that the binding efficiency decreases with truncation of the proteins.

In another study these peptides at a concentration of 1mM, were pre-incubated with platelets for 30 minutes prior to adding to the laminin-coated plates in the adhesion assay.

Results and comment:

PEPTIDE	% INHIBITION
Tyr-Ile-Gly-Ser-Arg	51
Cys-Asp-Pro-Tyr-Ile-Gly-Ser-Arg-NH ₂	57

The partial blocking of the membrane site responsible for the adhesion by these peptides derived from the B1 short arm of the laminin molecule and specifically recognized by the

breast cancer membrane 67kDa receptor, suggests that the platelet membrane has similar recognition specificity.

Plate 10. Adhesion of platelets to laminin-derived peptides

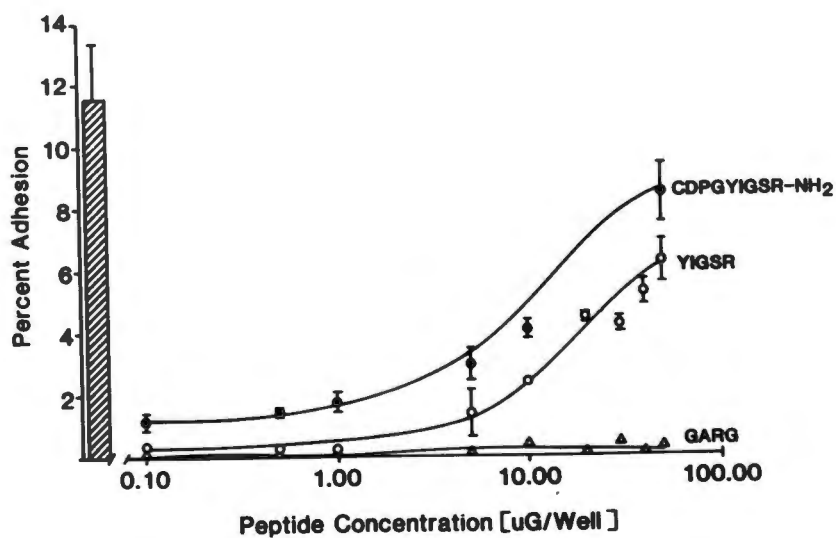

Means of adhesion +/- SD for three separate experiments, each performed in triplicate. Top: Octapeptide. Centre: Pentapeptide. Bottom: Gly-Ala-Arg-Gly(negative control). The vertical bar shows binding to laminin(8ug/well) as a positive control.

F. LAMININ FRAGMENT SEPHAROSE COLUMN STUDIES

The Cys-Asp-Pro-Tyr-Ile-Gly-Ser-Arg-NH₂ peptide was linked to 2B-Sepharose, a Triton X100-solubilized platelet membrane preparation was cycled over the columns and the bound components eluted as described (see above). The glycine-HCl eluate fractions were concentrated with an Amicon Centricon (PM30) apparatus and studied with SDS-polyacrylamide gel electrophoresis.

Results and comment:

This revealed a dense band of the 67kDa (reduced) receptor. The immunologic identity this receptor with the 67kDa counterpart of human breast carcinoma cells was established by protein blotting using polyclonal antibodies.

The avid binding of the 67kDa platelet membrane component to the Sepharose column to which the peptide derived from the B1 short arm of the laminin molecule was linked, confirms the specificity of the membrane binding site. As this peptide forms the essential part of the complementary domain critical for the recognition by the breast cancer membrane 67kDa receptor (Graf et al, 1987), the identical molecular weights, and the immunological identity on protein blotting provides overwhelming evidence that the 67kDa platelet membrane component is a receptor for laminin.

V. CONCLUSIONS AND IMPLICATIONS.

THE MICRO-TITRE ASSAY

A micro-titre assay has been developed to evaluate the adhesion of platelets to laminin, a major glycoprotein of the basement membrane. It is simple to set up, rapid, reproducible, specific and economical in the use of reagents. From this baseline, a number of variables were investigated.

Ill et al (1984) were the first to describe this phenomenon, using coated petri-dishes, but required large volumes of reagents. This was addressed by the assay developed by Sonnenberg et al (1988) who used Greiner micro-titre plates. The present assay was a modification of this, but used highly absorptive micro-titre plates (Maxisorp Nunc-Immuno, Nunc, Denmark), which allowed adequate and constant adhesion, thus facilitating the investigation of the membrane interactions in the adhesion process.

Applying this approach, previous observations relating to the specific cation requirement have been extended. Ill et al (1984) used Dulbecco's modified Eagle's medium, which contains 1.8mM Ca^{2+} and 0.8mM Mg^{2+} . A wide range of these cations were individually tested in the study of Sonnenberg et al (1988), including Mg^{2+} which was shown to support adhesion and Ca^{2+} which inhibits it. The present assay has demonstrated the increasing adhesion with increasing concentrations of Mg^{2+} , where Ca^{2+} was found to effectively stop the increase when above a concentration of 0.5mM.

New information about the platelet membrane receptor for laminin is provided:

- First of all, its binding is not enhanced by prior platelet activation with the two powerful platelet agonists, ADP and thrombin. In fact, there is a drop in adhesion with

thrombin activation, due most likely to conformational change induced by its binding to the platelet membrane. It is also possible that the receptor site is interfered with through its proteolytic properties.

- Secondly, it is removed by both trypsin and chymotrypsin, which rapidly decreases adhesion, but not by the *Serratia marcescens* metalloprotease which, although it removes glycoprotein Ib (Cooper et al, 1982), has no effect on adhesion, and so excludes the involvement of the latter glycoprotein. However, since GPIIb is not removed by trypsin, and GPIV, the fibrinogen receptor (Greenberg et al, 1979a) and the thrombin receptor (Tam et al 1980) is not affected by chymotrypsin, the decreased adhesion of platelets treated with these enzymes excludes their involvement in mediating the adhesion.

- Thirdly, neither glyocalicin or GPIV could have any role, since adhesion was unaffected in the presence of antibodies to these adhesive receptors.

- Fourthly and definitively, GPIIb/IIIa was discounted as having any participation in the process, as platelets from two individuals with Glanzmann's Thrombasthenia, who lack this receptor, adhere normally.

- Finally, a fifth point currently of undetermined physiologic significance, is the marked inhibition of adhesion in the presence of the adhesive plasma proteins, fibrinogen and von Willebrand factor.

Combining all the available data, it is possible to tabulate the current knowledge about the platelet laminin receptor:

ENTITY	INFLUENCE ON ADHESION
Cations	
Mg ²⁺ , Mn ²⁺ Co ²⁺	+
Ca ²⁺ , Zn ²⁺ , Cu ²⁺	-
Activation	
ADP	0
Thrombin	-
Membrane Proteolysis	
Trypsin	-
Chymotrypsin	-
<i>S. marcescens</i> (GPIb removal)	-
Membrane glycoproteins	
GPIb	0
vWF receptor	0
Thrombin receptor	0
GPIII	0
GPIIb/IIIa receptor	0
GPIV	0
Adhesive proteins	
(Non-specifically bound)	
Fibrinogen - low conc.	++
Fibrinogen - high conc.	--
vWF	-
RGDS peptide	0

THE PHYSIOLOGY OF THE 67KDA RECEPTOR FOR LAMININ ON PLATELET MEMBRANES

More receptors for the many forms of laminin, and also in a wide variety of species, have been identified than actual active sites on the molecule (for recent review, see Mecham, 1991). These include nonintegrins, a 110kDa protein, galactose-binding lectins, sulfatides, galactosyl-transferase, and a variety of integrins. It is not clear why so many receptors for laminin exist. It is possible that multiple receptors on different cells can recognise the same active site, and integrin receptors can recognise multiple extracellular matrix components, even varying with different cell types (Kleinman et al, 1993).

Recently an alternative site for the interaction between laminin and the 67kDa receptor was established by electron microscopy, using the rotatory shadowing technique (Cioce et al, 1993). The laminin receptor used was purified from human colon carcinoma metastases, and appeared as a globular structure with a diameter of 5.2 ± 0.8 nm. The receptor specifically bound to laminin on its long arm, close to the intersection of the long and short arms. Furthermore, the receptor bound only laminin fragments obtained from enzymatic digestion that retained a short piece of the long arm (chymotrypsin), and not to a pepsin digest (P1 fragment) which removed that part of the long arm. The binding site for the 67kDa receptor has thus been identified as a region on the long arm of laminin, close to the intersection of the four arms.

Given the overwhelming evidence in support of the 67kDa platelet membrane component being a receptor for laminin presented in this thesis, the conclusion must be drawn that it operates in a complementary system with the VLA-6 integrin.

Antibody to the Ic (alpha) subunit of VLA-6 inhibits platelet adhesion to laminin (Sonnenberg et al 1988) which clearly establishes its role as a receptor for laminin. The central role of the isolated 67kDa receptor in specific adhesion of platelets to laminin finds support in a variety of ways:

OBSERVATION	METHOD
Laminin binding	Protein blotting
Immunologic identity to cancer cell 67kDa receptor	Protein blotting and flow cytometry: with anti-67kDa
67kDa-specific platelet membrane function in adhesion	Decreased platelet adhesion with anti-67kDa.
Receptor specific for 67kDa cognate site on laminin	Inhibited platelet adhesion with peptide pre-incubation
Specific recognition of cognate site on laminin	Cognate peptide affinity-chromatography

However, as shown earlier, monoclonal antibodies 3D1 and 6G4 raised against the LR-1 peptide sequence of the 67kDa laminin receptor of breast carcinoma cells only cause a 50-60% inhibition of adhesion in the micro-titre assay. This together with the observation of an initial lag phase in the first 10 minutes of the adhesion in the time course study (Study 3), suggests that other receptors for laminin must be present for optimal adhesion.

A similar conclusion was drawn to account for the variation of receptors recovered when different laminin fragments were studied by affinity chromatography (Sonnenberg et al 1991). VLA-6 adheres to affinity columns when platelet lysates are passed over them (Sonnenberg et al, 1991). These columns however, carried the E8 laminin fragment, with similar results for both murine and human laminin. When coupled with

the P1 murine laminin fragment, a different receptor, GPIIb-alpha3 (GPIIb/IIIa) was recovered. The linkage of the intact laminin molecule, as has been used presently, was not studied in any of the isolation procedures, thus as expected, the 67kDa receptor was not eluted.

In the present work, only the 67kDa receptor was recovered both when the intact laminin and the B1 peptide containing the critical YIGSR sequence was linked. These results are tabulated below.

	E8 FRAGMENT	P1 FRAGMENT	COMPLETE LAMININ	B1 PEPTIDE
RECEPTOR				
VLA-6	+	-	-	-
GPIIb/IIIa	-	+	-	-
67kDa	-	-	+	+

The variant findings could be due to a number of factors: The importance of the particular laminin fragment attached to the affinity column in determining the receptor recovered in the eluate has been stressed in other cell systems. Gehlsen et al (1988) isolated an integrin receptor (two protein bands with molecular weights of 150 and 120 kD in nonreducing conditions) from human glioblastoma cells. However, as with Sonnenberg, they used a pepsin extract of human laminin coupled to the Sepharose. The fragment thus obtained is located in a different region of the laminin molecule from that of the YIGSR site, which binds the 67kDa receptor. Accordingly, they found no indication of a surface-labeled 67kDa protein in their affinity chromatography fractions, and the YIGSR peptide did not inhibit the binding of this receptor to laminin.

Secondly, there probably are many homologous peptide sequences amongst adhesive proteins, and thus fragments of these molecules could be recognized by different members of the integrin superfamily. Thus caution should be exercised in attributing a receptor role for components on the basis of their recovery from laminin fragment affinity columns.

Lastly, the species from which the laminin was obtained may also influence the binding by laminin receptors. The laminin for the present study was isolated from the basement membrane of the Engelbreth-Holm-Swarm transplantable murine tumour. The Ae, B1e, and B2e chains of this laminin have been sequenced (Sasaki et al, 1988). Sequences of human A, B1, and B2 chains were determined (Nissinen et al, 1991; Haaparanta et al, 1991; Pikkarainen et al, 1987, 1988) and found to be 75-85% homologous to the corresponding mouse Ae, B1e, and B2 chains. Intact human placental laminin stimulates cell attachment of rat, human and mouse cells, with similar concentration dependency and kinetics to EHS laminin (Brown and Goodman, 1991). And although the microscopic form of human placental laminin is similar to the EHS molecule, some biological activities are not. Not only is the coiled-coil alpha helix in the long arm considerably more thermally stable than in EHS laminin, but also it is apparently not recognised by the same receptors. Initial studies indicate that alpha6/beta1, for example, is not the major cell surface receptor for human laminin, either on murine or human cells (Goodman, 1992). Thus it would be important to carry out the isolation procedure for the platelet 67kDa receptor using a whole human placental laminin affinity column to verify the findings of the present work. Intact molecules from species other than mouse, and sources other than tumour basement membrane have not been available in quantities sufficient for cell biology until recently. A simple and rapid purification of tumour laminin was devised, and used to isolate for the first time intact normal laminin from murine heart (Paulsson et al,

1987; Paulsson and Saladin, 1989). However, both murine and human E8 laminin fragments were used in the affinity chromatography, with identical platelet membrane components recovered in the eluate (Sonnenberg et al, 1991).

Nevertheless, there are parallels of receptor pleiotropism in the binding of macrophages to laminin. Freshly isolated human peripheral blood monocytes adhere strongly to laminin, while that to fibronectin is weaker, with the weakest to collagen (Tobias et al, 1987). With the use of virtually identical isolation procedures as used in the present study, the receptors bound to laminin in a dose-, time- and temperature-dependent manner and have a molecular weight identical to those of tumour cells and platelets (Huard et al 1986). They too are susceptible to trypsin proteolysis and are immunoprecipitated by antibodies to the 67kDa receptor (Mercurio and Shaw, 1988). This evidence establishes its role as a receptor for laminin. However, large amounts of VLA-6, and moderate amounts of VLA-4 and VLA-5 are located on the membranes of macrophages, which also play a role in the adhesion (Hemler 1990).

It is thus proposed that the integrin receptors VLA-6 and possibly GPIIb/IIIa, together with the non-integrin 67kDa receptor, are complementary systems governing the adhesion of a wide variety of cells to the laminin of basement membranes. This is represented diagrammatically below:

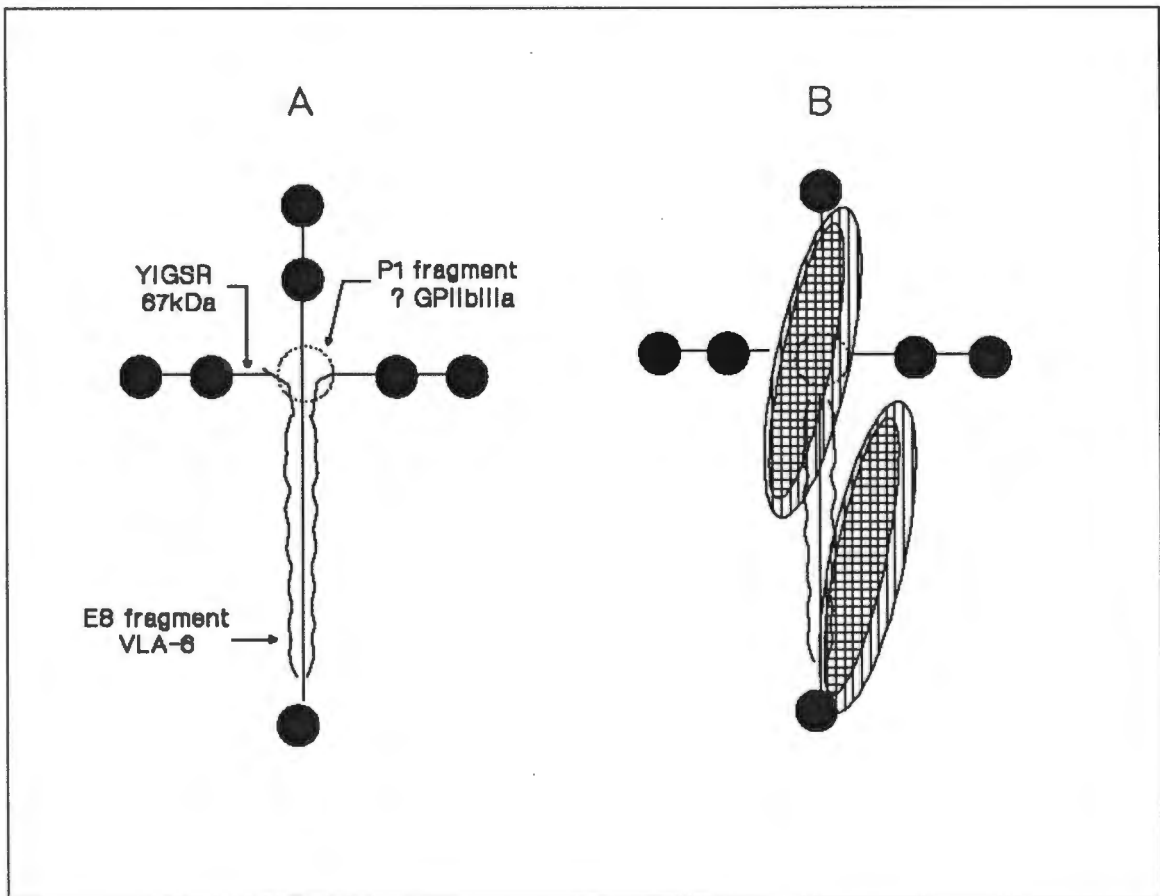

- A. Laminin molecule with cognate receptor for each binding site.
 B. Cell binding, all sites operative for maximal cell binding

THE ROLE OF PLATELETS IN METASTASIS

INTRODUCTION

The spread of cancer is not a random event, but a series of sequential, interlinked steps, in which a tumour cell must complete a series of potentially lethal interactions with various host factors (Poste and Fidler, 1980; Jamieson et al, 1987). The sequence is described in five steps, namely:

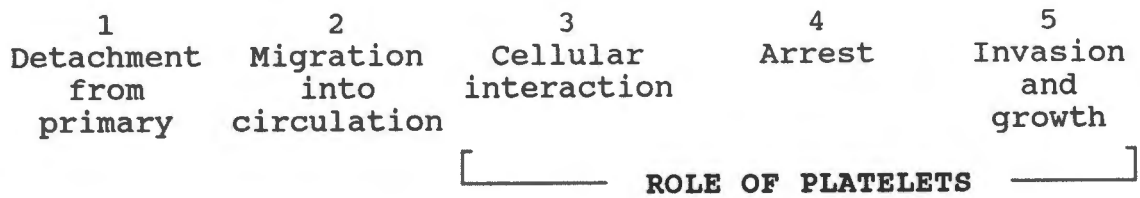

Once at the target site, cells invade tissues in a series of stages as proposed by Liotta et al (1977):

- i) Binding to components of the basement membrane.
- ii) Degradation of the basement membrane by hydrolytic enzymes derived from the neoplastic cells or host cells stimulated by the tumour. Defects of the basement membrane have been demonstrated adjacent to the invaders in the stroma (Burtin et al, 1982).
- iii) Extrusion of a pseudopodium through the defect in the basement membrane and locomotion into the matrix.

THE ROLE OF PLATELETS IN METASTASIS

There is some evidence to support the view that the presence of platelets has an adverse effect on tumour cell survival. Cytotoxic effects exerted by the arachidonate metabolites of platelets have been shown to enhance killing in a monocyte-tumour cell cytotoxicity assay (Ibele et al, 1985). However there is overwhelming evidence that the interaction of platelets with tumour cells during the initial period of four to six hours, promotes the process in experimental metastases studies (Gasic and Gasic 1962, Gasic et al 1968, Pearlstein et al 1984, Crisman et al 1985). In vitro clonogenicity occurred inversely with the degree of thrombocytopenia.

Central to the facilitating role of platelets, is their activation when coming into contact with metastatic cells that have entered the circulation, then aggregating around them to form a tumour cell-platelet embolus.

In cell lines this appears to principally involve either thrombin- or ADP-mediated activating mechanisms (Bastida et al, 1981, Bastida et al, 1984, Bastida et al, 1985). Sources of the agonists include:

THROMBIN	Tissue factor on surface Contained within microvesicles
ADP	Secretion Contained within microvesicles

i) Generation of thrombin:

This process, distinct from the intrinsic and extrinsic pathways of coagulation, is by tissue thromboplastin (Gordon et al 1979) and occurs within factor VIII- and factor VII-deficient human plasma (Curatolo et al 1979). In the human glioblastoma cell line - U87MG, thrombin-containing microvesicles are formed. These are 200nm in diameter on electron microscopic examination, and have both a procoagulant and a platelet-aggregant effect. In perfusion studies using a Baumgartner apparatus, these microvesicles produced large, complex platelet thrombi (Bastida et al 1984).

ii) Release of Adenosine Diphosphate (ADP)

This was found in suspensions of human lymphoma cells, certain of the Chang strains of human liver cells (Holme et al 1978), later in an undifferentiated murine cell line - Hut20 (Bastida et al 1981), and demonstrated to cause rapid aggregation of platelets.

iii) Release of Cathepsin B:

This cysteine proteinase degrades pericellular protein at pH 7.1, is found within the lysosomes in murine B16 melanoma cells, and causes platelet aggregation (Honn et al, 1983). The variant with high metastatic potential - B16-F10 had higher activity than the variant with low metastatic potential - B16-F1.

The aggregation of platelets around the metastatic cells provides them with a protective shell, promoting their spread (Jamieson et al 1987). The considered pathophysiological mechanisms are:

i) Shielding from host defense mechanisms mediated by polymorphonuclear leucocytes, T-lymphocytes and natural killer cells, which are important in preventing metastases (Hanna, 1982).

ii) Protection from the turbulence of the blood flow.

iii) Platelets provide enzymes like heparan sulphate at metastatic sites, to assist in the degradation of extracellular matrix tissue (Oldberg et al, 1980). This could be particularly important for cells of low metastatic potential which degrade matrix tissue less effectively than their more malignant counterparts, as has been demonstrated with B16 melanoma cell lines (Nakajima et al, 1983).

iv) Increased vascular permeability facilitates the migration of tumour cells into parenchymatous tissues. This is provided by alpha granule constituents such as platelet basic protein (Paul et al, 1980), beta thromboglobulin, platelet factor 4, dense granule components like histamine and serotonin (Nachman, 1978) and prostaglandins (Honn et al, 1983).

v) Chemotactic activity from platelet-derived growth factor released from the alpha granules assists in cell migration into the subendothelial tissues (Grotendorst et al, 1981).

vi) Stimulatory peptides promoting mitogenic activity, like platelet derived growth factor, transforming growth factor and epidermal growth factor-like peptide acting in concert (Assoian et al, 1984).

The metastatic process is inefficient, fewer than 1% of radiolabelled tumour cells are viable 24 hours after being injected into the circulation of syngeneic mice, as a result of immune-surveillance mechanisms (Fidler 1973). The

protective and promotive mechanisms are thus likely to be important. They are summarized diagrammatically below:

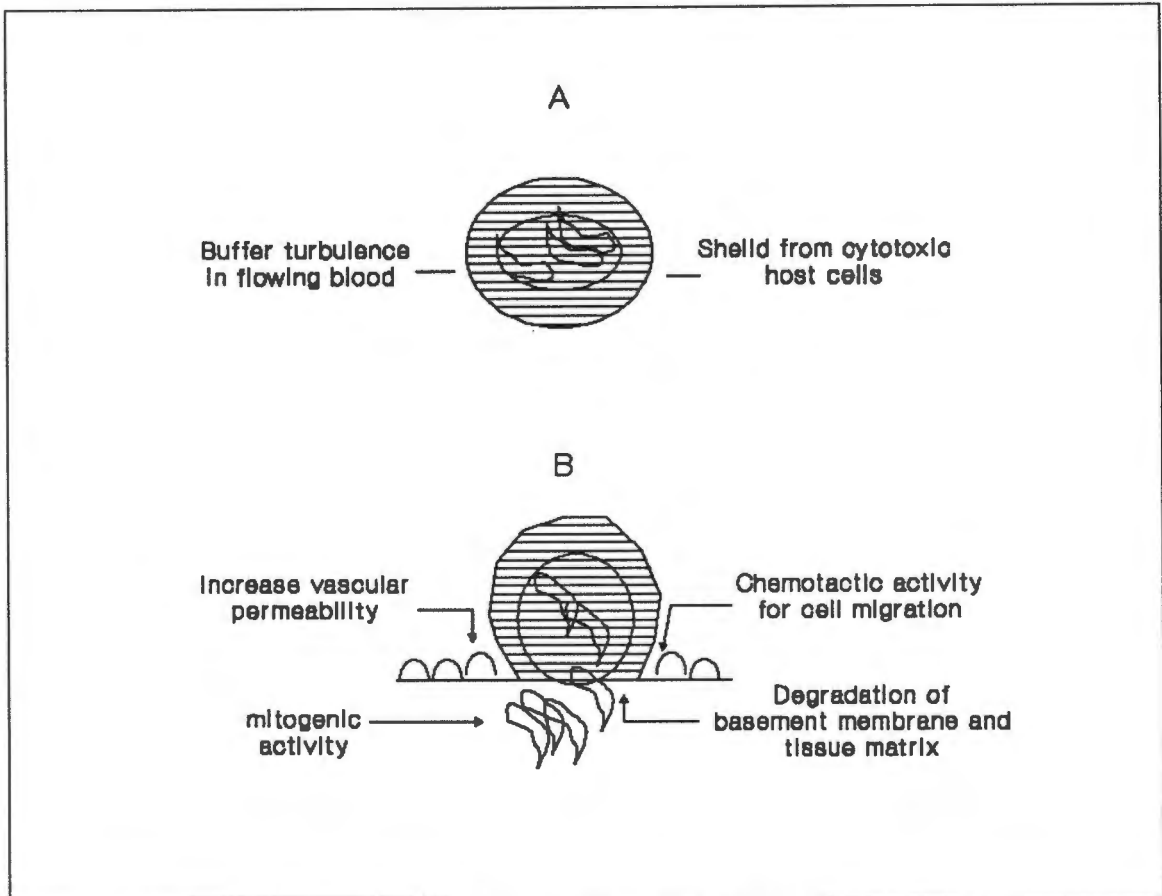

A. Protective function of platelet shell within circulation.
B. Promotive function at site of lodgement

The relevance of the present work revolves around the process of lodgement of the embolus within vascular beds. The original postulate for the role of platelets was based on autopsy studies, where tumour cells were frequently found in association with platelet thrombi (Billroth 1878). These observations have been repeatedly confirmed over the years. Such thrombi were demonstrated with the use of microcinematography in a rabbit ear chamber model (Wood, 1958) and light and ultrastructural studies (Jones et al 1971, Warren and Vales 1972, Sindelar et al 1975).

What remains controversial is the manner in which this is achieved. Two proposed mechanisms whereby platelets promote invasion are diagrammatically illustrated below:

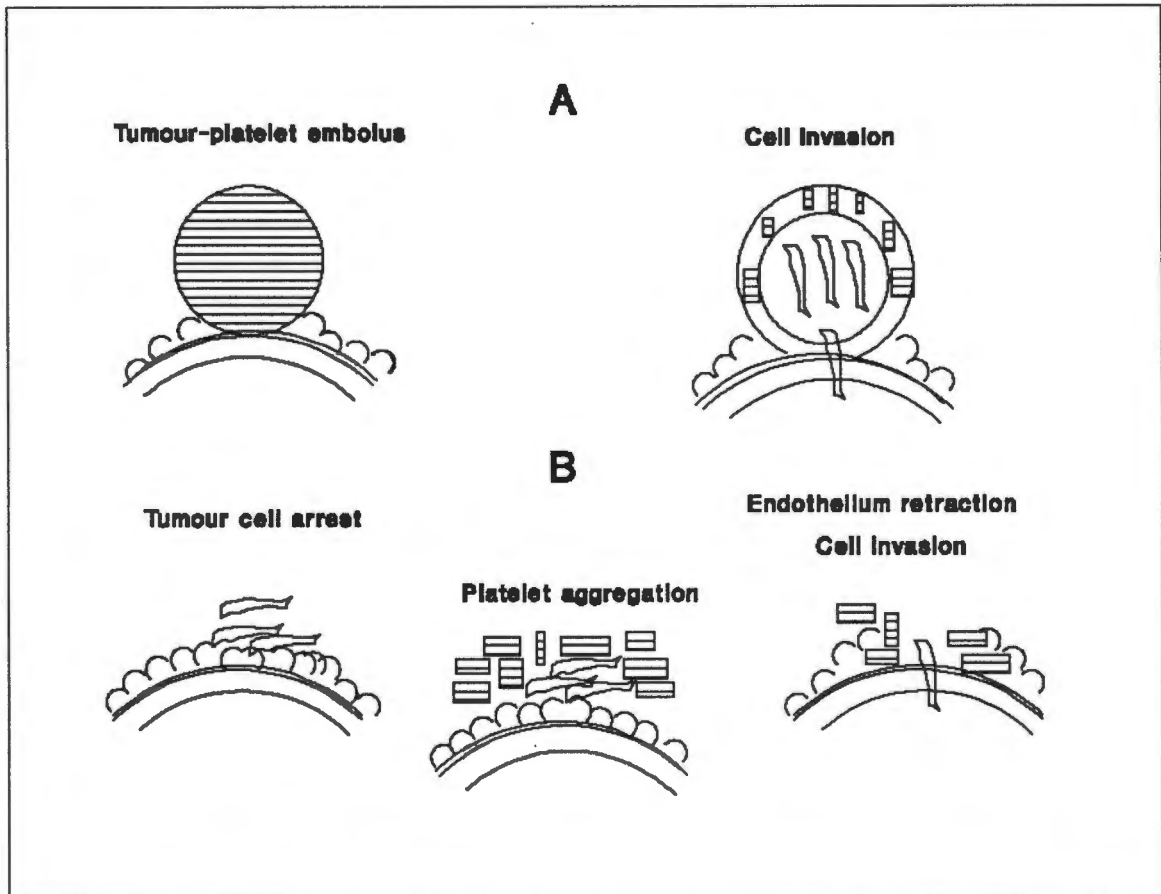

- A. Lodgement of the embolus, platelets reacting with vessel wall constituents, followed by invasion.
- B. The initial interaction of the tumour cells with the vascular endothelium, with platelet activation following invasion and exposure of the subendothelial tissues.

There is support for both these mechanisms. For B: Rats made thrombocytopenic with anti-platelet serum have a 53% reduction of rat fibrosarcoma cells in the hepatic biopsies after direct intra-portal injection (Skolnik et al, 1984). However, previous studies by this group did not identify any platelet involvement in the early phases of their experimental metastasis model when viewed by electron microscopy (Bagge et al, 1983). The enhancing effect was thus thought to be due to amine release upon aggregation

after initial tumour cell adhesion to subendothelial tissues. In other studies (Crissman et al 1985, 1988), minimal platelet association or activation was evident in the first 2 minutes, when the tumour cells were already in juxtaposition to the endothelial cells. Aggregation commenced within 2 to 10 minutes, with the formation of a stable thrombus in the next 4 hours. This supports the proposal that the thrombus is generated secondary to lodgement, adhesion and penetration of the neoplastic cells, exposing the subendothelial tissues, which activates platelets. Tumour cells produce cytokines, including interleukin-1, which induce the expression of surface glycoproteins like ICAM-1 and E-selectin by the vascular endothelium (Rice and Bevilacqua, 1989, Hawrylowicz et al, 1991), thus promoting their own adhesion. Their surface receptors for matrix proteins like laminin (Liotta, 1986) would allow direct interaction with subendothelial tissues.

However mechanical entrapment of the embolus as the initial process is also supported. Using Walker 256 cell infusions into Sprague-Dawley rats, Jones et al (1971) noted that at 2 minutes they were loosely attached to the endothelium or lying free in the circulation, surrounded by loose clusters of platelets, developing into compact masses in 2 hours. By 3 to 8 hours the cells were still completely intravascular, with very little breaching of the endothelium and basement membrane. This only became apparent after 9 to 14 hours, at a stage when the platelets had virtually disappeared. In other studies, inoculated melanoma cells were associated with platelets and fibrin in the early stages, and only slightly attached to the endothelial cells of lung capillaries (Lapis et al, 1988). The latter then retracted, and after the tumour cells became tightly attached to the basement membrane, migrated over their surface, probably in response to the attraction of growth factors derived from the platelets. The tumour cells only started to penetrate

the basement membrane after they were covered by the endothelial cells.

This mechanisms by which platelets could mediate this role are multiple:

- As seen with scanning electron microscopy, platelet membranes form an adhesive bridge between tumour cells and the subendothelial matrix, a phenomenon considered as critical for the process of invasion (Menter et al, 1987).
- Release of serotonin to facilitate the widening of the diameter of the open endothelial intercellular junctions, which in their resting state, are 30-60nm in diameter, too small for the penetration of any cells (Simionescu et al, 1978). The filipodia of the platelets could then penetrate these gap junctions, to cause retraction of the endothelium and damage to the basement membrane and submembranous tissues by its heparan sulphate degrading enzymes.
- B16 melanoma cell-stimulated platelets greatly enhance tumour cell adhesion to endothelial cell monolayers (Tohgo et al, 1990), causing retraction of the endothelial cells, allowing greater interaction of the tumour cells with the subendothelial matrix.

THE RELEVANCE OF THE PLATELET LAMININ RECEPTOR

The tumour cell-platelet embolus will have receptors for the most abundant glycoprotein of the basement membrane well represented on the surface. These could serve to anchor the thrombus to vascular beds, facilitating migration of the motile malignant cells through the basement membrane. Anti-laminin antibodies decrease the coverage of vascular segments by platelets in flowing blood, with significant decreases in spreading and aggregation on the surface (Ordinas et al, 1992, detailed in confirmatory studies, Page 76). These findings point to an important contribution of laminin receptors in the lodgement of platelet-tumour cell emboli.

THE RELEVANCE TO ONCOLOGY

The essence of cancer research is to acquire insight into the fundamental mechanisms of oncogenesis, invasion and metastasis, with the hope of identifying specific biochemical factors that can be used in diagnostic or therapeutic strategies (Liotta, 1986).

In their dissemination, a cardinal characteristic is the capacity of tumour cells to degrade basement membrane, which is greater than their counterparts at the primary site (Liotta et al, 1977). Thus those carried to the sites of secondary spread are a distinct subpopulation with enhanced invasive potential.

Therapeutic options must consider inhibition of each step in the sequence (Bastida, 1988). The control of the platelet activation by antiplatelet drugs remains controversial (Cazenave et al, 1978; Zacharski, 1984; Jamieson et al, 1987). The phosphodiesterase inhibitor, RA-233 (mopidamol) has been shown to limit progression of tumours in experimental models. RA-233 was also shown to be of benefit in a large trial of patients with cancer, but the it was not a controlled one (Zacharski et al, 1982). A later randomized VA Cooperative Study (CSP#188) used chemotherapy with and without RA-233 in patients with carcinoma of the lung or colon. After a minimum of one year follow up, the drug was shown to be of benefit for only a single sub-group of patients - those with non-small cell lung carcinoma limited to one hemithorax (Zacharski et al, 1987). There thus appears to be a crucial need for more selective anti-platelet agents.

The thrust of the present work relates to the established pathophysiological feature at this stage of the metastatic process, that the tumour cells are surrounded by a shell of platelets. In their capability to insulate tumour cells from host defense mechanisms, and buffer the mechanical trauma of the turbulence of the flowing blood, the platelet shell

contributes to their survival. In addition, they are provided with enzyme systems which degrade extracellular matrix tissue and increases vascular permeability, in this way enhancing their capacity to penetrate tissues. Growth factors promote their mitogenic and chemotactic activity, further assisting in cell invasion into the subendothelial tissues and clonal expansion.

The metastatic potential of breast carcinoma cells has been correlated with the number of unoccupied laminin receptors on their surface membranes (Barsky et al, 1984a). Treatment with the relevant binding fragments markedly inhibits or abolishes spread in a non-toxic fashion (Barsky et al, 1984b). Directing binding fragments at the platelets membrane would be of central importance, since it would interfere with the process at a critical point. The synthetic peptides which include the critical YIGSR sequence of the B1 chain which is recognised by the 67kDa receptor, have opened up exciting therapeutic possibilities. These peptides were used in a murine model of lung tumour colonization after the intravenous injection of B16F10 melanoma cells (Iwamoto et al, 1987). They decrease the ability of these cells to attack and degrade basement membrane matrix, impairing their migration though it by over 90%. Lung tumours were reduced by over 90%. Multiple intravenous administrations of polymers of the synthetic YIGSR monoepitope sequence, resulted in the reduction of lung colonies in experimental metastasis by over 80% (Saiki et al, 1989).

This present study has uncovered yet another mechanism which could impact at the most critical point of haematogenous spread. A receptor has been found on the surface of the enveloping cell aggregate, critical for invasion by the cancer cells, allowing them to anchor to and penetrate subendothelial tissues. This proposal is diagrammatically depicted below.

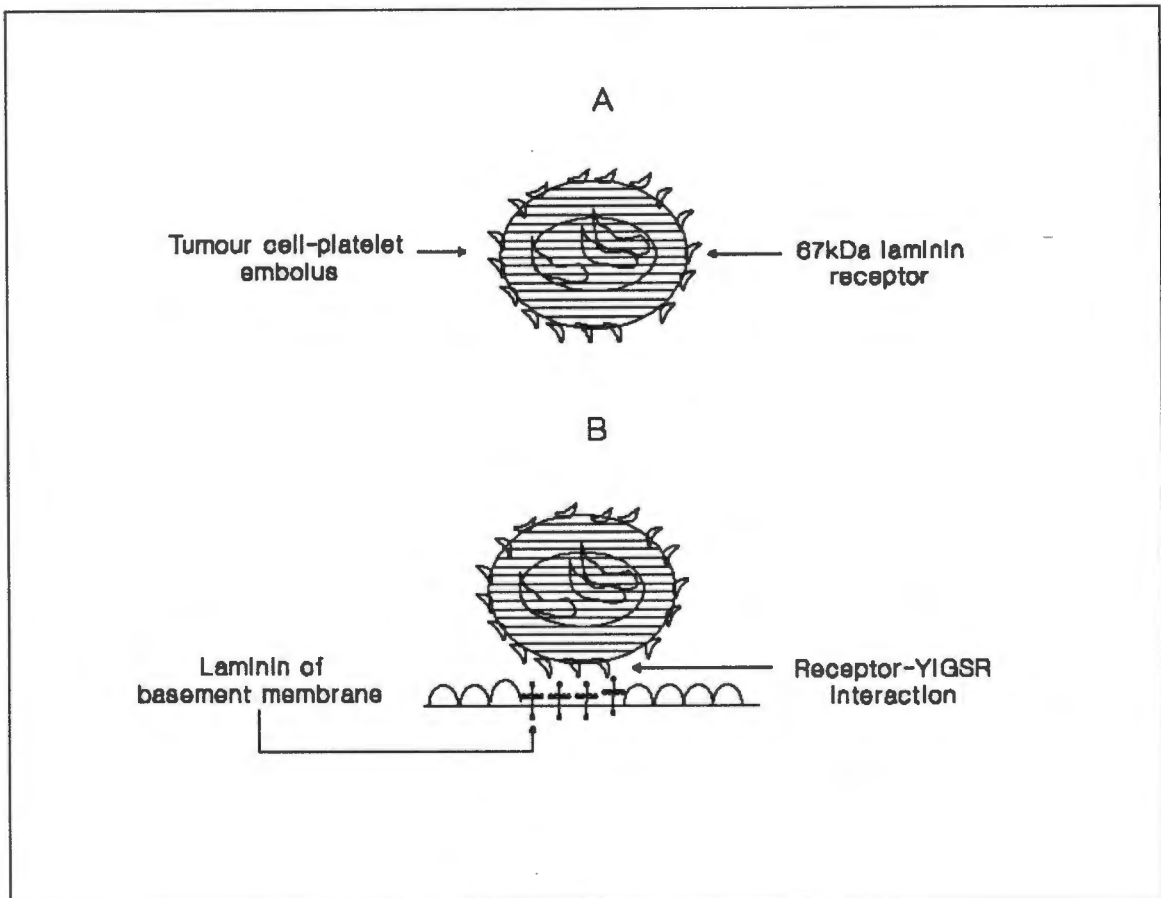

A. Embolus in circulation

B. Lodgement at site of secondary spread

Together with improved means to control their activation, the effective blockage of the 67kDa receptor of platelets discovered here, will introduce a meaningful therapeutic advance in the fight against cancer.

VI. REFERENCES

- Asch AS, Barnwell J, Silverstein RL, Nachman RL : Isolation of the Thrombospondin membrane receptor. *J Clin Invest.* 79, 1054, 1987.
- Assoian RK, Grotendorst GR, Miller DM, Sporn MB : Cellular transformation by coordinated action of three peptide growth factors from human platelets. *Nature.* 309, 804, 1984.
- Aumailley M, Gerl M, Sonnenberg A, Deutzmann R, Timpl R. : Identification of the Arg-Gly-Asp sequence in laminin A chain as a latent cell-binding site being exposed in fragment P1. *FEBS Lett.* 262, 82, 1990.
- Bagge U, Skolnik G, Ericson LE. : The arrest of circulating tumor cells in liver micro-circulation. A vital fluorescence microscopic, electron microscopic and isotope study in the rat. *J Cancer Res Clin Oncol.* 103, 134, 1983.
- Baron van Evercooren A, Kleinman HK, Ohno S, Marangos P, Schwartz JP, Dubois-Dalcq ME. : Nerve growth factor, laminin and fibronectin promote neurite growth in human fetal sensory ganglia cultures. *J Neurosci Res.* 8, 179, 1982.
- Barsky SH, Rao CN, Hyams D, Liotta LA. : Characterization of a laminin receptor from human breast carcinoma tissue. *Breast Cancer Res Treatment.* 4, 181, 1984a.
- Barsky SH, Rao CN, Williams JE, Liotta LA. : Laminin molecular domains which alter metastasis in a murine model. *J Clin Invest.* 74, 843, 1984b.
- Bastida E. : The metastatic cascade : Potential approaches for the inhibition of metastasis. *Sem Thromb and Hemost.* 14, 66, 1988.
- Bastida E, Escolar G, Ordinas A, Jamieson GA. : Morphometric evaluation of thrombogenesis by microvesicles from human tumor cell lines with thrombin-dependent (UM87MG) and adenosine diphosphate-dependent (SKNMC) platelet activation mechanisms. *J Clin Invest.* 108, 622, 1986.
- Bastida E, Ordinas A, Jamieson GA. : Differing platelet aggregation effects by tumor cell lines: Absence of role for platelet derived ADP. *Am J Hematol.* 11, 367, 1981.
- Bastida E, Ordinas A, Escolar G, Jamieson GA. : Tissue factor in microvesicles shed from U87MG human glioblastoma cells induce coagulation, platelet aggregation and thrombogenesis. *Blood.* 64, 177, 1984.

Bastida E, del Prado J, Almirall L, Jamieson GA, Ordinas A. : Inhibitory effect of dipyridamole on growth, nucleoside incorporation and platelet-activating capability in the U87MG and SKNMC human tumor cell lines. *Cancer Res.* 45, 4048, 1985.

Baumgartner HR. : The role of blood flow in platelet adhesion, fibrin deposition and formation of mural thrombi. *Microvasc Res.* 5, 167, 1973.

Bennett JS, Vilaire G. : Exposure of platelet fibrinogen receptors by ADP and epinephrine. *J Clin Invest.* 64, 1393, 1979.

Berndt MC, Caen JP. : Platelet glycoproteins. In Spaet TH (ed) *Progress in Hemostasis and Thrombosis*, Vol 7, New York, Grune and Stratton. 111, 1984.

Berndt MC, Gregory C, Chon BH, Zola H, Castaldi PA. : Additional glycoprotein defects in Bernard-Soulier's Syndrome: Confirmation of genetic basis by parental analysis. *Blood.* 62, 800, 1983.

Berndt MC, Phillips DR. : Interaction of thrombin with platelets: Purification of the thrombin substrate. *Ann NY Acad Sci.* 370, 87, 1981.

Bienz D, Schnippering W, Clemetson KJ. : Glycoprotein V is not the thrombin activation receptor on human blood platelets. *Blood.* 68, 720, 1986.

Billroth T. : *Lectures on Surgical Pathology and Therapeutics* (Translated from the 8th. edition) - The New Sydenham Society, London. 355, 1878.

Brinkhous KM, Read MS, Mason RG. : Plasma thrombocyte-agglutinating activity and fibrinogen: Synergism with adenosine diphosphate. *Lab Invest.* 14, 335, 1965.

Brown JC, Goodman SL. : Different cellular receptors for human placental laminin and murine EHS laminin. *FEBS Lett.* 282, 5, 1991.

Burtin P, Chavenel G, Foidart JM, Martin E. : Antigens of the basement membrane and the peritumoral stroma in human colon adenocarcinomas: An immunofluorescence study. *Int J Cancer.* 30, 13, 1982.

Caen J, Castaldi PA, Leclerc JC, Inceman S, Larrieu ML, Probst M, Bernard J. : Congenital bleeding disorders with long bleeding time and normal platelet count. *Am J Med.* 41, 4, 1966.

Carrel NA, Fitzgerald LA, Steiner B, Erickson HP, Phillips DR. : Structure of human platelet membrane Glycoprotein IIb and IIIa as determined by electron microscopy. J Biol Chem. 260, 1743, 1985.

Cazenave J-P, Packham MA, Kinlough-Rathbone RL, Mustard JF. : Platelet adherence to the vessel wall and to collagen-coated surfaces. Adv Exp Med Biol. 102, 31, 1978.

Cazenave J-P, Blondowska D, Richardson M, Kinlough-rathbone RL, Packham MA, Mustard JF. : Quantitative radioisotopic measurement and scanning electron microscopic study of platelet adherence to a collagen-coated surface and to subendothelium with a rotating probe device. J Lab Clin Med. 93, 60, 1979.

Chen J, Ishii M, Wang L, Ishii K, Coughlin SR. : Thrombin receptor activation: Confirmation of the intramolecular tethered hypothesis and discovery of an alternative intermolecular liganding mode. J Biol Chem. 269, 16041, 1994.

Cheresh DA, Spiro RC. Biosynthetic and functional properties of an Arg-Gly-Asp-directed receptor involved in human melanoma cell attachment to vitronectin, fibrinogen, and von Willebrand factor. J Biol Chem. 262, 17703, 1987.

Chew EC, Josephson RL, Wallace AL. : Morphologic aspects of the arrest of circulating cancer cells. In Fundamental Aspects of Metastasis, L Weiss (ed), North Holland, Amsterdam. 121, 1976.

Chong BH, Berndt MC, Koutts J, Castaldi PA : Quinidine-induced thrombocytopenia and leukopenia: Demonstration and characterization of distinct antiplatelet and antileukocyte antibodies. Blood. 62, 1218, 1983.

Cioce V, Margulies IM, Sobel ME, Castronovo V. : Interaction between the 67 kilodalton metastasis-associated laminin receptor and laminin. Kidney International. 43, 30, 1993.

Coller BS, Peerschke EI, Scudder LE, Sullivan CA. : Studies with a murine monoclonal antibody that abolishes Ristocetin induced binding of von Willebrand factor to platelets: Additional evidence in support of GPIb as a platelet receptor for von Willebrand factor. Blood. 61, 99, 1983.

Coller BS. : Activation affects access to the platelet receptor for adhesive glycoproteins. J Cell Biol. 103, 451, 1986.

Coller BS, Beer JH, Scudder LE, Steinberg MH. : Collagen-platelet Interactions: Evidence for a direct interaction of collagen with platelet GPIa/IIa and an indirect interaction with platelet GPIIb/IIIa mediated by adhesive proteins. Blood. 74, 182, 1989.

Cooper AR, Kurkinen M, Taylor A, Hogan BLM. : Studies on the biosynthesis of laminin by murine parietal endoderm cells. Eur J Biochem. 119, 189, 1981.

Cooper HA, Bennet WP, White GC II, Wagner RH. : Hydrolysis of human platelet membrane glycoproteins with a *Serratia marcescens* metalloprotease: Effect on response to Thrombin and von Willebrand factor. Pro Natl Acad Sci (USA). 79, 1433, 1982.

Cowan DH, Robertson AL, Shook P, Giroski P. : Platelet adherence to collagen: Role of plasma, ADP and divalent cations. Br J Haematol. 47, 257, 1981.

Crissman JD, Hatfield J, Schaldenbrand M, Sloane BF, Honn KV. : Arrest and extravasation of B16 amelanotic melanoma in murine lungs. A light and electron microscopic study. Lab Invest. 53, 470, 1985.

Crissman JD, Hatfield JS, Menter DG, Sloane BF, Honn KV. : Morphologic study of the interaction of intravascular tumor cells with endothelial cells and subendothelial matrix. Cancer Res. 48, 4065, 1988.

Curatolo L, Colucci M, Cambini AL, Poggia A, Morasca L, Donati MB, Semeraro N : Evidence that cells from experimental tumours can activate coagulation factor X. Br J Cancer. 40, 228, 1979.

Engel J, Odermatt E, Engel A, Madri JA, Furthmayr H, Rohde H, Timpl R. : Shapes, domain organization and flexibility of laminin and fibronectin, two multifunctional proteins of the extracellular matrix. J Mol Biol. 150, 97, 1981.

Engvall E, Davis GE, Dickerson K, Ruoslahti E, Varon S, Manthorpe M. : Mapping of domains in human laminin using monoclonal antibodies: Localization of the neurite-promoting site. J Cell Biol. 103, 2457, 1986.

Fenton JW, Fasco MJ, Stackrow AB, Aronson DL, Young AM, Finlayson JS. : Human thrombins: Production, evaluation and properties of alpha thrombin. J Biol Chem. 252, 3587, 1977.

Fidler IJ. : The relationship of embolic homogeneity, number, size and viability to the incidence of experimental metastasis. Eur J of Cancer. 9, 223, 1973.

Fox JEB, Aggerbeck LA, Berndt MC. : Structure of the Glycoprotein Ib-IX complex from platelet membranes. *J Biol Chem.* 263, 4882, 1988.

Fujimoto T, Ohara S, Hawiger J. : Thrombin-induced exposure and prostacyclin inhibition of the receptor for factor VIII/von Willebrand factor on human platelets. *J Clin Invest.* 69, 1212, 1982.

Ganguly P, Gould NL. : Thrombin receptors of human platelets: Thrombin binding and anti-thrombin properties of Glycoprotein I. *Br J Haematol.* 42, 137, 1979.

Gasic GJ, Gasic TB. : Removal of sialic acid from the cell coat in tumor cells and vascular endothelium and its effects on metastasis. *Proc Natl Acad Sci (USA).* 48, 1172, 1962.

Gasic GJ, Gasic TB, Galanti N, Johnson T, Murphy S. : Platelet-tumor cell interaction in mice. The role of platelets in the spread of malignant disease. *Int J Cancer.* 11, 704, 1973.

Gasic GJ, Gasic TB, Stewart GC. : Anti-metastatic effects associated with platelet reduction. *Proc Natl Acad Sci (USA).* 61, 46, 1968.

Gehlsen KR, Dillner L, Engvall E, Ruoslahti E. : The human laminin receptor is a member of the integrin family of cell adhesion receptors. *Science,* 241, 1228, 1988.

Ginsberg MH, Forsyth J, Lightsey A, Chediak J, Plow EF. : Reduced surface expression and binding of fibronectin by thrombin-stimulated thrombasthenic platelets. *J Clin Invest.* 71, 619, 1983.

Ginsberg MH, Loftus JC, Plow EF. : Cytoadhesins, Integrins and platelets. *Thromb Hemost.* 59, 1, 1988.

Ginsberg MH, Loftus J, Ryckwaert J-J, Pierschbacher M, Pytela R, Rouschlahti E, Plow EF : Immunochemical and amino-terminal sequence comparison of two cytoadhesins indicates that they contain similar or identical beta subunits and distinct alpha subunits. *J Biol Chem.* 262, 5437, 1987.

Gogstad GO, Hagen I, Krutnes MB, Solum NO : Disassociation of the glycoprotein IIb/IIIa complex in isolated human platelet membranes: Dependence of pH and divalent cations. *Biochem Biophys Acta.* 689, 21, 1982.

Goodman S. : Alpha6/beta1 integrin and laminin E8: An increasingly complex simple story. *Kidney International,* 41, 650, 1992.

Gordon SG, Franks JJ, Lewis J. : Comparison of procoagulant activities in extracts of normal and malignant human tissue. *J Nat Cancer Inst.* 62, 773, 1979.

Graf J, Iwamoto Y, Sasaki M, Martin GR, Kleinman HK, Robey FA, Yamada Y. : Identification of an amino acid sequence in laminin mediating cell attachment, chemotaxis and receptor binding. *Cell.* 48, 989, 1987.

Greco NJ, Jamieson GA. : High and moderate affinity pathways for alpha-thrombin-induced platelet activation. *Proc Soc Exp Biol Med.* 198, 792, 1991.

Greenberg JP, Packham MA, Guccione MA, Rand ML, Reimers HJ, Mustard JF. : Survival of rabbit platelets treated in vitro with chymotrypsin, plasmin, trypsin or neuraminidase. *Blood.* 53, 916, 1979a.

Greenberg JP, Packham MA, Guccione MA, Harfenist EJ, Orr JL, Kinlough-Rathbone RL, Perry DW, Mustard JF. : The effect of pre-treatment of human or rabbit platelets with chymotrypsin on their responses to human fibrinogen and aggregating agents. *Blood.* 54, 753, 1979b.

Grotendorst GR, Seppa HEJ, Kleinman HK, Martin GR. : Attachment of smooth muscle cells to collagen and their migration toward platelet-derived growth factor. *Proc Natl Acad Sci USA.* 78, 3669, 1981.

Haaparanta T, Uitto J, Ruoslahti E, Engvall E. : Molecular cloning of cDNA encoding human laminin A chain. *Matrix.* 11, 151, 1991.

Hadley MA, Byers SW, Suarez-Quian CA, Kleinman HK, Dym M. : Extracellular matrix regulates Sertoli cell differentiation, testicular cord formation and germ cell development in vitro. *J Cell Biol.* 101, 1511, 1985.

Hagen I, Nurden A, Bjerrum OJ, Solum NO, Caen J. : Immunochemical evidence for protein abnormalities in platelets from patients with Glanzmann's thrombasthenia and Bernard-Soulier syndrome. *J Clin Invest.* 65, 722, 1980.

Hanna N. : Role of natural killer cells in control of cancer metastasis. *Cancer Metast Rev.* 1, 45, 1982.

Harmon JT, Jamieson GA. : Activation of platelets by alpha thrombin is a receptor-mediated event. *J Biochem.* 261, 15928, 1986.

Harmon JT, Jamieson GA. : Platelet activation by thrombin in the absence of the high-affinity thrombin receptor. *Biochem.* 27, 2151, 1988.

Hawiger J, Parkinson S, Timmons S. : Prostacyclin inhibits mobilisation of fibrinogen-binding sites on human ADP- and thrombin- treated platelets. *Nature*. 283, 195, 1980.

Hawrylowicz CM, Howells GL, Feldman M. : Platelet-derived interleukin 1 induces human endothelial adhesion molecule expression and cytokine production. *J Exp Med*. 174, 785, 1991.

Hemler ME. : VLA proteins in the integrin family: Structures, functions and their role on leukocytes. *Ann Rev Immunol*. 8, 365, 1990.

Hemler ME, Crouse C, Takada Y, Sonnenberg A. : Multiple very late antigen (VLA) heterodimers on platelets: Evidence for VLA-2, VLA-5 (fibronectin receptor) and VLA-6 structures. *J Biol Chem*. 263, 7660, 1988.

Holme R, Oftebro R, Hovig T. : In vitro interaction between cultured cells and human blood platelets. *Thrombos Haemostas*. 40, 89, 1978.

Holmsen H, Day HJ, Stormorken H. : The blood platelet release reaction. *Scand J Haematol. Suppl*, 8, 3, 1969.

Honn KV, Busse WD, Sloane BF. : Prostacyclin and thromboxanes. Implications for their role in tumor cell metastasis. *Biochem Pharmacol*. 32, 1, 1983.

Hsu-Lin S-C, Berman CL, Furie BC, August D, Furie B. : A platelet membrane protein expressed during platelet activation and secretion. *J Biol Chem*. 259, 9121, 1984.

Hovig T. : The effect of calcium and magnesium on rabbit blood platelet aggregation in vitro. *Thrombosis et Diathesis Haemorrhagica*, 12, 179, 1964.

Huang TW, Benditt EP. : Mechanisms of platelet adhesion to the basal lamina. *Am J Pathol*. 92, 99, 1978.

Huard TK, Malinoff HL, Wicha MS. : Macrophages express a plasma membrane receptor for basement membrane laminin. *Am J Pathol*. 123, 365, 1986.

Hynes RO. : Integrins: A family of cell surface receptors. *Cell*. 48, 549, 1987.

Ibele GM, Kay NE, Johnson GJ, Jacob HS. : Human platelets exert cytotoxic effects on tumour cells. *Blood*. 65, 12521, 1985.

Ill CR, Engvall E, Ruoslahti E. : Adhesion of platelets to laminin in the absence of activation. *J Cell Biol*. 99, 2140, 1984.

Iwamoto Y, Robey F, Graf J, Sasaki M, Kleinman HK, Yamada Y, Martin GR. : YIGSR, a synthetic laminin pentapeptide, inhibits experimental metastasis formation. *Science*. 238, 1132, 1987.

Jamieson GA, Bastida E, Ordinas A. : Interaction of platelets with tumor cells. In Mcyntire DE, Gordon JL (eds): *Platelets in biology and pathology*, Elsevier, North Holland, Amsterdam. 161, 1987.

Jenkins CSP, Philips DR, Clemetson KJ, Meyer D, Larrieu MJ, Luscher EF. : Platelet membrane glycoproteins implicated in ristocetin induced aggregation. Studies of the proteins on platelets from patients with Bernard-Soulier Syndrome and von Willebrand's Disease. *J Clin Invest*. 57, 112, 1976.

Johnson GI, Cook RR, McEver RP. : Cloning of GMP140, a granule membrane protein of platelets and endothelium: Sequence similarity to proteins involved in cell adhesion and inflammation. *Cell*, 56, 1033, 1989.

Jones DS, Wallace AC, Fraser EE. : Sequence of events in experimental metastases of Walker 256 tumor: Light, immunofluorescent and electron microscopic observations. *J Nat Cancer Inst*. 46, 493, 1971.

Kao KJ, Pizzo SV, McKee PA. : Demonstration and characterization of specific binding sites for Factor VIII/von Willebrand factor on human platelets. *J Clin Invest*. 63, 656, 1979.

Karas SP, Rosse WF, Kurlander RJ. : Characterization of the IgG-F_C receptor on human platelets. *Blood*. 60, 1277, 1982.

Kleinman HK, Cannon FB, Laurie GW, Hassell JR, Aumailley M, Terranova VP, Martin GR, DuBois-Dalcq M. : Biological activities of laminin. *J Cell Biochem*. 27, 317, 1985.

Kleinman HK, Weeks BS, Schnaper HW, Kibbey MC, Yamamura K, Grant DS. : The laminins: A family of basement membrane glycoproteins important in cell differentiation and tumor metastases. *Vitamins and hormones*. 47, 161, 1993.

Kramer RH, Nicolson GL. : Interaction of tumor cells with vascular endothelial cell monolayers: A model for metastatic invasion. *Proc Nat Acad Sci (USA)*. 76, 5704, 1979.

Kunicki TJ, Johnson MA, Aster RH. : Absence of the platelet receptor for drug-dependent antibodies in the Bernard-Soulier Syndrome. *J Clin Invest*. 62, 716, 1978.

Kunicki TJ, Nugent DJ, Staats SJ, Orchekowski RP, Wayner EA, Carter WG. : The human fibroblast class II extracellular matrix receptor mediates platelet adhesion to collagen and is identical to the platelet glycoprotein Ia/IIa complex. *J Biol Chem* 263, 4516, 1988.

Lam SC, Plow EF, D'Souza SE, Cheresh DA, Frelinger AL III, Ginsberg MH. : Isolation and characterization of a platelet membrane protein related to the vitronectin receptor. *J Biol Chem.* 264, 3742, 1989.

Lapis K, Paku S, Liotta LA. : Endothelialization of embolized tumor cells during metastasis formation. *Clin Exp Metastasis.* 6, 73, 1988.

Lawler J, Hynes RO. : The structure of human thrombospondin, an adhesive glycoprotein with multiple calcium-binding sites and homologies with several different proteins. *J Cell Biol.* 103, 1635, 1986.

Lawler J, Hynes RO. : An integrin receptor on normal and thrombasthenic platelets that binds thrombospondin. *Blood.* 74, 202, 1989.

Lesot H, Kuhl U, von der Mark K. : Isolation of a laminin-binding protein from muscle cell membranes. *EMBO J.* 2, 861, 1983.

Liotta LA. : Tumor invasion and metastases - Role of the extracellular matrix: Rhoads Memorial Award Lecture. *Cancer Res.* 46, 1, 1986.

Liotta LA, Kleinerman J, Catanzaro P, Rynbrandt D. : Degradation of basement membrane by murine tumor cells. *J Nat Cancer Inst.* 58, 1427, 1977.

Liotta LA, Rao NC, Wewer UM. : Biochemical interactions of tumor cells with the basement membrane. *Ann Rev Biochem.* 55, 1037, 1986.

Leyrly D, Kreger A. : Purification and characterization of a *Serratia marcescens* metalloprotease. *Infection and Immunity.* 24, 411, 1979.

Malinoff H, Wicha MS. : Isolation of a cell surface receptor protein for laminin from murine fibrosarcoma cells. *J Cell Biol.* 96, 1475, 1983.

Marguerie Ga, Plow EF, Edgington TS. : Human platelets possess an inducible and saturable receptor specific for fibrinogen. *J Biol Chem.* 254, 5357, 1979.

Martin GR, Timpl R. : Laminin and other basement membrane components. *Ann Rev Cell Biol.* 3, 57, 1987.

- McCarthy JB, Palm SL, Furcht LT. : Migration by haptotaxis of a Schwann cell tumor line to the basement membrane glycoprotein laminin. *J Cell Biol.* 97, 772, 1983.
- McEver RP, Bennet EM, Martin MN. : Identification of two structurally and functionally distinct sites on human platelet membrane glycoprotein IIb-IIIa using monoclonal antibodies. *J Biol Chem.* 258, 5269, 1983.
- McGowan EB, Detwiler TC. : Modified platelet responses to thrombin. Evidence for two types of receptors or coupling mechanisms. *J Biol Chem.* 261, 739, 1986.
- Mecham RP. : Receptors for laminin on mammalian cells. *FASEB J.* 5, 2538, 1991
- Menter DG, Steinert BW, Sloane BF, Gundlach N, O'Gara CY, Marnett LJ, Diglio C, Walz D, Taylor JD, Honn KV. : Role of platelet membrane in enhancement of tumor cell adhesion to endothelial cell extracellular matrix. *Cancer Res.* 47, 6751, 1987.
- Mercurio AM, Shaw LM. : Macrophage interactions with laminin: PMA selectively induces the adherence and spreading of mouse macrophages on a laminin substratum. *J Cell Biol.* 107, 1873, 1988.
- Meyer D, Baumgartner HR. : Role of von Willebrand factor in platelet adhesion to the subendothelium. *Br J Haematol.* 54, 1, 1983.
- Michelson AD, Barnard MR. : Thrombin-induced changes in platelet membrane Glycoprotein Ib, IX and IIb-IIIa complex. *Blood.* 70, 1673, 1987.
- Mustard JF, Packham MA, Kinlough-Rathbone RL, Perry DW, Regoeczi E. : Fibrinogen and ADP-induced platelet aggregation. *Blood.* 52, 453, 1978.
- Nachman RL. : The platelet as an inflammatory cell. In *Platelets: A multidisciplinary approach.* Edited by G de Goetano and S Garattini. Raven Press, New York. 119, 1978.
- Nachman RL, Leung LLK. : Complex formation of platelet membrane glycoproteins IIb and IIIa with fibrinogen. *J Clin Invest.* 69, 263, 1982.
- Nakajima M, Irimura T, Di Ferrante D, Di Ferrante N, Nicolson GL. : Heparan sulfate degradation: Relation to tumor invasive and metastatic properties of mouse B16 melanoma sublines. *Science.* 220, 611, 1983.

Newman PJ, Berndt MC, Gorski J, White GC II, Lyman S, Paddock C, Muller WA. : PECAM-1 (CD31) cloning and relation to adhesion molecules of the immunoglobulin gene superfamily. *Science*. 247, 1219, 1990

Newman PJ, Derbes RS, Aster RH. : The human platelet alloantigens Pl^{A1} and Pl^{A2} are associated with a leucine³³/proline³³ amino acid polymorphism in membrane glycoprotein IIIa, and are distinguishable by DNA typing. *J Clin Invest*. 83, 1778, 1989.

Nicolson GL. : Cell surfaces and blood-borne tumor metastasis. *Progress in Cancer Research and Therapy*. 5, 163, 1977.

Nieuwenhuis HK, Akkerman JWN, Houdijk WPM, Sixma JJ. : Human blood platelets showing no response to collagen fail to express surface glycoprotein Ia. *Nature*. 318, 470, 1985.

Nieuwenhuis HK, Sakariassen KS, Houdijk WPM, Nievelstein PFEM, Sixma JJ. : Deficiency of platelet membrane Glycoprotein Ia associated with a decreased platelet adhesion to subendothelium: A defect in platelet spreading. *Blood*. 68, 692, 1986.

Niewiarowski S, Budzynski AZ, Morinelli TA, Brudzynski TM, Steward GJ. : Exposure of fibrinogen receptor on human platelets by proteolytic enzymes. *J Biol Chem*. 256, 917, 1981.

Niewiarowski S, Kornecki E, Hershock D, Tuszyński GP, Bennett JS, Soria C, Soria J, Dunn F, Pidadar D, Keiffer N, Nurden AT. : Aggregation of chymotrypsin-treated thrombasthenic platelets is mediated by fibrinogen binding to glycoproteins IIb and IIIa. *J Lab Clin Med*. 106, 651, 1985.

Nissinen M, Vuolteenaho R, Boot-Handford R, Kallunki P, Tryggvason K. : Primary structure of the human laminin A chain - Limited expression in human tissue. *Biochem J*. 276, 369, 1991.

Okumura T, Jamieson GA. : Platelet Glycocalicin I. Orientation of glycoproteins of the human platelet surface. *J Biol Chem*. 251, 5944, 1976.

Okumura T, Lombart C, Jamieson GA. : Platelet glycocalicin II. Purification and characterization. *J Biol Chem*. 251, 5950, 1976.

Oldberg A, Heldin C-H, Wasteson A, Busch C, Hook M. : Characterization of a platelet endoglycosidase degrading heparin-like polysaccharides. *Biochemistry*. 19, 5755, 1980.

Ordinas A, Diaz-Ricart M, Bastida E, Escolar G, Castillo R, Tandon NN, Jamieson GA. : The role of subendothelial laminin and platelet laminin receptors in haemostasis. *Nouvelle Revue Francaise D'Hematologie*. 34,1, 61, 1992.

Paul D, Niewiarowski S, Varma KG, Rucinski B, Rucker S, Lange E. : Human platelet basic protein associated with antiheparin and mitogenic activities: Purification and partial characterization. *Proc Natl Acad Sci USA*. 77, 5914, 1980.

Paulsson M, Deutzmann R, Dziadek M, Nowack H, Timpl R, Weber S, Engel J. : Purification and structural characterization of intact and fragmented nidogen obtained from a tumor basement membrane. *Eur J Biochem*. 156, 467, 1986.

Paulsson M, Aumailley M, Deutzmann R, Timpl R, Beck K, Engel J. : Laminin-nidogen complex extraction with chelating agents and structural characterisation. *Eur J Biochem*. 166, 11, 1987.

Paulsson M, Saladin K. : Mouse heart laminin. *J Biol Chem*. 264, 18726, 1989.

Pearlstein E, Ambrogio C, Karpatkin S. : Effect of antiplatelet antibody on the development of pulmonary metastasis following injection of CT26 colon adenocarcinoma Lewis lung carcinoma and B16 amelanotic melanoma tumor cells into mice. *Cancer Res*. 44, 3884, 1984.

Peerschke EIB. : The platelet fibrinogen receptor. *Sem Hematol*. 22, 241-259, 1985.

Peerschke EIB, Collier BS. : A murine monoclonal antibody that blocks fibrinogen binding to normal platelets also inhibits fibrinogen interactions with chymotrypsin-treated platelets. *Blood*. 64, 59, 1984.

Peerschke EI, Zucker MB, Grant RA, Egan JJ, Johnson MM. : Correlation between fibrinogen binding to human platelets and platelet aggregability. *Blood*. 55, 841, 1980.

Pepper DS, Jamieson GA. : Studies on Glycoproteins III: Isolation of sialylglycopeptides from human platelet membranes. *Biochem*. 8, 3362, 1969.

Phillips DR, Agin PP. : Platelet plasma membrane glycoproteins: Evidence for the presence of non equivalent disulfide bonds using nonreduced-reduced two-dimensional gel electrophoresis. *J Biol Chem*. 252, 2121, 1977a.

Phillips DR, Agin FP. : Platelet membrane defects in Glanzmann's thrombasthenia. Evidence for decreased amounts of two major glycoproteins. *J Clin Invest*. 60, 535, 1977b.

- Pikkarainen T, Eddy R, Fukushima Y, Byers M, Shows T, Pihlajaniemi T, Sarasta M, Tryggvason K. : Human laminin B1 chain. *J Biol Chem.* 262, 10454, 1987.
- Pikkarainen T, Kallunki T, Tryggvason K. : Human laminin B2 chain. *J Biol Chem.* 263, 6751, 1988.
- Pietu G, Cherel G, Marguerie G, Meyer D. : Inhibition of von Willebrand factor-platelet interaction. *Nature.* 308, 648, 1984.
- Piotrowicz RS, Orzechowski RP, Nugent DJ, Yamada KY, Kunicki TJ. : Glycoprotein Ic-IIa functions as an activation-independent fibronectin receptor on human platelets. *J Cell Biol.* 106, 1359, 1988.
- Pischel KD, Bluestein HG, Woods VL.Jr. : Platelet glycoproteins Ia, Ic and IIa are physicochemically indistinguishable from the Very Late Activation Antigens adhesion-related proteins of lymphocytes and other cell types. *J Clin Invest.* 81, 505, 1988.
- Plow EF, Ginsberg MH. : Specific and saturable binding of plasma fibronectin to thrombin-stimulated human platelets. *J Biol Chem.* 256, 9477, 1981.
- Plow EF, Marguerie GA, Ginsberg MH. : Fibronectin binding to thrombin-stimulated platelets: Evidence for fibrin(ogen) independent and dependent pathways. *Blood.* 66, 26, 1985.
- Podolsak B. : Effects of thrombin, chymotrypsin and aggregated gamma-globulin on the proteins of the human platelet membrane. *Thrombos. Haemostas.* 37, 396, 1977.
- Poncz M, Eisman R, Heidenreich R, Silver SM, Vilaire G, Surrey S, Schartz E, Bennet JS. : Structure of the platelet membrane glycoprotein IIb. *J Biol Chem* 262, 8476, 1987.
- Poste G, Fidler IJ. : The pathogenesis of cancer metastasis. *Nature.* 283, 139, 1980.
- Pytela R, Pierschbacher MD, Ginsberg MH, Plow EF, Ruoslahti E. : Platelet membrane glycoprotein IIb/IIIa: Member of a family of Arg-Gly-Asp-specific adhesion receptors. *Science.* 231, 1559, 1986.
- Rao CN, Margulies IMK, Tralka TS, Terranova VP, Madri JA, Liotta LA. : Isolation of a subunit of laminin and its role in molecular structure and tumor cell attachment. *J Biol Chem.* 257, 9740, 1982.
- Rao CN, Barsky SH, Terranova VP, Liotta LA. : Isolation of a tumor cell laminin receptor. *Biochem Biophys Res Commun.* 111, 804, 1983.

Rice EG, Bevilacqua MP. : An inducible endothelial cell surface glycoprotein mediates melanoma adhesion. *Science*. 246, 1303, 1989.

Rouslahti E, Pierschbacher MD. : New perspectives in cell adhesion:RGD and integrins. *Science*. 238, 491, 1987.

Ruggeri ZM, Bader R, De Marco L. : Glanzmann thrombasthenia: Deficient binding of von Willebrands factor to thrombin-stimulated platelets. *Proc Natl Acad Sci USA*. 79, 6038, 1982.

Ruggeri ZM, DeMarco L, Gatti L, Bader R, Montgomery RR. : Platelets have more than one binding site for von Willebrand factor. *J Clin Invest*. 72, 1, 1983.

Ruggeri ZM, Zimmerman TS. : Platelets and von Willebrand Disease. *Sem in Hematol*. 22, 203, 1985.

Saiki I, Murata J, Iida J, Sakurai T, Nishi N, Matsuno K, Azuma I.: Antimetastatic effects of synthetic polypeptides containing repeated structures of the cell adhesive Arg-Gly-Asp (RGD) and Tyr-Ile-Gly-Ser-Arg (YIGSR) sequences. *BR J Cancer*, 60, 722, 1989.

Santoro SA. : Identification of a 160,000 dalton platelet membrane protein that mediates the initial divalent cation-dependent adhesion of platelets to collagen. *Cell*. 46, 913, 1986.

Santoro SA, Cunningham LW. : Fibronectin and the multiple interaction model for platelet-collagen adhesion. *Proc Natl Acad Sci (USA)*. 76, 2644, 1979.

Santoro SA, Walsh JJ, Staatz WD, Baranski KJ. : Distinct determinants on collagen support α_2/β_1 integrin-mediated platelet adhesion and platelet activation. *Cell Regulation*. 2, 905, 1991.

Sasaki M, Kato S, Kohno K, Martin GR, Yamada Y. : Sequence of cDNA encoding the laminin B1 chain reveals a multidomain protein containing cysteine-rich repeats. *Proc Natl Acad Sci (USA)*. 84, 935, 1987.

Sasaki M, Kleinman HK, Huber H, Deutzmann R, Yamada Y. : Laminin, a multidomain protein. The A chain has a unique globular domain and homology with the basement membrane proteoglycan and the laminin B chains. *J Biol Chem*. 263, 16536, 1988.

Schullek J, Jordan J, Montgomery RR. : Interaction of von Willebrand factor with human platelets in the plasma milieu. *J Clin Invest*. 73, 421, 1984.

- Shadle PJ, Barondes SH. : Adhesion of human platelets to immobilized trimeric collagen. *J Cell Biol.* 95, 361, 1982.
- Simionescu N, Simionescu M, Palade G. : Open junctions in the endothelium of the postcapillary venules of the diaphragm. *J Cell Biology.* 79, 27, 1978.
- Sindelar WF, Tralka TS, Ketcham AS. : Electron microscopic observations on formation of pulmonary metastases. *J Surg Res.* 18, 137, 1975.
- Skolnik G, Bagge U, Dahlstrom A, Ahlman H. : The importance of 5HT for tumor cell lodgement. *Int J Cancer.* 33, 519, 1984.
- Solum NO. : Platelet membrane proteins. *Sem in Hematol.* 22, 289, 1985.
- Solum NO, Hagen I, Fillion-Myklienbust C, Stabaek T. : Platelet glycoprotein: its membrane association and solubilization in aqueous media. *Biochimica Biophysica Acta.* 597, 235, 1980.
- Sonnenberg A, Modderman PW, Hogervorst F. : Laminin receptor on platelets is the Integrin VLA-6. *Nature.* 336, 487, 1988.
- Sonnenberg A, Gehlsen KR, Aumailley M, Timpl R. : Isolation of α_6/β_1 integrins from platelets and adherent cells by affinity chromatography on mouse laminin fragment E8 and human pepsin laminin fragment. *Exper Cell Res.* 197, 234, 1991.
- Staatz WD, Rajpara SM, Wayner EA, Carter WG, Santoro SA. : The membrane glycoprotein Ia-IIa (VLA-2) complex mediates the Mg^{++} -dependent adhesion of platelets to collagen. *J Cell Biol.* 108, 1917, 1989.
- Stenberg PE, McEver RP, Shuman MA, Jacques YV, Bainton DF. : A platelet alpha-granule membrane protein (GMP-140 is expressed on the plasma membrane after activation). *J Cell Biol.* 101, 880, 1985.
- Takada Y, Hemler ME. : The primary structure of the VLA-2/collagen receptor α_2 subunit (platelet GPIa): Homology to other integrins and the presence of a possible collagen-binding domain. *J Cell Biol.* 109, 397, 1989.
- Takada Y, Huang C, Hemler ME. : Fibronectin receptor structures in the VLA family of heterodimers. *Nature.* 326, 607, 1987.

- Takahashi N, Takahashi Y, Putman FW. : Periodicity of leucine and tandem repetition of a 24 amino acid segment in the primary structure of leucine-rich alpha₂-glycoprotein of human serum. Proc Natl Acad Sci (USA). 82, 1906, 1985.
- Tam SW, Fenton JW II, Detwiler TC. : Platelet thrombin receptors. J Biol Chem. 255, 6626, 1980.
- Tandon NN, Holland EA, Kralisz U, Kleinman HK, Robey FA, Jamieson GA. : Interaction of human platelets with laminin and identification of the 67kDa laminin receptor on platelets. Biochemical Journal. 274, 2, 535, 1991.
- Tandon NN, Lipsky RH, Burgess WH, Jamieson, GA. : Isolation and characterisation of platelet glycoprotein IV (CD36) J Biol Chem, 264, 7570, 1989a
- Tandon NN, Kralisz U, Jamieson GA. : Identification of Glycoprotein IV (CD36) as a primary receptor for platelet-collagen adhesion. J Biol Chem. 264, 7576, 1989b.
- Terranova VP, Rao CN, Kalebic T, Margulies IM, Liotta LA. : Laminin receptor on human breast carcinoma cells. Proc Natl Acad Sci (USA). 80, 444, 1983.
- Timpl R, Rohde H, Robey PG, Rennard SI, Foidart JM, Martin GR. : Laminin - A glycoprotein from basement membranes. J Biol Chem. 254, 9933, 1979.
- Timpl R, Dziadek M, Fujiwara S, Nowack H, Wick G. : Nidogen: A new self-aggregating basement membrane protein. Eur J Biochem. 137, 455, 1983.
- Tobias JW, Bern MM, Netland PA, Zetter BR. : Monocyte adhesion to subendothelial components. Blood. 69, 1265, 1987.
- Tohgo A, Tanaka NG, Osada Y. : Inhibitory effects of DN-9693 on platelet-enhanced tumor cell attachment to cultured endothelium, Invasion Metastasis. 10, 1, 1990.
- Tollefsen DM, Majerus PW. : Inhibition of human platelet aggregation by monovalent antifibrinogen antibody fragments. J Clin Invest. 55, 1259, 1975.
- Tschopp TB, Weiss HJ, Baumgartner HR. : Decreased adhesion of platelets to subendothelium in von Willebrand's Disease. J Lab Clin Med. 83, 296, 1974.
- Tuszynski GP, Daniel JL, Stewart G. : Association of proteins with the platelet cytoskeleton. Sem Hematol. 22, 303, 1985.

Vu T-KH, Hheaton VI, Hung DT, Charo I, Coughlin SR. : Domains specifying thrombin-receptor interaction. *Nature*. 353, 674, 1991.

Warren BA, Vales O. : The adhesion of thromboplastic tumour emboli to vessel walls in vivo. *Br J Exp Path*. 53, 301, 1972.

Wayner EA, Carter WG, Piotrowicz RS, Kunicki TJ. : The function of multiple extracellular matrix receptors in mediating cell adhesion to extracellular matrix: Preparation of monoclonal antibodies to the fibronectin receptor that specifically inhibit cell adhesion to fibronectin and react with platelet glycoproteins Ic-IIa. *J Cell Biol*. 107: 1881, 1988.

Wewer UM, Liotta LA, Jaye M, Jaye M, Ricca GA, Drohan WN, Claysmith AP, Rao CN, Wirth P, Coligan JE, Albrechtsen R, Mudryj M, Sobel ME. : Altered levels of laminin receptor mRNA in various human carcinoma cell that have different abilities to bind laminin. *Proc Natl Acad Sci (USA)*. 83, 7137, 1986.

Williams AF, Barclay AN. : The immunoglobulin superfamily-domains for cell surface recognition. *Ann Rev Immunol*. 6, 381, 1988.

Wolff R, Plow EF, Ginsberg MH. : Interaction of thrombospondin with resting and stimulated human platelets. *J Biol Chem*. 261, 6840, 1986.

Wood S. : Pathogenesis of metastasis formation observed in vivo in the rabbit ear chamber. *Arch Pathol*. 66, 550, 1958.

Wright SD, Reddy PA, Jong MTC, Erickson BW. : C₃bi receptor (complement receptor type 3) recognizes a region of complement protein C₃ containing the sequence Arg-Gly-Asp. *Pro Natl Acad Sci (USA)*. 84 1965, 1987.

Yamamoto N, Greco NJ, Barnard MR, Tanoue K, Yamakazi H, Jamieson GA, Michelson AD : GPIIb-dependent and GPIIb-independent pathways of thrombin-induced platelet activation. *Blood*. 77, 1740, 1991.

Zarcharski LR. : Rationale for anticoagulant treatment of cancer. In Honn KV, Sloane BF (eds): *Hemostatic mechanisms and metastasis*. Martinus Nijhoff, Boston. 375, 1984.

Zarcharski LR, Moritz TE. : Effect of RA-233 (mopidamole) on survival in carcinoma of the lung and colon. Final report of VA cooperative study #188. *Thrombos Haemost*. 58 (suppl), 508, 1987.

Zacharski LR, Rickles FR, Henderson WG, Martin JF, Forman WB van Eeckhout JP, Cornell CJ, Forcier RJ. : Platelets and malignancy. Rationale and experimental design for the VA Cooperative Study of RA-233 in the treatment of cancer. AM J Clin Oncol. 5, 593, 1982.

Zucker MB. : The functioning of blood platelets. Sci Am. 242, 6, 86, 1980.