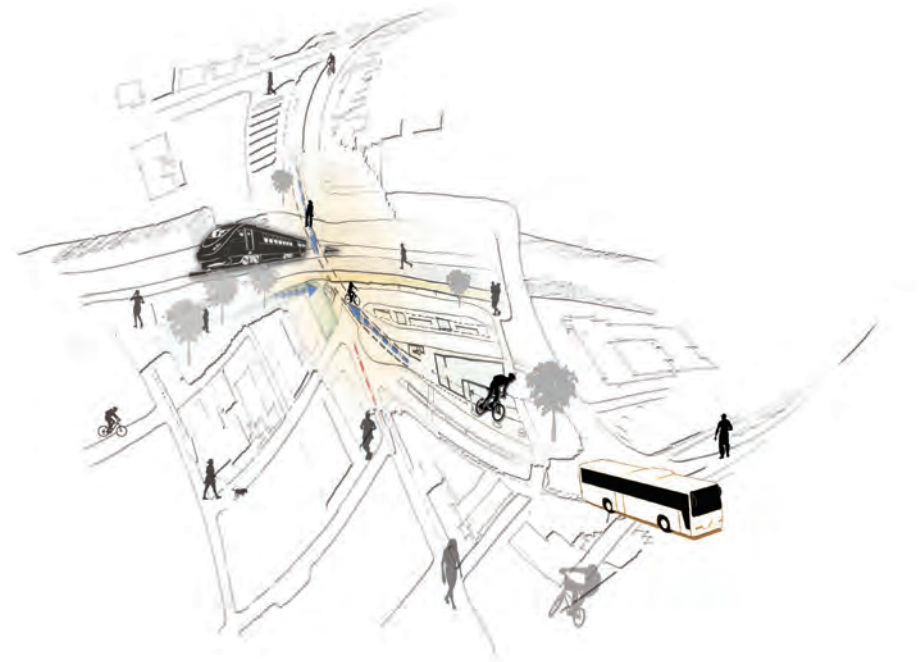


AN OASIS FOR THE URBAN NOMAD

Public Transport Interchange as an Advocate for Publicness



KURVIN VIRAHSAWMY

October 2013

The copyright of this thesis vests in the author. No quotation from it or information derived from it is to be published without full acknowledgement of the source. The thesis is to be used for private study or non-commercial research purposes only.

Published by the University of Cape Town (UCT) in terms of the non-exclusive license granted to UCT by the author.

An Oasis of the Urban Nomad

Kurvin Virahsawmy

Supervisors:

Professor Jo Noero (First Semester)

Associate Professor Nic Coetzer

Rob de Jager

Francis Carter (Second Semester)

This dissertation is presented as part fulfillment of the degree of Master of Architecture (Professional) in the School of Architecture, Planning and Geomatics, University of Cape Town.

16th OCTOBER 2013

"I hereby:

a. grant the University free license to reproduce the above dissertation in whole or in part, for the purpose of research.

b. Declare that:

(i) The above dissertation is my own unaided work, both in conception and execution, and that apart from the normal guidance of my supervisors, I have received no assistance apart from that stated below: Herrie Schalenkamp for transport interchange design input, Vishal Gaya and Alvin Harry for structural input and Vinasha Ramasamy for document layout.

(ii) Except as stated below, neither the substance or any part of the dissertation has been submitted for a degree in the University or any other university.

(iii) I am now presenting the dissertation for examination for the degree of Master of Architecture (Professional)"

Plagiarism Declaration

1. I know that plagiarism is wrong. Plagiarism is to use another's work and pretend that it is one's own.

2. I have used the Harvard convention for citation and referencing. Each contribution to, and quotation in, this report from the work(s) of other people has been attributed, and has been cited and referenced.

3. This report is my own work.

4. I have not allowed, and will not allow, anyone to copy my work with the intention of passing it off as his or her own work.

Signature _____

Signed by candidate

Acknowledgements

I wish to express my deep gratitude to my supervisors, Nic Coetzer, Francis Carter, Rob de Jager and Jo Noero, for their unwavering support and guidance throughout the year.

I extend my thanks to Herrie Schalenkamp for his kind input on the transportation aspect of the project and to Alvin Hurry and Vishal Gaya for their structural input regarding the bridge design.

I also wish to thank Melanie Ohlson from the City of Cape Town for providing the drawings of the existing Mowbray Public Transport Interchange.

My heartfelt thanks to the whole M.Arch Class of 2013: for your friendship and especially my studio buddies, for brightening up the studio.

Last but not least thanks to my family and Vinasha for their ongoing support.

Abstract

The construct of the urban landscape is made up of different spaces consisting of diverse typologies and various tones from public to private. These spaces, irrespective of their traits, play an important role in the life of a pedestrian, a commuter, the 'man on the street': An urban nomad. Publicness, complemented by ideas of cultural configuration and the concept of third space, forms the core literature for the architectural enquiry. The dissertation looks beyond the notion public and private spaces and rather sees those spaces as a platform that may favour social interactions, often referred to as 'public spaces'. The architectural agenda was to create a soulful space that allows a criss-crossing of an array of different cultural configurations. The site, being a key determinant to the enquiry, helped to crystallise the idea and thus emerged the creation of the Oasis for the Urban Nomad. The Mowbray Public Transport Interchange, being the ideal location for the oasis, led to the formulation of the architectural intervention: A transport hub that transcends the conventional notion of a transport utility. The built form helped to bridge the divide caused by the railway line and thus create a better fusion of the fragmented parts of Mowbray. The Transport hub/Oasis of the Urban Nomad, besides becoming an integral part of the Urban Nomad's daily journey, may be seen as a primer for an incremental [re] development of the area.

Table of Contents

Plagiarism Declaration	i	
Acknowledgements	ii	
Abstract	iii	
Preface	1	
1.0 Introduction	3	
1.1 The beginnings	3	
2.0 Theoretical Underpinnings	5	
2.1 Theoretical Backbone	5	
2.1.0 Publicness	5	
2.1.1 Cultural Landscape	5	
2.1.2 Third Space	6	
2.2 Publicness in Architecture	6	
2.3 Publicness in the context of Cape Town	7	
2.4 Public Transport interchange [PTI] as a precursor for publicness	7	
2.5 Towards the design of the Oasis for the Urban Nomad	8	
3.0 The Site: Unpacking its “Publicness” potential	9	
3.1 Site Description	10	
3.2 Built Fabric	11	
3.3 Vehicular and Pedestrian circulation on site	14	
3.4 Critical analysis	14	
4.0 Site and Urban Strategy	17	
5.0 Programming towards publicness	23	
		6.0 Combining the theoretical findings and the strategies to formulate an architectural intervention towards publicness 25
		6.1 The Island of Publicness 25
		6.2 The East Gateway 27
		6.3 The Circulation Tower 29
		6.4 Covered Pathway 29
		7.0 Technical Investigation 31
		8.0 Conclusion 33
		9.0 Glossary 35

List of Figures

Figure 1 Representation of how I perceive the various degrees of 'openness' of public space	3	Figure 20 Map of the proposed bicycle path and possible connections to existing paths	17
Figure 2 Snapshots of a pop-up book which depict a sequence whereby an individual proceeds to a public building from an open public park	4	Figure 21 Conceptual Urban Framework and Transport Layout	18
Figure 3 Representation, using 'waste' as building material, of what could be a 'perfect' public space: a neutral, open ground for public encounter with a roof for weather protection	4	Figure 22 Conceptual Connection between Transport modes	19
Figure 4 The entrance of the current US embassy in London with layers of security <i>top</i>	6	Figure 23 Adaptation of conceptual model to the site	19
Figure 5 Render of the New US Embassy Proposal (Studio amd, 2010) <i>left</i>	6	Figure 24 Transport Layout negotiation 1	20
Figure 6 A 5- aside soccer match catches the attention of passer bys. An active box can be seen in the background with a pedestrian pathway running along the active box, the public park and the soccer pitch ("Day 7 - Community discussion on HIV/Aids," n.d.)	6	Figure 25 Transport Layout negotiation 2	21
Figure 7 The site after the intervention (Anja Schlamann)	7	Figure 26 Transport Layout negotiation 3	22
Figure 8 The book wall and a "seating corner' with some teenagers hanging out (Anja Schlamann)	7	Figure 27 Disposition of Programs on site	23
Figure 9 The site in context (macro scale)	9	Figure 28 Site Plan showing the relationship of the building with its context	25
Figure 10 Location map	10	Figure 29 Island of Publicness	25
Figure 11 Disposition of the different structures on site	11	Figure 30 Spatial Configuration 1	26
Figure 12 The site and its surroundings	12	Figure 31 Spatial Configuration 2	26
Figure 13 Bus Movement From Cape Town (Afternoon peak)	14	Figure 32 Spatial Configuration 3	27
Figure 14 Bus Movement To Cape Town (Morning peak)	14	Figure 33 Spatial Configuration 4	27
Figure 15 Predominant Taxi Movement	15	Figure 34 Early Sketches of the Island of Publicness	28
Figure 16 Predominant Pedestrian Movement	15	Figure 36 Conceptual Model of the East Gateway	29
Figure 17 Pedestrian Walkway's height relation to buses and commuter/pedestrians	16	Figure 35 The East Gateway	29
Figure 18 Commuter's Shelter's height relation to buses and commuter/ pedestrians	16	Figure 37 The Circulation Tower	29
Figure 19 Conceptual representation of the bridge stitching the Urban fabric	17	Figure 38 Early Sketch of the Covered Walkway	29
		Figure 40 Schematic of Cobiex System	31
		Figure 39 Example of concrete finish	31
		Figure 41 Sketch of possible elevations of the bridge	31
		Figure 42 Conceptual Elevation showing the juxtaposition of the concrete structure and the steel bridge	31
		Figure 43 Conceptual Exploration	32
		Figure 44 Some technical studies in sketches	32

University of Cape Town

Preface

My profound interest in architecture for the people [public] has been the driving force behind this design dissertation. Picturing myself as part of this public, I have grown to develop my own perception of what the public /the people mean. The public, as I perceive it, is a pedestrian, a commuter, the 'man on the street': An urban nomad. The urban nomad being a 'flaneur', roams about and experiences many different spaces on his daily journey, some public and some private, some fully accessible whilst some are controlled. Irrespective of their nature the synergy of those spaces contributes to make the Urban Nomad who he is.

University of Cape Town

University of Cape Town

1.0 Introduction

An urban nomad's daily routines are greatly influenced by the various components of the urban landscape. Using the latter as his playground, the urban nomad and the urban landscape defines the city. However, the relationship of the urban nomad and the various spaces that constitute this urban landscape is inscrutable. Often it appears that public spaces are the most significant elements that affect the urban nomad. However, within this large array of different typologies and shades of private to public space, it is hard to identify which kinds of spaces are more significant to the construct of that urban landscape. Further, there is to the nomad, a blurring between the private and public nature of spaces, to an extent where the distinction is non-apparent.

Designing a public space by recreating a Roman piazza might, despite its former success, bear unexpected outcomes. An obsession with aesthetics, as opposed to the nomad's needs and comfort, may lead to an uncanny result. Even more confounding, is that some 'technically' private spaces may be viewed as more public than so called public spaces. In other words, public spaces- "the stage upon which the drama of communal life unfolds" (Carr, 1992)- are not the sole platforms for 'public activities' and interactions. Shopping malls may thus appear more welcoming than some public spaces. This disconcerting antic of the dichotomy of public and private may be explained by Publicness - a theory more often used in the social science realm but which has its merits in the architectural context.

The theory on publicness formed the backbone of this dissertation. Thus the literature on the publicness rather than public space was key to the choice of a site. Accessibility was a major determinant, sites close to a main movement corridor or in the vicinity of public transportation, were initially investigated, leading to a transport interchange as site. The Mowbray Public Transport interchange, due to its strategic location on both a micro and macro scale, was thus selected.

1.1 The beginnings

To kick off our design dissertation, we were given a series of short exercises to probe our interests and provoke ideas towards an architectural enquiry. Throughout the exercises, (Figures 1, 2 and 3) I found myself drawn towards an interrogation of the DNA of public space.

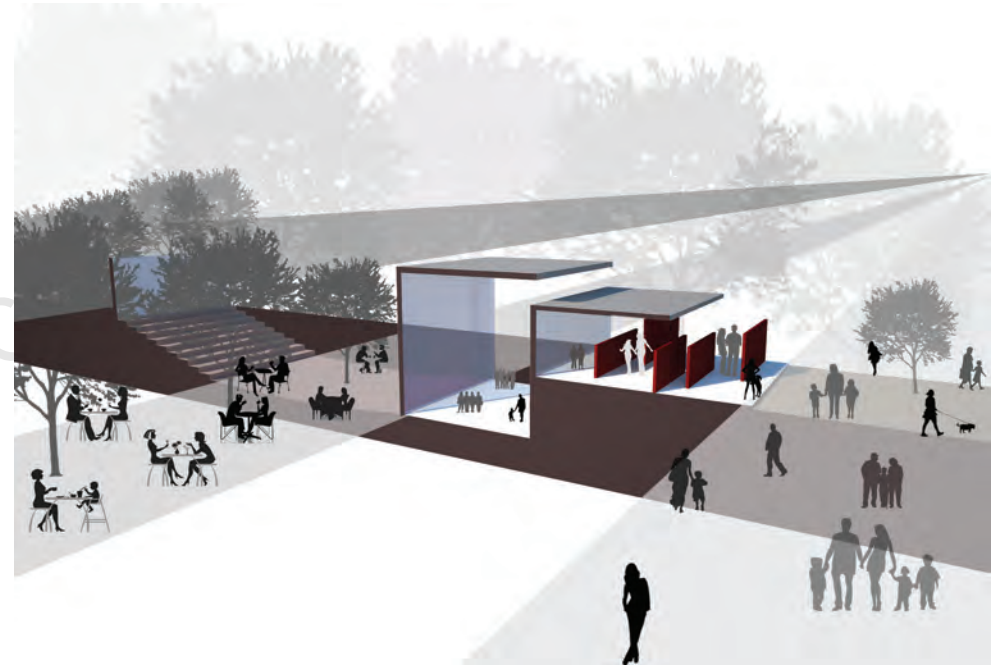


Figure 1 Representation of how I perceive the various degrees of 'openness' of public space



Figure 2 Snapshots of a pop-up book which depict a sequence whereby an individual proceeds to a public building from an open public park

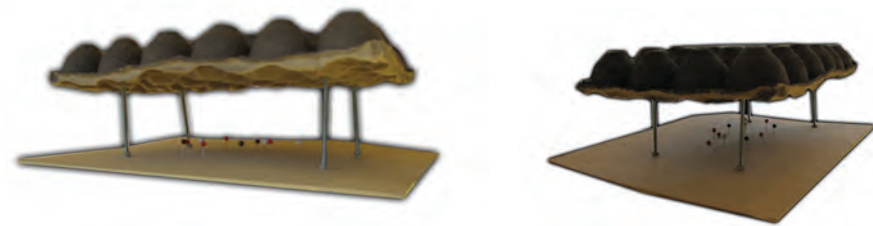


Figure 3 Representation, using 'waste' as building material, of what could be a 'perfect' public space: a neutral, open ground for public encounter with a roof for weather protection

Nowadays one is always confronted with numerous physical or social barriers in the public realm. Turnstiles control the entrance of the public library while the public park is fenced off, limiting its access point to a 'not so open' gate. The streets, which were the public haven and social playground, have almost been demeaned to circulation corridors with a constant monitoring. These observations led me to the questions pertinent to this architectural enquiry: How public is public space? What makes one space more popular than another one? What is the relevance of architecture in the creation of good public space?

2.0 Theoretical Underpinnings

2.1 Theoretical Backbone

2.1.0 Publicness

The theory underpinning the enquiry led me to the concept of publicness. Publicness attempts to quantify the elements that make one space more appealing than another. People perceive the same space differently, as a result of their different backgrounds and experiences. In other words, the level of publicness varies from one individual to the other, as much as from one public space to another. Further, as previously mentioned, a private space may be perceived as more public than a public space. To address this ambiguity of the blurring between private and public, and to be able to understand publicness, the latter is often reduced to a measuring 'unit', by sets of core dimensions (Table 1). Through this lens, publicness is more of an assessment tool, which on its own may be considered irrelevant to the architectural field. However, whilst the core dimensions constitute the basis of the theory, they over-rationalise publicness where the complexity in the relationship between a person and the space is hardly apparent. Reijndorp & Hajer's idea of cultural landscape, as well as Oldenburg's idea of third places,

Table 1 List of Core Dimensions of Publicness as identified by Madanipour, 1999; Kohn, 2004; Németh & Schmidt, 2011 and Varna & Tiesdell, 2010

Madanipour
Access Agency Interest
Kohn
Ownership Accessibility Intersubjectivity
Németh and Schmidt
Ownership Management Use/Users
Varna and Tiesdell
Ownership Physical Configuration Control Civility Animation

helps to add this intangible layer to the enquiry. Thus, parallels can be drawn between the concepts of publicness, cultural landscape and third space (Varna and Tiesdell, 2010) (Németh and Schmidt, 2011) (Hajer and Reijndorp, 2001).

2.1.1 Cultural Landscape

Hajer and Reijndorp in, *In the search of a New Public Domain*, speak of the cultural landscape as being the epitome of good public spaces and it is thus important towards publicness. The usual design of public spaces is often a mere reproduction of former successful public spaces, with an underlying agenda of reducing untidiness and focusing on aesthetics. These public spaces tend to be non-functional and limiting in the creation of opportunities for the user; thus the space lacks soul due to the missing layer - cultural configuration. Cultural configuration has various variants, namely cultural geography, cultural identity and cultural significance. The cultural configuration thus looks beyond the functionality of the space. Functionality tends to create spaces that are devoid of heterogeneous cultural spaces which create 'frictions'. In their view frictions help to create a more lively public space, thus increasing the degree of publicness of the spaces. They arise in spaces where an overlapping of subcultures and different social groups is encouraged. Such spaces take into consideration the phenomenology of space, where each person will experience the space differently. Given that a 'frictionless' space accounts for the comfort of only one particular group, it demeans the level of publicness of the spaces as it is not be perceived as public by others (Hajer and Reijndorp, 2001). In the design of public spaces, architects/designers should not simply look at private and public ownership. This is up to a certain extent is what the core dimensions assess. In line with the cultural configuration of public spaces, the space should be able to create a sense of ownership and belonging (Hajer and Reijndorp, 2001). Thus, public spaces need to have a meaning to the users which goes beyond the intended functional use of the space.

2.1.2 Third Space

In *The Great Good Place*, Oldenburg, expanding on some of the works of Homi K Bhabha, explains how important third spaces are for social interaction. Third space can be seen as a space where a heterogeneous group of people may meet neutrally. Third space pushes the boundary of social or public interaction into a more private domain. Third spaces include spaces such as restaurants, coffee shops, and other hangouts which may be technically private spaces in certain instances. Oldenburg further argues that for spaces to be considered as third spaces, they should endorse certain qualities such as affordability, accessibility, and be inviting and comfortable. To a certain degree, these attributes could also be linked back to the core dimension of publicness. However, Oldenburg emphasises the importance of a sense of belonging and ownership to third spaces (Oldenburg, 1999) (Hernandez, 2010).

2.2 Publicness in Architecture



Figure 4 The entrance of the current US embassy in London with layers of security *top*

Figure 5 Render of the New US Embassy Proposal (Studio amd, 2010) *left*

The spatial architectural qualities of a built form and its design intent have the potential to influence the publicness of a space, as well as the human perception of the space.

-In the New US Embassy in London, Keiran Timberlake Architects have been able to create an environment around the embassy precinct that fosters publicness, through their design approach to security issues. The necessary security lines that are usually offered by perimeter walls, bollards and fences are achieved through landscaping. This creates a softer and more inviting environment (Figures 4 and 5).

-The Violence Prevention through Urban Upgrading (VPUU) project in Harare, Khayelitsha, has been able to increase the publicness in areas of its inception. Active boxes (two storey-high structures, placed at strategic locations, to create a network of “watching towers”), along with a series of public amenities such as parks, sports grounds and pathways were instrumental in creating a precinct with spaces of third space quality. This precinct allows enough positive friction for the creation of a good public space. A good level of programming helps to create a passive surveillance as a diverse group of people are able to use these spaces throughout the day. This not only breeds a sense

Figure 6 A 5- aside soccer match catches the attention of passer bys. An active box can be seen in the background with a pedestrian pathway running along the active box, the public park and the soccer pitch (“Day 7 - Community discussion on HIV/Aids,” n.d.)



of ownership to a larger group of people, but also creates a sense of safety without apparent elements of control (Figure 6).

-With the Open Air Library in Magdeburg, Germany, KARO Architekten has been able to achieve a “close to perfect” public building. The library, as the name suggests, is open air and there is no control over the borrowing of books. Further, the library is



Figure 7 The site after the intervention (Anja Schlamann)



Figure 8 The book wall and a “seating corner” with some teenagers hanging out (Anja Schlamann)

configured such that the architecture allows it to be more than just a library, making it inviting for other people besides those interested in books. Although it may seem a utopian idea, this project symbolises what a public space or institution should be able to achieve- be inviting and welcoming to the whole public (Figures 7 and 8).

2.3 Publicness in the context of Cape Town

As much as the architecture may attempt to radiate publicness, at the epitome of the success of the space is the public. In other words, although all the architectural elements towards the creation of a good public space may be present, the so called public space would fail if it is not easily accessible to the public. Thus the location of such a space is of utmost importance. Mobility and accessibility are undeniable issues in the City of Cape Town, partly due to Cape Town’s long history of urban sprawl. This particularly affects the less wealthy and less than 50% of the population have access to private cars. Since publicness is fostered by the interaction of people from different backgrounds, the accessibility of such spaces by public transportation is of utmost importance. Hence, a space designed for public activities and social interaction located close to public transport, engages with an existing natural flow of people.

2.4 Public Transport interchange [PTI] as a precursor for publicness

An initial investigation of sites close to main road and public transport facilities led to the idea of public transport interchange being the ideal platform for the creation The Oasis for the Urban Nomad. Further analysis, which also included Claremont PTI and Wynberg PTI, led to the choice of the MPTI as the site for an architectural intervention. They were considered as potential sites due to their high accessibility to different demographic areas. Section 3.0 provides a detailed analysis of MPTI and justifies the choice of the site.

A PTI is the point of transit where different modes of transport meet, offering a location,

which in essence brings the public together. A PTI also allows an array of cultural configurations to overlap and thus offers a high level of positive friction, important for the creation of a soulful public space. Further PTIs offer many opportunities that may contribute towards a positive urban living environment and simultaneously enhance the public realm (Verster, 2003) (Edwards, 2011). In transcending the notion of being simply a transport hub which comes with strict engineering requirements (Appendix A), PTIs can make significant contributions in different spheres, namely social, economic and spatial design (Verster, 2003) (Edwards, 2011). The constant flow of people generated by the PTI for example, offers a viable ground for economic activities to happen. June Taylor in New railway stations as catalyst for regeneration and urban hubs proposes that aside from acting as a link between different transport modes, today's PTI can integrate different parts of the urban fabric by being a destination in itself (Taylor, 2011). Edwards, on the other hand, views PTIs as a 'new form of community hub', acting like an 'urban magnet' that has the ability of attracting both the rich and the poor, resulting in the previously mentioned multitude of cultural configurations. PTIs can also bridge the divide created by railway tracks, and hence act as physical elements that bind the fragmented part of its surrounding (Taylor, 2011).

2.5 Towards the design of the Oasis for the Urban Nomad

The literature set the basis towards the creation of the Oasis of the Urban Nomad. As mentioned, the location of the oasis is instrumental. The site (section 3.0) should have third space qualities on a macro scale and be able to provide a ground for a social interaction to happen deliberately. Further, the cross programming (section 5.0) geared towards the creation of third spaces on the site can help to enhance the publicness potentials of the site. Finally, without a negotiation between the transport requirements and that of the urban nomad, the Oasis of the Urban Nomad might simply collapse.

3.0 The Site: Unpacking its "Publicness" potential



- Settler's way / N2
- M3 /De Waal Drive
- Liesbeek Parkway
- Rhodes Ave/John Street/St Peters Rd/Durban Rd
- Main Road/M4
- Metrorail Southern Line

Figure 9 The site in context (macro scale)

3.1 Site Description

The MPTI was chosen predominantly on the basis of its accessibility and inherent qualities allowing for a public space to 'sprout'. On a macro context, (Figure 9) the interchange is ideally situated with a high accessibility to the Cape Flats, Cape Town and the rest of the Southern Suburbs. On a micro context (Figure 10), the interchange is situated in close proximity to Main Road (M4) and next to the Southern Rail way line. The West side of the interchange is mainly commercial while the East side is mostly



Figure 10 Location map

residential. In the vicinity of the interchange are the Mowbray Town Hall, the Mowbray Library, The Mowbray Maternity Hospital and the Thandokhulu High School (whose students mainly come from the Cape Flats). The student flux of this part of Mowbray is accentuated by the various UCT residences, CPUT Mowbray campus and other privately run student accommodation complexes.

The MPTI caters mainly for three different transport modes, namely trains (The Metro Rail), buses (Golden Arrow) and mini bus taxis. The Jammie Shuttle which is the UCT Shuttle Service for students and staff also makes use of the station as one of its stops and destinations.

The MPTI has the seventh busiest bus terminal in Cape Town with 5250 passengers alighting and boarding the buses throughout the day (City Of Cape Town, 2006). This is mainly due to the fact that the station is found on a major bus route from Khayelitsha, Mitchells Plain, Nyanga, through the Klipfontein corridor to Cape Town (City Of Cape Town, 2006). Personal observation has revealed that a large percentage of the 5250 passengers travel during the morning and afternoon peak times.

The Mowbray Train Station is the fifth train station on the Southern Line from Cape Town. The Southern Line serves the Southern Suburbs up to Fish Hoek and Simon's Town. The Mowbray station is busy during peak time with a train occupancy of about 7% overcapacity between Mowbray and Salt River during peak hours (City Of Cape Town, 2006).

The Taxi rank has the highest usage of the three modes of transport. The mini bus taxis offer various routes from the Cape Flats to Cape Town via Mowbray. Some minibus taxis end their journey at MPTI while others go all the way to Cape Town. On the Wynberg-Cape Town route, the minibus taxis operate on main road and hardly use MPTI despite having a dedicated berth at the West taxi rank. The East taxi rank remains busy throughout the day as opposed to the bus and train station. The West Taxi rank has a significantly lower usage than the East one (Section 3.3).

3.2 Built Fabric

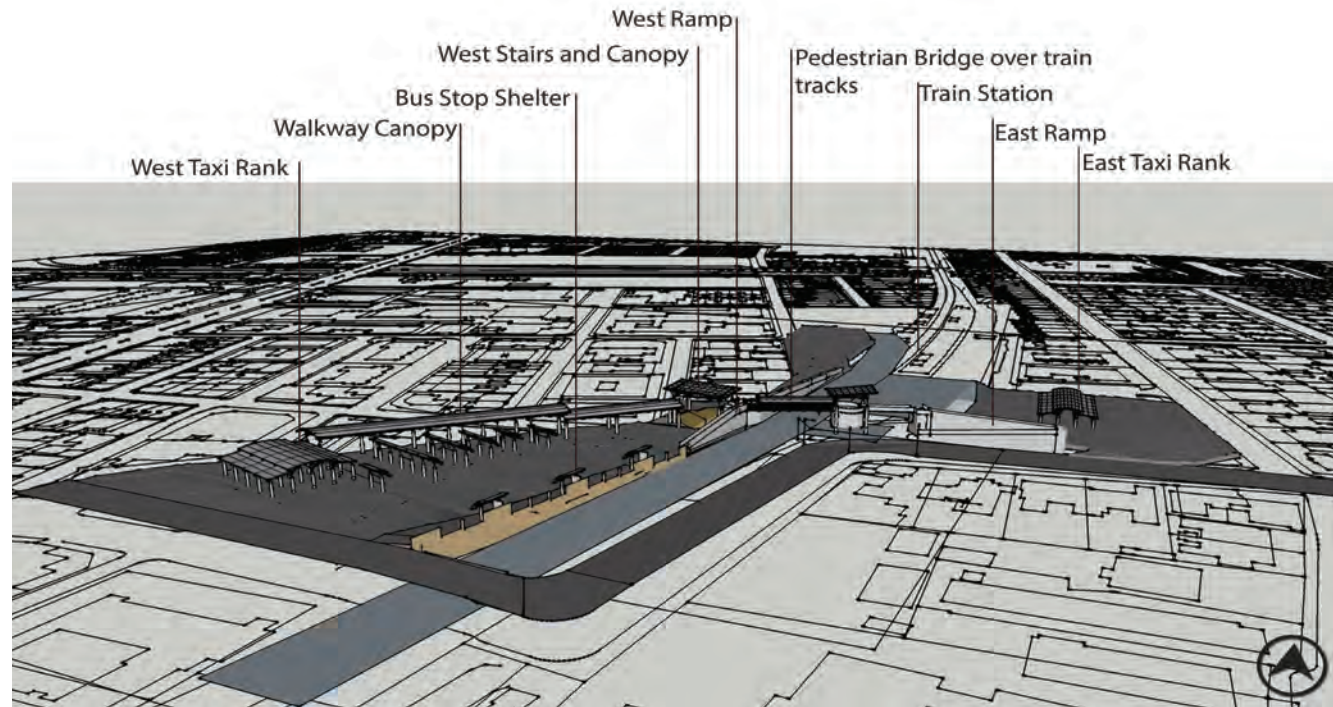


Figure 11 Disposition of the different structures on site

The interchange is found on an odd shaped site which can be segmented into three different sites; Train station fore court, the West rank and the East rank (Figures 11 and 12). The site slopes with a gradient of 1:40 from the West rank to the train station fore court. The East rank sits at 3m lower than the lowest point of the West rank. The railway line cutting across the site acts as a physical barrier, which together with St Peter Road, separates the East and West parts of the site. The train station is found in the Northern apex of the site.

The Train Station Fore Court

The forecourt of the train station consists of a paved area. A ramp and a paved walk-way are the only connections between the MPTI and the train station.

The West rank

The West rank consists of a taxi stand, a bus terminal, an administrative block, a public bathroom, an information kiosk, shelters and covered walkways.

Train Station Forecourt



Traders along existing Bridge



View up John's Street and Upper Durban Rd

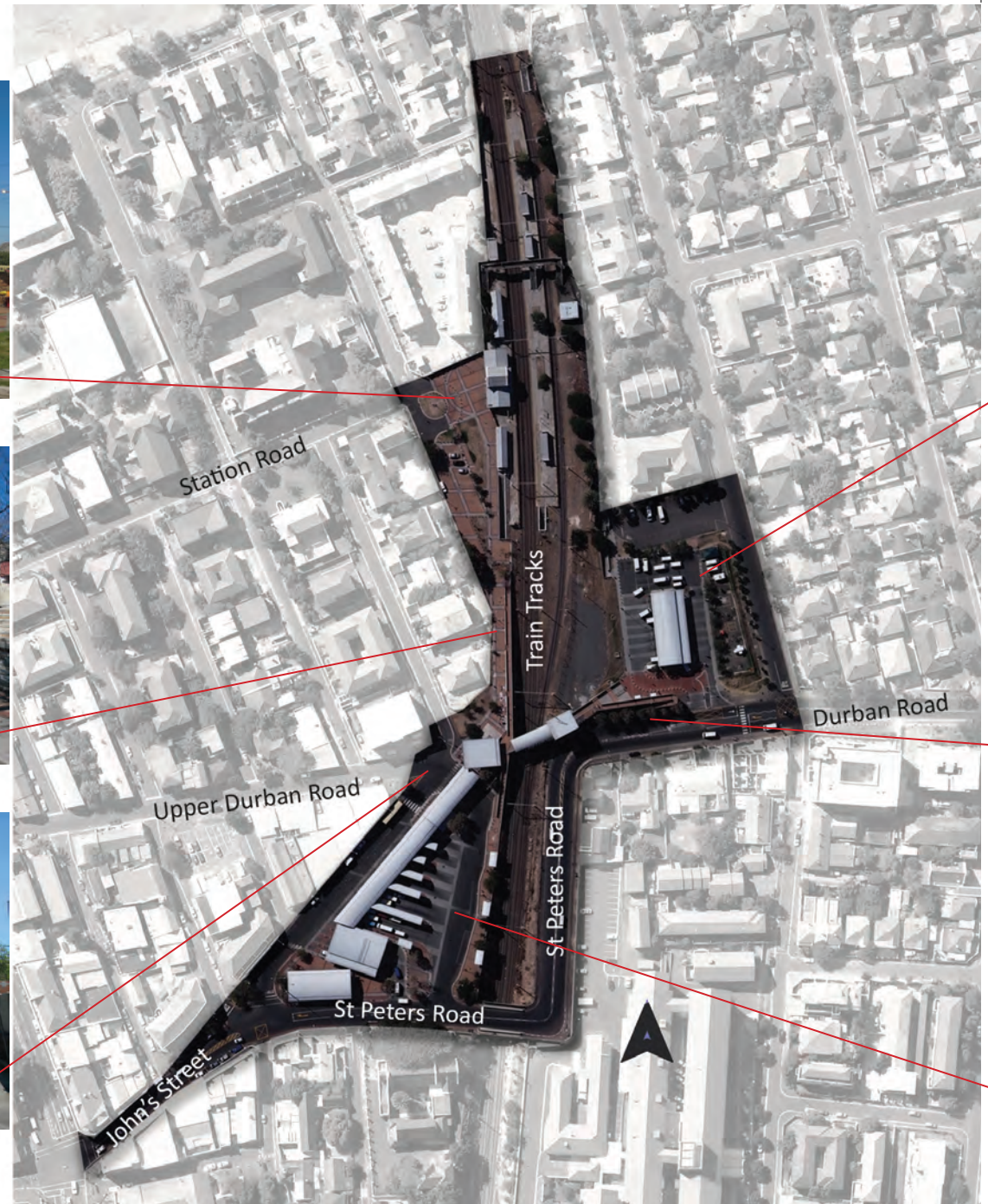


Figure 12 The site and its surroundings



East Rank



Pedestrian Circulation Core



West Rank



The East rank

The East rank consists of a taxi stand, a security booth, a public bathroom and an information kiosk.

The Pedestrian circulation core

The PTI is designed around the main circulation core which attempts to bind together the fragmented parts of the site. The circulation core consists of the pedestrian bridge with its ramps and stairs and the pedestrian walkways (Appendix B). The bus station runs perpendicular to the pedestrian walkway that leads to the main stairs, up to the pedestrian bridge. The train station, as mentioned previously, is linked to the main pedestrian circulation core by a ramp leading to the pedestrian bridge and by an unprotected walkway leading to the bus station. On the east side, the taxi rank is linked to the main circulation by a set of stairs.

The ramps on the West side house nine storage spaces meant to be used as retail stores. The ramps on the East side house a security booth, a public bathroom, an information kiosk and a utility room used by the cleaning department of the City Improvement District.



3.3 Vehicular and Pedestrian circulation on site

The vehicular motion on and around the MPTI varies throughout the day and across the different modes. However, there is a clear distinction between morning peak hours (07 00 – 08 30), afternoon peak hours (16 00 – 18 00) and non-peak hours. Buses and minibus taxis are more frequent during peak hours. During off peak times, the minibus taxi retains considerable movement in and out of the PTI but the bus occupancy is reduced to no more than two. The mini bus taxi rank on the East side is busier throughout the day as opposed to the West one as most taxis tend to stop on the side of the road to pick up and drop off commuters. Figures 13 to 15 depict the vehicular motion at the MPTI throughout the day.

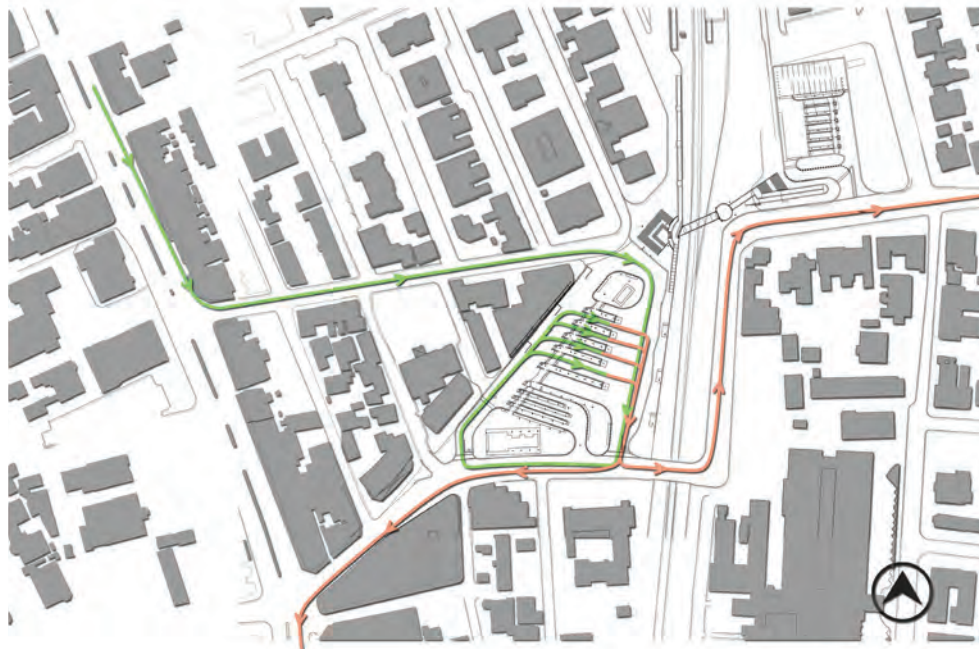


Figure 13 Bus Movement From Cape Town (Afternoon peak)

The pedestrian movement is persistent throughout the day as the bridge, which is the only formal pedestrian crossing linking both sides of the railway line, is used both by the commuters and other pedestrians. There is however more traffic during peak hours, coinciding with maximal vehicular traffic. Figure 16 depicts the predominant movement patterns of the pedestrians across and around the site.

3.4 Critical analysis

MPTI is an important element of the Mowbray urban landscape and is essential to Cape Town's public transport system. However the PTI fails to comply with some of the basic requirements of the National Department of Transport Guidelines (Appendix

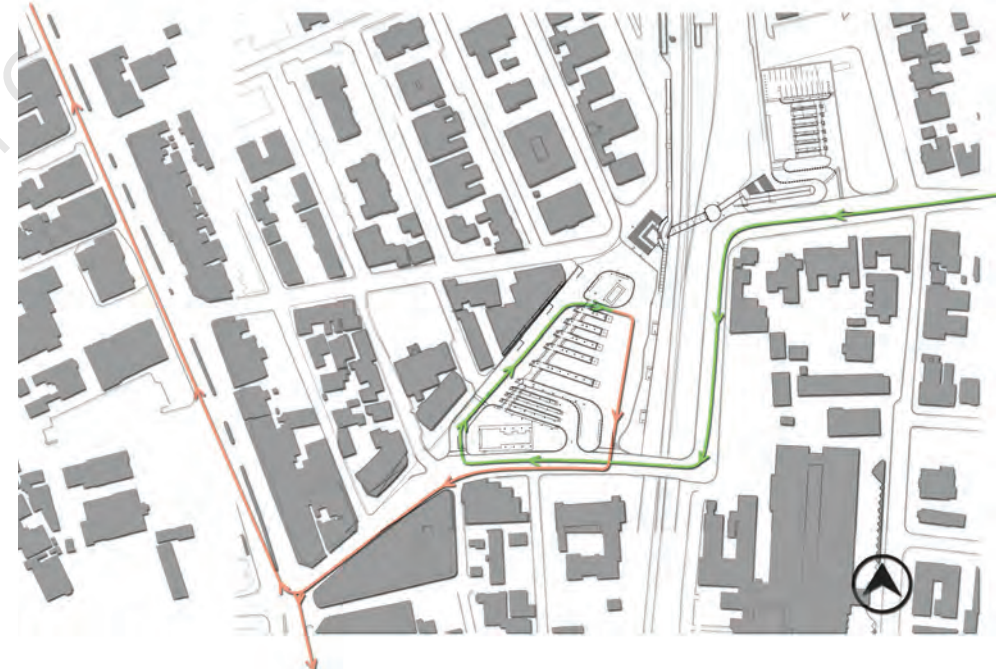


Figure 14 Bus Movement To Cape Town (Morning peak)

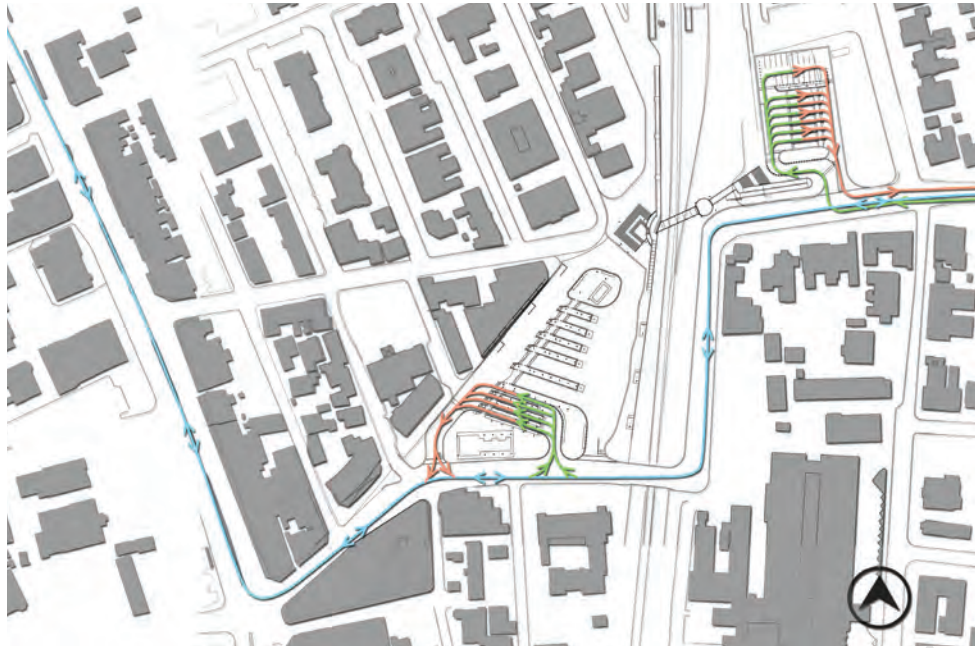


Figure 15 Predominant Taxi Movement



Figure 16 Predominant Pedestrian Movement

A). Despite the fact that it is well situated on a macro scale, the MPTI does not address its immediate surroundings properly, consequently impairing both its functionality and the user experience.

Functionality

The MPTI appears to have been designed to deal solely with peak hours during the day, when it is actually used to full capacity. During off peak hours however, which amount to more than half of the day, the design of the transport interchange limits its use. The shape of the layout, which is mainly due to the site geometry, causes a limited economy of space. The dedicated bus lanes are of varying lengths, but can only effectively accommodate one bus each. Further, they are hardly used during the greater

part of the day, whilst the structures occupy most of the space. The geometry of the site also requires the buses to make a complete loop before getting into the bus lanes (Figures 13 and 14).

As mentioned before, a PTI should have the ability to bridge the fragmented parts of an area arising from a railway line or a main street (or a highway) acting as a physical barrier. In the MPTI, the bridge along with the stairs and ramp system serves this purpose. However they fail to 'create a seamless connection' that integrates the East and the West side of the railway line. Instead, the ramps and stairs obstruct the visual connection and accentuate the 'barrier-effect' of the railway line.

User experience

The MPTI fails to strike a right balance between the requirements of commuter/pedestrians and that of public transport. It is highly over-functionalised and thus the spaces are predominately designed for vehicular use as opposed to human comfort.

The pedestrian walkways, along with the shelters, were built to accommodate the height of buses (Figures 17 and 18). Further the use of different roof types along with corrugated sheeting – vault-type for the bridge and walkways and flat roof canopies - cause awkward connections between the different parts of the roof which have not been dealt with in the MPTI. The different roof-types thus create openings in the roof system which further impairs the ability of the MPTI to provide adequate weather protection and thus a minimum level of comfort to the commuter/public.

The design of the MPTI also lacks legibility, making it difficult for one to orientate oneself within the PTI and this lack of definition undermines the importance of such a facility in the area. Further, a lack of programming of the site is highly apparent with informal trading being the only non-transport related activity. These traders are organised in storage-like spaces bearing a roller shutter and are tucked away behind the stairs on the West side of the PTI.

These numerous issues impact negatively human comfort and on the publicness level of the MPTI. However, the ideal location of the MPTI coupled with its high accessibility gives it the inherent capability to bring together a large range of people from different social and demographic backgrounds. This overlay of different cultures

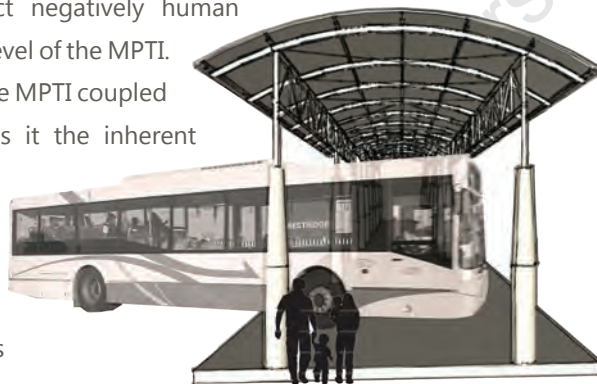


Figure 17 Pedestrian Walkway's height relation to buses and commuter/pedestrians



Figure 18 Commuter's Shelter's height relation to buses and commuter/pedestrians

may lay the foundation required for a good public space. MPTI may thus be considered a location that can potentially foster publicness should the right architectural intervention and adequate programming be implemented.

4.0 Site and Urban Strategy

The site strategy and urban design framework have the aim of unleashing the site's inherent ability to foster publicness. The strategies are a response to the different issues observed on the site (Section 3.4). An urban regenerating approach was adopted. Given the limited opportunity offered by the existing structures, the site was treated as a clean slate. Eventually, the location of the different functions such as the bus terminal, the taxi stand and the train station were maintained. This is a rational decision made on operational necessities of the PTI and the site geometry that limits the site flexibility. The design intervention is seen as a catalyst for future urban renewal and, as laying the fundamental platform for an incremental growth in the area. The different agendas are as follows:

- A sloping bridge will replace the existing bridge on the site. The configuration of the existing bridge and ramps accentuate the barrier-effect created by the railway lines and part of St Peter's Road (Section 3.4). The new bridge will allow a more seamless integration of the East side of the railway line to the West side with a gradual slope from one side to the other (Figure 19). Further, the bridge will not solely act as a foot path. In line with the non-motorised transport proposal by the City of Cape Town (as part of the Klipfontein corridor project) (City Of Cape Town, 2009) and the UCT Bike link initiative, the bridge will accommodate a bicycle track. The bicycle track will facilitate cycling from

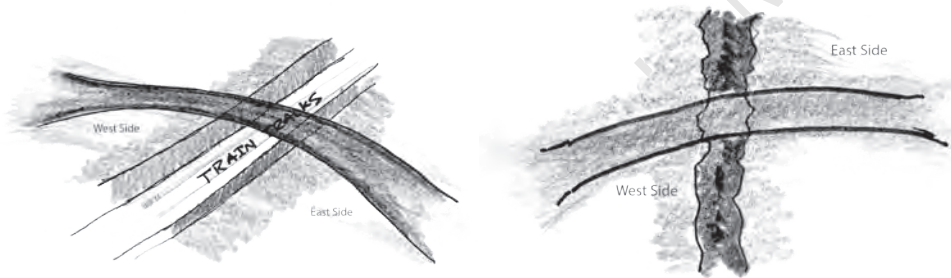


Figure 19 Conceptual representation of the bridge stitching the Urban fabric

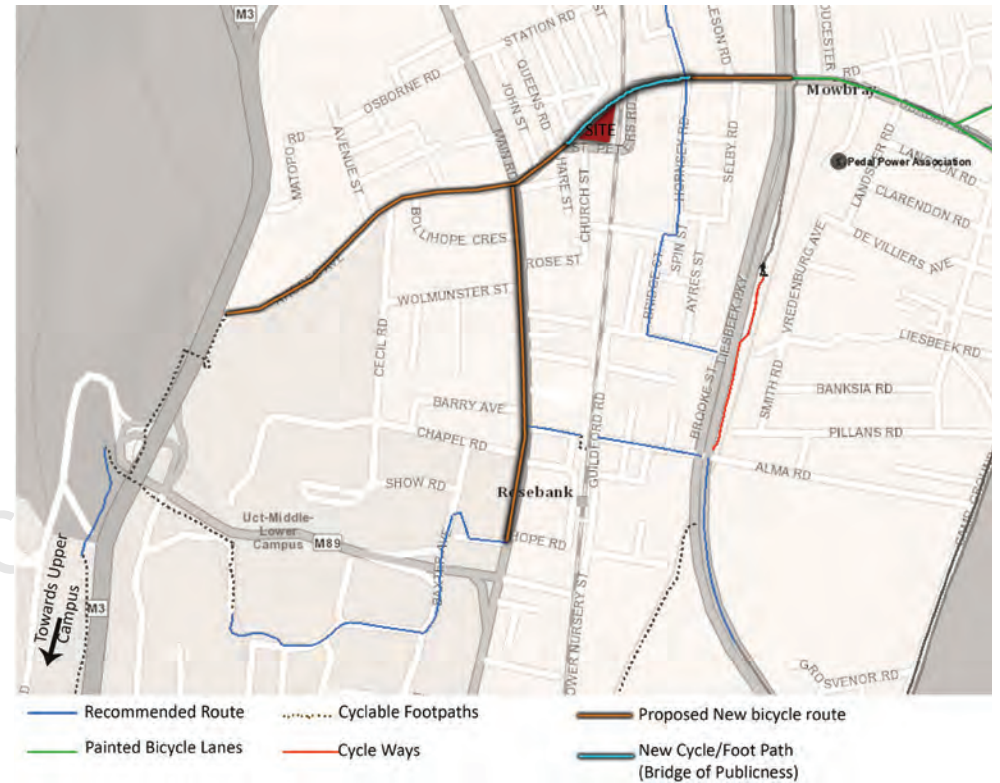


Figure 20 Map of the proposed bicycle path and possible connections to existing paths

the existing bicycle track along Durban road (east side of Leisbeek Parkway) to Main Road Mowbray (Figure 20).

- The design is expected to trigger an incremental growth with an increase in the density of the urban fabric around the PTI overtime. With an optimum use of the land around the interchange, more student-housing may be built, some of the run down shops in the vicinity of the bus terminal may also be refurbished and their bulk increased (Figure 21).



Figure 21 Conceptual Urban Framework and Transport Layout

- This was achieved through a reconfiguration of the bus terminal. The individual berths for each bus route use up a lot of space, although more than half of them remain vacant during the day. Hence, different configurations were taken into consideration and a more linear long berth approach was adopted, while making sure that the capacity of the new layout matches the existing one. Both taxi stands have also been combined into one of higher capacity on the site of the existing East side one. In doing so, the congestion around the bus terminal during peak times can be alleviated. The transport layout was finalised after consultation with Herrie Schalenkamp, ACET Research Officer, at the Centre for Transport Studies at the University of Cape Town. (Figures 21, 24, 25, and 26).

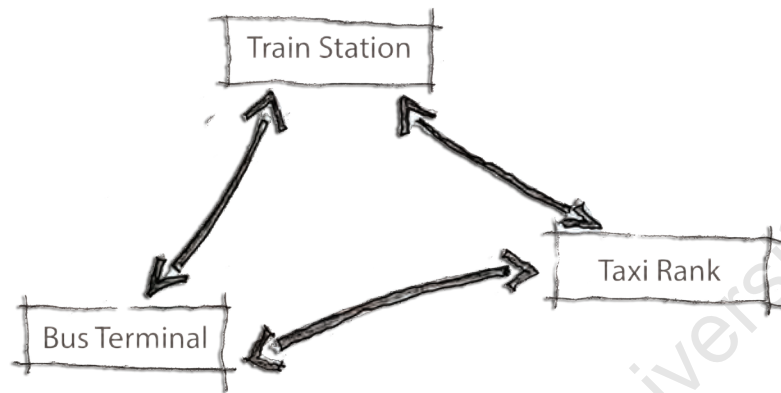


Figure 22 Conceptual Connection between Transport modes

- In order to increase the legibility of the interchange and commuter comfort, a well-defined pathway will link the train station fore court and the bus terminal. A gently sloping bridge (1:12) will replace the existing bridge ensuring a more subtle connection between the West and East sides of the interchange. The new bridge, along with the

pathway, will provide a weather protected link to the different transport modes (Figures 22 and 23). Properly protected waiting areas at the bus terminal and the taxi ranks will further increase the commuter comfort. The placement of the design intervention will ensure an increased legibility of the whole precinct by accentuating point of arrival and entry onto the interchange for the commuters.

The next part of the section (4.1) shows the different negotiations between the new transport layout and the placement of the building. Although the transport requirement is of utmost importance it should not be the driver of the design decision and implications. It should however, be given enough consideration to ensure a swift operational manoeuvre of the interchange.

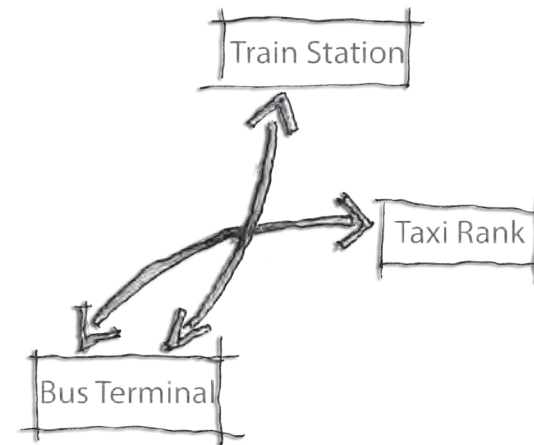


Figure 23 Adaptation of conceptual model to the site

- Bus terminal organised on both sides of the island
- Taxi Rank organised along an East-West axis.
- Bridge ends on East side of the island

- The taxi layout does not provide an optimum use of space
- End of bridge not directed towards main pedestrian flow

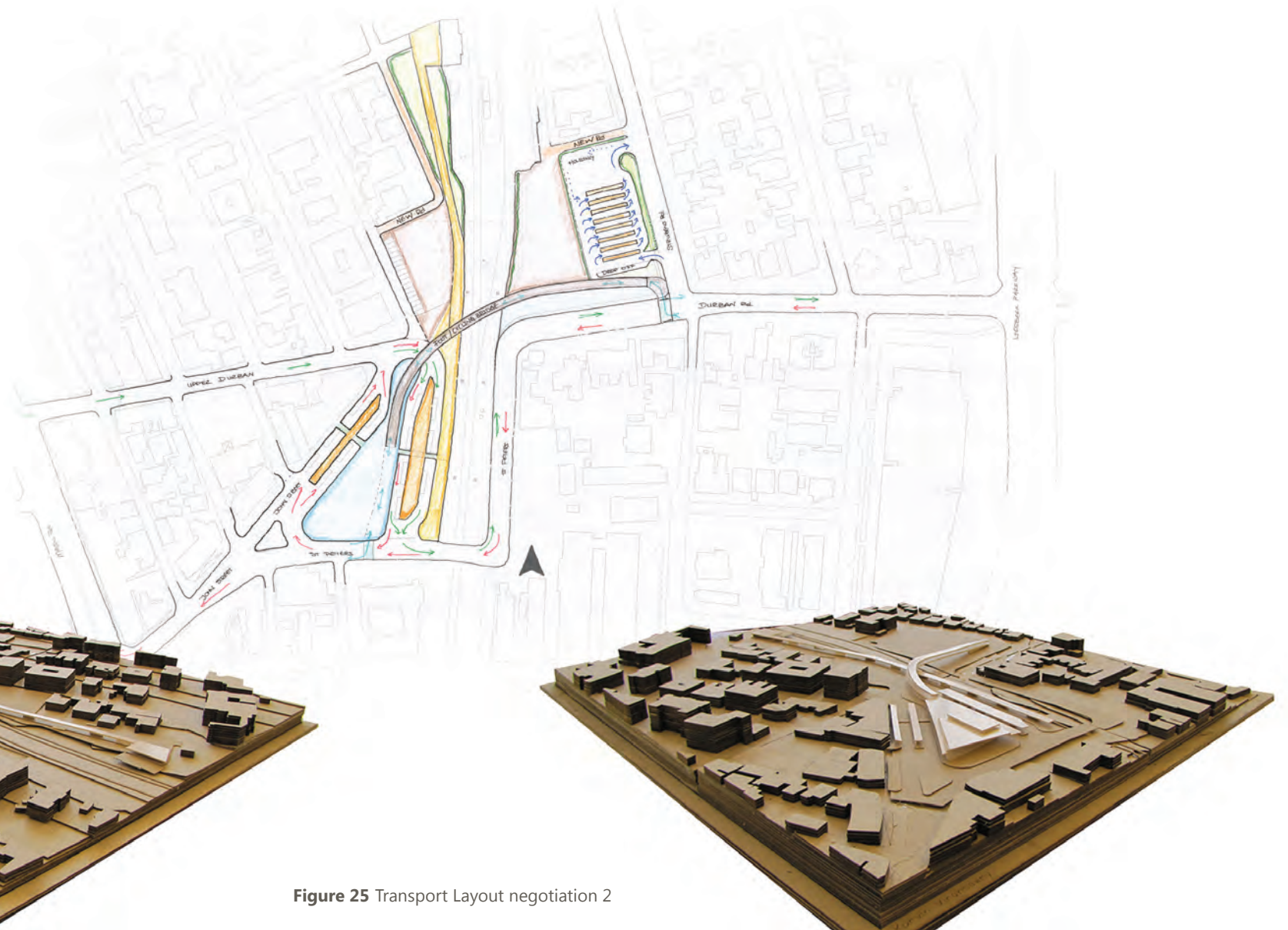


Figure 25 Transport Layout negotiation 2

-Taxi Rank organised along an North-South axis, resulting in an optimum use of space

-End of bridge is positioned towards Main Road, and thus along the main pedestrian movement

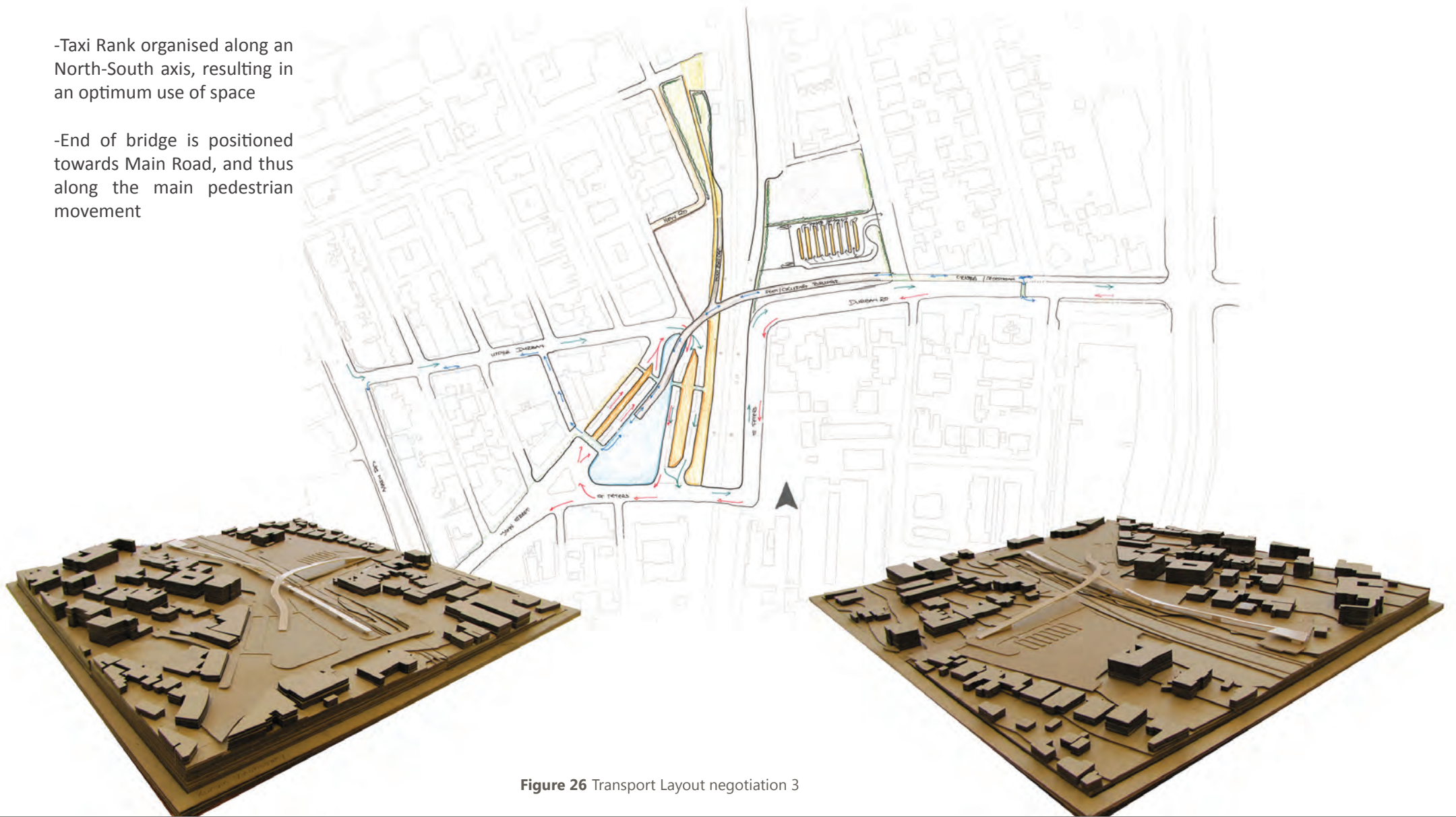


Figure 26 Transport Layout negotiation 3

5.0 Programming towards publicness

Programming is an important determinant towards the publicness of a space. Together with a built fabric that provides a pedestrian/commuter/public friendly environment, an astute programming may accentuate the level of comfort and welcoming effect of the space. Whilst a lack of programming may lead to a space devoid of a soul, an over programmed space may be too predictable, such that the phenomenology of the space is lost. Given the transient nature of PTIs and the non-negotiable aspect of operational efficiency, PTIs tend to become 'over-functionalised' and thus become mere places of transit. Furthermore, given that we are far from reaching the one minute headway between trains and buses of many European PTIs, accommodating South African PTIs with meaningful activities to turn them into a destination is a viable prospect (Verster, 2003). Thus, the programming of the site is geared towards making MPTI a destination whereby people from different backgrounds may come together for informal encounters. In order to achieve this, different specific groups need to be taken into consideration to form a whole – The urban nomad. These groups include the commuters, the students, 'transportation', the locals, bike riders, and pedestrians. What may then seem like a juxtaposition of functions in the design scheme is, in fact, a way to create a platform that

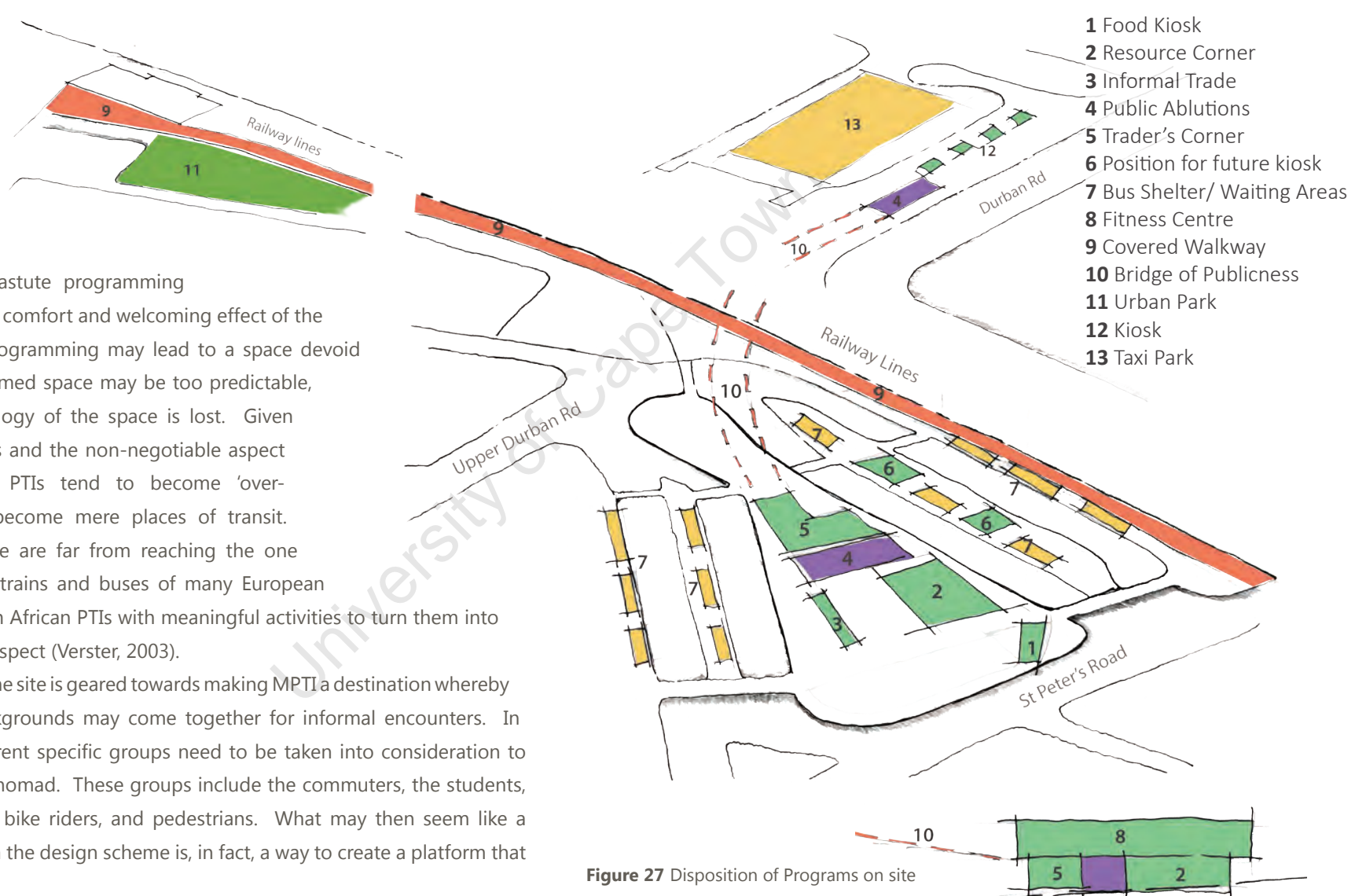


Figure 27 Disposition of Programs on site

accommodates all the different groups (Figure 27).

The programming of the site is one of reciprocity. Although the different spaces work independently and have different 'functions', they serve to reinforce each other on a macro (site) scale. However, on another level, the spatial manifestation of the programs also allows for conflict and positive friction that create third spaces and allows for social interaction. With this gaze the spaces have glimpses of what Bernard Tschumi describes as 'conflict' and what Koolhaas refers to as cross programming where a design space may have different 'use'(Lawrence and Schafer, 2006)(Tschumi, 1996).

University of Cape Town

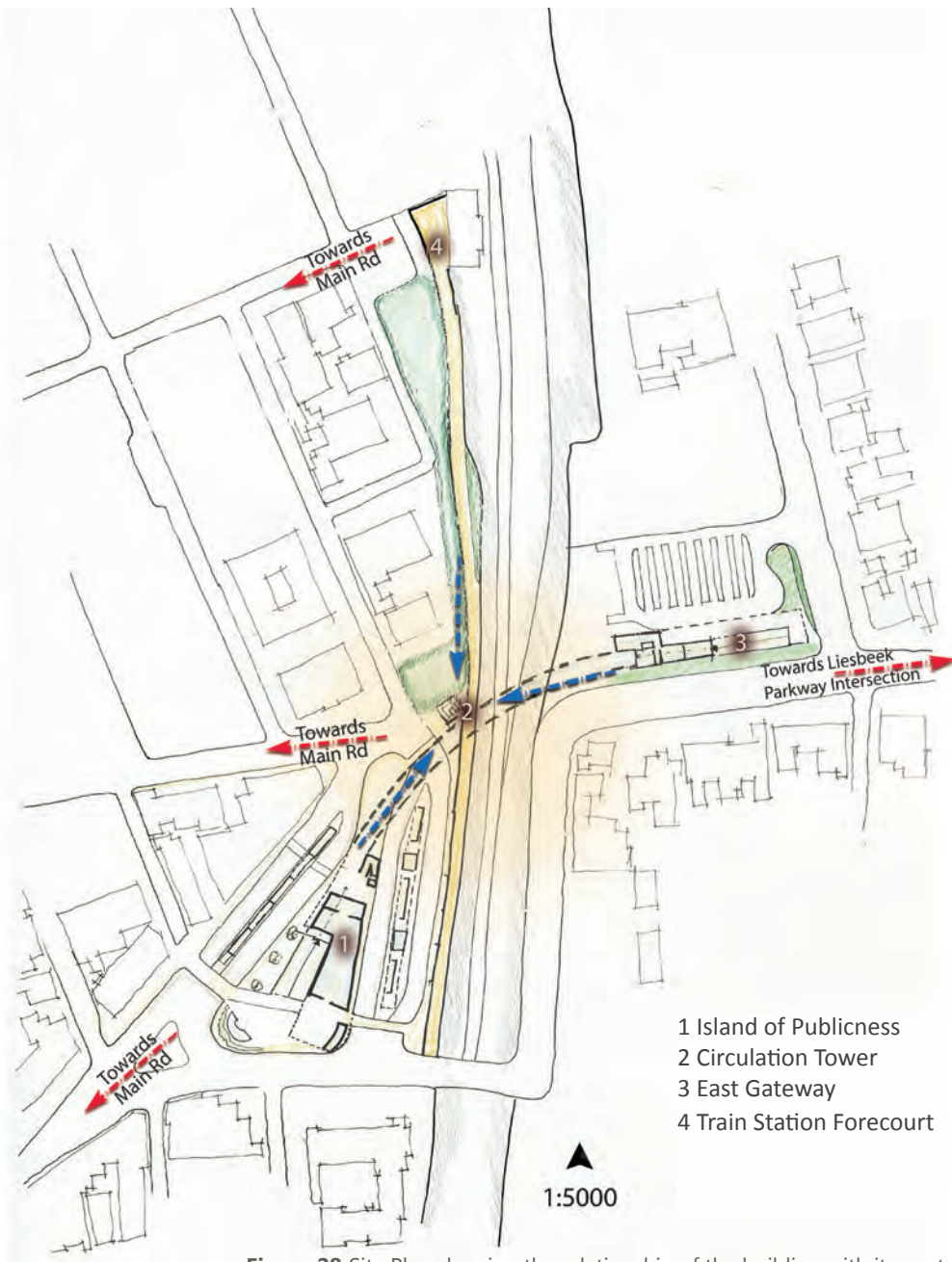


Figure 28 Site Plan showing the relationship of the building with its context

6.0 Combining the theoretical findings and the strategies to formulate an architectural intervention towards publicness

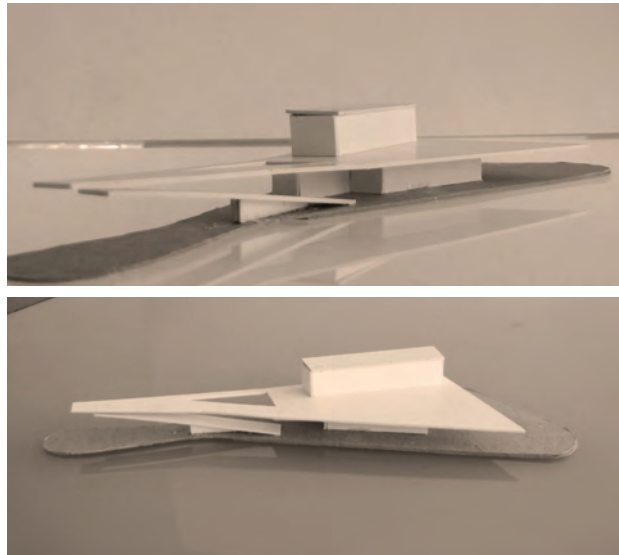
The approach to the architectural intervention is an extension of the ideas put forward in the urban design framework. The different components of the scheme consist of the bridge (The bridge of Publicness), the covered walkway, the built interventions at the two ends of the bridge (namely the Island of Publicness and the East Gateway), the circulation tower, and the bus shelters. The combination of these elements forms the Oasis for the Urban Nomad. The Train station forecourt (covered walkway), the Island of Publicness and the East Gateway form three 'bookends' which define the interchanges and act as gateways to the site, while the Circulation Tower becomes a focal point on the site, where the Bridge of Publicness 'intersects' the covered walkway (Figure 28).

6.1 The Island of Publicness

The Island of publicness may be considered as the main architectural intervention. It is located on the space freed up by the reconfiguration of the bus terminal (Figure 29). The Island of Publicness is ideally situated with a direct visual connection and access from main road. On an urban scale, an entry court for the urban nomad from main road is created by the built form (Figure 28). The latter is influenced by the location of the ramp which completes the bridge on the west side of the interchange. Figures 30 to 33 depict different configurations of the location of the bridge and ramp in relation to the building. These investigations were carried out in concurrence with the transport layout.

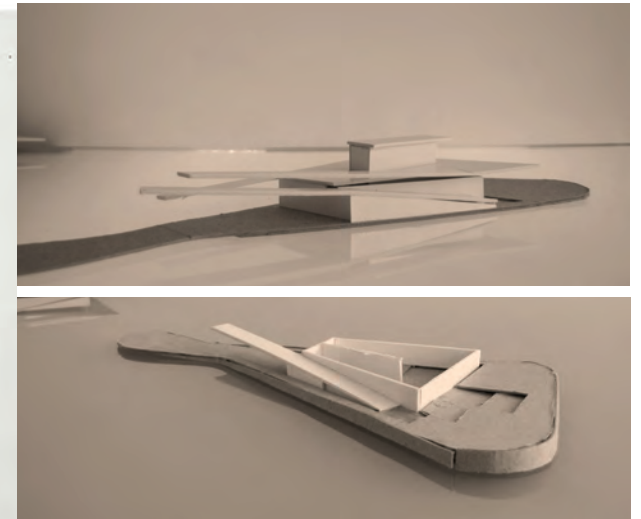
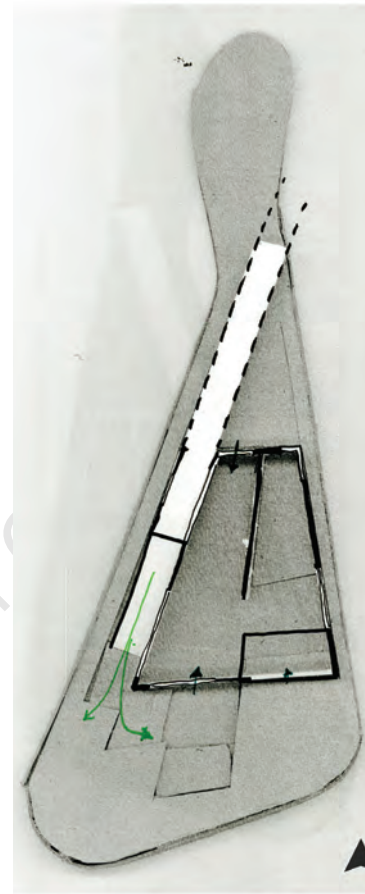
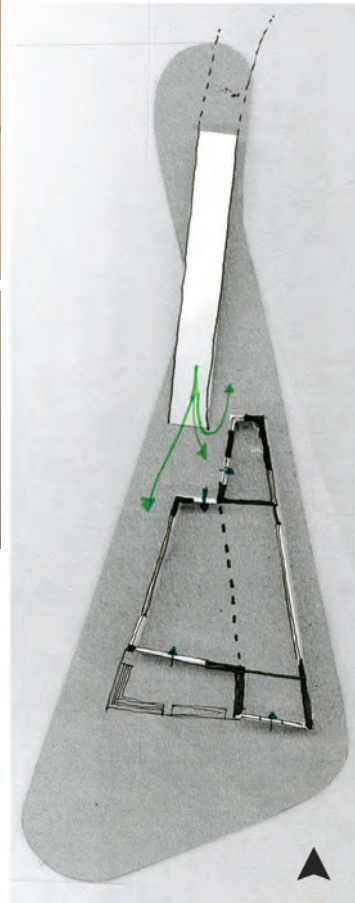


Figure 29 Island of Publicness



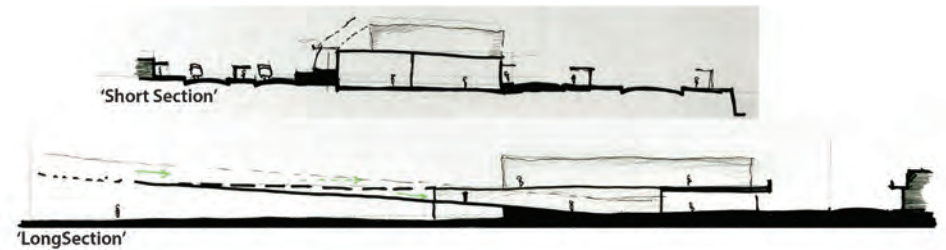
The ramp and the building are treated as different entities, thus creating a visual barrier on the North side.

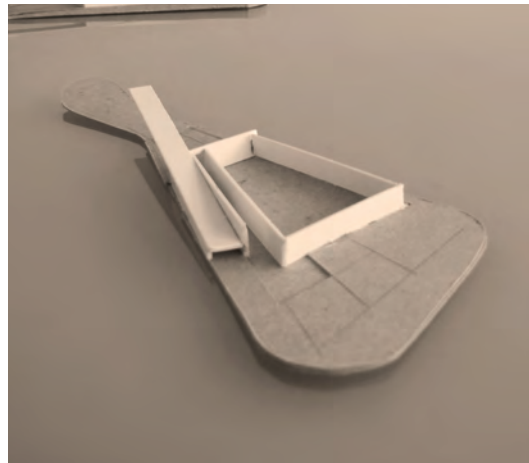
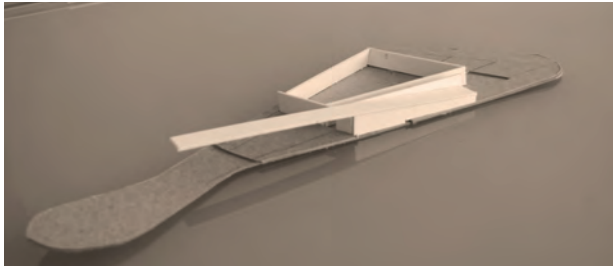
Figure 30 Spatial Configuration 1



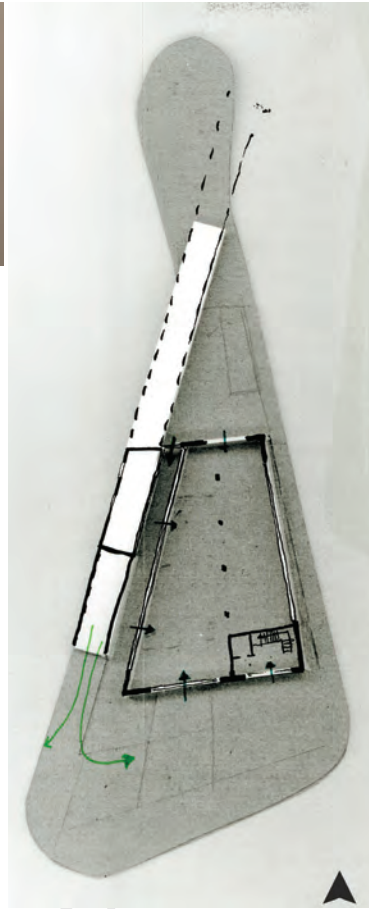
The ramp forms part of the building, thus eliminating the visual barrier effect.

Figure 31 Spatial Configuration 2



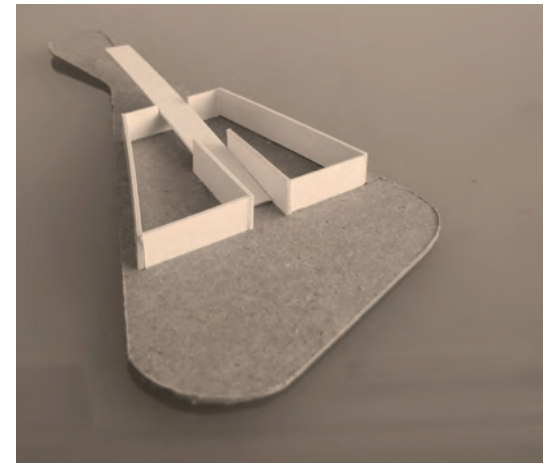
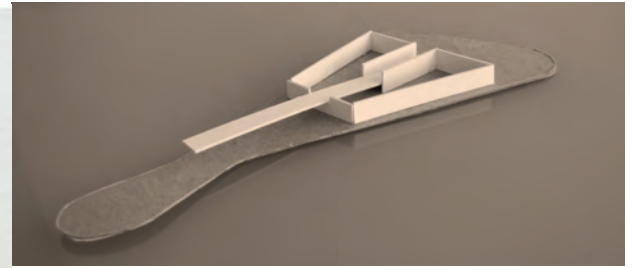
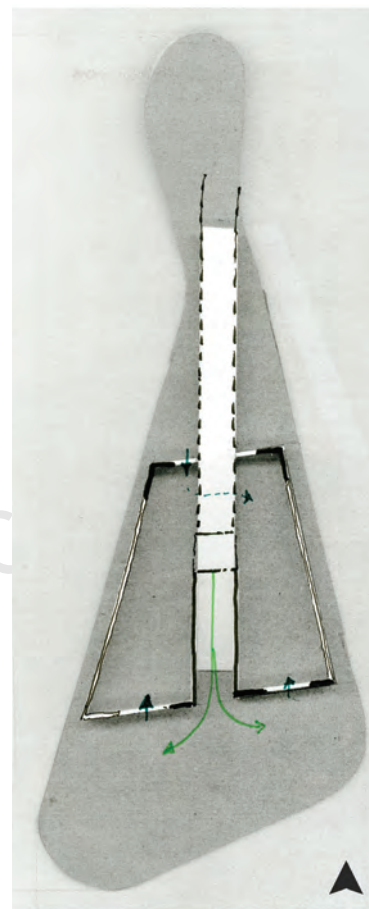


6.2



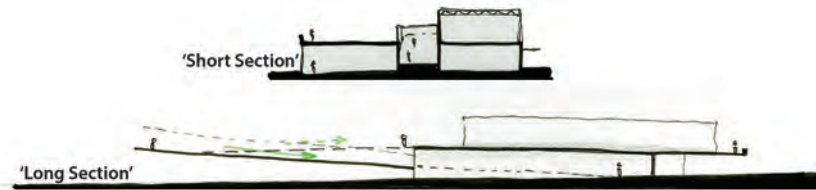
The ramp is taken to the edge of the West side of the Island, thereby creating a walkway between the building and itself.

Figure 32 Spatial Configuration 3



The ramp running through the building creates two distinct spatial configurations.

Figure 33 Spatial Configuration 4



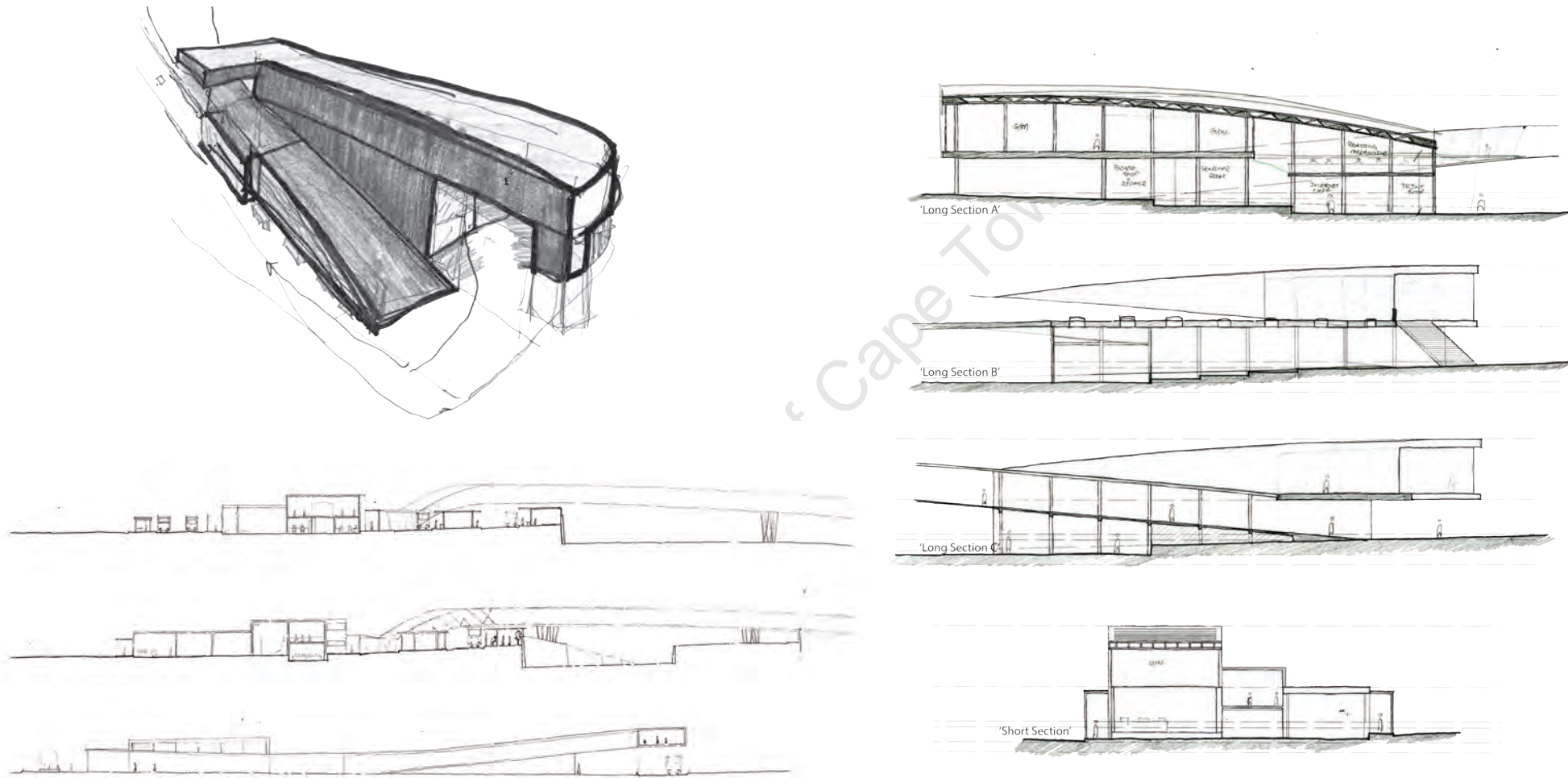


Figure 34 Early Sketches of the Island of Publicness

The East Gateway

The East Gateway is the entry court from the east side of the interchange. It has a direct visual connection to the Durban Rd and Liesbeek Parkway intersection (Figures 35 and 36).

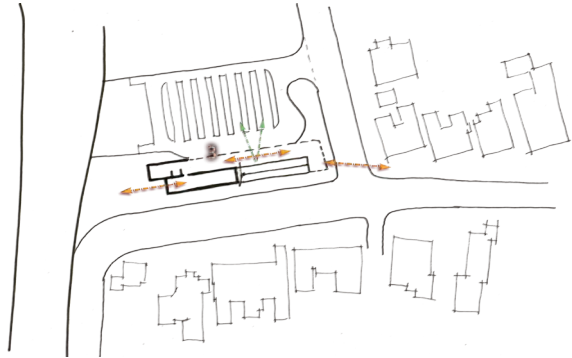


Figure 35 The East Gateway

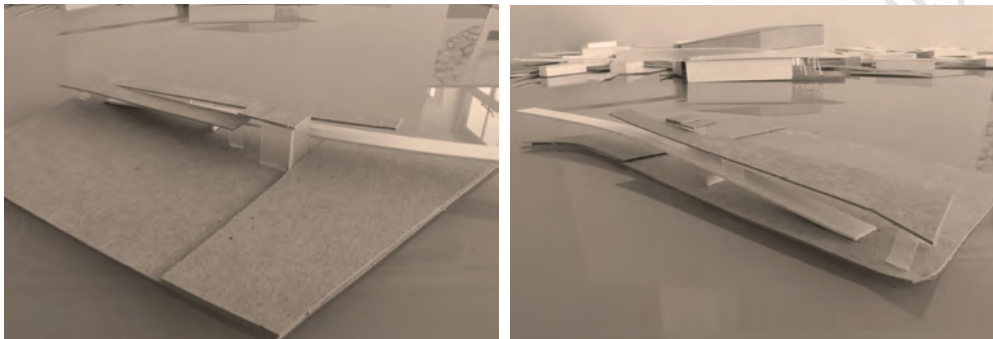


Figure 36 Conceptual Model of the East Gateway

6.3 The Circulation Tower

The Circulation tower, as mentioned previously, may be seen as the focal point of the site. It is visible from the Train Station, the Bus terminal, Taxi rank and is aligned along the axis of Upper Durban road, from main road (Figure 37).

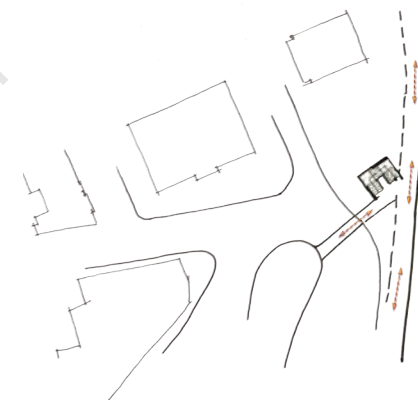


Figure 37 The Circulation Tower

6.4 Covered Pathway

The covered pathway links the Train Station to the Bus terminal (Figure 38). On the Train Side, the covered pathway acts as one of the gateways to the PTI. On the Bus Terminal Side, the pathway also includes bus shelters.



Figure 38 Early Sketch of the Covered Walkway

University of Cape Town

7.0 Technical Investigation

The Main buildings

The use of off-shutter textured concrete for the main buildings, namely the Island of publicness, the East Gateway and the Circulation Tower, gives them a presence on the site while simultaneously achieving a robust finish that is essential for such a site. A public transport interchange is required to sustain a heavy pedestrian and vehicular movement, thus making a hard wearing finish of utmost important. The timber board shuttering system helps to soften the bold nature of off shutter concrete (Figure 39). With its 'imperfection' and the timber pattern, the timber board also adds a certain character to the building. The fluid characteristic of concrete allows for the making of the curved and tapered 'concrete box' that houses the fitness zone at the Island Of Publicness and the roof of the East Gateway.



Figure 39 Example of concrete finish

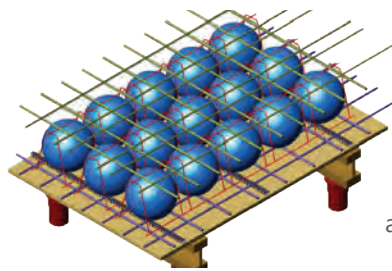


Figure 40 Schematic of Cobiax System

In order to reduce the dead load of the building and to ensure an optimum use of material, a polystyrene void formers system [Cobiax] was used. The polystyrene balls displace the concrete where no structural strength is needed which allows a reduction of about 35% of the concrete use (Figure 40). The system allows a flat span with a

reduced depth to span ratio, thus allowing large spans and a reduced number of column; an important feature for the design of the fitness centre (Cobiax Technologies AG, 2010).

The Bridge of Publicness

Using a combination of steel, metal sheeting and clear polycarbonate panel, the bridge is designed as a light structure to contrast the heaviness of the main buildings (Figure 42). The bridge is made up a modified truss system with an underlying concept of a slinky spring (Figure 43).

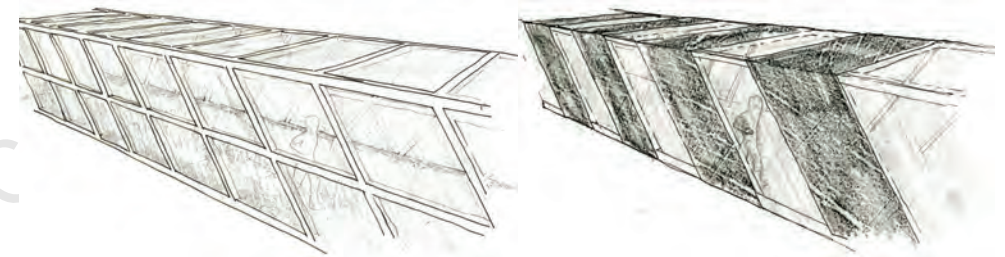


Figure 41 Sketch of possible elevations of the bridge

Figure 42 Conceptual Elevation showing the juxtaposition of the concrete structure and the steel bridge

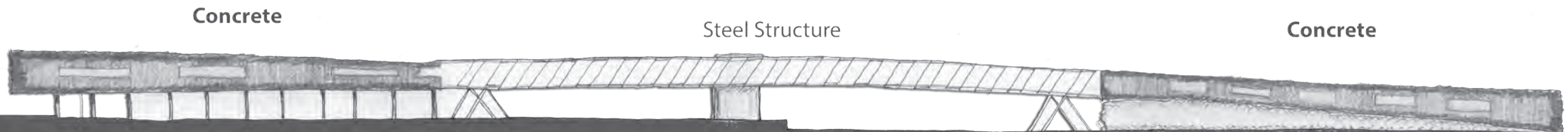


Figure 43 Conceptual Exploration

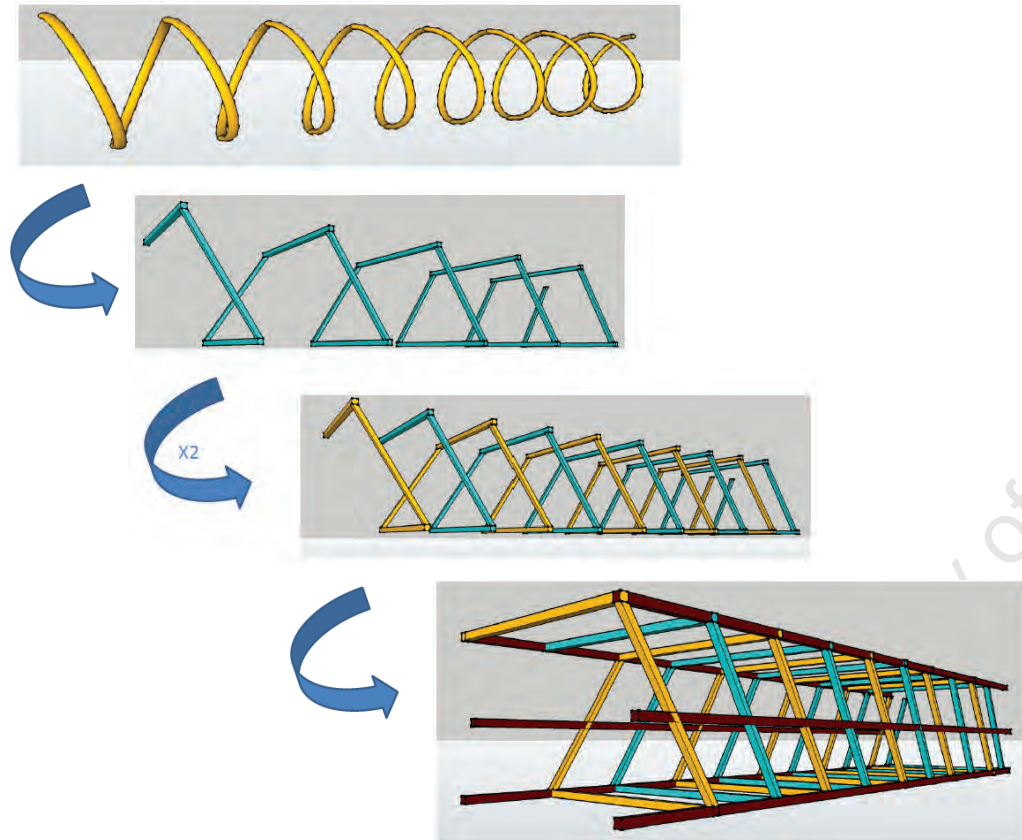
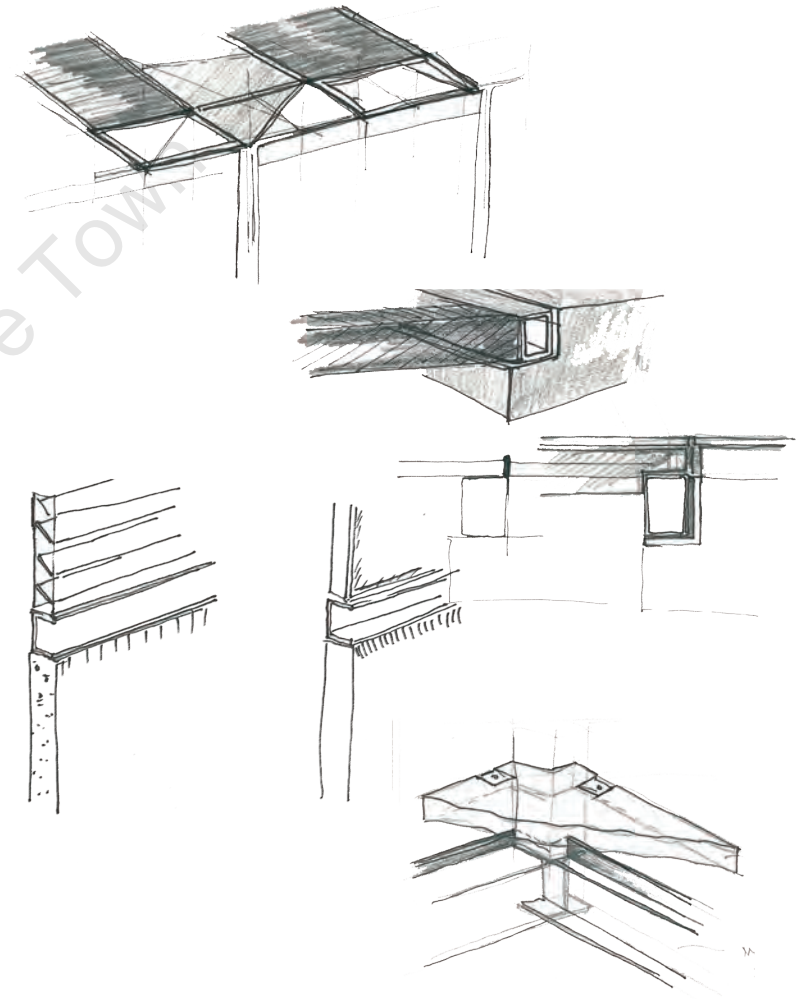


Figure 44 Technical studies in sketches



8.0 Conclusion

The Oasis of the Urban Nomad, designed for the public rather than as a public space in the strict sense, is ultimately a common ground that allows the unfolding of the public's [nomad's] social interaction, where meetings may be planned or happen haphazardly. The programming of the site, through third spaces, allows for a criss-crossing of people from different backgrounds whether it is in the café, in the resource centre, on the bridge of publicness or along the route to the different public transport modes. Although the bridge of publicness had a major influence in the spatial configuration of the overall scheme, its underlying determinant was the concept of publicness. Subsequently the programming and the built may be seen as one. They were both instrumental in the creation of The Oasis of the Urban Nomad which breeds publicness.

The Oasis of the Urban Nomad changes the conventional notion of a transport hub which becomes an integral part of the daily journey of the commuter, the pedestrian, the inhabitants of Mowbray and the man on the street. The overall scheme also helps to stitch the crack caused by the railway line. The bridge of Publicness is the physical manifestation that allows a better fusion of the fragmented parts of Mowbray by offering a seamless link to pedestrians and riders.

Further The Oasis of the Urban Nomad may be seen as a primer for future development as opposed to a finished product. It represents the armature to which further development may latch on and a subsequent flourishing in the publicness of the MPTI over time.

University of Cape Town

9.0 Glossary

Banerjee, T., 2001. The Future of Public Space: Beyond Invented Streets and Reinvented Places. *Journal of the American Planning Association* 67, 9–24.

Basulto, D., 2010. ArchDaily - US Embassy in London / KieranTimberlake Architects [WWW Document]. ArchDaily. URL <http://www.archdaily.com/50922/us-embassy-in-london-kieran-timberlake/> (accessed 6.25.13).

Blow, C.J., 2005. Transport terminals and modal interchanges: planning and design. Elsevier, Oxford.

Bordas, D.B., 2010. Open-Air-Library Magdeburg [WWW Document]. Public Space. URL <http://www.publicspace.org/en/works/f084-open-air-library/prize:2010>

Carr, S., 1992. Public Space. Cambridge University Press.

City Of Cape Town, 2009. Integrated Transport Plan for the City of Cape Town 2006 To 2011.

Cobix Technologies AG, 2004. Cobix [WWW Document]. Cobix-for Slim Slabs and Large Spans. URL <http://www.cobix.com/en/benefits.html> (accessed 10.14.13).

Cobix Technologies AG, 2010. Engineering Manual.

Day 7 - Community discussion on HIV/Aids [WWW Document], n.d. --- UN Millennium Development Goals --- Challenge for Today's Youth. URL <http://cstsouthafrica.wordpress.com/2010/09/17/day-6-community-discussion-on-hiv-aids/> (accessed 7.8.13).

Edwards, B., 2011. TRANSPORT INTERCHANGES: A CHALLENGE FOR URBAN DESIGN. *Urban Design* 120, 19–22.

Etherington, R., 2009. Open-air Library by KARO - Dezeen [WWW Document]. Dezeen. URL <http://www.dezeen.com/2009/10/28/open-air-library-by-karo/> (accessed 6.21.13).

Hajer, M.A., Reijndorp, A., 2001. In search of new public domain: analysis and strategy. NAI Publishers.

Hernandez, F., 2010. Bhabha for Architects. Routledge.

Hipwell, D., 2012. US embassy move is "investment magnet". *The Times* (London).

Krause, M., 2011. Violence Prevention through Urban Upgrading. *Digest Of South African Architecture* 16, 98–103.

Lawrence, A.R., Schafer, A., 2006. Re:programming. Praxis, Columbus, OH.

Oldenburg, R., 1999. The great good place: cafés, coffee shops, bookstores, bars, hair salons, and other hangouts at the heart of a community. Marlowe.

Oldenburg, R., 2009. Celebrating the Third Place: Inspiring Stories about the Great Good Places at the Heart of Our Communities. Da Capo Press.

Open Air Library / KARO Architekten [WWW Document], 2009. . ArchDaily. URL <http://www.archdaily.com/39417/open-air-library-karo-architekten/> (accessed 6.21.13).

Open-Air-Library Magdeburg [WWW Document], 2009. URL <http://www.architonic.com/aisht/open-air-library-magdeburg-karo/5100461> (accessed 6.21.13).

Ouroussoff, N., 2010. A New Fort, er, Embassy, for London. *The New York Times*.

Scramble starts for student accommodation at universities [WWW Document], n.d. Business Day Live. URL <http://www.bdlive.co.za/national/education/2013/01/18/scramble-starts-for-student-accommodation-at-universities> (accessed 9.4.13).

Susan, 2008. Traveling with an architect: california [WWW Document]. Transient Travels. URL <http://transienttravels.com/2008/09/22/traveling-with-an-architect-california/> (accessed 10.14.13).

Taylor, J., 2011. NEW RAILWAY STATIONS AS CATALYSTS FOR REGENERATION AND URBAN HUB. *Urban Design* 120, 29–31.

Tschumi, B., 1996. Architecture and Disjunction. MIT Press.

Van Der Merwe, D., 2011. Architectural Concrete. Cement And Concrete Institute, South Africa.

Varna, G., Tiesdell, S., 2010. Assessing the Publicness of Public Space:The Star Model of Publicness. *Journal of Urban Design* 15, 575–598.

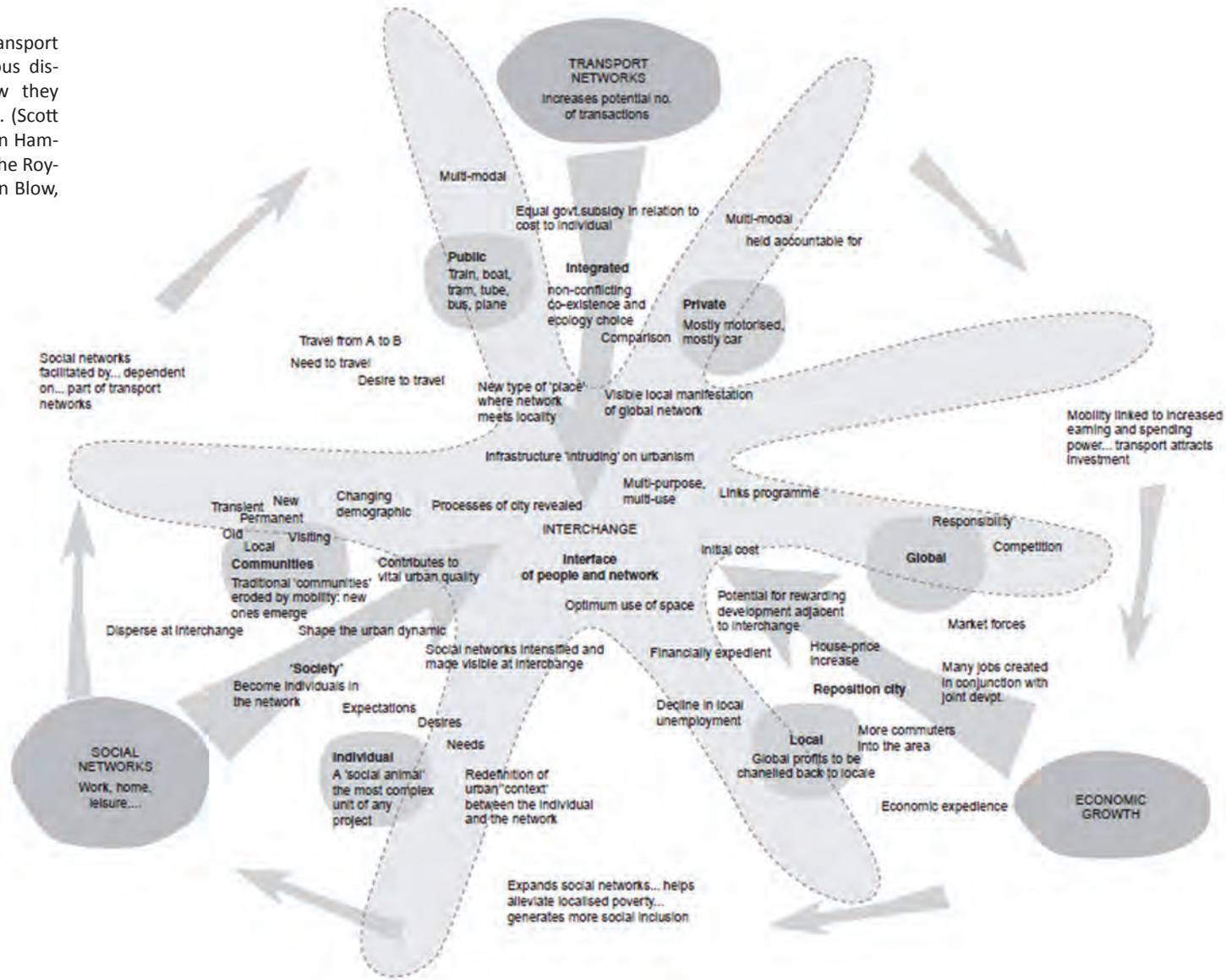
Verster, B., 2003. Multi-modal public transport interchanges (MMPTIs) as contributors to a positive urban living environment. Document Transformation Technologies Postal.

VPUU, n.d. Violence Prevention through Urban Upgrading [WWW Document].

What is VPUU? Designing for safety in spaces #WDC2014 [WWW Document], n.d. Future Cape Town. URL <http://futurecapetown.com/2011/07/what-is-vpuu-designing-for-safety-in-spaces-wdc2014/> (accessed 6.20.13).

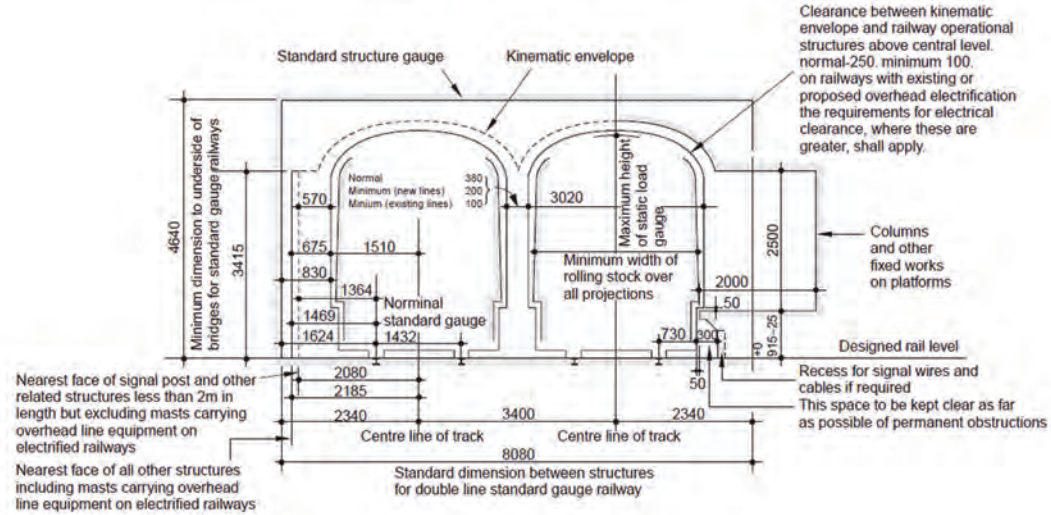
Appendix A:

The relationship of transport interchanges with various distinct spheres and how they influence these spheres. (Scott Brownrigg and the Helen Hamlyn Research Centre at the Royal College of Art (cited in Blow, 2005, p. 21)

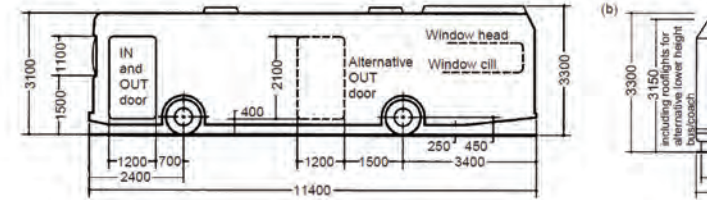


Appendix A: National Department of Transport Guidelines

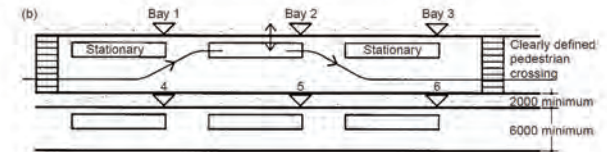
Cross-section: controlling dimensions for railway structures (British Standard)



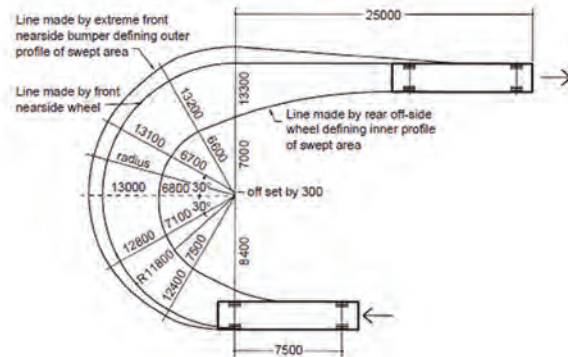
12m-bus dimensions



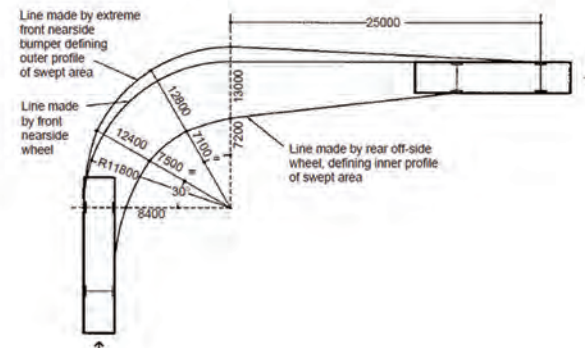
12m-bus drive through bay technical data (multiple)



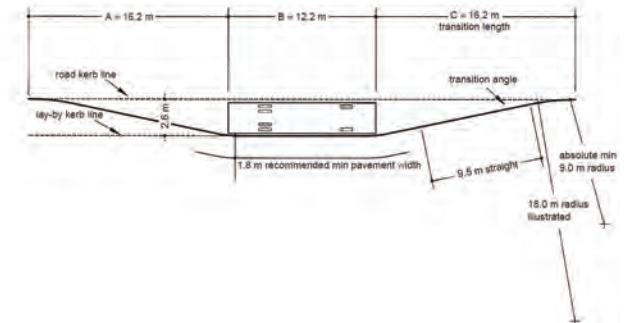
12m-bus turning angle (180°)



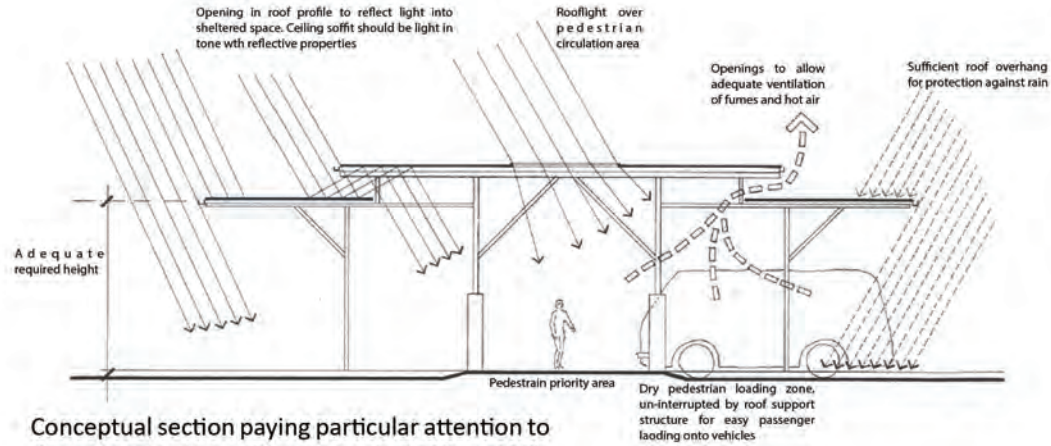
12m-bus turning angle (90°)



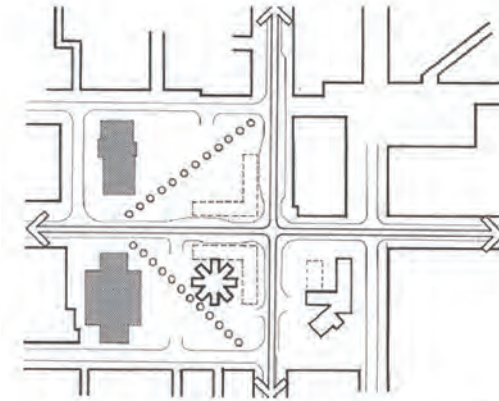
12m-bus drive through bay technical data (single)



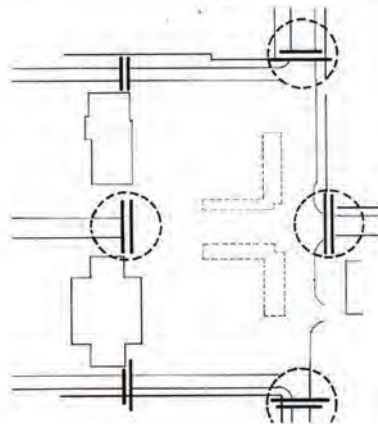
Appendix A: National Department of Transport Guidelines



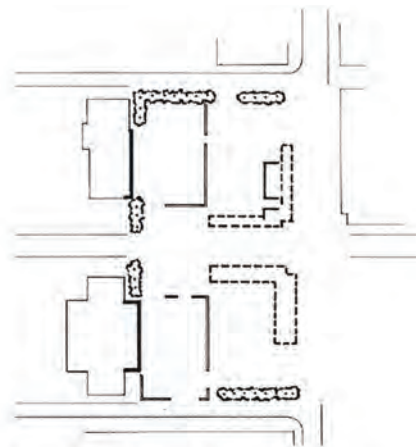
Conceptual section paying particular attention to the user experience (Naude et al., 2005, p. 337)



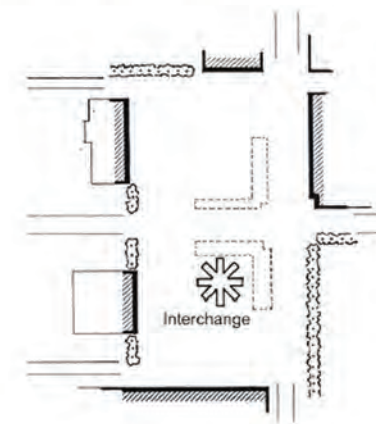
PTI Location and relation to its surrounding. (Naude et al., 2005, p. 338)



Accentuating point of arrivals (Naude et al., 2005, p. 337)



Space defining elements (Naude et al., 2005, p. 337)

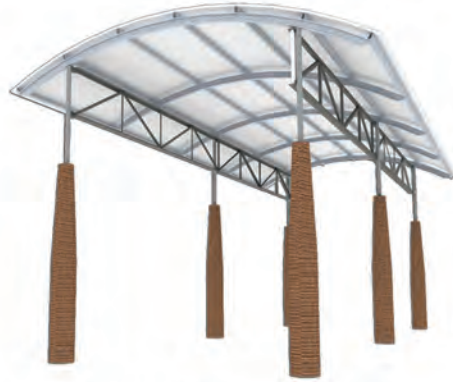


Clear boundary definition (Naude et al., 2005, p. 337)

APPENDIX B:
EXISTING STRUCTURES ON SITE



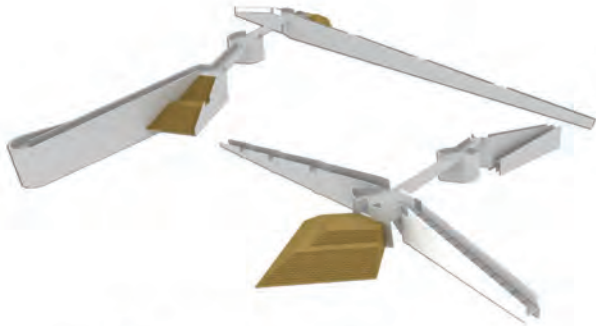
Bus Shelter



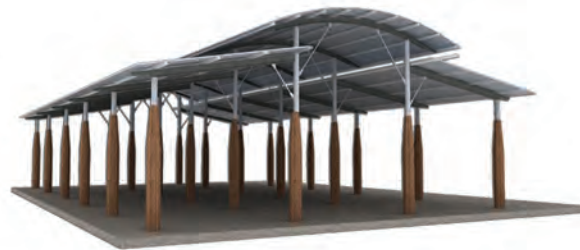
Pedestrian Walkway



Canopy at bridge entrances



Ramps and stairs

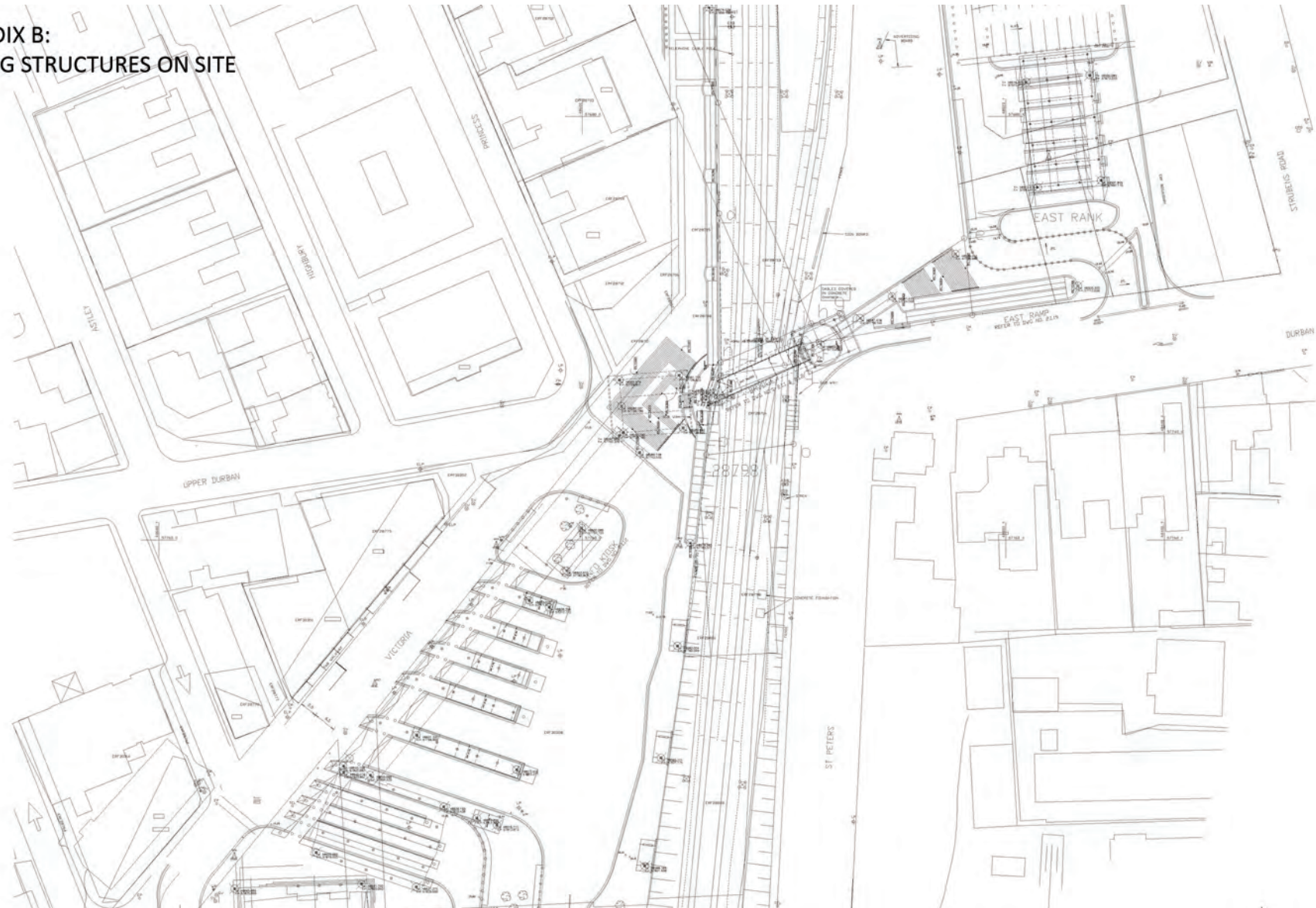


East Taxi Rank

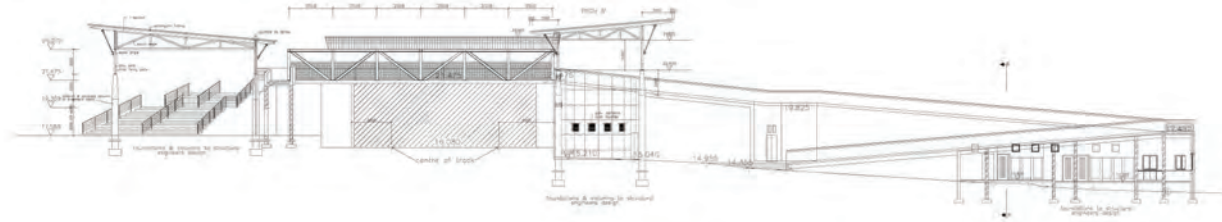


Pedestrian Bridge

**APPENDIX B:
EXISTING STRUCTURES ON SITE**

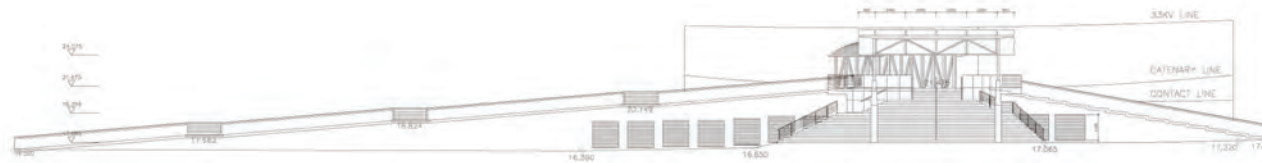
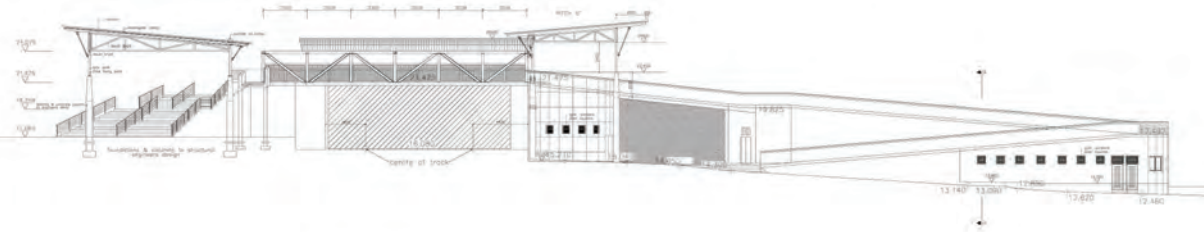


**APPENDIX B:
EXISTING STRUCTURES ON SITE**

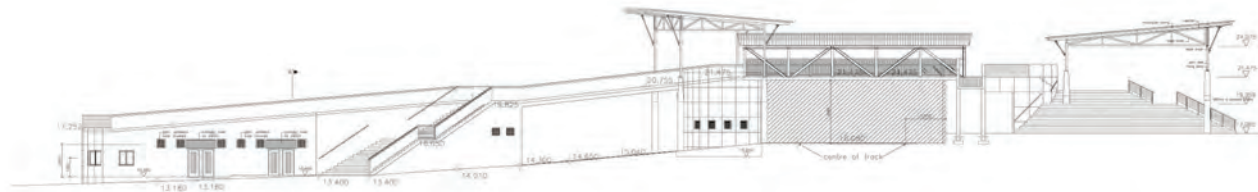
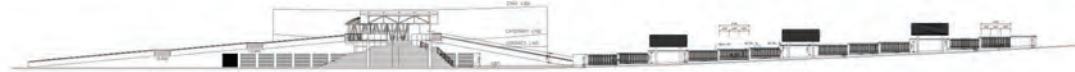


Section 1:1000

Durban Road Elevation 1:1000



West Rank Elevation 1:1000



East Rank Elevation 1:1000

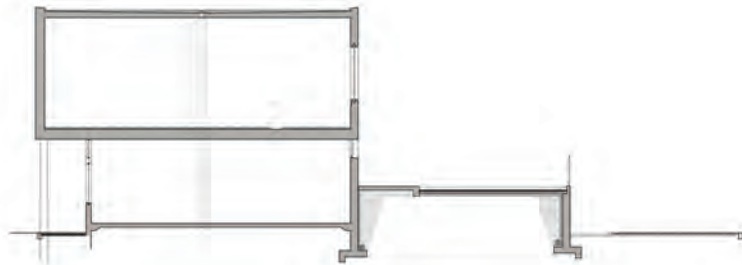
DRAWINGS

University of Cape Town

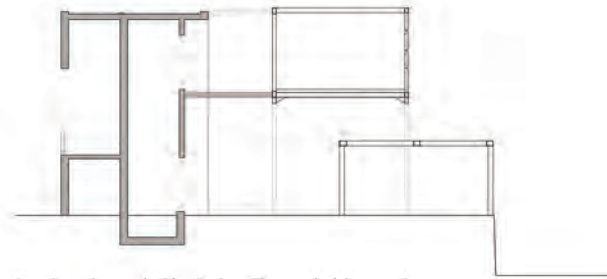
DRAWINGS :
SECTIONS
1:200



Section through Resource corner and Fitness Centre

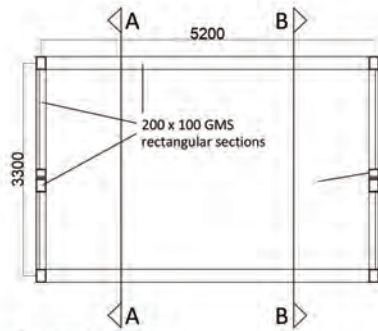
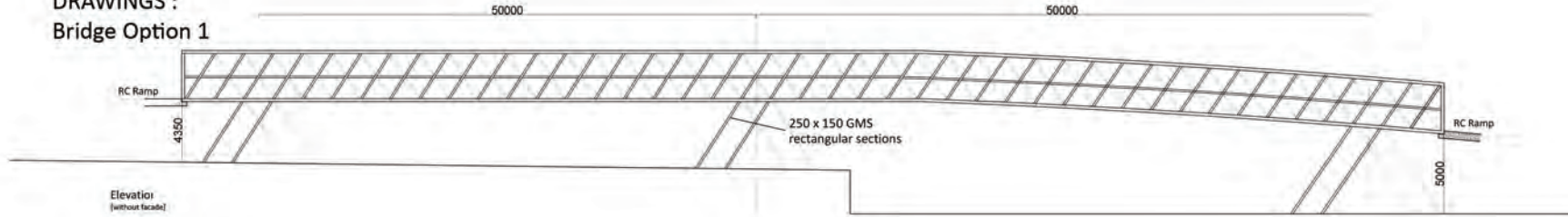


Section through Resource corner and Fitness Centre and ramp

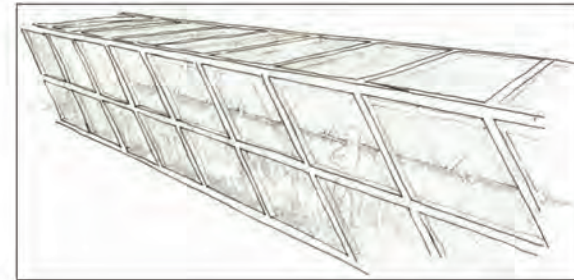
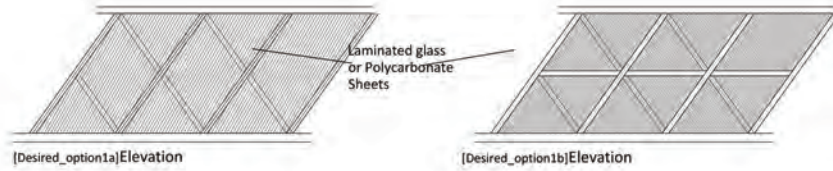
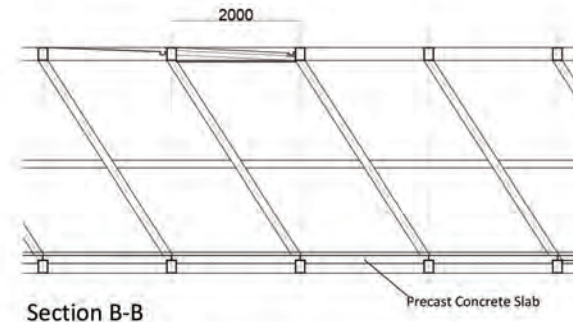
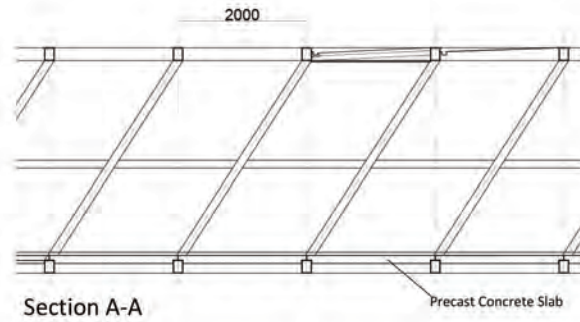


Section through Circulation Tower, bridge and ramp

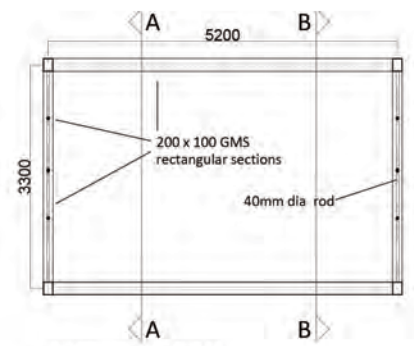
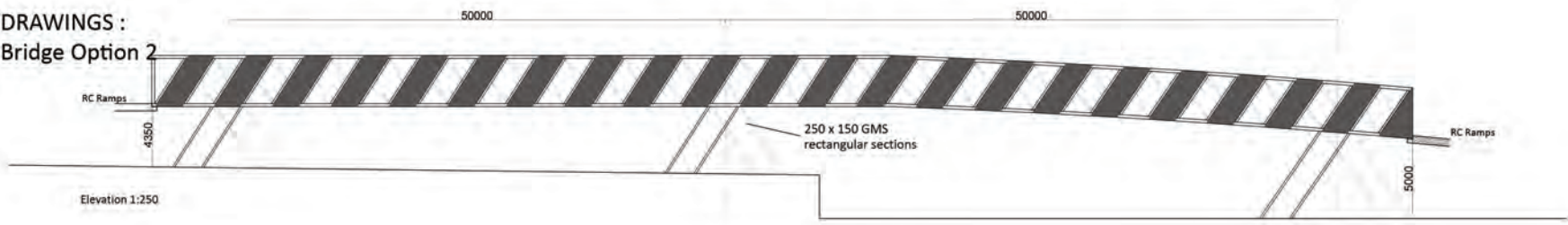
**DRAWINGS :
Bridge Option 1**



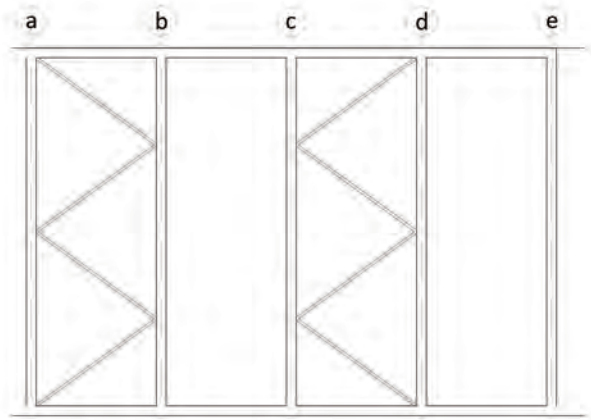
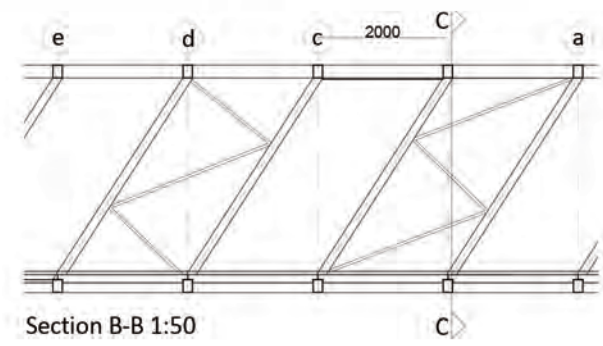
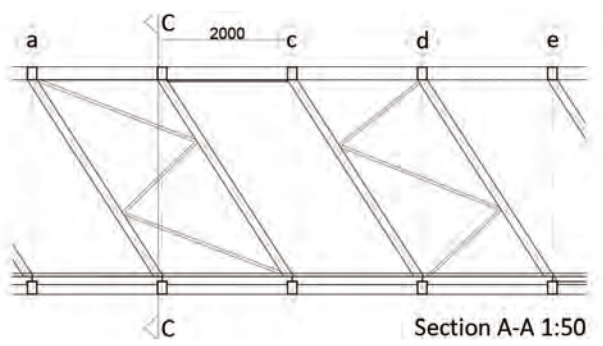
Typical Section



DRAWINGS :
Bridge Option 2



Section C-C 1:50



Roof 1:50

